



US 20060293575A1

(19) **United States**

(12) **Patent Application Publication**  
**Norris**

(10) **Pub. No.: US 2006/0293575 A1**

(43) **Pub. Date: Dec. 28, 2006**

(54) **SYSTEM FOR PREFILTERING A PLETHYSMOGRAPHIC SIGNAL**

**Publication Classification**

(76) Inventor: **Mark A. Norris**, Louisville, CO (US)

(51) **Int. Cl.**  
*A61B 5/00* (2006.01)

(52) **U.S. Cl.** ..... **600/336**

Correspondence Address:  
**MARSH, FISCHMANN & BREYFOGLE LLP**  
**3151 SOUTH VAUGHN WAY**  
**SUITE 411**  
**AURORA, CO 80014 (US)**

(57) **ABSTRACT**

A detector signal in a pulse oximeter is prefiltered, prior to processing so as to determine a physiological parameter value, so as to reduce the effects of artifact in the signal. An exemplary prefilter multiplies signal amplitude values by a quantity that is inversely proportional to a substantially current amplitude so as to reduce the amplitude of large amplitude sections typically associated with artifact. In one implementation, the quantity is a ratio of an amplitude associated with a clean section of the signal by some exponential factor of a substantially current amplitude. In this manner, artifact affected portions of the signal are deemphasized in subsequent analyses.

(21) Appl. No.: **11/250,201**

(22) Filed: **Oct. 14, 2005**

**Related U.S. Application Data**

(60) Provisional application No. 60/694,767, filed on Jun. 28, 2005.

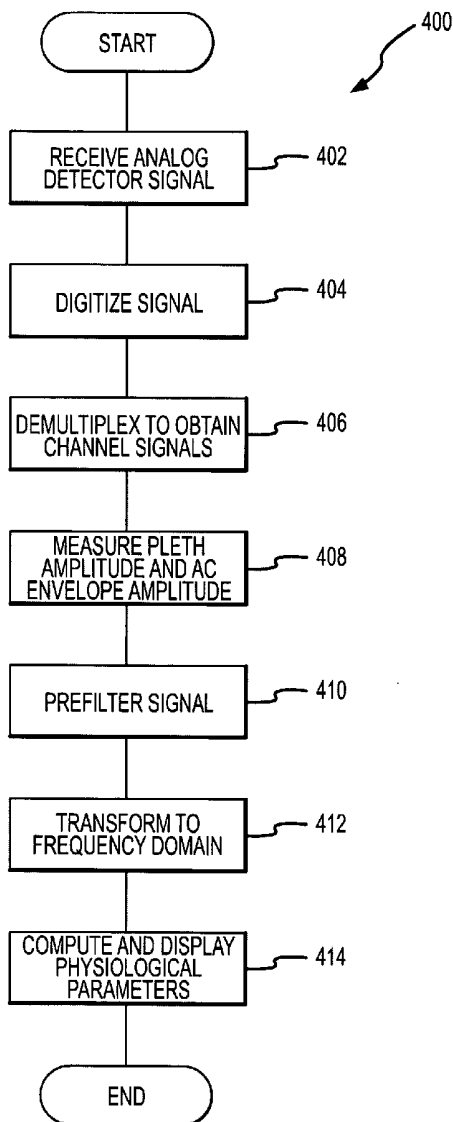

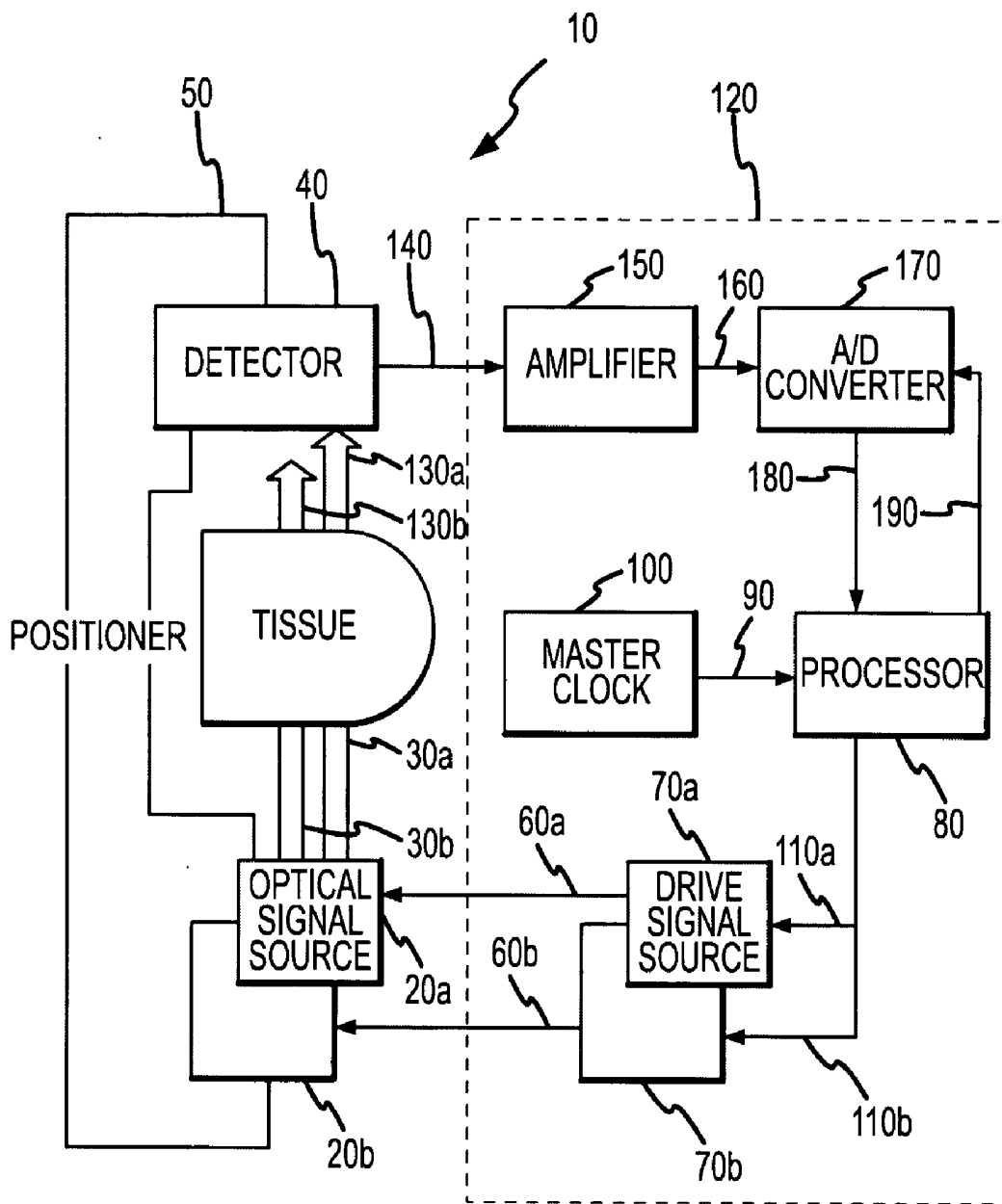
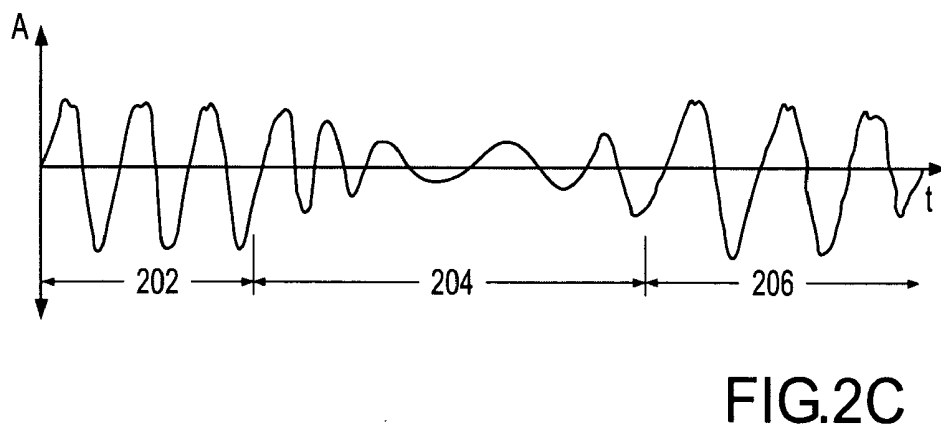
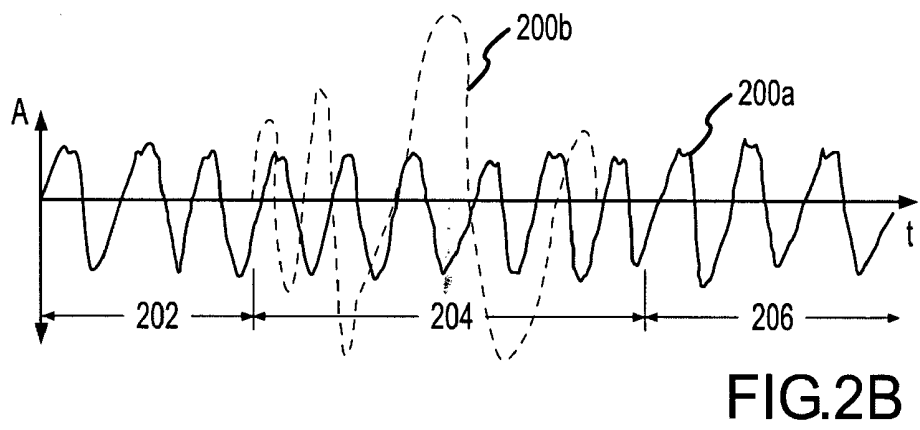
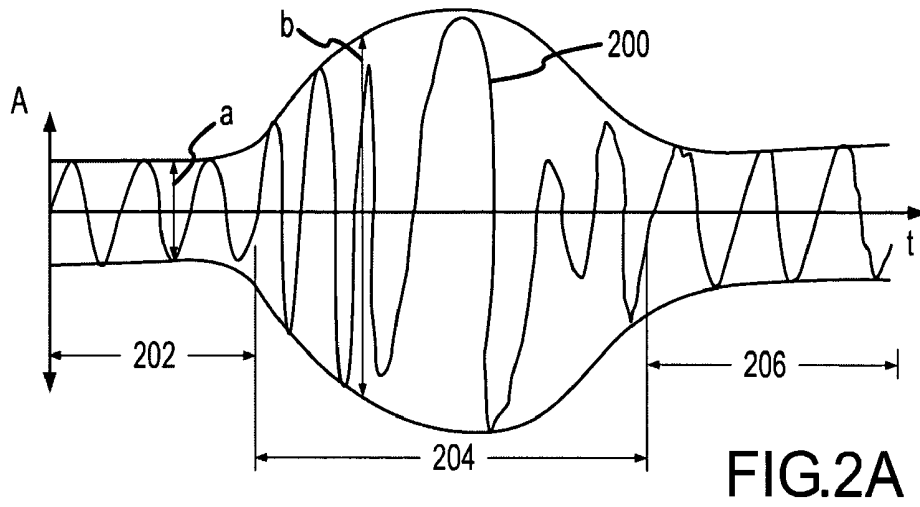

FIG.1



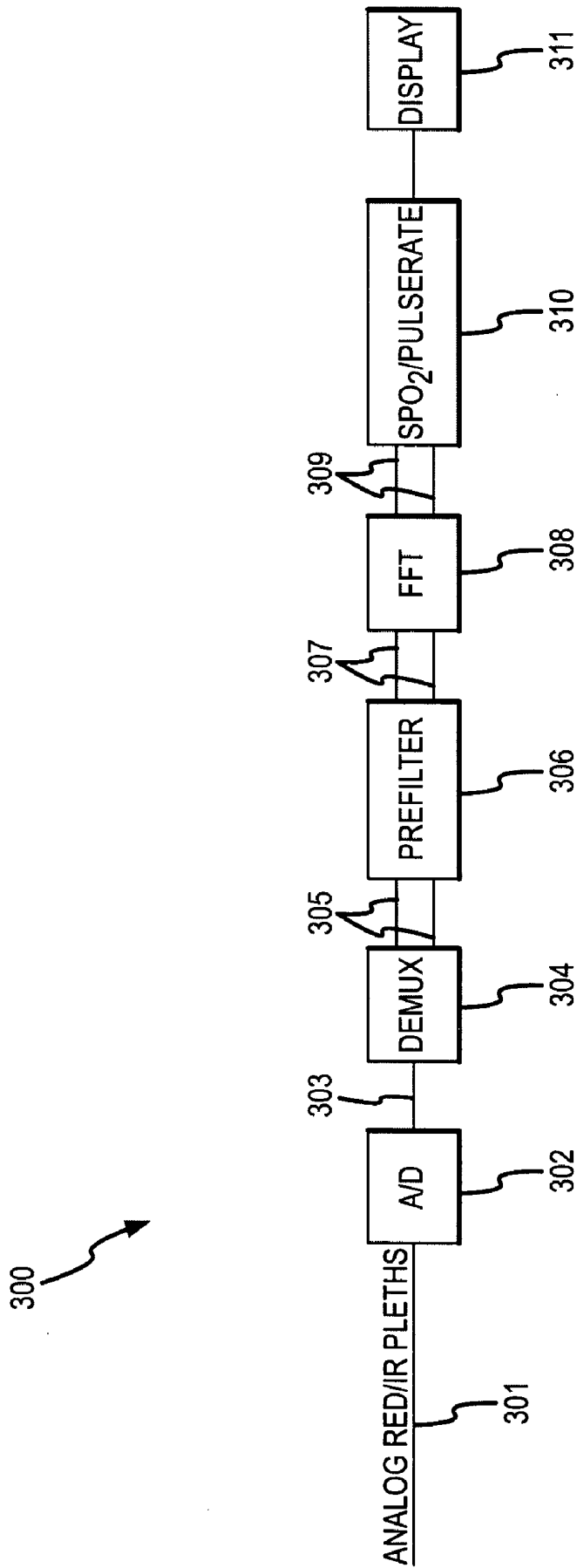

FIG.3

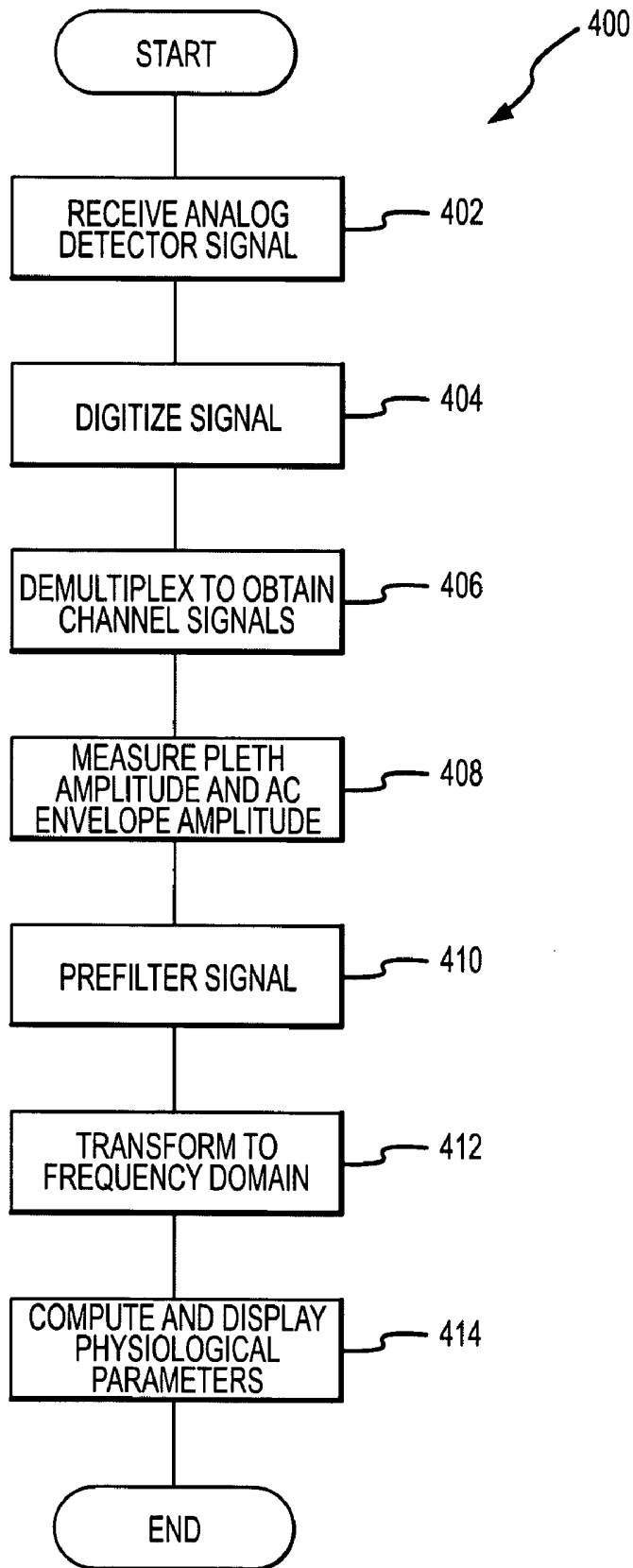

FIG.4

## SYSTEM FOR PREFILTERING A PLETHYSMOGRAPHIC SIGNAL

### CROSS REFERENCE TO RELATED APPLICATIONS

[0001] This application claims priority from U.S. Provisional Application Ser. No. 60/694,767 entitled "SYSTEM FOR PREFILTERING A PLETHYSMOGRAPHIC SIGNAL", filed on Jun. 28, 2005, the entirety of which is incorporated herein by reference.

### FIELD OF THE INVENTION

[0002] The present invention relates generally to photoplethysmography and, in particular, to pre-filtering a photoplethysmographic signal so as to reduce the effects of artifact in the signal.

### BACKGROUND OF THE INVENTION

[0003] Pulse oximeters determine an oxygen saturation level of a patient's blood, or related analyte values, based on transmission/absorption characteristics of light transmitted through or reflected from a patient's tissue. In particular, pulse oximeters generally include a probe for attaching to a patient's appendage such as a finger, earlobe or nasal septum, or another location, particularly in the case of reflective oximeters. The probe is used to transmit pulsed optical signals of at least two wavelengths, typically red and infrared, to the patient's tissue. The transmitted signals are received by a detector that provides an analog electrical output signal representative of the received optical signals. By processing the electrical signal and analyzing signal values for each of the wavelengths at different portions of the patient's pulse cycle, information can be obtained regarding blood oxygen saturation and/or other parameter values such as pulse rate, or blood pressure/blood volume related values.

[0004] The algorithms for determining blood oxygen saturation related values are normally implemented in a digital processing unit. Accordingly, one or more analog-to-digital (A/D) converters are generally interposed between the detector and the digital processing unit. Additionally, the detector signal is generally demodulated and demultiplexed by signal processing components. Demodulation involves separating the physiological signal of interest (generally including a more rapidly changing AC portion including a plethysmographic waveform and an optically based "DC" offset due to slowly changing absorption values associated with non-pulsatile tissue absorption) from a carrier waveform associated with the flashing optical sources. Demultiplexing involves separating the different wavelength components associated with the different signal sources. That is, because blood oxygen saturation is calculated based on differential absorption values for different transmitted optical signal wavelengths, the detected signal is generally separated, or demultiplexed, into at least two different wavelength components. Typically, demodulation and demultiplexing have been implemented in analog circuitry operatively disposed between the optical signal detector and the analog-to-digital converter(s), but can be digitally implemented.

[0005] A persistent problem in the field of pulse oximetry is eliminating or otherwise accounting for noise and other

artifact that can easily obscure or interfere with the pulsatile signals of interest. Some of the sources of this artifact include power line noise, electrical noise from other medical equipment, and artifact associated with patient motion. In this regard, certain filtering techniques have been employed both on the front end (i.e., in the analog circuitry between the optical signal detector and the analog-to-digital converter or converters) and in the back end (i.e., in the digital domain based on the signal from the analog-to-digital converter or converters) of the signal processing components.

[0006] Such front end filtering is generally used to filter the modulation signal as opposed to the physiological signal of interest. In this regard, the modulation signal may be approximately in the form of a square wave whereas the physiological signal of interest, which is carried by the modulation signal, may be in the form of a plethysmographic waveform. The front end filtering may include high pass and low pass filtering. For example, a low pass filter may be used to reject certain high frequency electronic noise and a high pass filter may be used to exclude certain low frequency phenomenon. Thus, such front end filtering is generally used to pass a broad frequency range including the modulation frequency or frequencies and is not directed to targeted elimination of interference with respect to the AC portion of the signal.

[0007] Back end filtering is sometimes used to filter noise from the physiological signal of interest. This often involves frequency dependent filtering such as bandpass filtering. Unfortunately, some sources of artifact can include frequency components within the physiological range of interest. For example, motion artifact may be observed within the physiological range of interest. With regard to motion, a number of different digital filtering or other compensation algorithms have been proposed or implemented with varying degrees of success. However, in some cases, these algorithms may either fail to satisfactorily address the effects of motion artifact or may filter out useful pulsatile information to an undesirable extent.

[0008] Other approaches to addressing artifact involve deemphasizing or excluding parameter calculations deemed to be based on data that is significantly affected by motion or other artifact. For example, presumed high artifact conditions have been identified based on an analysis of a spectrum of the detector signal to identify spectral characteristics indicative of artifact or the absence of spectral characteristics indicative of a well-defined pulsatile signal. In other cases, presumed high artifact conditions have been identified based on a result of calculations deemed unlikely to have a physiological basis, e.g., calculated values corresponding to an unlikely value of arterial oxygen saturation, an abrupt change thereof, or an unlikely variance from a trend in data related to oxygen saturation with respect to a time window under consideration.

[0009] Upon identification of such artifact conditions, associated calculated values may be ignored for purposes of determining a result or may be deweighted, for example, by increasing the size of a time window of data used for calculations (thereby presumably reducing the impact the motion affected data on the result) or by applying confidence or weighting factors to each of a series of calculated values used in obtaining a resulting value, so as to achieve a kind of weighted average wherein motion affected data is deem-

phasized. However, such approaches have had limited success in addressing a variety of motion conditions. Moreover, in some cases, such approaches have required difficult or questionable judgments in distinguishing different motion conditions, have required complicated processing and/or have limited the methodologies available for physiological parameter calculations.

#### SUMMARY OF THE INVENTION

**[0010]** The present invention relates to prefiltering a detector signal in a medical instrument, such as a pulse oximeter, so as to deemphasize artifact, such as motion artifact, in the signal prior to performing calculations to determine physiological information based on the signal. In this manner, the calculations can proceed, across a range of artifact conditions, without requiring selection between alternative calculations or the results thereof, without associated judgments as to characterization of the motion environment, and without variations or dynamic corrections to the algorithms. Moreover, short intervals of well-defined physiological signals can be effectively utilized to provide meaningful results. Such prefiltering also allows for effective implementation of a variety of calculation processes, including processes executed with respect to time or frequency domain data, over a range of artifact conditions. Such calculations can be implemented substantially free of additional processing for motion correction or compensation.

**[0011]** The present inventor has recognized, in the context of pulse oximetry, that motion is often episodic and has the transient effect of increasing the amplitude of the AC signal, often to the point that the signal of interest is practically obscured. That is, during motion episodes, the AC signal may be viewed as being composed of the superimposition of an artifact signal on the pulsatile signal, resulting in an integrated signal tending to have peaks of greater amplitude (e.g., associated with intervals of constructive interference between the components) than the peaks associated with intervals of substantially clean pulsatile signals having little or no artifact. In connection with certain signal processing techniques, e.g., certain spectral domain analyses, the noisy portions of the signal tend to be emphasized in relation to cleaner portions, which is typically undesirable. This effect is reversed, in accordance with the present invention, by implementing a prefiltering process to deemphasize signal portions believed to be affected by artifact prior to processing to obtain physiological information regarding a patient.

**[0012]** In accordance with one aspect of the present invention, a method and apparatus (collectively "utility") is provided for reducing the amplitude of a portion of a pulse oximeter signal deemed to be affected by artifact. Specifically, the utility involves receiving an electronic signal reflective of one or more optical signals incident on a detector of a pulse oximeter where the electronic signal includes a first temporal portion that is potentially corrupted by artifact. For example, the electronic signal may be an AC signal corresponding to one of the red and infrared channels of a pulse oximeter. The signal is processed such that an amplitude associated with the first temporal portion of the signal is reduced in relation to that of a second temporal portion of the signal. The resulting processed signal can then be used to obtain physiological information regarding the patient, such as a pulse rate or SpO<sub>2</sub> value. In one implementation, the noted processing is implemented by a pre-

filter which operates substantially continuously on the electronic signal such that it is unnecessary to explicitly identify the artifact affected portion of the signal. Alternatively, such a filter may operate intermittently based on identification of specified artifact conditions, such as signal portions exceeding an amplitude threshold or other threshold believed to be related to artifact. The noted utility thus provides a prefiltered signal where the effects of artifact are reduced. This signal can be processed in conventional fashion to obtain the desired physiological information with reduced impact due to artifact.

**[0013]** In accordance with another aspect of the present invention, a utility is provided for identifying an artifact condition based on the amplitude of an oximeter signal. The utility involves receiving an electronic signal reflective of one or more optical signals incident on a detector of a pulse oximeter and identifying, based on an amplitude related analysis of the received signal, an artifact affected portion of the signal. In this regard, an artifact condition may be identified based on an increased amplitude of an AC portion of the signal. For example, the artifact condition may be identified based on an amplitude exceeding a predetermined threshold, a change in the amplitude over a time period exceeding a predetermined threshold or another amplitude-related analysis. Upon identification of the artifact condition, a correction is applied to reduce an effect of the artifact. In this regard, various processes have been developed for reducing the effect of artifact including bandpass filtering around the pulsatile fundamental frequency, motion cancellation, and motion correction factors applied to physiological parameter calculation. Any such correction or combinations thereof may be applied in accordance with the present invention. Alternatively, the noted identification and correction may be implemented by a prefilter, as described above, that operates to reduce the amplitude of the artifact affected portion of the signal.

**[0014]** Any process that has the effect of reducing an amplitude of the artifact affected portion of the signal in relation to a clean portion of the signal may be used in this regard. For example, only the amplitude of the clean portion of the signal may be increased, only the amplitude of the artifact affected portion of the signal may be reduced, or the amplitude of the clean portion may be increased while that of the artifact affected portion is reduced. Alternatively, the amplitude of the artifact affected portion may be increased by a lesser factor than that of the clean portion or the amplitude of the artifact affected portion may be reduced by a greater factor than that of the clean portion. The amplitude of the artifact affected portion may be processed to achieve the effect of multiplying the amplitude by a factor of less than 1.0 (e.g., multiplying by a value less than 1.0 or dividing by a value greater than 1.0). In this regard, an amplitude value of the artifact affected portion may be processed to achieve the effect multiplying the amplitude value by a factor that is inversely proportional to an amplitude related value of the artifact affected signal portion or a multiple or exponential value thereof. As a further alternative, the clean and artifact affected portions of the signal may be processed to achieve the effect of multiplying by a quantity including a ratio of some multiple or exponential factor of a reference amplitude (e.g., associated with a clean signal portion) by some multiple or exponential factor of a substantially current amplitude.

[0015] In accordance with a still further aspect of the present invention, a utility is provided for prefiltering an oximeter signal prior to spectral processing. The utility involves receiving a time-based signal reflective of one or more optical signals incident on a detector of a pulse oximeter and performing a correction with respect to a portion of the received time-based signal to reduce an effect of artifact. For example, the signal may be prefiltered as discussed above to reduce the amplitude of an artifact affected portion of the signal in relation to relatively clean signal portions. A transform is then performed on the processed time-based signal to obtain transformed information relative to a second domain. In this regard, the processed, e.g., prefiltered, signal may be subjected to a Fourier transform such as an FFT to yield a frequency domain signal. The transformed information may include the frequency domain signal or parameters thereof, such as peak frequency and amplitude values. The transformed information is then processed to obtain physiological information regarding a patient. For example, in the case of frequency domain processing, a fundamental frequency may correspond to pulse rate or a ratio of amplitudes of the fundamental or other peaks of the red and infrared channel signals may be used to obtain an indication of SpO<sub>2</sub>. It will be appreciated that prefiltering in this regard may assist in identification of the desired spectral peaks relating to pulsatile phenomena, thereby enhancing such conventional spectral domain processing.

#### BRIEF DESCRIPTION OF THE DRAWINGS

[0016] For a more complete understanding of the present invention and further advantages thereof, reference is now made to the following detailed description taken in conjunction with the drawings, in which:

[0017] **FIG. 1** is a block diagram of a pulse oximeter in accordance with the present invention;

[0018] **FIGS. 2A-2C** illustrate a prefiltering process in accordance with the present invention;

[0019] **FIG. 3** is a schematic diagram illustrating a system implementing a prefilter in accordance with the present invention; and

[0020] **FIG. 4** is a flow chart illustrating a method for processing a detector signal including prefiltering in accordance with the present invention.

#### DETAILED DESCRIPTION

[0021] Referring now to **FIG. 1**, there is shown a block diagram of one embodiment of a pulse oximeter **10** in which a prefilter in accordance with the present invention may be implemented. The pulse oximeter **10** is configured for use in determining the pulse rate of a patient as well as one or more blood analyte levels in the patient, such as an SpO<sub>2</sub> level. It should be appreciated that a prefilter in accordance with the present invention may be implemented in pulse oximeters that are configured differently from the pulse oximeter depicted in **FIG. 1** as well as in other environments wherein plethysmographic signals are processed in order to obtain desired information relating to patient physiological conditions from the plethysmographic signals.

[0022] The illustrated pulse oximeter **10** includes a pair of optical signal sources **20a, 20b** for emitting a corresponding

pair of light signals **30a, 30b** centered at different predetermined center wavelengths  $\lambda_1, \lambda_2$  through a suitable tissue site of a patient and on to a detector **40** (e.g., a photo-sensitive diode). It will be appreciated that the signals may be reflected from the tissue rather than transmitted through the tissue in accordance with the present invention.

[0023] The optical signal sources **20a, 20b** and detector **40** may be included in a positioning device **50**, or probe structure, to facilitate alignment of the light signals **30a, 30b** with the detector **40**. For example, the positioning device **50** may be of clip-type or flexible strip configuration adapted for selective attachment to a suitable patient tissue site (e.g., a finger, an ear lobe, a foot, or the nose of the patient). The center wavelengths  $\lambda_1, \lambda_2$  required depend upon the blood analyte level to be determined. For example, in order to determine an SpO<sub>2</sub> level,  $\lambda_1$  may be in the red wavelength range and  $\lambda_2$  may be in the infrared wavelength range. It should be appreciated that the pulse oximeter **10** may be readily implemented with more optical signal sources (e.g., four) depending, for example, upon the number of different blood analyte levels to be measured.

[0024] The optical signal sources **20a, 20b** are activated by a corresponding plurality of drive signals **60a, 60b** to emit the light signals **30a, 30b**. The drive signals **60a, 60b** are supplied to the optical signal sources **20a, 20b** by a corresponding plurality of drive signal sources **70a, 70b**. The drive signal sources **70a, 70b** may be connected with a digital processor **80**, which is driven with a clock signal **90** from a master clock **100**. The digital processor **80** may be programmed to define modulation waveforms, or drive patterns, for each of the optical signal sources **20a, 20b**. More particularly, the digital processor **80** may provide separate digital trigger signals **110a, 110b** to the drive signal sources **70a-b**, which in turn generate the drive signals **60a, 60b**. In this regard, the digital trigger signals **110a, 110b** may be configured to provide for multiplexing of the drive signals **60a, 60b**, and in turn the light signals **30a, 30b**, in accordance with a multiplexing scheme (e.g., time division, frequency division, and/or code division multiplexing).

[0025] The drive signal sources **70a, 70b**, processor **80** and clock **100** may all be housed in a monitor unit **120**. While the illustrated embodiment shows the optical signal sources **20a, 20b** physically interconnected with the positioning device **50** (e.g., mounted within the positioning device **50** or mounted within a connector end of a cable that is selectively connectable with the positioning device **50**), it should be appreciated that the optical signal sources **20a, 20b** may also be disposed within the monitor unit **120**. In the latter case, the light signals **30a, 30b** emitted from the optical signal sources **20a, 20b** may be directed from the monitor unit **120** via one or more optical fibers to the positioning device **50** for transmission through the tissue site. Furthermore, the drive signal sources **70a, 70b** may comprise a single drive signal generator unit that supplies each of the drive signals **60a, 60b** to the optical signal sources **20a, 20b**.

[0026] Transmitted light signals **130a, 130b** (i.e., the portions of light signals **30a, 30b** exiting the tissue) are detected by the detector **40**. The detector **40** detects the intensities of the transmitted signals **130a, 130b** and outputs a current signal **140** wherein the current level is indicative of the intensities of the transmitted signals **130a, 130b**. As may be appreciated, the current signal **140** output by the detector **40**

comprises a multiplexed signal in the sense that it is a composite signal including information about the intensity of each of the transmitted signals **130a**, **130b**. Depending upon the nature of the drive signals **60a**, **60b**, the current signal **140** may, for example, be time division multiplexed, wavelength division multiplexed, and/or code division multiplexed.

[0027] The current signal **140** is directed to an amplifier **150**, which may be housed in the monitor unit **120** as is shown. As an alternative, the amplifier **150** may instead be included in a probe/cable unit that is selectively connectable with the monitor unit **120**. The amplifier **150** converts the current signal **140** to a voltage signal **160** wherein a voltage level is indicative of the intensities of the transmitted signals **130a**, **130b**. The amplifier **150** may also be configured to filter the current signal **140** from the detector **40** to reduce noise and aliasing. By way of example, the amplifier **150** may include a bandpass filter to attenuate signal components outside of a predetermined frequency range encompassing modulation frequencies of the drive signals **60a**, **60b**.

[0028] Since the current signal **140** output by the detector **40** is a multiplexed signal, the voltage signal **160** is also a multiplexed signal, and thus, the voltage signal **160** is demultiplexed in order to obtain signal portions corresponding with the intensities of the transmitted light signals **130a**, **130b**. In this regard, the digital processor **80** may be provided with demodulation software for demultiplexing the voltage signal **160**. In order for the digital processor **80** to demodulate the voltage signal **160**, it is converted from analog to digital. Conversion of the analog voltage signal **160** is accomplished with an analog-to-digital (A/D) converter **170**, which may also be included in the monitor unit **120**. The A/D converter **170** receives the analog voltage signal **160** from the amplifier **150**, samples the voltage signal **160**, and converts the samples into a series of digital words **180** (e.g., eight, sixteen or thirty-two bit words), wherein each digital word is representative of the level of the voltage signal **160** (and hence the intensities of the transmitted light signals **130a**, **130b**) at a particular sample instance. In this regard, the A/D converter **170** preferably provides for sampling of the voltage signal **160** at a rate sufficient to provide for accurate tracking of the shape of the various signal portions comprising the analog voltage signal **160** being converted. For example, the A/D converter **170** may provide for a sampling frequency at least twice the frequency of the highest frequency drive signal **60a**, **60b**, and more preferably at an even greater sampling rate in order to more accurately represent the analog voltage signal.

[0029] The series of digital words **180** is provided by the A/D converter **170** to the processor **80** to be demultiplexed. More particularly, the processor **80** may periodically send an interrupt signal **190** (e.g., once per every eight, sixteen or thirty-two clock cycles) to the A/D converter **170** that causes the A/D converter **170** to transmit one digital word **180** to the processor **80**. The demodulation software may then demultiplex the series of digital words **180** in accordance with an appropriate method (e.g., time, frequency and/or code) to obtain digital signal portions indicative of the intensities of each of the transmitted light signals **130a**, **130b**. In this regard, the demultiplexed digital signal portions comprise time domain plethysmographic signals corresponding to the center wavelengths  $\lambda_1$ ,  $\lambda_2$  (e.g., red and infrared) of the optical signal sources **20a**, **20b**. The red and infrared time

domain plethysmographic signals may then be processed by the processor **80** to obtain desired patient physiological condition related information therefrom such as the patient's pulse rate and SpO<sub>2</sub> level.

[0030] In accordance with the present invention, a pulse oximeter as described above includes a prefilter for prefiltering the detector signal to reduce the effects of artifact in the signal. As noted above, the detector signal generally includes a physiological signal carried by a modulation waveform which generally implements a multiplexing scheme. The physiological signal generally includes a larger, more slowly varying portion commonly referred to as the DC portion, and a smaller, higher frequency portion generally referred to as the AC portion. The AC portion includes the pulsatile signal which is generally of interest for determining pulse rate, SpO<sub>2</sub> and the like. However, it has been observed that in periods of high artifact such as certain motion episodes that this AC component can become significantly distorted. This distortion is characterized by a substantial increase in AC amplitude.

[0031] This is generally shown in FIG. 2A. FIG. 2A illustrates an exemplary time interval of an AC signal **200**. The illustrated time interval includes an initial relatively clean time period generally indicated at **202** followed by a high artifact interval **204** and concludes with another interval **206** characterized by a relatively clean signal. That is, in intervals **202** and **206**, the AC signal **200** is characterized by a relatively well-defined plethysmographic waveform ("pleth"). By contrast, during interval **204**, the pleth is substantially distorted by artifact.

[0032] FIG. 2B illustrates a theoretical decomposition of the pulsatile signal **200** into a pulsatile component **200a** and an artifact signal **200b** during the time interval **204**. As shown, it is generally theoretically expected that the pulsatile signal is present during periods of motion. However, the signal is affected by interference by the superimposed artifact signal **200b**. One effect of this superposition of signal components **200a** and **200b** is that the signal **200a** is substantially obscured. Another effect is that the combination of these signals results in an increased amplitude of the composite signal **200** during time interval **204** as shown in FIG. 2A. Unfortunately, when a Fourier transform is performed extending across the integrated time period **202**, **204** and **206**, the high amplitude portion of the integrated time period, that is, time interval **204**, may dominate the resulting spectrum. Consequently, the contributions due to time intervals **202** and **206** are largely overwhelmed.

[0033] It will be appreciated that these intervals **202** and **206** of well defined pulsatile signals include useful information which may provide an accurate indication of SpO<sub>2</sub>, pulse rate and other parameters. Moreover, in many cases, motion is episodic and transient. For example, in connection with monitoring neonates, short intervals of well defined pulsatile signals may be present within an otherwise noisy waveform. It would be desirable to isolate or emphasize these useful signal portions in relation to the surrounding artifact affected portions. However, as previously noted, conventional processing techniques often allow such useful signal portions to be overwhelmed by the artifact affected portions.

[0034] In one implementation of the present invention, the AC signal **200** is prefiltered so as to reduce the amplitude of

large amplitude signal portions in relation to smaller amplitude signal portions. Because the low amplitude signal portions are believed to generally correspond to clean, well defined pulsatile signals, whereas the larger amplitude portions are believed to correspond to artifact affected signals, such deemphasizing of the large amplitude portions results in a prefiltered signal where the clean signal portions are relatively emphasized. These prefiltered signals can then be processed using conventional techniques to obtain desired physiological information such as SpO<sub>2</sub> or pulse rate with reduced impact due to artifact.

[0035] The functionality of this prefilter may be understood by reference to FIG. 2A. Specifically, in one implementation, the prefilter utilizes two signal parameters, a and b, to execute a transfer function for generating the prefiltered signal. The parameter a is a measure of the amplitude of pulsatile signal. This value may be obtained in a variety of ways. For example, the value a may be determined by a peak to trough measurement of the AC signal 200 during a time interval deemed to represent a clean waveform, e.g., interval 202 or 206. Alternatively, the value a may be based on the amplitude of a pulsatile spectral peak after performing a transform on the AC signal 200. Many other techniques are available to obtain an indication of the parameter a. In this regard, it should be noted that pulse oximeters generally use a value corresponding to a in determining SpO<sub>2</sub>. Accordingly, such information may be readily available from calculations performed on preceding time intervals of the AC signal 200. Moreover, as will be understood from the description below, it is not essential that the value of a be determined accurately so long as it provides a reasonable reference value for use in the transfer function as described below.

[0036] The second parameter used by the prefilter, b, is a substantially instantaneous measure of the amplitude of the AC signal 200. As shown in FIG. 2A, this value may indicate the instantaneous width of an envelope described by the AC signal 200. Again, this value may be determined in various ways. For example, the value may be determined based on a peak to trough measurement of the time-based AC signal 200. Alternatively, a curve may be fitted to the local extrema of the AC signal 200 to define the upper and lower boundaries of the envelope 208. The instantaneous distance between these boundaries will then define the parameter b. It will be appreciated that many other techniques are possible to determine the parameter b in accordance with the present invention.

[0037] The prefilter in the illustrated embodiment then uses the parameters a and b to deemphasize larger amplitude portions of the AC signal 200. The result is to substantially invert the shape of the envelope 208. This can be simply accomplished by implementing the following transfer function.

$$f(n)=a/bx$$

[0038] where x is preferably greater than or equal to 1.

[0039] Thus, each value of the AC signal 200 is multiplied by the transfer function above to yield a resulting value of the prefiltered signal. In periods of substantially clean pulsatile signal, the value of a will be substantially equal to the value of b. In this case, if the value of a is normalized to be equal to 1.0, the amplitude of the pulsatile signal in the

prefiltered waveform will be equal to the amplitude in the unfiltered detector signal. Moreover, in this case, where the amplitude of the AC signal 200 increases relative to the reference value a, the corresponding amplitude of the prefiltered signal will be reduced. The degree of such reduction will depend on the value of x. Currently, it is believed that good results regarding reducing the effects of artifact can be achieved by setting x to be on the order of 2 to 3, but x need not be an integer value.

[0040] The resulting prefiltered signal is generally illustrated in FIG. 2C. As shown, the relatively clean sections 202 and 206 are substantially unaffected by application of the prefilter. By contrast, the artifact affected section 204, rather than having an increased amplitude as in FIG. 2A, now has a substantially reduced amplitude. As a result, various algorithms applied with respect to the integrated time period 202, 204 and 206 will have a reduced impact due to the artifact. For example, a Fourier transform executed with respect to the integrated time period 202, 204 and 206 will likely reflect larger peaks associated with the pulsatile signal and only smaller peaks corresponding to the artifact signal. This will substantially improve associated calculations to determine values such as pulse rate and SpO<sub>2</sub> even without any other modification of the conventional algorithms in this regard.

[0041] The prefilter can be implemented in hardware or software. In one implementation, the prefilter is implemented in the processor 80 of FIG. 1. Specifically, the processor receives the AC signal 200 after digitization, and demultiplexing of the detector signal. In addition, the carrier wave and DC portion may be removed from the detector signal. The values of a and b can then be determined as described above to define the prefilter transfer function. The transfer function may be implemented by setting appropriate filter coefficients.

[0042] An associated system 300 including the prefilter is illustrated in FIG. 3. The illustrated system 300 includes an analog to digital converter 302, as generally described above, that receives the analog red and infrared photoplethysmographic signals or pleths, from the detector via certain front end circuitry. The resulting digitized, multiplexed signal 303 is then processed by demultiplexer 304 to provide separate AC signals 305 corresponding to the separate channels of the pulse oximeter. Each of the signals 305 is processed by a prefilter 306 as described above to yield prefiltered signals 307. In the illustrated implementation, these signals 307 are processed by a fast Fourier transform module 308 to yield frequency spectra 309. These spectra 309 are then processed in conventional fashion by SpO<sub>2</sub> and pulse rate module 310 to provide pulse rate and oxygen saturation information that can be output to a display 311 of the pulse oximeter. For example, a fundamental peak of one of the spectra may be used to determine pulserate. The fundamental (and/or other) peaks of both spectra may be used to determine SpO<sub>2</sub>.

[0043] A corresponding process 400 can be summarized by reference to the flow chart of FIG. 4. The process 400 is initiated by receiving (402) the analog detector signal. The analog detector signal is then digitized (404) by an A/D converter such as a fast A to D converter as discussed above. The resulting signals are demultiplexed (406) to obtain channel signals corresponding to the red and infrared optical

signals of the pulse oximeter. The pleth amplitude and AC envelope amplitude are then measured (408) to provide the parameters used by the prefilter. The signal is then prefiltered (410) so as to deemphasize artifact affected portions of the signal and transformed (412) to obtain frequency domain information, e.g., red and infrared spectra. The frequency domain information is then processed to compute and display (414) the desired physiological parameters such as pulse rate and SpO<sub>2</sub>.

[0044] While various embodiments of the present invention have been described in detail, it is apparent that further modifications and adaptations of the invention will occur to those skilled in the art. However, it is to be expressly understood that such modifications and adaptations are within the spirit and scope of the present invention.

What is claimed:

1. A method for use in pulse oximetry, comprising the steps of:

receiving an electronic signal reflective of one or more optical signals incident on a detector of a pulse oximeter, wherein said electronic signal includes a first temporal portion that is potentially corrupted by artifact;

processing said signal such that an amplitude associated with said first temporal portion of said signal is reduced in relation to a second temporal portion of said signal, thereby providing a processed signal; and

using said processed signal to obtain physiological information regarding a patient.

2. A method as set forth in claim 1, wherein said step of processing comprises substantially continuously prefiltering said signal so as to reduce any large amplitude portions thereof.

3. A method as set forth in claim 1, wherein said step of processing comprises monitoring said signal to identify said first temporal portion and selectively reducing said amplitude responsive to said step of identifying.

4. A method as set forth in claim 1, wherein said step of processing comprises processing to achieve the effect of multiplying an amplitude value of said signal corresponding to a time within said first temporal portion by a value less than 1.0.

5. A method as set forth in claim 1, wherein said step of processing comprises processing to achieve the effect of multiplying an amplitude value of said signal corresponding to a time within said first temporal time portion by a variable quantity that is inversely proportional to said amplitude.

6. A method as set forth in claim 5, wherein said variable quantity is inversely proportional to a multiple or exponential factor of said amplitude.

7. A method as set forth in claim 1, wherein said step of processing at least said first temporal portion of said signal using a first quantity associated with an amplitude of said first portion of said signal and a second quantity associated with said second portion of said signal.

8. A method as set forth in claim 1, wherein said step of using comprises transforming said processed signal into the frequency domain to obtain spectral information and using such spectral information to obtain said physiological information.

9. A method as set forth in claim 8, wherein said physiological information comprises one of a pulse rate and an arterial oxygen saturation value for said patient.

10. A method for use in pulse oximetry, comprising the steps of:

receiving an electronic signal reflective of one or more optical signals incident on a detector of a pulse oximeter;

identifying, based on an amplitude related analysis of the received signal, an artifact affected portion of said signal; and

applying a correction to reduce an effect of said artifact.

11. A method as set forth in claim 10, wherein said step of identifying comprises repeatedly measuring an amplitude of said received signal to identify a larger amplitude or portion thereof.

12. A method as set forth in claim 10, wherein said step of applying a correction comprises selectively executing an algorithm with respect to data corresponding to said artifact affected portion of said signal.

13. A method as set forth in claim 10, wherein said step of applying a correction comprises prefiltering said received signal to reduce an amplitude of said artifact affected portion of said signal in relation to another portion of said signal.

14. A method for use in pulse oximetry, comprising the steps of:

receiving a time-based signal reflective of one or more optical signals incident on a detector of a pulse oximeter;

performing a correction with respect to a portion of said received time-based signal to reduce an effect of artifact, thereby providing a processed time-based signal;

performing a transform on said processed time-based signal to obtain transformed information relative to a second domain; and

processing the transformed information to obtain physiological information regarding a patient.

15. A method as set forth in claim 14, wherein said step of performing a correction comprises prefiltering said received time based signal to reduce an amplitude of an artifact affected portion of said signal in relation to another portion of said signal.

16. A method as set forth in claim 14, wherein said step of processing comprises performing a spectral analysis to determine one of a pulse rate and an arterial oxygen saturation value for said patient.

17. An apparatus for use in pulse oximetry, comprising:

a port for receiving an electronic signal reflective of one or more optical signals incident on a detector of a pulse oximeter;

a prefilter for filtering said signal such that an amplitude associated with an artifact affected portion of said signal is reduced in relation to a second portion of said signal, thereby providing a process signal; and

a processor for processing said processed signal to obtain physiological information regarding a patient.

18. An apparatus as set forth in claim 17, wherein said port comprises input structure associated with the digital signal processing unit.

19. An apparatus as set forth in claim 17, wherein said prefilter is operative for substantially continuously prefiltering said signal source to reduce any large amplitude portions thereof.

20. An apparatus as set forth in claim 17, wherein said prefilter is operative for monitoring said signal to identify

said artifact affected portion and selectively reducing said amplitude responsive to said identifying.

21. An apparatus as set forth in claim 17, wherein said processor is operative for calculating one of a pulse rate and an arterial saturation value for said patient.

\* \* \* \* \*

专利名称(译)	用于预过滤体积描记信号的系统		
公开(公告)号	<a href="#">US20060293575A1</a>	公开(公告)日	2006-12-28
申请号	US11/250201	申请日	2005-10-14
[标]申请(专利权)人(译)	诺里斯马克		
申请(专利权)人(译)	诺里斯马克		
当前申请(专利权)人(译)	GENERAL ELECTRIC CORPORATION		
[标]发明人	NORRIS MARK A		
发明人	NORRIS, MARK A.		
IPC分类号	A61B5/00		
CPC分类号	A61B5/7207 A61B5/14551		
优先权	60/694767 2005-06-28 US		
其他公开文献	US7403806		
外部链接	<a href="#">Espacenet</a> <a href="#">USPTO</a>		

摘要(译)

在处理之前对脉冲血氧计中的检测器信号进行预滤波，以便确定生理参数值，从而减少信号中伪影的影响。示例性预滤波器将信号幅度值乘以与基本上电流幅度成反比的量子，以便减小通常与伪像相关联的大幅度部分的幅度。在一个实施方式中，该量是与信号的清洁部分相关联的幅度与基本上电流幅度的某个指数因子的比率。以这种方式，在随后的分析中不强调信号的伪影影响部分。

