



(19) **United States**

(12) **Patent Application Publication**
Fraden

(10) **Pub. No.: US 2006/0047214 A1**

(43) **Pub. Date: Mar. 2, 2006**

(54) **WIRELESS MEDICAL PROBE**

(52) **U.S. Cl. 600/513; 600/549; 600/485**

(76) **Inventor: Jacob Fraden, La Jolla, CA (US)**

Correspondence Address:
Jacob Fraden
Advanced Monitors Corporation
125
6215 Ferris Sq.
San Diego, CA 92121 (US)

(57) **ABSTRACT**

A wireless medical transducer that is attached to a patient's body contains one or more sensing assemblies for continuous, wireless and non-invasive monitoring of vital signs. These include EKG, core temperature, arterial blood pressure, arterial blood oxygenation, and others. A transducer may be configured either as a two-unit device where the units are connected by a short cable or a single unit. Sharing various components allows different vital signs to be monitored with greater efficiency. Multiple radio transmitters may operate in the same environment without interfering with each other.

(21) **Appl. No.: 10/924,155**

(22) **Filed: Aug. 24, 2004**

Publication Classification

(51) **Int. Cl.**
A61B 5/04 (2006.01)
A61B 5/02 (2006.01)
A61B 5/00 (2006.01)

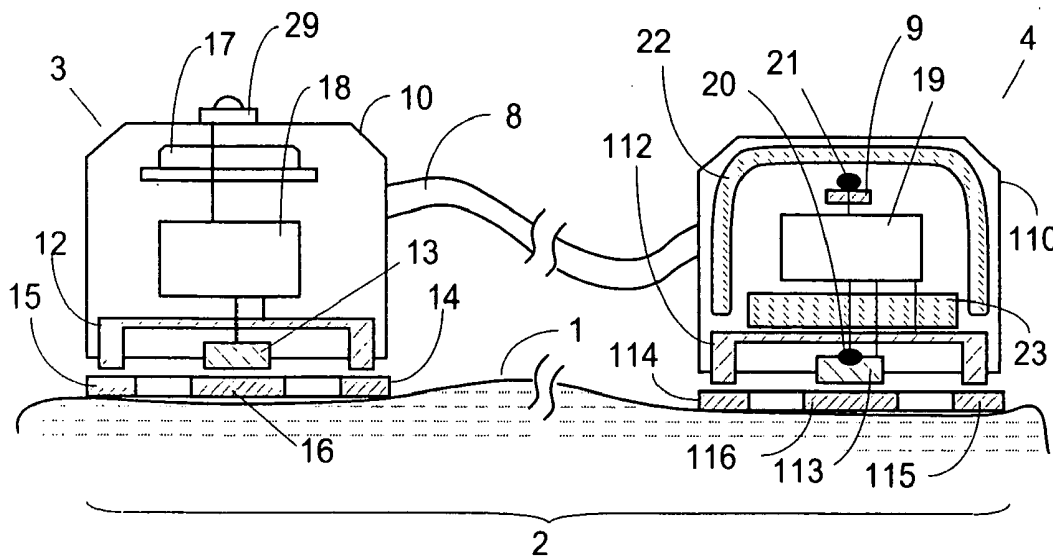

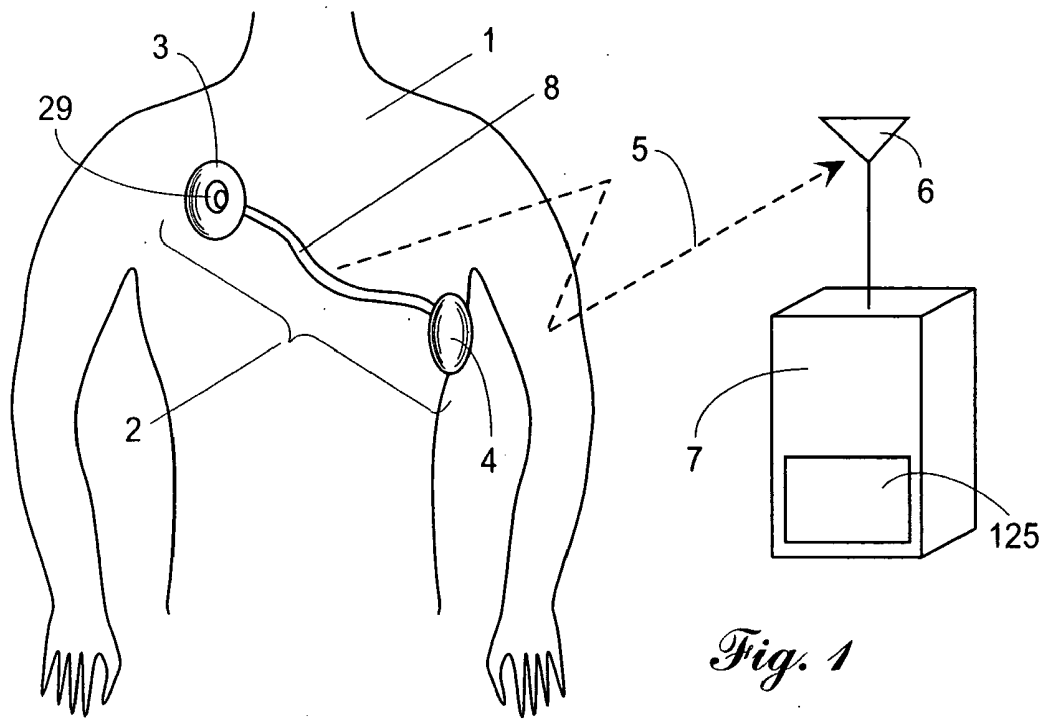

Fig. 1

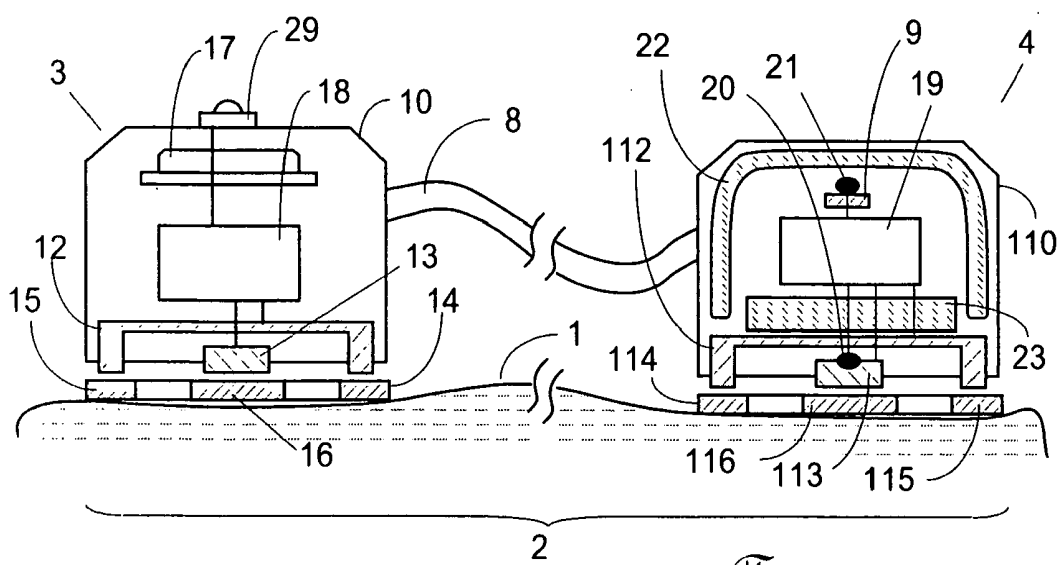
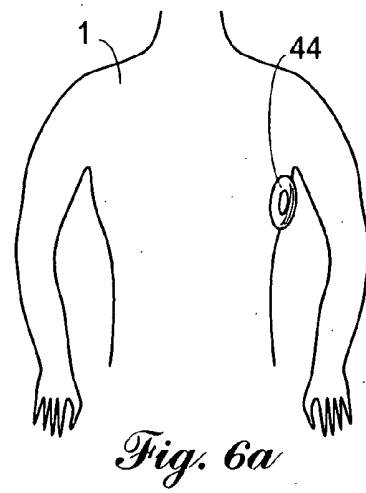
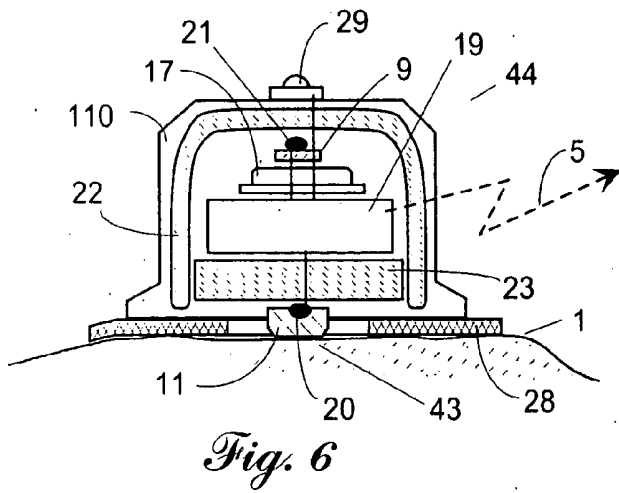
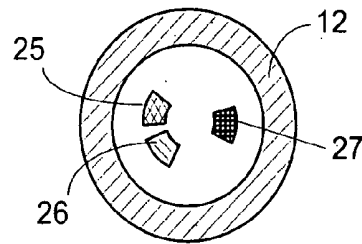
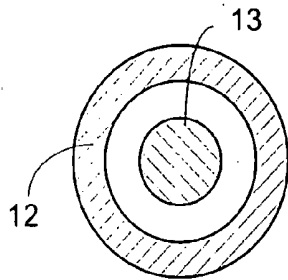
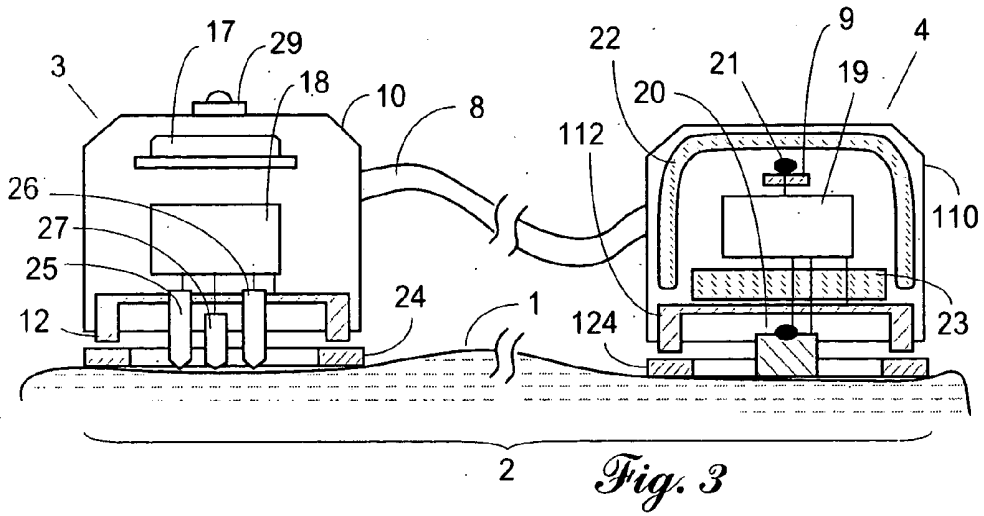

Fig. 2



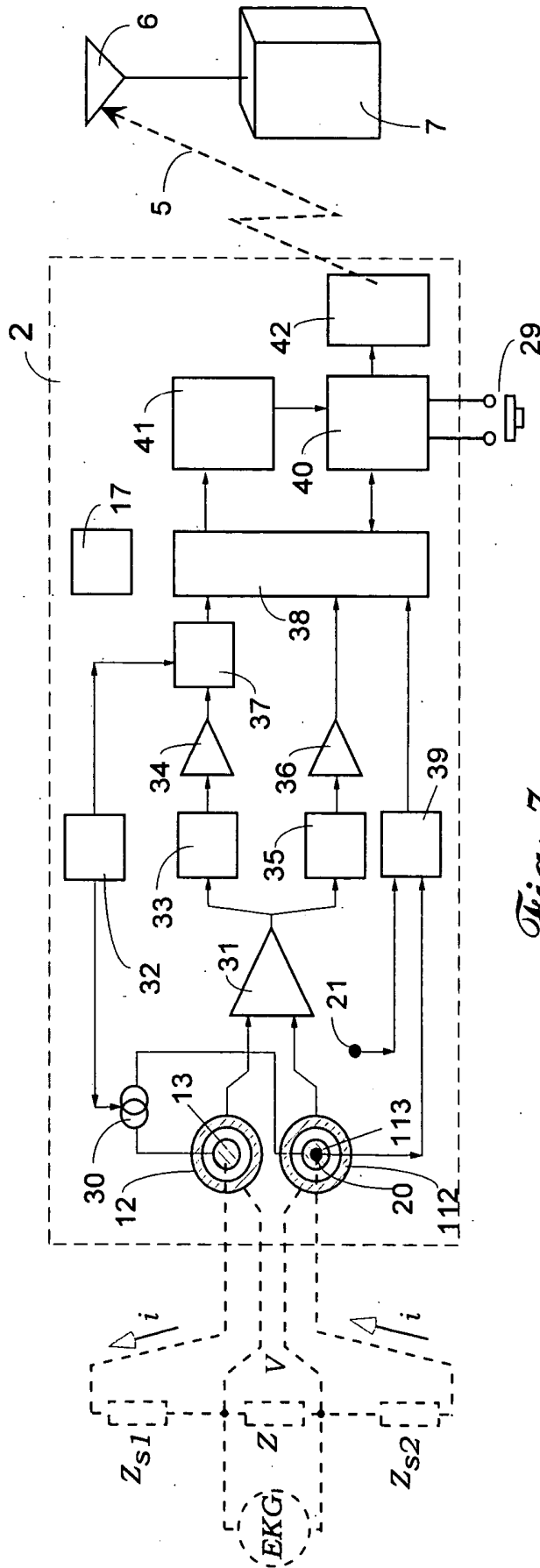

Fig. 7

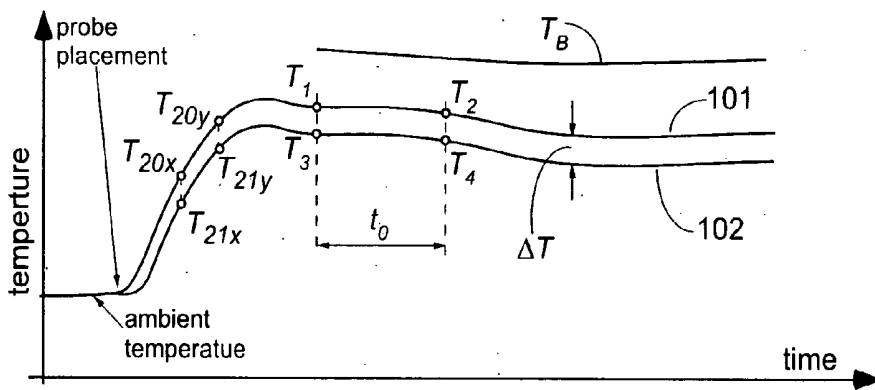

Fig. 8

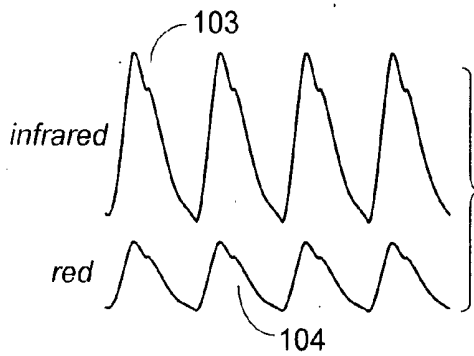

Fig. 9

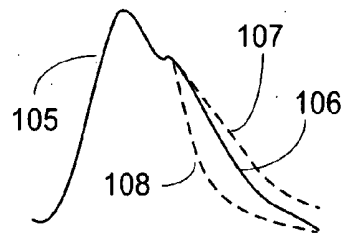

Fig. 10

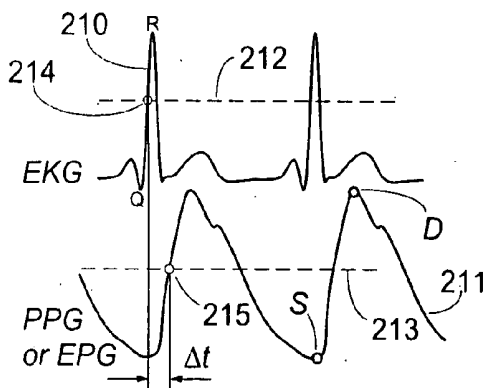

Fig. 11

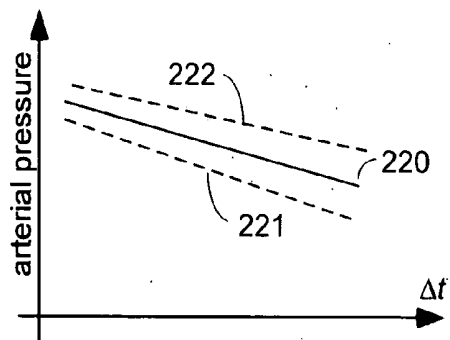
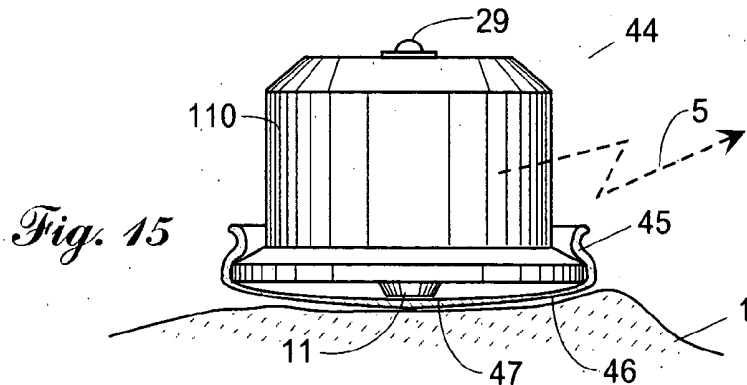
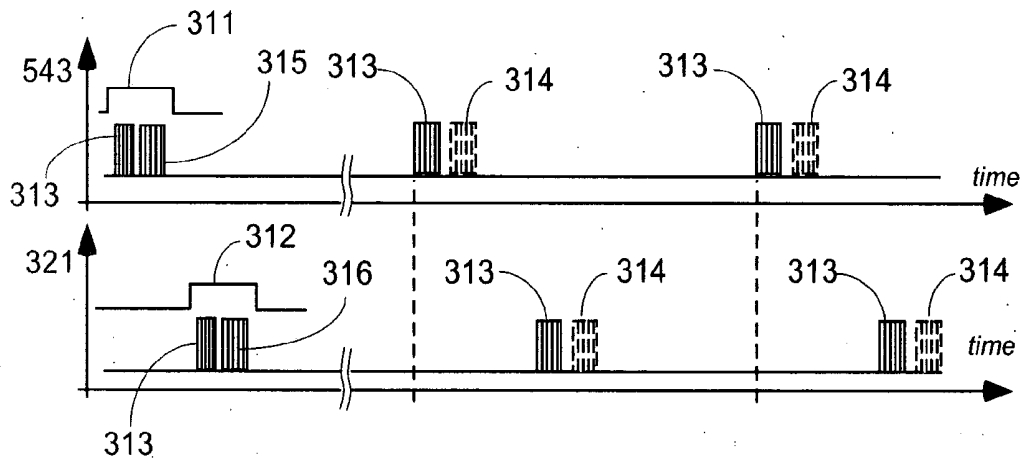
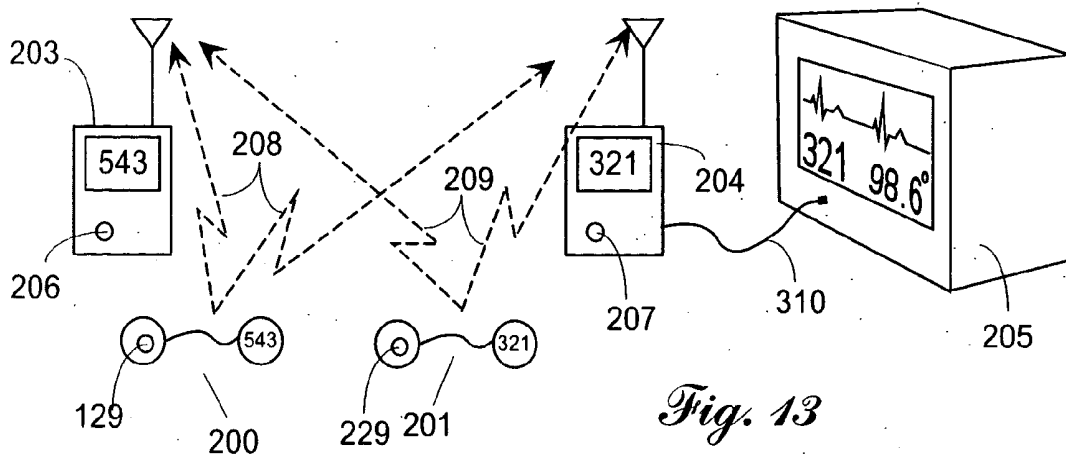

Fig. 12



WIRELESS MEDICAL PROBE

FIELD OF INVENTION

[0001] The present invention relates generally to monitoring of vital signs of a patient, and more particularly to a system and method for monitoring one or more vital signs by means of a wireless communication. The invention is based on U.S. Provisional Patent Application No. 60/493,574 filed on Aug. 8, 2003.

BACKGROUND OF INVENTION

[0002] Devices for measuring various physiological parameters, or “vital signs,” of a patient such as temperature, blood pressure, EKG, etc., have been a standard part of medical care for many years. Indeed, vital signs of some patients (e.g., those undergoing relatively moderate to high levels of care or being in a high risk category) typically are measured on a substantially continuous basis. This enables physicians, nurses and other health care providers to detect sudden changes in a patient’s condition and evaluate a patient’s condition over an extended period of time. Another important application of such devices is a home monitoring of a patient and alarming a care taker of critical changes in a vital sign status. And another possible applications is for the space exploration—continuous monitoring of the astronauts health while in a space vehicle or station. The similar type of a real time field monitoring can be envisioned for a military use when assessment of state of health and well-being of combat personnel may be a critical factor in military operations.

[0003] Since multiple vitals signs should be monitored simultaneously from a patient whose mobility should be limited to a lesser extent possible, it is highly desirable to devise a wireless system with maximum reliability and simplicity. Although a few “mobile” monitoring systems have been attempted, such systems are difficult to use and prone to failure resulting in the loss of a patient’s vital signs data.

DESCRIPTION OF PRIOR ART

[0004] Transmission of medical information is well known in art as a bio-telemetry. It may incorporate a one-way or two-way communication with a monitoring station as is exemplified by U.S. Pat. No. 6,577,893 issued to Besson et al. Numerous devices have been proposed for the wireless patient monitoring. Another example is a wireless temperature monitor according to U.S. Pat. No. 6,238,354 issued to Alvarez.

[0005] Most of devices for wireless transmission of data, as well as devices with wired connection, contain a sensing portion that is geared for monitoring just one and sometimes two vitals signs. The main issue with such sensing devices is incorporation of various sensors into a small package that is to be attached to the patient’s body. Several separate sensors may interfere with one another and thus reduce usefulness of the device. Wireless EGK monitoring is known for nearly 60 years and is one of the easiest vital signs to monitor wirelessly. However, some vital sins detectors don’t lend themselves to easy wireless monitoring due to either large size or inconvenient placement on the patient body or susceptibility to motion artifacts. For example, arterial blood pressure can be monitored either invasively

with indwelled catheters or indirectly by applying an inflatable pressure cuff on an extremity. Neither method is acceptable for a convenient wireless monitoring of a moving patient. Another indirect method of blood pressure monitoring is analysis of a plethysmographic wave as describe in paper published by K. Meigas et al. (*Continuous blood pressure monitoring using pulse wave delay*. In: 2001. Proceedings of the 23rd Ann. EMBS Intern. Conf., Istanbul, Turkey). Yet, the electrode arrangement proposed in the paper requires placement of four electrodes at four separate locations of a patient body which is quite inconvenient. Another example of a vital sign that could be monitored non-invasively is a deep body temperature as taught by U.S. Pat. No. 6,220,750 issued to Palti. While may be effective for a wired monitoring, that device incorporates a heater that requires a sizable power supply which is a serious limitation for a portable wireless device.

[0006] Thus, it is a goal of this invention to provide a small size vital signs probe that can be applied on a patient body;

[0007] Another goal of the invention is to provide a sensing arrangement that can monitor deep body temperature from a surface body with minimum energy requirement from multiple patients;

[0008] And another goal of this invention is to provide a combination electrode for EKG and electroplethysmographic signals that is suitable for a wireless communication;

[0009] It is a further goal of this invention to provide an system for non-invasive monitoring of indirect arterial blood pressure; and

[0010] And the final goal of this invention is to provide a simple reliable multi-channel wireless patient monitoring system.

SUMMARY OF INVENTION

[0011] A combination non-invasive patient monitoring probe comprises one or more physiological transducers with signal conditioning circuits, power supply, data conversion and wireless transmission means. A combination of transducers where some components are shared for obtaining signals allows for simultaneous continuous monitoring of EKG, arterial blood oxygenation, deep body (core) temperature, arterial pressure and other vital signs.

BRIEF DESCRIPTION OF DRAWINGS

[0012] FIG. 1 is a general view of a two-unit wireless monitoring system

[0013] FIG. 2 depicts a cross-sectional view of the probe

[0014] FIG. 3 is a cross-sectional view of the probe with pulse oximetry function

[0015] FIG. 4 is a bottom view of the electrodes

[0016] FIG. 5 shows a bottom view of the electrode and pulse oximetry components

[0017] FIG. 6 depicts a deep body temperature transducer

[0018] FIG. 6a shows a single-unit transducer attached to a patient body

[0019] FIG. 7 is a block-diagram of the wireless monitoring system

[0020] FIG. 8 shows time dependence of two temperature sensors

[0021] FIG. 9 depicts two variable components for the red and infrared portion of a spectrum

[0022] FIG. 10 shows a plethysmographic wave with different decaying slopes

[0023] FIG. 11 depicts a time delay between EKG and plethysmographic wave

[0024] FIG. 12 shows dependence between time delay and arterial pressure

[0025] FIG. 13 show two probe and two receivers operating on the same frequency

[0026] FIG. 14 is a timing diagram of transmitted codes

[0027] FIG. 15 shows attachment of adhesive cap to the transducer

DESCRIPTION OF PREFERRED EMBODIMENT

[0028] Vital sign signals are collected non-invasively from a surface of the patient body 1 by a two-unit probe 2 as shown in FIG. 1. Probe 2 is a combination of first transducer 3, second transducer 4 and link 8 which may be a cable. Both transducers 3 and 4 contain various sensors, detectors, a power supply, and other components that will be described below in greater detail. Probe 2 is a self-containing device that collects, conditions and transmits information via communication link to receiver 7, which receives, processes and makes use of such information. The communication may be provided via a cable (wired), radio or optical (wireless) communication channel. As an illustration, FIG. 1 shows wireless radio signal 5 that enters receiving antenna 6 of receiver 7. Receiver 7 may contain some kind of an output device 125 such as a recorder, display or alarm. Push button 29 is used to initiate operation of probe 2 and for other functions that will be described below.

[0029] It should be noted that a two-unit probe 2 as shown in FIG. 1 is not the only possible configuration of the probe. For some applications, only a one-unit probe is needed (e.g. for temperature only monitoring) while for some vital signs, three or more units linked together may be required. A number of transducers should not construe a limitation of this invention.

[0030] FIG. 2 illustrates a two-unit probe intended for simultaneous collecting of three types of a signal: EKG, electromyographic impedance (Z-value), and deep body (core) temperature (T). Any other combination of such is also possible, for example, EKG and Z-value, EKG and temperature, or temperature alone. It should be noted that EKG requires at least two separated electrodes to be attached to a patient body, Z-signal requires four electrodes: two for passing electric current and two for measuring a voltage drop. Temperature sensing requires one thermal contact attached to the patient body. FIG. 2 depicts the electrodes that share functions for receiving different vital signs and instead of seven contact areas on the body that would be required by the independent vital sign detectors, it has only four such areas within two sensing units.

[0031] Transducers 3 and 4 are housed respectively in first 10 and second 110 housings, and connected together by link 8. That link may provide electrical, optical or a combination of such connections. Bottom portions of housings 10 and 110 are placed on patient's skin 1. In this example, first transducer 3 contains power supply 17, push button 29, first electronic module 19, first EKG electrode 12 and first current electrode 13. Electrodes 12 and 13 are the electro-physiological electrodes that are intended for electrical interfaces with a human body. Thus, these electrodes may need to be fabricated of silver (or silver coated) plates with the outer AgCl coating as it is commonly done for such electrodes. To make an electrical contact with a human body, an electrically conductive gel pads may be also required. For practical use, these pads should have adhesive layers. First adhesive pad 14 contains first EKG pad 15 and first current pad 16. The adhesive portion is not shown in FIG. 2. It is important that pad 14 makes a good electrical contact between patient body 1 and electrodes 12 and 13. The silver-silver chloride electrodes and the interface gel pads are well known in art and are not described here in detail. FIG. 4 shows a bottom view of transducers 3 and 4 of FIG. 2.

[0032] To obtain both the EKG and Z-signal, another set of electrodes is required. This is provided by second transducer 4 which has the identical second EKG electrode 112, second current electrode 113 and the corresponding second adhesive pad 114 with second EKG pad 115 and second current pad 116. Here second current electrode 113 is somewhat different from first current electrode 13 because electrode 113 has attached to it first temperature sensor 20. Second current electrode 113 and first temperature sensor 20 must be in the intimate thermal contact. Further, second current pad 116 must be thin (about 0.001-0.005") to minimize its thermal resistance and improve thermal coupling to patient body 1. Deep body (core) temperature of the patient can't be measure by first temperature sensor 20 alone because of influence of the ambient temperature. For computation of a deep body temperature, second transducer 4 is provided with second temperature sensor 21, outer insulator 20, and inner insulator 23. To improve stability of second temperature sensor 21, it can be attached to a metal plate 9.

[0033] All electrodes and temperature sensors are connected to the appropriate circuits inside the first and second electronic modules 18 and 19 respectively. The circuits get operating energy from power supply 17. One of the electronic modules incorporates a communication device which may be a radio transmitter.

[0034] For the operational description of probe 2 refer to FIG. 7 which is a block diagram of a two-unit probe. On the left side of the diagram, there is an equivalent circuit of the patient body shown with dotted lines. Probe 2 of FIG. 7 receives and processes three vital signs: EKG, electromyogram (EPG or Z-signal) and core temperature. Z-signal is a resistive component Z of the body internal electrical impedance. It depends on the body fluid content, cardiac output, peripheral vascular resistance and other variables. The EKG signal is generated by heart. Temperature is the result of cellular metabolism, the body physiological activity and other factors.

[0035] The circuit operates as follows. Oscillator 32 running at a typical frequency in the range from 10 kHz to 100

kHz controls a.c. current source **30** that forces current i into the patient's body through first and second current electrodes **13** and **113** respectively. Since the skin impedances Z_{s1} and Z_{s2} have strong capacitive components, most of the a.c. voltage drop develops over the internal resistive component Z . Voltage V is the sum of the a.c. voltage drop over resistance Z and the EKG voltage originated from the patient's heart. That combined voltage is picked-up by first and second EKG electrodes **12** and **112** respectively and passed to a broadband pre-amplifier **31**. The output of the preamplifier is fed into two filters. The first one is high-pass filter **33** that allows a passing only of the frequencies corresponding to oscillator **32** and not of EKG. These frequencies are further amplified by first amplifier **34** and applied to synchronous demodulator **37** that is controlled by oscillator **32**. The output low frequency signal from demodulator **37** represents value Z which is commonly called electroplethysmographic or reographic signal. It is fed into multiplexer **38** which is an analog gate. The low frequency components corresponding to the EKG signals pass from pre-amplifier **31** to low-pass filter **35**, second amplifier **36** and subsequently to the same multiplexer **38**. Thus, high frequency components of the spectrum originated in oscillator **32** are blocked out.

[0036] Signals from first and second temperature sensors **20** and **21** respectively are conditioned by temperature circuit **39** and also pass to multiplexer **38**. Microcontroller **40** controls multiplexer **38**, analog-to-digital (A/D) converter **41** and transmitter **42**. The multiplexed signals in a digital format are transmitted to receiver **7** along with some other related information from probe **2**, such as the probe identification (I.D) number, calibrating constants, etc. It should be noted that microcontroller **40** may incorporate memory that accumulates vital signs information for some time and then transmits it to receiver **7** in compact bundles on a periodic basis, say once every minute. This allows to minimize power consumption and reduce continuous transmission time.

[0037] To reduce power consumption, oscillator **32** may generate low duty-cycle pulses rather than continuous oscillation. This would force short current pulses through impedance Z and the average current supplied by the battery is greatly reduced. Alternatively, oscillator **32** may be controlled by the EKG signal from amplifier **36**, thus measuring impedance only during the intervals that are required for data processing, for example, immediately after the R-wave of EKG.

[0038] In most applications, for example in a hospital room or while monitoring astronauts in flight, several radio-transmitting probes may need to operate in close proximity to one another. Even if the transmitted power is low, there is still a probability that the information may be picked up by the wrong receiver because all transmitters may operate within the same radio bandwidth. Besides reducing transmitting power, two other methods are used to prevent the cross-reception. One is a time division and the other is coding.

[0039] Time division works as follows. Each transmitter sends information in short packets with a low duty cycle. For example, a transmission may take 0.6 s with 1 minute intervals which is equivalent to duty cycle of 1%, meaning that there is only 1% probability that a signal from one

transmitter will coincide with the signal from the second transmitter. The duty cycles may be made randomly variable, so that a probability of the respective overlapping becomes even smaller.

[0040] The coding method works as follows. Each transmitter is assigned at a factory a unique ID code. FIG. 13 illustrates two probes **200** and **201** operating within the same space and transmitting the corresponding radio signals. **208** and **209** on the same frequency which can be picked up by both receivers **203** and **204**. As an illustration, the first receiver **203** is a self-containing device with a display and the second receiver **204** is an interface device between probe **201** and bedside monitor **205** which is connected to second receiver **204** by cable **310**. Before operation, a set-up procedure for each pair (probe-receiver) is required. This can be accomplished by establishing the initial set-up communication, first between probe **200** and receiver **203** and then between second probe **201** and its receiver **204**. Momentary switch **206** on receiver **203** is depressed which sets strobe **211** (see FIG. 14) inside that receiver making the receiver receptive to a set-up procedure. After that, push button **129** (the same as pushbutton **29** in FIGS. 1-3) on probe **200** is depressed. In response, probe **200** transmits its unique ID code **313** and the set-up code **315**. In this example, transmitter **200** has the ID code "543". Receiver **203** receives the code and sets itself to be receptive only to data that carry that particular code. Note that since switch **207** on second receiver **204** was not depressed at that particular time, receiver **204** ignores the set up procedure for probe **200**. However, receiver **204** is coded in a similar manner by using switch **207** and pushbutton **229** on second probe **201**. In a similar manner, this sets receiver **204** to be receptive only to probe **201** that has a unique ID code ("321" in the example). From that moment on, probes **200** and **201** go to operation mode and transmit medical information codes **314** accompanied by their unique ID codes **313**. The coding forces each receiver to accept only information codes **314** from the corresponding probe and ignore other transmissions that have different ID codes.

[0041] To preserve energy contents of power supply **17** in probe **2** (FIG. 7) while not in use, signals from first and second temperature sensors **20** and **21** respectively are compared with each other and if they indicate a very small temperature gradient, say less than 0.5 degree C. for a prolonged period of time of all hour or more, this will indicate that probe **2** is no longer attached to a patient. Another possible way to detect disconnection from a patient is monitoring of current i . If this current drops to zero, a patient is no longer connected. In this cases, power of probe **2** can be automatically shut down by microcontroller **40**. It can be restored by depressing pushbutton **29**.

[0042] Another possible configuration of probe **2** is shown in FIG. 3. Instead of the Z -value (EPG), it detects two photo-plethysmographic (PPG) signals at two different light wavelengths, say in red and infrared (IR). First transducer **3** now contains the optical components: first LED **25** (red), second LED **26** (IR) and light detector **27**. Detecting photo-plethysmogram at these two wavelengths allows computation of the arterial blood oxygenation which is known in art as pulse oximetry. The optical components as identified above are positioned adjacent to the EKG electrode, for example, inside of a circular EKG electrode **12** as shown in FIG. 5. The pulsating components which are modulated by

light passing to and reflecting from the patient's body are measured and transmitted to the receiver. The detected red and IR signals, **104** and **103** respectively, have different magnitudes as shown in **FIG. 9**. The ratio of these magnitudes is commonly used to compute the degree of oxygen saturation of hemoglobin, SpO₂, in arterial blood. We do not describe this process further as such computation is well known in art of patient monitoring

[0043] Since receiver **7** receives the EKG and either EPG or PPG signals, these two signals can be used to compute the arterial blood pressure by using one of the following methods. In the first method, only either EPG or PPG is analyzed. The decaying (back) slope of the detected EPG or PPG wave (**FIG. 10**) correlates with the peripheral vascular resistance of the circulatory system and, subsequently, with the mean arterial blood pressure. The slower decaying slope **107** indicates higher mean arterial blood pressure, the faster decaying slope **108** is an indication of a lower pressure, whereas a medium slope **106** indicates a normal blood pressure. Another way of computing the mean blood pressure is to measure time delay between the rapid portions of EKG and the EPG or PPG waves as shown in **FIG. 11**. Time delay Δt of the EPG (PPG) can be measured with respect to either Q or R waves of the EKG. Two thresholds **212** and **213** cross the EKG and EPG (PPG) waves at the corresponding points **214** and **215**, allowing measurement of Δt . **FIG. 12** illustrates dependence of mean arterial pressure **220** of time delay Δt . The systolic pressure **222** and diastolic pressure **221** can be estimated from the extreme corresponding points S and D on the PPG or EPG wave (see **FIG. 11**) by a proportional scaling. Naturally, these methods require an individual patient calibration against one of the conventional blood pressure measurements. The measurements as indicated above can be performed by microcontroller **40** or, preferably, inside receiver **7**.

[0044] As it was indicated above, depending on the application, probe **2** may be configured in multiple ways. One common application is a deep body temperature sensing. A single-unit temperature probe is shown in **FIG. 6** as transducer **44**. In many respects it is identical to transducers **4** in **FIGS. 2 and 3**, except that it contains no electrodes, because now its purpose is only the temperature monitoring. Second housing **110** contains outer and inner insulators **22** and **23** respectively, first and second temperature sensors **20** and **21**, second electronic module **19** and power supply **17**. The probe may be attached to patient's body **1** by a double-sided adhesive disk **28** (see also **FIG. 6a**). In the lower center of transducer **44**, there is metal contact **11** attached to first temperature sensor **20**. Temperature sensors may be thermistors, semiconductors or, alternatively, one of them may be a thermocouple junction, while the other such junction must be thermally attached to another temperature sensor.

[0045] **FIG. 15** shows an alternative way of attaching transducer **44** to the patient's body **1**. Here cap **45** has an adhesive bottom **46**. The cap is snapped onto transducer **44** and holds it on patient's **1** skin. Lower portion **47** of cap **45** is thin (on the order of 0.001") so that its thermal conductivity is rather high, much higher than that of patient's skin. The cap may be fabricated by a thermo-forming process from polypropylene or any other suitable material.

[0046] A deep body temperature is measured as follows. Since first temperature sensor **20** is in an intimate thermal

contact with the patient body (**FIG. 6**), it measures temperature of patient's skin **43** which commonly is cooler than the core temperature. Second temperature sensor **21** is removed from first temperature sensor **20** and insulated from it by inner insulator **23**. Thus, second temperature sensor **21** measures the interior temperature of the transducer. Insulators **22** and **23** may be just the air gaps near the corresponding temperature sensors. Plate **9** attached to that sensor helps to improve its thermal stability. **FIG. 8** shows time changes of temperature **101** measured by first temperature sensor **20** and temperature **102** measured by second temperature sensor **21**. After the probe placement on the patient body, both temperatures increase above ambient, though there is a thermal gradient $\Delta T = T_{101} - T_{102}$ between them. This thermal gradient is a measure of the heat flow from a deep body interior to the first and subsequently to the second temperature sensors **20** and **21**. On the basis of the Newton's law of cooling, the deep body temperature may be computed from temperatures **101** and **102** as

$$T_B = T_{101} + \mu \Delta T \quad (1)$$

where μ is the experimentally calibrated factor, typically ranging from 1.5 to 3. It should be noted that its value may also depend on both T_{101} and T_{102} , so for a higher accuracy a more complex function needs to be employed to compute core temperature. An example of such a function is

$$T_B = AT_{101}^2 + (B + CT_{102})T_{101} + DT_{102} + B \quad (2)$$

where A, B, C, D and E are the experimentally determined constants.

[0047] While the above description contains many specifics, these specifics should not be construed as limitations on the scope of the invention, but merely as exemplifications of preferred embodiments thereof. Those skilled in the art will envision many other possible variations that are within the scope and spirit of the invention.

1. A medical monitor for collecting, transmitting and receiving vital signs from surface of a patient body contains in combination

- a first probe housing;
- a first bottom portion of the first probe housing that contacts patient body;
- a first sensor of a vital sign positioned adjacent to said first bottom portion;
- a first electronic module positioned internally to first probe housing;
- transmitter of electromagnetic radiation positioned internally to first probe housing;
- a power supply positioned internally to first probe housing;
- receiver of electromagnetic radiation that is detached from the first probe housing;
- output device connected to said receiver.

2. A medical monitor of claim 1 further comprising a second probe housing attached to patient body and containing

- a second sensor of a vital sign
- second electronic module

a link for connecting to said first electronic module.

relating arterial blood pressure to said time delay

3. A medical monitor of claim 1, where

a first sensor is a first temperature sensor that is thermally insulated from said outer portion of the probe housing;

said probe housing further comprising a second temperature sensor positioned inside said probe housing and thermally insulated from first temperature sensor

4. A method of computing arterial pressure of a patient comprising steps of

obtaining EKG signal

obtaining plethysmographic signal

transmitting EKG and plethysmographic signals to a processing means;

measuring time delay between a rapid wave of the EKG signal and rapid slope of the plethysmographic signal

relating the measured time delay to patient's arterial pressure

5. A method of computing arterial pressure of a patient comprising steps of

obtaining plethysmographic signal;

transmitting plethysmographic signals to a processing means;

measuring rate of a decaying slope of a plethysmographic signal;

relating said rate to patient's arterial pressure

* * * * *

| | | | |
|----------------|--|---------|------------|
| 专利名称(译) | 无线医疗探头 | | |
| 公开(公告)号 | US20060047214A1 | 公开(公告)日 | 2006-03-02 |
| 申请号 | US10/924155 | 申请日 | 2004-08-24 |
| [标]申请(专利权)人(译) | FRADEN JACOB | | |
| 申请(专利权)人(译) | FRADEN JACOB | | |
| 当前申请(专利权)人(译) | FRADEN JACOB | | |
| [标]发明人 | FRADEN JACOB | | |
| 发明人 | FRADEN, JACOB | | |
| IPC分类号 | A61B5/04 A61B5/02 A61B5/00 | | |
| CPC分类号 | A61B5/0002 A61B5/021 G01K13/002 A61B2560/0219 G01K7/42 A61B5/02125 G01K7/427 | | |
| 外部链接 | Espacenet USPTO | | |

摘要(译)

连接到患者身体的无线医疗换能器包含一个或多个传感组件，用于对生命体征进行连续，无线和非侵入性监测。这些包括心电图，核心温度，动脉血压，动脉血氧合等。换能器可以配置为双单元设备，其中单元通过短电缆或单个单元连接。共享各种组件可以更高效地监控不同的生命体征。多个无线电发射机可以在相同的环境中操作而不会相互干扰。

