



(19) **United States**

(12) **Patent Application Publication**

**Hickle**

(10) **Pub. No.: US 2003/0145854 A1**

(43) **Pub. Date: Aug. 7, 2003**

(54) **APPARATUSES AND METHODS FOR AUTOMATICALLY ASSESSING AND MONITORING A PATIENT'S RESPONSIVENESS**

**Publication Classification**

(51) **Int. Cl.<sup>7</sup> ..... A61M 16/00**  
(52) **U.S. Cl. .... 128/204.18; 128/204.23**

(75) **Inventor: Randall S. Hickle, Lubbock, TX (US)**

Correspondence Address:  
**HOGAN & HARTSON LLP  
IP GROUP, COLUMBIA SQUARE  
555 THIRTEENTH STREET, N.W.  
WASHINGTON, DC 20004 (US)**

(73) **Assignee: Scott Laboratories, Inc.**

(21) **Appl. No.: 10/329,763**

(22) **Filed: Dec. 27, 2002**

**Related U.S. Application Data**

(63) **Continuation-in-part of application No. 09/324,759, filed on Jun. 3, 1999.**

(60) **Provisional application No. 60/087,841, filed on Jun. 3, 1998. Provisional application No. 60/342,773, filed on Dec. 28, 2001.**

(57) **ABSTRACT**

A care system and associated methods are provided for alleviating patient pain, anxiety and discomfort associated with medical or surgical procedures. The care system facilitates a procedural clinician's safely and efficaciously providing sedation and analgesia and in some measure, amnesia to a patient by providing a responsiveness monitoring system which monitors the responsiveness of the patient and generates a value representing the level of patient responsiveness. In further aspects of the invention, the responsiveness monitoring system is an automated system which includes patient query and response devices. Additional embodiments of the system and methods are directed to alleviating patient pain or discomfort while enabling safe drug delivery (automated, clinician-controlled or patient-controlled) in correlation with the monitoring of patient health conditions.

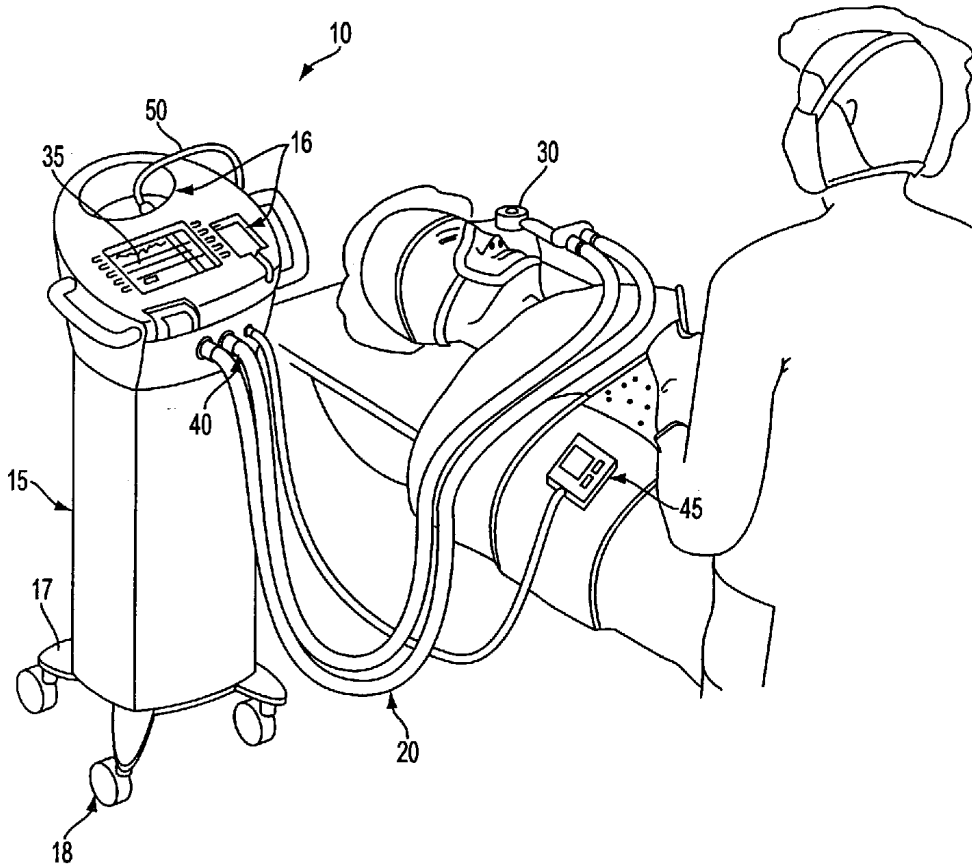

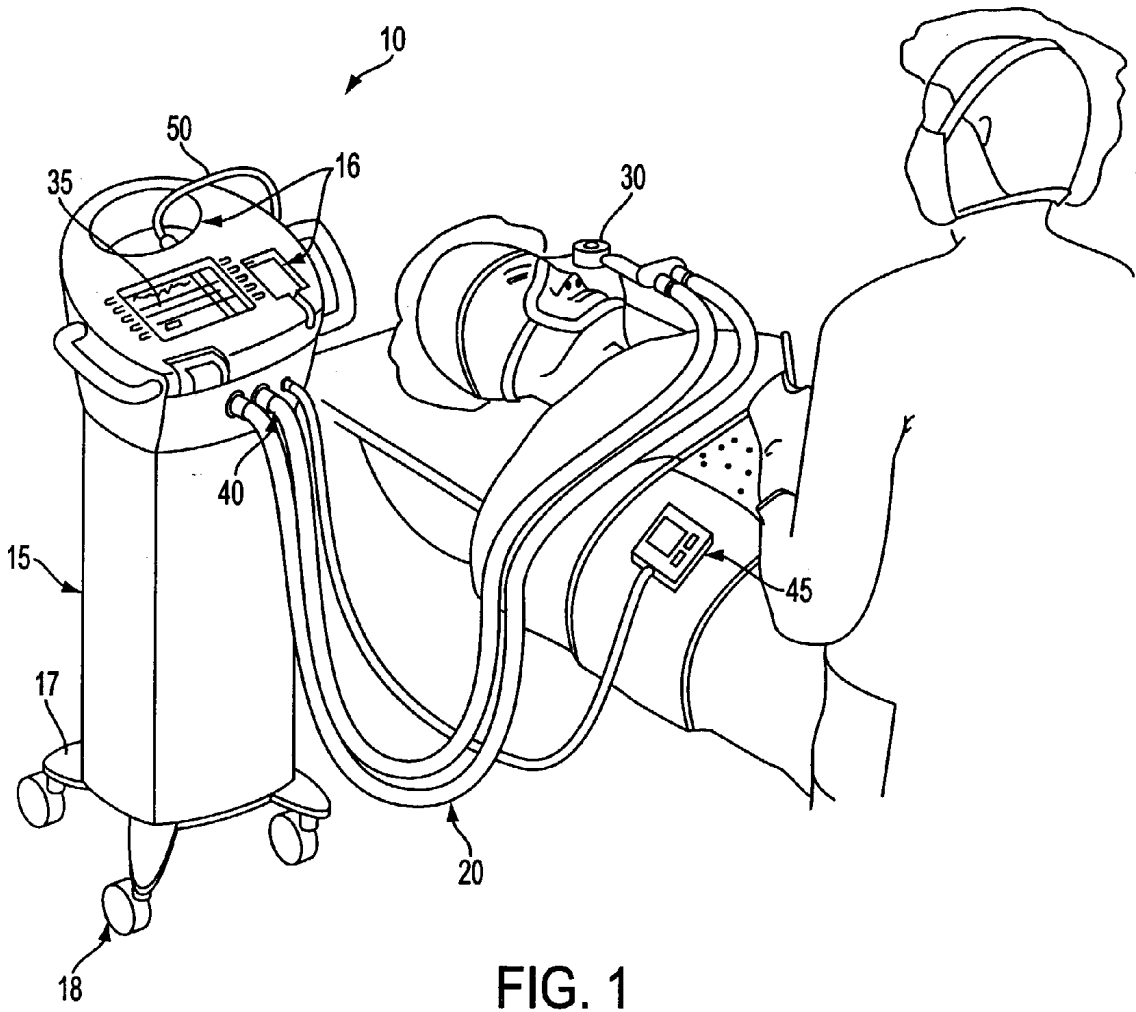

FIG. 1

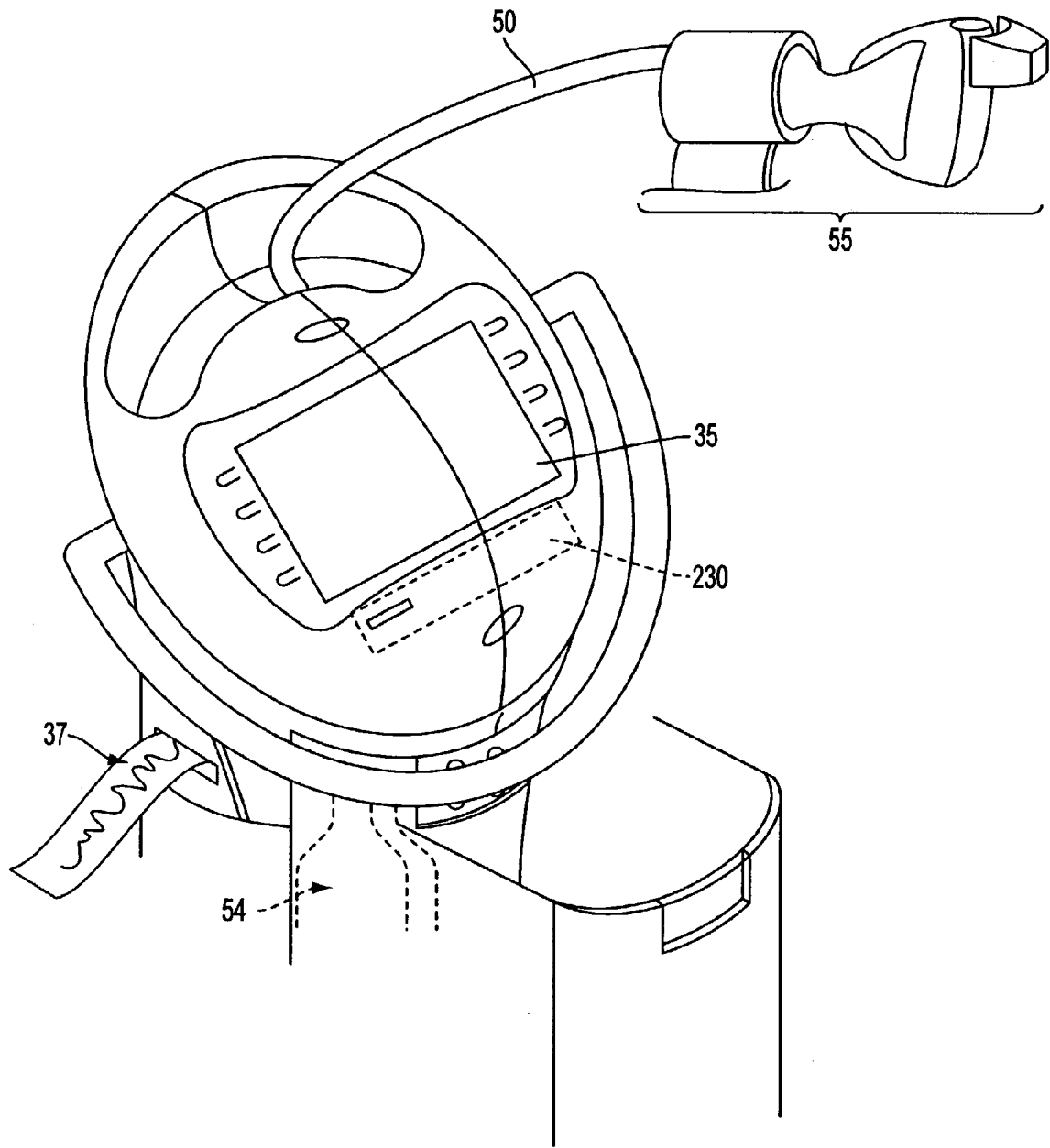

FIG. 2

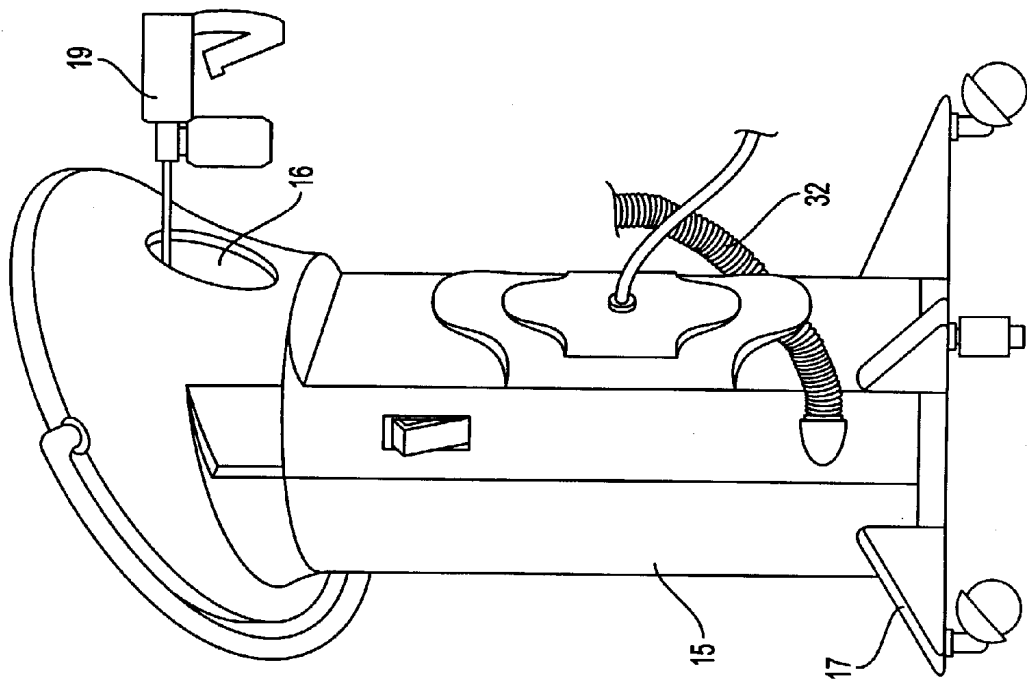

FIG. 3B

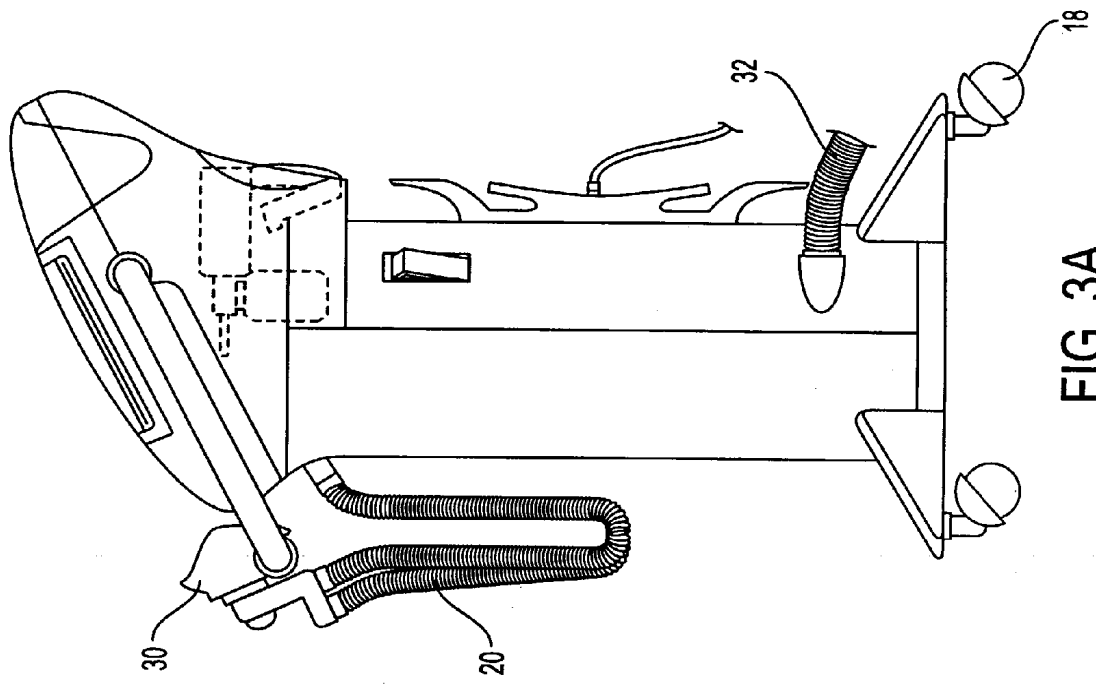

FIG. 3A

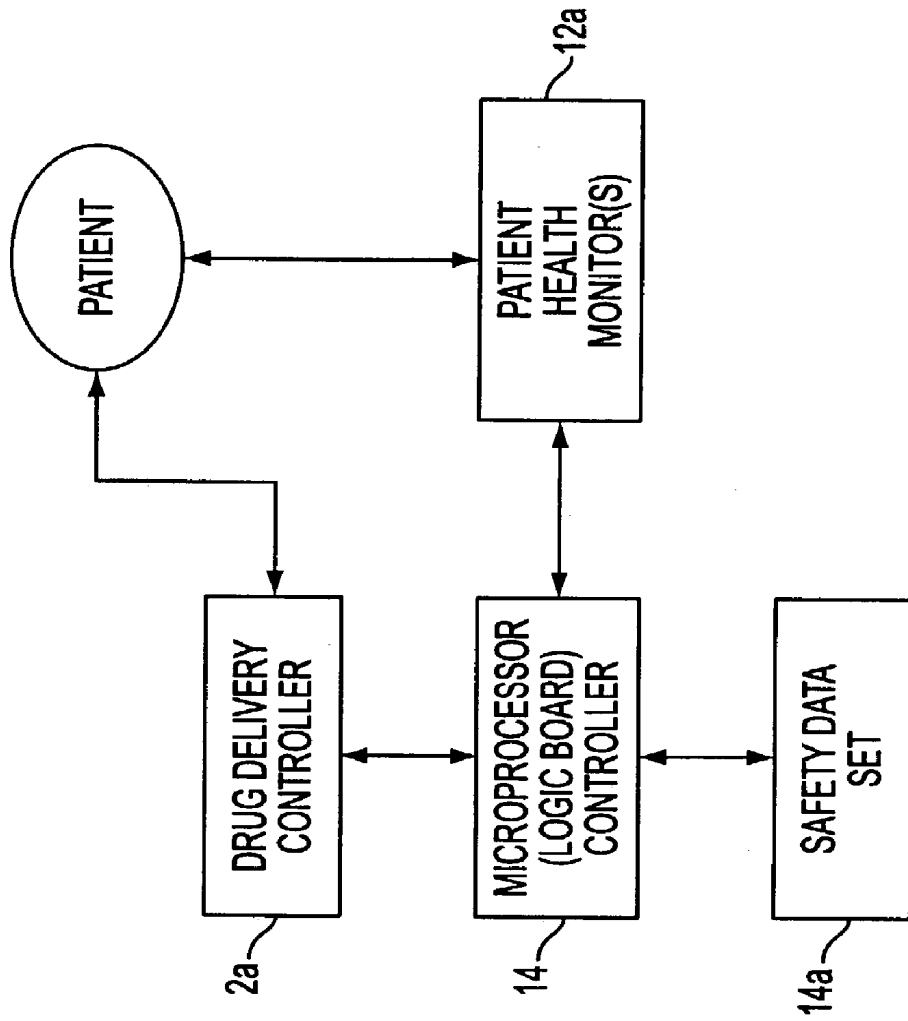

FIG. 4A

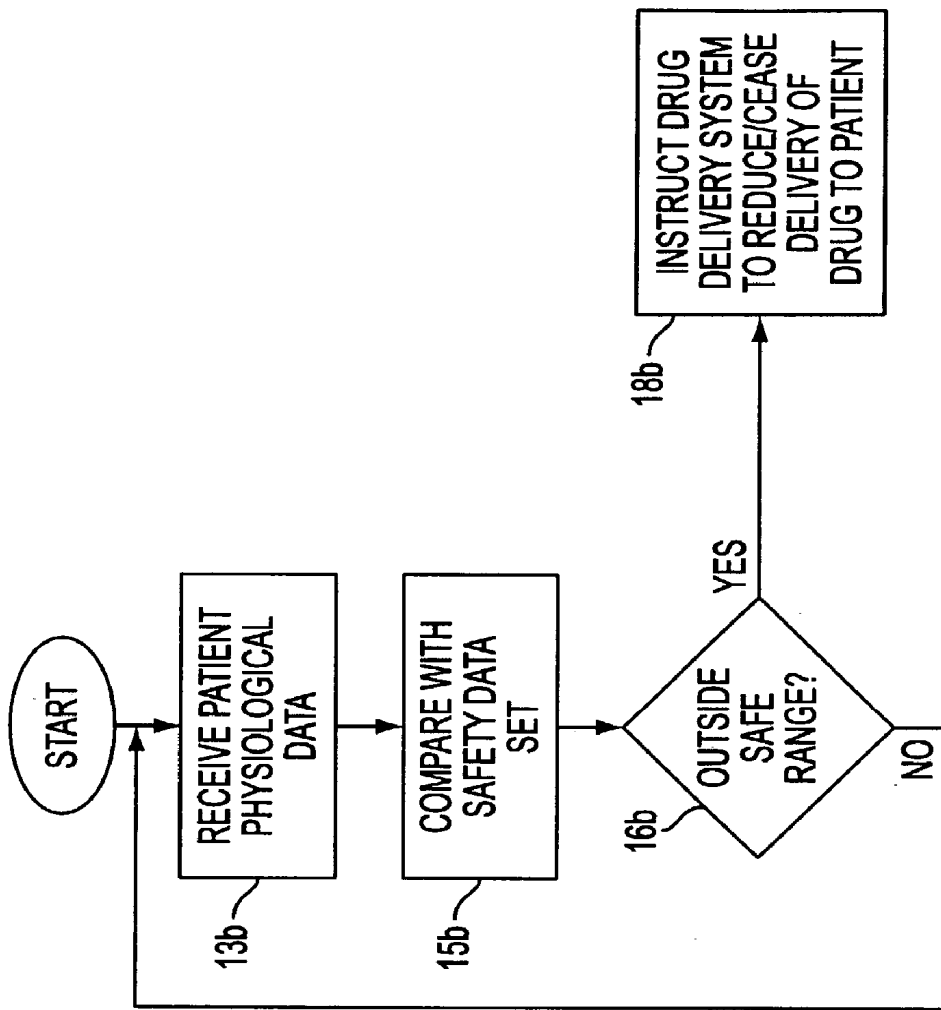

FIG. 4B

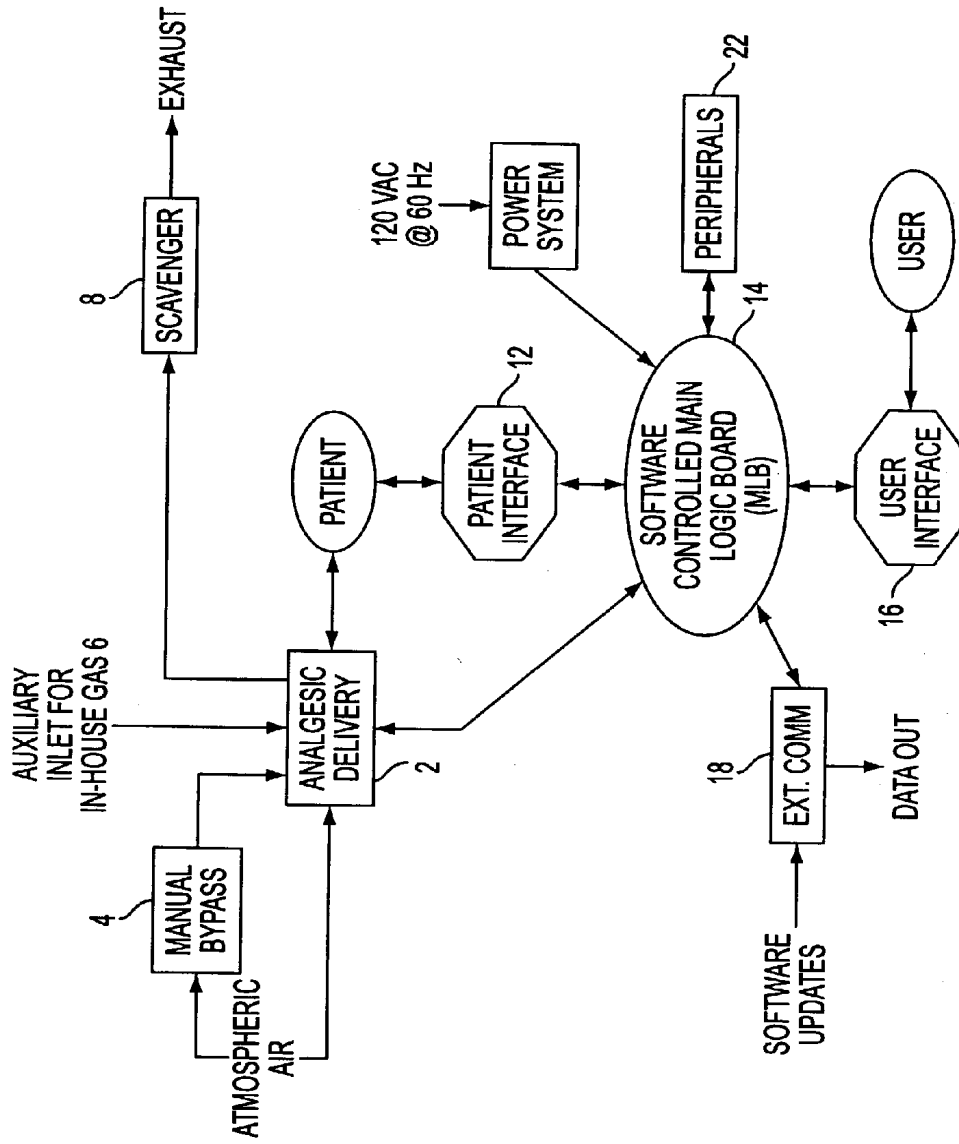

FIG. 5

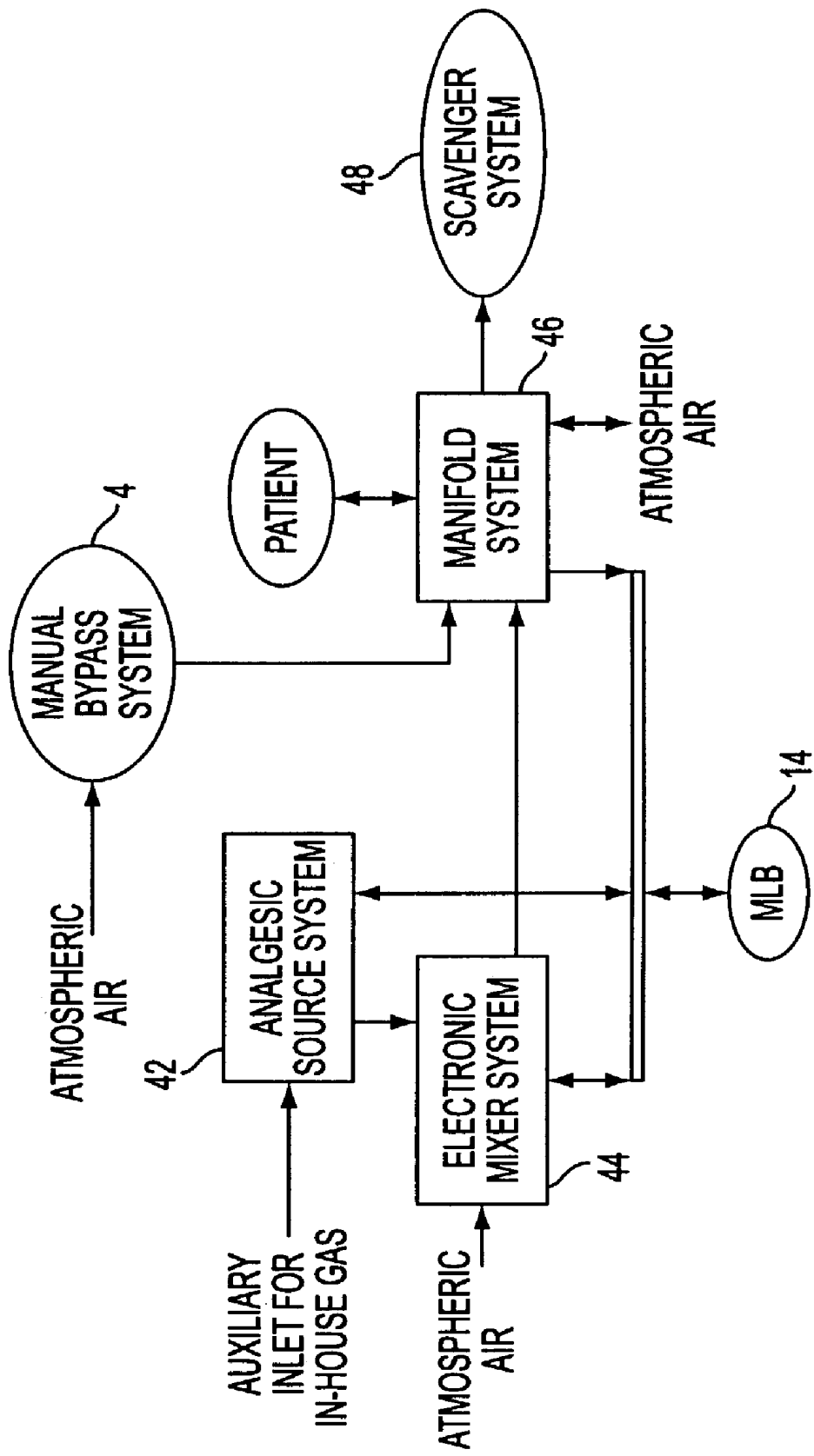

FIG. 6

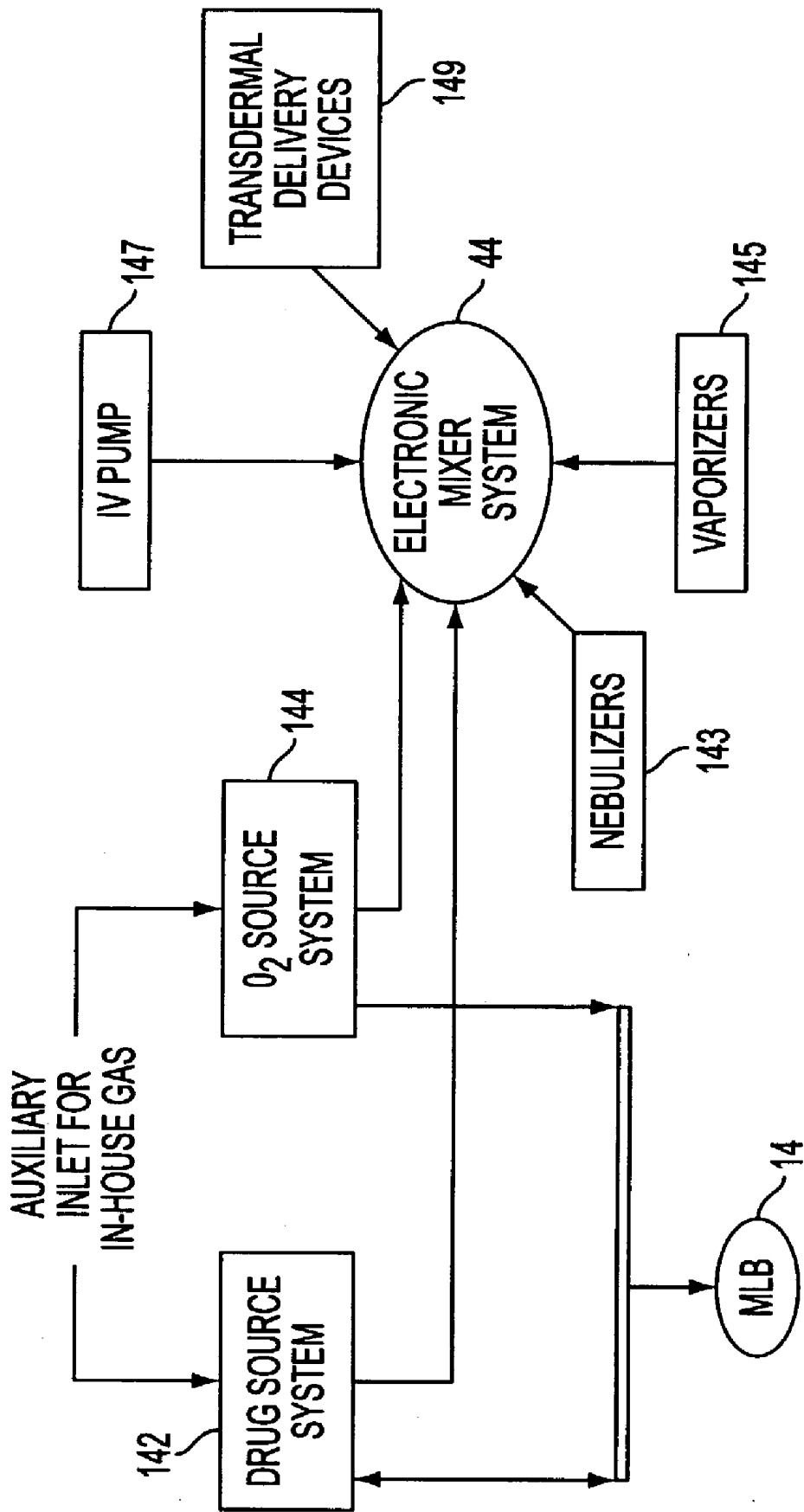

FIG. 7A

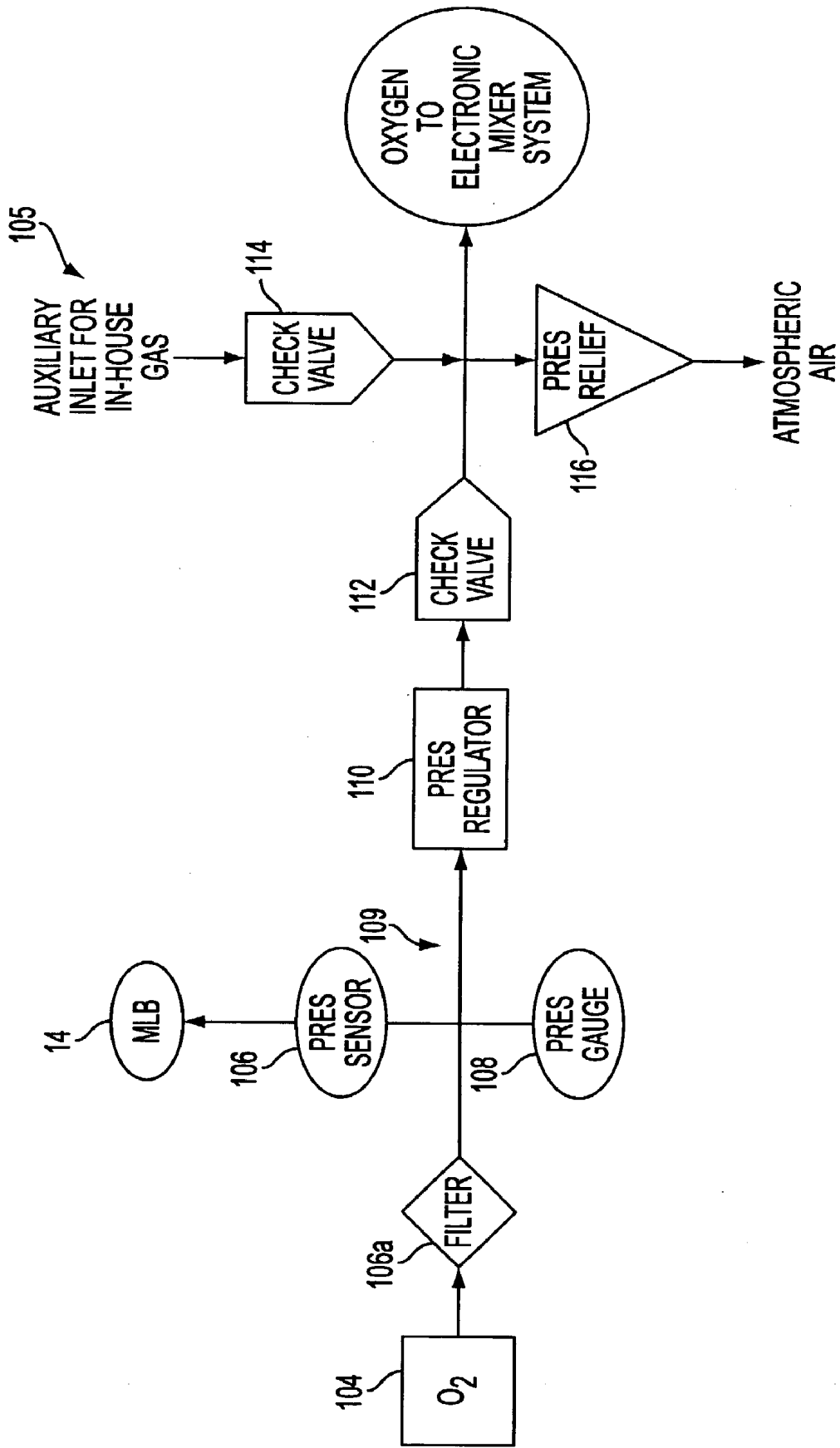

FIG. 7B

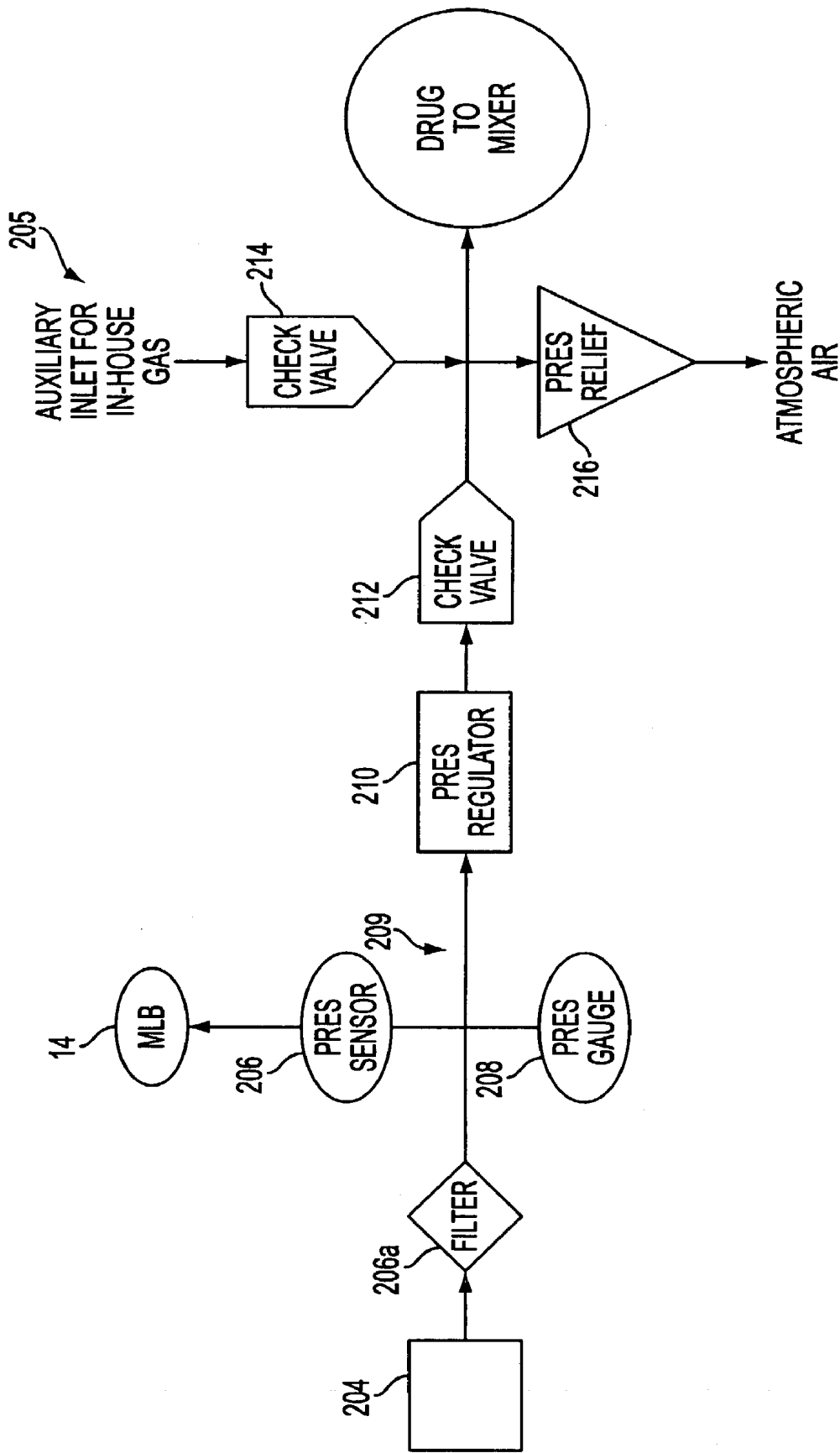

FIG. 7C

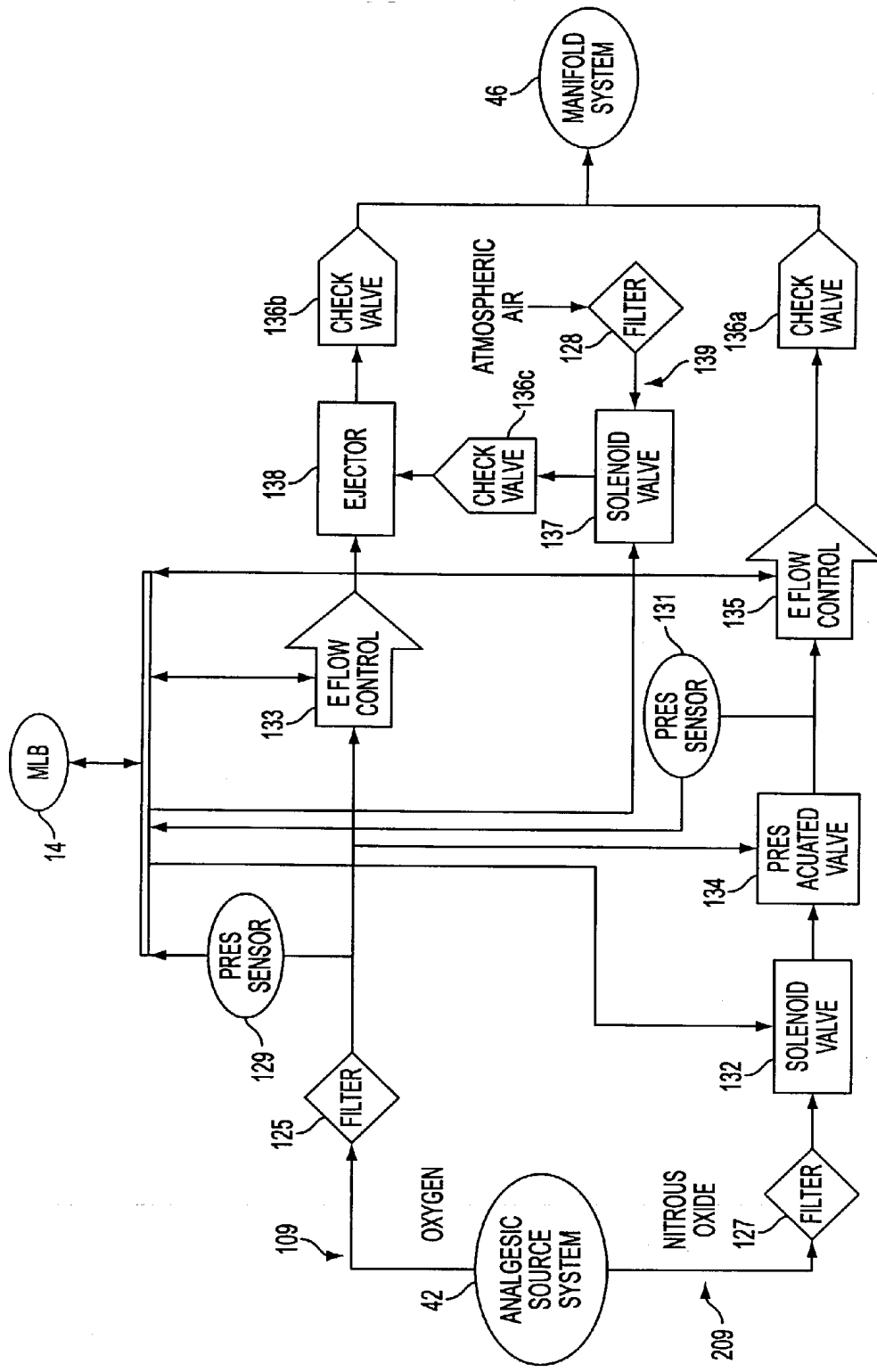

FIG. 8



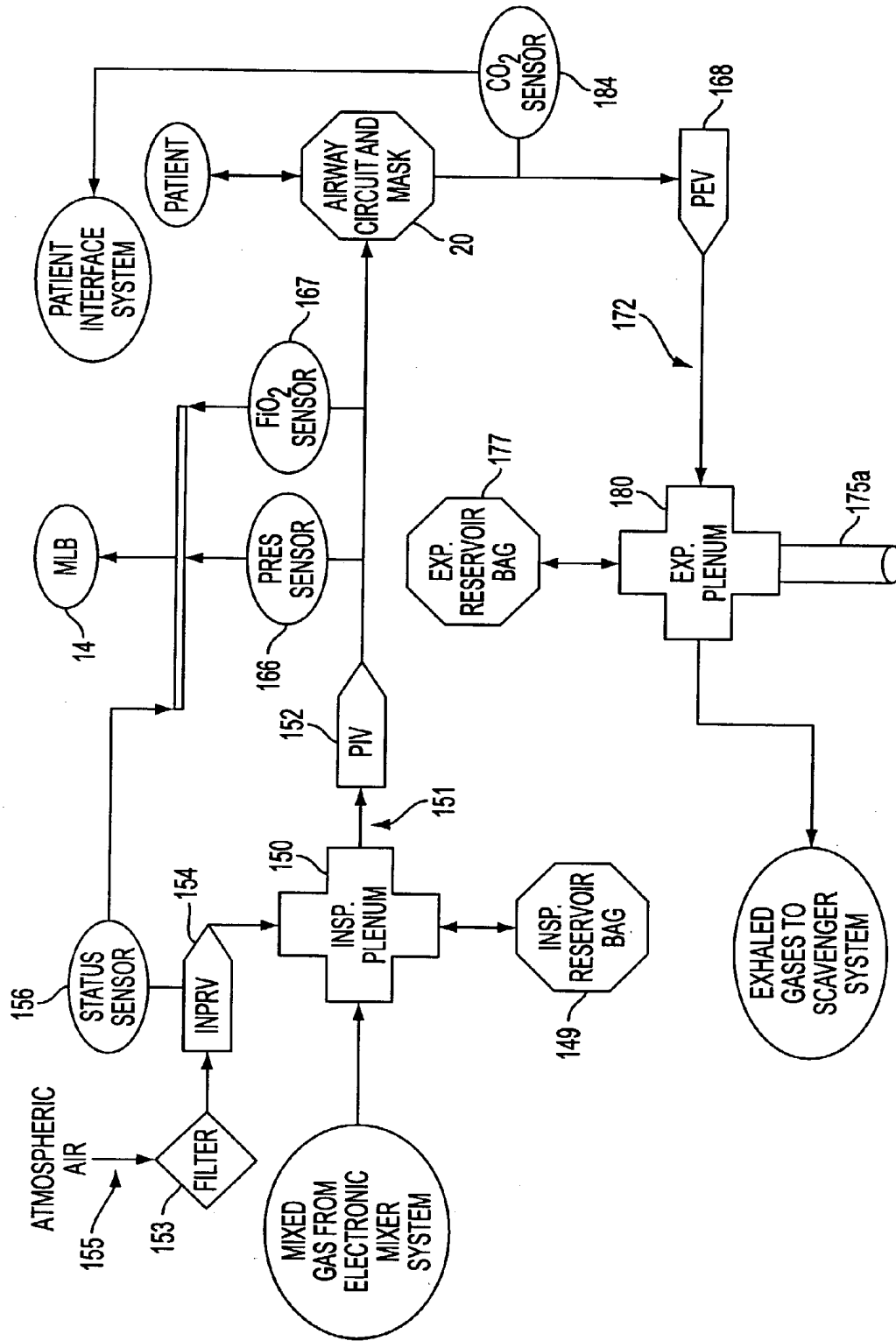

FIG. 9B

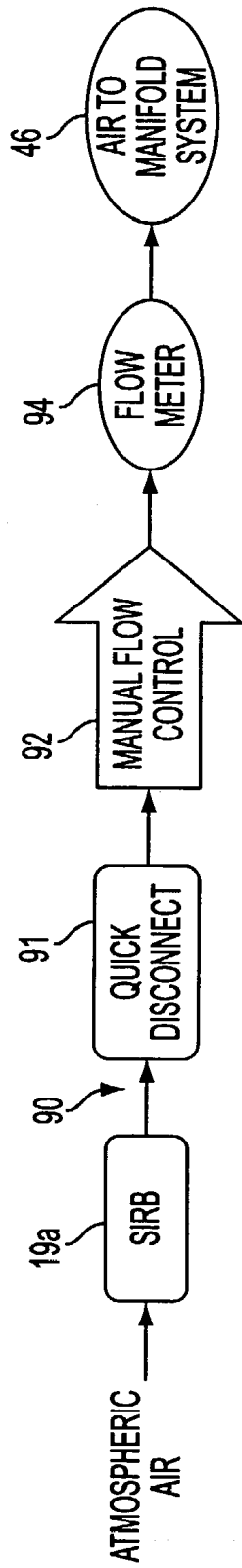

FIG. 10A

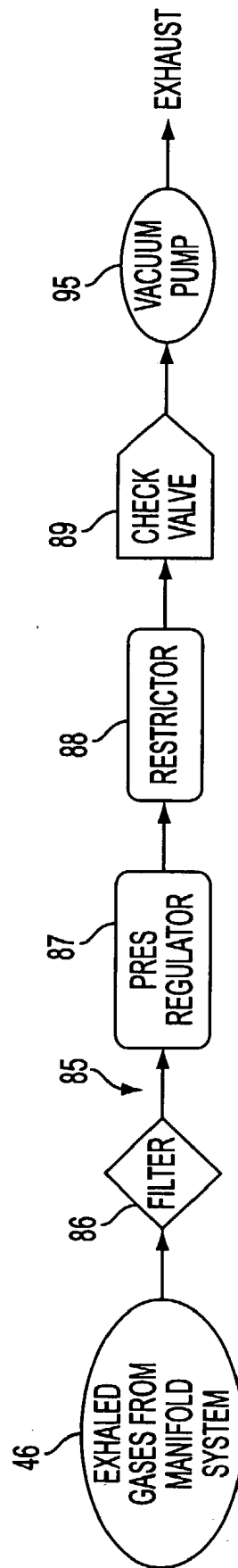

FIG. 10B

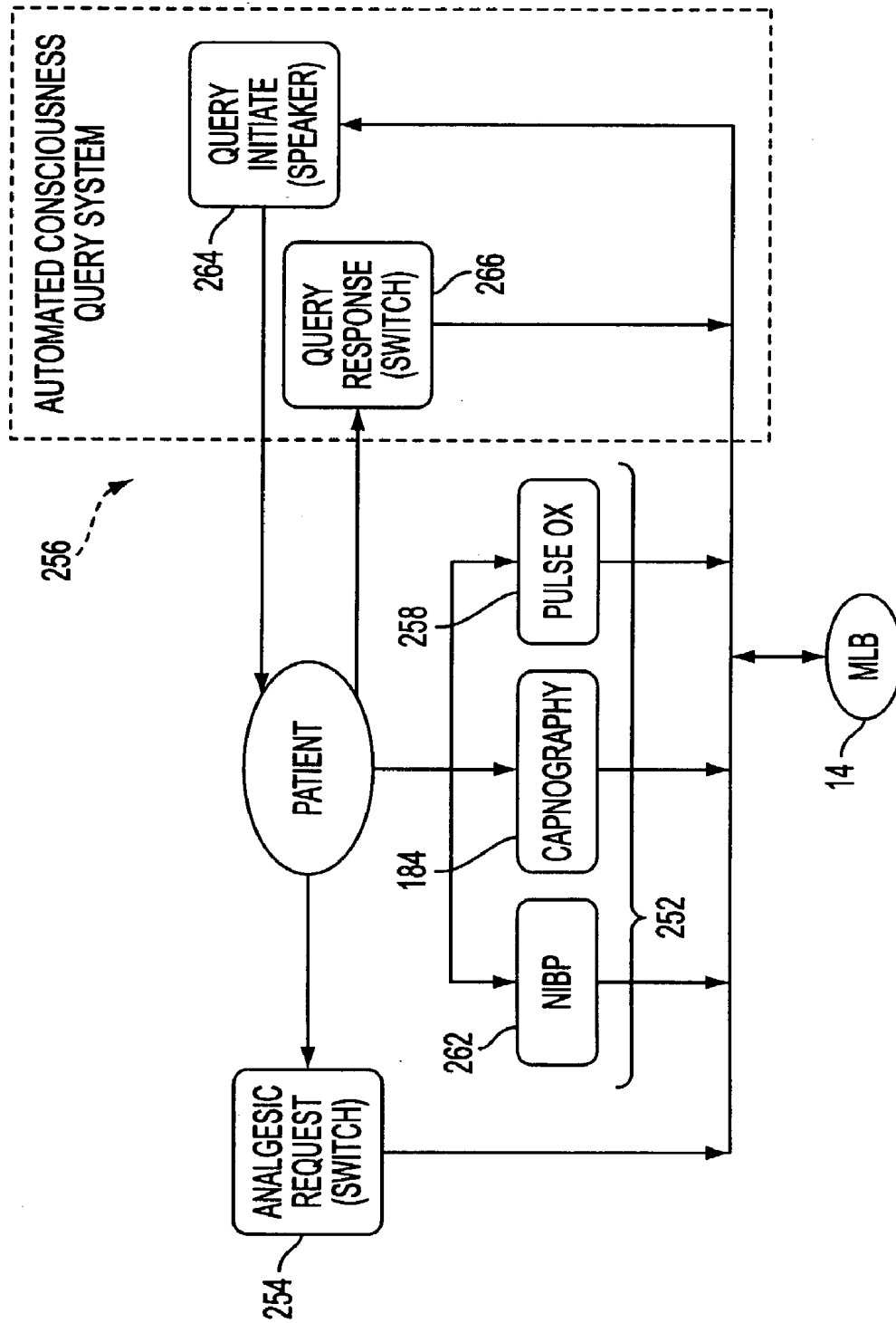

FIG. 11

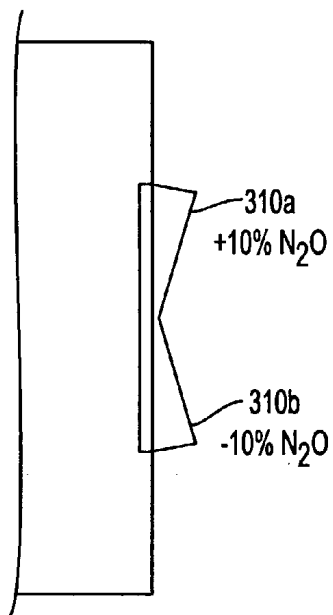
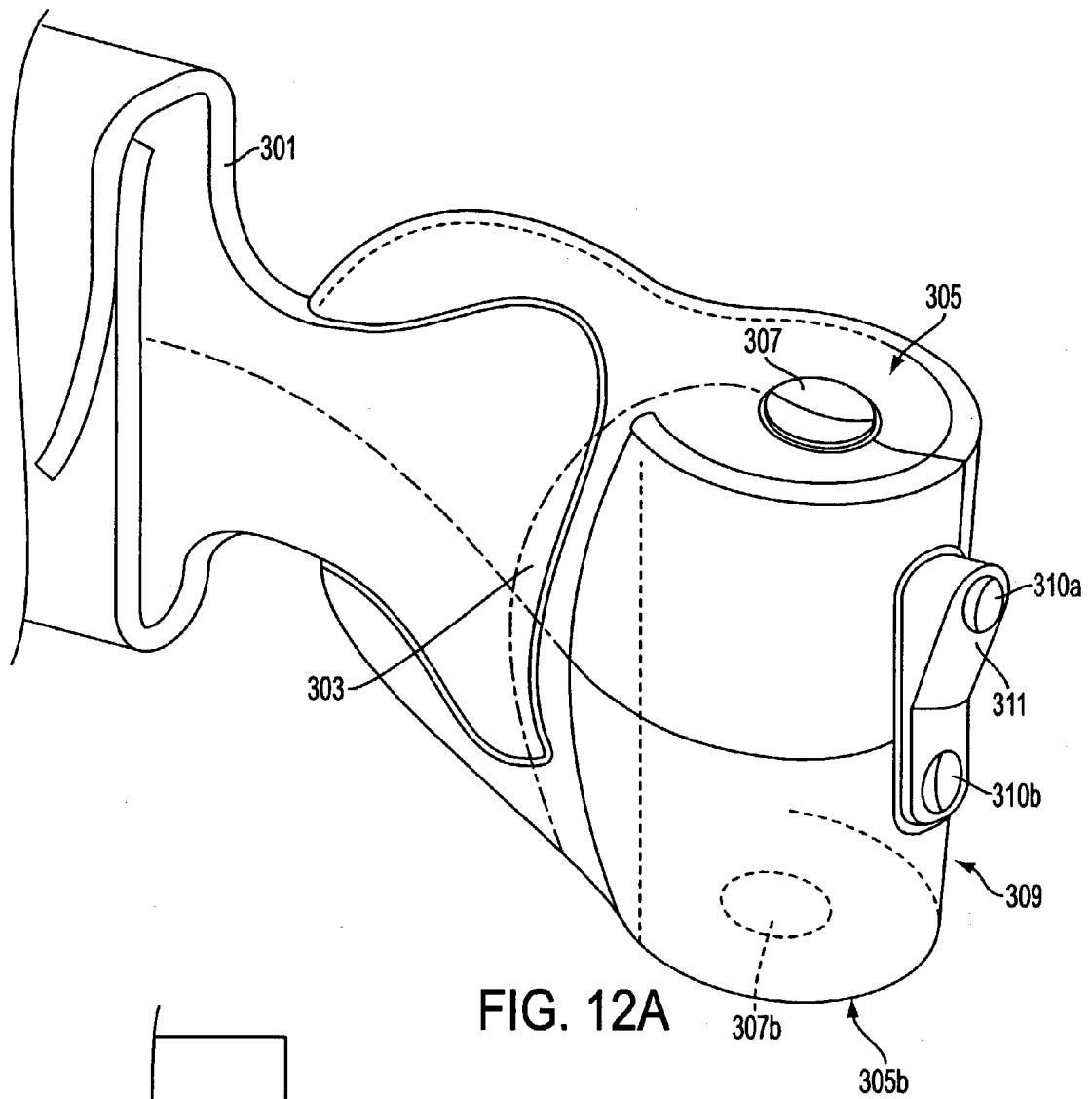

FIG. 12B

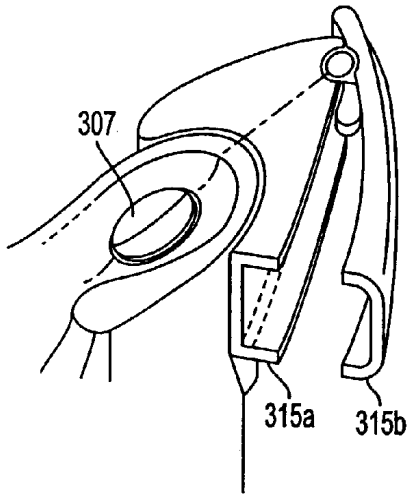

FIG. 13B

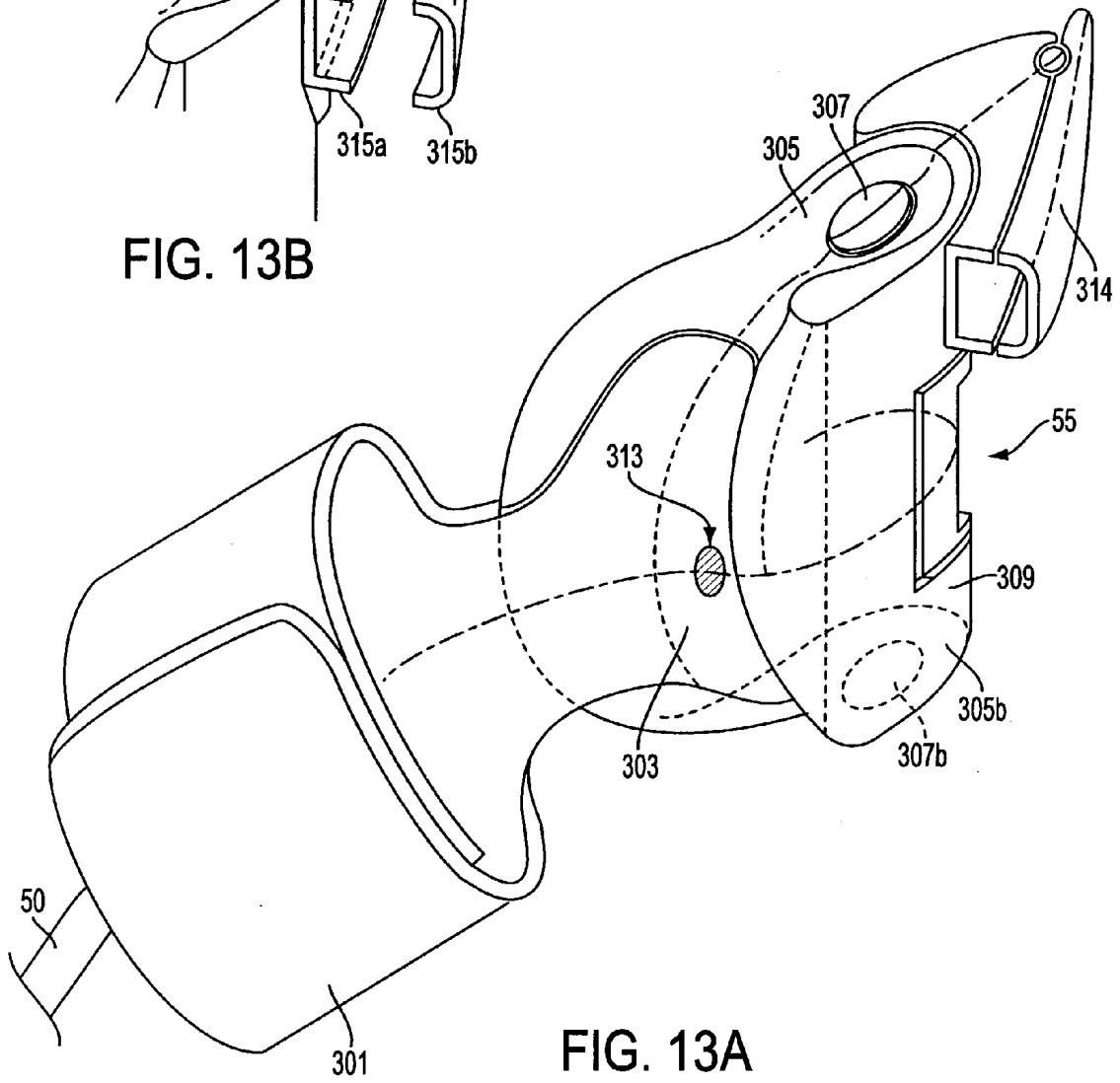

FIG. 13A

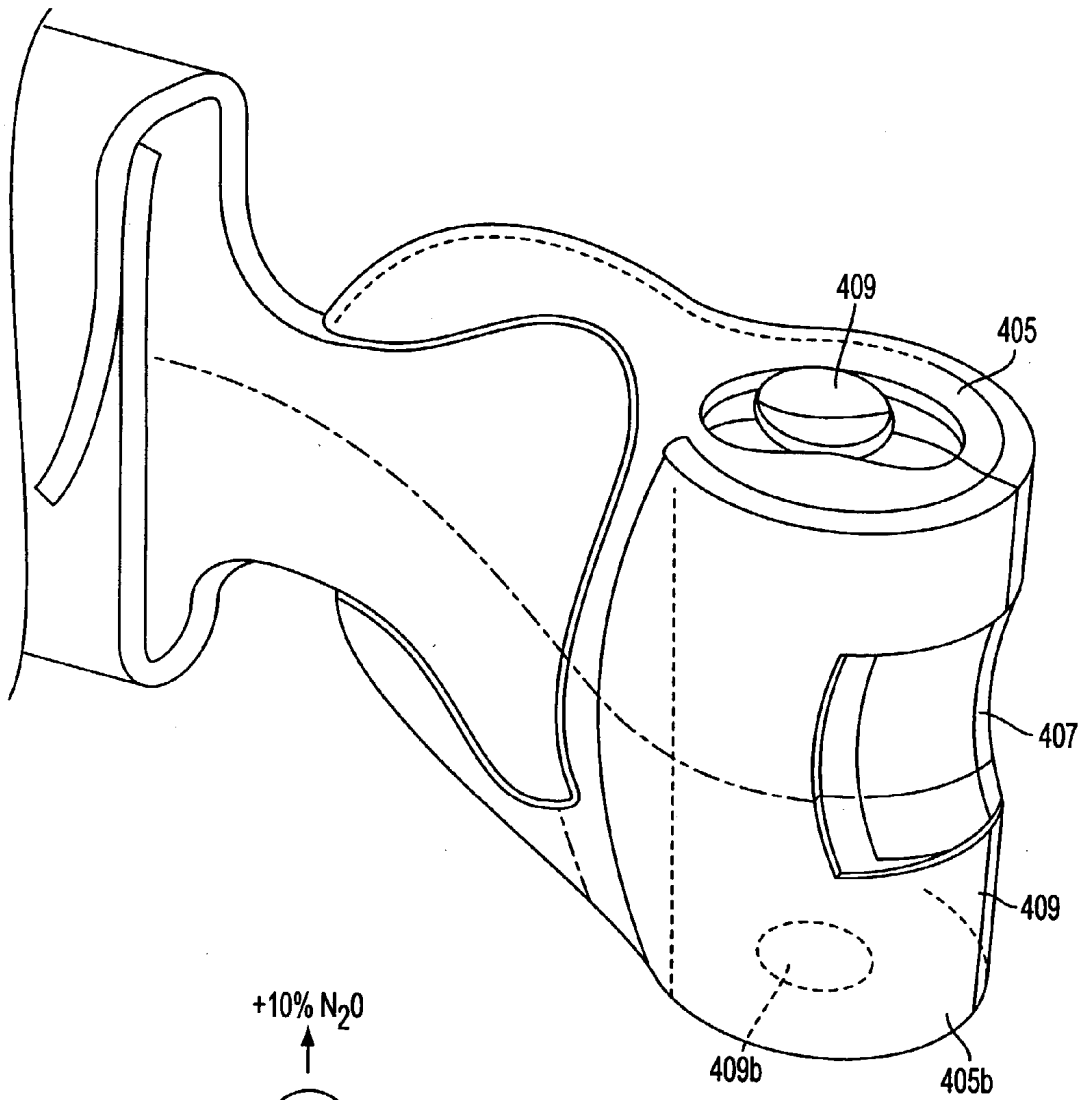

FIG. 14A

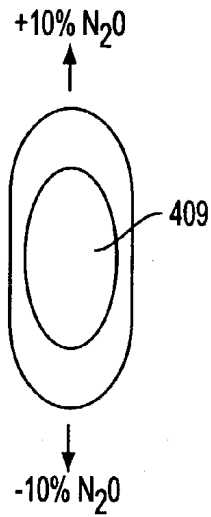

FIG. 14B

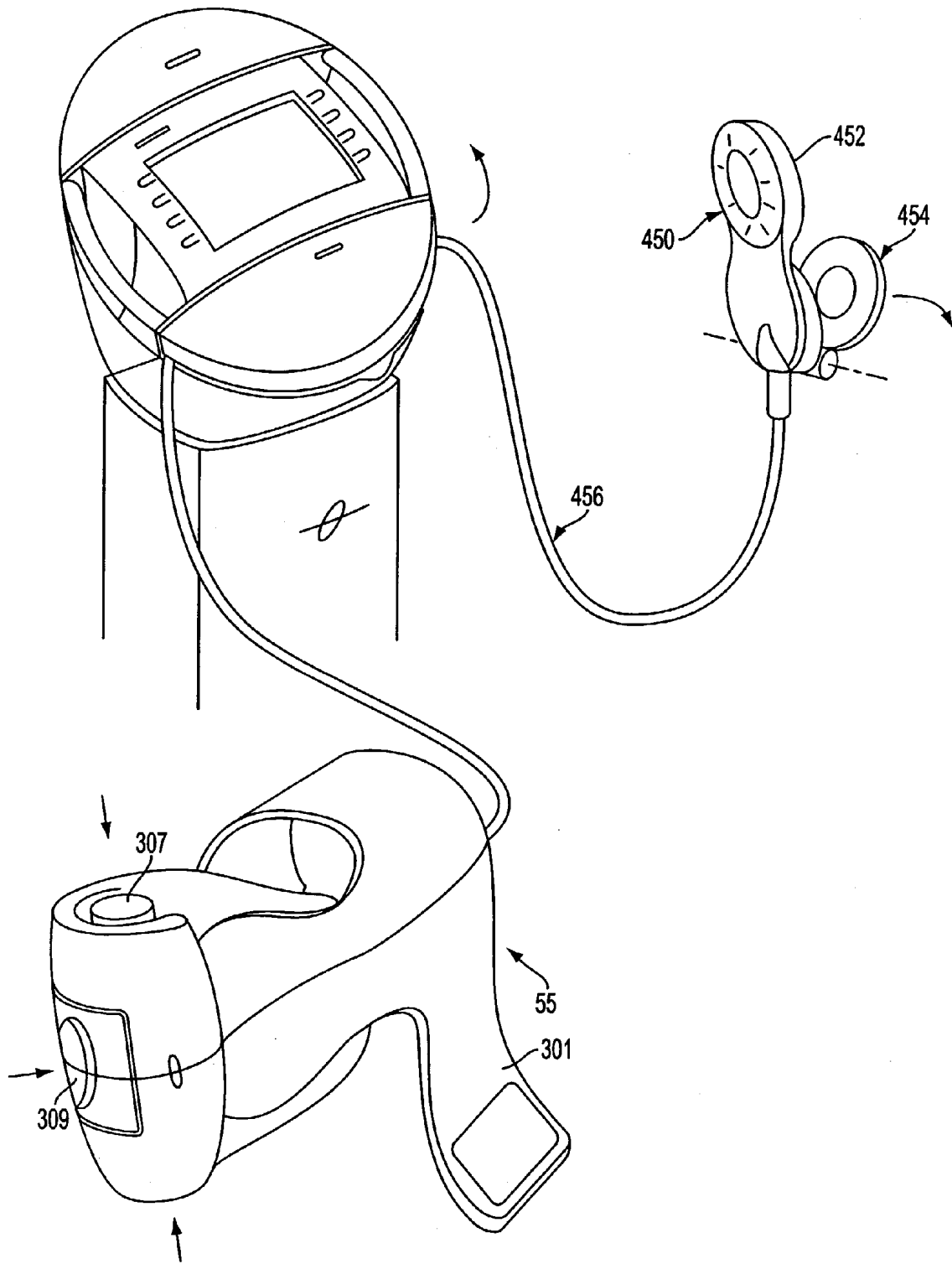

FIG. 15

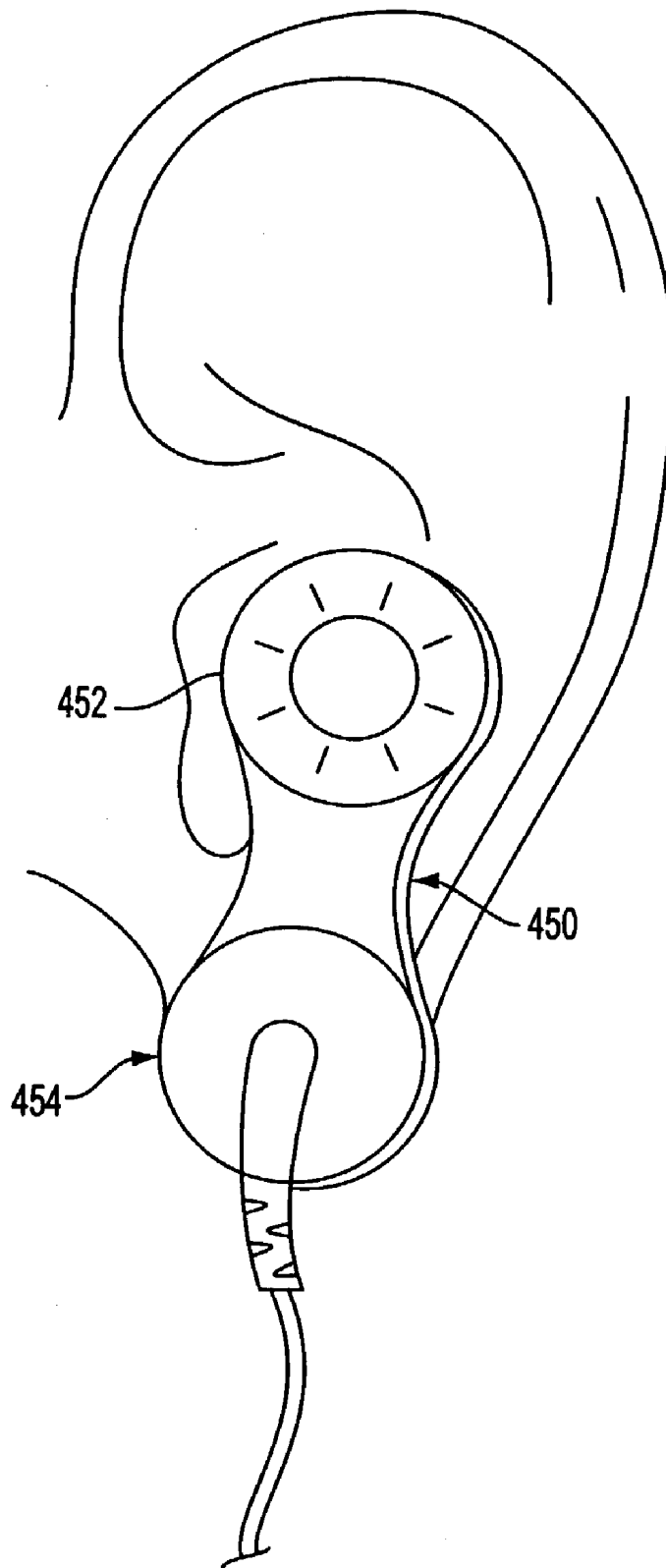

FIG. 16

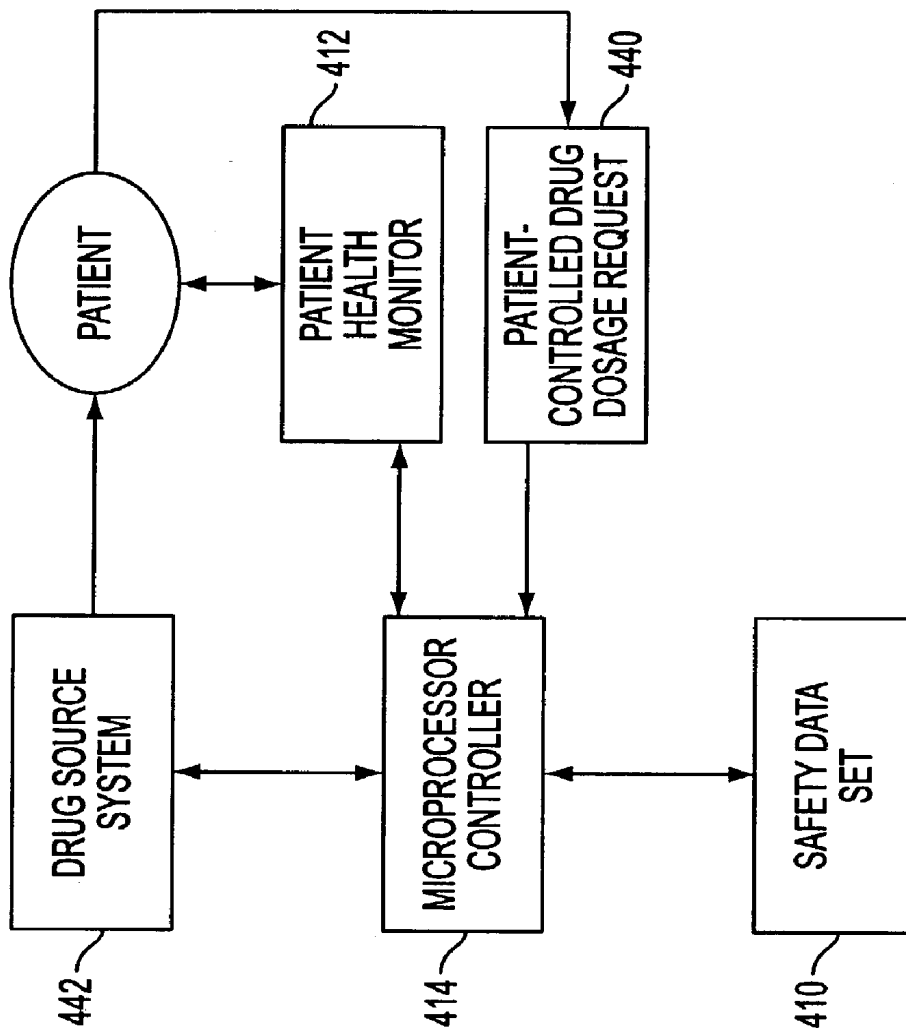

FIG. 17

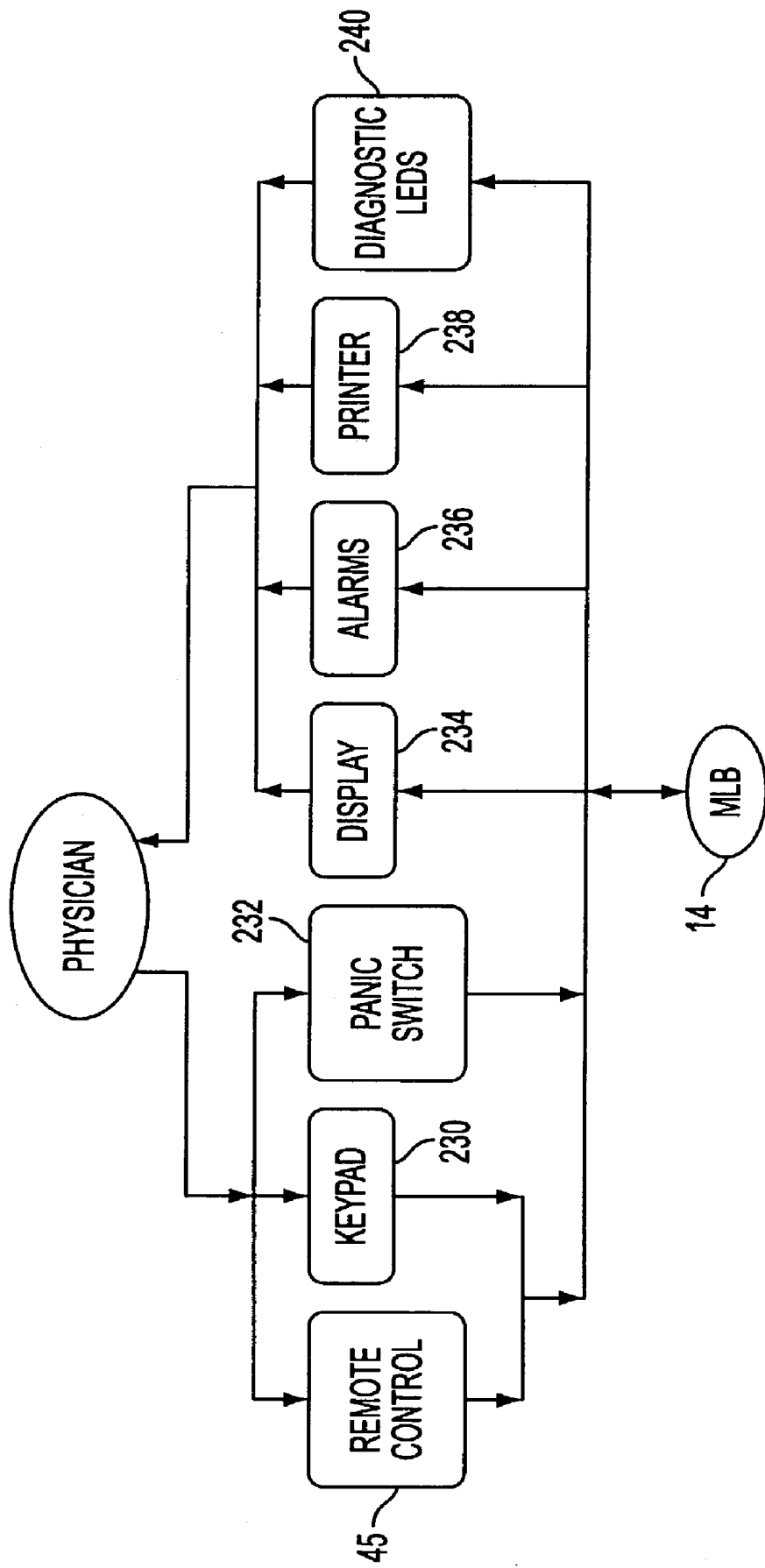

FIG. 18

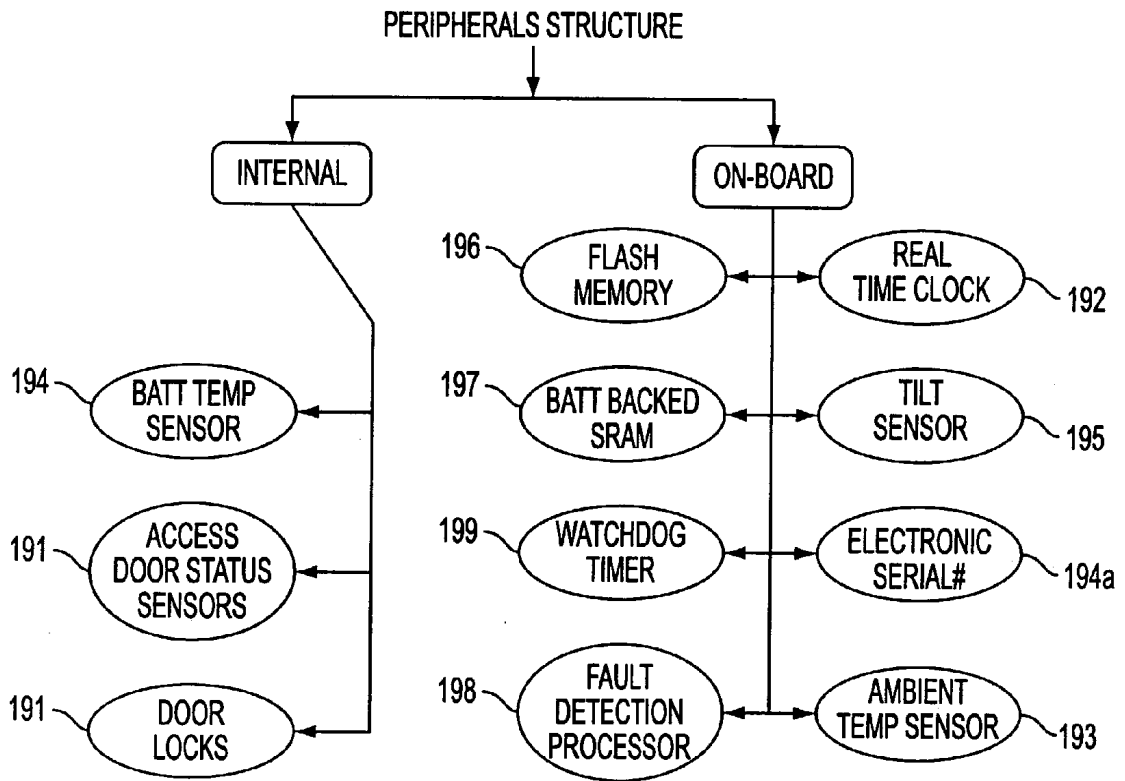

FIG. 19A

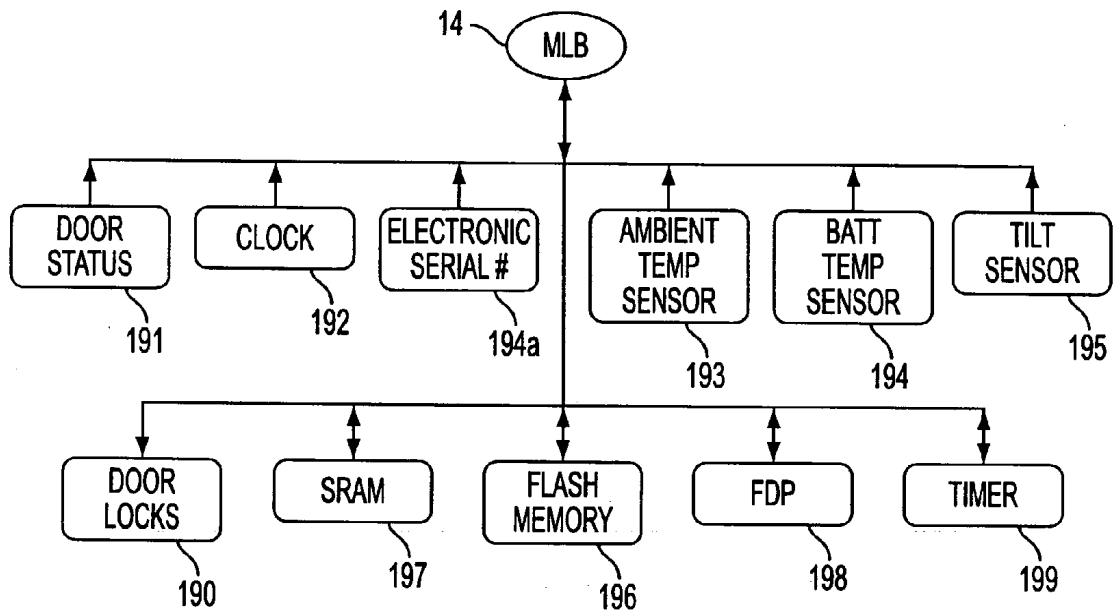

FIG. 19B

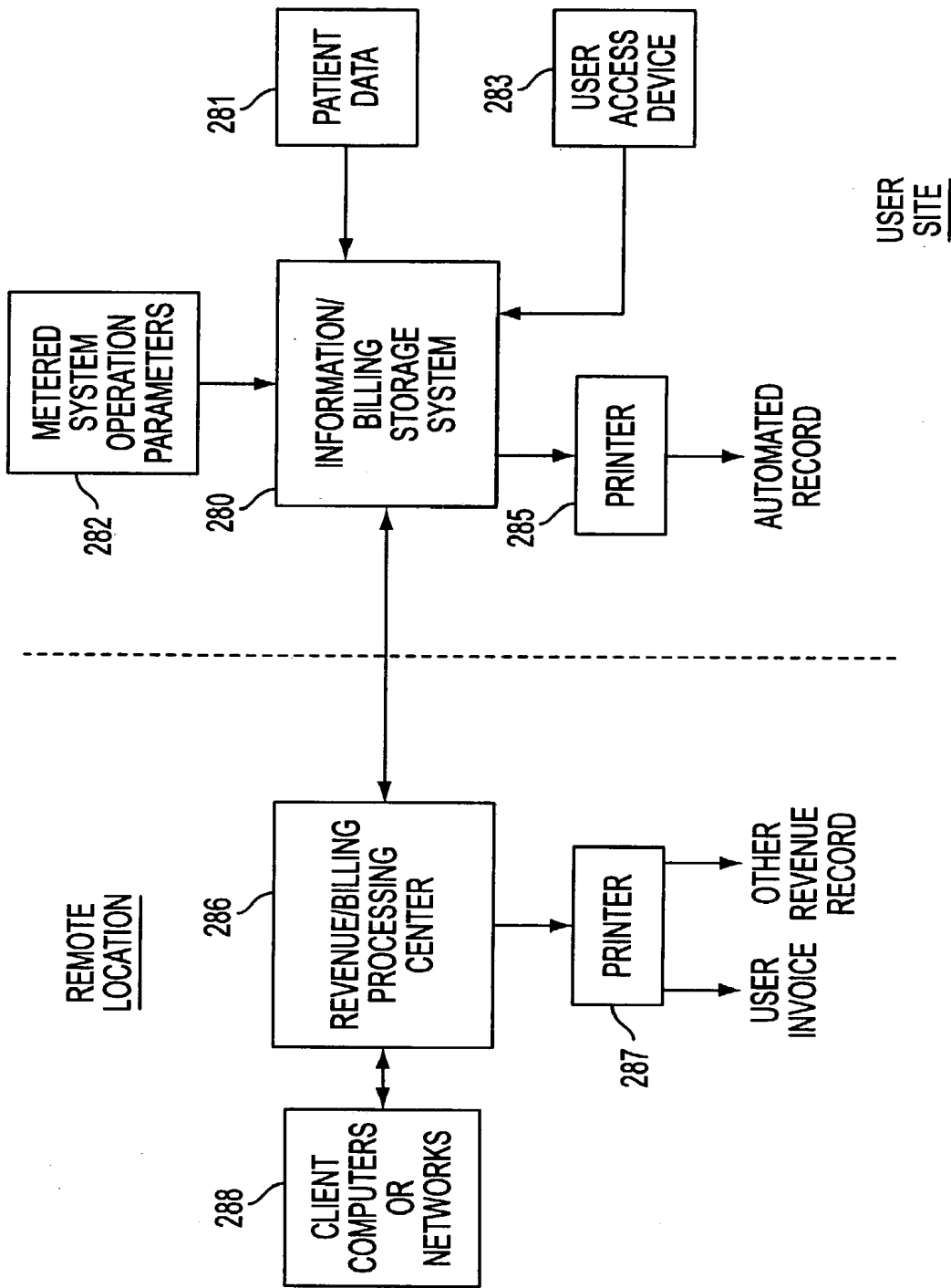

FIG. 20

| PATIENT MONITOR           | MONITOR READING   | ACTION  |
|---------------------------|---|---|
| O <sub>2</sub> SATURATION | ≥ 90%   | NONE  |
|                           | < 90%, ≥ 85%  | ALARM 1 SOUNDS FOR 15 S. IF SILENCED MANUALLY, NO FURTHER ACTION IF NOT SILENCED, N <sub>2</sub> O IS REDUCED TO THE LESSER CONCENTRATION OF 45% OR CURRENT CONCENTRATION - 10%. SIMILAR ALGORITHMS FOR SEVOFLURANE AND IV INFUSIONS TO BE SPECIFIED. |
|                           | < 85%, ≥ 80%  | ALARM 2 SOUNDS, N <sub>2</sub> O REDUCED TO THE LESSER CONCENTRATION OF 45% OR CURRENT CONCENTRATION - 10% IMMEDIATELY  |
|                           | < 80%   | ALARM 3 SOUNDS, N <sub>2</sub> O REDUCED TO 0%  |
| PULSE RATE                | ≥ 45/min.   | NONE  |
|                           | < 45/min., ≥ 35/min.  | ALARM 1 SOUNDS FOR 15 S. IF SILENCED MANUALLY, NO FURTHER ACTION. IF NOT SILENCED, N <sub>2</sub> O IS REDUCED TO THE LESSER CONCENTRATION OF 45% OR CURRENT CONCENTRATION - 10%  |
|                           | < 35/min.   | ALARM 3 SOUNDS, N <sub>2</sub> O REDUCED TO 0%  |
| CO <sub>2</sub> MAXIMUM   | ≤ 50 mm Hg  | NONE  |
|                           | > 50 mm Hg, ≤ 55 mm Hg                                      | ALARM 1 SOUNDS FOR 15 S. IF SILENCED MANUALLY, NO FURTHER ACTION. IF NOT SILENCED, N <sub>2</sub> O IS REDUCED TO THE LESSER CONCENTRATION OF 45% OR CURRENT CONCENTRATION - 10%  |
|                           | > 55 mm Hg, ≤ 60 mm Hg                                      | ALARM 2 SOUNDS, N <sub>2</sub> O REDUCED TO THE LESSER CONCENTRATION OF 45% OR CURRENT CONCENTRATION - 10% IMMEDIATELY  |
|                           | < 60 mm Hg  | ALARM 3 SOUNDS, N <sub>2</sub> O REDUCED TO 0%  |
| RESPIRATION RATE          | APNEA < 1 min.  | NONE  |
|                           | APNEA ≥ 1 min.  | ALARM 2 SOUNDS, N <sub>2</sub> O REDUCED TO THE LESSER CONCENTRATION OF 45% OR CURRENT CONCENTRATION - 10% IMMEDIATELY  |
|                           | ALARM 2 AND APNEA ≥ 30 s.                                   | ALARM 3 SOUNDS, N <sub>2</sub> O REDUCED TO 0%  |
| SYSTOLIC BP               | > 70 mm Hg  | NONE  |
|                           | ≤ 70 mm Hg, > 65 mm Hg                                      | ALARM 1 SOUNDS FOR 15 S. IF SILENCED MANUALLY, NO FURTHER ACTION. IF NOT SILENCED, N <sub>2</sub> O IS REDUCED TO THE LESSER CONCENTRATION OF 45% OR CURRENT CONCENTRATION - 10%  |
|                           | ≤ 65 mm Hg, > 60 mm Hg                                      | ALARM 2 SOUNDS, N <sub>2</sub> O REDUCED TO THE LESSER CONCENTRATION OF 45% OR CURRENT CONCENTRATION - 10% IMMEDIATELY  |
|                           | ≤ 60 mm Hg  | ALARM 3 SOUNDS, N <sub>2</sub> O REDUCED TO 0%  |
| CONSCIOUSNESS MONITOR     | PATIENT RESPONDS  | NONE  |
|                           | PATIENT DOES NOT RESPOND                                    | ALARM 1 SOUNDS FOR 15 S. IF SILENCED MANUALLY, NO FURTHER ACTION. IF NOT SILENCED, N <sub>2</sub> O IS REDUCED TO THE LESSER CONCENTRATION OF 45% OR CURRENT CONCENTRATION - 10%  |
|                           | ALARM 1 AND PATIENT DOES NOT RESPOND TO STIMULUS 30 s LATER | ALARM 2 SOUNDS, N <sub>2</sub> O REDUCED TO THE LESSER CONCENTRATION OF 45% OR CURRENT CONCENTRATION - 10% IMMEDIATELY  |
|                           | ALARM 2 AND PATIENT DOES NOT RESPOND TO STIMULUS 30 s LATER | ALARM 3 SOUNDS, N <sub>2</sub> O REDUCED TO 0%  |

FIG. 21A

| MONITOR                               | UNIT         | TRANSITION REQUIREMENT     | > SETPOINT   | < SETPOINT   | VALUE  |
|---------------------------------------|--------------|----------------------------|--------------|--|--|
| O <sub>2</sub> TANK PRESSURE          | PSI          | LOW TANK PRESSURE          | > SETPOINT   | < SETPOINT   | N/A  |
| O <sub>2</sub> INTERRUPTION FAIL-SAFE | LOGICAL      | O <sub>2</sub> INTERRUPTED | FALSE        | N/A  | TRUE   |
| TOTAL GAS FLOW                        | LITERS / MIN | LOW GAS FLOW               | > SETPOINT   | < SETPOINT   | N/A  |
| N <sub>2</sub> O TANK PRESSURE        | PSI          | LOW TANK PRESSURE          | > SETPOINT   | < SETPOINT   | N/A  |
| FI <sub>O2</sub>                      | %            | LOW FI <sub>O2</sub>       | >= 30        | N/A  | < 30   |
| VACUUM PUMP                           | LOGICAL      | INSUFFICIENT VACUUM PUMP   | OK           | FAIL   | N/A  |
| POWER                                 | LOGICAL      | INTERRUPTION IN POWER      | OK           | N/A  | FAIL   |
|                                       |              | NORMAL                     | NO CHANGE    | START ALARM 1  | START ALARM 2<br>REDUCE N <sub>2</sub> O TO 0% |
|                                       |              | ALARM 1                    | NORMAL       | ALARM 1  | ALARM 2  |
|                                       |              |                            | STOP ALARM 1 | IF DURATION > 15 SEC AND NOT SILENCED THEN REDUCE N <sub>2</sub> O TO 45% OR CURRENT - 10% | START ALARM 2<br>REDUCE N <sub>2</sub> O TO 0% |
|                                       |              | ALARM 2                    | NORMAL       | ALARM 1  | ALARM 2  |
|                                       |              |                            | STOP ALARM 2 | GO TO ALARM 1  | NO CHANGE                                      |
|                                       |              |                            | NORMAL       | ALARM 1  | ALARM 2  |

FIG. 21B

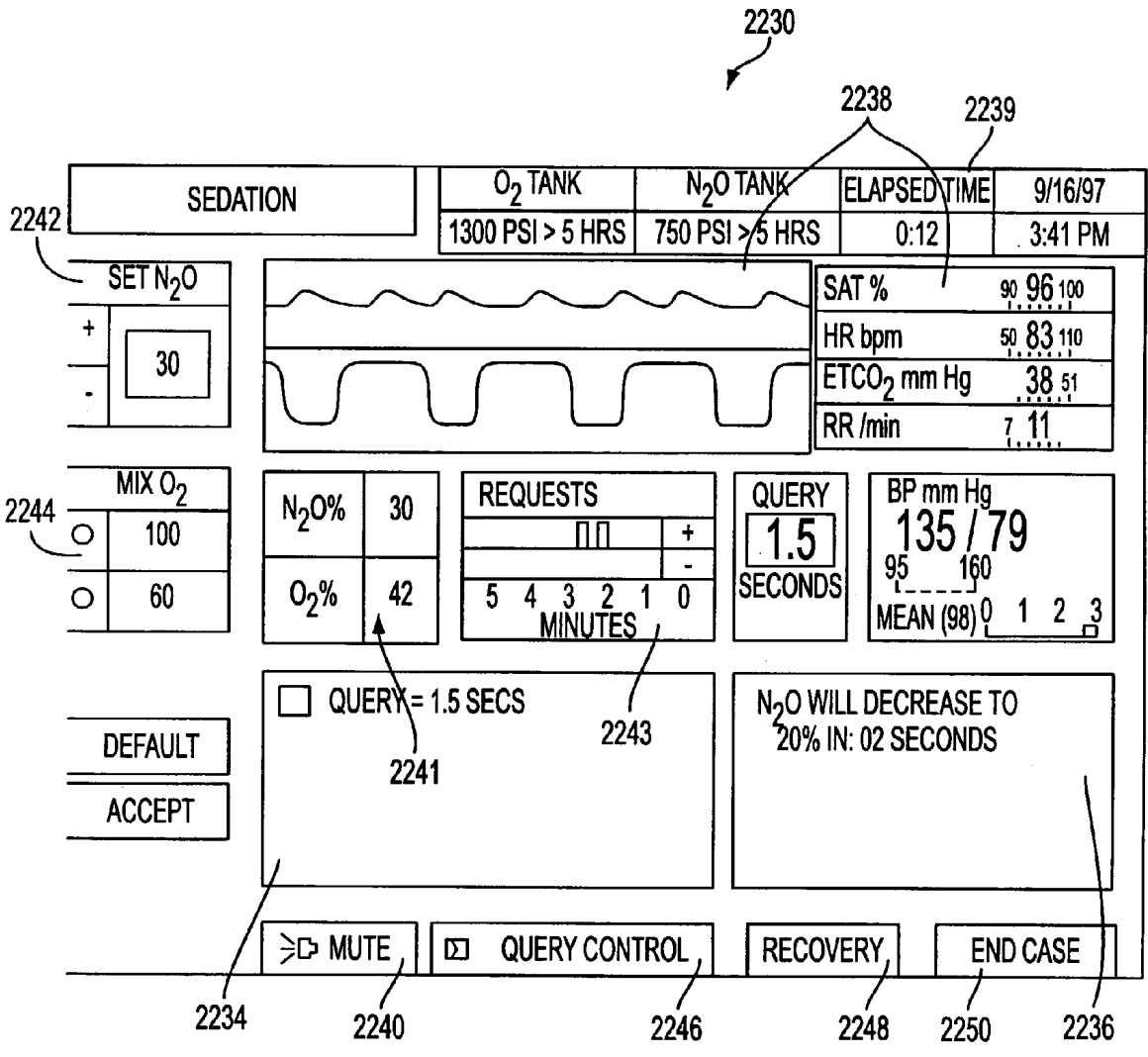

FIG. 22A

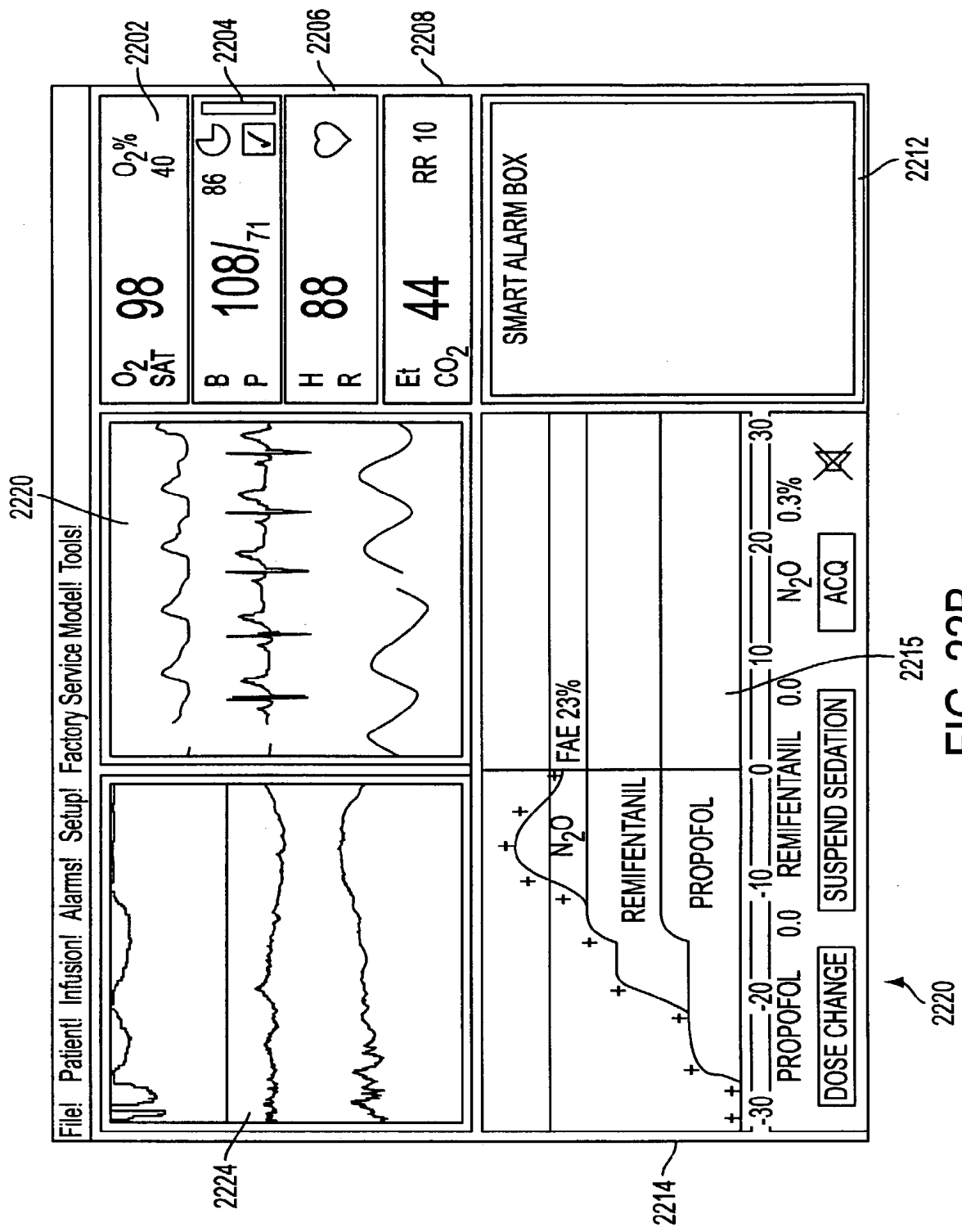

FIG. 22B

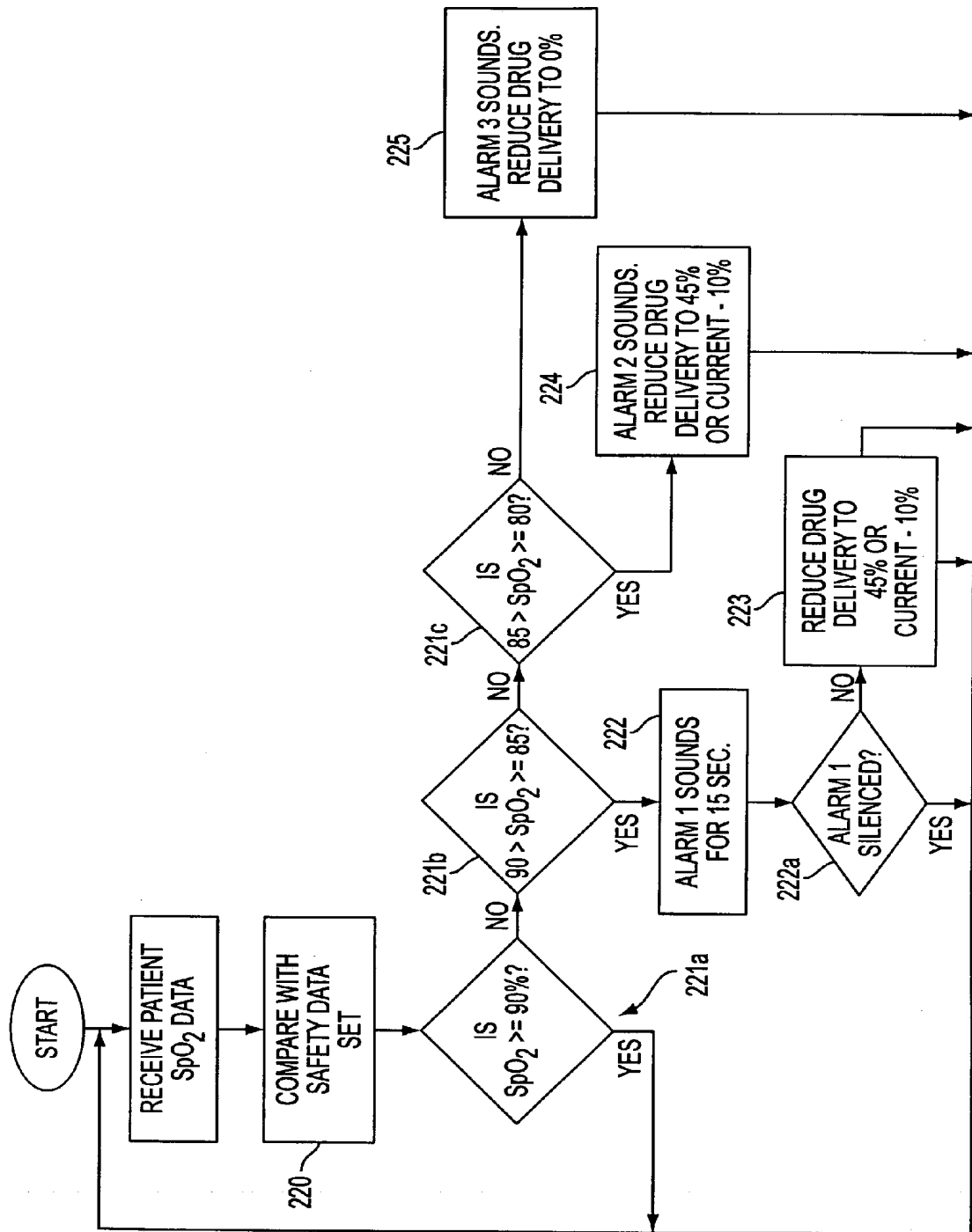

FIG. 23A

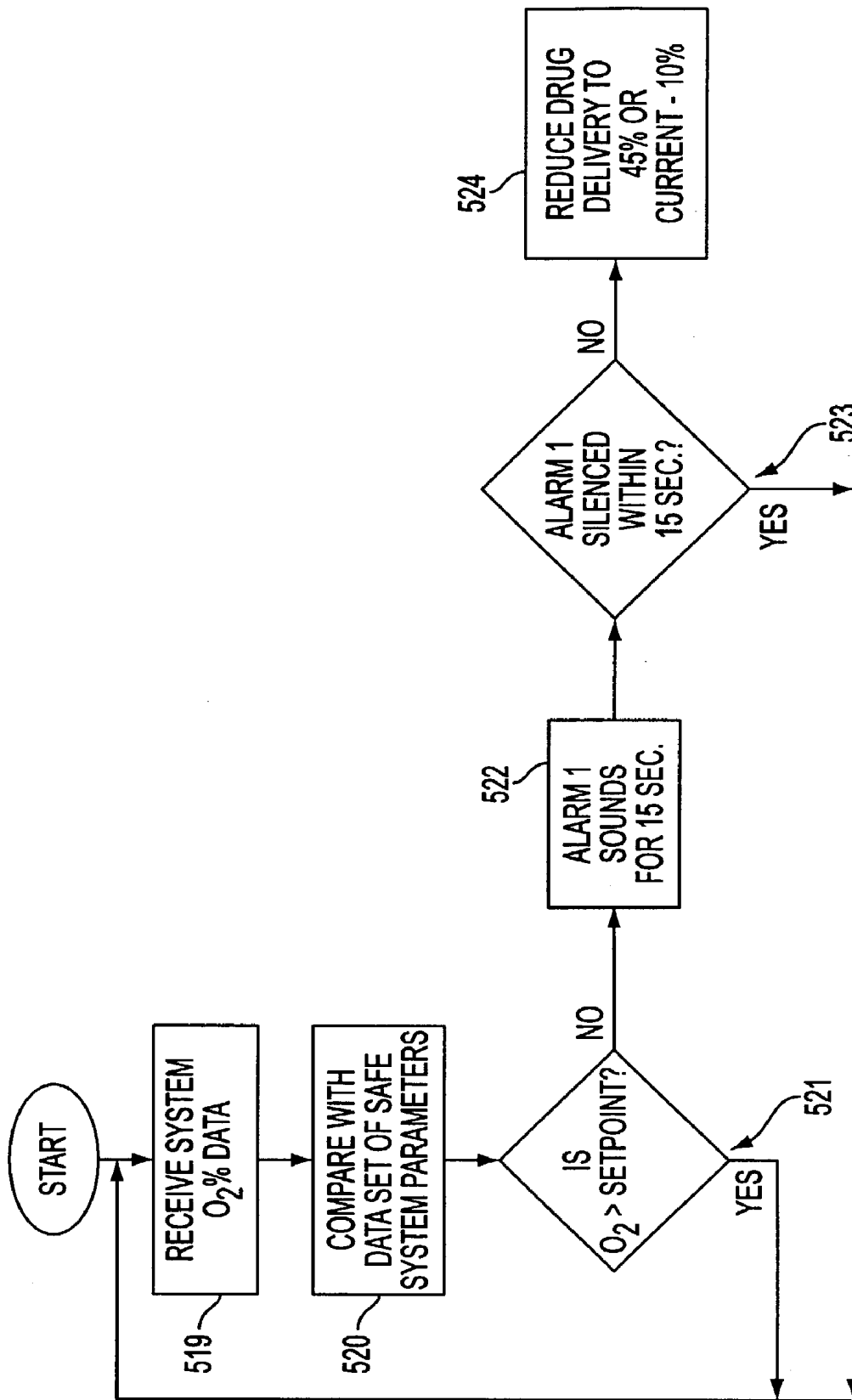

FIG. 23B

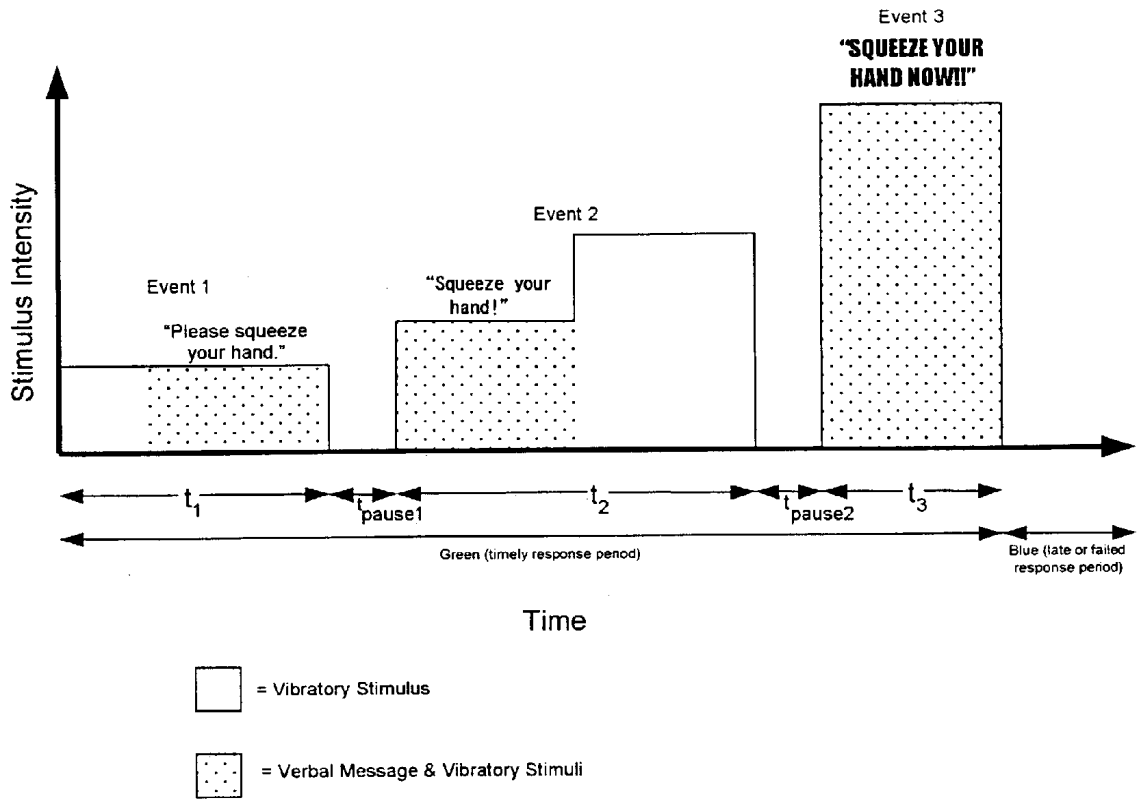

FIG. 24

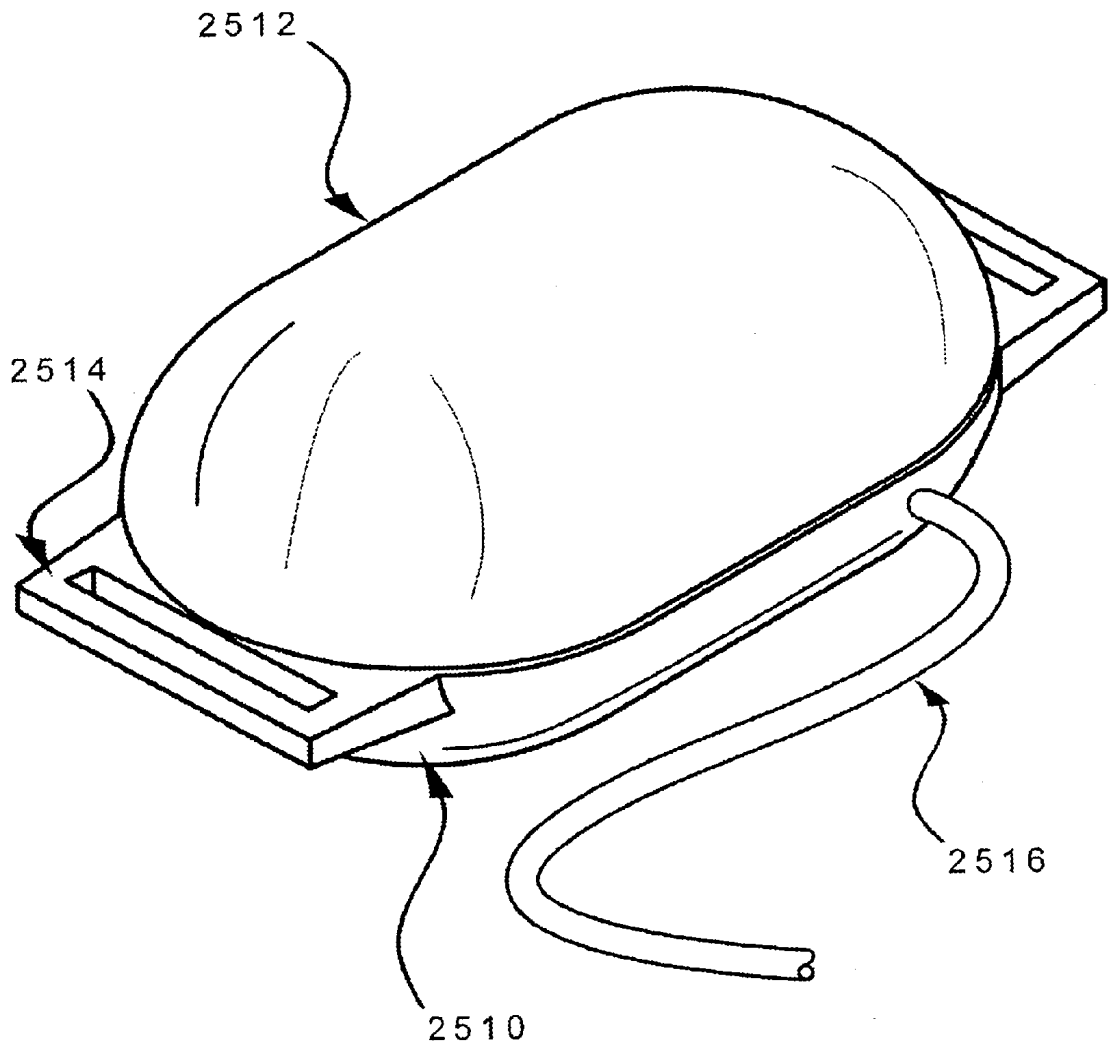

FIG. 25

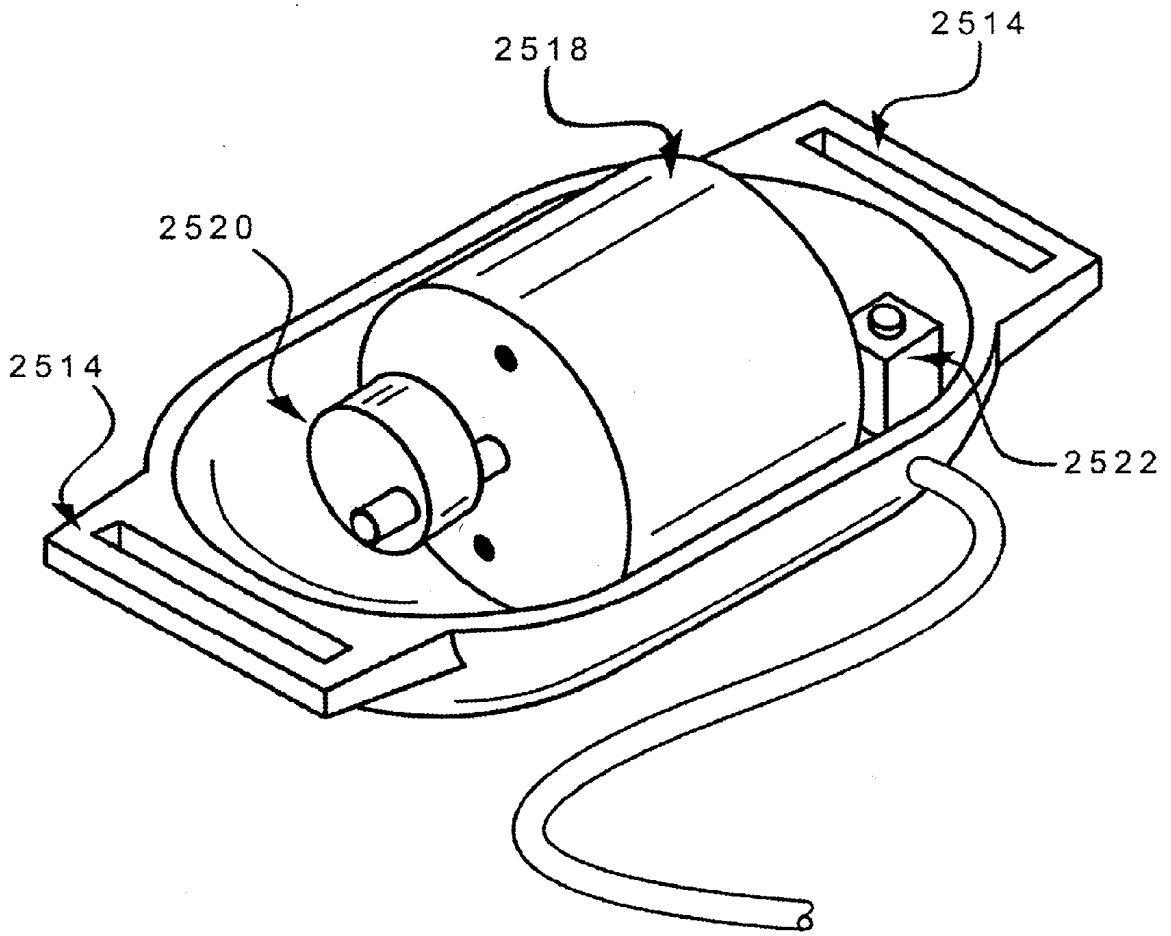

FIG. 26

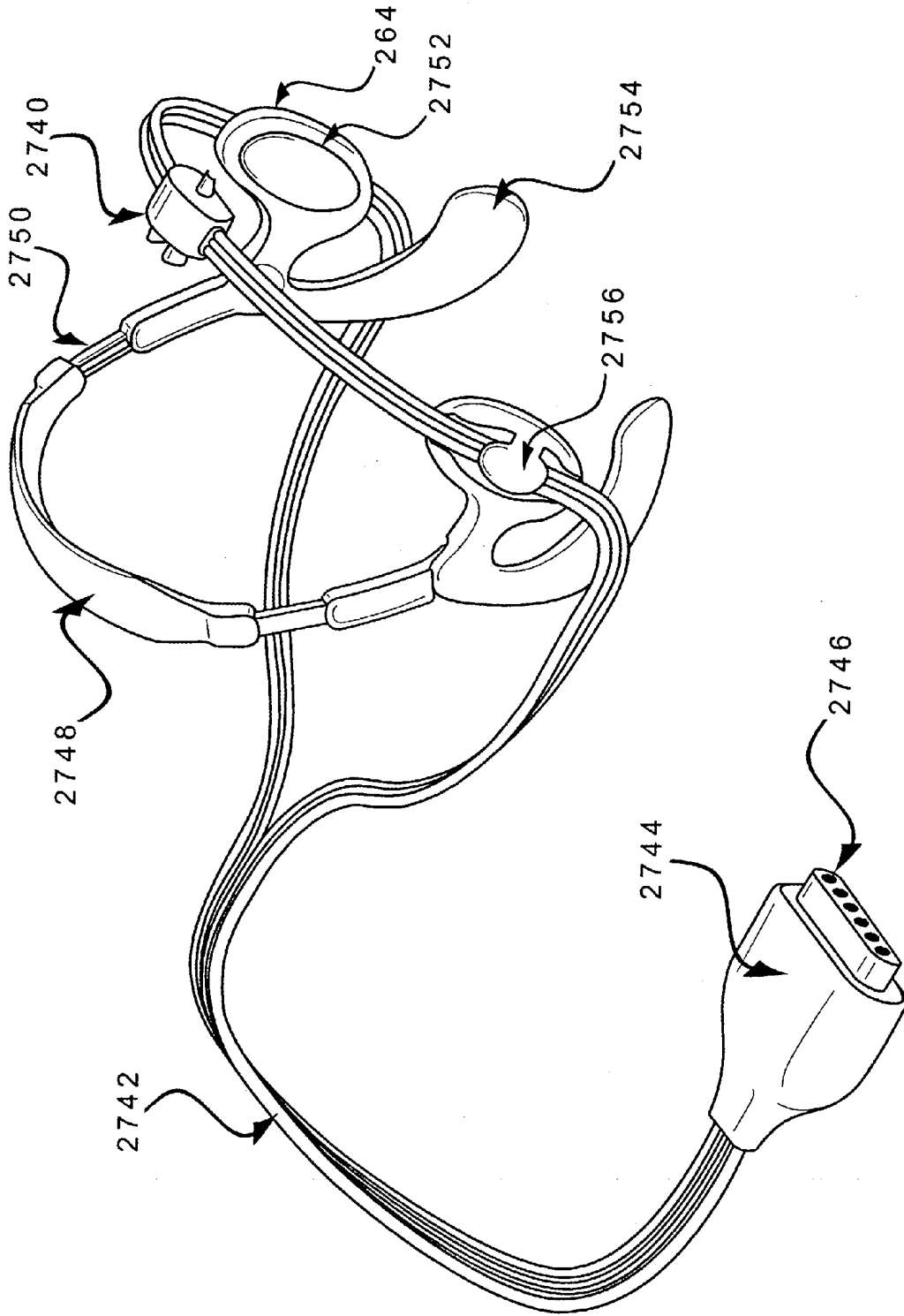

FIG. 27

**Automated Response Testing Set-up**

*ART Delivery Mode*

**Auto**  
Automated Delivery to Patient

**Prompt**  
Prompted Manual Check of Patient

*ART Interval (minutes)*

**1**   **2**   **3**

*ART Language*

English ▼

**CANCEL**   **OK**

28200

FIG. 28

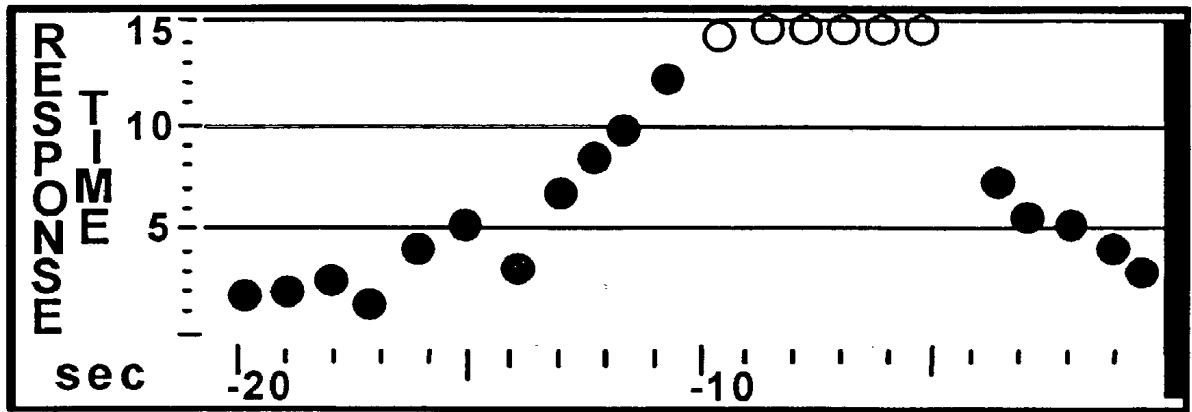

2878  
FIG. 29

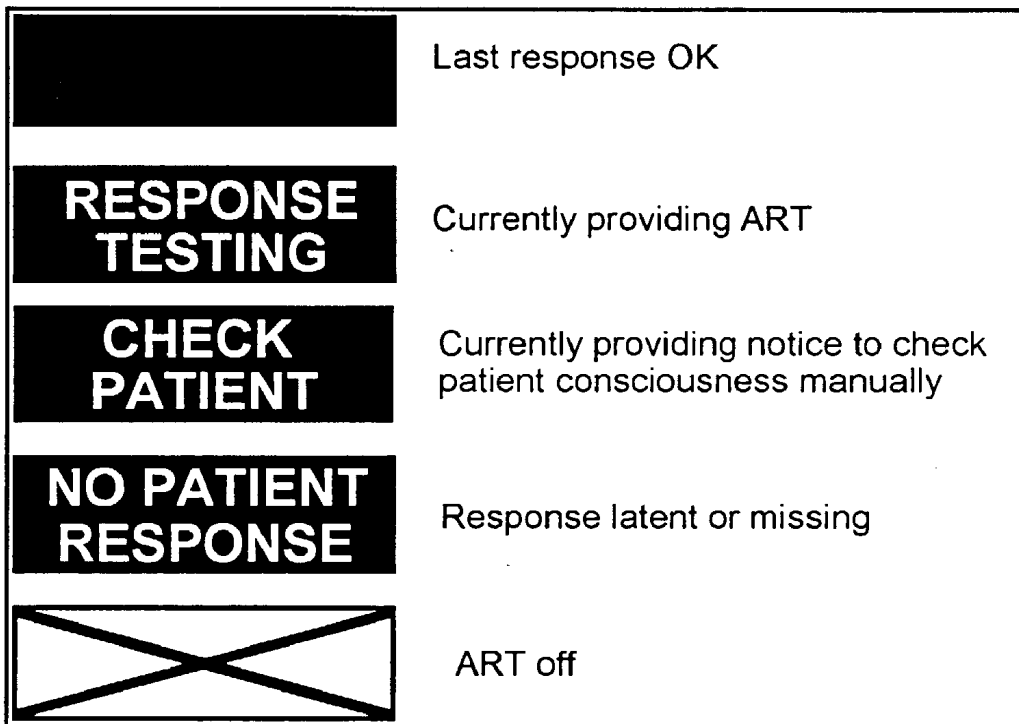

2880  
FIG. 30

## APPARATUSES AND METHODS FOR AUTOMATICALLY ASSESSING AND MONITORING A PATIENT'S RESPONSIVENESS

### CROSS-REFERENCE TO RELATED APPLICATIONS

[0001] The present application is a continuation-in-part of U.S. patent application Ser. No. 09/324,759, filed Jun. 3, 1999 which claims priority from U.S. Provisional Patent Application Serial No. 60/087,841 filed Jun. 3, 1998, and is incorporated herein by reference. The present application also claims priority under 35 U.S.C. §119(e) from U.S. Provisional Patent Application Serial No. 60/342,773 filed Dec. 28, 2001 and incorporated herein by reference.

### FIELD OF THE INVENTION

[0002] This invention relates generally to an apparatus and method for relieving patient pain and/or anxiety. More particularly, this invention relates to a system and method for providing sedation, analgesia and/or amnesia to a conscious patient undergoing a painful or anxiety-producing medical or surgical procedure, or suffering from post-procedural or other pain or discomfort. The invention electronically integrates through conservative software management the delivery of one or more sedative, analgesic or amnestic drugs with the electronic monitoring of one or more patient physiological conditions. In one form, the invention includes the use of one or more sets of stored data-defining parameters reflecting patient and system states, the parameters being accessed through software to conservatively manage and correlate drug delivery to safe, cost effective, optimized values related to the conscious patient's vital signs and other physiological conditions.

### BACKGROUND OF THE INVENTION

[0003] This invention is directed to providing a conscious patient who is undergoing a painful, uncomfortable or otherwise frightening (anxiety-inspiring) medical or surgical procedure, or who is suffering from post-procedural or other pain or discomfort, with safe, effective and cost-effective relief from such pain and/or anxiety. Focuses of the invention include, but are not limited to, enabling the provision of sedation (inducement of a state of calm), analgesia (insensitivity to pain) and/or amnesia to a conscious patient (sometimes referred to collectively as "conscious sedation") by a nonanesthetist practitioner, i.e., a physician or other clinician who is not an anesthesiologist (M.D.A.) or certified nurse anesthetist (C.R.N.A.), in a manner that is safe, effective and cost-effective; the provision of same to patients in ambulatory settings such as hospital laboratories, ambulatory surgical centers, and physician's offices; and the provision of patient post-operative or other pain relief in remote medical care locations or in home care environments. To those ends, the invention mechanically integrates through physical proximity and incorporation into an overall structural system and electronically integrates through conservative, decision-making software management, the delivery of one or more sedative, analgesic or amnestic drugs to the patient with the electronic monitoring of one or more patient physiological conditions.

[0004] In traditional operating rooms, anesthesiologists provide patients relief from pain, fear and physiological

stress by providing general anesthesia. "Anesthesia" is typically used (and is so used herein) interchangeably with the state of "unconsciousness." Over a billion painful and anxiety-inspiring medical and surgical procedures, however, are performed worldwide each year without anesthesia. Thus, outside the practice of anesthesiology there are currently a large number of patients who, while conscious, undergo medical or surgical procedures that produce considerable pain, profound anxiety, and/or physiological stress. Such medical or surgical procedures are often performed by procedural physicians (nonanesthetists) in hospital laboratories, in physicians' offices, and in ambulatory surgical centers. For example, physician specialists perform painful procedures on conscious patients such as pacemaker placement, colonoscopies, various radiological procedures, microlaparoscopy, fracture reduction, wound dressing changes in burn units, and central and arterial catheter insertion in pediatric patients, in hospital laboratory settings. Primary care physicians perform such procedures as flexible sigmoidoscopies, laceration repairs, bone marrow biopsies and other procedures in physicians' offices. Many surgical specialists perform painful procedures such as anterior segment repairs by ophthalmologists, plastic procedures by cosmetic surgeons, foreign body removal, transurethral procedures, incisions of neck and axilla nodes, and breast biopsies in their offices or in ambulatory surgical centers. The needs of patients for safe and effective pain and anxiety relief during and after such procedures are currently unmet.

[0005] Conscious sedation techniques currently available for use by procedural physicians (nonanesthetists) during medical or surgical procedures such as those described above include sedatives and opioids given orally, rectally or intra-muscularly; sedatives and analgesics administered intravenously; and local anesthetics. Often, however, such techniques are less than satisfactory.

[0006] In the case of oral, rectal or intramuscular administration of sedatives and opioids by procedural physicians during the provision of conscious sedation, there are currently no effective means available to assure that the effects of those drugs can be readily controlled to meet patient need. This is due in part to the variable interval between administration and the onset and dissipation of drug effect. Unreliable sedation and analgesia can result because of mismatches between the dosage administered and the patient's needs which can vary depending on the condition of the patient and the type of procedure performed. Such administration of sedation can also produce an unconscious patient at risk for developing airway obstruction, emesis with pulmonary aspiration or cardiovascular instability. To attempt to avoid these complications, procedural physicians often administer sedatives and analgesics sparingly. This may reduce the risk of major complications, but may also mean that few patients receive adequate relief from pain and/or anxiety during medical and surgical procedures outside the practice of anesthesiology.

[0007] The use of intravenous administration of sedatives and analgesics to conscious patients by procedural physicians in settings such as hospital laboratories, physicians' offices and other ambulatory settings is also less than satisfactory. With respect to intravenous bolus administration, plasma concentrations vary considerably when drugs are injected directly into the blood stream. This can result in initially excessive (potentially toxic) levels followed by

sub-therapeutic concentrations. Although intravenously administered drugs can be titrated to the patient's need, doing so safely and effectively usually requires the full-time attention of a trained care giver, e.g., an anesthesiologist. Costs and scheduling difficulties among other things typically preclude this option.

[0008] Due to the difficulties described above involving administration of sedatives and opioids, many procedural physicians rely on local anesthetics for pain relief. However, local anesthetics alone usually provide inadequate analgesia (insensitivity to pain) for most medical and surgical procedures and the injections themselves are often relatively painful.

[0009] In short, current methods commonly available to procedural physicians for providing effective pain relief to conscious patients outside the practice of anesthesiology typically fall short of the objective. There is not adequate training for such practitioners in the diagnosis and treatment of complications that may arise or result from the provision of sedation and analgesia to conscious patients. Procedures or mechanisms for ongoing quality management of the care of conscious patients undergoing painful and anxiety-inspiring medical or surgical procedures and the devices and methods employed in that care are inadequate.

[0010] An additional focus of this invention is the electronic monitoring of a conscious patient's physiological condition during drug delivery, and the electronic management of drug delivery by conservative decision-making software that integrates and correlates drug delivery with electronic feedback values representing the patient's physiological condition, thereby ensuring safe, cost-effective, optimized care. Significantly, in many cases involving conscious sedation, the patient's physiological condition is inadequately monitored or not electronically monitored at all during drug delivery and recovery therefrom. That is, there is often no electronic monitoring of basic patient vital signs such as blood pressure, blood oxygen saturation (oximetry) nor of carbon dioxide levels in a patient's inhaled and exhaled gases (capnometry). For example, patients undergoing painful procedures in dentists' offices may receive nitrous oxide (N<sub>2</sub>O) gas to relieve pain, but that drug delivery is often not accompanied by electronic monitoring of a patient's physiological condition, and currently there are no devices available to nonanesthetists which safely and effectively integrate electronic patient monitoring with such drug delivery mechanisms.

[0011] In other circumstances involving the provision of conscious sedation and analgesia by the procedural physician, such as a cardiologist's performing a catheterization procedure in a hospital laboratory, electronic patient monitors are sometimes used, but again, there are no devices currently available to the nonanesthetist which safely and effectively integrate both mechanically (through close, physical proximity and incorporation into a structural system), and electronically (through conservative software management), electronic patient monitors with mechanisms for drug delivery.

[0012] One aspect of the invention of this application is directed to the simplification of drug delivery machines for relieving patient pain and anxiety by eliminating features of those machines that complicate the provision of patient pain and anxiety relief, and by including those features that

enable nonanesthetists to provide safe, cost-effective, optimized conscious sedation and analgesia. More specifically, current anesthesia machines used by anesthesiologists to provide general anesthesia and a form of conscious sedation administered by the anesthesiologist known as "monitored anesthesia care" (MAC) include various complex features such as oxygen (O<sub>2</sub>) flush valves which are capable of providing large amounts of oxygen to the patient at excessive pressures, and carbon dioxide (CO<sub>2</sub>) absorbent material which absorbs CO<sub>2</sub> from a patient's exhaled gases. In addition, anesthesia machines typically deliver halogenated anesthetic gases which can trigger malignant hyperthermia. Malignant hyperthermia is a rare, but highly critical condition requiring the advanced training and skills of an anesthesiologist for rapid diagnosis and therapy. The airway circuit in current anesthesia machines is circular in nature and self-contained in that the patient inhales an oxygen/anesthetic gas mixture, exhales that mixture which is then passed through CO<sub>2</sub> absorbent material, re-inhales the filtered gas mixture (supplemented by additional anesthetic and oxygen), and repeats the process.

[0013] These aspects of anesthesia machines, among others, carry attendant risks for the patient such that anesthesia machines require operation by a professional trained through a multi-year apprenticeship (e.g., an anesthesiologist or C.R.N.A.) in detecting and correcting failure modes in the technology. For example, an oxygen flush valve can cause oxygen to enter a patient's stomach thereby causing vomiting; and carbon dioxide absorbent material can fail in which case the patient could receive too much carbon dioxide if the failure was not promptly detected and corrected. Moreover, the use of the self-contained, circular airway circuit could result in a circumstance whereby if the supply of O<sub>2</sub> suddenly ceased, a patient would only be breathing the finite supply of oxygen with no provision for administration of additional requirements for O<sub>2</sub> or atmospheric air. Such features, among others, make anesthesia machines unusable by nonanesthetists. Therefore, a focal point of this aspect of the invention is the simplification of a drug delivery apparatus by selecting and incorporating the appropriate features to facilitate the rendition of safe and effective conscious sedation by nonanesthetists.

[0014] Certain aspects of this invention also focus on ensuring maintenance of patient consciousness to prevent airway difficulties, including monitoring the level of patient consciousness during the delivery of one or more sedative, analgesic and/or amnestic drugs to a conscious, non-intubated, spontaneously-ventilating patient to prevent airway difficulties. For patients not intubated on a ventilator, monitoring the level of patient consciousness is important to provide information about the likelihood of depressed airway reflexes and respiratory drive to breathe, the ability to maintain a patent airway, and the likelihood of cardiovascular instability. Despite the importance of monitoring and maintaining adequate levels of consciousness in certain medical settings, there is no currently available device for ensuring maintenance of patient consciousness by integrating mechanically and electronically such monitoring of a patient's level of consciousness with a drug delivery system. The invention of this application is directed to this unmet need, as well.

[0015] Technological innovations over recent decades have introduced non-invasive or minimally invasive techniques for diagnostic, therapeutic, cosmetic and other procedures.

[0016] These developments have been accompanied by a shift from operating rooms in hospitals to procedure laboratories, ambulatory surgical centers, or office based suites for non-invasive or minimally invasive clinical procedures. These interventions may be inherently painful, constraining or require organ manipulation and thus necessitate active pain management during the procedure. Additionally, patient movement, e.g., as an instinctive response to pain, may lead to sub-optimal performance of the procedure and thus less than ideal outcomes.

[0017] Therefore, the administration of sedation and analgesia has evolved into an integral component of such procedures. The evolutionary nature of administration of sedation and analgesia by non-anesthesiologists, coupled with cyclic shortages of anesthesia personnel, resulted in clinicians across many disciplines developing their own individual sedation algorithms, sometimes without oversight from anesthesiologists. These individual algorithms were usually customized to the procedure, of highly variable quality and inconsistent in their approach to pre-procedure screening, intra-procedure monitoring and discharge criteria.

[0018] One concern about using potent drugs for procedural pain management is the risk of the patient inadvertently slipping into general anesthesia. Inexperienced clinicians may give too little sedation and analgesia (poor pain management, excessive patient movement, poor patient satisfaction). Conversely, too much sedation and analgesia may produce inadvertent general anesthesia (GA) and its attendant risks in the hands of non-anesthesiologists who may not be trained in airway management and resuscitation. Multi-tasked clinicians may not have time or remember to continually perform manual assessment of patient responsiveness as a guide to depth of sedation. Responsiveness is distinct from unconsciousness. A patient may be conscious but unresponsive. For example, a patient may be conscious and able to understand a command but inattentive and thus unresponsive to the command. Thus, loss of responsiveness, as a precursor to loss of consciousness, may provide an earlier warning of impending loss of consciousness. Currently, it does not appear that there is a system available for automatically and continually monitoring responsiveness that is designed for the multi-tasked clinician delivering or supervising sedation and analgesia during a clinical procedure. Inadvertent general anesthesia has more serious implications in an office-based settings and other settings outside of the operating room, especially if there is not immediately available expertise in airway management and resuscitation.

[0019] An automated monitor of responsiveness will likely be most applicable to sedation and analgesia procedures, especially when integrated with drug delivery systems. However, it is also anticipated that an automated monitor of responsiveness will have clinical utility, either as a stand alone monitor or integrated with other physiological monitors or drug delivery systems including PCA (patient controlled analgesia) pumps, in many other settings such as post anesthesia care units, intensive care units and operating rooms.

[0020] This invention is also directed to providing conscious patients relief from pain and/or anxiety in a manner that is cost-effective and time efficient. Current solutions for relieving patient pain and anxiety by drug delivery and electronic monitoring of a patient's physiological condition are expensive and require a great deal of time to set-up and take down. Also, the current requirement or desire for the presence of an anesthesiologist during some medical or surgical procedures increases costs, especially if that desire requires in-patient care as opposed to care in an ambulatory setting. To the extent medical procedures are performed on conscious patients without adequate sedation and analgesia due to the current unavailability of appropriate methods and devices for providing such care (e.g., wound dressing changes in bum wards), such procedures may need to be conducted on numerous occasions, but over short periods of time (due to a patient's inability to tolerate the level of pain), as opposed to conducting a fewer number of more definitive procedures. The requirement of multiple sessions of care also typically involves increased costs. This invention addresses such cost-effectiveness concerns and provides solutions to problems such as those described.

[0021] The invention is further directed to the provision of relief from post-operative or other post-procedural pain and discomfort in remote medical care locations and home care type settings. Current devices may permit certain patients in, for example, a home care type setting, to provide themselves with an increased dosage of analgesic through the use of a patient-controlled drug delivery device, e.g., a device that permits a patient to press a button or toggle a switch and receive more analgesic (often intravenously or transdermally). This practice is sometimes called "PCA" or patient-controlled analgesia. Known commercially available PCA-type devices do not electronically integrate and conservatively manage delivery of analgesics in accord with the electronic monitoring of a patient's physiological condition. This invention focuses on this unmet need, as well.

[0022] An additional aspect of this invention is directed to the integration of a billing/information system for use with an apparatus providing sedation, analgesia and/or amnesia to conscious patients in physician's offices, hospital laboratory or other ambulatory settings or remote medical care locations. Current techniques for automated billing and invoice generating provide inadequate and inefficient methods for tracking recurring revenues derived from repeated use of medical devices such as the apparatus of this invention.

[0023] Other focuses of the invention are apparent from the below detailed description of preferred embodiments.

#### DESCRIPTION OF RELATED ART

[0024] Known machines or methods administered by the nonanesthetist for providing conscious, non-intubated, spontaneously-ventilating patients with sedation and analgesia are unreliable, not cost-effective or are otherwise unsatisfactory. No commercially available devices reliably provide such patients with safe and cost-effective sedation, analgesia and amnesia to conscious patients by integrating and correlating the delivery of sedative, analgesic and/or amnestic drugs with electronic monitoring of a patient's physiological condition. Available drug delivery systems do not incorporate a safety set of defined data parameters so as to permit drug delivery to be conservatively managed electronically in

correlation with the patient's physiological conditions, including vital signs, to effectuate safe, cost-effective and optimized drug delivery to a patient. Available drug delivery systems do not incorporate alarm alerts that safely and reliably free the nonanesthetist practitioner from continued concern of drug delivery effects and dangers to permit the nonanesthetist to focus on the intended medical examination and procedure. Moreover, there are no known patient-controlled analgesia devices that mechanically and electronically integrate and correlate (through conservative software management) patient requests for adjustments to drug dosage and electronic monitoring of patient physiological conditions.

[0025] Known techniques have focused on the delivery of sedation and analgesia to conscious patients with inadequate or no electronic monitoring of patient physiological conditions, including vital signs, and no electronic integration or correlation of such patient monitoring with drug delivery. Other techniques have focused on the provision of anesthesia to unconscious patients with the requirement of an anesthesiologist to operate a complicated, failure-intensive anesthesia machine.

[0026] Presently known nitrous oxide delivery systems such as those manufactured by MatrX Medical, Inc., Accutron, Inc., and others are used primarily in dental offices for providing conscious sedation only. Such devices contain sources of nitrous oxide and oxygen, a gas mixing device and system monitors, but no mechanical or electrical integration of patient physiological condition monitors with drug delivery mechanisms. Similarly, other known drug delivery systems (e.g., intravenous infusion or intramuscular delivery mechanisms) for providing sedatives and analgesics to conscious patients used, for example, in hospital laboratories, do not include mechanical or electronic integration of patient physiological condition monitors with drug delivery mechanisms.

[0027] Anesthesia machines used by anesthesiologists to provide general anesthesia or MAC, such as, by way of example, the NARKOMED line of machines manufactured by North American Drager and EXCEL SE ANESTHESIA SYSTEMS manufactured by Ohmeda Inc., mechanically integrate electronic patient monitors in physical proximity to drug delivery mechanisms. These machines, however, employ features such as O<sub>2</sub> flush valves, malignant hyperthermia triggering agents, CO<sub>2</sub> absorbent material, as well as circular airway circuits, among others, thereby requiring operation by an M.D.A. (or C.R.N.A.) to avoid the occurrence of life-threatening incidents. These devices do not provide for the electronic integration or management of drug delivery in correlation with the monitoring of a patient's physiological condition, much less such electronic management through conservative, decision-making software or logic incorporating established safe data-defining parameters.

[0028] U.S. Pat. No. 2,888,922 (Bellville) discloses a servo-controlled drug delivery device for automatic and continuous maintenance of the level of unconsciousness in a patient based on voltages representative of the patient's cortical activity obtained by means of an electroencephalograph (EEG). The device continuously and automatically increases or decreases in robotic fashion the flow of anes-

thetic gas (or I.V. infusion) in response to selected frequencies of brain potential to maintain a constant level of unconsciousness.

[0029] U.S. Pat. No. 4,681,121 (Kobal) discloses a device for measuring a patient's sensitivity to pain during the provision of anesthesia, by applying a continuous, painful stimulus to the nasal mucosa and regulating the level of anesthesia in response to EEG signals indicating the patient's response to the nasal pain stimulus, with the goal of maintaining a sufficient level of unconsciousness.

[0030] Among other things, none of the above-described known devices manages drug delivery to conscious patients employing conservative decision-making software or logic which correlates the drug delivery to electronic patient feedback signals and an established set of safety data parameters.

[0031] Current techniques for ensuring that the patient remains conscious during sedation and analgesia include conversation or chit chat between the clinician and the patient. Active participation or response to conversation or verbal queries indicates to the clinician that the patient is conscious and responsive because the patient has to be conscious to understand a question and formulate an answer and responsive to be able to answer the question. This technique, in addition to requiring the clinician to engage, and, for example, remember to engage, in chit chat, may not work if the patient and clinician do not speak the same language.

[0032] Among non-subjective methods of assessing consciousness in some regards is the Bispectral Index (BIS) wherein a sensor is placed on the forehead of a patient to capture EEG signals which are then translated into a single number ranging from 100 (wide awake) to 0 (no brain electrical activity). It has been suggested that the BIS monitor can, in principle, help a clinician avoid the under- and over-dosing of a patient. The consciousness or awareness level of the patient is inferred rather than being explicitly part of the actual consciousness monitoring process or method. Thus, the BIS monitor is only as good as the signal processing algorithms that correlate brain electrical activity to a BIS value. When this system has been used to monitor patients under general anesthesia, incidents of unintended awareness have been reported.

[0033] Auditory evoked potentials (AEP) are the electrical signals generated by the brain in response to audible stimuli and have been used to calculate an index representative of the depth of anesthesia. The method comprises subjecting a patient to a repetitive audio stimulus, monitoring AEPs and providing a signal corresponding to the coarseness of the monitored AEP signal as a single number, indicative of anesthetic depth. AEPs like BIS infer anesthetic depth and do not explicitly involve the cognitive ability of the patient in the monitoring process or method.

[0034] Other partially subjective methods of measuring or grading levels of consciousness and/or sedation include the Glasgow Coma Scale for evaluating level of consciousness after head injury. The Ramsay scale is used to assess level of sedation with 1 being "anxious and agitated" and 6 being "asleep; no response to stimulation". With the Ramsay scale, stimulation may be of variable and inconsistent intensity and duration, and, further, interpretation of the response may be

subjective. The Observer's Assessment of Alertness/Sedation (OAA/S) is also subjective both in the delivery of the stimulus and the interpretation of the response. The patient is scored on 4 components: responsiveness (responds readily to name spoken in normal tone to does not respond to mild prodding and shaking), speech (normal to few recognized words), facial expression (normal to slack jaw) and eyes (clear to glazed).

#### SUMMARY OF THE INVENTION

[0035] The invention provides apparatuses and methods to safely and effectively deliver a sedative, analgesic, amnestic or other pharmaceutical agent (drug) to a conscious, non-intubated, spontaneously-ventilating patient. The invention is directed to apparatuses and methods for alleviating a patient's pain and anxiety before and/or during a medical or surgical procedure and for alleviating a patient's post-operative or other post-procedural pain or discomfort while simultaneously enabling a physician to safely control or manage such pain and/or anxiety. The costs and time loss often associated with traditional operating room settings or other requirements or desires for the presence of anesthetists may thus be avoided.

[0036] A care system in accordance with the invention includes at least one patient health monitor which monitors a patient's physiological condition integrated with a drug delivery controller supplying an analgesic or other drug to the patient. A programmable, microprocessor-based electronic controller compares the electronic feedback signals generated from the patient health monitor and representing the patient's actual physiological condition with a stored safety data set reflecting safe and undesirable parameters of at least one patient physiological condition and manages the application or delivery of the drug to the patient in accord with that comparison. In a preferred embodiment, the management of drug delivery is effected by the electronic controller via conservative, decision-making software accessing the stored safety data set.

[0037] In another aspect the invention also includes at least one system state monitor which monitors at least one operating condition of the care system, the system state monitor being integrated with a drug delivery controller supplying drugs to the patient. In this aspect, an electronic controller receives instruction signals generated from the system monitor and conservatively controls (i.e., curtails or ceases) drug delivery in response thereto. In a preferred embodiment, this is accomplished through software control of the electronic controller whereby the software accesses a stored data set reflecting safe and undesirable parameters of at least one operating condition of the care system, effects a comparison of the signal generated by the system state monitor with the stored data set of parameters and controls drug delivery in accord with same, curtailing or ceasing drug delivery if the monitored system state is outside of a safe range. The electronic controller may also activate attention-commanding devices such as visual or audible alarms in response to the signal generated by the system state monitor to alert the physician to any abnormal or unsafe operating state of the care system apparatus.

[0038] The invention is further directed to an apparatus which includes a drug delivery controller, which delivers drugs to the patient, electronically integrated with an auto-

mated consciousness monitoring system which ensures the consciousness of the patient and generates signal values reflecting patient consciousness. An electronic controller is also included which is interconnected to the drug delivery controller and the automated consciousness monitor and manages the delivery of the drugs in accord with the signal values reflecting patient consciousness.

[0039] In another aspect, the invention includes one or more patient health monitors such as a pulse oximeter or capnometer and an automated consciousness monitoring system, wherein the patient health monitors and consciousness monitoring system are integrated with a drug delivery controller supplying an analgesic or other drug to the patient. A microprocessor-based electronic controller compares electronic feedback signals representing the patient's actual physiological condition including level of consciousness, with a stored safety data set of parameters reflecting patient physiological conditions (including consciousness level), and manages the delivery of the drug in accord with that comparison while ensuring the patient's consciousness. In additional aspects of the invention the automated consciousness monitoring system includes a patient stimulus or query device and a patient initiate response device.

[0040] This automated consciousness monitoring system relies on an automated means for monitoring patient responsiveness. Unlike other methods of assessing consciousness, the design of these means uses the cognitive ability of the patient as an integral part of the monitoring paradigm. The technique of providing a query, depending on the cognition or mentation of the patient to recognize and interpret the query or stimulus, formulate a response, and deliver the response ensures that the responsiveness of the patient is being directly measured. This method of measuring responsiveness minimizes the possibility of a false responsive assessment, which would entail a risk of drug overdose and unconsciousness. Because the test is benign and inexpensive, it can be repeated when a patient fails to respond. Repeated tests decreases the risk of a false unresponsive assessment which might result in drug underdose and inadequate pain management during sedation and analgesia.

[0041] Loss of responsiveness may be a predictor of amnesia. A patient who is unresponsive during painful parts of a procedure will have a high probability of not remembering the painful episodes, depending on the severity of the pain and the invasiveness of the procedure. Thus, in anticipation of painful episodes, the ACQ monitor and the ART test may be used to promote amnesia by titrating drugs until the patient is unresponsive. Thus, while patient motion in involuntary reaction to pain may occur, clinicians' concern about patient motion may be attenuated if they know that there is a high probability that there will be no recollection by patients of the painful episodes.

[0042] The invention also provides apparatuses and methods for alleviating post-operative or other post-procedural pain or discomfort in a home care-type setting or remote medical care location. Here the care system includes at least one patient health monitor integrated with patient-controlled drug delivery. An electronic controller manages the patient-controlled drug delivery in accord with electronic feedback signals from the patient health monitors. In a preferred embodiment the electronic controller is responsive to software effecting conservative management of drug delivery in accord with a stored safety data set.

## DESCRIPTION OF THE DRAWINGS

[0043] Other objects and many of the intended advantages of the invention will be readily appreciated as they become better understood by reference to the following detailed description of preferred embodiments of the invention considered in connection with the accompanying drawings, wherein:

[0044] **FIG. 1** is a perspective view of a preferred embodiment of a care system apparatus constructed in accordance with this invention, depicting the provision of sedation, analgesia and/or amnesia to a conscious patient by a nonanesthetist.

[0045] **FIG. 2** is a perspective view of a preferred embodiment of a care system apparatus constructed in accordance with this invention depicting user interface and patient interface devices.

[0046] **FIGS. 3A and 3B** are side-elevational views of a preferred embodiment of an apparatus constructed in accordance with this invention.

[0047] **FIG. 4A** is a block diagram overview of the invention.

[0048] **FIG. 4B** is an overview data-flow diagram depicting the drug delivery management aspect of the invention.

[0049] **FIG. 5** depicts a preferred embodiment of the invention.

[0050] **FIG. 6** depicts a preferred embodiment of a drug delivery system in accordance with the invention.

[0051] **FIGS. 7A-7C** depict the details of a preferred embodiment of the drug source system in accordance with the invention.

[0052] **FIG. 8** depicts a preferred embodiment of an electronic mixer system in accordance with the invention.

[0053] **FIG. 9A** depicts one embodiment of a manifold system in accordance with the invention.

[0054] **FIG. 9B** depicts a second embodiment of a manifold system in accordance with the invention.

[0055] **FIG. 10A** depicts a preferred embodiment of a manual bypass system in accordance with the invention.

[0056] **FIG. 10B** depicts a preferred embodiment of a scavenger system in accordance with the invention.

[0057] **FIG. 11** depicts a preferred embodiment of a patient interface system in accordance with the invention.

[0058] **FIGS. 12A and 12B** are a front perspective view and a side-elevational view, respectively, of a preferred embodiment of hand cradle device constructed in accordance with the invention.

[0059] **FIGS. 13A and 13B** are rear perspective views of a preferred embodiment of hand cradle device constructed in accordance with the invention.

[0060] **FIGS. 14A and 14B** are, respectively, a front perspective view of an alternative embodiment of a hand cradle device constructed in accordance with this invention and a top plan view of a patient drug dosage request device in accordance with the invention.

[0061] **FIG. 15** shows a perspective view of a preferred embodiment of the invention, including a hand cradle device and an ear piece combination oximeter/auditory query device.

[0062] **FIG. 16** is a side-elevational view of an ear piece placed within a patient's ear containing a pulse oximetry sensor and an auditory query in accordance with the present invention.

[0063] **FIG. 17** depicts an alternative preferred embodiment of a care system apparatus constructed in accordance with the invention.

[0064] **FIG. 18** depicts a user interface system in accordance with a preferred embodiment of the invention.

[0065] **FIGS. 19A and 19B** depict the various peripheral devices included in a preferred embodiment of the invention.

[0066] **FIG. 20** depicts a preferred embodiment of a patient information/billing system in accordance with the invention.

[0067] **FIG. 21A** depicts examples of drug delivery management protocols for 3-stage alarm states reflecting monitored patient parameters in accordance with the invention.

[0068] **FIG. 21B** depicts examples of drug delivery management protocols for 2-stage alarm states reflecting monitored system state parameters in accordance with the invention.

[0069] **FIG. 22A** depicts a first embodiment of a user interface screen display in accordance with the invention.

[0070] **FIG. 22B** depicts a second embodiment of a user interface screen display in accordance with the invention.

[0071] **FIG. 23A** is a data-flow diagram depicting an example of the steps performed by the drug delivery management software or logic responsive to patient health monitors in accordance with the invention.

[0072] **FIG. 23B** is a data-flow diagram depicting an example of the steps performed by the drug delivery management software or logic responsive to system state monitors in accordance with the invention.

[0073] **FIG. 24** depicts an example of an ART query cycle in accordance with the invention.

[0074] **FIG. 25** depicts an external view of an alternative embodiment of a handset apparatus constructed in accordance with the present invention.

[0075] **FIG. 26** depicts an internal view of an alternative embodiment of a handset apparatus constructed in accordance with the present invention.

[0076] **FIG. 27** depicts an alternative embodiment of a headset apparatus constructed in accordance with the present invention.

[0077] **FIG. 28** depicts a third embodiment of a user interface screen display in accordance with the invention.

[0078] **FIG. 29** depicts a fourth embodiment of a user interface screen display in accordance with the invention.

[0079] **FIG. 30** depicts a fifth embodiment of a user interface screen display in accordance with the invention.

#### DETAILED DESCRIPTION OF PREFERRED EMBODIMENTS

[0080] The embodiments illustrated below are not intended to be exhaustive or to limit the invention to the precise forms disclosed. The embodiments are chosen and described in order to explain the principles of the invention and its applications and uses, and thereby enable others skilled in the art to make and utilize the invention.

[0081] FIG. 1 shows a care system 10 constructed in accordance with this invention, providing sedative, analgesic and/or amnestic drugs to a conscious, non-intubated, spontaneously-ventilating patient undergoing a medical or surgical procedure by a procedural physician. The system 10 has a generally columnar housing 15 with various storage compartments 16 therein for storage of user and patient interface devices, and a base 17 supported on castor wheels 18. A drug delivery system 40 delivers a mixture of one or more gaseous sedative, analgesic or amnestic drugs in combination with oxygen (O<sub>2</sub>) gas to a patient, and includes a one-way airway circuit 20 connected at one end to a face mask 30 and at the other end to a manifold valving system contained within housing 15. FIGS. 3A and 3B show from a side-elevation perspective, airway circuit 20, face mask 30, and exhaust hose 32 through which scavenged patient exhaled gases are exhausted to a safe location.

[0082] Referring to FIG. 2, lead 50 connects one or more patient interface devices (e.g., 55) to a microprocessor-based electronic controller or computer (sometimes also referred to herein as main logic board, MLB) located within housing 15. The electronic controller or main logic board may be comprised of combinations of available programmable-type microprocessors and other "chips," memory devices and logic devices on various board(s) such as those manufactured by Texas Instruments (e.g., XK21E) and National Semiconductor (e.g., HKL 72, among others). Patient interface devices 55 can include one or more patient health monitors that monitor a patient's physiological condition, such as known pulse oximeter, capnometer (not shown), non-invasive blood pressure monitors; EKG, EEG, acoustical monitors (not shown), and others; an automated consciousness monitoring system, including query initiate and response devices in accordance with the invention (described below); and patient drug dosage request devices (also described below). The main logic board electronically manages operation of the apparatus 10 by means of conservative, decision-making software that integrates and correlates patient feedback signals received from the one or more patient health monitors with drug delivery.

[0083] Also shown in FIGS. 1 and 2 are various user interface devices, including a display device 35 integrated into the top surface of apparatus 10 which displays patient and system parameters and operation status of the apparatus, a printer 37 which prints, for example, a hard copy of patient parameters indicating the patient's physiological condition and the status of various system alarms with time stamps, and a remote control device 45 which permits a physician to interact with apparatus 10. The various patient and user interface devices are described in more detail below.

[0084] It should be recognized that although certain embodiments of the invention show the analgesic delivery system 40 in a form for delivering one or more sedative, analgesic or amnestic drugs in gaseous form, the invention

also specifically includes embodiments where such drugs are delivered intravenously, in nebulized, vaporized or other inhaled form, and/or transdermally such as by using known ion-transfer principles. Drugs that may be delivered by the care system include, but are not limited to, nitrous oxide, propofol, remifentanyl, dexmedetomidine, epibatadine and sevoflurane. Alternative embodiments are described in more detail herein.

[0085] FIG. 4A is a block diagram overview of a preferred embodiment of the invention. FIG. 4B is an overview data flow diagram depicting the drug delivery management steps performed by the software/logic control of microprocessor controller 14 in a preferred embodiment of the invention. In FIG. 4A, one or more patient health monitors 12a (which may include one or more known patient physiological condition monitors such as pulse oximeters, capnometers, other ventilatory monitors, non-invasive blood pressure monitors, EKG, EEG and others, as well as a patient consciousness monitoring system, are electronically coupled, through suitable A-D converters where appropriate, to electronic controller 14, described above. Patient health monitors 12a generate electronic feedback signals representing actual patient physiological data which are converted to electronic signals and then provided to controller 14. Now referring to FIG. 4B, electronic controller 14, e.g., through appropriate software and/or logic, compares the received electronic patient feedback signals 13b with the safety data set 15b stored in a memory device (such as an EPROM device).

[0086] The stored safety data set 14a (FIG. 4A) contains at least one set of data parameters representing safe and undesirable patient physiological conditions. Based on the comparison of the actual monitored patient physiological data 13b with the safety data set 14a, controller 14 determines whether the monitored patient physiological data is outside of a safe range (FIG. 4B, 16b). If the monitored patient data is outside of a safe range, electronic controller 14 sends instruction commands (signals) to drug delivery controller 2a (FIG. 4A) instructing drug delivery controller 2a to conservatively manage (e.g., reduce or cease) drug delivery (FIG. 4B, 18b). Drug delivery controller 2a may be a standard solenoid valve-type electronic flow controller known to those skilled in the art.

[0087] As is described below, additional embodiments of the invention also contemplate provision of electronic feedback signals representing patient-controlled drug dosage increase or decrease requests to controller 14 and electronic management of drug delivery in consideration of such patient requests vis-a-vis the patient's physiological parameters and/or the state of the care system.

[0088] A block diagram of a preferred embodiment of a care system in accordance with the invention is depicted in FIG. 5. Analgesic delivery system 2 of FIG. 5 delivers a mixture of gaseous sedative, analgesic and/or amnestic drugs (such as nitrous oxide, sevoflurane or nebulized narcotics) and oxygen gas to the patient. Manual bypass circuit 4 (shown in further detail in FIG. 6 and FIG. 10A) is coupled to the manifold system portion of analgesic delivery system 2 and bypasses the source of analgesia enabling the manual control of delivery of atmospheric air to the patient. An auxiliary inlet 6 is provided to analgesic delivery system 2 and enables the provision of in-house supply of gaseous

drug or oxygen to the delivery system 2. Scavenger system 8 (shown in detail in FIG. 10B) is coupled to analgesic delivery system 2 and collects exhaled gases from the patient and exhausts them to a safe location through exhaust hose 32 (FIG. 3B).

[0089] Patient interface system 12 includes one or more patient health monitors (these can be known vital sign monitors, such as non-invasive blood pressure monitors, or known pulse oximeters, capnometers, EKGs, etc.); means for monitoring the level of a patient's consciousness; and/or means for the patient to communicate with system 10 (FIG. 1), such as by requesting an increase or decrease in the dosage of drugs. One or more of these patient monitoring and request devices are electronically coupled to and, through A-D converters, provide feedback signals representing the patient's actual physiological condition and drug dosage requests to electronic controller 14. Controller 14 compares this electronic feedback received with data stored in a memory device, said data representing sets of one or more safe and undesirable patient physiological condition parameters (e.g., safe and undesirable O<sub>2</sub> saturation conditions, end tidal CO<sub>2</sub> levels and/or levels of patient consciousness). These sets of parameters are collectively referred to as a safety data set. Based on the comparison, controller 14 commands conservative application of drug delivery in accord with said parameters at safe, cost-effective optimized values.

[0090] Still referring to FIG. 5, user interface system 16 (described in more detail in FIGS. 18 and 22) displays electronic signal values stored in or provided to electronic controller 14, such values reflecting the status of one or more of the patient's physiological state, the patient's level of consciousness, and/or the status of various care system parameters. User interface system 16 includes devices that permit the nonanesthetist to interact with the care system via controller 14 (e.g., input patient information, pre-set drug dosages, silence alarms) such as keyboard 230 (FIG. 2) and/or remote control unit 45 (FIG. 1). Patient and care system information is displayed by means of graphical and numeric display devices, e.g., 35 (FIG. 1), LEDs incorporated into housing 15 (FIG. 1) and/or on remote control unit 45.

[0091] External communication devices 18 (also described in FIGS. 19A and 19B) enable the sending and/or receiving of electronic information signals to and from electronic controller 14 and external computers at remote locations or on local networks. Peripheral devices 22 such as door and temperature sensors, among others, communicate electronically with controller 14 to ensure the proper, safe and secure operation of care system 10.

[0092] The above systems overviewed in FIG. 5 are now described in more detail.

[0093] FIG. 6 shows in further detail an overview of a preferred drug delivery system 2 (FIG. 5) which provides a mixture of one or more sedative, analgesic and/or amnestic drugs in gaseous form; oxygen; and atmospheric air to a patient, the provision of each being independently adjustable (manually and via electronic controller 14) by the physician. The drug delivery system is comprised of a drug source system 42, an electronic mixer system 44 and a manifold system 46.

[0094] Drug source system 42 contains sources of one or more gaseous drugs and oxygen and is coupled through

pneumatic lines to electronic mixer system 42. Drug source system 42 is also electronically coupled to electronic controller 14, and as is described below, contains sensors monitoring one or more operating states of drug source system 42 (e.g., whether the drug is flowing). Such monitored system information is converted to appropriate electronic signals and fed back to electronic controller 14 via the electronic coupling.

[0095] Electronic mixer 44 receives the one or more gaseous drugs, O<sub>2</sub> and atmospheric air through the pneumatic lines and electronically mixes same. Electronic mixer 44 is also electronically coupled to electronic controller 14 and also contains sensors that provide electronic feedback signals reflecting system operation parameters of mixer 44 to electronic controller 14. Mixer 44 includes electronic flow controllers with solenoid valves which receive flow control instruction signals from controller 14.

[0096] Manifold system 46 is coupled through pneumatic lines to and receives the one or more gaseous drugs, O<sub>2</sub> and air mixture from electronic mixer 44 and delivers the mixture to the patient via airway circuit 20 (FIG. 1) and face mask 30 (FIG. 1). Manifold system 46 is also electronically coupled to electronic controller 14 and includes sensors that provide electronic feedback signals reflecting manifold system 46 operation parameters to controller 14. Manifold 46 delivers patient exhaled gases to a scavenging system 48 for exhaust to a safe location via exhaust hose 32 (FIG. 3B).

[0097] Drug source system 42 is shown in further detail in FIGS. 7A-7C. Referring to FIG. 7A, analgesic source system includes drug source system 142 which provides a source of one or more sedative, analgesic and/or amnestic drugs; and an oxygen source system 144 which provides a source of oxygen. In aspects of this invention where the drugs are in gaseous form, the sources of drugs and oxygen provide the gases at low pressure, and can be tanks contained within housing 15 (FIG. 1) such as those shown at numeral 54 in FIG. 2 or an in-house source. The ability to use alternative sources increases the useability of the care system of the invention because the system can function as a source-dependent unit within rooms with access to in-house gas supplies or as a self-contained unit within rooms that do not have in-house gas connections.

[0098] In additional aspects of the invention, drug source system 42 can include one or more of the following: known nebulizers 143 which enable the delivery of aerosolized drugs, such as morphine, meperidine, fentanyl and others; known vaporizers 145 which enable the delivery of halogenated agents, such as sevoflurane; known infusion pump-type drug delivery devices 147 or known transdermal-type drug delivery devices 149 (including ion transfer based devices) to enable the delivery of drugs such as propofol, remifentanyl, and other infusible drugs by continuous or bolus administration.

[0099] FIG. 7B details the oxygen source system and shows an oxygen tank or other source of oxygen 104 and a pneumatic line 109 for delivering oxygen gas to electronic mixer system 44 (FIG. 7A). Filter 106a in oxygen line 109 removes contaminants within the oxygen stream from oxygen source 104. Pressure sensor 106 (which may be of a type known and currently available) in oxygen line 109 monitors the pressure in oxygen source 104 generating a signal reflecting same and thereby indirectly measuring the amount

of oxygen remaining. Pressure sensor **106** is electronically coupled to electronic controller **14** and forwards signals reflecting the measure of pressure in the oxygen source to controller **14**. In a preferred embodiment, electronic controller **14** receives the signal from pressure sensor **106** and through software accesses data parameters stored in a memory device. The parameters reflect one or more set-points establishing safe and undesirable operating conditions of O<sub>2</sub> operating pressure. Controller **14** compares the actual O<sub>2</sub> pressure to the stored parameter set point data. If the comparison reveals that the O<sub>2</sub> pressure is outside of an established safe range as established by the stored data, an alarm or other attention-commanding device activates and if same is not manually deactivated, electronic controller **14** instructs the flow of drug delivery to reduce to a pre-set safe amount (or cease). The operation of the software control vis-a-vis system state monitors is described in more detail in connection with FIGS. **21B** and **23B**.

[**0100**] The signal obtained from oxygen source pressure sensor **106** can be related to the user via display devices (e.g., **35**, FIG. **2**) in terms of the time remaining under present use so that the user can ascertain if the procedure can be completed. The user is immediately notified if the pressure falls out of the normal operating conditions by an alarm, display device or other suitable attention-commanding device. Pressure gauges **108** visually display to the user the oxygen source pressure obtained by sensor **106**. Pressure regulator **110**, which may be of a known solenoid type currently available or other suitable regulator, enables the reduction of pressure in oxygen source **104** to a reasonable operating pressure to provide flow of O<sub>2</sub> to the patient. Check valve **112** (check valves may be of a standard one-way type), in oxygen line **109** downstream of regulator **110** prohibits backward flow of the patient's exhalations and ensures that such back-flow does not damage or contaminate regulator **110** and oxygen source **104**. In systems where an in-house oxygen source **105** is used, remote check valve **114** ensures that back-flow from the patient's exhalations does not damage or contaminate in-house oxygen source **105**. Pressure relief valve **116** exhausts oxygen to the atmosphere if the pressure in oxygen line **109** exceeds safe operating values pre-programmed into electronic controller **14**.

[**0101**] FIG. **7C** details the drug source system and in a preferred embodiment includes a tank or other source of drug **204** and a pneumatic line **209** for delivering gaseous drugs to electronic mixer **44**. Filter **206a** in drug line **209** removes contaminants within the drug stream from drug source **204**. Pressure sensor **206** (which may be of a type known and currently available) in drug line **209** monitors the pressure in drug source **204** generating a signal reflecting same and thereby indirectly measuring the amount of drug. Pressure sensor **206** is electronically coupled to electronic controller **14** and forwards signals reflecting the measure of pressure in the drug source to controller **14**. As is described above in connection with oxygen source pressure sensor **106** and in FIGS. **21B** and **23B**, in a preferred embodiment controller **14** receives the signal from sensor **206** and through software accesses stored data parameters reflecting safe and undesirable operating conditions of drug source pressure and conservatively controls drug delivery in accord with said stored parameters.

[**0102**] The signal obtained from the drug source pressure sensor **206** can be related to the user via display devices

(e.g., **35**, FIG. **2**) in terms of the time remaining under present use so that the user can ascertain if the procedure can be completed. The user is immediately notified via an alarm, display device or other suitable attention-commanding device if the pressure falls out of the normal operating conditions. Pressure gauges **208** visually display to the user the drug source pressure obtained by sensor **206**. Pressure regulator **210**, which may be of a known solenoid type currently available, enables the reduction of pressure in drug source **204** to a reasonable operating pressure to provide flow of drug to the patient. Check valve **212** in drug line **209** downstream of regulator **210** prohibits backward flow of the patient's exhalations and ensures that back-flow from the patient's exhalations does not damage or contaminate regulator **210** and drug source **204**. In systems where an in-house drug source **205** is used, remote check valve **214** ensures that back-flow from the patient's exhalations does not damage or contaminate in-house drug source **205**. Pressure relief valve **216** exhausts the drug to the atmosphere if the pressure in drug line **209** exceeds safe operating values pre-programmed into electronic controller **14**.

[**0103**] To increase safety, the known pin indexed safety system (P.I.S.S.) and/or diameter indexed safety system (D.I.S.S.) may be used for all O<sub>2</sub> source and line fittings where appropriate for tank and/or in-house sources. This ensures, for example, that oxygen source **104** is not mistakenly attached to the drug line **209** and vice versa.

[**0104**] FIG. **8** details a preferred electronic gas mixer system which electronically mixes gaseous drugs and oxygen so that the precise flow rate of gaseous drug and oxygen is delivered to the patient. The use of the electronic mixer system of this invention increases the operational safety of the apparatus of the invention because, as described below, the volume of drug delivery can be electronically controlled in closed-loop fashion by currently available electronic flow controllers which include solenoid type valves which, in response to command signals from electronic controller **14**, halt or reduce the flow of drugs to the patient in the event of an occurrence of unsafe patient or system conditions. Specifically, pneumatic oxygen line **109** and drug line **209** from analgesic source system **42** deliver gaseous drugs and oxygen to filters **125** and **127** in lines **109** and **209**, respectively, which filter contaminants from lines **109** and **209**. System state monitors, namely, pressure sensors **129**, **131**, monitor the oxygen and gaseous drug line pressures, respectively, and transmit signals reflecting said pressures to electronic controller **14**, which conservatively controls drug delivery in accord with a stored data set containing parameters reflecting one or more safe and undesirable system operation states as described above and in FIGS. **21B** and **23B**. Also, if any of the pressures fall out of the norm, electronic controller **14** immediately alerts the user, for example, by means of signaling an alarm device.

[**0105**] Electronic flow controllers **133**, **135**, which may be of a known type currently available including solenoid valves, are electronically coupled to and receive instruction signals from electronic controller **14** which has been programmed with and/or calculates a desired flow rate of oxygen and drug. Programmed flow rates may be those input by the physician user employing traditional choices regarding drug administration amounts and rates, including in IV embodiments, target controlled infusion principles, among others. Calculated flow rates may be arrived at through

conservative decision-making software protocols including comparison of actual patient physiological condition feedback values with stored data representing safe and undesirable patient physiological conditions. Drug delivery is effected at the rates calculated in a closed, control-loop fashion (described in more detail below) by flow controllers **133**, **135**. Drug administration may be a combination of one or more physician inputs and/or electronic flow rate calculations based on patient and system state parameters; flow controllers may respond to instruction signals initiated by electronic controller **14** or by the physician.

[0106] Flow controllers **133**, **135** receive instruction signals from controller **14** reflecting the electronic output of both system state monitors (such as pressure sensors **106**, **206** described above) and patient state monitors. Flow controllers **133**, **135**, in response to instruction signals from controller **14**, may curtail or cease flow of drug delivery when system state and/or patient health monitors indicate to controller **14** that failures in the operation of care system **10** have occurred, that system **10** is otherwise operating outside of an established safe state, or that a patient's physiological state (e.g., vital signs or consciousness level) has deteriorated to an unsafe condition.

[0107] As the invention includes both intravenous and gaseous, among other forms of drug delivery, such embodiments may also include known electronic flow controllers coupled to electronic controller **14** and responsive to instruction signals from controller **14** reflecting both patient and system states.

[0108] Referring again to **FIG. 8**, solenoid valve **132** is electronically coupled to electronic controller **14** and must be activated by same before drug will flow through line **209**. In the event of system power failure, drug delivery will be halted due to the fail-closed nature of solenoid valve **132**. This is described, for example, in **FIG. 21B** which shows that if a system state monitor indicates power failure, alarm type "2" sounds to alert the nonanesthetist and drug delivery is halted (i.e., reduced to 0%).

[0109] Moreover, pressure actuated valve **134** in drug line **209** responds to the amount of pressure in O<sub>2</sub> line **109** and permits flow of gaseous drug only if sufficient oxygen flows through oxygen line **109**. Check valve **136a** in drug line **209** ensures that the flow of gaseous drug to manifold system **46** is one-way and that there is no back-flow. Check valve **136b** in oxygen line **109** ensures one-way flow of O<sub>2</sub> to manifold system **46** with no back-flow.

[0110] In atmospheric air line **139**, air inlet solenoid valve **137** is electronically coupled to and activated by electronic controller **14** and if activated permits atmospheric air to be mixed with the oxygen gas by means of air ejector **138**. Air ejector **138** injects a fixed ratio of atmospheric air into oxygen line **109**. Filter **128** removes contaminants from air line **139** and check valve **136c** ensures one-way flow of air from solenoid valve **137** to ejector **138** with no back-flow.

[0111] Referring to **FIG. 9A** which details one embodiment of manifold system **46** (**FIG. 6**), the drug/O<sub>2</sub> gas mixture from electronic mixer system **44** (**FIG. 6**) enters manifold system **46** and flows into inspiratory plenum **150** from which it proceeds through inspiratory line **151** to primary inspiratory valve (PIV) **152** and eventually to airway circuit **20** and mask **30** (**FIG. 1**). Primary inspiratory

valve **152** permits one-way flow of said gas mixture and ensures that exhaled gases from the patient do not enter the inspiratory side of manifold system **46** (**FIG. 6**), thereby guarding against possible contamination. Atmospheric air may be permitted to enter inspiratory line **151** through an inspiratory negative pressure relief valve (INPRV) **154** which allows one-way flow of atmospheric air to reach the patient if a significant negative vacuum is drawn on the inspiratory side of manifold system **46** (e.g., the patient inhales and receives no or insufficient oxygen). INPRV **154** thereby essentially permits air on demand by the patient. INPRV filter **153** removes particulates which may be in air line **155** or present in the atmosphere. INPRV status sensor **156** (which may be of a known pressure, temperature, infra-red or other suitable type) monitors the extent of open/close status of INPRV **154** and generates a signal which is converted to an appropriate electronic (digital) signal and communicates the status of INPRV **154** to electronic controller **14**. During the exhalation phase of the patient's breathing cycle, inspiratory reservoir bag **149** collects the drug/O<sub>2</sub>/air mixture which the patient will draw on the next inhalation phase.

[0112] Still referring to **FIG. 9A**, pressure sensor **166** measures pressure in airway circuit **20** (**FIG. 1**) and is used to indicate airway flow, i.e., if the primary inspiratory valve (PIV) **152** or the primary expiratory valve (PEV) **168** is occluded. For example, if sensor **166** reads a high pressure that indicates that PEV **168** is blocked, whereas a low pressure indicates PIV **152** is blocked. Airway circuit **20** (**FIG. 1**) also contains a fraction of inspired oxygen (FIO<sub>2</sub>) sensor **167** (which may be of a known type currently available) which measures the oxygen percentage of gas contained in the mixture delivered to the patient, and thus guards against the possibility of delivering a hypoxic mixture to the patient (i.e., a drug/O<sub>2</sub> mixture that does not provide enough O<sub>2</sub> to the patient). INPRV status sensor **156**, pressure/airway flow sensor **166**, and FIO<sub>2</sub> sensor **167** are electronically coupled to and provide electronic feedback signals reflecting system state parameters to electronic controller **14**. As described in **FIGS. 21B and 23B**, controller **14**, through software and/or logic, effects a comparison of the signals generated by these system monitors with a stored data set of system parameters established by setpoints and/or logic-type data reflecting safe and undesirable system operating states, and conservatively controls (e.g., reduces or halts) drug delivery if the comparison determines that care system **10** is operating outside of a safe range.

[0113] Airway circuit and mask (**20**, **FIG. 9**) interface with the patient to provide a closed circuit for the delivery of drug/O<sub>2</sub> gas mixture to the patient. It should be recognized that embodiments of the subject invention in which the drugs are delivered in a form other than compressed gas, such as intravenously or transdermally, may not include face masks, airway circuit features and other aspects associated with delivery of drugs in gaseous form. Where the drug is delivered in gaseous form and an airway circuit and face mask are employed, such face mask and attendant airway circuitry and other features such as the scavenging system may be in the form of that described in U.S. Pat. No. 5,676,133 issued to Hickle et al. and entitled Expiratory Scavenging Method and Apparatus and Oxygen Control System for Post-Anesthesia Care Patients. (With respect to such embodiments, the specification of Hickle et al. is incorporated herein by reference.)

[0114] In preferred embodiments the mask is disposable and contains means for sampling the CO<sub>2</sub> content of the patient's respiratory airstream and, optionally, means for also measuring the flow of the patient's airstream and/or means for acoustical monitoring. The sampling of the CO<sub>2</sub> in the patient's airstream may be done by means of a capnometer or a lumen mounted within the mask through a port in the mask, and placed close to the patient's airway. A second lumen similarly mounted within the mask could be used to measure the airflow in the patient's airstream. This airflow measurement could be accomplished by a variety of currently available devices, including for example, devices that measure the pressure drop in the airstream over a known resistance element and thereby calculate the airflow by known formula. The means for acoustical monitoring may be a lumen placed within the mask with a microphone affixed within that lumen. The microphone would permit recording, transducing and playing out through an amplifier the audible sound of the patient's breathing. It is noted that the lumen for acoustical monitoring could be a separate lumen or could be combined with the lumen for calculating the flow of the patient's airstream. It is further noted that it is important to place the lumens, especially the CO<sub>2</sub> sampling lumen, close to the patient's open airway and to ensure such lumens remain close to the patient's airway.

[0115] Referring again to FIG. 9A, primary expiratory valve (PEV) 168 in expiratory line 172 ensures one-way flow of a patient's exhaled gases to scavenger pump system 48, thus, prohibiting any back-flow from gases exhaled to the scavenger system from reaching the patient. Importantly, PEV 168 guards against the re-breathing of exhaled carbon dioxide. As is easily seen, the manifold 46 and airway circuit 20 of a preferred embodiment of this invention permit one-way airway flow only. That is, unlike prior devices that employ circular airway circuits (which require CO<sub>2</sub> absorbent material to permit re-breathing of exhaled air), there is no re-breathing of exhaled gases in this embodiment of the invention.

[0116] In the embodiment of the invention shown in FIG. 9A, expiratory positive pressure relief valve (EPPRV) 164 in expiratory line 172 allows exhaled gases to escape to the atmosphere if sufficient positive pressure develops on the expiratory side of the manifold system. This could happen, for example, if the patient is exhaling, but scavenger system 48 (FIG. 6) is occluded or otherwise not working properly. EPPRV filter 175 downstream of EPPRV 164 filters contaminants from the expiratory stream flowing through EPPRV 164 prior to the stream entering the atmosphere. Expiratory negative pressure relief valve (ENPRV) 178 is a one-way valve that allows atmospheric air to be drawn into expiratory plenum 180 and then on to scavenger system 48 if sufficient vacuum pressure is drawn on the expiratory side of manifold system 46. This could happen, for example, if the vacuum pump of scavenger system 48 is set too high or PEV 168 is blocked. Expiratory reservoir bag 177 collects exhaled gases from the patient during exhalation via expiratory plenum 180. These gases will be exhausted by scavenger system 48 during the next patient inhalation phase. As is described in detail below, patient vital sign monitor, such as a capnometer 184, monitors the amount of CO<sub>2</sub> in the patient's exhaled gases and provides electronic feedback signals reflecting the level of CO<sub>2</sub> in the patient's exhalations to controller 14. Other types of ventilatory monitors such as an airflow measure, IPG device or an acoustical

monitor could also be used to provide electronic feedback signals reflecting patient health parameters to controller 14.

[0117] In an alternative preferred embodiment shown in FIG. 9B, ENPRV 164, filter 175 and ENPRV 178 are eliminated. A long pipe or similar conduit 175a, interconnected with reservoir bag 177 and opening to atmospheric air, is substituted therefor. The elimination of the valves 164 and 175 provides for a more cost efficient and simple system, while the substituting of the pipe 175a still ensures that if the scavenger system 48 is occluded, is set too high, is otherwise not working or if PEV 168 is blocked, that there is still access to atmospheric air, and the patient may breath into the room or air may come into the system. A highly compliant reservoir bag 179 also assists in catching excess flow of exhaled air. In this simplified embodiment, there are essentially only three valves, PIV 152, PEV 168 and INPRV 154.

[0118] As is described above, system valves PIV 152 and PEV 168 ensure one-way flow of inspired and expired gases. The patient cannot re-breathe exhaled gases and no contaminants are allowed to enter the source system. The valve system INPRV 154, EPPRV 164, and ENPRV 178 (or the alternate INPRV 154 and pipe) provides a system fail-safe. If analgesic source system 42 (FIG. 6) or scavenging system 48 (FIG. 6) is functioning improperly, the valves will open and allow the patient to breath without significant effort. The system state sensors 156, 166 and 167 monitor system operation such as INPRV valve status, gas pressure and fraction of inspired oxygen, and electronically feed back signals reflecting the operating status of those operations to microprocessor controller 14 to ensure safe operation of the apparatus.

[0119] It is noted that the valves and sensors between INPRV 154 and ENPRV 178 in a preferred embodiment of manifold system 46 can be considered a system state monitoring system because there are no valves controlled by the software of electronic controller 14. At this point in the care system 10, the gas has already been mixed and the volume determined by the flow controllers 133, 135 (FIG. 8). Manifold system 46 (FIG. 6) provides at least two basic services, sensor inputs for FiO<sub>2</sub> and CO<sub>2</sub> (167, 184 of FIG. 9) and flow status derived from flow sensor 166 (FIG. 9).

[0120] The determination of appropriate drug delivery/flow percentages by controller 14 can be accomplished through a variety of methods. Initial drug administration amounts and rates may be selected and input by the physician employing traditional methods. Physicians may also employ pharmacokinetic/pharmacodynamic modeling to predict resulting drug concentrations and their effect based on physician choices, but not permit automatic changes to drug concentrations without instructions from the physician. In intravenous embodiments known target-controlled infusion techniques may be employed where the physician selects a desired (targeted) blood serum or brain effective site concentration based on such patient parameters as height, weight, gender and/or age.

[0121] During operation of the system when an internal or external event occurs, such as the activation of a system or patient health monitor alarm or a physician or patient request for increased drug, electronic controller 14 determines the desired amount of intravenous drug (or fractional amount of O<sub>2</sub>, gaseous drug and air in the total gas flow) as the function of such event. The actual IV drug concentrations (or gaseous

drug/O<sub>2</sub>/air fractions) are then calculated. These actual calculated amounts will not always be the same as those requested (e.g., by the user, patient or system) because of the often complex relationship between drug or drug and gas mixtures. In sum, drug mix fractions are typically calculated when, for example, an alarm levels change, alarm time-outs occur (e.g., there is no silencing of an initial alarm by the user), a user requests a change, the patient requests a change, when a procedure begins (system resorts to default values) and when a controller clock triggers.

[0122] In a preferred embodiment of the invention delivering gaseous drugs, flow controllers in mixer 44 (detailed in FIG. 8) determine the total fresh gas flow (FGF) which is the sum of the volumes of each gas being controlled, namely, the gaseous drug, oxygen and atmospheric air. Solenoid valves are opened proportionally to achieve the desired FGF and fractional amount of each gas. Flow controllers 133, 135 close the feedback loop on the gas fractions by measuring the FiO<sub>2</sub> and fraction of inspired gaseous drug in the manifold system 46 and adjusting the mixer solenoid valves accordingly.

[0123] In one aspect of the invention, the flow controllers 133, 135 match the FGF with patient minute ventilation rates. The minute ventilation rate is the volume of breath one inhales and then exhales (e.g., in cubic centimeters or milliliters) in one minute. A patient's respiratory physiology is balanced at this minute ventilation. The care system optimizes FGF rates by matching gas delivery to patient minute ventilation rates. This conserves gas supplies, minimizes the release of anesthesia gases into the operating environment, and helps balance respiratory function. For example, if the FGF is less than the minute ventilation, INPRV 154 will open to supplement the air flow (INPRV 154 being a mechanical system not under electronic control).

[0124] In an additional aspect of the invention, the care system will not only measure and monitor minute ventilation as described above, but also "effective minute ventilation" and thereby improve the quantitative information about patient physiology considered by the system. "Effective minute ventilation" is a term used herein to mean the amount of gas that is actually involved in respiratory gas exchange between the alveolar sacs of the lungs and the capillary blood surrounding those sacs (as opposed to simply the volume of gas one inhales and then exhales, "tidal volume"). This measure may be arrived at by subtracting the volume of anatomical space imposed between the air source (e.g., mouth) and the transfer of gas at the alveolar sacs (estimated from the patient's height and weight), from the tidal volume of gas to arrive at "effective tidal volume." The effective tidal volume is then multiplied by respiratory rate to arrive at "effective minute ventilation."

[0125] FIG. 10A details manual bypass system 4 (FIG. 5) which is coupled to manifold system 46. The bypass system 4 includes a self-inflating resuscitation bag (SIRB) 19a (also shown in FIG. 3B) which is a manual pump with which the user can provide air intermittently to the patient through a bypass air line 90. A quick disconnect type fitting 91 (such as that disclosed in Hickle above) couples SIRB 19a with manifold system 46 and provides rapid attachment thereto. A manual flow control valve 92 opens or closes bypass air line 90. When line 90 is open, manual flow control valve 92

can be adjusted to provide the necessary air flow. A flow meter 94 placed in bypass air line 90 provides a visual display to the user of the status of air flowing through the bypass air line 90. The above-described manual bypass system 4 provides the patient with manually-controlled flow of air and thus enables air delivery in the case of an oxygen source system 144 (FIG. 7A) failure.

[0126] FIG. 10B details scavenger pump system 48 (FIG. 6) which is integrated into the care system and vacuums exhaled gases from manifold system 46 through a scavenging line 85. A filter 86 in scavenging line 85 removes contaminants from the gases which have been exhaled from the patient and which are flowing through the scavenger line 85. Pressure regulator 87 receives the filtered gases and ensures that the vacuum pressure is maintained in vacuum pump 95 downstream at a reasonable working level. Flow restrictor 88 sets the flow rate through the vacuum 95 for a given vacuum pressure. Check valve 89 downstream of flow restrictor 88 provides one-way flow of scavenged gases, and thus ensures that back-flow does not inadvertently flow into scavenger system 48 from the vacuum pump 95 downstream. Vacuum pump 95 provides the vacuum pressure necessary for scavenging of exhaled gases from the patient. The pump may be of an electrical type that can be powered by office standard AC current. As the vacuum pump is integrated into the care system, a wall vacuum source (such as that typically in an OR) is not required. Once the gases are vacuumed off, they are exhausted via exhaust hose 32 (FIG. 3B) to an appropriate area. The benefit of scavenging system 48 is at least two-fold in that the system helps assist the patient in the work of breathing and work environment safety is increased.

[0127] In a preferred embodiment, an emesis aspirator 19 (FIG. 3B) is integrated into system 10 and may be stored within housing 15. Emesis aspirator 19 is a manually operated device used to suction a patient's airway in the event of vomiting. Emesis aspirator 19 does not require an external vacuum source (e.g., wall suctioning) or electrical power for operation.

[0128] To enhance the safety of the invention, housing 15 may include structure integrated adjacent or otherwise near where emesis aspirator 19 is stored within housing 15 (FIG. 3B) to hold and prominently display containers of drugs capable of reversing the effects of various sedatives/anesthetics. These "reversal drugs," such as naloxone, remazicon and others may be immediately administered to the patient in the event of an overdose of sedative, analgesic and/or amnestic.

[0129] Referring to FIG. 11, a preferred embodiment of the invention includes an integrated patient interface system which combines one or more patient health monitors 252 (additional health monitors to those shown are also contemplated by the invention) with additional automated patient feedback devices including a patient drug dosage increase or decrease request device 254 and an automated consciousness query system 256 for monitoring a patient's level of consciousness. These health monitors 252 and automated patient feedback devices 254, 256 are electronically coupled to electronic controller 14 via leads (e.g., 50, FIG. 2) and provide electronic feedback values (signals) representing the patient's physiological condition to controller 14. Generally, if any monitored patient parameter falls outside a normal range (which may be preset by the user or otherwise

preprogrammed and stored in memory device as described above), the nonanesthetist is immediately alerted, for example, by an alarm, display or other attention-commanding device. The information obtained from patient health monitors **252** is displayed on a display device **35** (FIG. 2), in, for example, continuous wave form or numerics on LEDs, thus allowing the procedural physician to immediately gain useful information by reviewing the display device. Preferred embodiments of displays contemplated by the invention are described in more detail below.

[0130] A preferred embodiment of one aspect of the invention integrates drug delivery with one or more basic patient monitoring systems. These systems interface with the patient and obtain electronic feedback information regarding the patient's physiological condition. Referring to FIG. 11, a first patient monitoring system includes one or more patient health monitors **252** which monitor a patient's physiological conditions. Such monitors can include a known pulse oximeter **258** (e.g., an Ohmeda **724**) which measures a patient's arterial oxygen saturation and heart rate via an infra-red diffusion sensor; a known capnometer **184** (e.g., a Nihon Kohden Sjsi2) which measures the carbon dioxide levels in a patient's inhalation/exhalation stream via a carbon dioxide sensor and also measures respiration rate; and a known non-invasive blood pressure monitor **262** (e.g., a Criticon First BP) which measures a patient's systolic, diastolic and mean arterial blood pressure and heart rate by means of an inflatable cuff and air pump. A care system constructed in accordance with this invention may include one or more of such patient health monitors. Additional integrated patient health monitors may also be included, such as, for example, a measure of the flow in a patient's airstream, IPG ventilatory monitoring, a standard electrocardiogram (EKG) which monitors the electrical activity in a patient's cardiac cycle, an electroencephalograph (EEG) which measures the electrical activity of a patient's brain, and an acoustical monitor whose audio signals may be processed and provided to controller **14** and amplified and played audibly.

[0131] A second patient monitoring system monitors a patient's level of consciousness by means of an automated consciousness query (ACQ) system **256** which manages the administration of an automated responsiveness test (ART) (FIG. 11). The ACQ system **256** comprises one or more query initiate devices **264**, and one or more query response devices **266**, as well as communication connections between each of these components. ACQ system **256** is electronically coupled to electronic controller **14** and the signals generated by ACQ system **256** are suitably converted (e.g., employing an A-D converter) and thereby provided to controller **14**. Preferably, an interface is also provided for clinicians to interact with the ACQ system **256** and to control it. Clinicians may select to operate many of the ART functions manually or allow the ACQ system **256** to automatically control the functions. The ACQ system **256** may use the results of an ART to assess a patient's level of consciousness or responsiveness by the procedure described below. The knowledge of the level of a patient's consciousness or responsiveness may then be used to initiate, cease, or modify the functions of the ACQ system **256** or the functions of the care system **10**. The ACQ system **256** may itself be provided as a component of any larger medical system, such as the

care system **10**, the safe and proper use of which would be aided by the knowledge of a patient's level of consciousness or responsiveness.

[0132] The query initiate devices **264** are placed near, on, or are held by the patient and generate events which are recognizable by the patient as prompts for him or her to respond with a particular action. An ART query cycle consists of a series of events at preordained intervals, occurring over a preset amount of time. The query response devices **266** are also placed near, on, or are held by the patient and are constructed so as to sense a particular action the patient may make. Upon sensing the particular action, the query response devices **266** produce a signal that is noted by the controller **14**. (The patient is preferably coached before the administration of an ART query on how to recognize the events and how to respond with the particular action.) The controller **14** is configured to make certain assessments based upon the time between the initiation of the events and the patient's responding action. This amount of time is sometimes referred to as the "latency period." The controller **14** is also configured to recognize the absence or lateness of any patient response relative to a given time frame and make certain assessments based on such absence or lateness. The controller **14** may output indications of its assessments to the user interface, if such is provided. The controller's assessments may also be used by the care system **10** or other systems or sub-systems to alter or to prompt certain of their actions.

[0133] If the latency period is determined by controller **14**, which employs software to compare the actual latency period with stored safety data set parameters reflecting safe and undesirable latency period parameters, to be outside of a safe range, the clinician is notified, for example, by means of an alarm or other attention-commanding device. If no action is taken by the clinician within a pre-set time period, controller **14** commands the decrease in level of sedation/analgesia/amnesia by control and operation on electronic flow controllers **133**, **135** of FIG. 8. The values of the signals reflecting the latency period are displayed on display device **35** (or on LED devices located on housing **15** or on remote control device **45**, FIG. 1) and the clinician may thus increase or decrease drug delivery based on the latency period.

[0134] The stimuli produced by the query initiate devices **264** may be tactile, visual, or aural. Each event may comprise a single or more than one type of stimulus. One device may produce any or all of the possible stimuli or the ACQ system **256** may utilize different devices, wherein each is designated for producing a particular type of stimulus. Tactile stimuli may include one or more of vibrations, electrical pulses, pressure changes, pinpricks, pinching or temperature changes. The devices producing such stimuli are preferably placed near or on the patient's skin or are held by the patient in his or her hand. Visual stimuli may include one or more of sequences of images or text or simply pulses or patterns of light. The devices producing such stimuli are preferably placed near or on a patient's eyes. Aural stimuli may include certain sounds, tones, musical samples, or verbal messages and are preferably produced by devices that are placed on or near the patient's ears.

[0135] Each query initiate device **264** is capable of generating at least one, but preferably more than one intensity

of its stimuli. For example, the motor in a vibrator device may operate at varying revolutions per minute (RPM) and a verbal message device may play messages with different levels of urgency and/or volume. The maximum level of tactile stimuli should be produced to maximize the probability of eliciting a response from the patient, and may include, for some applications, a painful stimulus. The verbal message may, for early events in an ART query cycle, be of a pleasant and agreeable voice so as to not annoy or irritate those patients at low depths of sedation who are very responsive and in tune with the ART monitor in situations where the ART query cycles are repeated over time. The tone may then be more insistent with subsequent events within the ART query cycle if the patient has not responded to the early audible prompt. The latest events may include verbal messages of a demanding tone and louder volume to reach the maximum recruitment of a response. **FIG. 24** shows example verbal messages for each of these three categories of event stimuli.

[0136] By varying the intensity level of the stimuli, the controller **14** has an increased likelihood of eliciting a response from a patient who is distracted or not completely in tune with the testing at first. For instance, if a patient fails to respond to a low intensity stimulus because he or she is otherwise distracted while that stimulus occurs, he or she may respond to the test if the intensity level of the stimulus is increased and manages to grab the patient's attention, thus reducing the risk of a false unresponsive assessment. Most embodiments of the ART monitor, which vary the intensity of the stimuli, begin a prompt with stimuli of a low intensity so that patients who are responsive will not be unduly irritated, as might be the case if the most intense stimuli were used right away, at the start of an ART query cycle. The systems of these embodiments only increase the intensity of the stimuli when the patient fails to respond to prompts of the lower intensity stimuli. Which stimulus intensity the devices generate is controlled by the controller **14**. Further, if the patient does not respond to a complete cycle of stimuli, the entire cycle can be repeated one or more times to confirm the patient's lack of responsiveness.

[0137] The query response devices **266** are constructed so as to either directly or indirectly sense a patient's response to an event. These devices may directly sense a response where that response is a physical action upon the accepting device itself. A direct query response device **266** may include a button, switch, trigger, toggle, or any other element which accepts a physical action on the part of the patient. For example, a patient may respond to a stimulus event by pressing a button on the acceptance device or by squeezing individual parts of the device together. The devices may also or may instead detect patient response actions indirectly where those actions are actions not directly on the device. Indirect responses may include audible sounds, such as verbal responses detected by a microphone or pressure transducer, motion by any portion of the patient's body as detected by a motion sensor, or physiological changes (heart rate, blood pressure, brain activity, or the like) the aspects of which are indicative of a patient response.

[0138] The controller **14** begins atest by signaling for an event, as comprised by each of the query initiate devices **264** in use by the ACQ system **256** generating their respective stimuli at their respective designated times. The event constitutes a prompt of the patient to respond with the particular

action. The event will continue for a period of time  $t_1$  or until the patient responds to the prompt. If the patient responds within time  $t_1$  and the query response devices **266** have detected the response, the devices will send a signal to the controller **14**. The controller **14** then registers the elapsed time between the beginning of the first event or the start of the ART query cycle and the response and may also return a signal to the query initiate devices **264** that causes them to cease the event, thereby ending the stimuli. If the patient does not respond to the prompt within time  $t_1$ , the controller **14** may send a signal to the query initiate devices **264** to begin a new event. The new event may comprise stimuli of the same type and intensity as the first event, but it is preferred that the second event comprise stimuli that are more intense or are presented with more urgency than the stimuli of the previous event. Upon a second event, the same sequence as with the previous event is continued, i.e., the patient is given time  $t_2$  to respond to the second event; if he responds, the event is over and the response time is recorded; but if the patient still fails to respond within  $t_2$  from the beginning of the second event, the event ends. This process may continue for a number of events (which may be clinician-defined) within each ART query cycle. The times  $t_1$ ,  $t_2$ ,  $t_3$ , etc. may be clinician defined and need not be of the same duration.

[0139] The ACQ system **256** or monitor is capable of generating each successive event, should more than one occur, in a continuous stream of stimuli where the stimuli increase in intensity with each event. However, a pause of time  $t_{\text{pause}}$  between events may also be instituted by the ACQ system **256** so the patient does not become acclimatized to the early stimuli of lower intensity thereby not recognizing the stimuli of higher intensity. Patients who do not recognize stimuli at a low intensity and, therefore, do not respond to them, may be more likely to respond to a subsequent event with increased intensity if there is a pause between the events. The pause times,  $t_{\text{pause1}}$ ,  $t_{\text{pause2}}$ , etc., may be clinician defined and need not be of the same duration. In an embodiment having a maximum of three events per test and pauses between each event, the total time of the ART query cycle can be up to  $t_1 + t_{\text{pause1}} + t_2 + t_{\text{pause2}} + t_3$ . This total response period is usually short, 14 seconds in one particular embodiment of the ACQ system **256**. Patients may respond at any time during an ART query cycle, including during the pause periods. The patient's response time is measured and recorded by the controller **14** as the time between the beginning of the first event or the start of the ART query cycle and the patient's response whenever it occurs during the ART query cycle. The absence of a patient response during the response period (including a patient response after the preset response period, e.g., 14 s) is recorded as a failed response.

[0140] Particular embodiments of the ACQ system **256** feature both tactile and aural stimuli producing devices. In some of these embodiments, the aural stimulus is delayed from the start of the tactile stimulus within the same event. In these and other embodiments, another event may comprise more than one level of tactile stimulation intensity, where the tactile intensity begins at some level and remains there for the duration of the aural stimulus and then increases at the conclusion of the aural stimulus for the remainder of the event period.

[0141] FIG. 24 shows a graphical depiction of a single ART query cycle as an example of the above embodiments where there is a delayed aural (in this case, a verbal message) stimulus, a second event having two levels of a tactile (in this case, a vibration) stimulus within one event, and pauses between the three events.

[0142] A tactile query initiate device 264 may be included in a set that is placed near a patient's hand or extremity, e.g., leg or foot, is held by a patient in his or her hand and/or is strapped to the patient's hand and/or wrist or extremity. The set may also include a query response device 266. The set may have one or more straps for securing the set to a patient's hand and/or wrist or extremity. A handset may also include attachments not directly involved with the administration of an ART, such as drug dosage request device 254, a pulse oximeter finger probe 314, and/or a wrist or forearm blood pressure cuff 301. A hand cradle device 55 is described below as a particular embodiment of such a handset.

[0143] FIG. 25 and FIG. 26 show alternative embodiments of a handset where the tactile stimulus is produced by a vibrator and the response is directly accepted by a switch that is closed upon the patient squeezing his or her hand around the handset. The vibrating mechanism comprises a motor 2518 and an eccentric weight 2520 attached to the axle of the motor. The vibrating mechanism is housed within an upper casing 2512 and a lower casing 2510. The mechanism is also electrically coupled to the controller 14 via a lead 2516. The controller 14 may send a signal over the lead to activate the vibrating mechanism which creates a tactile stimuli sensible to a patient who holds or is in contact with the handset. The lead 2516 or a different lead connects the controller 14 and at least one switch 2522 that is housed within the handset casings. If more than one switch is used, they are wired in parallel such that closing of any one of the multiple switches is interpreted as a response. The handset may be held by a patient in his or her hand and when he or she squeezes his or her hand, the two casings move towards each other. One or both of the casings 2510 and 2512 are constructed so as to close the switch 2522 when the patient squeezes the handset. When the switch is closed, a signal is sent to the controller 14 which interprets the patient's squeeze as a direct response to the vibratory and/or other stimuli. One or both of the casings may also have a feature 2514 to which a strap may be attached. There may be multiple attachment features 2514 for wrist straps and straps around the back of the hand or forearm, etc. Squeezing the handpiece may produce a tactile and/or audible feedback to inform the patient that the switch has been closed and the stimuli will immediately stop.

[0144] An aural query initiate device 264 may be included in a headset that is placed near or on a patient's head so as to position the stimulus device near the patient's ears. The query initiate device 264 may be an electrical or pneumatic speaker and is connected to an electrical wire or pneumatic tube that transmits an audible stimulus at the direction of the controller 14. There may be single or multiple aural query initiate devices 264 positioned by or near one or both of the patient's ears. The headset may also include a query response device 266 such as a microphone for indirectly capturing the patient's verbal responses to the aural and/or other stimuli. The headset may also include attachments, such as devices for the delivery of oxygen, ventilatory

monitoring, and airway pressure monitoring. An ear clip 450 is described below as an example of such a headset.

[0145] FIG. 27 shows an alternative embodiment of such a headset that comprises a headband 2748 with adjustments 2750 that along with holding plate 2754 secures at least one query initiate device 264 and other attachments to the patient's head. In this particular embodiment, the query initiate devices are speakers 2752 positioned at each of the patient's ears. A gas delivery and sampling module 2740 is provided as an attachment. The delivery and sampling module 2740 is supplied by a hose assembly 2742 which is secured to the headset with at least one hose assembly guide 2756 and is connected to the care system 10 by hose connector 2744 and conduits 2746.

[0146] As described above, the controller 14 may administer an ART query cycle that continues for the duration of a certain number of events and pauses between the events (if the patient fails to respond to the ART) or until the patient responds to one of the events. The controller 14 may further be configured to administer a series of ART query cycles at certain intervals. These intervals may be altered by the clinician and/or by the controller 14 depending on certain conditions regarding the ACQ system 256, the sedation and analgesia system, the ART response times or failures of the patient, and/or the physiology of the patient, among others. In accord with the user interface of the care system 10, a user interface ("UI") may be provided with the ACQ system 256 that allows for the above clinician alterations of ART administration and for the provision of information about the ACQ system 256 to the clinician via the display device 35.

[0147] As part of the UI for the ACQ system 256, an ART On/Off button is provided as a part of the keypad or touchscreen 230. Touchscreen 230 may also be overlaid over the display 35. The clinician may activate automated response testing with this button or ART may be activated as part of an initiation sequence at the start of a sedation and analgesia procedure with which ART is to be a component. Once activated, ART query cycles will be automatically administered to the patient by default at certain normal intervals (e.g., every 3 minutes). An ART Set-up Preferences Display may be provided as part of the visual display 234 (FIG. 18) and is accessible by pressing an ART Set-up button on the UI keypad or by some other button within the UI. The ART Set-up Preferences Display 28200 (FIG. 28) appears upon pressing an ART Set-up button and allows the clinician to change preferences related to ART delivery mode, interval, and language. The clinician may select whether to have the system automatically administer response tests or to prompt the clinician to manually assess patient responsiveness. Under the interval preferences, the clinician may select the interval between ART query cycles and under the language preferences, the clinician may select in what language the system will prompt or query the patient, if verbal auditory stimuli are being used.

[0148] The ACQ system 256 may also automatically present responsiveness tests at a more frequent interval (e.g., every 15 seconds) than the normal interval under certain conditions. The conditions under which the ACQ system 256 may be configured to automatically alter the interval between ART query cycles include situations where prior ART results warrant a retest, where the current drug state is changed, and/or where certain patient physiological condi-

tions exist. The clinician may also call for an immediate ART (“stat ART”) by pressing a button provided with the UI. When the clinician calls for a stat ART, the system resets the timer associated with the interval between ART query cycles and/or turns on the ACQ system **256** if it had not been on when the clinician pressed the stat ART button. The stat ART function also facilitates patient learning of how to give the particular response to ART stimuli by allowing the clinician to initiate a test at any time, even for mere instructional purposes.

[0149] The controller **14** may register an ART response failure upon the patient failing to respond to one ART query cycle during the response period. However, to prevent false unresponsives and to avoid registering failure for situations where the patient was merely distracted for one ART query cycle (rather than being subject to a condition that causes him or her to be unresponsive), the controller **14** may administer a stat ART upon a first ART failure. Therefore, the controller **14** could register either a patient’s first failure or his or her second consecutive failure to respond to an ART as an ART response failure. The controller’s registration of an ART response failure or latency period outside of the stored safety data set is used in its management of other ACQ system **256** or care system **10** functions (e.g., reductions in drug delivery, changes in ART query cycle frequency).

[0150] A portion of the UI display may contain an ART Information Box containing ART Status **2880** and ART History **2878** sections. Within the ART History section **2878**, the ACQ system **256** may display a symbol for the patient’s response to each ART query cycle plotted as the time interval between initiation of a first event of an ART query cycle or initiation of an ART query cycle and the patient’s response to the ART query along the y-axis of a graph versus the time at which each ART query cycle was administered along the x-axis. Patient responses occurring within the response period (e.g., 14 seconds) are displayed as a symbol in one color, e.g. green, on the graph. A patient response that occurs after the response period or a total failure to respond to a test will be displayed as a symbol in another color, e.g. blue. These failed responses may all be displayed on the y-axis at some maximum time on the axis’s scale (e.g., 1 second greater than the allowed response period, 15 seconds in the above example). FIG. 29 shows an example display of an ART History section **2878** where five consecutive ART results were registered by the ACQ system **256** as failures and are all displayed at 15 seconds on the y-axis. Affirmative responses to a prompted manual ART test will always be recorded and displayed at a particular time  $t_{\text{manual}}$  (e.g., 5 seconds). As time progresses, the symbols representing recent ART results will scroll to one side of the ART History section **2878** and will be dropped from the display after they are older than a given elapsed time. The scope of the x-axis (time) scale determines when past ART results will be dropped from the display. The scale exists as a default (e.g., 20 minutes) in the ACQ system **256** but may be changed by the clinician.

[0151] The ART Status section **2880** on the UI display shows the words “Response testing” or “Responsiveness testing” on a green background during the duration of an ART response period or query cycle. The ART Status section **2880** shows a solid fill of a particular color (e.g., green) following a patient response within the response period of

the most recently administered ART query cycle. The ART Status section **2880** shows a background of a different color (e.g., blue) and a relevant message, e.g., “No patient response”, when the patient has not responded within the response period. Also upon a failed ART response, an auditory message may be played to the clinician upon the first failure. The same auditory message may be played upon successive ART failures, but to reduce annoyance and redundant information, it is preferably only played after the system first records an ART response failure. This auditory message may be in the form of a verbal message such as “Loss of Patient Response” or may be another sound suggestive to the clinician that the patient has failed to respond to a query. Should the patient timely respond to a subsequent query but then fail to respond at some later time, the auditory message may again be played. The ART Status section may also display a message when a query is currently being administered. If the clinician has designated the ART mode for a prompted manual check of the patient, a message will be displayed at each normal or altered interval which alerts the clinician to assess the patient’s condition. An audible tone may also be played by the system to prompt the clinician to manually check the patient. The clinician is then to enter his or her assessment of the patient’s responsiveness using the UI in lieu of an actual patient response. If the clinician does not provide information to the system regarding the patient’s responsiveness within a designated time limit, e.g., 45 seconds, the system will assume the patient is non-responsive and may display the above message indicating that there was no patient response received. The response period is longer than the automated query response period because the manual scheme takes into account that the response time of the clinician, that is included in the total response time registered by the system, may be variable and that it will take longer to obtain a response when an intermediary is involved. A clinician entry that the patient is responsive will be recorded at a particular default value (e.g., 5 seconds). The clinician may select to be prompted for manual response tests at an ART Set-up Preferences Display. This manual ART mode capability may be appropriate when the clinician identifies the patient as lacking competency or cooperativeness to follow the procedure of automated responsiveness testing. When the ART has been disabled, an appropriate symbol (e.g., a red “X”) is displayed within the Status section **2880**. FIG. 30 shows examples of each of the ART Status section formats described above.

[0152] The concept of the ART monitor can be combined with the concept of target controlled infusion (“TCI”) of intravenous drugs to increase its safety and effectiveness. When a change is made, either by the clinician or by the controller **14**, from one drug administration state to another (e.g., from drugs off to ramp drugs up) it may be advantageous to administer ART query cycles at more frequent intervals than the normal interval so as to attain the most current assessment of patient responsiveness in as close to real time as possible because the effect site concentration of the drug may be changing rapidly. The sedation and analgesia administration system **10** may be configured so that any time an ART response failure is registered by the ACQ system **256**, the drug state is automatically changed, for example, to a slow ramp down of the effect site concentration. The clinician has an opportunity to override the automated ramp down procedure in certain cases. If the patient regains responsiveness to subsequent ART query cycles after

a registered ART failure, the ART Status section **2880** may show a relevant message and any automated ramp down of drug level will continue unless the targeted effect site concentration is leveled off or otherwise changed by the clinician. If the clinician turns the ACQ system **256** off while the sedation and analgesia administration system is still in a ramp down state because of the patient's failure to respond to a previous query, the administration system continues the ramp down unless the clinician resets or levels off the targeted effect site concentration.

[**0153**] The patient interface system of **FIG. 11** also includes a drug dosage request device **254** which allows the patient direct control of drug dosage. This is accomplished by the patient activating a switch or button to request electronic controller **14** to command the increase or decrease in the amount of drug he or she is receiving. For example, if a patient experiences increased pain he or she may activate the increase portion of the switch **254**, whereas, if a patient begins to feel nauseous, disoriented or otherwise uncomfortable, he or she may request a decrease in drug dosage. In embodiments where drug delivery is intravenous, such delivery can be by continuous infusion or bolus. A feedback signal from analgesic request **254** representing the patient's increase or decrease in drug dosage request is electronically communicated to controller **14** which employs conservative, decision-making software, including comparison of monitored patient conditions with stored safety parameters reflecting patient physiological conditions, to effect safe, optimized drug delivery in response to patient requests. The amount of increase or decrease administered by controller **14** can be pre-set by the physician through user access devices such as keyboard **230**, **FIG. 2**. For example, where the drug being delivered is nitrous oxide, the approved increase or decrease may be in increments of  $\pm 10\%$ . When not activated by the patient, drug request device **254** remains in a neutral position. The invention thus integrates and correlates patient-controlled drug delivery with electronic monitoring of patient physiological conditions.

[**0154**] In an alternative embodiment, the physician is notified via user interface system **16** (display device **30** or LEDs remote control device **45**), **FIG. 1** of the patient request to increase or decrease drug dosage and can approve the requested increase or decrease taking into account the patient's present vital signs and other monitored physiological conditions, including consciousness level status as obtained from the various patient interface system monitors **252**, **256** (**FIG. 11**).

[**0155**] In a preferred embodiment of the invention, the patient controlled drug dosage request system **254** has lock-out capabilities that prevent patient self-administration of drugs under certain circumstances. For example, access to self-administration will be prevented by electronic controller **14** under circumstances where patient physiology parameters or machine state parameters are or are predicted to be outside of the stored safety data set parameters. Access to self-administration of drugs could also be inhibited at certain target levels or predicted target levels of drugs or combined levels of drugs. For example, if it were predicted that the combined effect of requested drugs would be too great, drug delivery in response to patient requests would be prohibited. It is noted that such predictive effects of drugs could be determined through the use of various mathematical modeling, expert system type analysis or neural networks,

among other applications. In short, the invention is designed to dynamically change drug administration and amount variables as a function of patient physiology, care system state and predictive elements of patient physiology.

[**0156**] Additionally, it is contemplated that patient self-administration of drugs could be prohibited at times when drug levels are changing rapidly. For example, if a patient is experiencing pain and that is apparent to the physician, the physician may increase the target level of drug while at the same time the patient requests additional drug. The subject invention will sequentially address the physician and patient requests for drug increases and will lock out any patient-requested increases that are beyond programmed parameters.

[**0157**] In an additional aspect of the invention, a patient may be stimulated or reminded to administer drugs based on electronic feedback from the patient physiology monitoring systems. For example, if there is an underdosing of analgesics and the patient is suffering pain evidenced by a high respiratory rate or high blood pressure reflected in electronic feedbacks to the electronic controller, the controller can prompt the patient to self-administer an increase in drugs. This could be accomplished by, for example, an audio suggestion in the patient's ear. Thus, it is contemplated that the invention will have an anticipatory function where it will anticipate the patient's needs for increased drugs.

[**0158**] In a preferred embodiment of the invention, one or more patient vital sign monitoring devices **252**, ACQ system devices **256**, and a drug dosage request device **254** are mechanically integrated in a cradle or gauntlet device **55** (**FIG. 2**) constructed to accommodate and otherwise fit around a patient's hand and wrist. **FIG. 2** shows generally hand cradle device **55** electronically coupled by lead **50** to care system **10**. One embodiment of a hand cradle device in accordance with this invention is shown in more detail in **FIGS. 12A and 12B**.

[**0159**] **FIG. 12A** shows blood pressure cuff **301** capable of being wrapped around a patient's wrist and affixed to itself such that it can be held in place. Cuff **301** is affixed to palm support portion **303**. Alternatively, the cuff may be separated from palm support portion **303** and placed on the upper arm at the physician's discretion. A recessed, generally elliptical or rounded portion **305** is supported by the top edge of palm support portion **303** and is capable of receiving and supporting the bottom surface of a patient's thumb. Depressible query response switch **307** is located within thumb support portion **305** such that switch **307** is capable of being depressed by the patient's thumb. The thumb support portion **305** may be constructed so as to have a housing, frame, raised walls or other guide so that a patient's thumb may more easily be guided to depress or move buttons or switches within portion **305** (here, switch **307**), or so that any significant patient thumb movement toward the switch will activate same. Supporting thumb support portion **305** and abutting palm portion **303** is finger support portion **309** for receiving in a wrapable fashion the patient's fingers. Drug dosage request switch **311** is integrated into finger support portion **309** and is in the form of a rocker switch whereby depressing the top portion **310a** of said switch will effect an increase in the delivery of sedative, analgesic and/or amestic whereas depressing the bottom portion **310b** of said rocker switch will effect a decrease in drug delivery

at an appropriate set percentage (e.g., 10%, FIG. 12B). Rocker switch 311 is constructed so as to remain in a neutral position when not being actuated by the patient.

[0160] FIGS. 13A and 13B show an additional embodiment of the hand cradle device of this invention. Specifically, a pulse oximetry sensor 314 is mechanically affixed to and electronically coupled to hand cradle device 55 abutting the upper end of finger support portion 309, and being generally planar vis-a-vis the outer edge of thumb support portion 305. Pulse oximeter 314 is constructed as a clip which can be placed on a patient's finger. The transmitter and receiver portions of sensor 314 are contained in the opposite sides 315a, 315b (FIG. 13B) of the finger clip 314 such that when placed on a finger, infra-red radiation travels through the finger; through spectral analysis the percentage of oxygenated hemoglobin molecules is determined. In this embodiment of hand cradle device 55 the query initiate device 313 is in the form of a small vibrator located in palm support portion 303. Alternatively, to enhance patient attentiveness to the query initiate device and to increase patient accuracy in depressing the response switch, the vibrator may be located adjacent the query response switch 307 or, in the embodiment of FIG. 14A, adjacent response switch 407.

[0161] In an alternative embodiment of hand cradle device 55, now referring to FIGS. 14A and 14B, drug dosage request device 409 is located within thumb portion 405 and is in the form of a slidable member 409 wherein sliding member 409 forward effects an increase in analgesic dosage and sliding portion 409 backward effects a decrease in analgesic dosage (FIG. 14B). In this embodiment of the invention, query response device 407 is a depressible portion integrated within finger support portion 409.

[0162] All embodiments of hand cradle device 55 are constructed so as to be ambidextrous in nature, namely, they accommodate and are workable by a patient's right or left hand. For example, in FIGS. 12A and 13A, a second query response switch 307b is located within a symmetrically opposed thumb portion 305b affixed to the opposite end of finger portion 309. Similarly the device of FIG. 14A is also constructed with a symmetrically opposed thumb portion 405b and drug dosage request device 409b. The pulse oximeter clip 314 is affixed to finger support portion 309 so as to be mechanically and electronically quick releasable to permit reversibility when used on the opposite hand. It should also be recognized that the pulse oximeter clip 314 may be tethered to hand cradle device 55 rather than mechanically affixed thereto, or blood pressure cuff 301 and oximeter clip 314 may be mechanically separate from cradle device 55 and electronically coupled to controller 14 with flexible leads.

[0163] Referring to FIG. 15, an additional alternative embodiment of the invention is shown in which hand cradle device 55 includes mechanically integrated blood pressure cuff 301, query response device 307 and analgesic request device 309 similar to that described above. This embodiment, however, includes an ear clip device 450 capable of being clipped to the lobe of a patient's ear and being electronically coupled to electronic controller 14 via lead 456. Referring additionally to FIG. 16, ear clip 450 comprises a query initiate device 452 in the form of a speaker which provides an audible command to patient to activate the response switch. Such speaker may also command a

patient to self-administer drugs or play music to a patient during a procedure. Pulse oximeter 454 is a clip capable of being affixed to a patient's ear lobe. One side of the clip being a transmitter and the other side of the clip being a receiver to effect the infra-red spectral analysis of the level of oxygen saturation in the patient's blood.

[0164] In an additional aspect of the invention, it is contemplated that the care system's automated monitoring of one patient health conditions is synchronized with the monitoring of one or more other patient health conditions. For example, in a preferred embodiment, if the controller 14, receives low O<sub>2</sub> saturation, low heart rate or a low perfusion index feedback information from the pulse oximeter (e.g., the actual parameter received is in the undesirable range of the stored safety data set for those parameters), such feedback will trigger controller 14 to automatically inflate the blood pressure cuff and check the patient's blood pressure. (This is because low O<sub>2</sub> saturation can be caused by low blood pressure; and low heart rate can cause low blood pressure and vice versa, etc.) Therefore, under normal operating conditions the preferred embodiment of the invention will automatically check the patient blood pressure every 3 to 5 minutes, and whenever there is a change in other patient parameters such as blood O<sub>2</sub> saturation or heart rate. In another example, the electronic checking of blood pressure is synchronized with the automated consciousness query because the activation of the cuff may arouse a patient and affect query response times. Thus the invention contemplates an "orthogonal redundancy" among patient health monitors to ensure maximum safety and effectiveness.

[0165] As described above, one aspect of a preferred embodiment of the invention includes the electronic management of drug delivery via software/logic controlled electronic controller 14 to integrate and correlate drug delivery with electronic feedback signals from system monitors, one or more patient monitor/interface devices and/or user interface devices. Specifically, electronic signal values are obtained from care system state monitors; from patient monitor/interface devices (which can include one or more vital sign or other patient health monitors 252, ACQ system 256, and/or patient drug dosage request device 254, FIG. 11); and in some instances from one or more user interface devices. All are electronically coupled to, through standard A-D converters where appropriate, electronic controller 14. The controller 14 receives the feedback signal values and, via software and programmed logic, effects a comparison of these values representing the patient's monitored physiological conditions with known stored data parameters representing safe and undesirable patient physiological conditions (a safety data set). Controller 14 then generates an instruction in response thereto to maintain or decrease the level of sedation, analgesia, and/or amnesia being provided to the conscious patient thereby managing and correlating drug delivery to safe, cost-effective and optimized values (FIG. 2B. Controller 14 is operatively, electronically coupled to electronic flow controllers 133, 135 (FIG. 8) of electronic mixer 44 which (via solenoid valves) adjust flow of gaseous drug and O<sub>2</sub> in a closed-loop fashion as described above. In intravenous embodiments such flow controllers would adjust the flow of one or more combination of IV drugs. It should be recognized that the electronic values provided to microprocessor controller 14 to effect management and correlation of drug delivery, could include one or more signals representing patient vital signs and other health

conditions such as pulse oximetry, without necessarily including signal(s) representing level of patient consciousness, and vice versa.

[0166] As also indicated above, the software effecting electronic management of drug delivery by controller 14 employs "conservative decision-making" or "negative feedback" principles. This means, for example, that the electronic management of drug delivery essentially only effects an overall maintenance or decrease in drug delivery (and does not increase drugs to achieve overall increased sedation/analgesia). For example, if ACQ system 256 (FIG. 11) indicates a latency period outside of an acceptable range, controller 14 may instruct electronic flow controller 133 (FIG. 8) to increase the flow of oxygen and/or instruct flow controller 135 to decrease the flow of gaseous drug to manifold system 48.

[0167] In another example of such electronic management of drug delivery by conservative decision-making principles, if ACQ system 256 (FIG. 11) indicates a latency period in response to a patient query given every 3 minutes outside of an acceptable range, electronic controller 14 may immediately cease drug delivery, but at the same time, increase the frequency of times that the patient is queried, e.g., to every 15 seconds. When the patient does respond to the query, the drug delivery is reinitiated, but at a lower overall dose such as 20% less than the original concentration of drug that had been provided.

[0168] A further example of the invention's electronic management of drug delivery through conservative, decision-making software instruction employs known target-controlled infusion software routines to calculate an appropriate dosage of IV drug based on patient physical parameters such as age, gender, body weight, height, etc. Here, a practitioner provides the patient physiological parameters through the user interface system, the electronic controller 14 calculates the appropriate drug dosage based on those parameters, and drug delivery begins, for example, as a bolus and is then brought to the pre-calculated target level of infusion. If later there is a significant change in a patient monitored parameter, e.g., pulse oximetry or latency period falls outside of a desired range, controller 14 effects a decrease in overall drug delivery as described above.

[0169] One concern that the invention addresses with respect to the target controlled infusion of IV drugs is the nature and speed at which the care system reaches the steady state target level of drug. For example, an important consideration for the physician is, once drug administration begins, when is the patient sufficiently medicated (e.g., sedated or anesthetized), so that the physician can begin the procedure. It is frequently desirable that the patient reach the steady state target level of drug as rapidly as possible so that the procedure can begin as soon as possible. It has been determined that one way of reaching a suitable level of drug effectiveness quickly is to initially overshoot the ultimate steady state target drug level. This shortens the time between the beginning of drug delivery and the onset of clinical drug effectiveness so that the procedure may begin. Typically, predicted target levels have an error of plus or minus 20%, therefore, one approach of reaching the clinical effectiveness state quickly is to attempt to reach at least 80% of the ultimate target level, but initially overshoot that 80% level by giving a 15% additional increase of drug infusion beyond

the 80% target. One method of accomplishing this is to use currently available PDI controllers which employ an error state (here the difference between predicted drug levels in the blood stream and the target level) to arrive at an infusion rate. Other control systems, however, that allow some initial overshoot of the target blood level of the drug to get to a clinical effectiveness level quicker would also be appropriate.

[0170] ACQ system 256 allows a clinician to find that effect site concentration of drug at which a patient loses responsiveness in an automated manner. To find that effect site concentration, the clinician initiates a ramp up of the effect site concentration and waits for the ACQ system 256 to register a failure of ART response. The effect site concentration, as predicted by a TCI algorithm, at the time the controller registers ART response failure may be considered by the clinician to be indicative of the effect site concentration of drug for the intended procedure. In a particular embodiment, taking the above features of the ACQ system 256 into account, ART queries are administered to the patient every 15 seconds during the ramp up drug state. At some point along the increasing drug effect site concentration curve, the sedative and/or analgesic causes the patient to lose responsiveness. It is at this point that the clinician can accurately calibrate the calculated effect site concentration of sedative drug to the patient's response. The ACQ system 256 may be configured to automatically signal the drug administration system to level off the drug effect site concentration or the clinician may manually stop the effect site concentration ramp up and level off the effect site concentration being administered. The clinician may then perform the medical procedure while the drug effect site concentration is maintained at this effect site concentration target, or the effect site concentration may be further adjusted based on the patient's response to the procedure and anticipated changes in pain level during a procedure. At the end of the procedure, the clinician may then turn off the drug infusion pump and conclude the case.

[0171] In alternative embodiments, the clinician may make guesses at what effect site concentration would produce unresponsiveness for the procedure for a given patient with a given drug. The clinician could start the drug effect site concentration to that guessed level, wait, and then assess the patient's condition, including responsiveness, for signs that it is wise to begin the medical procedure. If the clinician's guess is too low, he or she will have to start drugs to another higher effect site concentration and wait and observe again. Because it is safer for the clinician to undershoot the effect site concentration at which the patient loses responsiveness rather than overshoot it, he or she may spend much time with this sort of trial and error approach to finding the ideal steady state effect site concentration at which to perform the procedure. By automating the process of finding the effect site concentration at which the patient loses responsiveness with the ACQ system 256, the clinician is freed up to manage other pre-procedural activities.

[0172] Other useful information provided by the ACQ system 256 comes from the progression of response times during the response window (i.e., 14 seconds) of events and pauses. The response times vary by some function of the current drug effect site concentration. As the drug effect site concentration increases and the patient approaches the point at which he or she loses responsiveness, his or her response

times will begin to increase along some curve. The ACQ system 256 can make use of this curve and/or a mathematical model derived from it when matched or correlated against the curve of increasing drug effect site concentrations. Among possible uses are prediction of the drug effect site concentration at which the patient will lose responsiveness. This ability allows the use of more aggressive ramp-ups in drug effect site concentration and/or leveling off of the drug effect site concentration before actual loss of responsiveness to minimize effect site concentration overshoots. The ACQ system 256 may communicate the response time progression curve to the system administering drugs so that the drug system may change the current drug state based on the curve. The ACQ system 256 may also display a message to the clinician via the UI regarding the fact that the patient's response times are exhibiting a progression curve with a particular function. The clinician may then make his or her own decision about whether to alter the drug state prior to the patient losing responsiveness altogether.

[0173] Under the above circumstances, ART results provide useful information prior to the beginning of a procedure. The ART queries may be continued throughout the duration of a procedure and upon a change to a ramp down or off drug state at procedure's end. The clinician or the drug administration system may also make use of the information the ACQ system 256 provides during these periods, such as the time and drug effect site concentration at which the patient regains responsiveness and has timely responses to ART again.

[0174] The intervals between ART query cycles may also be modified by the ACQ system 256 during situations where certain patient state parameters (e.g., low SpO<sub>2</sub>, low heart rate, low blood pressure, or low respiration rate) have reached pre-specified alarm limits. These parameters may be monitored and the alarms assessed by the controller 14 of any larger system the ACQ system 256 is coupled with. These ART results may then serve as a basis for comparison to or checks of the assessments made by the clinician or the larger system controller 14 regarding the patient state alarms.

[0175] ACQ system 256 may also be used to promote amnesia by titrating drugs until the patient is unresponsive according to ART results. For example, if a clinician anticipates that a procedure will result in painful episodes for patient, user may select to ramp drugs up until an ESC is reached that results in an ART response failure by the patient. Thus, the clinician may deliberately cause loss of responsiveness during painful episodes to promote amnesia and blunt recollection of the painful episodes.

[0176] FIG. 17 is a schematic of an alternative embodiment of an apparatus constructed in accordance with the invention which is particularly suitable for remote medical care locations and home care-type settings for indications such as post-operative or other post-procedural pain and/or discomfort, including, for example, nausea secondary to oncology chemotherapy. In this embodiment, drug source system 442 delivers drugs to the patient (which may be drugs such as propofol, morphine, remifentanyl and others) intravenously by, for example, use of a known syringe pump-type device capable of being worn or otherwise affixed to the patient, or delivers such drugs transdermally by, for example, use of known ion transfer-type devices,

among others. The drug delivery may be continuous or by drug bolus and without an integrated supply of O<sub>2</sub>. If necessary, oxygen may be supplied to the patient from separate tanks or an in-house, on-site oxygen source. The resulting apparatus is simplified—there is no requirement for an integrated O<sub>2</sub> source, electronic mixer, manifold, or the airway circuit and face mask devices described above.

[0177] One or more patient health monitors 412 such as known pulse oximeters, blood pressure cuffs, CO<sub>2</sub> end tidal monitors, EKG, and/or consciousness monitors, or other monitors such as those indicated herein, monitor the patient's physiological condition. Drug dosage may be pre-set by a physician prior to or during application of drug delivery and/or also patient controlled thereafter by means of a patient drug dosage increase or decrease request devices generally of the type of that described above. It should also be understood that the intravenous delivery of drugs may be by continuous infusion, target-controlled infusion, pure bolus, patient-elected bolus or combinations thereof.

[0178] Still referring to FIG. 17, electronic management of drug delivery in this embodiment of the invention is provided by electronic controller 414 which may be of a type described above. Controller 414 employs conservative decision-making software and/or logic devices to integrate and correlate drug delivery by drug source system 442 (which may include known solenoid type or other electronic flow controllers) with electronic feedback values from one or more patient health monitors 412. The values (signals) from patient health monitors 412 represent one or more actual patient monitored physiological conditions. Controller 414, through software employing comparison protocols such as those described herein, accesses stored safety data set 410 which contains data reflecting safe and undesirable patient physiological conditions, and compares the signals reflecting actual patient monitored conditions with same. As described above, safety data set 410 may be stored in a memory device such as an EPROM. Based on the result of the comparison, controller 414 either instructs no change in drug delivery or generates a signal instructing the drug flow controllers of drug source system 442 to manage application of the drug to safe, optimized levels.

[0179] In certain aspects of the invention, controller 414 may also access, through software, pre-set parameters stored in a memory device representing initial or target drug dosages and lock-outs of patient drug administration requests as described above. In these circumstances, instruction signals generated by controller 414 would also account for and control drug delivery in accord with these pre-set parameters.

[0180] This embodiment of the invention would also typically include system state monitors, such as electronic sensors which indicate whether power is being supplied to the system or which measure the flow of drugs being delivered. Such system state monitors are electronically coupled to controller 414 and provide feedback signals to same—the control of drug delivery by controller 414 electronically coupled to drug source system 442 in response to said feedback signals is similar to that as described herein with respect to other embodiments.

[0181] In another aspect of the invention, electronic controller 414 is located on a remote computer system and electronically manages on-site drug delivery integrating and

correlating same with on-site monitoring of patient physiological conditions and care system states as described above, but here with instructions signals generated from a remote location. It is contemplated that controller 414 may, in some embodiments, effect transmission via modem or electronic pager or cellular-type or other wired or wireless technologies of electronic alarm alerts to remote locations if a monitored patient parameter such as the percentage of oxygen absorbed into the blood ( $\text{SpO}_2$ ) falls outside of a safe established value or range of values as established by the stored safety data set. Such remote locations could thereby summon an ambulance or other trained caregiver to respond to the alarm alert.

[0182] FIG. 18 details the user interface system of a preferred embodiment of the invention. This system enables the physician to safely and efficaciously deliver one or more of sedation, analgesia or amnesia to a patient while concurrently performing multiple tasks. The user interface permits the physician to interact with the care system and informs the user of the patient's and system's status in passive display devices and a variety of active audio/visual alarms thereby enhancing the safety and enabling immediate response time (including the "conservative" responses, e.g., detailed drug delivery discussed above) to abnormal situations.

[0183] Specifically, a keypad and/or touch screen 230 (FIGS. 2 and 18) allows the physician to interact with electronic controller 14, inputting patient background and setting drug delivery and oxygen levels. A remote control device 45 (FIGS. 1 and 18) provides the physician with remote interaction with the care system 10 allowing him or her to remotely control the functions of the system. Remote control device 45 may be removably integrated into the top surface of housing 15 and capable of being clipped onto material close to the physician and/or patient. In one aspect of the invention, the remote control device 45 itself contains display devices such as LEDs to advise the physician of patient and system parameters. A panic switch 232 (FIG. 18), which may be on-board housing 15 (FIG. 1) or contained in remote control device 45 and electronically coupled to controller 14 allows the physician to shut down care system 10 and maintains it in a safe state pre-programmed into controller 14.

[0184] Visual display devices 234 (FIG. 2, 35) display actual and predictive or target patient and system parameters and the overall operation status of the care system.

[0185] One version of a preferred embodiment of visual display 234 is shown in FIG. 22A.

[0186] The display 2230 includes a first portion of the display 2234 which is devoted to displaying to the user the current status of the system operation and monitored patient conditions, including the status of any alarm caused by a change in monitored system or patient condition. For example, if a patient's timed response to a consciousness query (latency period) is outside an established range and an alarm is thus activated, that query latency period is displayed in this first portion 2234 of the visual display, thereby enabling the physician to immediately understand the cause of the alarm.

[0187] The visual display device 2230 of this embodiment also includes a second portion of the display 2236 which is

devoted to displaying the actions taken or soon to be taken by the care system. For example, if in response to an alarm indicating a latency period outside of an established safe range the apparatus will decrease the flow of drug to the patient, this second portion 2236 displays the percentage decrease in drug dosage to be effected.

[0188] Visual display 2230 facilitates the physician's interaction with the apparatus by walking the physician through various system operation software subprograms. Such subprograms may include system start-up where a variety of system self-checks are run to ensure that the system is fully functional; and a patient set-up. To begin the procedure, the care system monitors are placed on the patient and the physician activates the system by turning it on and entering a user ID (it is contemplated that such user ID would only be issued to physicians who are trained and credentialed). Next, the visual display would prompt the physician to begin a pre-op assessment, including inputting patient ID information and taking a patient history and/or physical. In the pre-op assessment, the physician poses to the patient a series of questions aimed at determining appropriate drug dosage amounts (such as age, weight, height and gender), including factors indicative of illness or high sensitivity to drugs. The responses to such questions would be inputted into the care system and employed by the system to assist the physician in selecting the appropriate dose amount. For example, the care system may make available to the physician one range of dosage units for a healthy person and a narrower range of dosage units for a sick or older person. The physician would have to make an explicit decision to go above the recommended range. In addition to the pre-op assessment performed by the physician described above, it is also contemplated that the care system is capable of performing an automated pre-op assessment of the patient's physiology. For example, with the monitors in place, the care system will assess such parameters as the oxygenation function of the patient's lungs and/or the ventilatory function of the patient's lungs. The oxygenation function could be determined, for example, by considering the A-a gradient, namely, the alveolar or lung level of oxygen compared to the arteriolar or blood level of oxygen. The ventilatory function of the lungs could be determined from pulmonary function tests (PFTs), among other things, which are measurements of the amount of air and the pressure at which that air is moved in and out of the lungs with each breath or on a minute basis. (It is contemplated that these assessments are performed before the procedure begins and during the procedure as a dynamic intra-operative assessment as well.) Also during the pre-op (or as a continuous intra-operative) assessment, heart function may be assessed by viewing the output of an EKG to determine whether there is evidence of ischemia or arrhythmias. Alternatively, automated algorithms could be applied to the EKG signals to diagnose ischemia or arrhythmias. Additional automated patient health assessments could also be made.

[0189] During patient set-up, current patient and system parameters may also be assessed and displayed, and the consciousness-query system and patient drug increase/decrease system tested and baselined. A set drug subprogram allow for the selection of drugs and/or mixture of drugs (or drug, oxygen and air), allows for picking target levels of drugs, and/or permits enabling of the patient's self-administration of drugs within certain ranges. The invention also

contemplates during the pre-op assessment determining a sedation threshold limit for the given patient in the unstimulated state. This could be done as a manual check, i.e., by simply turning up the drug levels and watching the patient manually or the procedure could be automated where the drugs are increased and the safety set parameters such as those for latency (consciousness queries) are tested as the concentration at the drug effect site is increased.

[0190] The system and patient status and system action may be displayed during, for example, a sedation subprogram. Visual display device 2230 may include graphical and numeric representations of patient monitored conditions such as patient respiratory and ventilatory status, consciousness, blood O<sub>2</sub> saturation, heart rate and blood pressure (2238); an indication of elapsed time from the start of drug delivery (2239); drug and/or O<sub>2</sub> concentrations (2241); and indications of patient requests for increases or decreases in drug (2243). The actual fraction of inspired oxygen calculated may also be displayed. Command "buttons" are included to mute alarms (2240), change concentration of drug delivered (2242), turn on or off the mixing of an oxygen stream with atmospheric air (2244), and to turn on or off or make other changes to the automated consciousness query system (2246). Command buttons may also be included to place the apparatus in a "recovery" mode once the procedure is completed (patient parameters are monitored, but drug delivery is disabled) (2248), and to end the case and start a new case (2250) or shut-down the system.

[0191] An alternate version of a preferred embodiment of the visual display portion of the invention is shown in FIG. 22B. Portions 2202, 2204, 2206 and 2208 of display device 2200 show current patient O<sub>2</sub> saturation, blood pressure, heart rate, and end tidal CO<sub>2</sub> levels, respectively. These portions displaying patient physiological state are uniquely color coded. Smart alarm box portion 2212 which may be coded in an attention getting color such as red, displays to the physician the particular alarm that has sounded. For example, if the patient O<sub>2</sub> blood saturation level falls below safe levels, the O<sub>2</sub> saturation alarm will sound and the O<sub>2</sub> saturation level will appear in smart alarm box portion 2212 where it can be easily seen by the physician. In short, whatever parameter has alarmed is moved to the smart alarm box portion; the specific alarm indicator is moved to the same place every time an alarm sounds. Also, the level of criticality of the alarm which, as described below, in a preferred embodiment may be indicated by either yellow or red color, is displayed in the patient physiological parameter portion of the display. For example, if a red level O<sub>2</sub> saturation alarm sounds, the background portion of the O<sub>2</sub> saturation portion 2202 will appear in red.

[0192] Portion 2214 of display 2200 shows the past, present and predicted levels (2215) of drug administration (the drug levels shown in FIG. 22B are the levels of nitrous oxide remifentanyl and propofol). In a preferred embodiment target controlled infusion past, present and predicted levels are shown graphically beginning with the past thirty minutes and going thirty minutes into the future. The invention also contemplates bracketing a range of accuracy of target controlled infusion levels (not shown).

[0193] Display portions 2220 and 2224 depict graphical representations of patient health parameters such as the A-a

gradient (oxygenation function) for the lungs, the results of pulmonary function tests, electrocardiogram, blood O<sub>2</sub> saturation, among others.

[0194] In another aspect of the invention, visual display 35 (FIG. 1) may be removably integrated into the top surface of housing 15 and capable of being removed from housing 15 and affixed to a frame near the patient, such as a gurney rail or examination table. Alternatively, or in addition thereto, a heads-up type visual display device is provided to facilitate a nonanesthetist's involvement in the medical or surgical procedure while simultaneously being able to view the status of system and patient monitored values and the details of alarm states. In this case, the display device is miniaturized and mounted onto a wearable headset or eyeglass-type mount or mounted on an easily viewed wall display.

[0195] Referring again to FIG. 18, in a preferred embodiment, audible alarms 236 alert the physician when patient or system parameters are outside of the normal range. In preferred embodiments, the alarms may be two or three stages with different tones to indicate different levels of concern or criticality. As is described above, when an alarm sounds, the user is able to immediately view the cause of the alarm because the smart alarm box portion 2212 of the visual display 2200 shows the value of the monitored system or patient parameter that caused the alarm to activate.

[0196] FIG. 21A shows examples of drug delivery management protocols for three-stage alarms responsive to patient monitors, namely, alarms "1," "2" and "3," in accordance with a preferred embodiment of one aspect of the invention. These alarms may have different tones or other indicators to denote different levels of concern or criticality. The dataflow diagram of FIG. 23A depicts one example of the steps performed by the drug delivery managing software or logic for one such protocol, namely, one where electronic controller 14 described above receives an electronic feedback signal from a pulse oximeter monitoring the actual amount of oxygen saturation in a patient's blood (the value indicated by "SpO<sub>2</sub>"). As is shown, the SpO<sub>2</sub> value is compared with stored safety data set 220 containing a parameter value or range of parameters values reflecting safe and undesirable patient blood oxygen saturation conditions. If the SpO<sub>2</sub> value is greater than or equal to stored parameter 90%, no alarm sounds and no adjustment to drug delivery is effected (221a). If the SpO<sub>2</sub> value is less than 90%, but greater than 85% (221b), alarm 1 sounds for 15 seconds (222). If alarm 1 is silenced manually (222a), no further action is taken by the system. If alarm 1 is not silenced, the amount of drug being delivered (in this example gaseous N<sub>2</sub>O) is reduced to the lesser of a concentration of 45% or the current concentration minus 10% (223). The software/ logic procedure would operate in a similar fashion for intravenous and nebulized forms of drugs and the instructions provided (e.g., as in 223) would be specified for safe dosages of such drugs.

[0197] Further, if the value of oxygen saturation (SpO<sub>2</sub>) is less than 85%, but greater than or equal to 80% (221c), alarm 2 sounds and the amount of N<sub>2</sub>O being delivered is immediately reduced to the lesser of a concentration of 45% or the current concentration minus 10% (224). If the feedback value SpO<sub>2</sub> from the pulse oximeter indicates that the oxygen saturation in the blood is less than 80%, alarm 3

sounds and the amount of N<sub>2</sub>O being delivered would be immediately reduced to 0% (225).

[0198] Similar protocols are described in FIG. 21A for electronic feedback signals from patient health monitors indicating pulse rate, amount of carbon dioxide in a patient's end tidal exhalations, respiration rate, systolic blood pressure, and feedback from the automated consciousness monitoring system constructed in accordance with the invention. These protocols are effected with software (and/or logic) operating in similar fashion to that described in the dataflow diagram of FIG. 23A. That is, the protocol shown in FIG. 23A is one example employing one patient monitored parameter, but the operation of the invention would be similar to effect the remaining protocols of FIG. 21A.

[0199] It should be understood that the system responses to alarms (described above in terms of decreases or cessation of drug concentration) could also include institution and/or increases in administration of oxygen in accord with patient and system state parameters as described above. In circumstances where drugs are halted and pure oxygen (or an O<sub>2</sub> atmospheric mix) is provided, e.g., where feedback signals indicate the patient has a low blood O<sub>2</sub> saturation, a preferred system is designed to operate in a LIFO ("last-in-first-out") manner. This means that when controller 14 receives feedback signaling an adverse patient or machine state and instructs flow controllers to turn on the oxygen, the very next breath the patient takes will be of pure O<sub>2</sub> (and/or atmospheric air) rather than of a drug/air mixture. This may be accomplished, for example, by supplying O<sub>2</sub> for air directly to PIV 152 (FIG. 9A) and bypassing reservoir bag 149.

[0200] FIG. 21B shows examples of drug delivery management protocols for two-stage alarms responsive to system state monitors, namely, alarms "1" and "2," in accordance with a preferred embodiment of one aspect of the invention. The alarms may have different tones or other indicators to note different levels of concern or criticality. The dataflow diagram of FIG. 23B depicts one example of the steps performed by the drug delivery managing software and/or logic for one such protocol, namely, one where electronic controller 14 (e.g., FIG. 2A) receives an electronic feedback value from an O<sub>2</sub> tank pressure sensor (519) indirectly measuring the amount of oxygen remaining in an on-board oxygen tank (the value indicated by "O<sub>2</sub> remaining"). As is shown, the O<sub>2</sub> remaining value is compared with an established data set of safe system parameters stored in a memory device as described above, said data set containing a "setpoint" reflecting known safe and undesirable oxygen tank pressure conditions (520). If the oxygen pressure is greater than the setpoint, no alarm sounds and no adjustment to drug delivery is effected (521). If the O<sub>2</sub>% value is less than the setpoint, alarm "1" sounds (522). If alarm "1" is silenced manually within 15 seconds, no further action is taken by the system (523). If alarm "1" is not silenced within 15 seconds, the amount of drug being delivered (in this example gaseous N<sub>2</sub>O) is reduced to the lesser of the concentration of 45% or the current concentration minus 10% (524). The software or logic procedure would operate in a similar fashion for intravenous and nebulized forms of drugs and the instructions provided (e.g., as in 524), would be specified for safe dosages of such drugs.

[0201] In another example of FIG. 21B involving a system state monitor which indicates whether power is being

supplied to apparatus 10, a logic operation determines whether power has been interrupted. If the system state monitor for power signals that power has been interrupted, alarm "2" sounds and the delivery of drug is reduced to 0%.

[0202] Similar protocols are described in FIG. 21B for system state monitors indicating O<sub>2</sub> interruption fail safe, total gas flow, drug tank pressure, fraction of inspired oxygen (FIO<sub>2</sub>), and operation of the vacuum pump for scavenging system 48 (FIG. 6). These protocols are effected with software (and/or logic) operating in similar fashion to that described in the dataflow diagram of FIG. 23B. That is, the protocol shown in FIG. 23B is one example employing one system state monitor stored parameters, but the operation would be similar to effect the remaining protocols of FIG. 21B.

[0203] In the above examples, involving response to patient physiological state, there is a time lapse between the alarm's sounding and any decrease in drug delivery to the patient. In alternate protocols contemplated by the invention, electronic controller 14 will immediately cease or curtail drug administration upon the sounding of an alarm. For less critical ("yellow") alarms, drug delivery may be decreased to 80% levels upon the sounding of the alarm; for more critical ("red") alarms, drug delivery would cease upon the sounding of the alarm. In either case, the physician will then be given time, for example, thirty seconds, to instruct controller 14 to restart the drug delivery (e.g., the physician will need to override the curtailing of drug delivery). If the physician does override controller 14, drugs are reinitiated, for example, by a bolus amount. This method prevents against a patient's deteriorating while a physician waits to respond to an alarm at current drug levels, and also avoids underdosing by permitting the physician sufficient time to reinitiate drug delivery.

[0204] Referring again to FIGS. 2 and 18, a printer 238 (FIG. 2, 37) provides an on-site hard copy of monitored patient health parameters (e.g., the feedback values from the one or more patient health monitors), as well as alarm states with time stamps indicating which type of alarms sounded, why and when. Diagnostic LEDs 240 affixed to the exterior of apparatus 10 (e.g., FIG. 1) and electronically coupled to controller 14 permit the physician typically involved in the procedure to ascertain system states at a glance; LEDs coupled to microprocessor controller 14 also permit service technicians to assess fault states.

[0205] A preferred embodiment of the invention includes a variety of peripheral electronic devices, one group internal to or integrated within housing 15 of apparatus 10 (e.g., FIG. 1) and a second group on-board electronic controller 14. These electronic devices ensure proper operation of various aspects of system 10, including providing hardware status feedback through sensors to ensure that the apparatus is operating within its desired parameters. FIGS. 19A and 19B describe various peripheral devices in accordance with the invention, such devices may be of a known, off-the-shelf types currently available. Specifically, internal solenoid-type activated door locks 190 restrict access to the interior of apparatus 10. Door locks 190 are located within housing 15 (FIG. 1) and are electronically coupled to and controlled by controller 14 by means of software that includes protocols for password protection. Access to the interior of apparatus 10 is thus restricted to authorized personnel with passwords.

This is intended to, among other things, minimize chances of "recreational" abuse of the pharmaceuticals (e.g., N<sub>2</sub>O) contained therein. Internal door status sensors 191 located within housing 15 and electronically coupled to controller 14 generate signals indicating if an access door to the interior of apparatus 10 is open or closed. Real-time clock 192 on-board controller 14 enables said controller 14 to provide time stamps for overall system and patient activities and thereby enables creation of an accurate log of the operation of care system 10. On-board ambient temperature sensor 193 monitors the exterior temperature signaling same to controller 14 which through software comparison type protocols confirms that apparatus 10 is being operated under desired conditions with respect to surrounding temperature. Internal battery temperature sensor 194 located within housing 15 and electronically coupled to controller 14 generates signals to same indicating whether the back-up battery power system is functioning correctly and not overcharging. Tilt sensor 195 located on-board controller 14 signals same if the apparatus 10 is being operated at an angle beyond its designed conditions.

[0206] In a preferred embodiment, the software control processes of electronic controller 14 are stored in a standard flash memory 196 and SRAM type battery-backed memory 197 stores system, patient and other status information in the event of an AC power loss. On-board fault detection processor (FDP) 198 signals failures to controller 14 and is a secondary microprocessor based computing system which relieves controller 14 of its control duties if a fault is detected in operation. On-board watch dog timer 199 indicates to controller 14 that the apparatus 10 is functioning and resets controller 14 if system 10 fails to respond.

[0207] A preferred embodiment of the invention also includes a standard serial port interface, such as an RS-232C serial port, for data transfer to and from electronic controller 14. The port enables, for example, downloading software upgrades to and transfer of system and patient log data from controller 14. An interface such as a PC Type III slot is also provided to enable the addition of computer support devices to system 10, such as modems or a LAN, to be used, for example, to transfer billing information to a remote site; or to permit diagnosis of problems remotely thereby minimizing the time required for trouble-shooting and accounting.

[0208] It should be understood that the care system of the invention may be modular in nature with its functions divided into separable, portable, plug-in type units. For example, electronic controller 14, display devices (FIG. 2, 35) and one or more patient health monitors would be contained in one module, the pneumatic systems (flow controllers, pressure regulators, manifold) in a second module, and the base (FIG. 3B, 17), oxygen and drug tanks (FIG. 2, 54), scavenger system and vacuum pump (FIG. 3B, 32) in a third module. Additionally, the patient health monitors or drug delivery aspects of the system may each be their own plug-in type modules. The system, for example, may provide for a pluggable ventilator type module. This modularity enables the system not only to be more easily portable, but also enables use of certain features of the system (such as certain patient health monitors), while not requiring use of others.

[0209] FIG. 20 depicts a preferred embodiment of a patient information and billing system capable of being

interfaced with care system 10 (FIG. 1) to allow billing or other gathering of patient information to take place locally at the place of use or remotely at a billing office. Specifically, information/billing storage system 280, which may be of a known type microprocessor-based computing system controlled by software, collects and stores patient data 281 such as the patient's name, address and other account information, as well as metered system operation data 282 generated during operation of apparatus 10 and stored in controller 14 such as start time, time of use, frequency of use, duration of patient monitoring, amount of gases expended, and other such parameters. User access device 283 which may be of a standard keyboard type permits the physician to interact with information/billing storage system 280 to input additional data such as pre-determined treatment or billing parameters or to read the status of same (e.g., to read the status of metered system operation parameters 282). Preferably, a password is provided to permit access to information/billing system 280.

[0210] At the termination of a medical or surgical procedure or at some other desired period, information/billing storage system 280 processes the received data and transmits same to revenue/billing processing center 286 at a remote location. Revenue/billing processing center 286 may be of a known, mainframe-type computing system such as that manufactured by International Business Machines (IBM) or a known client-server type computer network system. At the remote location a patient invoice is generated by printer 287 as may be other revenue records used for payment to vendors, etc.

[0211] The invention also contemplates that an automated record of the system operation details will be printed at the user site on printer 285 which is preferably located on-board apparatus 10 (FIG. 1). Such system operation details may include, for example, all alarm and actual system operation states, drug flow rates and/or monitored actual patient physiological conditions as supplied by electronic controller 14. A modem or LAN may be used to send and receive billing and other information remotely and to communicate with remote client/server or other networks 288 as described above.

I claim:

1. A patient monitoring system for monitoring a patient's responsiveness comprising:
  - (a) at least one query initiate device for prompting a response from a patient;
  - (b) at least one query response device for sensing a patient's response to a prompt from the at least one query initiate device; and
  - (c) an electronic controller in communication with the at least one query initiate device and the at least one query response device, wherein said controller generates an assessment of a patient's responsiveness based upon patient's response or lack of response to a prompt from the at least one query initiate device.
2. The patient monitoring system according to claim 1, wherein the electronic controller generates an assessment of a patient's responsiveness based upon a latency period between a prompt by the at least one query initiate device and a patient's response to the prompt.

3. The patient monitoring system according to claim 1, further comprising at least one patient physiological monitor for generating patient health data, wherein the system automatically assesses a patient's responsiveness based upon the patient health data.

4. The patient monitoring system according to claim 3, wherein the at least one patient physiological monitor is selected from the group consisting of a capnometer, a pulse oximeter, an electrocardiography monitor, a blood pressure monitor, a respiration monitor, and an electroencephalography monitor.

5. The patient monitoring system according to claim 1, wherein the at least one query initiate device may be part of a handset or a headset.

6. The patient monitoring system according to claim 5, wherein the at least one query initiate device prompts the patient with a stimuli, wherein the stimuli is of variable intensity, urgency, and duration.

7. The patient monitoring system according to claim 1, wherein the system is integrated with a system for the delivery or monitoring of drugs during a medical procedure.

8. The patient monitoring system according to claim 7, wherein the system for the delivery or monitoring of drugs is clinician controlled, patient controlled, or automated.

9. The patient monitoring system according to claim 7, wherein said drugs are for sedation and analgesia.

10. The patient monitoring system according to claim 7, wherein the system for the delivery or monitoring of drugs during a medical procedure delivers drugs to the patient, wherein the rate of drug delivery is altered based upon the assessment of the patient's responsiveness generated by the electronic controller.

11. The patient monitoring system according to claim 1, wherein a user of the system can manually initiate an automated measurement of patient responsiveness.

12. The patient monitoring system according to claim 1, further comprising a manual responsiveness test function for allowing a user to manually assess patient responsiveness and manually enter the results of the manual assessment into a user interface.

13. The patient monitoring system according to claim 1, further comprising an interface for a user of the system to interact with and monitor the functions of the system.

14. A method for monitoring a patient's responsiveness comprising the steps of:

- (a) querying a patient with at least one stimulus;
- (b) sensing a patient's response to the at least one stimulus or noting the lack of a patient's response within a pre-determined amount of time after the initiation of the at least one stimulus; and
- (c) assessing the patient's level of responsiveness based upon the step of sensing a patient's response or noting the lack of a patient's response.

15. The method for monitoring a patient's responsiveness according to claim 14, wherein the at least one stimulus comprises one or more of tactile, aural, and visual stimuli.

16. The method for monitoring a patient's responsiveness according to claim 14, further comprising the step of displaying the assessed responsiveness of the patient via an interface device to a clinician attending to the patient.

17. The method for monitoring a patient's responsiveness according to claim 14, further comprising the step of que-

rying the patient with a subsequent at least one stimulus a pre-determined amount of time after a first at least one stimulus.

18. The method for monitoring a patient's responsiveness according to claim 17, further comprising the step of modifying the pre-determined amount of time based on the assessed responsiveness of the patient.

19. The method for monitoring a patient's responsiveness according to claim 17, further comprising the steps of determining a physiological parameter of a patient and modifying the pre-determined amount of time based on the physiological parameter.

20. The method for monitoring a patient's responsiveness according to claim 19, wherein the physiological parameter of the patient is selected from the group consisting of pulse oximetry, blood pressure, heart rate, and respiratory rate.

21. The method for monitoring a patient's responsiveness according to claim 17, wherein the method for monitoring a patient's responsiveness is performed in conjunction with a medical procedure.

22. The method for monitoring a patient's responsiveness according to claim 21, wherein the medical procedure includes the delivery of drugs to the patient.

23. The method for monitoring a patient's responsiveness according to claim 22, wherein the delivery of drugs is altered based on the assessed responsiveness of the patient.

24. The method for monitoring a patient's responsiveness according to claim 22, wherein the drugs are for sedation and analgesia.

25. The method for monitoring a patient's responsiveness according to claim 14, wherein the at least one stimulus is part of a series of stimuli, the series comprising a pre-determined number of stimuli.

26. The method for monitoring a patient's responsiveness according to claim 25, wherein a subsequent stimulus of the series of stimuli is of a heightened intensity to the previous stimulus of the series.

27. The method for monitoring a patient's responsiveness according to claim 25, wherein a subsequent stimulus of the series of stimuli is separated by a pre-determined interval of no stimuli from the previous stimulus of the series.

28. A care system for alleviating patient pain, anxiety and discomfort associated with medical or surgical procedures said system comprising:

- (a) one or more patient health monitor devices adapted so as to receive a signal reflecting at least one physiological condition;
- (b) a patient responsiveness monitor adapted so as to receive at least one signal reflecting patient responsiveness;
- (c) a drug delivery controller supplying one or more drugs;
- (d) a memory device storing a safety data set reflecting safe and undesirable parameters of at least one monitored patient physiological condition and of patient responsiveness; and
- (e) an electronic controller interconnected between the one or more patient health monitor devices, the patient responsiveness monitor; the drug delivery controller and the memory device storing the safety data set; wherein said electronic controller receives said signal reflecting at least one physiological condition and said

signal reflecting patient responsiveness, and in response manages the application of the drugs in accord with the safety data set.

**29.** A method of using the care system of claim 28, the method comprising the steps of:

- (a) assessing a level of responsiveness; and
- (b) managing application of drugs in a manner to promote amnesia and to promote loss of responsiveness.

**30.** A method of using the care system of claim 28, to safely administer a medical procedure comprising the steps of

- (a) managing the application of the drugs so as to increase the drugs delivered at a pre-determined rate of increase;
- (b) continually assessing a level of responsiveness during the step of managing the application of the drugs;
- (c) determining there is a loss of responsiveness; and
- (d) determining an effect site concentration during the step of determining there is a loss of responsiveness; and
- (e) managing the application of the drugs so as to maintain said effect site concentration.

**31.** The method according to claim 30, the method further comprising the step of administering a medical procedure during the step of managing the application of the drugs so as to maintain said effect site concentration.

**32.** A method of using the care system of claim 28, to safely administer a medical procedure comprising the steps of:

- (a) managing the application of the drugs so as to increase the drugs delivered at a pre-determined rate of increase;
- (b) continually assessing a level of responsiveness during the step of managing the application of the drugs;
- (c) determining at least one effect site concentration during the step of managing the application of the drugs so as to increase the drugs delivered; and
- (d) determining a predicted effect site concentration that is predicted to exist at a point at which there will be a loss of responsiveness.

**33.** The method according to claim 32, further comprising the step of managing the application of the drugs so as to maintain an effect site concentration at which there is no loss of responsiveness.

\* \* \* \* \*

|                |   |         |            |
|----------------|---|---------|------------|
| 专利名称(译)        | 用于自动评估和监测患者的响应性的装置和方法   |         |            |
| 公开(公告)号        | <a href="#">US20030145854A1</a>   | 公开(公告)日 | 2003-08-07 |
| 申请号            | US10/329763   | 申请日     | 2002-12-27 |
| [标]申请(专利权)人(译) | 斯科特实验室公司  |         |            |
| 申请(专利权)人(译)    | SCOTT实验室, INC.  |         |            |
| 当前申请(专利权)人(译)  | SCOTT实验室, INC.  |         |            |
| [标]发明人         | HICKLE RANDALL S  |         |            |
| 发明人            | HICKLE, RANDALL S.  |         |            |
| IPC分类号         | A61B5/00 A61B5/11 A61B5/16 A61K9/22 A61M16/00 A61M16/01 G06F19/00   |         |            |
| CPC分类号         | A61B5/1106 A61M16/0084 A61B5/411 A61B5/417 A61B5/4821 A61M5/142 A61M5/1723 A61M16/0051 A61M16/0078 A61M16/009 A61M16/01 A61M2005/1405 A61M2016/0036 A61M2205/3561 A61M2209/084 A61M2230/205 A61M2230/43 A61M2230/432 G06F19/3456 G06F19/3406 A61B5/162 A61M16/0093 A61M16/026 A61M16/1015 A61M16/107 A61M2016/1025 A61M2205/505 G16H20/10 G16H20/40 G16H40/63 |         |            |
| 优先权            | 60/087841 1998-06-03 US<br>60/342773 2001-12-28 US  |         |            |
| 其他公开文献         | US7565905   |         |            |
| 外部链接           | <a href="#">Espacenet</a> <a href="#">USPTO</a>   |         |            |

摘要(译)

提供了一种护理系统和相关方法，用于减轻与医疗或外科手术相关的患者疼痛，焦虑和不适。护理系统通过提供响应性监测系统来促进程序性临床医生安全有效地向患者提供镇静和镇痛，并且在某种程度上提供健忘症，所述响应性监测系统监测患者的响应性并产生表示患者响应水平的值。在本发明的其他方面，响应性监测系统是包括患者查询和响应设备的自动化系统。该系统和方法的另外的实施方案涉及减轻患者的疼痛或不适，同时实现与患者健康状况的监测相关的安全药物递送（自动化，临床医生控制的或患者控制的）。

