



US008790259B2

(12) **United States Patent**
Katra et al.

(10) **Patent No.:** **US 8,790,259 B2**
(45) **Date of Patent:** **Jul. 29, 2014**

(54) **METHOD AND APPARATUS FOR REMOTE DETECTION AND MONITORING OF FUNCTIONAL CHRONOTROPIC INCOMPETENCE**

(58) **Field of Classification Search**
None
See application file for complete search history.

(75) Inventors: **Rodolphe Katra**, Blaine, MN (US);
Niranjan Chakravarthy, Minneapolis, MN (US); **Imad Libbus**, Saint Paul, MN (US)

(56) **References Cited**

U.S. PATENT DOCUMENTS

834,261 A 10/1906 Chambers
2,087,124 A 7/1937 Smith et al.

(Continued)

(73) Assignee: **Corventis, Inc.**, San Jose, CA (US)

FOREIGN PATENT DOCUMENTS

(*) Notice: Subject to any disclaimer, the term of this patent is extended or adjusted under 35 U.S.C. 154(b) by 438 days.

EP 1579801 A1 9/2005
WO WO 00/79255 A1 12/2000

(Continued)

OTHER PUBLICATIONS

(21) Appl. No.: **12/910,076**

(22) Filed: **Oct. 22, 2010**

Lauer MS, et al., "Impaired Chronotropic Response to Exercise Stress Testing as a Predictor of Mortality," JAMA, 1999; 281(6): 524-529.*

(65) **Prior Publication Data**

US 2011/0270049 A1 Nov. 3, 2011

(Continued)

Related U.S. Application Data

Primary Examiner — Michael Kahelin
Assistant Examiner — Mitchell E Alter

(60) Provisional application No. 61/253,866, filed on Oct. 22, 2009.

(74) *Attorney, Agent, or Firm* — Kilpatrick Townsend & Stockton LLP

(51) **Int. Cl.**

A61B 5/00 (2006.01)
A61B 5/02 (2006.01)
A61B 5/053 (2006.01)
A61B 5/11 (2006.01)
A61B 5/0245 (2006.01)
A61B 5/0205 (2006.01)
A61B 5/08 (2006.01)

(57) **ABSTRACT**

Methods and apparatus to determine the presence of and track functional chronotropic incompetence (hereinafter "CI") in an in-home setting under conditions of daily living. The functional CI of the patient may be determined with one or more of a profile of measured patient heart rates, a measured maximum patient heart rate, or a peak of the heart rate profile. The functional CI of the patient may be determined with the measured heart rate profile, in which the measured heart rate profile may correspond to heart rates substantially less than the maximum heart rate of the patient, such that the heart rate can be safely measured when the patient is remote from a health care provider. The functional CI of the patient may be determined based a peak of the remotely measured heart rate profile, for example a peak corresponding to the mode of the heart rate distribution profile.

(52) **U.S. Cl.**

CPC **A61B 5/0002** (2013.01); **A61B 5/0537** (2013.01); **A61B 5/1118** (2013.01); **A61B 5/0245** (2013.01); **A61B 2560/0412** (2013.01); **A61B 5/0205** (2013.01); **A61B 5/0816** (2013.01)

USPC **600/301**; **600/508**

13 Claims, 18 Drawing Sheets

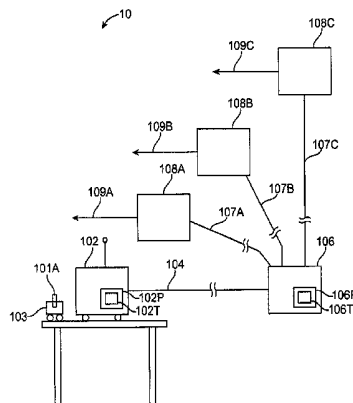
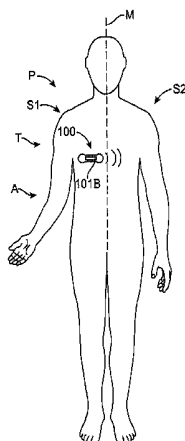

(56)

References Cited

U.S. PATENT DOCUMENTS

2,184,511 A	12/1939	Bagno et al.	5,297,556 A	3/1994	Shankar
3,170,459 A	2/1965	Phipps et al.	5,301,677 A	4/1994	Hsung
3,232,291 A	2/1966	Parker	5,319,363 A	6/1994	Welch et al.
3,370,459 A	2/1968	Cescati	5,331,966 A	7/1994	Bennett et al.
3,517,999 A	6/1970	Weaver	5,335,664 A	8/1994	Nagashima
3,620,216 A	11/1971	Szymanski	5,343,869 A	9/1994	Pross et al.
3,677,260 A	7/1972	Funfstuck et al.	5,353,793 A	10/1994	Bornn
3,805,769 A	4/1974	Sessions	5,362,069 A	11/1994	Hall-Tipping
3,845,757 A	11/1974	Weyer	5,375,604 A	12/1994	Kelly et al.
3,874,368 A	4/1975	Asrican	5,411,530 A	5/1995	Akhtar
3,882,853 A	5/1975	Gofman et al.	5,437,285 A	8/1995	Verrier et al.
3,942,517 A	3/1976	Bowles et al.	5,443,073 A	8/1995	Wang et al.
3,972,329 A	8/1976	Kaufman	5,449,000 A	9/1995	Libke et al.
4,008,712 A	2/1977	Nyboer	5,450,845 A	9/1995	Axelgaard
4,024,312 A	5/1977	Korpman	5,454,377 A	10/1995	Dzwonczyk et al.
4,077,406 A	3/1978	Sandhage et al.	5,464,012 A	11/1995	Falcone
4,121,573 A	10/1978	Crovella et al.	5,469,859 A	11/1995	Tsoglin et al.
4,141,366 A	2/1979	Cross, Jr. et al.	5,482,036 A	1/1996	Diab et al.
RE30,101 E	9/1979	Kubicek et al.	5,496,361 A	3/1996	Moberg et al.
4,185,621 A	1/1980	Morrow	5,503,157 A	4/1996	Sramek
4,216,462 A	8/1980	McGrath et al.	5,511,548 A	4/1996	Raizzi et al.
4,300,575 A	11/1981	Wilson	5,511,553 A	4/1996	Segalowitz
4,308,872 A	1/1982	Watson et al.	5,518,001 A	5/1996	Snell
4,358,678 A	11/1982	Lawrence	5,523,742 A	6/1996	Simkins et al.
4,409,983 A	10/1983	Albert	5,529,072 A	6/1996	Sramek
4,450,527 A	5/1984	Sramek	5,544,661 A	8/1996	Davis et al.
4,451,254 A	5/1984	Dinius et al.	5,558,638 A	9/1996	Evers et al.
4,478,223 A	10/1984	Allor	5,560,368 A	10/1996	Berger
4,498,479 A	2/1985	Martio et al.	5,564,429 A	10/1996	Bornn et al.
4,522,211 A	6/1985	Bare et al.	5,564,434 A	10/1996	Halperin et al.
4,661,103 A	4/1987	Harman	5,566,671 A	10/1996	Lyons
4,664,129 A	5/1987	Helzel et al.	5,575,284 A	11/1996	Athan et al.
4,669,480 A	6/1987	Hoffman	5,607,454 A	3/1997	Cameron et al.
4,673,387 A	6/1987	Phillips et al.	5,632,272 A	5/1997	Diab et al.
4,681,118 A	7/1987	Asai et al.	5,634,468 A	6/1997	Platt et al.
4,692,685 A	9/1987	Blaze	5,642,734 A	7/1997	Ruben et al.
4,699,146 A	10/1987	Sieverding	5,673,704 A	10/1997	Marchlinski et al.
4,721,110 A	1/1988	Lampadius	5,678,562 A	10/1997	Sellers
4,730,611 A	3/1988	Lamb	5,687,717 A	11/1997	Halpern et al.
4,781,200 A	11/1988	Baker	5,718,234 A	2/1998	Warden et al.
4,793,362 A	12/1988	Tedner	5,724,025 A	3/1998	Tavori
4,838,273 A	6/1989	Cartmell	5,738,107 A	4/1998	Martinsen et al.
4,838,279 A	6/1989	Fore	5,748,103 A	5/1998	Flach et al.
4,850,370 A	7/1989	Dower	5,767,791 A	6/1998	Stoop et al.
4,880,004 A	11/1989	Baker, Jr. et al.	5,769,793 A	6/1998	Pincus et al.
4,895,163 A	1/1990	Libke et al.	5,772,508 A	6/1998	Sugita et al.
4,911,175 A	3/1990	Shizgal	5,772,586 A	6/1998	Heinonen et al.
4,945,916 A	8/1990	Kretschmer et al.	5,778,882 A	7/1998	Raymond et al.
4,955,381 A	9/1990	Way et al.	5,788,643 A	8/1998	Feldman
4,966,158 A	10/1990	Honma et al.	5,803,915 A	9/1998	Kremenchugsky et al.
4,981,139 A	1/1991	Pfohl	5,807,272 A	9/1998	Kun
4,988,335 A	1/1991	Prindle et al.	5,814,079 A	9/1998	Kieval et al.
4,989,612 A	2/1991	Fore	5,817,035 A	10/1998	Sullivan
5,001,632 A	3/1991	Hall-Tipping	5,833,603 A	11/1998	Kovacs et al.
5,012,810 A	5/1991	Strand et al.	5,836,990 A	11/1998	Li
5,025,791 A	6/1991	Niwa	5,855,614 A	1/1999	Stevens et al.
5,027,824 A	7/1991	Dougherty et al.	5,860,860 A	1/1999	Clayman
5,050,612 A	9/1991	Matsumura	5,862,802 A	1/1999	Bird
5,063,937 A	11/1991	Ezenwa et al.	5,862,803 A	1/1999	Besson et al.
5,080,099 A	1/1992	Way et al.	5,865,733 A	2/1999	Malinouskas et al.
5,083,563 A	1/1992	Collins	5,876,353 A	3/1999	Riff
5,086,781 A	2/1992	Bookspan	5,904,708 A	5/1999	Goedeke
5,113,869 A	5/1992	Nappholz et al.	5,935,079 A	8/1999	Swanson et al.
5,125,412 A	6/1992	Thornton	5,941,831 A	8/1999	Turcott
5,133,355 A	7/1992	Strand et al.	5,944,659 A	8/1999	Flach et al.
5,140,985 A	8/1992	Schroeder et al.	5,949,636 A	9/1999	Johnson et al.
5,150,708 A	9/1992	Brooks	5,957,854 A	9/1999	Besson et al.
5,168,874 A	12/1992	Segalowitz	5,957,861 A	9/1999	Combs et al.
5,226,417 A	7/1993	Swedlow et al.	5,964,703 A	10/1999	Goodman et al.
5,241,300 A	8/1993	Buschmann	5,970,986 A	10/1999	Bolz et al.
5,257,627 A	11/1993	Rapoport	5,984,102 A	11/1999	Tay
5,271,411 A	12/1993	Ripley et al.	5,987,352 A	11/1999	Klein et al.
5,273,532 A	12/1993	Niezink et al.	6,007,532 A	12/1999	Netherly
5,282,840 A	2/1994	Hudrlik	6,027,523 A	2/2000	Schmieding
5,291,013 A	3/1994	Nafarrate et al.	6,045,513 A	4/2000	Stone et al.
			6,047,203 A	4/2000	Sackner et al.
			6,047,259 A	4/2000	Campbell et al.
			6,049,730 A	4/2000	Kristbjarnarson
			6,050,267 A	4/2000	Nardella et al.

(56)

References Cited

U.S. PATENT DOCUMENTS

6,050,951 A	4/2000	Friedman et al.	6,577,897 B1	6/2003	Shurubura et al.
6,052,615 A	4/2000	Feild et al.	6,579,231 B1	6/2003	Phipps
6,080,106 A	6/2000	Lloyd et al.	6,580,942 B1	6/2003	Willshire
6,081,735 A	6/2000	Diab et al.	6,584,343 B1	6/2003	Ransbury et al.
6,095,991 A	8/2000	Krausman et al.	6,587,715 B2	7/2003	Singer
6,102,856 A	8/2000	Groff et al.	6,589,170 B1	7/2003	Flach et al.
6,104,949 A	8/2000	Pitts Crick et al.	6,595,927 B2	7/2003	Pitts-Crick et al.
6,112,224 A	8/2000	Peifer et al.	6,595,929 B2	7/2003	Stivoric et al.
6,117,077 A	9/2000	Del Mar et al.	6,600,949 B1	7/2003	Turcott
6,125,297 A	9/2000	Siconolfi	6,602,201 B1	8/2003	Hepp et al.
6,129,744 A	10/2000	Boute	6,605,038 B1	8/2003	Teller et al.
6,141,575 A	10/2000	Price	6,611,705 B2	8/2003	Hopman et al.
6,144,878 A	11/2000	Schroepel et al.	6,611,783 B2	8/2003	Kelly et al.
6,164,284 A	12/2000	Schulman et al.	6,616,606 B1	9/2003	Petersen et al.
6,181,963 B1	1/2001	Chin et al.	6,622,042 B1	9/2003	Thacker
6,185,452 B1	2/2001	Schulman et al.	6,636,754 B1	10/2003	Baura et al.
6,190,313 B1	2/2001	Hinkle	6,641,542 B2	11/2003	Cho et al.
6,190,324 B1	2/2001	Kieval et al.	6,645,153 B2	11/2003	Kroll et al.
6,198,394 B1	3/2001	Jacobsen et al.	6,649,829 B2	11/2003	Garber et al.
6,198,955 B1	3/2001	Axelgaard et al.	6,650,917 B2	11/2003	Diab et al.
6,208,894 B1	3/2001	Schulman et al.	6,658,300 B2	12/2003	Govari et al.
6,212,427 B1	4/2001	Hoover	6,659,947 B1	12/2003	Carter et al.
6,213,942 B1	4/2001	Flach et al.	6,659,949 B1	12/2003	Lang et al.
6,225,901 B1	5/2001	Kail, IV	6,687,540 B2	2/2004	Marcovecchio
6,245,021 B1	6/2001	Stampfer	6,697,658 B2	2/2004	Al-Ali
6,259,939 B1	7/2001	Rogel	RE38,476 E	3/2004	Diab et al.
6,272,377 B1	8/2001	Sweeney et al.	6,699,200 B2	3/2004	Cao et al.
6,277,078 B1	8/2001	Porat et al.	6,701,271 B2	3/2004	Willner et al.
6,287,252 B1	9/2001	Lugo	6,714,813 B2	3/2004	Ishigooka et al.
6,289,238 B1	9/2001	Besson et al.	RE38,492 E	4/2004	Diab et al.
6,290,646 B1	9/2001	Cosentino et al.	6,721,594 B2	4/2004	Conley et al.
6,295,466 B1	9/2001	Ishikawa et al.	6,728,572 B2	4/2004	Hsu et al.
6,305,943 B1	10/2001	Pougatchev et al.	6,748,269 B2	6/2004	Thompson et al.
6,306,088 B1	10/2001	Krausman et al.	6,749,566 B2	6/2004	Russ
6,308,094 B1	10/2001	Shusterman et al.	6,751,498 B1	6/2004	Greenberg et al.
6,312,378 B1	11/2001	Bardy	6,760,617 B2	7/2004	Ward et al.
6,315,721 B2	11/2001	Schulman et al.	6,773,396 B2	8/2004	Flach et al.
6,327,487 B1	12/2001	Stratbucker	6,775,566 B2	8/2004	Nissila
6,336,903 B1	1/2002	Bardy	6,790,178 B1	9/2004	Mault et al.
6,339,722 B1	1/2002	Heethaar et al.	6,795,722 B2	9/2004	Sheraton et al.
6,343,140 B1	1/2002	Brooks	6,814,706 B2	11/2004	Barton et al.
6,347,245 B1	2/2002	Lee et al.	6,816,744 B2	11/2004	Garfield et al.
6,358,208 B1	3/2002	Lang et al.	6,821,249 B2	11/2004	Casscells, III et al.
6,385,473 B1	5/2002	Haines et al.	6,824,515 B2	11/2004	Suorsa et al.
6,398,727 B1	6/2002	Bui et al.	6,827,690 B2	12/2004	Bardy
6,400,982 B2	6/2002	Sweeney et al.	6,829,503 B2	12/2004	Alt
6,411,853 B1	6/2002	Millot et al.	6,858,006 B2	2/2005	MacCarter et al.
6,416,471 B1	7/2002	Kumar et al.	6,871,211 B2	3/2005	Labounty et al.
6,442,422 B1	8/2002	Duckert	6,878,121 B2	4/2005	Krausman et al.
6,450,820 B1	9/2002	Palsson et al.	6,879,850 B2	4/2005	Kimball
6,450,953 B1	9/2002	Place et al.	6,881,191 B2	4/2005	Oakley et al.
6,453,186 B1	9/2002	Lovejoy et al.	6,887,201 B2	5/2005	Bardy
6,454,707 B1	9/2002	Casscells, III et al.	6,890,096 B2	5/2005	Tokita et al.
6,454,708 B1	9/2002	Ferguson et al.	6,893,396 B2	5/2005	Schulze et al.
6,459,930 B1	10/2002	Takehara et al.	6,894,204 B2	5/2005	Dunshee
6,463,328 B1	10/2002	John	6,906,530 B2	6/2005	Geisel
6,473,640 B1	10/2002	Erlebacher	6,912,414 B2	6/2005	Tong
6,480,733 B1	11/2002	Turcott	6,936,006 B2	8/2005	Sabra
6,480,734 B1	11/2002	Zhang et al.	6,940,403 B2	9/2005	Kail, IV
6,490,478 B1	12/2002	Zhang et al.	6,942,622 B1	9/2005	Turcott
6,491,647 B1	12/2002	Bridger et al.	6,952,695 B1	10/2005	Trinks et al.
6,494,829 B1	12/2002	New, Jr. et al.	6,970,742 B2	11/2005	Mann et al.
6,512,949 B1	1/2003	Combs et al.	6,972,683 B2	12/2005	Lestienne et al.
6,520,967 B1	2/2003	Cauthen	6,978,177 B1	12/2005	Chen et al.
6,527,711 B1	3/2003	Stivoric et al.	6,980,851 B2	12/2005	Zhu et al.
6,527,729 B1	3/2003	Turcott	6,980,852 B2	12/2005	Jersey-Willuhn et al.
6,544,173 B2	4/2003	West et al.	6,985,078 B2	1/2006	Suzuki et al.
6,544,174 B2	4/2003	West et al.	6,987,965 B2	1/2006	Ng et al.
6,551,251 B2	4/2003	Zuckerwar et al.	6,988,989 B2	1/2006	Weiner et al.
6,551,252 B2	4/2003	Sackner et al.	6,993,378 B2	1/2006	Wiederhold et al.
6,569,160 B1	5/2003	Goldin et al.	6,997,879 B1	2/2006	Turcott
6,572,557 B2	6/2003	Tchou et al.	7,003,346 B2	2/2006	Singer
6,572,636 B1	6/2003	Hagen et al.	7,018,338 B2	3/2006	Vetter et al.
6,577,139 B2	6/2003	Cooper	7,020,508 B2	3/2006	Stivoric et al.
6,577,893 B1	6/2003	Besson et al.	7,027,862 B2	4/2006	Dahl et al.
			7,041,062 B2	5/2006	Friedrichs et al.
			7,044,911 B2	5/2006	Drinan et al.
			7,047,067 B2	5/2006	Gray et al.
			7,050,846 B2	5/2006	Sweeney et al.

(56)

References Cited

U.S. PATENT DOCUMENTS

7,054,679	B2	5/2006	Hirsh	2003/0083581	A1	5/2003	Taha et al.
7,059,767	B2	6/2006	Tokita et al.	2003/0085717	A1	5/2003	Cooper
7,088,242	B2	8/2006	Aupperle et al.	2003/0087244	A1	5/2003	McCarthy
7,113,826	B2	9/2006	Henry et al.	2003/0092975	A1	5/2003	Casscells, III et al.
7,118,531	B2	10/2006	Krill	2003/0093125	A1	5/2003	Zhu et al.
7,127,370	B2	10/2006	Kelly, Jr. et al.	2003/0093298	A1	5/2003	Hernandez et al.
7,129,836	B2	10/2006	Lawson et al.	2003/0100367	A1	5/2003	Cooke
7,130,396	B2	10/2006	Rogers et al.	2003/0135127	A1	7/2003	Sackner et al.
7,130,679	B2	10/2006	Parsonnet et al.	2003/0143544	A1	7/2003	McCarthy
7,133,716	B2	11/2006	Kraemer et al.	2003/0149349	A1	8/2003	Jensen
7,136,697	B2	11/2006	Singer	2003/0187370	A1	10/2003	Kodama
7,136,703	B1	11/2006	Cappa et al.	2003/0191503	A1	10/2003	Zhu et al.
7,142,907	B2	11/2006	Xue et al.	2003/0212319	A1	11/2003	Magill
7,149,574	B2	12/2006	Yun et al.	2003/0221687	A1	12/2003	Kaigler
7,149,773	B2	12/2006	Haller et al.	2003/0233129	A1	12/2003	Matos
7,153,262	B2	12/2006	Stivoric et al.	2004/0006279	A1	1/2004	Arad
7,156,807	B2	1/2007	Carter et al.	2004/0010303	A1	1/2004	Bolea et al.
7,156,808	B2	1/2007	Quy	2004/0015058	A1	1/2004	Besson et al.
7,160,252	B2	1/2007	Cho et al.	2004/0019292	A1	1/2004	Drinan et al.
7,160,253	B2	1/2007	Nissila	2004/0044293	A1	3/2004	Burton
7,166,063	B2	1/2007	Rahman et al.	2004/0049132	A1	3/2004	Barron et al.
7,167,743	B2	1/2007	Heruth et al.	2004/0073094	A1	4/2004	Baker
7,184,821	B2	2/2007	Belalcazar et al.	2004/0073126	A1	4/2004	Rowlandson
7,191,000	B2	3/2007	Zhu et al.	2004/0077954	A1	4/2004	Oakley et al.
7,194,306	B1	3/2007	Turcott	2004/0100376	A1	5/2004	Lye et al.
7,206,630	B1	4/2007	Tarler	2004/0102683	A1	5/2004	Khanuja et al.
7,212,849	B2	5/2007	Zhang et al.	2004/0106951	A1	6/2004	Edman et al.
7,215,984	B2	5/2007	Diab et al.	2004/0127790	A1	7/2004	Lang et al.
7,215,991	B2	5/2007	Besson et al.	2004/0133079	A1	7/2004	Mazar et al.
7,238,159	B2	7/2007	Banet et al.	2004/0133081	A1	7/2004	Teller et al.
7,248,916	B2	7/2007	Bardy	2004/0134496	A1	7/2004	Cho et al.
7,251,524	B1	7/2007	Hepp et al.	2004/0143170	A1	7/2004	DuRousseau
7,257,438	B2	8/2007	Kinast	2004/0147969	A1	7/2004	Mann et al.
7,261,690	B2	8/2007	Teller et al.	2004/0152956	A1	8/2004	Korman
7,277,741	B2	10/2007	Debreczeny et al.	2004/0158132	A1	8/2004	Zaleski
7,284,904	B2	10/2007	Tokita et al.	2004/0167389	A1	8/2004	Brabrand
7,285,090	B2	10/2007	Stivoric et al.	2004/0172080	A1	9/2004	Stadler et al.
7,294,105	B1	11/2007	Islam	2004/0199056	A1	10/2004	Husemann et al.
7,295,879	B2	11/2007	Denker et al.	2004/0215240	A1	10/2004	Lovett et al.
7,297,119	B2	11/2007	Westbrook et al.	2004/0215247	A1	10/2004	Bolz
7,318,808	B2	1/2008	Tarassenko et al.	2004/0220639	A1	11/2004	Mulligan et al.
7,319,386	B2	1/2008	Collins, Jr. et al.	2004/0225199	A1	11/2004	Evanyk et al.
7,336,187	B2	2/2008	Hubbard, Jr. et al.	2004/0225203	A1	11/2004	Jemison et al.
7,346,380	B2	3/2008	Axelgaard et al.	2004/0243018	A1	12/2004	Organ et al.
7,382,247	B2	6/2008	Welch et al.	2004/0267142	A1	12/2004	Paul
7,384,398	B2	6/2008	Gagnadre et al.	2005/0004506	A1	1/2005	Gyory
7,390,299	B2	6/2008	Weiner et al.	2005/0015094	A1	1/2005	Keller
7,395,106	B2	7/2008	Ryu et al.	2005/0015095	A1	1/2005	Keller
7,423,526	B2	9/2008	Despotis	2005/0020935	A1	1/2005	Helzel et al.
7,423,537	B2	9/2008	Bonnet et al.	2005/0027175	A1	2/2005	Yang
7,443,302	B2	10/2008	Reeder et al.	2005/0027204	A1	2/2005	Kligfield et al.
7,450,024	B2	11/2008	Wildman et al.	2005/0027207	A1	2/2005	Westbrook et al.
7,468,032	B2	12/2008	Stahmann et al.	2005/0027918	A1	2/2005	Govindarajulu et al.
8,116,841	B2*	2/2012	Bly et al. 600/391	2005/0043675	A1	2/2005	Pastore et al.
8,249,686	B2	8/2012	Libbus et al.	2005/0054944	A1	3/2005	Nakada et al.
8,285,356	B2	10/2012	Bly et al.	2005/0059867	A1	3/2005	Chung
2001/0047127	A1	11/2001	New, Jr. et al.	2005/0065445	A1	3/2005	Arzbaecher et al.
2002/0019586	A1	2/2002	Teller et al.	2005/0065571	A1	3/2005	Imran
2002/0019588	A1	2/2002	Marro et al.	2005/0070768	A1	3/2005	Zhu et al.
2002/0028989	A1	3/2002	Pelletier et al.	2005/0070778	A1	3/2005	Lackey et al.
2002/0032581	A1	3/2002	Reitberg	2005/0080346	A1	4/2005	Gianchandani et al.
2002/0045836	A1	4/2002	Alkawwas	2005/0080460	A1	4/2005	Wang et al.
2002/0088465	A1	7/2002	Hill	2005/0080463	A1	4/2005	Stahmann et al.
2002/0099277	A1	7/2002	Harry et al.	2005/0085734	A1	4/2005	Tehrani
2002/0116009	A1	8/2002	Fraser et al.	2005/0091338	A1	4/2005	de la Huerga
2002/0123672	A1	9/2002	Christophersom et al.	2005/0096513	A1	5/2005	Ozguz et al.
2002/0123674	A1	9/2002	Picchi et al.	2005/0113703	A1	5/2005	Farrington et al.
2002/0138017	A1	9/2002	Bui et al.	2005/0124878	A1	6/2005	Sharony
2002/0167389	A1	11/2002	Uchikoba et al.	2005/0124901	A1	6/2005	Misczynski et al.
2003/0009092	A1	1/2003	Parker	2005/0124908	A1	6/2005	Belalcazar et al.
2003/0023184	A1	1/2003	Pitts-Crick et al.	2005/0131288	A1	6/2005	Turner et al.
2003/0028221	A1	2/2003	Zhu et al.	2005/0137464	A1	6/2005	Bomba
2003/0028327	A1	2/2003	Brunner et al.	2005/0137626	A1	6/2005	Pastore et al.
2003/0051144	A1	3/2003	Williams	2005/0148895	A1	7/2005	Misczynski et al.
2003/0055460	A1	3/2003	Owen et al.	2005/0158539	A1	7/2005	Murphy et al.
				2005/0177038	A1	8/2005	Kolpin et al.
				2005/0187482	A1	8/2005	O'Brien et al.
				2005/0187796	A1	8/2005	Rosenfeld et al.
				2005/0192488	A1	9/2005	Bryenton et al.

(56)

References Cited

U.S. PATENT DOCUMENTS

2005/0197654	A1	9/2005	Edman et al.	2006/0224079	A1	10/2006	Washchuk
2005/0203433	A1	9/2005	Singer	2006/0235281	A1	10/2006	Tuccillo
2005/0203435	A1	9/2005	Nakada	2006/0235316	A1	10/2006	Ungless et al.
2005/0203637	A1	9/2005	Edman et al.	2006/0235489	A1	10/2006	Drew et al.
2005/0206518	A1	9/2005	Welch et al.	2006/0238333	A1	10/2006	Welch et al.
2005/0215914	A1	9/2005	Bornzin et al.	2006/0241641	A1	10/2006	Albans et al.
2005/0215918	A1	9/2005	Frantz et al.	2006/0241701	A1	10/2006	Markowitz et al.
2005/0228234	A1	10/2005	Yang	2006/0241722	A1	10/2006	Thacker et al.
2005/0228238	A1	10/2005	Monitzer	2006/0247545	A1	11/2006	St. Martin
2005/0228244	A1	10/2005	Banet	2006/0252999	A1	11/2006	Devaul et al.
2005/0239493	A1	10/2005	Batkin et al.	2006/0253005	A1	11/2006	Drinan et al.
2005/0240087	A1	10/2005	Keenan et al.	2006/0253044	A1	11/2006	Zhang et al.
2005/0251044	A1	11/2005	Hocotr et al.	2006/0258952	A1	11/2006	Stahmann et al.
2005/0256418	A1	11/2005	Mietus et al.	2006/0264730	A1	11/2006	Stivoric et al.
2005/0261598	A1	11/2005	Banet et al.	2006/0264767	A1	11/2006	Shennib
2005/0261743	A1	11/2005	Kroll	2006/0264776	A1	11/2006	Stahmann et al.
2005/0267376	A1	12/2005	Marossero et al.	2006/0271116	A1	11/2006	Stahmann et al.
2005/0267377	A1	12/2005	Marossero et al.	2006/0276714	A1	12/2006	Holt et al.
2005/0267381	A1	12/2005	Benditt et al.	2006/0281981	A1	12/2006	Jang et al.
2005/0267541	A1*	12/2005	Scheiner et al. 607/17	2006/0281996	A1	12/2006	Kuo et al.
2005/0273023	A1	12/2005	Bystrom et al.	2006/0293571	A1	12/2006	Bao et al.
2005/0277841	A1	12/2005	Shennib	2006/0293609	A1	12/2006	Stahmann et al.
2005/0277842	A1	12/2005	Silva	2007/0010721	A1	1/2007	Chen et al.
2005/0277992	A1	12/2005	Koh et al.	2007/0010750	A1	1/2007	Ueno et al.
2005/0280531	A1	12/2005	Fadem et al.	2007/0015973	A1	1/2007	Nanikashvili
2005/0283197	A1	12/2005	Daum et al.	2007/0015976	A1	1/2007	Miesel et al.
2005/0288601	A1	12/2005	Wood et al.	2007/0016089	A1	1/2007	Fischell et al.
2006/0004300	A1	1/2006	Kennedy	2007/0021678	A1	1/2007	Beck et al.
2006/0004377	A1	1/2006	Keller	2007/0021790	A1	1/2007	Kieval et al.
2006/0009697	A1	1/2006	Banet et al.	2007/0021792	A1	1/2007	Kieval et al.
2006/0009701	A1	1/2006	Nissila et al.	2007/0021794	A1	1/2007	Kieval et al.
2006/0010090	A1	1/2006	Brockway et al.	2007/0021796	A1	1/2007	Kieval et al.
2006/0020218	A1	1/2006	Freeman et al.	2007/0021797	A1	1/2007	Kieval et al.
2006/0025661	A1	2/2006	Sweeney et al.	2007/0021798	A1	1/2007	Kieval et al.
2006/0030781	A1	2/2006	Shennib	2007/0021799	A1	1/2007	Kieval et al.
2006/0030782	A1	2/2006	Shennib	2007/0027388	A1	2/2007	Chou
2006/0030892	A1*	2/2006	Kadhiresan et al. 607/19	2007/0027497	A1	2/2007	Parnis
2006/0031102	A1	2/2006	Teller et al.	2007/0032749	A1	2/2007	Overall et al.
2006/0041280	A1	2/2006	Stahmann et al.	2007/0038038	A1	2/2007	Stivoric et al.
2006/0047215	A1	3/2006	Newman et al.	2007/0038078	A1	2/2007	Osadchy
2006/0052678	A1	3/2006	Drinan et al.	2007/0038255	A1	2/2007	Kieval et al.
2006/0058543	A1	3/2006	Walter et al.	2007/0038262	A1	2/2007	Kieval et al.
2006/0058593	A1	3/2006	Drinan et al.	2007/0043301	A1	2/2007	Martinsen et al.
2006/0064030	A1	3/2006	Cosentino et al.	2007/0048224	A1	3/2007	Howell et al.
2006/0064040	A1	3/2006	Berger et al.	2007/0060800	A1	3/2007	Drinan et al.
2006/0064142	A1	3/2006	Chavan et al.	2007/0060802	A1	3/2007	Ghevondian et al.
2006/0066449	A1	3/2006	Johnson	2007/0069887	A1	3/2007	Welch et al.
2006/0074283	A1	4/2006	Henderson et al.	2007/0073132	A1	3/2007	Vosch
2006/0074462	A1	4/2006	Verhoef	2007/0073168	A1	3/2007	Zhang et al.
2006/0075257	A1	4/2006	Martis et al.	2007/0073181	A1	3/2007	Pu et al.
2006/0084881	A1	4/2006	Korzinov et al.	2007/0073361	A1	3/2007	Goren et al.
2006/0085049	A1	4/2006	Cory et al.	2007/0082189	A1	4/2007	Gillette
2006/0089679	A1	4/2006	Zhu et al.	2007/0083092	A1	4/2007	Rippo et al.
2006/0102476	A1	5/2006	Niwa et al.	2007/0092862	A1	4/2007	Gerber
2006/0116592	A1	6/2006	Zhou et al.	2007/0104840	A1	5/2007	Singer
2006/0122474	A1	6/2006	Teller et al.	2007/0106132	A1	5/2007	Elhag et al.
2006/0135858	A1	6/2006	Nidd et al.	2007/0106137	A1	5/2007	Baker, Jr. et al.
2006/0142654	A1	6/2006	Rytky	2007/0106167	A1	5/2007	Kinast
2006/0142820	A1	6/2006	Von Arx et al.	2007/0118039	A1	5/2007	Bodecker et al.
2006/0149168	A1	7/2006	Czarnek	2007/0123756	A1	5/2007	Kitajima et al.
2006/0155183	A1	7/2006	Kroecker et al.	2007/0123903	A1	5/2007	Raymond et al.
2006/0155200	A1	7/2006	Ng	2007/0123904	A1	5/2007	Stad et al.
2006/0161073	A1	7/2006	Singer	2007/0129622	A1	6/2007	Bourget et al.
2006/0161205	A1	7/2006	Mitrani et al.	2007/0129643	A1	6/2007	Kwok et al.
2006/0161459	A9	7/2006	Rosenfeld et al.	2007/0129769	A1	6/2007	Bourget et al.
2006/0173257	A1	8/2006	Nagai et al.	2007/0142715	A1	6/2007	Banet et al.
2006/0173269	A1	8/2006	Glossop	2007/0142732	A1	6/2007	Brockway et al.
2006/0195020	A1	8/2006	Martin et al.	2007/0149282	A1	6/2007	Lu et al.
2006/0195039	A1	8/2006	Drew et al.	2007/0150008	A1	6/2007	Jones et al.
2006/0195097	A1	8/2006	Evans et al.	2007/0150009	A1	6/2007	Kveen et al.
2006/0195144	A1	8/2006	Giftakis et al.	2007/0150029	A1	6/2007	Bourget et al.
2006/0202816	A1	9/2006	Crump et al.	2007/0162089	A1	7/2007	Mosesov
2006/0212097	A1	9/2006	Varadan et al.	2007/0167753	A1	7/2007	Van Wyk et al.
2006/0224051	A1	10/2006	Teller et al.	2007/0167848	A1	7/2007	Kuo et al.
2006/0224072	A1	10/2006	Shennib	2007/0167849	A1	7/2007	Zhang et al.
				2007/0167850	A1	7/2007	Russell et al.
				2007/0172424	A1	7/2007	Roser
				2007/0173705	A1	7/2007	Teller et al.
				2007/0180047	A1	8/2007	Dong et al.

(56)

References Cited

U.S. PATENT DOCUMENTS

2007/0180140 A1 8/2007 Welch et al.
 2007/0191723 A1 8/2007 Prystowsky et al.
 2007/0207858 A1 9/2007 Breving
 2007/0208233 A1 9/2007 Kovacs
 2007/0208235 A1 9/2007 Besson et al.
 2007/0208262 A1 9/2007 Kovacs
 2007/0208263 A1* 9/2007 John et al. 600/509
 2007/0232867 A1 10/2007 Hansmann
 2007/0249946 A1 10/2007 Kumar et al.
 2007/0250121 A1 10/2007 Miesel et al.
 2007/0255120 A1 11/2007 Rosnov
 2007/0255153 A1 11/2007 Kumar et al.
 2007/0255184 A1 11/2007 Shennib
 2007/0255531 A1 11/2007 Drew
 2007/0260133 A1 11/2007 Meyer
 2007/0260155 A1 11/2007 Rapoport et al.
 2007/0260289 A1 11/2007 Giffakis et al.
 2007/0273504 A1 11/2007 Tran
 2007/0276273 A1 11/2007 Watson, Jr.
 2007/0282173 A1 12/2007 Wang et al.
 2007/0299325 A1 12/2007 Farrell et al.
 2008/0004499 A1 1/2008 Davis
 2008/0004904 A1 1/2008 Tran
 2008/0021336 A1 1/2008 Dobak
 2008/0024293 A1 1/2008 Stylos
 2008/0024294 A1 1/2008 Mazar
 2008/0033260 A1 2/2008 Sheppard et al.
 2008/0039700 A1 2/2008 Drinan et al.
 2008/0058614 A1 3/2008 Banet et al.
 2008/0058656 A1 3/2008 Costello et al.
 2008/0059239 A1 3/2008 Gerst et al.
 2008/0091089 A1 4/2008 Guillory et al.
 2008/0114220 A1 5/2008 Banet et al.
 2008/0120784 A1 5/2008 Warner et al.
 2008/0139934 A1 6/2008 McMorrow et al.
 2008/0146892 A1 6/2008 LeBoeuf et al.
 2008/0167538 A1 7/2008 Teller et al.
 2008/0171918 A1 7/2008 Teller et al.
 2008/0171922 A1 7/2008 Teller et al.
 2008/0171929 A1 7/2008 Katims
 2008/0183052 A1 7/2008 Teller et al.
 2008/0200774 A1 8/2008 Luo
 2008/0214903 A1 9/2008 Orbach
 2008/0220865 A1 9/2008 Hsu
 2008/0221399 A1 9/2008 Zhou et al.
 2008/0221402 A1 9/2008 Despotis
 2008/0224852 A1 9/2008 Dicks et al.
 2008/0228084 A1 9/2008 Bedard et al.
 2008/0287751 A1 11/2008 Stivoric et al.
 2008/0287752 A1 11/2008 Stroetz et al.
 2008/0293491 A1 11/2008 Wu et al.
 2008/0294019 A1 11/2008 Tran
 2008/0294020 A1 11/2008 Sapounas
 2008/0318681 A1 12/2008 Rofougaran et al.
 2008/0319279 A1 12/2008 Ramsay et al.
 2008/0319282 A1 12/2008 Tran
 2008/0319290 A1 12/2008 Mao et al.
 2009/0005016 A1 1/2009 Eng et al.
 2009/0018410 A1 1/2009 Coene et al.
 2009/0018456 A1 1/2009 Hung
 2009/0048526 A1 2/2009 Aarts
 2009/0054737 A1 2/2009 Magar et al.
 2009/0062670 A1 3/2009 Sterling et al.
 2009/0073991 A1 3/2009 Landrum et al.
 2009/0076336 A1 3/2009 Mazar et al.
 2009/0076340 A1 3/2009 Libbus et al.
 2009/0076341 A1 3/2009 James et al.
 2009/0076342 A1 3/2009 Amurthur et al.
 2009/0076343 A1 3/2009 James et al.
 2009/0076344 A1 3/2009 Libbus et al.
 2009/0076345 A1 3/2009 Manicka et al.
 2009/0076346 A1 3/2009 James et al.
 2009/0076348 A1 3/2009 Manicka et al.
 2009/0076349 A1 3/2009 Libbus et al.
 2009/0076350 A1 3/2009 Bly et al.

2009/0076363 A1 3/2009 Bly et al.
 2009/0076364 A1 3/2009 Libbus et al.
 2009/0076397 A1 3/2009 Libbus et al.
 2009/0076401 A1 3/2009 Mazar et al.
 2009/0076405 A1 3/2009 Amurthur et al.
 2009/0076410 A1 3/2009 Libbus et al.
 2009/0076559 A1 3/2009 Libbus et al.
 2009/0182204 A1 7/2009 Semler et al.
 2009/0234410 A1 9/2009 Libbus et al.
 2009/0264792 A1 10/2009 Mazar
 2009/0292194 A1 11/2009 Libbus et al.
 2010/0056881 A1 3/2010 Libbus et al.
 2010/0191310 A1 7/2010 Bly et al.
 2011/0144470 A1 6/2011 Mazar et al.
 2011/0245711 A1 10/2011 Katra et al.

FOREIGN PATENT DOCUMENTS

WO WO 01/89362 A2 11/2001
 WO WO 02/092101 A1 11/2002
 WO WO 03/082080 A2 10/2003
 WO WO 2005/051164 A2 6/2005
 WO WO 2005/104930 A1 11/2005
 WO WO 2006/008745 A2 1/2006
 WO WO 2006/102476 A2 9/2006
 WO WO 2006/111878 A1 11/2006
 WO WO 2007/041783 A1 4/2007
 WO WO 2007/106455 A2 9/2007
 WO 2009/116906 A1 9/2009

OTHER PUBLICATIONS

“Acute Decompensated Heart Failure”—Wikipedia Entry, downloaded from: <http://en.wikipedia.org/wiki/Acute_decompensated_heart_failure>, entry page created in 2008, 6 pages total.

“Heart Failure”—Wikipedia Entry, downloaded from the Internet: <http://en.wikipedia.org/wiki/Heart_failure>, entry page created in 2003, 17 pages total.

3M Corporation, “3M Surgical Tapes—Choose the Correct Tape” quicksheet (2004).

Abraham, “New approaches to monitoring heart failure before symptoms appear,” *Rev Cardiovasc Med.* 2006 ;7 Suppl 1 :33-41.

AD5934: 250 kSPS 12-Bit Impedance Converter Network Analyzer, Analog Devices, Rev. A. Retrieved from the Internet: <<http://www.analog.com/static/imported-files/data_sheets/AD5934.pdf>>, 40 pages. Copyright 2005-2008.

Adams, Jr. “Guiding heart failure care by invasive hemodynamic measurements: possible or useful?”, *Journal of Cardiac Failure* 2002; 8(2):71-73.

Adamson et al., “Continuous autonomic assessment in patients with symptomatic heart failure: prognostic value of heart rate variability measured by an implanted cardiac resynchronization device,” *Circulation.* 2004;110:2389-2394.

Adamson et al., “Ongoing right ventricular hemodynamics in heart failure,” *J Am Coll Cardiol.* 2003; 41:565-57.

Adamson, “Integrating device monitoring into the infrastructure and workflow of routine practice,” *Rev Cardiovasc Med.* 2006 ;7 Suppl 1:42-6.

Adhere [presentation], “Insights from the ADHERE Registry: Data from over 100,000 patient cases,” 2005, 70 pages total.

Advanced White Sheet, “Health Information Technology: Improving Patient Safety and Quality of Care,” Jun. 2005, 23 pages.

Aghababian, “Acutely decompensated heart failure: opportunities to improve care and outcomes in the emergency department,” *Rev Cardiovasc Med.* 2002;3 Suppl 4:S3-9.

Albert, “Bioimpedance to prevent heart failure hospitalization,” *Curr Heart Fail Rep. Sep.* 2006;3(3):136-42.

American Heart Association, “Heart Disease and Stroke Statistics—2006 Update,” 2006, 43 pages.

American Heart Association, “Heart Disease and Stroke Statistics—2007 Update. A Report From the American Heart Association Statistics Committee and Stroke Statistics Subcommittee,” *Circulation* 2007; 115:e69-e171.

(56)

References Cited

OTHER PUBLICATIONS

- Belalcazar et al., "Monitoring lung edema using the pacemaker pulse and skin electrodes," *Physiol. Meas.* 2005; 26:S153-S163.
- Bennet, "Development of implantable devices for continuous ambulatory monitoring of central hemodynamic values in heart failure patients," *PACE* Jun. 2005; 28:573-584.
- Bourge, "Case studies in advanced monitoring with the chronicle device," *Rev Cardiovasc Med.* 2006 ;7 Suppl 1:S56-61.
- Braunschweig, "Continuous haemodynamic monitoring during withdrawal of diuretics in patients with congestive heart failure," *European Heart Journal* 2002 23(1):59-69.
- Braunschweig, "Dynamic changes in right ventricular pressures during haemodialysis recorded with an implantable haemodynamic monitor," *Nephrol Dial Transplant* 2006; 21:176-183.
- Brennan, "Measuring a Grounded Impedance Profile Using the AD5933," *Analog Devices*, 2006; retrieved from the internet <<http://http://www.analog.com/static/imported-files/application_notes/427095282381510189AN847_0.pdf>>, 12 pages total.
- Buono et al., "The effect of ambient air temperature on whole-body bioelectrical impedance," *Physiol. Meas.* 2004;25:119-123.
- Burkhoff et al., "Heart failure with a normal ejection fraction: Is it really a disorder of diastolic function?" *Circulation* 2003; 107:656-658.
- Burr et al., "Heart rate variability and 24-hour minimum heart rate," *Biological Research for Nursing*, 2006; 7(4):256-267.
- Cardionet, "CardioNet Mobile Cardiac Outpatient Telemetry: Addendum to Patient Education Guide", CardioNet, Inc., 2007, 2 pages.
- Cardionet, "Patient Education Guide", CardioNet, Inc., 2007, 7 pages.
- Charach et al., "Transthoracic monitoring of the impedance of the right lung in patients with cardiogenic pulmonary edema," *Crit Care Med* Jun. 2001;29(6):1137-1144.
- Charlson et al., "Can disease management target patients most likely to generate high costs? The Impact of Comorbidity," *Journal of General Internal Medicine*, Apr. 2007, 22(4):464-469.
- Chaudhry et al., "Telemonitoring for patients with chronic heart failure: a systematic review," *J Card Fail.* Feb. 2007; 13(1): 56-62.
- Chung et al., "White coat hypertension: Not so benign after all?," *Journal of Human Hypertension* (2003) 17, 807-809.
- Cleland et al., "The EuroHeart Failure survey programme—a survey on the quality of care among patients with heart failure in Europe—Part 1: patient characteristics and diagnosis," *European Heart Journal* 2003 24(5):442-463.
- Cooley, "The Parameters of Transthoracic Electrical Conduction," *Annals of the New York Academy of Sciences*, 1970; 170(2):702-713.
- Cowie et al., "Hospitalization of patients with heart failure. A population-based study," *European Heart Journal* 2002 23(11):877-885.
- Dimri, Chapter 1: Fractals in geophysics and seismology: an introduction, *Fractal Behaviour of the Earth System*, Springer Berlin Heidelberg 2005, pp. 1-22. [Summary and 1st page Only].
- El-Dawlatly et al., "Impedance cardiography: noninvasive assessment of hemodynamics and thoracic fluid content during bariatric surgery," *Obesity Surgery*, May 2005, 15(5):655-658.
- EM Microelectronic—Marin SA, "Plastic Flexible LCD," [product brochure]; retrieved from the Internet: <<<http://www.emmicroelectronic.com/Line.asp?IdLine=48>>>, copyright 2009, 2 pages total.
- Erdmann, "Editorials: The value of diuretics in chronic heart failure demonstrated by an implanted haemodynamic monitor," *European Heart Journal* 2002 23(1):7-9.
- FDA—Medtronic Chronicle Implantable Hemodynamic Monitoring System P050032: Panel Package Section 11: Chronicle IHM Summary of Safety and Effectiveness, 2007; retrieved from the Internet: <http://www.fda.gov/OHRMS/DOCKETS/AC/07/briefing/2007-4284b1_04.pdf>, 77 pages total.
- FDA—Medtronic Inc., Chronicle 9520B Implantable Hemodynamic Monitor Reference Manual, 2007, 112 pages.
- FDA Executive Summary Memorandum, prepared for Mar. 1, 2007 meeting of the Circulatory Systems Devices Advisory Panel, P050032 Medtronic, Inc. Chronicle Implantable Hemodynamic Monitor (IHM) System, 23 pages. Retrieved from the Internet: <<http://www.fda.gov/ohrms/dockets/ac/07/briefing/2007-4284b1_02.pdf>>.
- FDA Executive Summary, Medtronic Chronicle Implantable Hemodynamic Monitoring System P050032: Panel Package Sponsor Executive Summary; vol. 1, section 4: Executive Summary, 2007, 12 pages total. Retrieved from the Internet: <<http://www.fda.gov/OHRMS/DOCKETS/AA/07/briefing/2007-4284b1_03.pdf>>.
- FDA, Draft questions for Chronicle Advisory Panel Meeting, 2007, 3 pages total. Retrieved from the Internet: <<http://www.fda.gov/ohrms/dockets/ac/07/questions/2007-4284q1_draft.pdf>>.
- FDA, References for Mar. 1 Circulatory System Devices Panel, 2007, 1 page total. Retrieved from the Internet: <<http://www.fda.gov/OHRMS/DOCKETS/AC/07/briefing/2007-4284bib1_01.pdf>>.
- Fonarow et al., "Risk stratification for in-hospital mortality in acutely decompensated heart failure: classification and regression tree analysis," *JAMA*. Feb. 2, 2005;293(5):572-580.
- Fonarow, "How well are chronic heart failure patients being managed?," *Rev Cardiovasc Med.* 2006;7 Suppl 1:S3-11.
- Fonarow, "Maximizing Heart Failure Care: Opportunities to Improve Patient Outcomes" [Powerpoint Presentation], A CME National Faculty Program, downloaded from the Internet <<<http://www.medreviews.com/media/MaxHFCore.ppt>>>, 130 pages total.
- Fonarow, "Proactive monitoring and management of the chronic heart failure patient," *Rev Cardiovasc Med.* 2006; 7 Suppl 1:S1-2.
- Fonarow, "The Acute Decompensated Heart Failure National Registry (ADHERE): opportunities to improve care of patients hospitalized with acute decompensated heart failure," *Rev Cardiovasc Med.* 2003;4 Suppl 7:S21-S30.
- Ganion et al., "Intrathoracic impedance to monitor heart failure status: a comparison of two methods in a chronic heart failure dog model," *Congest Heart Fail.* Jul.-Aug. 2005;11(4):177-81, 211.
- Gass et al., "Critical pathways in the management of acute decompensated heart failure: A CME-Accredited monograph," Mount Sinai School of Medicine, 2004, 32 pages total.
- Gheorghiadu et al., "Congestion is an important diagnostic and therapeutic target in heart failure," *Rev Cardiovasc Med.* 2006 ;7 Suppl 1 :12-24.
- Gilliam, III et al., "Changes in heart rate variability, quality of life, and activity in cardiac resynchronization therapy patients: results of the HF-HRV registry," *Pacing and Clinical Electrophysiology*, Jan. 18, 2007; 30(1): 56-64.
- Gilliam, III et al., "Prognostic value of heart rate variability footprint and standard deviation of average 5-minute intrinsic R-R intervals for mortality in cardiac resynchronization therapy patients.," *J Electrocardiol.* Oct. 2007;40(4):336-42.
- Gniadecka, "Localization of dermal edema in lipodermatosclerosis, lymphedema, and cardiac insufficiency high-frequency ultrasound examination of intradermal echogenicity," *J Am Acad Dermatol*, Jul. 1996; 35(1):37-41.
- Goldberg et al., "Randomized trial of a daily electronic home monitoring system in patients with advanced heart failure: The Weight Monitoring in Heart Failure (WHARF) Trial," *American Heart Journal*, Oct. 2003; 416(4):705-712.
- Grap et al., "Actigraphy in the Critically III: Correlation With Activity, Agitation, and Sedation," *American Journal of Critical Care.* 2005;14: 52-60.
- Gudivaka et al., "Single- and multifrequency models for bioelectrical impedance analysis of body water compartments," *J Appl Physiol*, 1999;87(3):1087-1096.
- Guyton et al., Unit V: The Body Fluids and Kidneys, Chapter 25: The Body Fluid Compartments: Extracellular and Intracellular Fluids; Interstitial Fluid and Edema, *Guyton & Hall Textbook of Medical Physiology* 11th Edition, Saunders 2005; pp. 291-306.
- Hadase et al., "Very low frequency power of heart rate variability is a powerful predictor of clinical prognosis in patients with congestive heart Failure," *Circ J* 2004; 68(4):343-347.
- Hallstrom et al., "Structural relationships between measures based on heart beat intervals: potential for improved risk assessment," *IEEE Biomedical Engineering* 2004, 51(8):1414-1420.

(56)

References Cited

OTHER PUBLICATIONS

- HFSA 2006 Comprehensive Heart Failure Practice Guideline—Executive Summary: HFSA 2006 Comprehensive Heart Failure Practice Guideline, *Journal of Cardiac Failure* 2006;12(1):10-e38.
- HFSA 2006 Comprehensive Heart Failure Practice Guideline—Section 12: Evaluation and Management of Patients With Acute Decompensated Heart Failure, *Journal of Cardiac Failure* 2006;12(1):e86-e103.
- HFSA 2006 Comprehensive Heart Failure Practice Guideline—Section 2: Conceptualization and Working Definition of Heart Failure, *Journal of Cardiac Failure* 2006;12(1):e10-e11.
- HFSA 2006 Comprehensive Heart Failure Practice Guideline—Section 3: Prevention of Ventricular Remodeling Cardiac Dysfunction, and Heart Failure Overview, *Journal of Cardiac Failure* 2006;12(1):e12-e15.
- HFSA 2006 Comprehensive Heart Failure Practice Guideline—Section 4: Evaluation of Patients for Ventricular Dysfunction and Heart Failure, *Journal of Cardiac Failure* 2006;12(1):e16-e25.
- HFSA 2006 Comprehensive Heart Failure Practice Guideline—Section 8: Disease Management in Heart Failure Education and Counseling, *Journal of Cardiac Failure* 2006;12(1):e58-e68.
- HRV Enterprises, LLC, “Heart Rate Variability Seminars,” downloaded from the Internet: <<<http://hrventerprise.com/>>> on Apr. 24, 2008, 3 pages total.
- HRV Enterprises, LLC, “LoggerPro HRV Biosignal Analysis,” downloaded from the Internet: <<<http://hrventerprise.com/products.html>>> on Apr. 24, 2008, 3 pages total.
- Hunt et al., “ACC/AHA 2005 Guideline Update for the Diagnosis and Management of Chronic Heart Failure in the Adult: A Report of the American College of Cardiology/American Heart Association Task Force on Practice Guidelines (Writing Committee to Update the 2001 Guidelines for the Evaluation and Management of Heart Failure): Developed in Collaboration With the American College of Chest Physicians and the International Society for Heart and Lung Transplantation: Endorsed by the Heart Rhythm Society,” *Circulation*. 2005;112:e154-e235.
- Hunt et al., ACC/AHA Guidelines for the Evaluation and Management of Chronic Heart Failure in the Adult: Executive Summary A Report of the American College of Cardiology/American Heart Association Task Force on Practice Guidelines (Committee to Revise the 1995 Guidelines for the Evaluation and Management of Heart Failure), *Circulation*. 2001;104:2996-3007.
- Imhoff et al., “Noninvasive whole-body electrical bioimpedance cardiac output and invasive thermodilution cardiac output in high-risk surgical patients,” *Critical Care Medicine* 2000; 28(8):2812-2818.
- Jaeger et al., “Evidence for Increased Intrathoracic Fluid Volume in Man at High Altitude,” *J Appl Physiol* 1979; 47(6): 670-676.
- Jaio et al., “Variance fractal dimension analysis of seismic refraction signals,” WESCANEX 97: Communications, Power and Computing. IEEE Conference Proceedings., May 22-23, 1997, pp. 163-167 [Abstract Only].
- Jerant et al., “Reducing the cost of frequent hospital admissions for congestive heart failure: a randomized trial of a home telecare intervention,” *Medical Care* 2001, 39(11):1234-1245.
- Kasper et al., “A randomized trial of the efficacy of multidisciplinary care in heart failure outpatients at high risk of hospital readmission,” *J Am Coll Cardiol*, 2002; 39:471-480.
- Kaukinen, “Cardiac output measurement after coronary artery bypass grafting using bolus thermodilution, continuous thermodilution, and whole-body impedance cardiography,” *Journal of Cardiothoracic and Vascular Anesthesia* 2003; 17(2):199-203.
- Kawaguchi et al., “Combined ventricular systolic and arterial stiffening in patients with heart failure and preserved ejection fraction: implications for systolic and diastolic reserve limitations,” *Circulation*. 2003;107:714-720.
- Kawasaki et al., “Heart rate turbulence and clinical prognosis in hypertrophic cardiomyopathy and myocardial infarction,” *Circ J*. Jul. 2003;67(7):601-604.
- Kearney et al., “Predicting death due to progressive heart failure in patients with mild-to-moderate chronic heart failure,” *J Am Coll Cardiol*, 2002; 40(10):1801-1808.
- Kitzman et al., “Pathophysiological characterization of isolated diastolic heart failure in comparison to systolic heart failure,” *JAMA* Nov. 2002; 288(17):2144-2150.
- Kööbi et al., “Non-invasive measurement of cardiac output: whole-body impedance cardiography in simultaneous comparison with thermodilution and direct oxygen Fick methods,” *Intensive Care Medicine* 1997; 23(11):1132-1137.
- Koyama et al., “Evaluation of heart-rate turbulence as a new prognostic marker in patients with chronic heart failure,” *Circ J* 2002; 66(10):902-907.
- Krumholz et al., “Predictors of readmission among elderly survivors of admission with heart failure,” *American Heart Journal* 2000; 139(1):72-77.
- Kyle et al., “Bioelectrical Impedance Analysis—part I: review of principles and methods,” *Clin Nutr*. Oct. 2004;23(5):1226-1243.
- Kyle et al., “Bioelectrical Impedance Analysis—part II: utilization in clinical practice,” *Clin Nutr*. Oct. 2004;23(5):1430-1453.
- Lee et al., “Predicting mortality among patients hospitalized for heart failure: derivation and validation of a clinical model,” *JAMA* 2003;290(19):2581-2587.
- Leier “The Physical Examination in Heart Failure—Part I,” *Congest Heart Fail*. Jan.-Feb. 2007;13(1):41-47.
- LifeShirt® Model 200 Directions for Use, “Introduction”, VivoMetrics, Inc. 9 page total.
- Liu et al., “Fractal analysis with applications to seismological pattern recognition of underground nuclear explosions,” *Singal Processing*, Sep. 2000, 80(9):1849-1861. [Abstract Only].
- Lozano-Nieto, “Impedance ratio in bioelectrical impedance measurements for body fluid shift determination,” *Proceedings of the IEEE 24th Annual Northeast Bioengineering Conference*, Apr. 9-10, 1998, pp. 24-25.
- Lucreziotti et al., “Five-minute recording of heart rate variability in severe chronic heart failure : Correlates with right ventricular function and prognostic implications,” *American Heart Journal* 2000; 139(6):1088-1095.
- Lütjhe et al., “Detection of heart failure decompensation using intrathoracic impedance monitoring by a triple-chamber implantable defibrillator,” *Heart Rhythm* Sep. 2005;2(9):997-999.
- Magalski et al., “Continuous ambulatory right heart pressure measurements with an implantable hemodynamic monitor: a multicenter, 12-Month Follow-up Study of Patients With Chronic Heart Failure,” *J Card Fail* 2002, 8(2):63-70.
- Mahlberg et al., “Actigraphy in agitated patients with dementia: Monitoring treatment outcomes,” *Zeitschrift für Gerontologie und Geriatrie*, Jun. 2007; 40(3):178-184. [Abstract Only].
- Matthie et al., “Analytic assessment of the various bioimpedance methods used to estimate body water,” *Appl Physiol* 1998; 84(5):1801-1816.
- Matthie, “Second generation mixture theory equation for estimating intracellular water using bioimpedance spectroscopy,” *J Appl Physiol* 2005; 99:780-781.
- McMurray et al., “Heart Failure: Epidemiology, Aetiology, and Prognosis of Heart Failure,” *Heart* 2000;83:596-602.
- Miller, “Home monitoring for congestive heart failure patients,” *Caring Magazine*, Aug. 1995: 53-54.
- Moser et al., “Improving outcomes in heart failure: it’s not unusual beyond usual Care,” *Circulation*. 2002;105:2810-2812.
- Nagels et al., “Actigraphic measurement of agitated behaviour in dementia,” *International journal of geriatric psychiatry*, 2009; 21(4):388-393. [Abstract Only].
- Nakamura et al., “Universal scaling law in human behavioral organization,” *Physical Review Letters*, Sep. 28, 2007; 99(13):138103 (4 pages).
- Nakaya, “Fractal properties of seismicity in regions affected by large, shallow earthquakes in western Japan: Implications for fault formation processes based on a binary fractal fracture network model,” *Journal of geophysical research*, Jan. 2005; 11(B1):B01310.1-B01310.15. [Abstract Only].

(56)

References Cited

OTHER PUBLICATIONS

- Naylor et al., "Comprehensive discharge planning for the hospitalized elderly: a randomized clinical trial," *Amer. College Physicians* 1994; 120(12):999-1006.
- Nesiritide (Natrecor), [Presentation] Acutely Decompensated Congestive Heart Failure: Burden of Disease, downloaded from the Internet: <<<http://www.huntsvillehospital.org/foundation/events/cardiologupdate/CHF.ppt>>>, 39 pages.
- Nieminen et al., "EuroHeart Failure Survey II (EHFS II): a survey on hospitalized acute heart failure patients: description of population," *European Heart Journal* 2006; 27(22):2725-2736.
- Nijssen et al., "The potential value of three-dimensional accelerometry for detection of motor seizures in severe epilepsy," *Epilepsy Behav.* Aug. 2005;7(1):74-84.
- Noble et al., "Diuretic induced change in lung water assessed by electrical impedance tomography," *Physiol. Meas.* 2000; 21(1):155-163.
- Noble et al., "Monitoring patients with left ventricular failure by electrical impedance tomography," *Eur J Heart Fail.* Dec. 1999;1(4):379-84.
- O'Connell et al., "Economic impact of heart failure in the United States: time for a different approach," *J Heart Lung Transplant.*, Jul.-Aug. 1994 ; 13(4):S107-S112.
- Ohlsson et al., "Central hemodynamic responses during serial exercise tests in heart failure patients using implantable hemodynamic monitors," *Eur J Heart Fail.* Jun. 2003;5(3):253-259.
- Ohlsson et al., "Continuous ambulatory monitoring of absolute right ventricular pressure and mixed venous oxygen saturation in patients with heart failure using an implantable haemodynamic monitor," *European Heart Journal* 2001 22(11):942-954.
- Packer et al., "Utility of impedance cardiography for the identification of short-term risk of clinical decompensation in stable patients with chronic heart failure," *J Am Coll Cardiol*, 2006; 47(11):2245-2252.
- Palatini et al., "Predictive value of clinic and ambulatory heart rate for mortality in elderly subjects with systolic hypertension" *Arch Intern Med.* 2002;162:2313-2321.
- Piirra et al., "Crackles in patients with fibrosing alveolitis bronchiectasis, COPD, and Heart Failure," *Chest* May 1991; 99(5):1076-1083.
- Pocock et al., "Predictors of mortality in patients with chronic heart failure," *Eur Heart J* 2006; (27): 65-75.
- Poole-Wilson, "Importance of control of fluid volumes in heart failure," *European Heart Journal* 2000; 22(11):893-894.
- Raj et al., "Letter Regarding Article by Adamson et al, "Continuous Autonomic Assessment in Patients With Symptomatic Heart Failure: Prognostic Value of Heart Rate Variability Measured by an Implanted Cardiac Resynchronization Device", *Circulation* 2005;112:e37-e38.
- Ramirez et al., "Prognostic value of hemodynamic findings from impedance cardiography in hypertensive stroke," *AJH* 2005; 18(20):65-72.
- Rich et al., "A multidisciplinary intervention to prevent the readmission of elderly patients with congestive heart failure," *New Engl. J. Med.* 1995;333:1190-1195.
- Roglieri et al., "Disease management interventions to improve outcomes in congestive heart failure," *Am J Manag Care.* Dec. 1997;3(12):1831-1839.
- Sahalos et al., "The Electrical impedance of the human thorax as a guide in evaluation of intrathoracic fluid volume," *Phys. Med. Biol.* 1986; 31:425-439.
- Saxon et al., "Remote active monitoring in patients with heart failure (rapid-rf): design and rationale," *Journal of Cardiac Failure* 2007; 13(4):241-246.
- Scharf et al., "Direct digital capture of pulse oximetry waveforms," *Proceedings of the Twelfth Southern Biomedical Engineering Conference*, 1993., pp. 230-232.
- Shabetai, "Monitoring heart failure hemodynamics with an implanted device: its potential to improve outcome," *J Am Coll Cardio*, 2003; 41:572-573.
- Small, "Integrating monitoring into the Infrastructure and Workflow of Routine Practice: OptiVol," *Rev Cardiovasc Med.* 2006 ;7 Suppl 1: S47-S55.
- Smith et al., "Outcomes in heart failure patients with preserved ejection fraction: mortality, readmission, and functional decline," *J Am Coll Cardiol*, 2003; 41:1510-1518.
- Something in the way he moves, *The Economist*, 2007, retrieved from the Internet: <<<http://www.economist.com/science/printerFriendly.cfm?story id=9861412>>>.
- Starling, "Improving care of chronic heart failure: advances from drugs to devices," *Cleveland Clinic Journal of Medicine* Feb. 2003; 70(2):141-146.
- Steijaert et al., "The use of multi-frequency impedance to determine total body water and extracellular water in obese and lean female individuals," *International Journal of Obesity* Oct. 1997; 21(10):930-934.
- Stewart et al., "Effects of a home-based intervention among patients with congestive heart failure discharged from acute hospital care," *Arch Intern Med.* 1998;158:1067-1072.
- Stewart et al., "Effects of a multidisciplinary, home-based intervention on planned readmissions and survival among patients with chronic congestive heart failure: a randomised controlled study," *The Lancet* Sep. 1999, 354(9184):1077-1083.
- Stewart et al., "Home-based intervention in congestive heart failure: long-term implications on readmission and survival," *Circulation.* 2002;105:2861-2866.
- Stewart et al., "Prolonged beneficial effects of a home-based intervention on unplanned readmissions and mortality among patients with congestive heart failure," *Arch Intern Med.* 1999;159:257-261.
- Stewart et al., "Trends in Hospitalization for Heart Failure in Scotland, 1990-1996. An Epidemic that has Reached Its Peak?," *European Heart Journal* 2001 22(3):209-217.
- Swedberg et al., "Guidelines for the diagnosis and treatment of chronic heart failure: executive summary (update 2005): The Task Force for the Diagnosis and Treatment of Chronic Heart Failure of the European Society of Cardiology," *Eur Heart J.* Jun. 2005; 26(11):1115-1140.
- Tang, "Case studies in advanced monitoring: OptiVol," *Rev Cardiovasc Med.* 2006;7 Suppl 1:S62-S66.
- The ESCAPE Investigators and ESCAPE Study Coordinators, "Evaluation Study of Congestive Heart Failure and Pulmonary Artery Catheterization Effectiveness," *JAMA* 2005;294:1625-1633.
- Tosi et al., "Seismic signal detection by fractal dimension analysis," *Bulletin of the Seismological Society of America*; Aug. 1999; 89(4):970-977. [Abstract Only].
- Van De Water et al., "Monitoring the chest with impedance," *Chest.* 1973;64:597-603.
- Van Someren, "Actigraphic monitoring of movement and rest-activity rhythms in aging, Alzheimer's disease, and Parkinson's disease," *IEEE Transactions on Rehabilitation Engineering*, Dec. 1997; 5(4):394-398. [Abstract Only].
- Vasan et al., "Congestive heart failure in subjects with normal versus reduced left ventricular ejection fraction," *J Am Coll Cardiol*, 1999; 33:1948-1955.
- Verdecchia et al., "Adverse prognostic value of a blunted circadian rhythm of heart rate in essential hypertension," *Journal of Hypertension* 1998; 16(9):1335-1343.
- Verdecchia et al., "Ambulatory pulse pressure: a potent predictor of total cardiovascular risk in hypertension," *Hypertension.* 1998;32:983-988.
- Vollmann et al., "Clinical utility of intrathoracic impedance monitoring to alert patients with an implanted device of deteriorating chronic heart failure," *European Heart Journal Advance Access* published on Feb. 19, 2007, downloaded from the Internet: <<<http://eurheartj.oxfordjournals.org/cgi/content/full/eh1506v1>>>, 6 pages total.
- Vuksanovic et al., "Effect of posture on heart rate variability spectral measures in children and young adults with heart disease," *International Journal of Cardiology* 2005;101(2): 273-278.
- Wang et al., "Feasibility of using an implantable system to measure thoracic congestion in an ambulatory chronic heart failure canine model," *PACE* 2005;28(5):404-411.

(56)

References Cited

OTHER PUBLICATIONS

Wickemeyer et al., #197 —“Association between atrial and ventricular tachyarrhythmias, intrathoracic impedance and heart failure decompensation in CRT-D Patients,” *Journal of Cardiac Failure* 2007; 13 (6) Suppl.; S131-132.

Williams et al., “How do different indicators of cardiac pump function impact upon the long-term prognosis of patients with chronic heart failure,” *American Heart Journal*, 150(5):983.e1-983.e6.

Wonisch et al., “Continuous haemodynamic monitoring during exercise in patients with pulmonary hypertension,” *Int J Cardiol*. Jun. 8, 2005;101(3):415-420.

Wynne et al., “Impedance cardiography: a potential monitor for hemodialysis,” *Journal of Surgical Research* 2006, 133(1):55-60.

Yancy “Current approaches to monitoring and management of heart failure,” *Rev Cardiovasc Med* 2006; 7 Suppl 1:S25-32.

Ypenburg et al., “Intrathoracic Impedance Monitoring to Predict Decompensated Heart Failure,” *Am J Cardiol* 2007, 99(4):554-557.

Yu et al., “Intrathoracic Impedance Monitoring in Patients With Heart Failure: Correlation With Fluid Status and Feasibility of Early Warning Preceding Hospitalization,” *Circulation*. 2005;112:841-848.

Zannad et al., “Incidence, clinical and etiologic features, and outcomes of advanced chronic heart failure: The EPICAL Study,” *J Am Coll Cardiol*, 1999; 33(3):734-742.

Zile, “Heart failure with preserved ejection fraction: is this diastolic heart failure?” *J Am Coll Cardiol*, 2003; 41(9):1519-1522.

U.S. Appl. No. 60/006,600, filed Nov. 13, 1995; inventor: Terry E. Flach.

U.S. Appl. No. 60/972,316, filed Sep. 12, 2008; inventor: Imad Libbus et al.

U.S. Appl. No. 60/972,329, filed Sep. 14, 2007; inventor: Yatheendhar Manicka et al.

U.S. Appl. No. 60/972,333, filed Sep. 14, 2007; inventor: Mark Bly et al.

U.S. Appl. No. 60/972,336, filed Sep. 14, 2007; inventor: James Kristofer et al.

U.S. Appl. No. 60/972,340, filed Sep. 14, 2007; inventor: James Kristofer et al.

U.S. Appl. No. 60/972,343, filed Sep. 14, 2007; inventor: James Kristofer et al.

U.S. Appl. No. 60/972,354, filed Sep. 14, 2007; inventor: Scott Thomas Mazar et al.

U.S. Appl. No. 60/972,359, filed Sep. 14, 2007; inventor: Badri Amurthur et al.

U.S. Appl. No. 60/972,363, filed Sep. 14, 2007; inventor: Badri Amurthur et al.

U.S. Appl. No. 60/972,512, filed Sep. 14, 2007; inventor: Imad Libbus et al.

U.S. Appl. No. 60/972,537 filed Sep. 14, 2007; inventor: Yatheendhar Manicka et al.

U.S. Appl. No. 60/972,581, filed Sep. 14, 2007; inventor: Imad Libbus et al.

U.S. Appl. No. 60/972,616, filed Sep. 14, 2007; inventor: Imad Libbus et al.

U.S. Appl. No. 60/972,629, filed Sep. 14, 2007; inventor: Mark Bly et al.

U.S. Appl. No. 61/035,970, filed Mar. 12, 2008; inventor: Imad Libbus et al.

U.S. Appl. No. 61/046,196 filed Apr. 18, 2008; inventor: Scott T. Mazar.

U.S. Appl. No. 61/047,875, filed Apr. 25, 2008; inventor: Imad Libbus et al.

U.S. Appl. No. 61/055,645, filed May 23, 2008; inventor: Mark Bly et al.

U.S. Appl. No. 61/055,656, filed May 23, 2008; inventor: Imad Libbus et al.

U.S. Appl. No. 61/055,666, filed May 23, 2008; inventor: Yatheendhar Manicka et al.

U.S. Appl. No. 61/084,567, filed Jul. 29, 2008; inventor: Mark Bly.

* cited by examiner

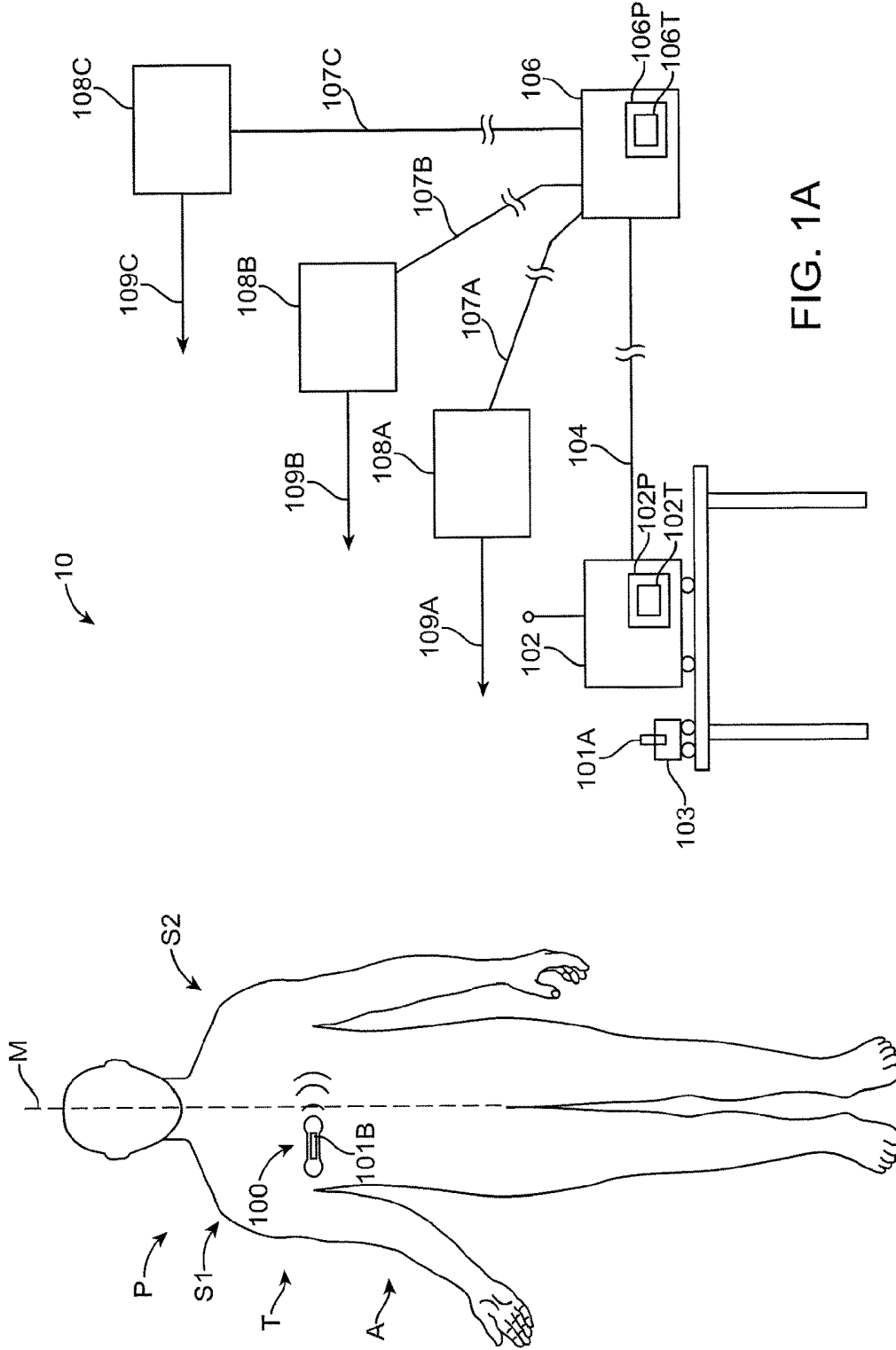

FIG. 1A

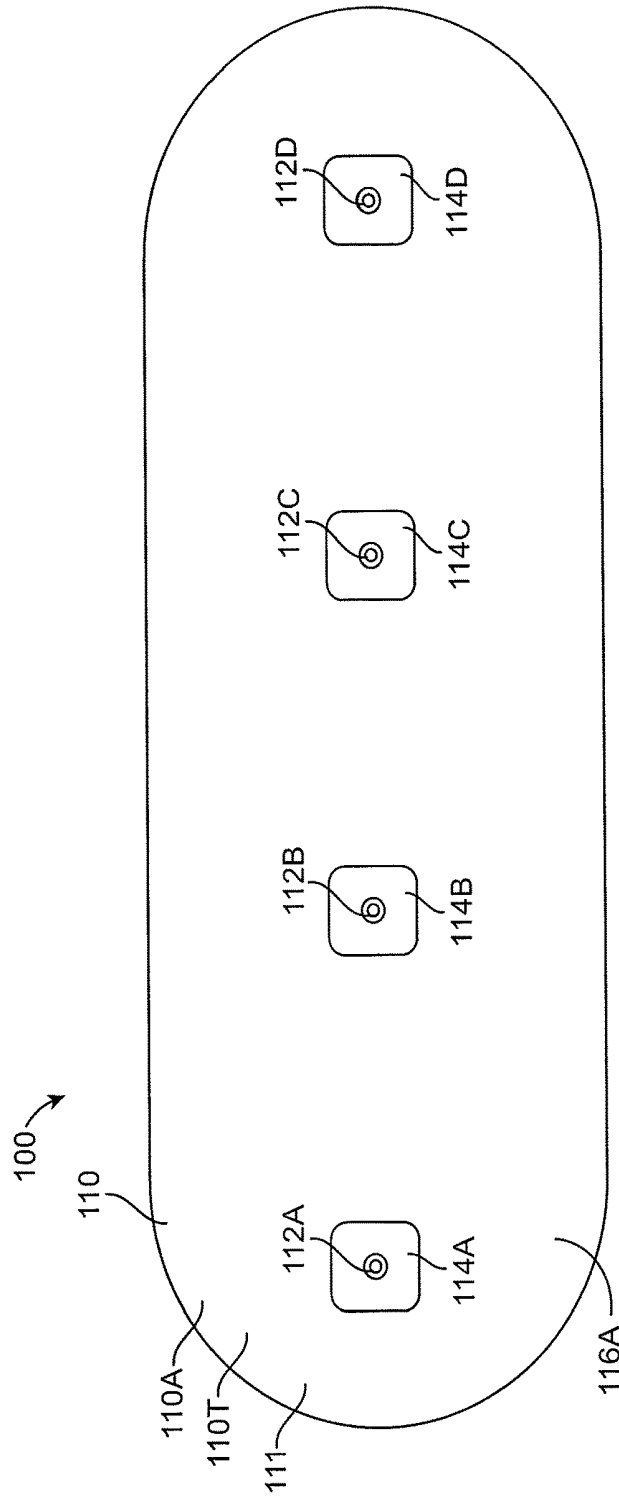

FIG. 1B

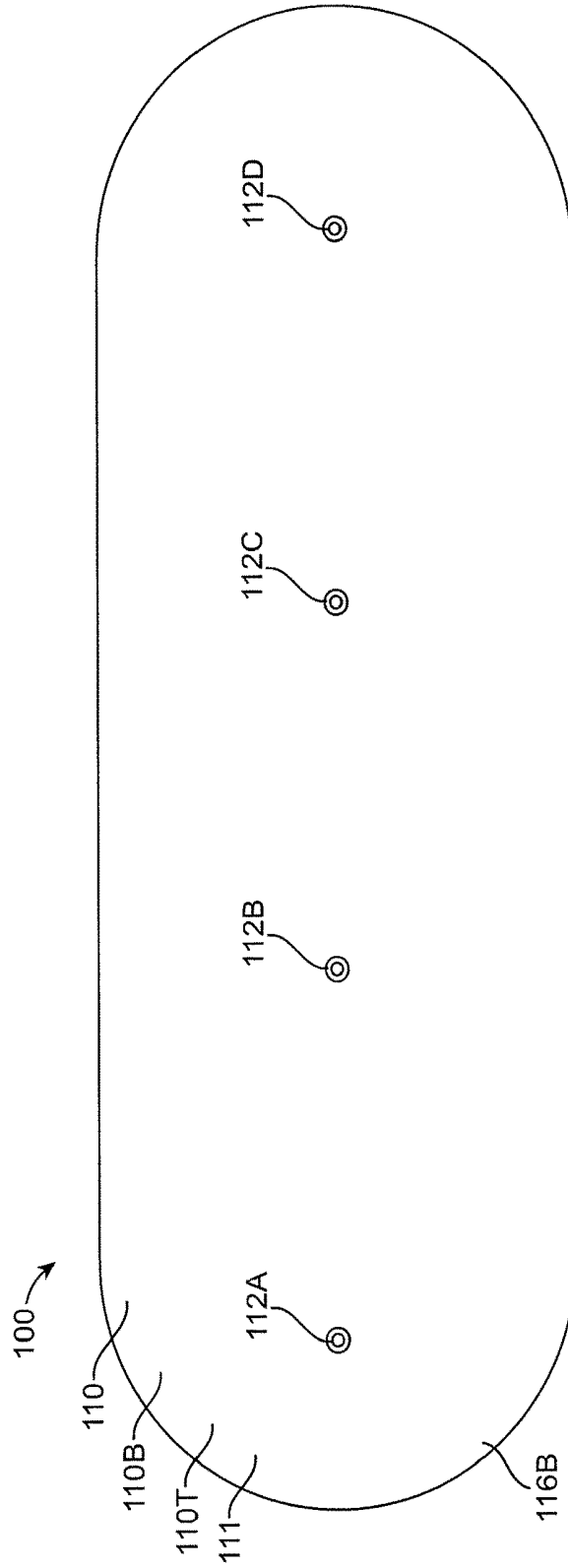

FIG. 1C

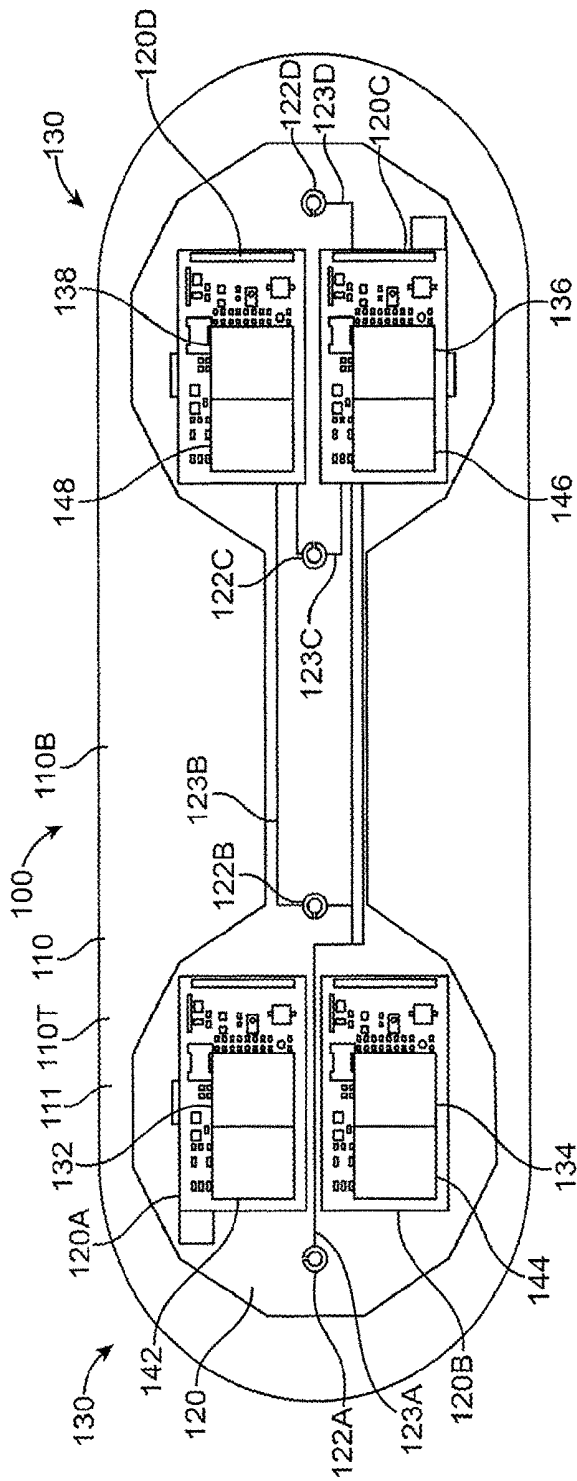

FIG. 1D

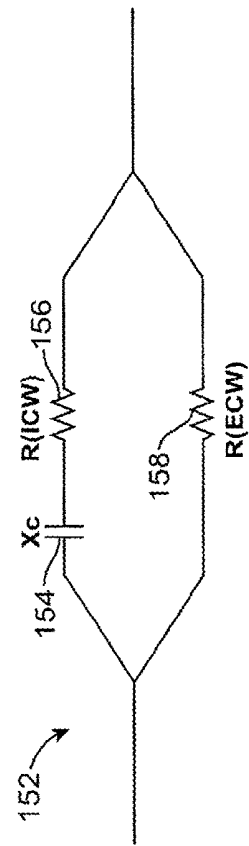

FIG. 1D1

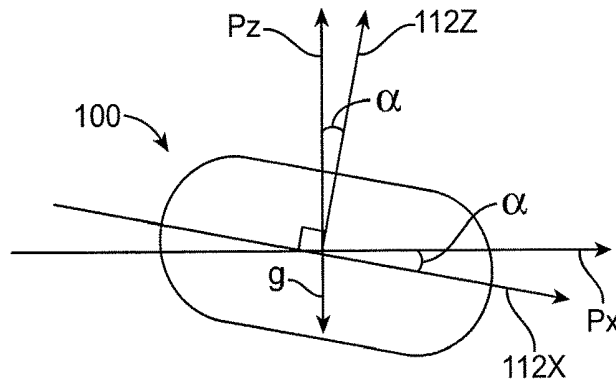

FIG. 1D2

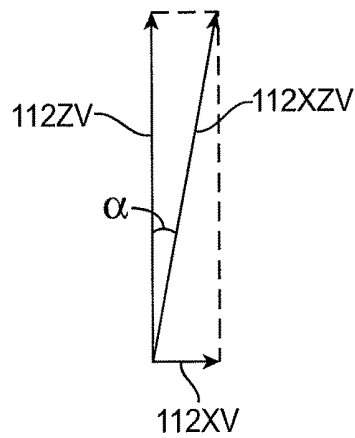

FIG. 1D3

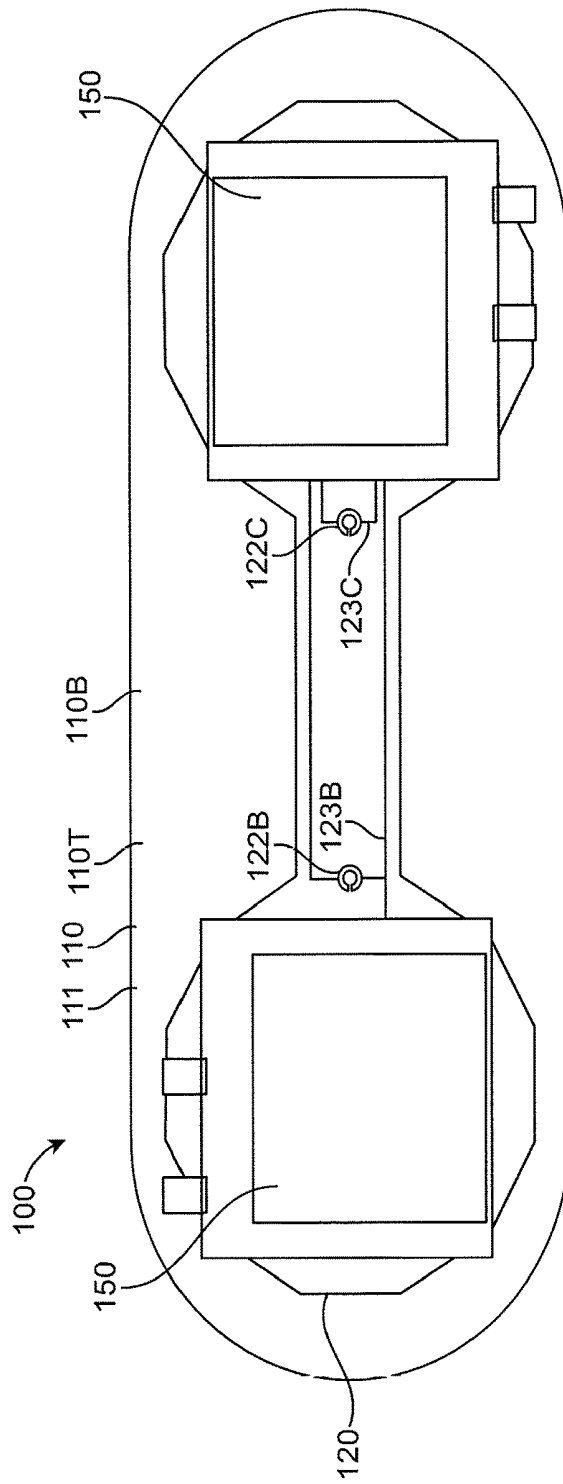

FIG. 1E

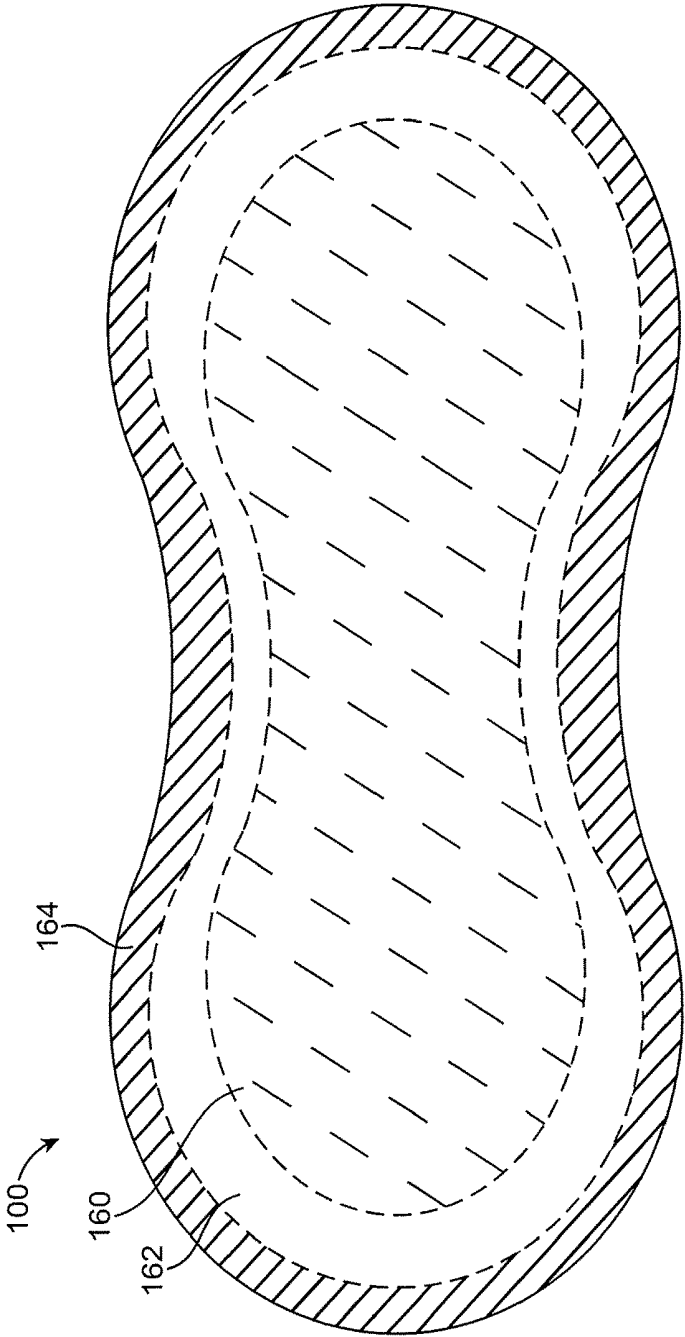

FIG. 1F

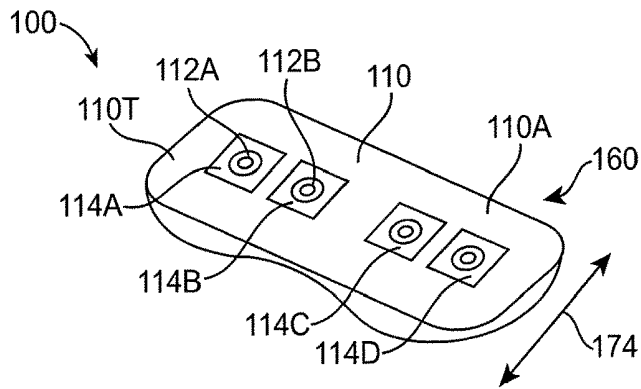

FIG. 1H

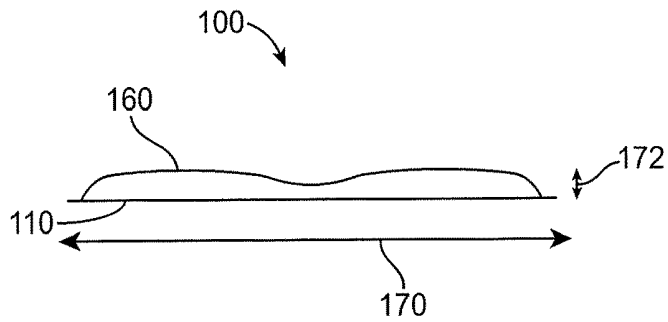

FIG. 1G

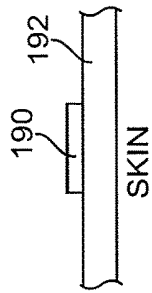

FIG. 1K

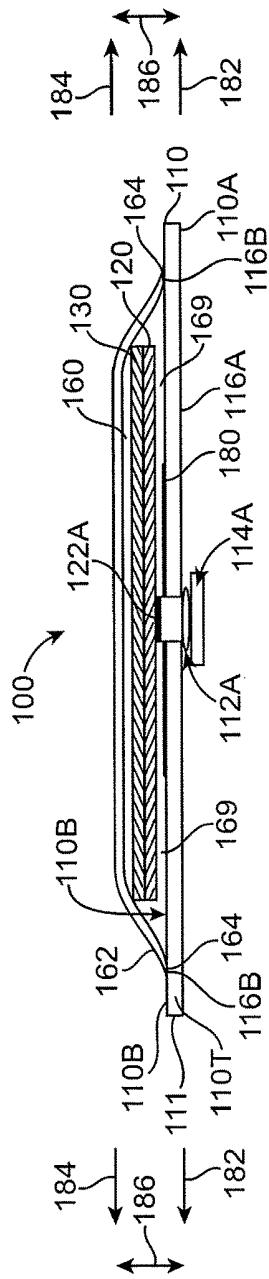

FIG. 1I

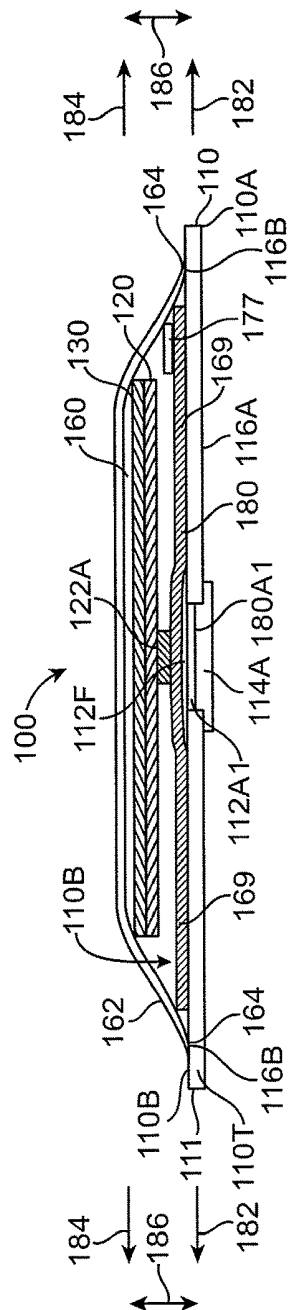

FIG. 1I1

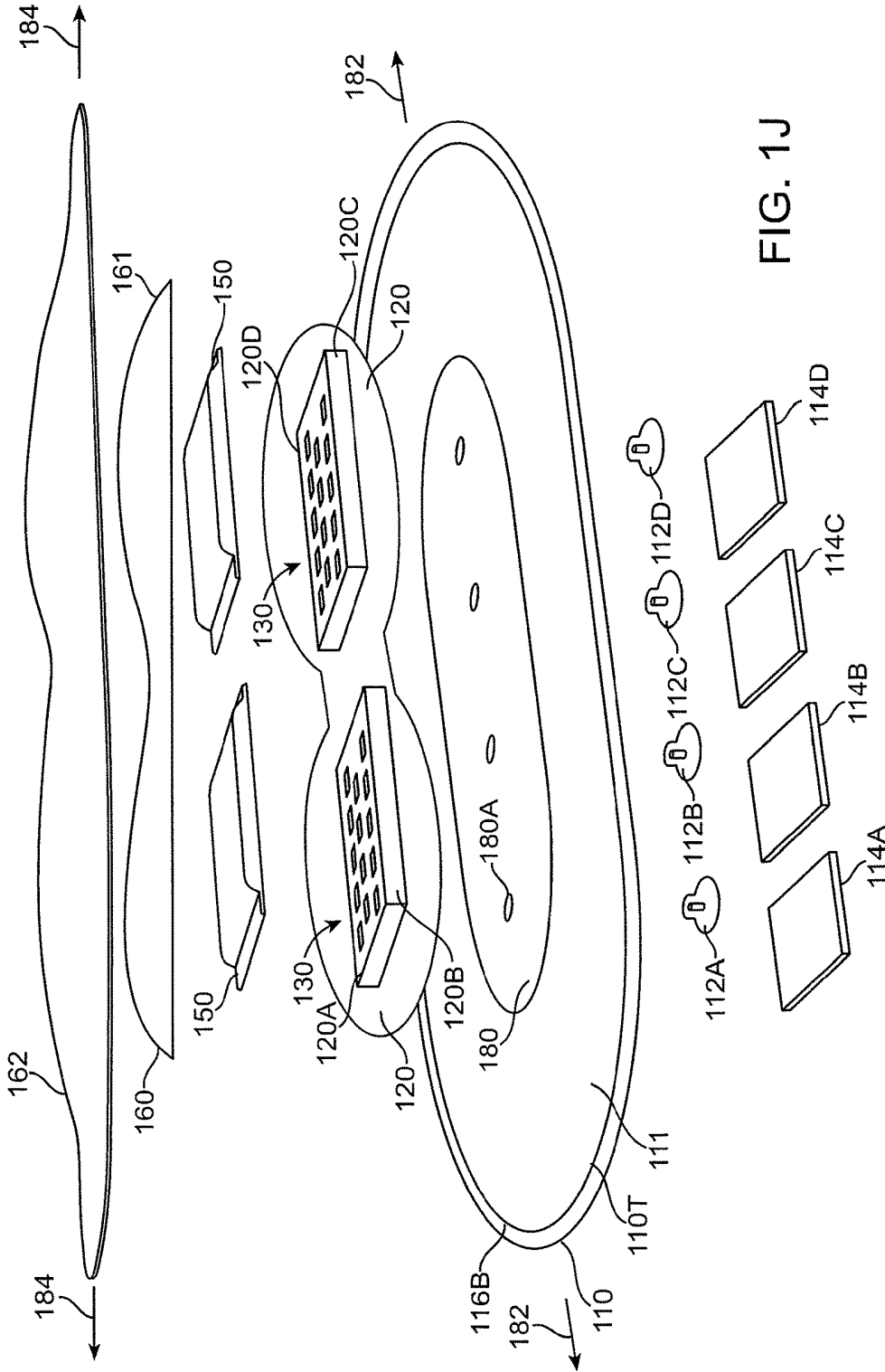
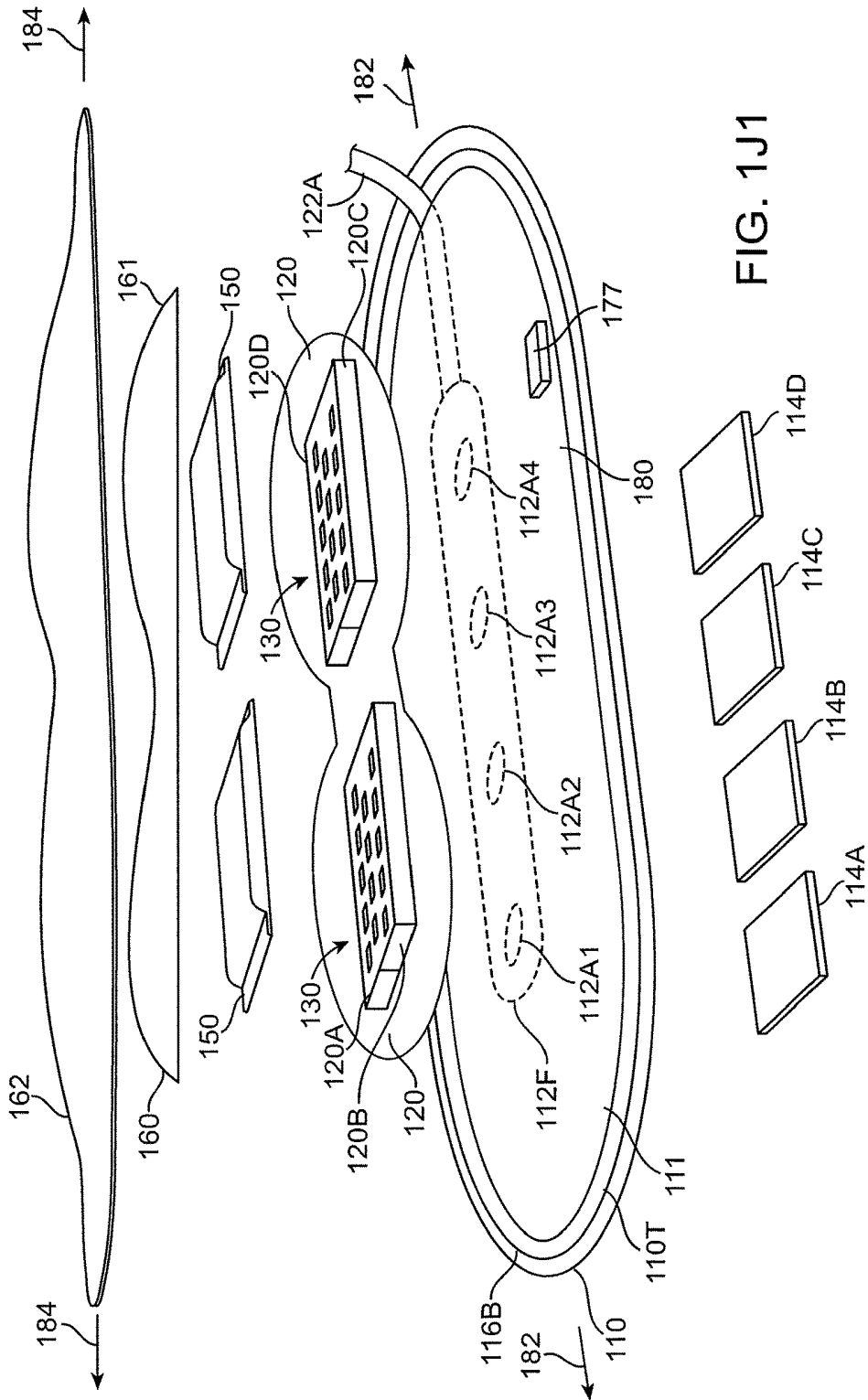
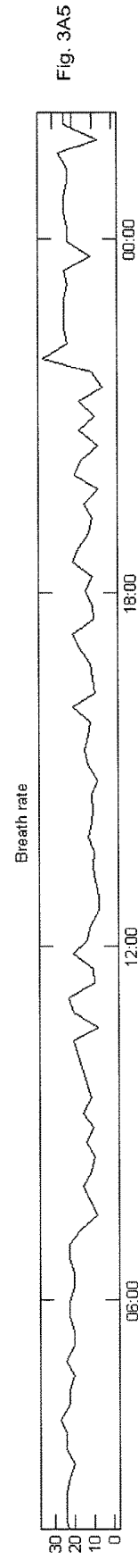
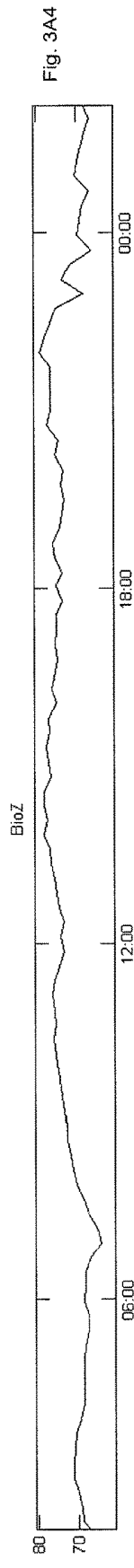
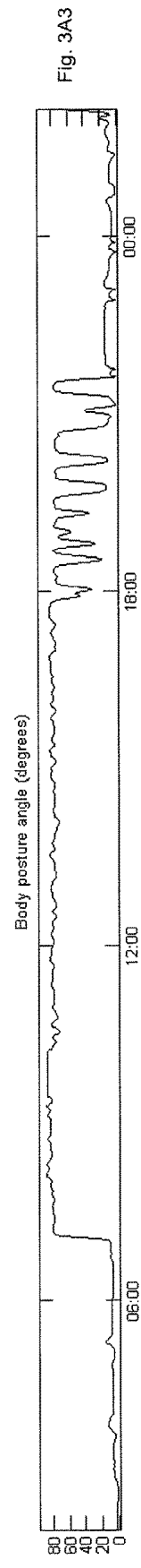
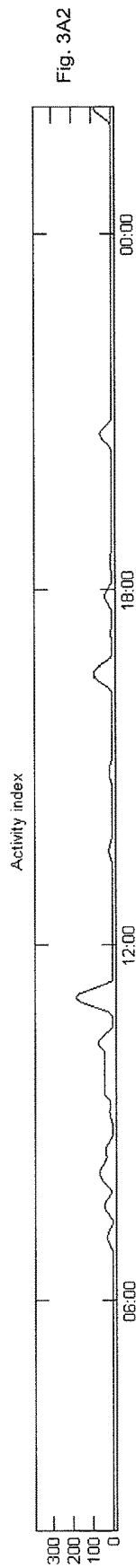
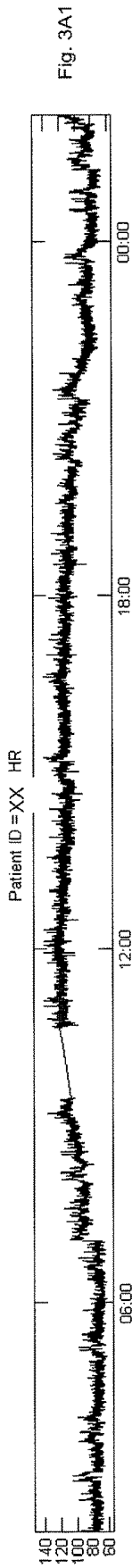

FIG. 1J



- 200- Method of monitoring a patient
- 205- Adhere measurement device to patient to measure heart rate, activity, body posture, respiration rate and bioimpedance
- 210- Measure, store and process patient data with adherent device
- 212- Determine patient drug treatment
- 215- Transmit patient data from adherent device to gateway
- 220- Receive patient data with gateway
- 225- Measure, store and process patient data with gateway
- 230- Transmit patient data from gateway to remote server
- 235- Measure, store and process patient data with remote server
- 240- Identify CI with profile of remote heart rates
 - 241- determine profile of remote heart rates
 - 242- determine peak of profile of remote heart rates
 - 243- determine portion of profile above peak
 - 244- determine portion of profile below peak
 - 245- compare portion above peak to portion below peak
 - 246- identify CI when portion above peak is less than portion below
- 250- Identify CI with resting remote HR
 - 251- determine occurrence of heart rates corresponding to profile
 - 252- determine peak of the remote heart rates
 - 253- determine peak of remote heart rates
 - 254- determine remote resting HR based on peak of remote HR
 - 255- determine age corrected maximum HR
 - 256- determine HRR based on age corrected maximum HR and remote resting HR
 - 257- identify CI when HRR below threshold
- 260- Identify CI with maximum HR
 - 261- determine threshold activity amount based on patient data from a plurality of other patients
 - 262- determine patient activity above threshold
 - 263- determine heart rates corresponding to patient activity above threshold
 - 264- determine correlation of HR above threshold with one or more of activity, body posture, respiration rate and bioimpedance
 - 265- determine patient drug treatment and compliance
 - 266- determine CI based on patient drug treatment and correlation of HR above threshold with the one or more of one or more of activity, body posture, respiration rate and bioimpedance
- 270- Transmit notification to one or more of physician or patient based on identification of CI

Figure 2



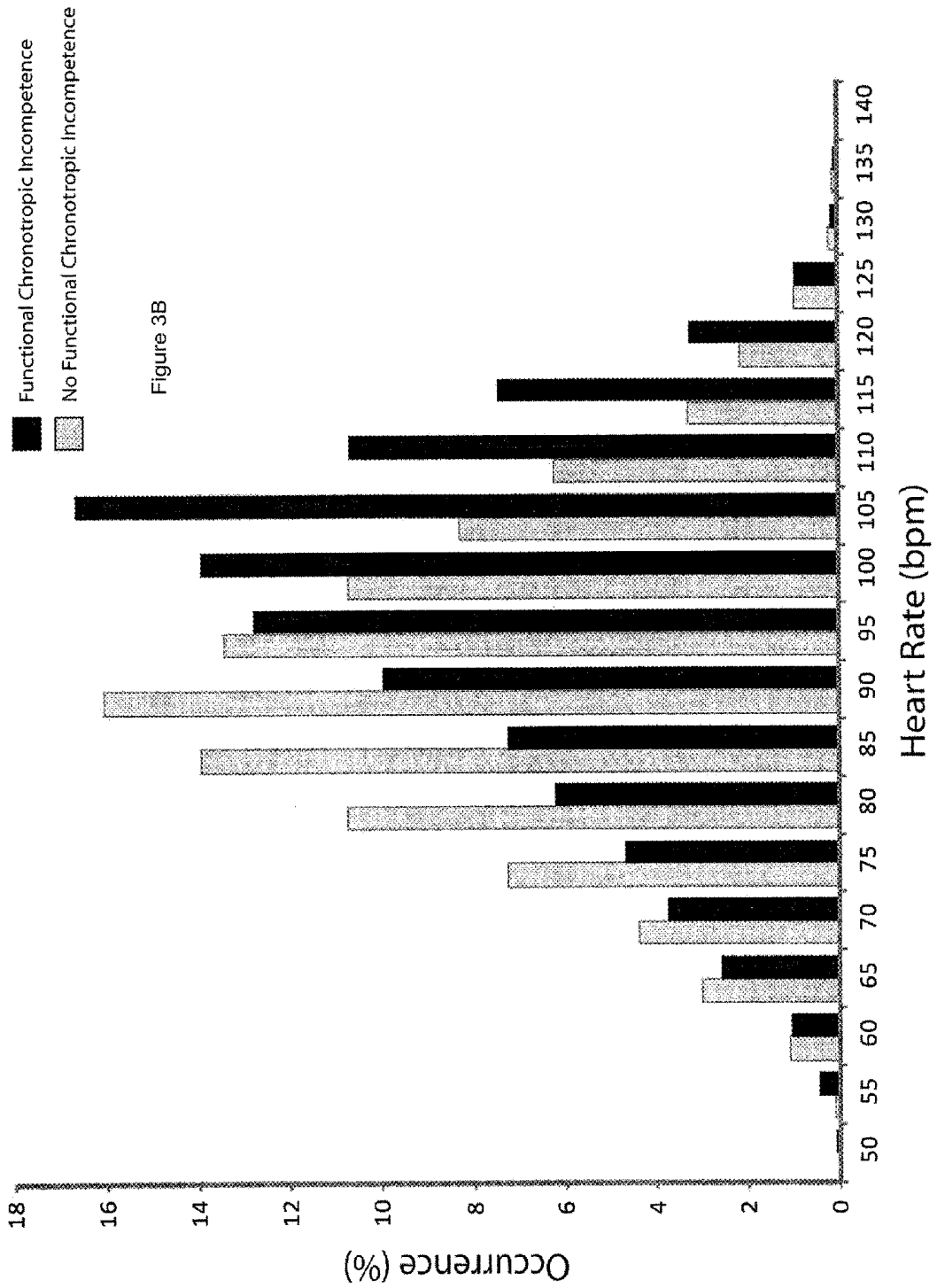

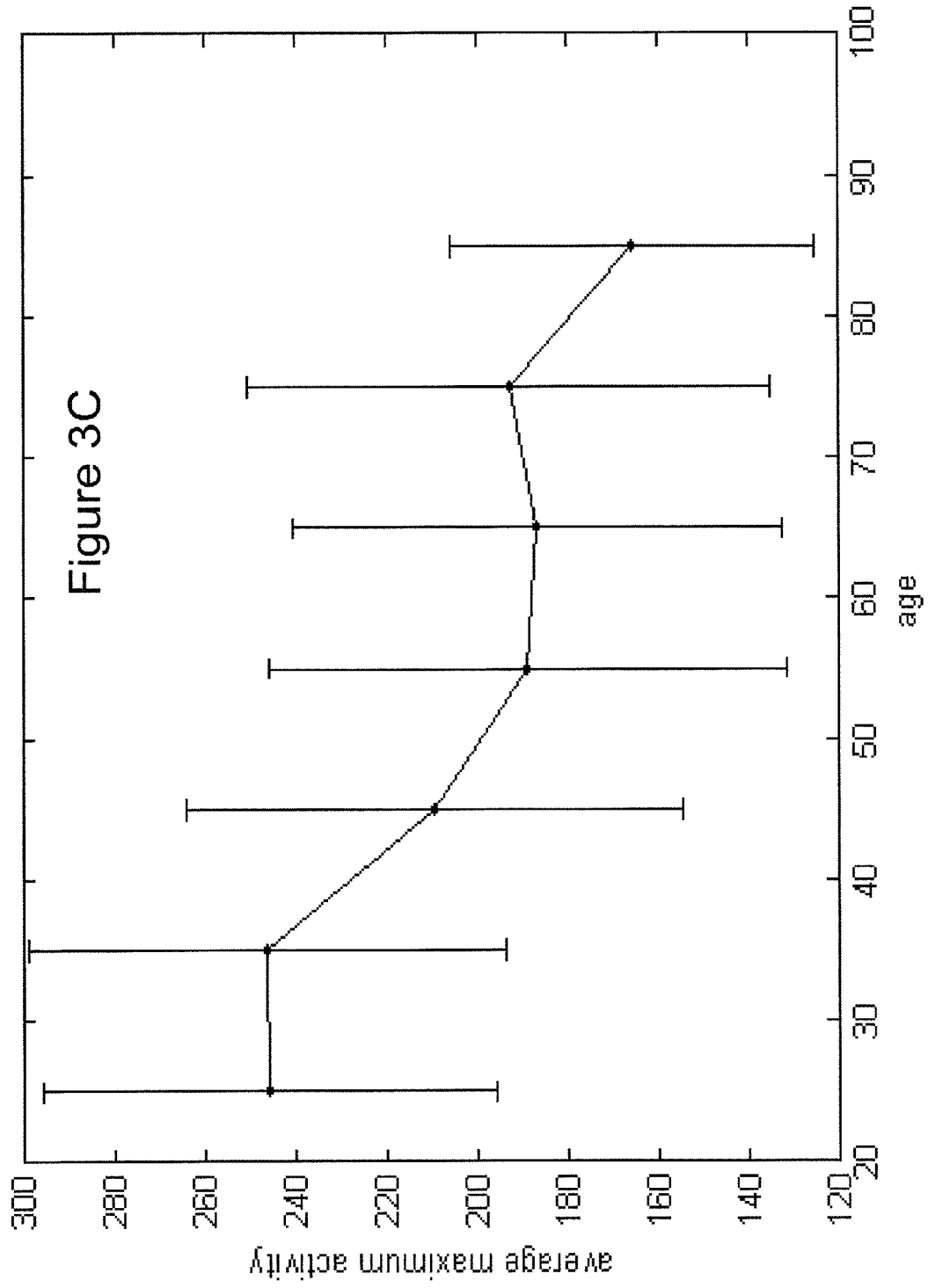

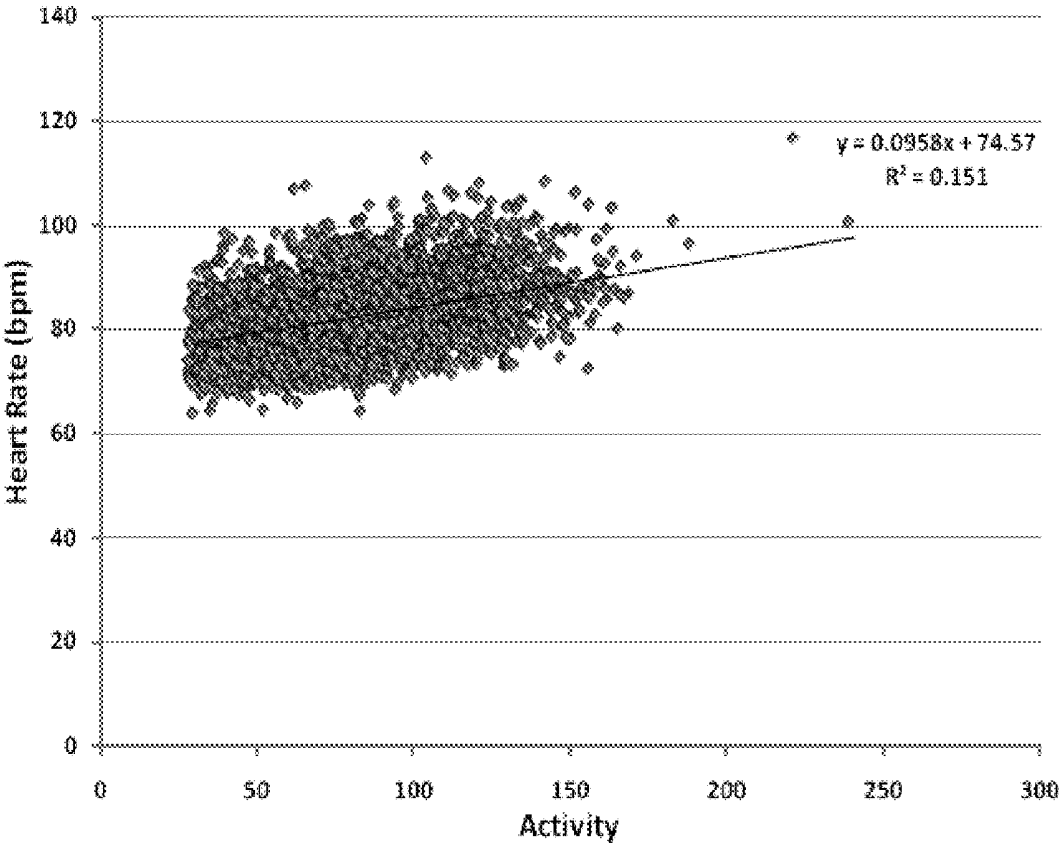

FIGURE 3D1

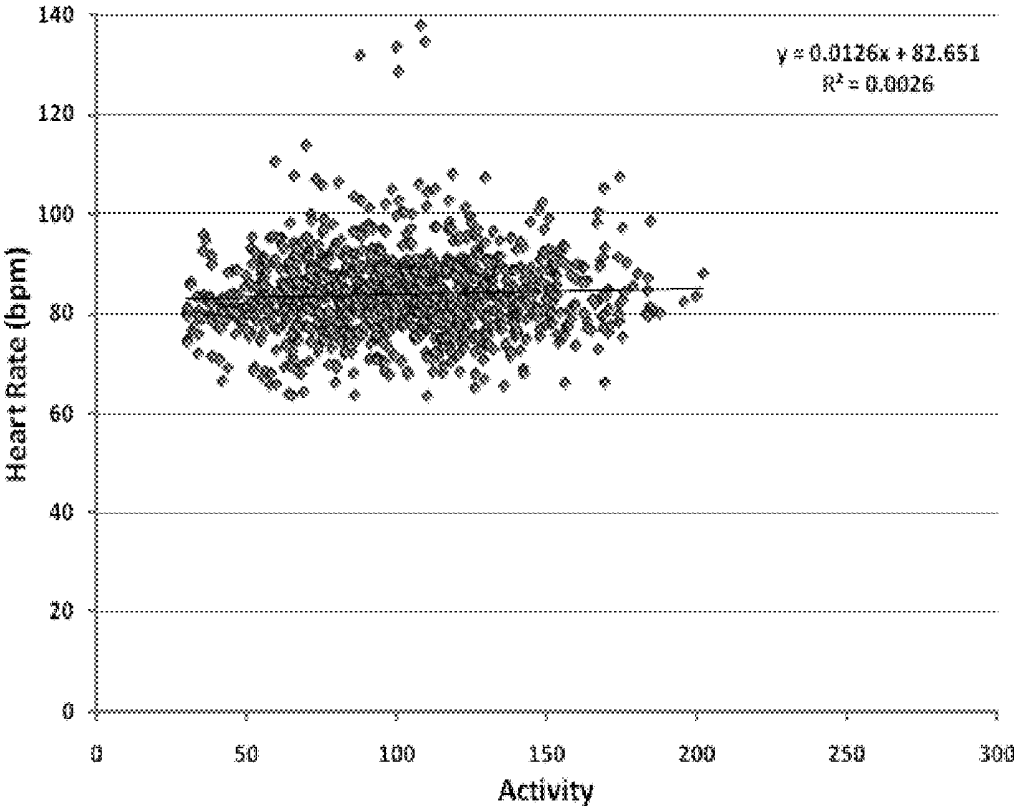

FIGURE 3D2

**METHOD AND APPARATUS FOR REMOTE
DETECTION AND MONITORING OF
FUNCTIONAL CHRONOTROPIC
INCOMPETENCE**

CROSS-REFERENCES TO RELATED
APPLICATIONS

The present application is a non-provisional and claims to priority to the following provisional patent application: U.S. 61/253,866, filed on Oct. 22, 2009, entitled "Method and Apparatus for Remote Detection and Monitoring of Functional Chronotropic Incompetence".

BACKGROUND OF THE INVENTION

Patients are often treated for diseases and/or conditions associated with a compromised status of the patient, for example a compromised physiologic status. In some instances, a patient may report symptoms that require diagnosis to determine the underlying cause. For example, a patient may report fainting or dizziness that requires diagnosis, in which long term monitoring of the patient can provide useful information as to the physiologic status of the patient. In some instances a patient may have suffered a heart attack and require care and/or monitoring after release from the hospital.

Chronotropic incompetence (hereinafter "CI") can be a debilitating condition associated with high mortality and morbidity. Chronotropic incompetence can be defined as the inability for a patient to elevate heart rate to 85% of the age-predicted maximum heart rate (hereinafter "APMHR") level during exercise in a clinical environment. The determination of the ability of the patient to raise HR can be done by subjecting a patient to exercise in a clinic to elevate the patient HR, for example with a treadmill in a clinic.

Work in relation to embodiments of the present invention suggests that known methods and apparatus for determining CI may be less than ideal. At least some of the known methods and apparatus test the patient in a clinical setting and may not determine the presence of CI when the patient is located remote from the clinic, for example located at home. Although successful in determining the presence of CI in a clinical setting, current methods that rely on a controlled environment such as a treadmill in a clinic may not be well suited to determine CI when the patient is located remote from the clinic. For example, in at least some instances the patient may be somewhat frail and not well suited to exercise on his or her own. Also, current methods of determining the maximum HR of the patient assume that the patient is able to exercise the level of his or her capacity when the maximum HR is measured, and in at least some instances such an assumption may not be appropriate, such as for patients with respiratory and cardiac diseases, as well as patients with physical disability.

Another approach to determining cardiac function related to CI in a patient can be to determine the heart rate reserve (hereinafter "HRR") of the patient, in which the HRR is determined with the resting HR of the patient. However, in at least some instances it can be difficult to determine the resting HR of the patient in the clinic. In at least some instances, measurements of a patient in a clinic can be nervous and the heart rate can be elevated, for example with white coat syndrome, and the patient may receive an incorrect diagnosis in at least some instances. Further, at least some of the present methods of measuring HR remotely may not provide appro-

priate data to determine the resting HR when the patient is located remote from the clinic.

Therefore, a need exists for improved patient monitoring. Ideally, such improved patient monitoring would avoid at least some of the short-comings of the present methods and devices.

BRIEF SUMMARY OF THE INVENTION

Embodiments of the present invention provide methods and apparatus to determine the presence of and track functional CI in an in-home setting under conditions of daily living. The remote monitoring of the patient can determine the presence of functional CI and identify functional CI so as to allow appropriate intervention and treatment. The functional CI of the patient can be determined safely and in many ways with the patient located outside the clinic. For example, the functional CI of the patient may be determined with one or more of a profile of measured patient heart rates, a measured maximum patient heart rate, or a peak of the heart rate profile, such as the peak of a heart rate distribution profile. The functional CI of the patient may be determined with the measured heart rate profile, in which the measured heart rate profile may correspond to heart rates substantially less than the maximum heart rate of the patient, such that the heart rate can be safely measured when the patient is remote from a health care provider. Alternatively or in combination, the functional CI of the patient may be determined based on a peak of the remotely measured heart rate profile. Further, the functional CI may be determined based on statistical measurements of the heart rate profile such as a location, for example central tendency, and variability, for example dispersion, of the measured heart rate. For example, the relative amounts of the profile of heart rates above the peak and heart rates below the peak can be compared to determine the functional CI. The peak of the heart rate profile of the remote heart rate data may be used to determine the heart rate reserve and functional CI of the patient.

The measured distribution of heart rates of the remotely measured patient heart rate data can be combined with one or more of the measured activity data, measured respiration data, the measured orientation and the measured impedance data so as to determine the functional CI of the patient. The measured activity data of the patient can be combined with the heart rate data to determine a measured maximum heart rate of the patient when the patient exercises. For example, the peak activity of the patient can be determined and compared to a threshold value, and the maximum heart rate of the patient may correspond to the activity of the patient above the threshold. Alternatively or in combination, the maximum heart rate of the patient may comprise an estimated maximum heart rate of the patient, and the presence of functional CI determined based on the estimated maximum heart rate and the age predicted maximum heart rate, such that the functional CI may be determined without requiring elevation of the heart rate of the patient.

The measured patient data can come from one or more of many sources of data such as an adherent device, or an implantable device, or combinations thereof. An implantable device can be used to measure heart rate data. Alternatively or in combination an adherent device can be used to measure heart rate data. Additional data can be measured, for example accelerometer data from an adherent device.

In a first aspect, embodiments provide an apparatus to monitor a patient. A processor system comprises at least one processor having a tangible medium with instructions of a computer program embodied thereon, the processor system

configured to receive heart rate data of the patient and determine a profile of the heart rates and wherein the processor is configured to identify chronotropic incompetence of the patient based on the profile of the heart rates.

In many embodiments, the computer program comprises instructions to identify the functional CI with one or more measurement of location of the heart rate data, measures of dispersion and variability of the heart rate data, skewness and kurtosis of the heart rate data, or comparison of portions around a mode of a single modal mounded distribution.

In many embodiments, the computer program comprises instructions to determine a peak of the profile and a first portion of the profile and a second portion of the profile, the first portion corresponding to a first amount of occurrences of first heart rates less than the peak and the second portion corresponding to a second amount of occurrences of second heart rates greater than the peak and wherein the chronotropic incompetence is identified based on the second amount smaller than the first amount.

In another aspect, embodiments provide an apparatus to monitor a remote patient, the apparatus comprises a processor system comprising at least one processor having a tangible medium with instructions of a computer program embodied thereon. The processor system is configured to receive heart rate data of the remote patient and determine a distribution of the heart rates, and the processor is configured to identify a chronotropic incompetence of the patient based on the distribution of heart rates.

In many embodiments, the computer program comprises instructions to receive respiration data of the patient and activity data of the patient and instructions to combine the heart rate data with the respiration data and activity data to identify the chronotropic incompetence.

In many embodiments, the computer program comprises instructions to determine a peak of the distribution and a first portion of the distribution and a second portion of the distribution, the first portion corresponding to a first amount of occurrences of first heart rates less than the peak and the second portion of the distribution corresponding to a second amount of occurrences of second heart rates greater than the peak. The chronotropic incompetence is identified based on the second amount smaller than the first amount.

In another aspect, embodiments provide a method of monitoring a patient. A processor system is provided which comprises at least one processor having a tangible medium with instructions of a computer program embodied thereon, the processor system configured to receive heart rate data of the patient and determine a profile of the heart rates. The chronotropic incompetence of the patient is identified based on the profile of the heart rates.

In another aspect, embodiments provide an apparatus to monitor a remote patient. A processor system comprises at least one processor having a tangible medium with instructions of a computer program embodied thereon, the processor system configured to receive data of the remote patient comprising heart rate data of the patient and activity data of the patient. The processor system comprises instructions to determine activity of the patient to a threshold activity amount, and the processor system comprises instructions to identify a chronotropic incompetence of the patient based on the heart rate data corresponding to activity of the patient above the threshold.

In many embodiments, the processor system comprises instructions to determine a maximum heart rate of the heart rate data corresponding to the activity of the patient above the threshold.

In many embodiments, the processor system comprises instructions to determine a correlation of the maximum heart rate with one or more of the patient activity, patient body posture, patient breath rate or patient respiration rate and wherein the processor system is configured to identify CI based on the correlation.

In many embodiments, the data of the patient comprises drug data of the patient and wherein the processor system comprises instructions to identify CI based on the drug data and the correlation.

In many embodiments, the patient data comprises data from an adherent device measured remotely and wherein the processor system comprises instructions to determine the threshold amount from a plurality of remote patients and corresponds to a percentile of patient activity of the plurality of remote patients.

In another aspect, embodiments provide a method of monitoring a remote patient. A processor system is provided that comprises at least one processor having a tangible medium with instructions of a computer program embodied thereon, and the processor system is configured to receive data of the remote patient comprising heart rate data of the patient and activity data of the patient. The processor system comprises instructions to determine activity of the patient to a threshold activity amount. A chronotropic incompetence of the patient is identified based on the heart rate data corresponding to activity of the patient above the threshold.

In another aspect, embodiments provide an apparatus to monitor a remote patient. A processor system comprises at least one processor having a tangible medium with instructions of a computer program embodied thereon, and the processor system comprises instructions to receive heart rate data of the remote patient and to determine a peak of heart rates of the remote patient. The processor system comprises instructions to identify a chronotropic incompetence of the patient based on the peak.

In many embodiments, the heart rates comprise a profile of heart rates, and the peak comprises a peak of the profile.

In many embodiments, the heart rates comprise a distribution of heart rates, and the peak comprises a mode of the distribution.

In many embodiments, the processor system comprises instructions to determine a heart rate reserve based on a difference of a maximum age predicted maximum heart rate and the peak, and the processor system is configured to determine the CI based on the heart rate reserve determined with the peak.

In another aspect, embodiments provide a method of monitoring a remote patient. A processor system is provided that comprises at least one processor having a tangible medium with instructions of a computer program embodied thereon, and the processor system comprises instructions to receive heart rate data of the remote patient and to determine a peak of heart rates of the remote patient. A chronotropic incompetence of the patient is identified based on the peak.

In another aspect, embodiments provide an apparatus to monitor a patient having a skin. An adherent device to measure patient data comprises wireless communication circuitry and measurement circuitry, the measurement circuitry is coupled to at least two electrodes, a respiration sensor and an activity sensor. The adherent device comprising a support with an adhesive to adhere the at least two electrodes to the skin and support the wireless communication circuitry, the processor circuitry and the measurement circuitry with the skin. A server is located remote from the patient to receive the patient data. A gateway is coupled to each of the adherent device and the server with wireless communication to trans-

mit the patient data. One or more of the adherent device, the server or the gateway comprises at least one processor having a tangible memory medium with instructions of a computer program embodied thereon to determine a chronotropic incompetence of the patient based on the patient data measured with the at least two electrodes, the respiration sensor and the activity sensor.

In many embodiments, the at least one processor comprises instructions to determine a distribution of heart rates of the patient and wherein the at least one processor is configured to determine the chronotropic incompetence based on the distribution heart rates.

In many embodiments, the distribution of heart rates of the patient corresponds to a plurality of heart levels and an occurrence of each level.

In many embodiments, the computer program comprises instructions to determine a peak of the distribution and a first portion of the distribution and a second portion of the distribution, the first portion corresponding to a first amount of occurrences of first heart rates less than the peak and the second portion of the distribution corresponding to a second amount of occurrences of second heart rates greater than the peak and wherein the chronotropic incompetence is determined based on the second amount smaller than the first amount.

In many embodiments, the at least one processor comprises instructions to fit the distribution to a Gaussian distribution and determine a skew of the distribution and wherein the chronotropic incompetence is determined based on the skew.

In many embodiments, the at least one processor comprises instructions to determine a distribution of heart rates of the patient, the distribution corresponding heart rates less than a maximum heart rate of the patient and wherein the at least one processor is configured to determine the chronotropic incompetence based on the distribution heart rate intervals corresponding to less than the maximum heart rate of the patient.

In many embodiments, the at least one processor comprises instructions to determine a distribution of heart rates of the patient, the distribution corresponding to heart rates less than a maximum heart rate of the patient and wherein the at least one processor comprises instructions to determine the maximum heart rate of the patient based on the distribution heart rate intervals corresponding to less than the maximum heart rate of the patient.

In many embodiments, the at least one processor comprises instructions to determine the chronotropic incompetence of the patient based on the maximum heart rate of the patient.

In many embodiments, the at least one processor comprises instructions to determine the maximum heart rate of the patient based on the distribution of heart rates corresponding to less than the maximum heart rate of the patient.

In another aspect, embodiments provide a method of monitoring a patient. Heart rate data of the patient is measured. A processor system is provided which comprises at least one processor having a tangible medium with instructions of a computer program embodied thereon. The processor system receives heart rate data of the patient and determines a distribution of the heart rates, and the processor determines a chronotropic incompetence of the patient based on the distribution of heart rates.

In many embodiments, the heart rate data comprise data measured from a patch adhered to the patient for at least about one week, and the heart rate data is transmitted with wireless communication.

In another aspect, embodiments provide an apparatus to monitor a patient. The apparatus comprises an adherent device means for measuring patient data, and a processor

means for determining a chronotropic incompetence of the patient. The adherent device means may comprise the adherent device as described herein and the processor means for determining the chronotropic incompetence of the patient may comprise the computer readable instructions embedded on one or more processor as described herein.

BRIEF DESCRIPTION OF THE DRAWINGS

FIG. 1A shows a patient and a monitoring system comprising an adherent device, according to embodiments of the present invention;

FIG. 1B shows a bottom view of the adherent device as in FIG. 1A comprising an adherent patch;

FIG. 1C shows a top view of the adherent patch, as in FIG. 1B;

FIG. 1D shows a printed circuit board and electronic components over the adherent patch, as in FIG. 1C;

FIG. 1D1 shows an equivalent circuit that can be used to determine optimal frequencies for determining patient hydration, according to embodiments of the present invention;

FIG. 1D2 shows adherent devices as in FIGS. 1A-1D positioned on a patient to determine orientation of the adherent patch on the patient, according to embodiments of the present invention;

FIG. 1D3 shows vectors from a 3D accelerometer to determine orientation of the measurement axis of the patch adhered on the patient, according to embodiments of the present invention;

FIG. 1E shows batteries positioned over the printed circuit board and electronic components as in FIG. 1D;

FIG. 1F shows a top view of an electronics housing and a breathable cover over the batteries, electronic components and printed circuit board as in FIG. 1E;

FIG. 1G shows a side view of the adherent device as in FIGS. 1A to 1F;

FIG. 1H shown a bottom isometric view of the adherent device as in FIGS. 1A to 1G;

FIGS. 1I and 1J show a side cross-sectional view and an exploded view, respectively, of the adherent device as in FIGS. 1A to 1H;

FIGS. 1II and 1JI show a side cross-sectional view and an exploded view, respectively, of embodiments of the adherent device with a temperature sensor affixed to the gel cover;

FIG. 1K shows at least one electrode configured to electrically couple to a skin of the patient through a breathable tape, according to embodiments of the present invention;

FIG. 2 shows a method of monitoring a person, in accordance with embodiments of the present invention;

FIGS. 3A1 to 3A5 show heart rate, activity index, body posture, impedance, and respiration rate measured from an adherent device adhered to the skin of the patient;

FIG. 3B shows measured patient heart rate profile data in accordance with embodiments of the present invention;

FIG. 3C shows average maximum activity of patients based on age for ages from about 20 to about 90;

FIG. 3D1 shows correlation of heart rate with activity for patients without functional CI; and

FIG. 3D2 shows correlation of heart rate with activity for patients with functional CI.

DETAILED DESCRIPTION OF THE INVENTION

Embodiments comprise an adherent wireless communication apparatus and methods to measure patient data and determine the presence of functional chronotropic incompetence (CI). The patient measurement device may comprise one or

more of an adherent device or an implantable device, and processor system can determine CI with heart rate and activity data collected from the patient under conditions of daily living, for example when the patient is home.

As used herein, chronotropic incompetence encompasses a failure of the heart rate to elevate sufficiently when the patient is active. For example, although CI may comprise a failure of the heart rate to elevate to a percentage amount of 85% of the age predicted maximum heart rate during exercise, this amount can change based on pharmacological modification of heart rate response. Therefore, the determination of the CI of the patient can change based on treatment of the patient with pharmacologic compositions, and the determination of the CI of the patient can be based on patient treatment with medication in additional to measure physiological patient data as described herein.

As used herein functional CI encompasses a CI condition where the patient's heart rate fails to accommodate the patient's activities of daily living, resulting in debilitation under sub-maximum activity levels and heart rates.

The adherent device and processor system are capable of monitoring and tracking patient activity and heart rate (hereinafter "HR") so as to assess CI in a natural living environment outside the clinic, such as at home. The adherent device can also measure and compute respiratory rate and patient activity, such that correspondence among CI, respiration and activity can be determined. For example one or more processors may comprise instructions of a computer program so as to correlate the impact of CI to changes in other physiological parameters and patient symptoms. This combination of patient data can improve determination of the CI and correlate the CI to patient symptoms. For example the level of debilitation that CI is causing can be correlated to patient symptoms.

The adherent device and processor system can measure patient heart rate data and determine a maximum heart rate of the patient that can be used to monitor the patient. For example, the maximum heart rate of the patient may be determined without a cardiac stress test, and with patient heart rate data that is less than the actual maximum heart rate of the patient, such that the maximum heart rate can be determined safely when the patient is remote from a clinic. For example, an estimated maximum heart rate of the patient can be determined based on a patient a histogram distribution of the heart rate. Alternatively or in combination, the measured heart rate data can be adjusted based on one or more of patient activity and patient respiration.

The determined maximum heart rate of the patient can be combined in many ways with patient data to monitor the patient and trigger alerts when the patient is at risk, for example. The adherent device and processor system can determine the age predicted maximum heart rate, the age predicted heart rate reserve, the percent heart rate reserve. For example the adherent device and processor system can be configured to determine the age predicted maximum heart rate (APMHR) based on the patient age (hereinafter "AGE") with the formula:

$$\text{APMHR}=220-\text{AGE}.$$

The APMHR can be combined with the determined maximum heart rate of the patient to determine the CI of the patient. For example, the ratio of the maximum heart rate to the APMHR and corresponding percentage can be determined. When the maximum HR of the patient corresponds to less than about 85% of the APMHR, the patient be identified as having CI.

The adherent device and processor system can determine the age predicted heart rate reserve (hereinafter "APHRR") with the formula

$$\text{APHRR}=\text{APMHR}-\text{resting HR}.$$

The adherent device and processor system can determine the percent heart rate reserve (hereinafter "% HRR") with the formula

$$\% \text{ HRR}=[(\text{maximum HR})-(\text{Resting HR})]*100/\text{APHRR}.$$

The adherent device and processor system can determine histograms for each of the HR, the RR interval and the activity, and determine the correlation between these measurement data and derive indices from each of these measurement data.

In the many embodiments, the adherent device can communicate wirelessly so as to transmit the multi-sensor data to a server located remote from the patient. The adherent device can communicate to the server with a wireless communication gateway. The wireless communication gateway can receive data from the adherent device with wireless communication, for example Bluetooth™, and the gateway can transmit the data to the server with wireless communication, for example a cellular communication protocol.

The remote server may comprise a computer program having instructions embodied in a tangible memory medium so as to instruct the processor to combine the collected data from the device as well as demographic and medication information resident on the server, in order to determine the presence of patient CI. The instructions of the program can also calculate the CI parameters and raise an alert if a adverse condition is detected. Alternatively or in combination, the gateway near the patient may comprise a processor having a tangible memory medium, and the gateway may comprise instructions of a computer program embodied on the tangible medium, so as to instruct the gateway processor to combine the collected data from the adherent device as well as the demographic and the medication information.

In many embodiments, the adherent device may comprise a processor and perform real-time diagnostic assessment of CI and alert the patient and/or care provider via audio and/or visual cues based on standard CI classification cut-off levels. This is possible with an adherent device that can store the theoretical age predicted maximum heart rate (hereinafter "APMHR") and then track patient activity and heart rate so as to assess CI in real time. Alternatively or in combination, the adherent device can retrieve patient data related to the APMHR from the server, for example the patient's age when the patient has used the adherent device before and the patient data is stored on a database of the server. This retrieval of the APMHR data can improve the accuracy of the device as used and prevent errors, as the patient age, for example, can be stored in the data base such that the physician or patient from entering the age manually and may also avoid data entry errors.

Alternatively or in combination, the adherent device may store the CI assessment data for future offline data download, or transmit the data in real-time directly or indirectly (through an intermediary device that is paired to the adherent device) to a data storage entity.

The systems, methods and apparatus as described herein may comprise instructions of a processor system so as to determine functional CI based on an analysis of the envelop of HR histogram profile and the profile of HR change with activity so as to assess cardio-acceleration and cardio-blunting.

There may be additional embodiments and implementations for this method and apparatus based on the teachings described herein that will be apparent to a person of ordinary skill in the art.

FIG. 1A shows a patient P and a monitoring system 10. Patient P comprises a midline M, a first side S1, for example a right side, and a second side S2, for example a left side. Monitoring system 10 comprises an adherent device 100. Adherent device 100 can be adhered to a patient P at many locations, for example thorax T of patient P. In many embodiments, the adherent device may adhere to one side of the patient, from which side data can be collected. Work in relation with embodiments of the present invention suggests that location on a side of the patient can provide comfort for the patient while the device is adhered to the patient. The monitoring system 10 and adherent device 100 may comprise components as described in U.S. Pub. No. US-2009-0076345-A1, entitled "Adherent Device with Multiple Physiological Sensors", the full disclosure of which is incorporated herein by reference and suitable for combination in accordance with some embodiments of the present invention as described herein.

Monitoring system 10 includes components to transmit data to a remote center 106. Remote center 106 can be located in a different building from the patient, for example in the same town as the patient, and can be located as far from the patient as a separate continent from the patient, for example the patient located on a first continent and the remote center located on a second continent. Adherent device 100 can communicate wirelessly to an intermediate device 102, for example with a single wireless hop from the adherent device on the patient to the intermediate device. Intermediate device 102 can communicate with remote center 106 in many ways, for example with an Internet connection and/or with a cellular connection. In many embodiments, monitoring system 10 comprises a distributed processor system with at least one processor comprising a tangible medium of device 100, at least one processor 102P of intermediate device 102, and at least one processor 106P at remote center 106, each of which processors can be in electronic communication with the other processors. At least one processor 102P comprises a tangible medium 102T, and at least one processor 106P comprises a tangible medium 106T. Remote processor 106P may comprise a backend server located at the remote center. Remote center 106 can be in communication with a health care provider 108A with a communication system 107A, such as the Internet, an intranet, phone lines, wireless and/or satellite phone. Health care provider 108A, for example a family member, can be in communication with patient P with a communication, for example with a two way communication system, as indicated by arrow 109A, for example by cell phone, email, or landline. Remote center 106 can be in communication with a health care professional, for example a physician 108B, with a communication system 107B, such as the Internet, an intranet, phone lines, wireless and/or satellite phone. Physician 108B can be in communication with patient P with a communication, for example with a two way communication system, as indicated by arrow 109B, for example by cell phone, email, landline. Remote center 106 can be in communication with an emergency responder 108C, for example a 911 operator and/or paramedic, with a communication system 107C, such as the Internet, an intranet, phone lines, wireless and/or satellite phone. Emergency responder 108C can travel to the patient as indicated by arrow 109C. Thus, in many embodiments, monitoring system 10 comprises a closed loop system in which patient care can be

monitored and implemented from the remote center in response to signals from the adherent device.

In many embodiments, the adherent device may continuously monitor physiological parameters, communicate wirelessly with a remote center, and provide alerts when necessary. The system may comprise an adherent patch, which attaches to the patient's thorax and contains sensing electrodes, battery, memory, logic, and wireless communication capabilities. In some embodiments, the patch can communicate with the remote center, via the intermediate device in the patient's home. In some embodiments, remote center 106 receives the patient data and applies a patient evaluation algorithm, for example the prediction algorithm to predict patient physiological or mental deterioration. In some embodiments, the algorithm may comprise an algorithm to predict impending patient physiological or mental deterioration, for example based on decreased hydration and activity. When a flag is raised, the center may communicate with the patient, hospital, nurse, and/or physician to allow for therapeutic intervention, for example to prevent further physiological or mental deterioration.

The adherent device may be affixed and/or adhered to the body in many ways. For example, with at least one of the following an adhesive tape, a constant-force spring, suspenders around shoulders, a screw-in microneedle electrode, a pre-shaped electronics module to shape fabric to a thorax, a pinch onto roll of skin, or transcutaneous anchoring. Patch and/or device replacement may occur with a keyed patch (e.g. two-part patch), an outline or anatomical mark, a low-adhesive guide (place guide/remove old patch/place new patch/remove guide), or a keyed attachment for chatter reduction. The patch and/or device may comprise an adhesiveless embodiment (e.g. chest strap), and/or a low-irritation adhesive for sensitive skin. The adherent patch and/or device can comprise many shapes, for example at least one of a dogbone, an hourglass, an oblong, a circular or an oval shape.

In many embodiments, the adherent device may comprise a reusable electronics module with replaceable patches, and each of the replaceable patches may include a battery. The module may collect cumulative data for approximately 90 days and/or the entire adherent component (electronics+patch) may be disposable. In a completely disposable embodiment, a "baton" mechanism may be used for data transfer and retention, for example baton transfer may include baseline information. In some embodiments, the device may have a rechargeable module, and may use dual battery and/or electronics modules, wherein one module 101A can be recharged using a charging station 103 while the other module 101B is placed on the adherent patch with connectors. In some embodiments, the intermediate device 102 may comprise the charging module, data transfer, storage and/or transmission, such that one of the electronics modules can be placed in the intermediate device for charging and/or data transfer while the other electronics module is worn by the patient.

System 10 can perform the following functions: initiation, programming, measuring, storing, analyzing, communicating, predicting, and displaying. The adherent device may contain a subset of the following physiological sensors: bio-impedance, respiration, respiration rate variability, heart rate (ave, min, max), heart rhythm, heart rate variability (HRV), heart rate turbulence (HRT), heart sounds (e.g. S3), respiratory sounds, blood pressure, activity, posture, wake/sleep, orthopnea, temperature/heat flux, and weight. The activity sensor may comprise one or more of the following: ball switch, accelerometer, minute ventilation, HR, bioimpedance noise, skin temperature/heat flux, BP, muscle noise, posture.

The adherent device can wirelessly communicate with remote center 106. The communication may occur directly (via a cellular or Wi-Fi network), or indirectly through intermediate device 102. Intermediate device 102 may consist of multiple devices, which can communicate wired or wirelessly to relay data to remote center 106.

In many embodiments, instructions are transmitted from remote site 106 to a processor supported with the adherent patch on the patient, and the processor supported with the patient can receive updated instructions for the patient treatment and/or monitoring, for example while worn by the patient.

FIG. 1B shows a bottom view of adherent device 100 as in FIG. 1A comprising an adherent patch 110. Adherent patch 110 comprises a first side, or a lower side 110A, that is oriented toward the skin of the patient when placed on the patient. In many embodiments, adherent patch 110 comprises a tape 110T which is a material, preferably breathable, with an adhesive 116A. Patient side 110A comprises adhesive 116A to adhere the patch 110 and adherent device 100 to patient P. Electrodes 112A, 112B, 112C and 112D are affixed to adherent patch 110. In many embodiments, at least four electrodes are attached to the patch, for example six electrodes. In some embodiments the patch comprises two electrodes, for example two electrodes to measure the electrocardiogram (ECG) of the patient. Gel 114A, gel 114B, gel 114C and gel 114D can each be positioned over electrodes 112A, 112B, 112C and 112D, respectively, to provide electrical conductivity between the electrodes and the skin of the patient. In many embodiments, the electrodes can be affixed to the patch 110, for example with known methods and structures such as rivets, adhesive, stitches, etc. In many embodiments, patch 110 comprises a breathable material to permit air and/or vapor to flow to and from the surface of the skin.

FIG. 1C shows a top view of the adherent patch 100, as in FIG. 1B. Adherent patch 100 comprises a second side, or upper side 110B. In many embodiments, electrodes 112A, 112B, 112C and 112D extend from lower side 110A through adherent patch 110 to upper side 110B. An adhesive 116B can be applied to upper side 110B to adhere structures, for example a breathable cover, to the patch such that the patch can support the electronics and other structures when the patch is adhered to the patient. The PCB may comprise completely flex PCB, rigid PCB, rigid PCB combined flex PCB and/or rigid PCB boards connected by cable.

FIG. 1D shows a printed circuit boards and electronic components over adherent patch 110, as in FIGS. 1A to 1C. In some embodiments, a printed circuit board (PCB), for example flex printed circuit board 120, may be connected to electrodes 112A, 112B, 112C and 112D with connectors 122A, 122B, 122C and 122D. Flex printed circuit board 120 can include traces 123A, 123B, 123C and 123D that extend to connectors 122A, 122B, 122C and 122D, respectively, on the flex PCB. Connectors 122A, 122B, 122C and 122D can be positioned on flex printed circuit board 120 in alignment with electrodes 112A, 112B, 112C and 112D so as to electrically couple the flex PCB with the electrodes. In some embodiments, connectors 122A, 122B, 122C and 122D may comprise insulated wires and/or a film with conductive ink that provide strain relief between the PCB and the electrodes. For example, connectors 122A, 122B, 122C and 122D may comprise a flexible film, such as at least one of known polyester film or known polyurethane film coated with a conductive ink, for example a conductive silver ink. Examples of structures to provide strain relief are also described in U.S. patent application Ser. No. 12/209,288, entitled "Adherent Device with Multiple Physiological Sensors", filed on Sep. 12, 2008. In

some embodiments, additional PCB's, for example rigid PCB's 120A, 120B, 120C and 120D, can be connected to flex printed circuit board 120. Electronic components 130 can be connected to flex printed circuit board 120 and/or mounted thereon. In some embodiments, electronic components 130 can be mounted on the additional PCB's.

Electronic components 130 comprise components to take physiologic measurements, transmit data to remote center 106 and receive commands from remote center 106. In many embodiments, electronics components 130 may comprise known low power circuitry, for example complementary metal oxide semiconductor (CMOS) circuitry components. Electronics components 130 comprise an activity sensor and activity circuitry 134, impedance circuitry 136 and electrocardiogram circuitry, for example ECG circuitry 136. In some embodiments, electronics circuitry 130 may comprise a microphone and microphone circuitry 142 to detect an audio signal from within the patient, and the audio signal may comprise a heart sound and/or a respiratory sound, for example an S3 heart sound and a respiratory sound with rales and/or crackles.

Electronics circuitry 130 may comprise a temperature sensor, for example a thermistor in contact with the skin of the patient, and temperature sensor circuitry 144 to measure a temperature of the patient, for example a temperature of the skin of the patient. A temperature sensor may be used to determine the sleep and wake state of the patient. The temperature of the patient can decrease as the patient goes to sleep and increase when the patient wakes up.

Work in relation to embodiments of the present invention suggests that skin temperature may effect impedance and/or hydration measurements, and that skin temperature measurements may be used to correct impedance and/or hydration measurements. In some embodiments, increase in skin temperature or heat flux can be associated with increased vasodilation near the skin surface, such that measured impedance measurement decreased, even through the hydration of the patient in deeper tissues under the skin remains substantially unchanged. Thus, use of the temperature sensor can allow for correction of the hydration signals to more accurately assess the hydration, for example extra cellular hydration, of deeper tissues of the patient, for example deeper tissues in the thorax.

Electronics circuitry 130 may comprise a processor 146. Processor 146 comprises a tangible medium, for example read only memory (ROM), electrically erasable programmable read only memory (EEPROM) and/or random access memory (RAM). Electronic circuitry 130 may comprise real time clock and frequency generator circuitry 148. In some embodiments, processor 136 may comprise the frequency generator and real time clock. The processor can be configured to control a collection and transmission of data from the impedance circuitry electrocardiogram circuitry and the accelerometer. In many embodiments, device 100 comprises a distributed processor system, for example with multiple processors on device 100.

In many embodiments, electronics components 130 comprise wireless communications circuitry 132 to communicate with remote center 106. Printed circuit board 120 may comprise an antenna to facilitate wireless communication. The antenna may be integral with printed circuit board 120 or may be separately coupled thereto. The wireless communication circuitry can be coupled to the impedance circuitry, the electrocardiogram circuitry and the accelerometer to transmit to a remote center with a communication protocol at least one of the hydration signal, the electrocardiogram signal or the inclination signal. In specific embodiments, wireless communication circuitry is configured to transmit the hydration signal,

the electrocardiogram signal and the inclination signal to the remote center with a single wireless hop, for example from wireless communication circuitry **132** to intermediate device **102**. The communication protocol comprises at least one of Bluetooth, ZigBee, WiFi, WiMAX, IR, amplitude modulation or frequency modulation. In many embodiments, the communications protocol comprises a two way protocol such that the remote center is capable of issuing commands to control data collection.

Intermediate device **102** may comprise a data collection system to collect and store data from the wireless transmitter. The data collection system can be configured to communicate periodically with the remote center. The data collection system can transmit data in response to commands from remote center **106** and/or in response to commands from the adherent device.

Activity sensor and activity circuitry **134** can comprise many known activity sensors and circuitry. In many embodiments, the accelerometer comprises at least one of a piezoelectric accelerometer, capacitive accelerometer or electro-mechanical accelerometer. The accelerometer may comprise a 3-axis accelerometer to measure at least one of an inclination, a position, an orientation or acceleration of the patient in three dimensions. Work in relation to embodiments of the present invention suggests that three dimensional orientation of the patient and associated positions, for example sitting, standing, lying down, can be very useful when combined with data from other sensors, for example ECG data and/or hydration data.

Impedance circuitry **136** can generate both hydration data and respiration data. In many embodiments, impedance circuitry **136** is electrically connected to electrodes **112A**, **112B**, **112C** and **112D** in a four pole configuration, such that electrodes **112A** and **112D** comprise outer electrodes that are driven with a current and comprise force electrodes that force the current through the tissue. The current delivered between electrodes **112A** and **112D** generates a measurable voltage between electrodes **112B** and **112C**, such that electrodes **112B** and **112C** comprise inner, sense, electrodes that sense and/or measure the voltage in response to the current from the force electrodes. In some embodiments, electrodes **112B** and **112C** may comprise force electrodes and electrodes **112A** and **112D** may comprise sense electrodes. The voltage measured by the sense electrodes can be used to measure the impedance of the patient and determine the respiration rate and/or hydration of the patient. The electrocardiogram circuitry may be coupled to the sense electrodes to measure the electrocardiogram signal, for example as described in U.S. patent application Ser. No. 12/209,288, entitled "Adherent Device with Multiple Physiological Sensors", filed on Sep. 12, 2008.

FIG. 1D1 shows an equivalent circuit **152** that can be used to determine optimal frequencies for measuring patient hydration. Work in relation to embodiments of the present invention indicates that the frequency of the current and/or voltage at the force electrodes can be selected so as to provide impedance signals related to the extracellular and/or intracellular hydration of the patient tissue. Equivalent circuit **152** comprises an intracellular resistance **156**, or $R(ICW)$ in series with a capacitor **154**, and an extracellular resistance **158**, or $R(ECW)$. Extracellular resistance **158** is in parallel with intracellular resistance **156** and capacitor **154** related to capacitance of cell membranes. In many embodiments, impedances can be measured and provide useful information over a wide range of frequencies, for example from about 0.5 kHz to about 200 KHz. Work in relation to embodiments of the present invention suggests that extracellular resistance **158**

can be significantly related extracellular fluid and to patient physiological or mental physiological or mental deterioration, and that extracellular resistance **158** and extracellular fluid can be effectively measured with frequencies in a range from about 0.5 kHz to about 20 kHz, for example from about 1 kHz to about 10 kHz. In some embodiments, a single frequency can be used to determine the extracellular resistance and/or fluid. As sample frequencies increase from about 10 kHz to about 20 kHz, capacitance related to cell membranes decrease the impedance, such that the intracellular fluid contributes to the impedance and/or hydration measurements. Thus, many embodiments of the present invention measure hydration with frequencies from about 0.5 kHz to about 20 kHz to determine patient hydration.

In many embodiments, impedance circuitry **136** can be configured to determine respiration of the patient. In specific embodiments, the impedance circuitry can measure the hydration at 25 Hz intervals, for example at 25 Hz intervals using impedance measurements with a frequency from about 0.5 kHz to about 20 kHz.

ECG circuitry **138** can generate electrocardiogram signals and data from two or more of electrodes **112A**, **112B**, **112C** and **112D** in many ways. In some embodiments, ECG circuitry **138** is connected to inner electrodes **112B** and **112C**, which may comprise sense electrodes of the impedance circuitry as described above. In some embodiments, ECG circuitry **138** can be connected to electrodes **112A** and **112D** so as to increase spacing of the electrodes. The inner electrodes may be positioned near the outer electrodes to increase the voltage of the ECG signal measured by ECG circuitry **138**. In many embodiments, the ECG circuitry may measure the ECG signal from electrodes **112A** and **112D** when current is not passed through electrodes **112A** and **112D**, for example with switches as described in U.S. application Ser. No. 60/972,527, the full disclosure of which has been previously incorporated herein by reference.

FIG. 1D2 shows an adherent device, for example adherent device **100**, positioned on patient P to determine orientation of the adherent patch. X-axis **112X** of device **100** is inclined at an angle α to horizontal axis P_x of patient P. Z-axis **112Z** of device **100** is inclined at angle α to vertical axis P_z of patient P. Y-axis **112Y** may be inclined at a second angle, for example α , to anterior posterior axis P_y and vertical axis P_z . As the accelerometer of adherent device **100** can be sensitive to gravity, inclination of the patch relative to axis of the patient can be measured, for example when the patient stands.

ECG circuitry **138** can be coupled to the electrodes in many ways to define an electrocardiogram vector. For example electrode **112A** can be coupled to a positive amplifier terminal of ECG circuitry **138** and electrode **112D** can be coupled to a negative amplifier terminal of ECG circuitry **138** to define an orientation of an electrocardiogram vector along the electrode measurement axis. To define an electrocardiogram vector with an opposite orientation electrode **112D** can be coupled to the positive amplifier terminal of ECG circuitry **138** and electrode **112A** can be coupled to the negative amplifier terminal of ECG circuitry **138**. The ECG circuitry may be coupled to the inner electrodes so as to define an ECG vector along a measurement axis of the inner electrodes.

FIG. 1D3 shows vectors from a 3D accelerometer to determine orientation of the measurement axis of the patch adhered on the patient. The orientation can be determined for each patch adhered to the patient. A Z-axis vector **112ZV** can be measured along vertical axis **112Z** with an accelerometer signal from axis **134Z** of accelerometer **134A**. An X-axis vector **112XV** can be measured along horizontal axis **112X** with an accelerometer signal from axis **134X** of accelerom-

eter **134A**. Inclusion angle α can be determined in response to X-axis vector **112XV** and Z-axis vector **112ZV**, for example with vector addition of X-axis vector **112XV** and Z-axis vector **112ZV**. An inclusion angle α for the patch along the Y and Z axes can be similarly obtained an accelerometer signal from axis **134Y** of accelerometer **134A** and vector **112ZV**.

FIG. **1E** shows batteries **150** positioned over the flex printed circuit board and electronic components as in FIG. **1D**. Batteries **150** may comprise rechargeable batteries that can be removed and/or recharged. In some embodiments, batteries **150** can be removed from the adherent patch and recharged and/or replaced.

FIG. **1F** shows a top view of a cover **162** over the batteries, electronic components and flex printed circuit board as in FIGS. **1A** to **1E**. In many embodiments, an electronics housing **160** may be disposed under cover **162** to protect the electronic components, and in some embodiments electronics housing **160** may comprise an encapsulant over the electronic components and PCB. In some embodiments, cover **162** can be adhered to adherent patch **110** with an adhesive **164** on an underside of cover **162**. In many embodiments, electronics housing **160** may comprise a water proof material, for example a sealant adhesive such as epoxy or silicone coated over the electronics components and/or PCB. In some embodiments, electronics housing **160** may comprise metal and/or plastic. Metal or plastic may be potted with a material such as epoxy or silicone.

Cover **162** may comprise many known biocompatible cover, casing and/or housing materials, such as elastomers, for example silicone. The elastomer may be fenestrated to improve breathability. In some embodiments, cover **162** may comprise many known breathable materials, for example polyester, polyamide, nylon and/or elastane (Spandex™). The breathable fabric may be coated to make it water resistant, waterproof, and/or to aid in wicking moisture away from the patch.

FIG. **1G** shows a side view of adherent device **100** as in FIGS. **1A** to **1F**. Adherent device **100** comprises a maximum dimension, for example a length **170** from about 4 to 10 inches (from about 100 mm to about 250 mm), for example from about 6 to 8 inches (from about 150 mm to about 200 mm). In some embodiments, length **170** may be no more than about 6 inches (no more than about 150 mm). Adherent device **100** comprises a thickness **172**. Thickness **172** may comprise a maximum thickness along a profile of the device. Thickness **172** can be from about 0.2 inches to about 0.6 inches (from about 5 mm to about 15 mm), from about 0.2 inches to about 0.4 inches (from about 5 mm to about 10 mm), for example about 0.3 inches (about 7.5 mm).

FIG. **1H** shown a bottom isometric view of adherent device **100** as in FIGS. **1A** to **1G**. Adherent device **100** comprises a width **174**, for example a maximum width along a width profile of adherent device **100**. Width **174** can be from about 2 to about 4 inches (from about 50 mm to 100 mm), for example about 3 inches (about 75 mm).

FIGS. **1I** and **1J** show a side cross-sectional view and an exploded view, respectively, of adherent device **100** as in FIGS. **1A** to **1H**. Device **100** comprises several layers. Gel **114A**, or gel layer, is positioned on electrode **112A** to provide electrical conductivity between the electrode and the skin. Electrode **112A** may comprise an electrode layer. Adherent patch **110** may comprise a layer of breathable tape **110T**, for example a known breathable tape, such as tricot-knit polyester fabric. An adhesive **116A**, for example a layer of acrylate pressure sensitive adhesive, can be disposed on underside **110A** of adherent patch **110**.

FIGS. **1I** and **1J** show a side cross-sectional view and an exploded view, respectively, of embodiments of the adherent device with a temperature sensor affixed to the gel cover. In these embodiments, gel cover **180** extends over a wider area than in the embodiments shown in FIGS. **1I** and **1J**. Temperature sensor **177** is disposed over a peripheral portion of gel cover **180**. Temperature sensor **177** can be affixed to gel cover **180** such that the temperature sensor can move when the gel cover stretches and tape stretch with the skin of the patient. Temperature sensor **177** may be coupled to temperature sensor circuitry **144** through a flex connection comprising at least one of wires, shielded wires, non-shielded wires, a flex circuit, or a flex PCB. This coupling of the temperature sensor allows the temperature near the skin to be measured through the breathable tape and the gel cover. The temperature sensor can be affixed to the breathable tape, for example through a cutout in the gel cover with the temperature sensor positioned away from the gel pads. A heat flux sensor can be positioned near the temperature sensor, for example to measure heat flux through to the gel cover, and the heat flux sensor coupled to heat flux circuitry similar to the temperature sensor.

The adherent device comprises electrodes **112A1**, **112B1**, **112C1** and **112D1** configured to couple to tissue through apertures in the breathable tape **110T**. Electrodes **112A1**, **112B1**, **112C1** and **112D1** can be fabricated in many ways. For example, electrodes **112A1**, **112B1**, **112C1** and **112D1** can be printed on a flexible connector **112F**, such as silver ink on polyurethane. Breathable tape **110T** comprise apertures **180A1**, **180B1**, **180C1** and **180D1**. Electrodes **112A1**, **112B1**, **112C1** and **112D1** are exposed to the gel through apertures **180A1**, **180B1**, **180C1** and **180D1** of breathable tape **110T**. Gel **114A**, gel **114B**, gel **114C** and gel **114D** can be positioned over electrodes **112A1**, **112B1**, **112C1** and **112D1** and the respective portions of breathable tape **110T** proximate apertures **180A1**, **180B1**, **180C1** and **180D1**, so as to couple electrodes **112A1**, **112B1**, **112C1** and **112D1** to the skin of the patient. The flexible connector **112F** comprising the electrodes can extend from under the gel cover to the printed circuit board to connect to the printed circuit boards and/or components supported thereon. For example, flexible connector **112F** may comprise flexible connector **122A** to provide strain relief, as described above.

In many embodiments, gel **114A**, or gel layer, comprises a hydrogel that is positioned on electrode **112A** to provide electrical conductivity between the electrode and the skin. In many embodiments, gel **114A** comprises a hydrogel that provides a conductive interface between skin and electrode, so as to reduce impedance between electrode/skin interface. In many embodiments, gel may comprise water, glycerol, and electrolytes, pharmacological agents, such as beta blockers, ace inhibitors, diuretics, steroid for inflammation, antibiotic, antifungal agent. In specific embodiments the gel may comprise cortisone steroid. The gel layer may comprise many shapes, for example, square, circular, oblong, star shaped, many any polygon shapes. In specific embodiments, the gel layer may comprise at least one of a square or circular geometry with a dimension in a range from about 0.005" to about 0.100", for example within a range from about 0.015"-0.070", in some embodiments within a range from about 0.015"-0.040", and in specific embodiments within a range from about 0.020"-0.040". In many embodiments, the gel layer of each electrode comprises an exposed surface area to contact the skin within a range from about 100 mm² to about 1500 mm², for example a range from about 250 mm² to about 750 mm², and in specific embodiments within a range from about 350 mm² to about 650 mm². Work in relation with embodiments of the present invention suggests that such

dimensions and/or exposed surface areas can provide enough gel area for robust skin interface without excessive skin coverage. In many embodiments, the gel may comprise an adhesion to skin, as may be tested with a 180 degree peel test on stainless steel, of at least about 3 oz/in, for example an adhesion within a range from about 5-10 oz/in. In many embodiments, a spacing between gels is at least about 5 mm, for example at least about 10 mm. Work in relation to embodiments of the present invention suggests that this spacing may inhibit the gels from running together so as to avoid crosstalk between the electrodes. In many embodiments, the gels comprise a water content within a range from about 20% to about 30%, a volume resistivity within a range from about 500 to 2000 ohm-cm, and a pH within a range from about 3 to about 5.

In many embodiments, the electrodes, for example electrodes 112A to 112D, may comprise an electrode layer. A 0.001"-0.005" polyester strip with silver ink for traces can extend to silver/silver chloride electrode pads. In many embodiments, the electrodes can provide electrical conduction through hydrogel to skin, and in some embodiments may be coupled directly to the skin. Although at least 4 electrodes are shown, some embodiments comprise at least two electrodes, for example 2 electrodes. In some embodiments, the electrodes may comprise at least one of carbon-filled ABS plastic, silver, nickel, or electrically conductive acrylic tape. In specific embodiments, the electrodes may comprise at least one of carbon-filled ABS plastic, Ag/AgCl. The electrodes may comprise many geometric shapes to contact the skin, for example at least one of square, circular, oblong, star shaped, polygon shaped, or round. In specific embodiments, a dimension across a width of each electrodes is within a range from about 0.002" to about 0.050", for example from about 0.010 to about 0.040". In many a surface area of the electrode toward the skin of the patient is within a range from about 25 mm² to about 1500 mm², for example from about 75 mm² to about 150 mm². In many embodiments, the electrode comprises a tape that may cover the gel near the skin of the patient. In specific embodiments, the two inside electrodes may comprise force, or current electrodes, with a center to center spacing within a range from about 20 to about 50 mm. In specific embodiments, the two outside electrodes may comprise measurement electrodes, for example voltage electrodes, and a center-center spacing between adjacent voltage and current electrodes is within a range from about 15 mm to about 35 mm. Therefore, in many embodiments, a spacing between inner electrodes may be greater than a spacing between an inner electrode and an outer electrode.

In many embodiments, adherent patch 110 may comprise a layer of breathable tape 110T, for example a known breathable tape, such as tricot-knit polyester fabric. In many embodiments, breathable tape 110T comprises a backing material, or backing 111, with an adhesive. In many embodiments, the patch adheres to the skin of the patient's body, and comprises a breathable material to allow moisture vapor and air to circulate to and from the skin of the patient through the tape. In many embodiments, the backing is conformable and/or flexible, such that the device and/or patch does not become detached with body movement. In many embodiments, backing can sufficiently regulate gel moisture in absence of gel cover. In many embodiments, adhesive patch may comprise from 1 to 2 pieces, for example 1 piece. In many embodiments, adherent patch 110 comprises pharmacological agents, such as at least one of beta blockers, ace inhibitors, diuretics, steroid for inflammation, antibiotic, or antifungal agent. In specific embodiments, patch 110 comprises cortisone steroid. Patch 110 may comprise many geometric

shapes, for example at least one of oblong, oval, butterfly, dogbone, dumbbell, round, square with rounded corners, rectangular with rounded corners, or a polygon with rounded corners. In specific embodiments, a geometric shape of patch 110 comprises at least one of an oblong, an oval or round. In many embodiments, the geometric shape of the patch comprises a radius on each corner that is no less than about one half a width and/or diameter of tape. Work in relation to embodiments of the present invention suggests that rounding the corner can improve adherence of the patch to the skin for an extended period of time because sharp corners, for example right angle corners, can be easy to peel. In specific embodiments, a thickness of adherent patch 110 is within a range from about 0.001" to about 0.020", for example within a range from about 0.005" to about 0.010". Work in relation to embodiments of the present invention indicates that these ranges of patch thickness can improve adhesion of the device to the skin of the patient for extended periods as a thicker adhesive patch, for example tape, may peel more readily. In many embodiments, length 170 of the patch is within a range from about 2" to about 10", width 174 of the patch is within a range from about 1" to about 5". In specific embodiments, length 170 is within a range from about 4" to about 8" and width 174 is within a range from about 2" to about 4". In many embodiments, an adhesion to the skin, as measured with a 180 degree peel test on stainless steel, can be within a range from about 10 to about 100 oz/in width, for example within a range from about 30 to about 70 oz/in width. Work in relation to embodiments of the present invention suggests that adhesion within these ranges may improve the measurement capabilities of the patch because if the adhesion is too low, patch will not adhere to the skin of the patient for a sufficient period of time and if the adhesion is too high, the patch may cause skin irritation upon removal. In many embodiments adherent patch 110 comprises a moisture vapor transmission rate (MVTR, g/m²/24 hrs) per American Standard for Testing and Materials E-96 (ASTM E-96) is at least about 400, for example at least about 1000. Work in relation to embodiments of the present invention suggest that MVTR values as specified above can provide improved comfort, for example such that in many embodiments skin does not itch. In some embodiments, the breathable tape 110T of adherent patch 110 may comprise a porosity (sec./100 cc/in²) within a wide range of values, for example within a range from about 0 to about 200. The porosity of breathable tape 110T may be within a range from about 0 to about 5. The above amounts of porosity can minimize itching of the patient's skin when the patch is positioned on the skin of the patient. In many embodiments, the MVTR values above may correspond to a MVTR through both the gel cover and the breathable tape. The above MVTR values may also correspond to an MVTR through the breathable tape, the gel cover and the breathable cover. The MVTR can be selected to minimize patient discomfort, for example itching of the patient's skin.

In some embodiments, the breathable tape may contain and elute a pharmaceutical agent, such as an antibiotic, anti-inflammatory or antifungal agent, when the adherent device is placed on the patient.

In many embodiments, tape 110T of adherent patch 110 may comprise backing material, or backing 111, such as a fabric configured to provide properties of patch 110 as described above. In many embodiments backing 111 provides structure to breathable tape 110T, and many functional properties of breathable tape 110T as described above. In many embodiments, backing 111 comprises at least one of polyester, polyurethane, rayon, nylon, breathable plastic film; woven, nonwoven, spun lace, knit, film, or foam. In specific

embodiments, backing **111** may comprise polyester tricot knit fabric. In many embodiments, backing **111** comprises a thickness within a range from about 0.0005" to about 0.020", for example within a range from about 0.005" to about 0.010".

In many embodiments, an adhesive **116A**, for example breathable tape adhesive comprising a layer of acrylate pressure sensitive adhesive, can be disposed on underside **110A** of patch **110**. In many embodiments, adhesive **116A** adheres adherent patch **110** comprising backing **111** to the skin of the patient, so as not to interfere with the functionality of breathable tape, for example water vapor transmission as described above. In many embodiments, adhesive **116A** comprises at least one of acrylate, silicone, synthetic rubber, synthetic resin, hydrocolloid adhesive, pressure sensitive adhesive (PSA), or acrylate pressure sensitive adhesive. In many embodiments, adhesive **116A** comprises a thickness from about 0.0005" to about 0.005", in specific embodiments no more than about 0.003". Work in relation to embodiments of the present invention suggests that these thicknesses can allow the tape to breathe and/or transmit moisture, so as to provide patient comfort.

A gel cover **180**, or gel cover layer, for example a polyurethane non-woven tape, can be positioned over patch **110** comprising the breathable tape. A PCB layer, for example flex printed circuit board **120**, or flex PCB layer, can be positioned over gel cover **180** with electronic components **130** connected and/or mounted to flex printed circuit board **120**, for example mounted on flex PCB so as to comprise an electronics layer disposed on the flex PCB layer. In many embodiments, the adherent device may comprise a segmented inner component, for example the PCB may be segmented to provide at least some flexibility. In many embodiments, the electronics layer may be encapsulated in electronics housing **160** which may comprise a waterproof material, for example silicone or epoxy. In many embodiments, the electrodes are connected to the PCB with a flex connection, for example trace **123A** of flex printed circuit board **120**, so as to provide strain relive between the electrodes **112A**, **112B**, **112C** and **112D** and the PCB.

Gel cover **180** can inhibit flow of gel **114A** and liquid. In many embodiments, gel cover **180** can inhibit gel **114A** from seeping through breathable tape **110T** to maintain gel integrity over time. Gel cover **180** can also keep external moisture from penetrating into gel **114A**. For example gel cover **180** can keep liquid water from penetrating through the gel cover into gel **114A**, while allowing moisture vapor from the gel, for example moisture vapor from the skin, to transmit through the gel cover. The gel cover may comprise a porosity at least 200 sec./100 cc/in², and this porosity can ensure that there is a certain amount of protection from external moisture for the hydrogel.

In many embodiments, the gel cover can regulate moisture of the gel near the electrodes so as to keeps excessive moisture, for example from a patient shower, from penetrating gels near the electrodes. In many embodiments, the gel cover may avoid release of excessive moisture form the gel, for example toward the electronics and/or PCB modules. Gel cover **180** may comprise at least one of a polyurethane, polyethylene, polyolefin, rayon, PVC, silicone, non-woven material, foam, or a film. In many embodiments gel cover **180** may comprise an adhesive, for example a acrylate pressure sensitive adhesive, to adhere the gel cover to adherent patch **110**. In specific embodiments gel cover **180** may comprise a polyurethane film with acrylate pressure sensitive adhesive. In many embodiments, a geometric shape of gel cover **180** comprises at least one of oblong, oval, butterfly, dogbone, dumbbell, round, square, rectangular with rounded corners, or polygo-

nal with rounded corners. In specific embodiments, a geometric shape of gel cover **180** comprises at least one of oblong, oval, or round. In many embodiments, a thickness of gel cover is within a range from about 0.0005" to about 0.020", for example within a range from about 0.0005 to about 0.010". In many embodiments, gel cover **180** can extend outward from about 0-20 mm from an edge of gels, for example from about 5-15 mm outward from an edge of the gels.

In many embodiments, the breathable tape of adherent patch **110** comprises a first mesh with a first porosity and gel cover **180** comprises a breathable tape with a second porosity, in which the second porosity is less than the first porosity to inhibit flow of the gel through the breathable tape.

In many embodiments, device **100** includes a printed circuitry, for example a printed circuitry board (PCB) module that includes at least one PCB with electronics component mounted thereon on and the battery, as described above. In many embodiments, the PCB module comprises two rigid PCB modules with associated components mounted therein, and the two rigid PCB modules are connected by flex circuit, for example a flex PCB. In specific embodiments, the PCB module comprises a known rigid FR4 type PCB and a flex PCB comprising known polyimide type PCB. In specific embodiments, the PCB module comprises a rigid PCB with flex interconnects to allow the device to flex with patient movement. The geometry of flex PCB module may comprise many shapes, for example at least one of oblong, oval, butterfly, dogbone, dumbbell, round, square, rectangular with rounded corners, or polygon with rounded corners. In specific embodiments the geometric shape of the flex PCB module comprises at least one of dogbone or dumbbell. The PCB module may comprise a PCB layer with flex PCB **120** can be positioned over gel cover **180** and electronic components **130** connected and/or mounted to flex PCB **120** so as to comprise an electronics layer disposed on the flex PCB. In many embodiments, the adherent device may comprise a segmented inner component, for example the PCB, for limited flexibility. The printed circuit may comprise polyester film with silver traces printed thereon.

In many embodiments, the electronics layer may be encapsulated in electronics housing **160**. Electronics housing **160** may comprise an encapsulant, such as a dip coating, which may comprise a waterproof material, for example silicone and/or epoxy. In many embodiments, the PCB encapsulant protects the PCB and/or electronic components from moisture and/or mechanical forces. The encapsulant may comprise silicone, epoxy, other adhesives and/or sealants. In some embodiments, the electronics housing may comprising metal and/or plastic housing and potted with aforementioned sealants and/or adhesives.

In many embodiments, the electrodes are connected to the PCB with a flex connection, for example trace **123A** of flex PCB **120**, so as to provide strain relive between the electrodes **112A**, **112B**, **112C** and **112D** and the PCB. In such embodiments, motion of the electrodes relative to the electronics modules, for example rigid PCB's **120A**, **120B**, **120C** and **120D** with the electronic components mounted thereon, does not compromise integrity of the electrode/hydrogel/skin contact. In some embodiments, the electrodes can be connected to the PCB and/or electronics module with a flex PCB **120**, such that the electrodes and adherent patch can move independently from the PCB module. In many embodiments, the flex connection comprises at least one of wires, shielded wires, non-shielded wires, a flex circuit, or a flex PCB. In specific embodiments, the flex connection may comprise insulated, non-shielded wires with loops to allow independent motion of the PCB module relative to the electrodes.

In specific embodiments, cover **162** comprises at least one of polyester, 5-25% elastane/spandex, polyamide fabric; silicone, a polyester knit, a polyester knit without elastane, or a thermoplastic elastomer. In many embodiments cover **162** comprises at least 400% elongation. In specific embodiments, cover **162** comprises at least one of a polyester knit with 10-20% spandex or a woven polyamide with 10-20% spandex. In many embodiments, cover **162** comprises a water repellent coating and/or layer on outside, for example a hydrophobic coating, and a hydrophilic coating on inside to wick moisture from body. In many embodiments the water repellent coating on the outside comprises a stain resistant coating. Work in relation to embodiments of the present invention suggests that these coatings can be important to keep excessive moisture from the gels near the electrodes and to remove moisture from body so as to provide patient comfort.

In many embodiments, cover **162** can encase the flex PCB and/or electronics and can be adhered to at least one of the electronics, the flex PCB or adherent patch **110**, so as to protect at least the electronics components and the PCB. Cover **162** can attach to adherent patch **110** with adhesive **116B**. Cover **162** can comprise many known biocompatible cover materials, for example silicone. Cover **162** can comprise an outer polymer cover to provide smooth contour without limiting flexibility. In many embodiments, cover **162** may comprise a breathable fabric. Cover **162** may comprise many known breathable fabrics, for example breathable fabrics as described above. In some embodiments, the breathable cover may comprise a breathable water resistant cover. In some embodiments, the breathable fabric may comprise polyester, nylon, polyamide, and/or elastane (Spandex™) to allow the breathable fabric to stretch with body movement. In some embodiments, the breathable tape may contain and elute a pharmaceutical agent, such as an antibiotic, anti-inflammatory or antifungal agent, when the adherent device is placed on the patient.

The breathable cover **162** and adherent patch **110** comprise breathable tape can be configured to couple continuously for at least one week the at least one electrode to the skin so as to measure breathing of the patient. The breathable tape may comprise the stretchable breathable material with the adhesive and the breathable cover may comprises a stretchable breathable material connected to the breathable tape, as described above, such that both the adherent patch and cover can stretch with the skin of the patient. The breathable cover may also comprise a water resistant material. Arrows **182** show stretching of adherent patch **110**, and the stretching of adherent patch can be at least two dimensional along the surface of the skin of the patient. As noted above, connectors **122A**, **122B**, **122C** and **122D** between PCB **130** and electrodes **112A**, **112B**, **112C** and **112D** may comprise insulated wires that provide strain relief between the PCB and the electrodes, such that the electrodes can move with the adherent patch as the adherent patch comprising breathable tape stretches. Arrows **184** show stretching of cover **162**, and the stretching of the cover can be at least two dimensional along the surface of the skin of the patient.

Cover **162** can be attached to adherent patch **110** with adhesive **116B** such that cover **162** stretches and/or retracts when adherent patch **110** stretches and/or retracts with the skin of the patient. For example, cover **162** and adherent patch **110** can stretch in two dimensions along length **170** and width **174** with the skin of the patient, and stretching along length **170** can increase spacing between electrodes. Stretching of the cover and adherent patch **110**, for example in two dimensions, can extend the time the patch is adhered to the skin as

the patch can move with the skin such that the patch remains adhered to the skin. Electronics housing **160** can be smooth and allow breathable cover **162** to slide over electronics housing **160**, such that motion and/or stretching of cover **162** is slidably coupled with housing **160**. The printed circuit board can be slidably coupled with adherent patch **110** that comprises breathable tape **110T**, such that the breathable tape can stretch with the skin of the patient when the breathable tape is adhered to the skin of the patient, for example along two dimensions comprising length **170** and width **174**.

The stretching of the adherent device **100** along length **170** and width **174** can be characterized with a composite modulus of elasticity determined by stretching of cover **162**, adherent patch **110** comprising breathable tape **110T** and gel cover **180**. For the composite modulus of the composite fabric cover-breathable tape-gel cover structure that surrounds the electronics, the composite modulus may comprise no more than about 1 MPa, for example no more than about 0.3 MPa at strain of no more than about 5%. These values apply to any transverse direction against the skin.

The stretching of the adherent device **100** along length **170** and width **174**, may also be described with a composite stretching elongation of cover **162**, adherent patch **110** comprising breathable tape **110T** and gel cover **180**. The composite stretching elongation may comprise a percentage of at least about 10% when 3 kg load is applied, for example at least about 100% when the 3 kg load applied. These percentages apply to any transverse direction against the skin.

The printed circuit board may be adhered to the adherent patch **110** comprising breathable tape **110T** at a central portion, for example a single central location, such that adherent patch **110** can stretch around this central region. The central portion can be sized such that the adherence of the printed circuit board to the breathable tape does not have a substantial effect of the modulus of the composite modulus for the fabric cover, breathable tape and gel cover, as described above. For example, the central portion adhered to the patch may be less than about 100 mm², for example with dimensions of approximately 10 mm by 10 mm (about 0.5" by 0.5"). Such a central region may comprise no more than about 10% of the area of patch **110**, such that patch **110** can stretch with the skin of the patient along length **170** and width **174** when the patch is adhered to the patient.

The cover material may comprise a material with a low recovery, which can minimize retraction of the breathable tape from the pulling by the cover. Suitable cover materials with a low recovery include at least one of polyester or nylon, for example polyester or nylon with a loose knit. The recovery of the cover material may be within a range from about 0% recovery to about 25% recovery. Recovery can refer to the percentage of retraction the cover material that occurs after the material has been stretched from a first length to a second length. For example, with 25% recovery, a cover that is stretched from a 4 inch length to a 5 inch length will retract by 25% to a final length of 4.75 inches.

Electronics components **130** can be affixed to printed circuit board **120**, for example with solder, and the electronics housing can be affixed over the PCB and electronics components, for example with dip coating, such that electronics components **130**, printed circuit board **120** and electronics housing **160** are coupled together. Electronics components **130**, printed circuit board **120**, and electronics housing **160** are disposed between the stretchable breathable material of adherent patch **110** and the stretchable breathable material of cover **160** so as to allow the adherent patch **110** and cover **160** to stretch together while electronics components **130**, printed

circuit board **120**, and electronics housing **160** do not stretch substantially, if at all. This decoupling of electronics housing **160**, printed circuit board **120** and electronic components **130** can allow the adherent patch **110** comprising breathable tape to move with the skin of the patient, such that the adherent patch can remain adhered to the skin for an extended time of at least one week, for example two or more weeks.

An air gap **169** may extend from adherent patch **110** to the electronics module and/or PCB, so as to provide patient comfort. Air gap **169** allows adherent patch **110** and breathable tape **110T** to remain supple and move, for example bend, with the skin of the patient with minimal flexing and/or bending of printed circuit board **120** and electronic components **130**, as indicated by arrows **186**. Printed circuit board **120** and electronics components **130** that are separated from the breathable tape **110T** with air gap **169** can allow the skin to release moisture as water vapor through the breathable tape, gel cover, and breathable cover. This release of moisture from the skin through the air gap can minimize, and even avoid, excess moisture, for example when the patient sweats and/or showers.

The breathable tape of adherent patch **110** may comprise a first mesh with a first porosity and gel cover **180** may comprise a breathable tape with a second porosity, in which the second porosity is less than the first porosity to minimize, and even inhibit, flow of the gel through the breathable tape. The gel cover may comprise a polyurethane film with the second porosity.

Cover **162** may comprise many shapes. In many embodiments, a geometry of cover **162** comprises at least one of oblong, oval, butterfly, dogbone, dumbbell, round, square, rectangular with rounded corners, or polygonal with rounded corners. In specific embodiments, the geometric of cover **162** comprises at least one of an oblong, an oval or a round shape.

Cover **162** may comprise many thicknesses and/or weights. In many embodiments, cover **162** comprises a fabric weight: within a range from about 100 to about 200 g/m², for example a fabric weight within a range from about 130 to about 170 g/m².

In many embodiments, cover **162** can attach the PCB module to adherent patch **110** with cover **162**, so as to avoid interaction of adherent patch **110C** with the PCB having the electronics mounted therein. Cover **162** can be attached to breathable tape **110T** and/or electronics housing **160** comprising over the encapsulated PCB. In many embodiments, adhesive **116B** attaches cover **162** to adherent patch **110**. In many embodiments, cover **162** attaches to adherent patch **110** with adhesive **116B**, and cover **162** is adhered to the PCB module with an adhesive **161** on the upper surface of the electronics housing. Thus, the PCB module can be suspended above the adherent patch via connection to cover **162**, for example with a gap **169** between the PCB module and adherent patch. In many embodiments, gap **169** permits air and/or water vapor to flow between the adherent patch and cover, for example through adherent patch **110** and cover **162**, so as to provide patient comfort.

In many embodiments, adhesive **116B** is configured such that adherent patch **110** and cover **162** can be breathable from the skin to above cover **162** and so as to allow moisture vapor and air to travel from the skin to outside cover **162**. In many embodiments, adhesive **116B** is applied in a pattern on adherent patch **110** such that the patch and cover can be flexible so as to avoid detachment with body movement. Adhesive **116B** can be applied to upper side **110B** of patch **110** and comprise many shapes, for example a continuous ring, dots, dashes around the perimeter of adherent patch **110** and cover **162**. Adhesive **116B** may comprise at least one of acrylate, sili-

cone, synthetic rubber, synthetic resin, pressure sensitive adhesive (PSA), or acrylate pressure sensitive adhesive. Adhesive **16B** may comprise a thickness within a range from about 0.0005" to about 0.005", for example within a range from about 0.001-0.005". In many embodiments, adhesive **116B** comprises a width near the edge of patch **110** and/or cover **162** within a range from about 2 to about 15 mm, for example from about 3 to about 7 near the periphery. In many embodiments with such widths and/or thickness near the edge of the patch and/or cover, the tissue adhesion may be at least about 30 oz/in, for example at least about 40 oz/in, such that the cover remains attached to the adhesive patch when the patient moves.

In many embodiments, the cover is adhered to adherent patch **110** comprising breathable tape **110T** at least about 1 mm away from an outer edge of adherent patch **110**. This positioning protects the adherent patch comprising breathable tape **110T** from peeling away from the skin and minimizes edge peeling, for example because the edge of the patch can be thinner. In some embodiments, the edge of the cover may be adhered at the edge of the adherent patch, such that the cover can be slightly thicker at the edge of the patch which may, in some instances, facilitate peeling of the breathable tape from the skin of the patient.

Gap **169** extend from adherent patch **110** to the electronics module and/or PCB a distance within a range from about 0.25 mm to about 4 mm, for example within a range from about 0.5 mm to about 2 mm.

In many embodiments, the adherent device comprises a patch component and at least one electronics module. The patch component may comprise adherent patch **110** comprising the breathable tape with adhesive coating **116A**, at least one electrode, for example electrode **114A** and gel **114**. The at least one electronics module can be separable from the patch component. In many embodiments, the at least one electronics module comprises the flex printed circuit board **120**, electronic components **130**, electronics housing **160** and cover **162**, such that the flex printed circuit board, electronic components, electronics housing and cover are reusable and/or removable for recharging and data transfer, for example as described above. In many embodiments, adhesive **116B** is coated on upper side **110A** of adherent patch **110B**, such that the electronics module can be adhered to and/or separated from the adhesive component. In specific embodiments, the electronic module can be adhered to the patch component with a releasable connection, for example with Velcro™, a known hook and loop connection, and/or snap directly to the electrodes. Two electronics modules can be provided, such that one electronics module can be worn by the patient while the other is charged, as described above. Monitoring with multiple adherent patches for an extended period is described in U.S. Pat. App. No. 60/972,537, the full disclosure of which has been previously incorporated herein by reference. Many patch components can be provided for monitoring over the extended period. For example, about 12 patches can be used to monitor the patient for at least 90 days with at least one electronics module, for example with two reusable electronics modules.

In many embodiments, the adherent device comprises a patch component and at least one electronics module. The patch component may comprise adherent patch **110** comprising the breathable tape with adhesive coating **116A**, at least one electrode, for example electrode **114A** and gel **114**. The at least one electronics module can be separable from the patch component. In many embodiments, the at least one electronics module comprises the flex printed circuit board **120**, electronic components **130**, electronics housing **160** and cover

162, such that the flex printed circuit board, electronic components, electronics housing and cover are reusable and/or removable for recharging and data transfer, for example as described above. In many embodiments, adhesive 116B is coated on upper side 110A of adherent patch 110B, such that the electronics module can be adhered to and/or separated from the adhesive component. In specific embodiments, the electronic module can be adhered to the patch component with a releasable connection, for example with Velcro™, a known hook and loop connection, and/or snap directly to the electrodes. Two electronics modules can be provided, such that one electronics module can be worn by the patient while the other is charged, as described above. Monitoring with multiple adherent patches for an extended period is described in U.S. Pat. App. No. 60/972,537, the full disclosure of which has been previously incorporated herein by reference. Many patch components can be provided for monitoring over the extended period. For example, about 12 patches can be used to monitor the patient for at least 90 days with at least one electronics module, for example with two reusable electronics modules.

At least one electrode 112A can extend through at least one aperture 180A in the breathable tape 110 and gel cover 180.

In some embodiments, the adhesive patch may comprise a medicated patch that releases a medicament, such as antibiotic, beta-blocker, ACE inhibitor, diuretic, or steroid to reduce skin irritation. The adhesive patch may comprise a thin, flexible, breathable patch with a polymer grid for stiffening. This grid may be anisotropic, may use electronic components to act as a stiffener, may use electronics-enhanced adhesive elution, and may use an alternating elution of adhesive and steroid.

FIG. 1K shows at least one electrode 190 configured to electrically couple to a skin of the patient through a breathable tape 192. In many embodiments, at least one electrode 190 and breathable tape 192 comprise electrodes and materials similar to those described above. Electrode 190 and breathable tape 192 can be incorporated into adherent devices as described above, so as to provide electrical coupling between the skin an electrode through the breathable tape, for example with the gel.

FIG. 2 shows a method 200 of monitoring a person.

A step 205 adheres a measurement device to patient to measure heart rate, activity, body posture, respiration rate and bioimpedance. The adherent device may comprise an adherent device as described above. The device may comprise ECG circuitry to measure the HR, an accelerometer to measure patient activity and orientation, impedance circuitry to measure breathing and patient hydration. Additional or alternative sensors can be used. For example, breathing may be determined with a sensor that provides a signal in response to expansion of the chest and expansion of the skin of the patient.

A step 210 measures, stores and processes patient data with adherent device. The adherent device may measure HR, patient activity and orientation, breathing and hydration, and these data can be stored on the adherent device, for example stored on the processor at least prior to communication with the gateway. The processor may determine a heart rate of the patient based on the ECG and may determine hydration and breathing based on an impedance signal from the impedance circuitry, for example.

A step 212 determines patient drug treatment. The drug treatment can be determined based on a prescription from a physician, for example.

A step 215 transmits patient data from adherent device to the gateway, as described above. A step 220 receives the patient data with the gateway.

A step 225 measures, stores and processes patient data with gateway. The gateway can store data of the adherent device and process the data. For example, the gateway can perform one or more of the steps of sub-steps so as to identify the CI. Also, the gateway may comprise at least one sensor to measure additional patient data, and may also combine data with data from additional measurement devices.

A step 230 transmits patient data from the gateway to the remote server.

A step 235 stores and processed patient data with remote server. The remote server can store data of the adherent device and process the data. For example, the remote server can perform one or more of the steps of sub-steps so as to identify the CI.

A step 240 identifies functional CI with profile of remote heart rates. This functional CI can be identified in many ways, for example with one or more measurement of location of the heart rate data, measures of dispersion and variability of the heart rate data, skewness and kurtosis of the heart rate data, or comparison of portions around a mode of a single modal mound distribution.

A sub-step 241—determines a profile of remote heart rates. A sub-step 242 determines a peak of the profile of remote heart rates. For example, the profile may comprise a histogram or Gaussian probability function and the peak may comprise the mode of the distribution or probability function.

A sub-step 243 determines a portion of profile above peak. A sub-step 244 determines a portion of profile below peak. A sub-step 245 compares a portion above peak to a portion below peak. A sub-step 246 identifies functional CI when the portion above peak is less than portion below. For example, the portion above may correspond to the occurrence of heart rates above the peak heart rate and the portion below the peak may correspond to the occurrence of heart rates below the peak.

Based on the teachings described herein one can determine relevant parameters from the heart rate distribution profile so as to identify the functional CI.

A step 250 identifies functional CI with resting remote HR. A sub-step 251—determines the occurrence of heart rates corresponding to profile. A sub-step 252 determines a peak of the remote heart rates. A sub-step 253 determines the peak of remote heart rates. A sub-step 254 determine the remote resting HR based on the peak of the remote HR. A sub-step 255 determines age corrected maximum HR. A sub-step 256 determines the HRR based on age corrected maximum HR and remote resting HR. A sub-step 257 identifies functional CI when the HRR is below the threshold.

A step 260 identifies functional CI with maximum HR. A sub-step 261 determines the threshold activity amount based on patient data from a plurality of other patients, for example from a patient population measured with substantially similar adherent devices when the patients are at home. A sub-step 262 determines the patient activity above threshold. A sub-step 263 determines heart rates of the patient corresponding to patient activity above threshold. For example, the heart rate of the patient may comprise a maximum HR of the patient and the maximum HR of the patient can be compared to the threshold. A sub-step 264 determines a correlation of HR above threshold with one or more of activity, body posture, respiration rate and bioimpedance. A sub-step 265 determines patient drug treatment and compliance. A sub-step 266 determines functional CI based on patient drug treatment and correlation of HR above threshold with the one or more of

activity, body posture, respiration rate or bioimpedance. A step 270 transmits notification to one or more of physician or patient based on identification of CI.

The 85% cut-off for functional CI classification can be modified to other cut-offs to account for pharmacological modification of heart rate response such as beta-blockers and other chronotropic/lusitropic medication.

The processor system, as described above, may comprise instructions of a computer program embedded thereon so as to perform many of the steps of the method 200. For example, many of the steps of the method 200 can be performed with processor system comprising the processor of the adherent device, the processor of the gateway and the processor of the remote server. The method 200 can be performed with one or more of the processor of the adherent device, the processor of the gateway and the processor of the remote server. Further the steps of the method 200 can be distributed among the processor of the processor system such that each processor performs at least one of the steps or sub-steps of method 200.

It should be appreciated that the specific steps illustrated in FIG. 2 provide a particular method of monitoring a patient and responding to a signal event, in accordance with an embodiment of the present invention. Other sequences of steps may also be performed in accordance with alternative embodiments. For example, alternative embodiments of the present invention may perform the steps outlined above in a different order. Moreover, the individual steps illustrated in FIG. 2 may include multiple sub-steps that may be performed in various sequences as appropriate to the individual step. Alternatively, the multiple sub-steps may be performed as an individual step. Furthermore, additional steps may be added or removed depending on the particular applications. One of ordinary skill in the art would recognize many variations, modifications, and alternatives.

The patient data as described above can be combined to determine the functional CI of the patient. For example, the data can be combined with one or more correlations of heart rate to one or more of the activity index (hereinafter "AI"), body posture (hereinafter "BP"), impedance of the patient (hereinafter "BioZ" or respiration rate (hereinafter "RR"). The AI may comprise an index based on the measurements from the three axes of the accelerometer as described above. The BP may comprise an angle of the patient based on orientation from accelerometer as described above. The BioZ may comprise impedance averaged over patient breathing cycles to correct for patient breathing or corrected for patient breathing with a portion of the breathing pattern. For example, the heart rate can be correlated with these data with the equation:

$$HR=a*AI+b*BP+c*BioZ+d*RR,$$

where a, b, c and d are respective correlation coefficients. The above equation is merely an example of a correlation equation as many additional equations can be used such as equations with cross terms, for example of AI with BP, and with squared terms, for example with coefficients of (BP)*(BP).

The patient data may also be combined with multi-dimensional look up tables, for example with look up tables comprising levels or tiers for each measured data parameter such as AI. For example, AI may comprise a level, or tier, based on counts of an accelerometer or other index.

Embodiments as described herein can be incorporated with many commercially available patient monitoring and treatment systems such as the OptiVol™ alert algorithm and computer programs embodying instructions thereof commercially available from Medtronic, the CareLink™ server commercially available from Medtronic, the Latitude™

patient management system commercially available from Boston Scientific, the Merlin™ system commercially available from St. Jude and the MCOT™ commercially available from CardioNet.

Experimental Clinical Studies

An experimental clinical study can be conducted on an empirical number of patients to determine empirically parameters of the above described adherent device and processor system so as to determine functional CI of the patient. The empirically determined parameters can be used with programs of the processor system to determine status of the patient, for example to determine deterioration in the status, based on the teachings as described herein.

FIGS. 3A1 to 3A5 show heart rate, activity index, body posture, impedance, and respiration rate measured from an adherent device adhered to the skin of the patient. Although the device can be adhered for at least about one week as described above, the data of FIG. 3A show at least about 24 hours of measured data to show an example of data suitable for combination. Each of FIGS. 3A1 to 3A5 have a corresponding time base, for example from a data time stamp of the processor of the adherent device.

FIG. 3A1 shows the heart rate of the patient in beats per minute from 00:00 hours to 24:00 hours. The heart rate may be determined with one or more of the processor of the adherent device, the processor of the gateway or the processor of the remote server. The HR shows an elevation at about 11:00.

FIG. 3A2 shows patient activity amounts. The patient activity amounts may comprise an index and many measures of patient activity. For example, the activity index may comprise counts and/or an arbitrary scale, and the values can range from about 0 to about 300. The data show a peak at about 11:00.

FIG. 3A3 shows patient body posture angle. The patient body posture is shown to be upright, at around 80 degrees from about 07:00 to about 18:00. These data indicate that the patient is awake and upright from about 07:00 to about 18:00.

FIG. 3A4 shows patient impedance. The patient impedance is shown to vary from about 60 to about 80 Ohms. For example with local peaks around 11:00 and 14:00 corresponding to about 74 and 78 Ohms, respectively.

FIG. 3A5 shows patient breathing rate, also referred to as patient respiration rate. The respiration rate of the patient varies from about 10 breaths per minute to about 30 breaths per minute.

Based on the teachings described herein, the instruction of the processor system can identify functional CI from the HR data and data of one or more of the other sensors. The method and instructions of the processor system can identify functional CI of the patient based on HR and one or more sensors from about 10:00 to 11:00. For example, the patient activity comprises a peak around 11 am corresponding to an activity amount above the threshold determined with similar adherent devices from a population of patients or relative to the patient's own activity mean over a given 24 hour period. For example, the threshold may correspond to an activity amount of 100, such that the patient heart rates corresponding to the activity index above the threshold of 100 correspond to maximum HR of the patient. The processor system comprises patient data including the age of the patient such that the age corrected maximum HR can be determined and the functional CI of the patient can be identified based on the age corrected maximum HR and the maximum HR of the patient. The increase in activity was not paralleled by a comparable increase in HR so as to comprise a diagnostic marker to identify CI with the remote patient measurements as described herein.

The processor system and methods described herein can identify functional CI of the patient based on the profile of the HR data, for example based on histogram as described herein.

FIG. 3B shows patient data measured remotely with an adherent device as described above. The patient data shows a distribution comprising a histogram for a first patient without functional CI and a second patient with functional CI. The patient heart rate data may comprise data measured during the day when the patient is active. The data may comprise a modal heart rate distribution. The data show a histogram for each patient. The heart rate of each patient is determined over time. The occurrence of heart rate in 5 beat per minute intervals is shown from 50 beats per minute to 140 beats per minute. The patient with no functional CI shows a peak at about 90 beats per minute, and the patient with functional CI shows a peak at about 105 beats per minute.

The functional CI can be identified with the profile of remote heart rates. This functional CI can be identified in many ways, for example with one or more measurement of location of the heart rate data, measures of dispersion and variability of the heart rate data, skewness and kurtosis of the heart rate data, or comparison of portions around a mode of a single modal mounded distribution.

The histogram distribution of each patient comprises a first side corresponding to a first amount of occurrences of heart rates below the peak and a second side corresponding to a second amount of occurrences of heart rates above the peak. The distribution of the first patient without functional CI has a first amount of occurrences below the peak at 90 bpm and a second amount of occurrence above the peak at 90 bpm, and the first amount is substantially equal to the second amount. The distribution of the second patient with functional CI has a first amount of occurrences below the peak at 105 bpm and a second amount of occurrence above the peak at 105 bpm, and the first amount is substantially greater than the second amount.

Alternatively or in combination, the histogram distribution of each patient can be fit to a Gaussian distribution and a skew of the distribution for each patient determined. For example, the first patient without functional CI comprises substantially no skew of the histogram distribution, and the second patient with functional CI comprises significant skew of the histogram distribution.

The peak of the HR data of FIG. 3B corresponds to the resting HR of the patient, such that the HRR of the patient can be calculated. The HRR can be combined with the profile from the histogram to identify the patient CI.

FIG. 3C shows average maximum activity of patients based on age for ages from about 20 to about 90. These average maximum activity levels from a population of patients can be used to determine threshold criteria and correlate activity with additional measurement parameters, such as heart rate and change in heart rate.

Clinical Studies for Remote Monitoring and Diagnosis of Chronotropic Incompetence in HF patients.

A study can be conducted to diagnose functional CI during activities of daily living, through remote monitoring, so as to provide important information for effectively managing HF and understanding the role of functional CI in contributing to HF symptoms. The study may comprise HF patients having an ejection fraction (hereinafter "EF") of 40% or less.

Study Design: The study may comprise a prospective monitoring study of patients with chronic HF using an external multi-sensor monitor, for example an adherent monitor as described above. The study may comprise data from multiple centers and enroll approximately 200 enrolled patients with NYHA Class III/IV, EF \leq 40%. The wireless monitoring

device can be applied to the patient's chest and replaced weekly during a 90-day monitoring period. Heart rate (HR), respiratory rate, activity level and body impedance data from the device were transmitted at regular interval via phone and used for offline analysis.

The data can be analyzed to determine results and compare the determined functional CI to similar study populations. The following can be determined for the population: gender, age, body mass index, EF, percentage of patient with beta-blockers. For each patient, the modal HR during daily activity was calculated and used to perform functional CI determination. The percentage of patients with functional CI can be determined when defined as an inability to reach 85% of age-predicted maximum HR. When adjusted for beta-blocker use, the percentage of patient having functional CI can be determined.

Applicants note that a study design as described above has been conducted on a population of approximately 300 patients.

FIG. 3D1 shows correlation of heart rate data with activity data for patients without functional CI from the study. The fit parameters are $HR \text{ (bpm)} = 0.0985 * (\text{Activity}) + 75.4$ ($R^2 = 0.151$)

FIG. 3D2 shows correlation of heart rate data with activity data for patients with functional CI from the study. The fit parameters are $HR \text{ (bpm)} = 0.0126 * (\text{Activity}) + 82.651$ ($R^2 = 0.0026$)

The correlations shown in FIGS. 3D1 and 3D2 are examples of linear correlations of heart rate with activity that can be determined. The correlation coefficient of the patients without functional CI shows a steeper slope for a linear fit between HR and activity when compared to patients with functional CI. The less steep curve of the patients with CI shows a blunting of heart rate response to activities of daily living, when adjusted for age. This blunting of HR elevation can be combined with additional patient measurement data, as described above.

Applicants note that the presence of functional CI in the study was determined based on measured activity above a percentage of the mean age adjusted maximum heart rate as shown above with reference to FIG. 3C. This measured activity above the threshold amount can be used to determine the presence of functional CI. Based on this crossing of measured patient activity above the threshold and the corresponding HR can be used to identify the patient as having functional CI or not having functional CI. Of approximately 300 patients, about 29% of the patients were determined to have functional CI and approximately 12% were determined to have no functional CI. For the remaining 59% of the patients, the functional CI was indeterminate based on activity and heart rate due to the sedentary status of the patient. However, Applicants note that additional patient measurement data can be used to identify the functional CI in accordance with additional steps of method 300 described above, such that the presence (or absence) of functional CI can be positively determined for a majority of patients. For example the profile of the HR distribution and the heart rate reserve of the patient as measured at home can be used to determine the presence of functional CI.

Additional correlations and correspondence among patient data can be made with additional variables as described above so as to identify functional CI in a patient population. The correlations may comprise a plurality of variables correlated with the HR profile, as described above. Look up tables can also be determined to compare functional CI with measurement data such as activity, orientation, activity, respiration rate and body temperature.

While the exemplary embodiments have been described in some detail, by way of example and for clarity of understanding, those of skill in the art will recognize that a variety of modifications, adaptations, and changes may be employed. Hence, the scope of the present invention should be limited solely by the appended claims.

What is claimed is:

1. An apparatus to monitor a patient, the apparatus comprising,
 - a processor system comprising at least one processor having a tangible medium with instructions of a computer program embodied thereon, the processor system configured to receive heart rate data of the patient, the heart rate data comprising a plurality of measurements of the patient's heart rate taken over a period of time under a variety of conditions of daily living on the part of the patient, wherein the period of time encompasses a variety of activity levels on the part of the patient, and the heart rate data includes heart rates measured while the patient is at rest and heart rates measured while the patient is active; construct a histogram of the measurements of the patient's heart rate; and identify chronotropic incompetence of the patient based on the shape of the histogram; wherein the computer program comprises instructions to determine a peak of the histogram and a first portion of the histogram and a second portion of the histogram, the first portion corresponding to a first amount of occurrences of first heart rates lower than the heart rate corresponding to the peak and the second portion corresponding to a second amount of occurrences of second heart rates greater than the heart rate corresponding to the peak and wherein the chronotropic incompetence is identified based on the second amount smaller than the first amount.
 2. The apparatus of claim 1 wherein the computer program comprises instructions to identify the chronotropic incompetence with one or more of measures of dispersion and variability of the heart rate data, skewness and kurtosis of the heart rate data, or comparison of portions around a mode of a single modal mounded distribution.
 3. The apparatus of claim 1, wherein the patient is a remote patient.
 4. The apparatus of claim 1 wherein the computer program comprises instructions to receive respiration data of the patient and activity data of the patient and instructions to combine the heart rate data with the respiration data and activity data to identify the chronotropic incompetence.
 5. A method of monitoring a patient, the method comprising,
 - measuring heart rate data of the patient, the heart rate data comprising a plurality of measurements of the patient's heart rate taken over a period of time under a variety of conditions of daily living on the part of the patient, wherein the period of time encompasses a variety of activity levels on the part of the patient, and the heart rate data includes heart rates measured while the patient is at rest and heart rates measured while the patient is active; providing a processor system comprising at least one processor having a tangible medium with instructions of a computer program embodied thereon; receiving, by the processor under control of the computer program, the heart rate data of the patient; constructing, by the processor, a histogram of the measurements of the patient's heart rate;

- determining a peak of the histogram and a first portion of the histogram and a second portion of the histogram, the first portion corresponding to a first amount of occurrences of first heart rates lower than the heart rate corresponding to the peak and the second portion corresponding to a second amount of occurrences of second heart rates greater than the heart rate corresponding to the peak; and identifying chronotropic incompetence based on the second amount smaller than the first amount.
 6. An apparatus to monitor a patient having a skin, the apparatus comprising,
 - an adherent device to measure patient data comprising wireless communication circuitry and measurement circuitry, the measurement circuitry coupled to at least two electrodes, a respiration sensor and an activity sensor, the adherent device comprising a support with an adhesive to adhere the at least two electrodes to the skin and support the wireless communication circuitry, the processor circuitry and the measurement circuitry with the skin;
 - a server located remote from the patient to receive the patient data; and
 - a gateway coupled to each of the adherent device and the server with wireless communication to transmit the patient data; wherein one or more of the adherent device, the server or the gateway comprises at least one processor having a tangible memory medium with instructions of a computer program embodied thereon to determine a chronotropic incompetence of the patient based on the patient data measured with the at least two electrodes, the respiration sensor and the activity sensor;
 - and wherein the computer program comprises instructions to determine a histogram of heart rate data comprising a plurality of measurements of the patient's heart rate taken over a period of time under a variety of conditions of daily living on the part of the patient, wherein the period of time encompasses a variety of activity levels on the part of the patient, and the heart rate data includes heart rates measured while the patient is at rest and heart rates measured while the patient is active;
 - and wherein the at least one processor is configured to determine a peak of the histogram and a first portion of the histogram and a second portion of the histogram, the first portion corresponding to a first amount of occurrences of first heart rates lower than the heart rate corresponding to the peak and the second portion of the histogram corresponding to a second amount of occurrences of second heart rates greater than the heart rate corresponding to the peak and wherein the processor is configured to determine chronotropic incompetence based on the second amount smaller than the first amount.
 7. The apparatus of claim 6 wherein the at least one processor comprises instructions to fit the histogram to a Gaussian distribution and determine a skew of the distribution and wherein the chronotropic incompetence is determined based on the skew.
 8. The apparatus of claim 6 wherein the at least one processor comprises instructions to determine a distribution of heart rates of the patient, the distribution corresponding heart rates less than a maximum heart rate of the patient and wherein the at least one processor is configured to determine the chronotropic incompetence based on the distribution heart rate intervals corresponding to less than the maximum heart rate of the patient.

9. The apparatus of claim 6 wherein the at least one processor comprises instructions to determine a distribution of heart rates of the patient, the distribution corresponding to heart rates less than a maximum heart rate of the patient and wherein the at least one processor comprises instructions to determine the maximum heart rate of the patient based on the distribution heart rate intervals corresponding to less than the maximum heart rate of the patient.

10. The apparatus of claim 9 wherein the at least one processor comprises instructions to determine the chronotropic incompetence of the patient based on the maximum heart rate of the patient.

11. The apparatus of claim 6 wherein the at least one processor comprises instructions to determine the maximum heart rate of the patient based on the distribution of heart rates corresponding to less than the maximum heart rate of the patient.

12. A method of monitoring a patient, the method comprising: measuring heart rate data of the patient, wherein the heart rate data includes a plurality of measurements of the patient's heart rate taken over a period of time under a variety of conditions of daily living on the part of the patient, wherein the period of time encompasses a variety of activity levels on the part of the patient, and the

heart rate data includes heart rates measured while the patient is at rest and heart rates measured while the patient is active;

providing a processor system comprising at least one processor having a tangible medium with instructions of a computer program embodied thereon, wherein the processor system receives heart rate data measured over a period of time from the patient and determines a histogram of the heart rates and wherein the processor determines a peak of the histogram and a first portion of the histogram and a second portion of the histogram, the first portion corresponding to a first amount of occurrences of first heart rates lower than the heart rate corresponding to the peak and the second portion of the histogram corresponding to a second amount of occurrences of second heart rates greater than the heart rate corresponding to the peak and wherein the processor determines chronotropic incompetence based on the second amount smaller than the first amount.

13. The method of claim 12 the heart rate data comprise data measured from a patch adhered to the patient for at least about one week and wherein the heart rate data is transmitted with wireless communication.

* * * * *

专利名称(译)	用于远程检测和监测功能性变时性功能不全的方法和装置		
公开(公告)号	US8790259	公开(公告)日	2014-07-29
申请号	US12/910076	申请日	2010-10-22
[标]申请(专利权)人(译)	科文迪斯有限公司		
申请(专利权)人(译)	CORVENTIS INC.		
当前申请(专利权)人(译)	CORVENTIS INC.		
[标]发明人	KATRA RODOLPHE CHAKRAVARTHY NIRANJAN LIBBUS IMAD		
发明人	KATRA, RODOLPHE CHAKRAVARTHY, NIRANJAN LIBBUS, IMAD		
IPC分类号	A61B5/02 A61B5/053 A61B5/11 A61B5/08 A61B5/00 A61B5/0245 A61B5/0205		
CPC分类号	A61B5/0002 A61B5/0537 A61B5/1118 A61B5/0245 A61B5/0205 A61B5/0816 A61B2560/0412 A61B5/08 A61B5/1116 A61B5/024 A61B5/7246 A61B5/7275 A61B5/746		
代理机构(译)	KILPATRICK TOWNSEND & STOCKTON LLP		
优先权	61/253866 2009-10-22 US		
其他公开文献	US20110270049A1		
外部链接	Espacenet USPTO		

摘要(译)

在日常生活条件下确定家庭环境中功能性变时性功能不全（以下称“CI”）的存在和跟踪的方法和装置。可以利用测量的患者心率的分布，测量的最大患者心率或心率分布的峰值中的一个或多个来确定患者的功能CI。可以利用测量的心率分布来确定患者的功能CI，其中测量的心率分布可以对应于基本上小于患者的最大心率的心率，使得当心率可以安全地测量时患者远离医疗保健提供者。可以基于远程测量的心率分布的峰值来确定患者的功能CI，例如对应于心率分布简档的模式峰值。

