



US008452367B2

(12) **United States Patent**
Mannheimer et al.

(10) **Patent No.:** **US 8,452,367 B2**
(45) **Date of Patent:** ***May 28, 2013**

(54) **FOREHEAD SENSOR PLACEMENT**

(75) Inventors: **Paul D. Mannheimer**, Danville, CA (US); **Don L. Hannula**, San Luis Obispo, CA (US); **Donald E. Bebout**, Lake Oswego, OR (US); **Michael Patrick O'Neil**, Danville, CA (US)

(73) Assignee: **Covidien LP**, Mansfield, MA (US)

(*) Notice: Subject to any disclaimer, the term of this patent is extended or adjusted under 35 U.S.C. 154(b) by 212 days.

This patent is subject to a terminal disclaimer.

(21) Appl. No.: **12/843,651**

(22) Filed: **Jul. 26, 2010**

(65) **Prior Publication Data**

US 2011/0009723 A1 Jan. 13, 2011

Related U.S. Application Data

(60) Continuation of application No. 11/495,195, filed on Jul. 28, 2006, now Pat. No. 7,822,453, which is a division of application No. 10/678,040, filed on Oct. 1, 2003, now Pat. No. 7,289,837.

(60) Provisional application No. 60/415,468, filed on Oct. 1, 2002.

(51) **Int. Cl.**
A61B 5/1455 (2006.01)

(52) **U.S. Cl.**
USPC **600/344**; 600/340

(58) **Field of Classification Search**
USPC 600/310, 322, 323, 340, 344
See application file for complete search history.

(56) **References Cited**

U.S. PATENT DOCUMENTS

1,304,215	A *	5/1919	Snyder	2/181
1,899,020	A *	2/1933	Drueding	2/181
4,025,733	A	5/1977	Klar et al.	
4,047,400	A	9/1977	Thorneburg	
4,321,930	A	3/1982	Jobsis et al.	
4,462,116	A	7/1984	Sanzone et al.	

(Continued)

FOREIGN PATENT DOCUMENTS

CN	1306260	8/2001
CN	1657007	8/2005

(Continued)

Primary Examiner — Eric Winakur

(74) *Attorney, Agent, or Firm* — Fletcher Yoder

(57) **ABSTRACT**

Forehead oximetry sensor devices and methods for determining physiological parameters using forehead oximetry sensors. One method includes placing an oximetry sensor on the forehead of a patient, such that the sensor is placed on the lower forehead region, above the eyebrow with the sensor optics placed lateral of the iris and proximal the temple; and operating the pulse oximeter to obtain the physiological parameter. In one aspect, the method also includes providing and placing a headband over the oximetry sensor, or alternatively, the sensor is a headband-integrated sensor. The headband has an elastic segment sized to fit around the patient's head. The headband also includes a non-elastic segment that is smaller than and attached with the elastic segment. The non-elastic segment is sized to span a portion of the elastic segment when the elastic segment is stretched. In addition, the non-elastic segment is larger than the portion of the elastic segment it spans when the elastic segment is not stretched. When the headband or the headband-integrated sensor is sufficiently tight, it delivers a pressure in the range higher than the venous pressure and lower than the capillary pressure to the forehead of the patient.

18 Claims, 8 Drawing Sheets

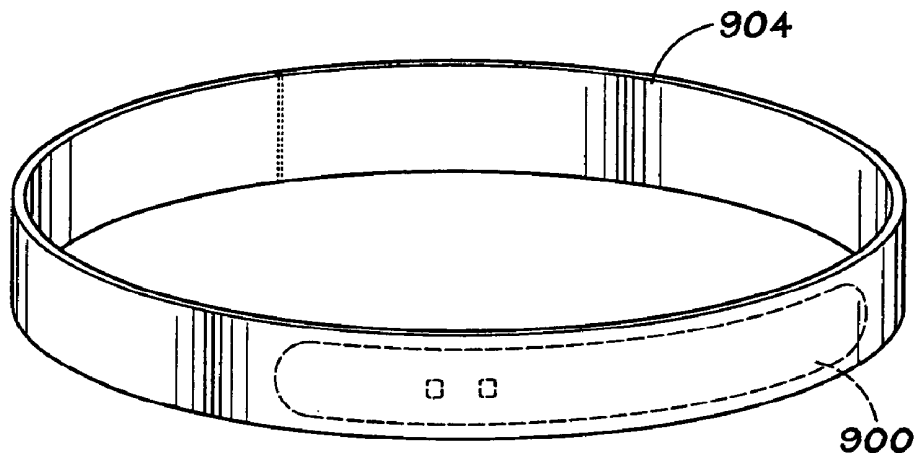

U.S. PATENT DOCUMENTS							
4,499,741	A	2/1985	Harris	5,551,423	A	9/1996	Sugiura
4,510,938	A	4/1985	Jobsis et al.	5,562,718	A	10/1996	Palermo
4,570,638	A	2/1986	Stoddart et al.	5,564,108	A	10/1996	Hunsaker et al.
4,675,919	A	6/1987	Heine et al.	5,564,417	A	10/1996	Chance
4,739,757	A	4/1988	Edwards	5,584,296	A	12/1996	Cui et al.
4,775,116	A	10/1988	Klein	5,592,408	A	1/1997	Keskin et al.
4,784,162	A	11/1988	Ricks et al.	5,596,987	A	1/1997	Chance
4,802,485	A	2/1989	Bowers et al.	5,617,865	A	4/1997	Palczewska et al.
4,825,872	A	5/1989	Tan et al.	5,617,866	A	4/1997	Marian, Jr.
4,825,879	A	5/1989	Tan et al.	5,627,323	A	5/1997	Stern
4,833,734	A	5/1989	Der Estephanian	5,634,466	A	6/1997	Gruner
4,838,279	A	6/1989	Fore	5,638,593	A	6/1997	Gerhardt et al.
4,856,116	A	8/1989	Sullivan	5,638,818	A	6/1997	Diab et al.
4,890,619	A	1/1990	Hatschek	5,640,953	A	6/1997	Bishop et al.
4,910,804	A	3/1990	Lidgren	5,645,059	A	7/1997	Fine et al.
4,911,167	A	3/1990	Corenman et al.	5,645,440	A	7/1997	Tobler et al.
4,918,758	A	4/1990	Rendina	5,645,586	A	7/1997	Meltzer
4,930,888	A	6/1990	Feisleben et al.	5,646,416	A	7/1997	Van De Velde
4,942,877	A	7/1990	Sakai et al.	5,671,750	A	9/1997	Shinoda
4,972,331	A	11/1990	Chance	5,673,708	A	10/1997	Athanasίου et al.
4,977,011	A	12/1990	Smith	5,678,544	A	10/1997	DeLonzor et al.
4,991,234	A	2/1991	Greenberg	5,681,285	A	10/1997	Ford et al.
4,996,975	A	3/1991	Nakamura	5,683,434	A	11/1997	Archer
5,005,374	A	4/1991	Spitler et al.	5,697,363	A	12/1997	Hart
5,054,488	A	10/1991	Muz	5,697,367	A	12/1997	Lewis et al.
5,080,096	A	1/1992	Hooper et al.	5,701,894	A	12/1997	Cherry et al.
5,080,098	A	1/1992	Willett et al.	5,706,820	A	1/1998	Hossack et al.
H1039	H	4/1992	Tripp, Jr. et al.	5,732,475	A	3/1998	Sacks et al.
5,111,817	A	5/1992	Clark et al.	5,738,612	A	4/1998	Tsuda
5,119,815	A	6/1992	Chance	5,743,856	A	4/1998	Oka et al.
5,122,974	A	6/1992	Chance	5,743,857	A	4/1998	Shinoda et al.
5,125,403	A	6/1992	Culp	5,752,913	A	5/1998	Oka
5,167,230	A	12/1992	Chance	5,752,920	A	5/1998	Ogura et al.
5,188,108	A	2/1993	Secker	5,758,644	A	6/1998	Diab et al.
5,191,891	A	3/1993	Righter	5,772,601	A	6/1998	Oka et al.
5,209,230	A	5/1993	Swedlow et al.	5,776,058	A	7/1998	Levinson et al.
5,214,409	A	5/1993	Beigel	5,776,071	A	7/1998	Inukai et al.
5,217,012	A	6/1993	Young et al.	5,779,631	A	7/1998	Chance
5,217,013	A	6/1993	Lewis et al.	5,779,639	A	7/1998	Yeung
5,241,300	A	8/1993	Buschmann	5,782,757	A	7/1998	Diab et al.
5,246,003	A	9/1993	DeLonzor	5,786,592	A	7/1998	Hök
5,253,645	A	10/1993	Friedman et al.	5,791,347	A	8/1998	Flaherty et al.
5,267,563	A	12/1993	Swedlow et al.	5,791,348	A	8/1998	Aung et al.
5,267,567	A	12/1993	Aung et al.	5,792,052	A	8/1998	Isaacson et al.
5,295,490	A	3/1994	Dodakian	5,792,058	A	8/1998	Lee et al.
5,313,940	A	5/1994	Fuse et al.	5,797,841	A	8/1998	DeLonzor et al.
5,337,744	A	8/1994	Brianigan	5,810,724	A	9/1998	Gronvall
5,348,008	A	9/1994	Born et al.	5,813,980	A	9/1998	Levinson et al.
5,353,798	A	10/1994	Sieben	5,817,008	A	10/1998	Rafert et al.
5,354,979	A	10/1994	Adelson et al.	5,823,012	A	10/1998	Hacskeylo
5,357,953	A	10/1994	Merrick et al.	5,823,952	A	10/1998	Levinson et al.
5,368,025	A	11/1994	Young et al.	5,826,277	A	10/1998	McConville
5,368,562	A	11/1994	Blomquist et al.	5,830,136	A	11/1998	DeLonzor et al.
5,369,808	A	12/1994	Brewer et al. 2/181.4	5,830,137	A	11/1998	Scharf
5,383,874	A	1/1995	Jackson et al.	5,830,148	A	11/1998	Inukai et al.
5,392,777	A	2/1995	Swedlow et al.	5,830,149	A	11/1998	Oka et al.
5,398,689	A	3/1995	Conner et al.	5,833,602	A	11/1998	Osemwota
5,400,267	A	3/1995	Denen et al.	5,836,887	A	11/1998	Oka et al.
5,405,269	A	4/1995	Stupecky	5,839,439	A	11/1998	Nierlich et al.
5,405,614	A	4/1995	D' Angelo et al.	RE36,000	E	12/1998	Swedlow et al.
5,413,099	A	5/1995	Schmidt et al.	5,842,981	A	12/1998	Larsen et al.
5,413,101	A	5/1995	Sugiura	5,842,982	A	12/1998	Mannheimer
5,413,102	A	5/1995	Schmidt et al.	5,851,179	A	12/1998	Ritson et al.
5,415,166	A	5/1995	Imran	5,853,364	A	12/1998	Baker, Jr. et al.
5,425,360	A	6/1995	Nelson	5,857,974	A	1/1999	Eberle et al.
5,431,170	A	7/1995	Mathews	5,860,932	A	1/1999	Goto et al.
5,437,275	A	8/1995	Amundsen et al.	5,860,957	A	1/1999	Jacobsen et al.
5,437,634	A	8/1995	Amano	5,868,133	A	2/1999	DeVries et al.
5,444,254	A	8/1995	Thomson	5,870,626	A	2/1999	Lebeau
5,451,763	A	9/1995	Pickett et al.	5,872,713	A	2/1999	Douglas et al.
5,452,717	A	9/1995	Branigan et al.	5,873,821	A	2/1999	Chance et al.
5,465,714	A	11/1995	Scheuing	5,879,294	A	3/1999	Anderson et al.
5,469,845	A	11/1995	DeLonzor et al.	5,891,021	A	4/1999	Dillon et al.
5,482,034	A	1/1996	Lewis et al.	5,891,026	A	4/1999	Wang et al.
5,490,523	A	2/1996	Isaacson et al.	5,895,359	A	4/1999	Peel
5,507,752	A	4/1996	Elliott	5,902,235	A	5/1999	Lewis et al.
5,528,519	A	6/1996	Ohkura et al.	5,906,581	A	5/1999	Tsuda
5,546,955	A	8/1996	Wilk	5,913,819	A	6/1999	Taylor et al.
				5,916,154	A	6/1999	Hobbs et al.

5,919,133	A	7/1999	Taylor et al.	6,343,223	B1	1/2002	Chin et al.
5,931,789	A	8/1999	Alfano et al.	6,343,224	B1	1/2002	Parker
5,931,790	A	8/1999	Peel	6,346,886	B1	2/2002	De La Huerga
5,931,791	A	8/1999	Saltzstein et al.	6,349,228	B1	2/2002	Kiani et al.
5,934,925	A	8/1999	Tobler et al.	6,356,774	B1	3/2002	Bernstein et al.
5,936,539	A	8/1999	Fuchs	6,362,622	B1	3/2002	Stauber et al.
5,947,905	A	9/1999	Hadjicostis et al.	6,368,282	B1	4/2002	Oka et al.
5,954,053	A	9/1999	Chance et al.	6,370,411	B1	4/2002	Osadchy et al.
5,957,850	A	9/1999	Marian, Jr. et al.	6,377,829	B1	4/2002	Al-Ali
5,964,701	A	10/1999	Asada et al.	6,381,480	B1	4/2002	Kuroyama Yukio
5,980,464	A	11/1999	Tsuda	6,381,481	B1	4/2002	Levendowski et al.
5,983,129	A	11/1999	Cowan et al.	6,385,486	B1	5/2002	John et al.
5,987,343	A	11/1999	Kinast	6,385,821	B1	5/2002	Modgil et al.
5,987,351	A	11/1999	Chance	6,387,092	B1	5/2002	Burnside et al.
5,991,648	A	11/1999	Levin	6,388,240	B2	5/2002	Schulz et al.
5,995,077	A	11/1999	Wilcox et al.	6,397,091	B2	5/2002	Diab et al.
5,995,855	A	11/1999	Kiani et al.	6,405,075	B1	6/2002	Levin
5,995,856	A	11/1999	Mannheimer et al.	6,416,471	B1	7/2002	Kumar et al.
5,995,857	A	11/1999	Toomim et al.	6,416,474	B1	7/2002	Penner et al.
6,007,492	A	12/1999	Goto et al.	6,417,774	B1	7/2002	Hibbs et al.
6,011,986	A	1/2000	Diab et al.	6,423,010	B1	7/2002	Friedman et al.
6,022,320	A	2/2000	Ogura et al.	6,430,423	B2	8/2002	DeLonzor et al.
6,027,453	A	2/2000	Miwa et al.	6,432,050	B1	8/2002	Porat et al.
6,030,351	A	2/2000	Schmidt et al.	6,450,168	B1	9/2002	Nguyen
6,031,603	A	2/2000	Fine et al.	6,450,957	B1	9/2002	Yoshimi et al.
6,036,651	A	3/2000	Inukai et al.	6,450,981	B1	9/2002	Shabty et al.
6,041,247	A	3/2000	Weckstrom et al.	6,454,708	B1	9/2002	Ferguson et al.
6,047,201	A	4/2000	Jackson	6,456,862	B2	9/2002	Benni
6,047,203	A	4/2000	Sackner et al.	6,461,305	B1	10/2002	Schnall
6,049,958	A	4/2000	Eberle et al.	6,463,310	B1	10/2002	Swedlow et al.
6,050,951	A	4/2000	Friedman et al.	6,466,809	B1	10/2002	Riley
6,052,619	A	4/2000	John	6,468,241	B1	10/2002	Gelfand et al.
6,073,038	A	6/2000	Wang et al.	6,470,199	B1	10/2002	Kopotic et al.
6,084,380	A	7/2000	Burton	6,470,279	B1	10/2002	Samsouandar
6,085,752	A	7/2000	Kehr et al.	6,480,762	B1	11/2002	Uchikubo et al.
6,088,607	A	7/2000	Diab et al.	6,491,638	B2	12/2002	Oka
6,106,780	A	8/2000	Douglas et al.	6,491,639	B1	12/2002	Turcott
6,112,107	A	8/2000	Hannula	6,503,087	B1	1/2003	Eggert et al.
6,115,621	A	9/2000	Chin	6,503,204	B1	1/2003	Sumanaweera et al.
6,118,382	A	9/2000	Hibbs et al.	6,505,061	B2	1/2003	Larson
6,134,459	A	10/2000	Roberts et al.	6,511,478	B1	1/2003	Burnside et al.
6,144,868	A	11/2000	Parker	6,516,289	B2	2/2003	David
6,149,481	A	11/2000	Wang et al.	6,519,487	B1	2/2003	Parker
6,152,754	A	11/2000	Gerhardt et al.	6,524,257	B2	2/2003	Ogura
6,154,667	A	11/2000	Miura et al.	6,525,386	B1	2/2003	Mills et al.
6,162,188	A	12/2000	Barnea	6,526,309	B1	2/2003	Chance
6,165,173	A	12/2000	Kamdar et al.	6,526,970	B2	3/2003	DeVries et al.
6,171,258	B1	1/2001	Karakasoglu et al.	6,527,725	B1	3/2003	Inuaki et al.
6,173,196	B1	1/2001	Delonzor et al.	6,527,726	B2	3/2003	Goto et al.
6,179,786	B1	1/2001	Young	6,535,765	B1	3/2003	Amely-Velez et al.
6,181,959	B1	1/2001	Schollermann et al.	6,537,220	B1	3/2003	Friemel et al.
6,184,521	B1	2/2001	Coffin, IV et al.	6,541,756	B2	4/2003	Schulz et al.
6,186,953	B1	2/2001	Narimatsu	6,542,081	B2	4/2003	Torch
6,186,954	B1	2/2001	Narimatsu	6,547,742	B2	4/2003	Oka et al.
6,190,325	B1	2/2001	Narimatsu	6,547,743	B2	4/2003	Brydon
6,196,974	B1	3/2001	Miwa	6,551,252	B2	4/2003	Sackner et al.
6,198,952	B1	3/2001	Miesel	6,553,242	B1	4/2003	Sarussi
6,199,550	B1	3/2001	Wiesmann et al.	6,575,902	B1	6/2003	Burton
6,209,144	B1	4/2001	Carter	6,575,904	B2	6/2003	Nagai et al.
6,216,021	B1	4/2001	Franceschini et al.	6,577,884	B1	6/2003	Boas
6,223,063	B1	4/2001	Chaiken et al.	6,580,086	B1	6/2003	Schulz et al.
6,241,680	B1	6/2001	Miwa	6,582,371	B2	6/2003	Miller
6,248,083	B1	6/2001	Smith et al.	6,582,374	B2	6/2003	Yokozeke
6,251,076	B1	6/2001	Hovland et al.	6,584,356	B2	6/2003	Wassmund et al.
6,251,080	B1	6/2001	Henkin et al.	6,589,171	B2	7/2003	Keirsbilck
6,251,081	B1	6/2001	Narimatsu	6,589,183	B2	7/2003	Yokozeke
6,251,113	B1	6/2001	Appelbaum et al.	6,589,189	B2	7/2003	Meyerson et al.
6,256,523	B1	7/2001	Diab et al.	6,594,513	B1	7/2003	Jobsis et al.
6,256,524	B1	7/2001	Walker et al.	6,597,933	B2	7/2003	Kiani et al.
6,263,221	B1	7/2001	Chance et al.	6,605,038	B1	8/2003	Teller et al.
6,263,223	B1	7/2001	Shepherd et al.	6,606,993	B1	8/2003	Wiesmann et al.
6,280,213	B1	8/2001	Tobler et al.	6,611,793	B1	8/2003	Burnside et al.
6,282,450	B1	8/2001	Hartlaub et al.	6,615,065	B1	9/2003	Barrett et al.
6,283,922	B1	9/2001	Goto et al.	6,622,034	B1	9/2003	Gorski et al.
6,285,895	B1	9/2001	Ristolainen et al.	6,626,537	B1	9/2003	Odom et al.
6,306,076	B1	10/2001	Gill	6,635,048	B1	10/2003	Ullestad et al.
6,308,089	B1	10/2001	von der Ruhr et al.	6,640,116	B2	10/2003	Diab
6,321,100	B1	11/2001	Parker	6,645,154	B2	11/2003	Oka
6,322,516	B1	11/2001	Masuda et al.	6,645,155	B2	11/2003	Inuaki et al.

6,653,557	B2	11/2003	Wolf et al.	6,952,870	B2	10/2005	Miller
6,654,622	B1	11/2003	Eberhard et al.	6,955,650	B2	10/2005	Mault et al.
6,662,033	B2	12/2003	Casciani et al.	6,965,071	B2	11/2005	Watchko et al.
6,666,860	B1	12/2003	Takahashi	6,971,790	B2	12/2005	Quinn et al.
6,671,531	B2	12/2003	Al-Ali et al.	6,979,329	B2	12/2005	Burnside et al.
6,671,545	B2	12/2003	Fincke	6,985,763	B2	1/2006	Boas et al.
6,678,543	B2	1/2004	Diab et al.	6,985,764	B2	1/2006	Mason et al.
6,681,454	B2	1/2004	Modgil et al.	6,990,371	B2	1/2006	Powers et al.
6,684,091	B2	1/2004	Parker	6,993,371	B2	1/2006	Kiani et al.
6,694,160	B2	2/2004	Chin	6,995,665	B2	2/2006	Appelt et al.
6,695,806	B2	2/2004	Gelfand et al.	7,001,334	B2	2/2006	Reed et al.
6,700,497	B2	3/2004	Hibbs et al.	7,017,420	B2	3/2006	Kalvesten et al.
6,704,601	B1	3/2004	Amely-Velez et al.	7,018,338	B2	3/2006	Vetter et al.
6,708,048	B1	3/2004	Chance	7,019,392	B2	3/2006	Iwaskai
6,711,425	B1	3/2004	Reuss	7,020,508	B2	3/2006	Stivoric et al.
6,712,767	B2	3/2004	Hossack et al.	7,024,235	B2	4/2006	Melker et al.
6,721,585	B1	4/2004	Parker	7,027,850	B2	4/2006	Wasserman
6,721,602	B2	4/2004	Engmark et al.	7,027,871	B2	4/2006	Burnes et al.
6,725,075	B2	4/2004	Al-Ali	7,033,316	B2	4/2006	Takahashi
6,726,327	B2	4/2004	Torrey et al.	7,039,449	B2	5/2006	Al-Ali
6,731,963	B2	5/2004	Finarov et al.	7,041,121	B1	5/2006	Williams et al.
6,735,459	B2	5/2004	Parker	7,047,054	B2	5/2006	Benni
6,736,759	B1	5/2004	Stubbs et al.	7,047,055	B2	5/2006	Boas et al.
6,736,786	B1	5/2004	Shabty et al.	7,047,056	B2	5/2006	Hannula et al.
6,743,173	B2	6/2004	Penner et al.	7,048,687	B1	5/2006	Reuss et al.
6,743,202	B2	6/2004	Hirschman et al.	7,052,509	B2	5/2006	Lennox
6,745,061	B1	6/2004	Hicks et al.	7,054,453	B2	5/2006	Causevic et al.
6,748,254	B2	6/2004	O'Neil et al.	7,054,454	B2	5/2006	Causevic et al.
6,748,262	B2	6/2004	Harada et al.	7,063,669	B2	6/2006	Brawner et al.
6,749,567	B2	6/2004	Davis	7,067,893	B2	6/2006	Mills et al.
6,755,789	B2	6/2004	Stringer et al.	7,072,704	B2	7/2006	Bucholz
6,758,808	B2	7/2004	Paul	7,079,036	B2	7/2006	Cooper et al.
6,763,255	B2	7/2004	DeLonzor et al.	7,081,128	B2	7/2006	Hart et al.
6,767,330	B2	7/2004	Lavery	7,085,597	B2	8/2006	Fein et al.
6,771,994	B2	8/2004	Kiani et al.	7,107,706	B1	9/2006	Bailey
6,776,758	B2	8/2004	Peszynski et al.	7,113,815	B2	9/2006	O'Neil et al.
6,779,257	B2	8/2004	Kiepen et al.	7,132,641	B2	11/2006	Schulz et al.
6,785,568	B2	8/2004	Chance	7,171,251	B2	1/2007	Sarussi et al.
6,792,300	B1	9/2004	Diab et al.	7,181,264	B2	2/2007	Wiesmann et al.
6,796,946	B2	9/2004	Ogura et al.	7,204,250	B1	4/2007	Burton
6,801,799	B2	10/2004	Mendelson	7,220,220	B2	5/2007	Stubbs et al.
6,804,543	B2	10/2004	Miller et al.	7,245,953	B1	7/2007	Parker
6,804,558	B2	10/2004	Haller et al.	7,248,910	B2	7/2007	Li et al.
6,808,496	B2	10/2004	Oka et al.	7,289,837	B2	10/2007	Mannheimer et al.
6,811,538	B2	11/2004	Westbrook et al.	7,297,119	B2	11/2007	Westbrook et al.
6,813,511	B2	11/2004	Diab et al.	7,313,427	B2	12/2007	Benni
6,824,520	B2	11/2004	Orr et al.	7,349,726	B2	3/2008	Casciani et al.
6,827,688	B2	12/2004	Goto et al.	7,376,454	B2	5/2008	Casciani et al.
6,829,003	B2	12/2004	Takami	7,413,305	B2	8/2008	Baumann et al.
6,830,711	B2	12/2004	Mills et al.	7,415,298	B2	8/2008	Casciani et al.
6,832,987	B2	12/2004	David et al.	7,698,909	B2	4/2010	Hannula et al.
6,842,722	B2	1/2005	David	2001/0000790	A1	5/2001	DeLonzor et al.
6,847,294	B1	1/2005	Lin et al.	2001/0009398	A1	7/2001	Sekura et al.
6,849,074	B2	2/2005	Chen et al.	2002/0013538	A1	1/2002	Teller
6,853,304	B2	2/2005	Reisman et al.	2002/0042558	A1	4/2002	Mendelson
6,870,479	B2	3/2005	Gabriel	2002/0052539	A1	5/2002	Haller et al.
6,875,176	B2	4/2005	Mourad et al.	2002/0084904	A1	7/2002	De La Huerga
6,877,511	B2	4/2005	DeVries et al.	2002/0091335	A1	7/2002	John et al.
6,893,400	B2	5/2005	Kawaguchi et al.	2002/0095087	A1	7/2002	Mourad et al.
6,898,299	B1	5/2005	Brooks	2002/0095092	A1	7/2002	Kondo et al.
6,899,682	B2	5/2005	Eberle et al.	2002/0103445	A1	8/2002	Rahdert et al.
6,899,684	B2	5/2005	Mault et al.	2002/0109600	A1	8/2002	Mault et al.
6,904,124	B2	6/2005	Staver et al.	2002/0124295	A1	9/2002	Fenwick et al.
6,907,284	B2	6/2005	Hamilton et al.	2002/0135488	A1	9/2002	Hibbs et al.
6,909,912	B2	6/2005	Melker	2002/0139368	A1	10/2002	Bachinski
6,911,027	B1	6/2005	Edwards et al.	2002/0148470	A1	10/2002	Blue et al.
6,915,167	B2	7/2005	Splett et al.	2002/0151929	A1	10/2002	Goto et al.
6,920,345	B2	7/2005	Al-Ali et al.	2002/0156354	A1	10/2002	Larson
6,921,198	B2	7/2005	Gruszecki et al.	2002/0161290	A1	10/2002	Chance
6,923,771	B2	8/2005	Ogura et al.	2002/0161309	A1	10/2002	Marro
6,923,776	B2	8/2005	Shabty et al.	2002/0165462	A1	11/2002	Westbrook et al.
6,930,608	B2	8/2005	Grajales et al.	2002/0173706	A1	11/2002	Takatani et al.
6,934,570	B2	8/2005	Kiani et al.	2002/0173708	A1	11/2002	DeLonzor et al.
6,934,571	B2	8/2005	Wiesmann et al.	2003/0004547	A1	1/2003	Owens et al.
6,936,011	B2	8/2005	Sheldon	2003/0009119	A1	1/2003	Kamm et al.
6,938,488	B2	9/2005	Diaz et al.	2003/0009308	A1	1/2003	Kirtley
6,939,314	B2	9/2005	Hall et al.	2003/0018243	A1	1/2003	Gerhardt et al.
6,943,881	B2	9/2005	Wang	2003/0023140	A1	1/2003	Chance
6,944,498	B2	9/2005	Owens et al.	2003/0036685	A1	2/2003	Goodman

2003/0062046	A1	4/2003	Wiesmann et al.	2005/0197548	A1	9/2005	Dietiker
2003/0065273	A1	4/2003	Mault et al.	2005/0206518	A1	9/2005	Welch et al.
2003/0065274	A1	4/2003	Mault et al.	2005/0215847	A1	9/2005	Heruth et al.
2003/0065275	A1	4/2003	Mault et al.	2005/0215880	A1	9/2005	Harrison et al.
2003/0086156	A1	5/2003	McGuire	2005/0215947	A1	9/2005	Heruth et al.
2003/0109775	A1	6/2003	O'Neil et al.	2005/0216064	A1	9/2005	Heruth et al.
2003/0120183	A1	6/2003	Simmons	2005/0216199	A1	9/2005	Banet
2003/0122706	A1	7/2003	Choi et al.	2005/0222522	A1	10/2005	Heruth et al.
2003/0125616	A1	7/2003	Black et al.	2005/0222643	A1	10/2005	Heruth et al.
2003/0135127	A1	7/2003	Sackner et al.	2005/0228234	A1	10/2005	Yang
2003/0144579	A1	7/2003	Buss	2005/0228297	A1	10/2005	Banet et al.
2003/0156288	A1	8/2003	Barnum et al.	2005/0231686	A1	10/2005	Rathjen
2003/0176810	A1	9/2003	Maahs et al.	2005/0234312	A1	10/2005	Suzuki et al.
2003/0189492	A1	10/2003	Harvie	2005/0234317	A1	10/2005	Kiani
2003/0214408	A1	11/2003	Grajales et al.	2005/0234518	A1	10/2005	Heruth et al.
2003/0216728	A1	11/2003	Stern et al.	2005/0240087	A1	10/2005	Keenan et al.
2003/0225323	A1	12/2003	Kiani et al.	2005/0256523	A1	11/2005	Chen et al.
2003/0229276	A1	12/2003	Sarussi et al.	2005/0261594	A1	11/2005	Banet
2004/0002655	A1	1/2004	Bolorforosh et al.	2005/0268916	A1	12/2005	Mumford et al.
2004/0004547	A1	1/2004	Appelt et al.	2005/0277819	A1	12/2005	Kiani et al.
2004/0007585	A1	1/2004	Griffith et al.	2005/0277821	A1	12/2005	Payne, Jr.
2004/0030258	A1	2/2004	Williams et al.	2005/0283082	A1	12/2005	Geddes et al.
2004/0044545	A1	3/2004	Wiesmann et al.	2006/0009685	A1	1/2006	Finarov et al.
2004/0054287	A1	3/2004	Stephens	2006/0009698	A1	1/2006	Banet et al.
2004/0054291	A1	3/2004	Schulz et al.	2006/0020181	A1	1/2006	Schmidt
2004/0059212	A1*	3/2004	Abreu 600/373	2006/0030049	A1	2/2006	Bhimani et al.
2004/0064097	A1	4/2004	Peterson	2006/0030767	A1	2/2006	Lang et al.
2004/0064165	A1	4/2004	Thompson	2006/0036179	A1	2/2006	Miller
2004/0082842	A1	4/2004	Lumba et al.	2006/0047447	A1	3/2006	Brady et al.
2004/0092919	A1	5/2004	Ritchie et al.	2006/0058593	A1	3/2006	Drinan et al.
2004/0100784	A1	5/2004	Willers et al.	2006/0058690	A1	3/2006	Bartnik et al.
2004/0102931	A1	5/2004	Ellis et al.	2006/0064133	A1	3/2006	Von Arx et al.
2004/0117891	A1	6/2004	Hannula et al.	2006/0064134	A1	3/2006	Mazar et al.
2004/0122302	A1	6/2004	Mason et al.	2006/0064142	A1	3/2006	Chavan et al.
2004/0144391	A1	7/2004	Brady et al.	2006/0064143	A1	3/2006	Von Arx et al.
2004/0147974	A1	7/2004	Engmark et al.	2006/0074283	A1	4/2006	Henderson et al.
2004/0149282	A1	8/2004	Hickle	2006/0074324	A1	4/2006	Wu et al.
2004/0163648	A1	8/2004	Burton	2006/0084848	A1	4/2006	Mitchnick
2004/0173456	A1	9/2004	Boos et al.	2006/0084852	A1	4/2006	Mason et al.
2004/0186390	A1	9/2004	Ross et al.	2006/0085227	A1	4/2006	Rosenfeld et al.
2004/0221370	A1	11/2004	Hannula et al.	2006/0095032	A1	5/2006	Jackson et al.
2004/0230116	A1	11/2004	Cowan et al.	2006/0100496	A1	5/2006	Avron
2004/0231772	A1	11/2004	Leonard et al.	2006/0100530	A1	5/2006	Kliot et al.
2004/0236207	A1	11/2004	Widener et al.	2006/0100618	A1	5/2006	Chan et al.
2004/0236242	A1	11/2004	Graham et al.	2006/0122517	A1	6/2006	Banet et al.
2004/0242981	A1	12/2004	Pattisapu	2006/0122520	A1	6/2006	Banet et al.
2004/0254490	A1	12/2004	Egli	2006/0124128	A1	6/2006	Deane et al.
2004/0254501	A1	12/2004	Mault	2006/0125623	A1	6/2006	Applet et al.
2004/0260191	A1	12/2004	Stubbs et al.	2006/0132382	A1	6/2006	Jannard
2004/0263337	A1	12/2004	Terauchi et al.	2006/0133362	A1	6/2006	Stein et al.
2004/0267104	A1	12/2004	Hannula et al.	2006/0142640	A1	6/2006	Takahashi
2004/0267145	A1	12/2004	David et al.	2006/0149132	A1	7/2006	Iddan
2005/0001728	A1	1/2005	Appelt et al.	2006/0149339	A1	7/2006	Burnes et al.
2005/0020919	A1	1/2005	Stringer et al.	2006/0167351	A1	7/2006	Isaacson et al.
2005/0027207	A1	2/2005	Westbrook et al.	2006/0195026	A1	8/2006	Casciani et al.
2005/0029432	A1	2/2005	Bacarella et al.	2006/0195027	A1	8/2006	Casciani et al.
2005/0041531	A1	2/2005	Sekura et al.	2006/0195028	A1	8/2006	Hannula et al.
2005/0043599	A1	2/2005	O'Mara	2006/0211929	A1	9/2006	Casciani et al.
2005/0043763	A1	2/2005	Marcovecchio et al.	2006/0217604	A1	9/2006	Fein et al.
2005/0049465	A1	3/2005	Wang	2006/0217605	A1	9/2006	Fein et al.
2005/0049501	A1	3/2005	Conero et al.	2006/0217606	A1	9/2006	Fein et al.
2005/0059869	A1	3/2005	Scharf et al.	2006/0217607	A1	9/2006	Fein et al.
2005/0070776	A1	3/2005	Mannheimer et al.	2006/0217608	A1	9/2006	Fein et al.
2005/0070778	A1	3/2005	Lakcey et al.	2006/0229510	A1	10/2006	Fein et al.
2005/0075550	A1	4/2005	Lindekugel	2006/0229511	A1	10/2006	Fein et al.
2005/0080345	A1	4/2005	Finburgh et al.	2006/0264722	A1	11/2006	Hannula et al.
2005/0085799	A1	4/2005	Luria et al.	2006/0264723	A1	11/2006	Hannula et al.
2005/0090754	A1	4/2005	Wolff et al.	2006/0264724	A1	11/2006	Hannula et al.
2005/0096557	A1	5/2005	Vosburgh et al.	2006/0264725	A1	11/2006	Hannula et al.
2005/0101845	A1	5/2005	Nihtila	2006/0264726	A1	11/2006	Mannheimer et al.
2005/0102167	A1	5/2005	Kapoor	2006/0276700	A1	12/2006	O'Neil et al.
2005/0113650	A1	5/2005	Pacione et al.	2006/0281984	A1	12/2006	Mannheimer et al.
2005/0113656	A1	5/2005	Chance	2007/0032732	A1	2/2007	Shelley et al.
2005/0113703	A1	5/2005	Farringdon et al.	2007/0149871	A1	6/2007	Sarussi et al.
2005/0114154	A1	5/2005	Wolkoweiz et al.	2007/0293746	A1	12/2007	Sarussi et al.
2005/0171576	A1	8/2005	Williams et al.	2008/0009691	A1	1/2008	Parker
2005/0182458	A1	8/2005	Goedeke	2008/0076988	A1	3/2008	Sarussi et al.
2005/0188991	A1	9/2005	Sun et al.	2008/0076990	A1	3/2008	Sarussi et al.
2005/0190068	A1	9/2005	Gentry et al.				

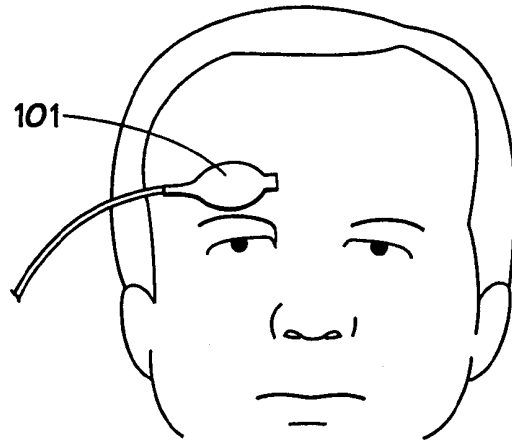

FIG. 1

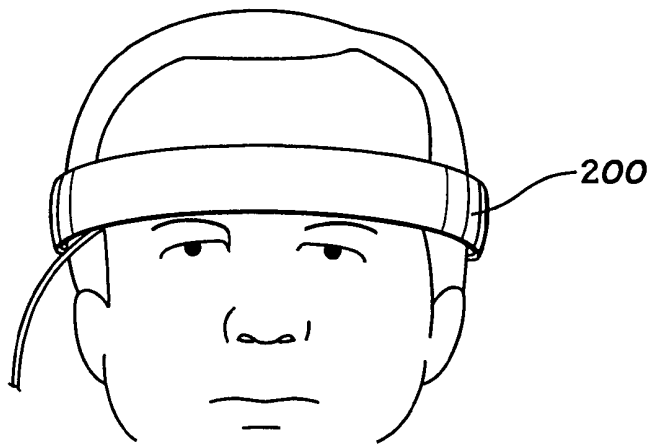

FIG. 2

FIG. 3A

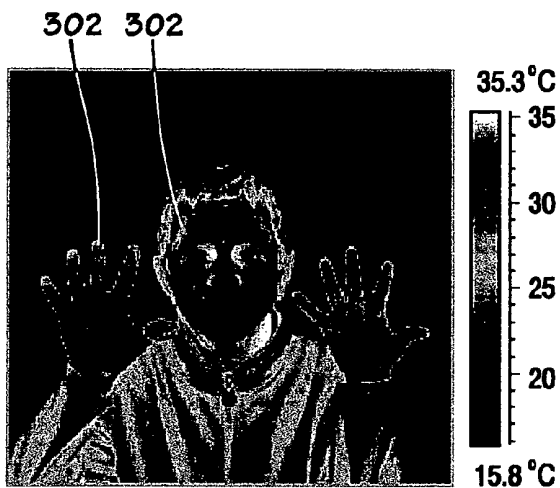

FIG. 3B

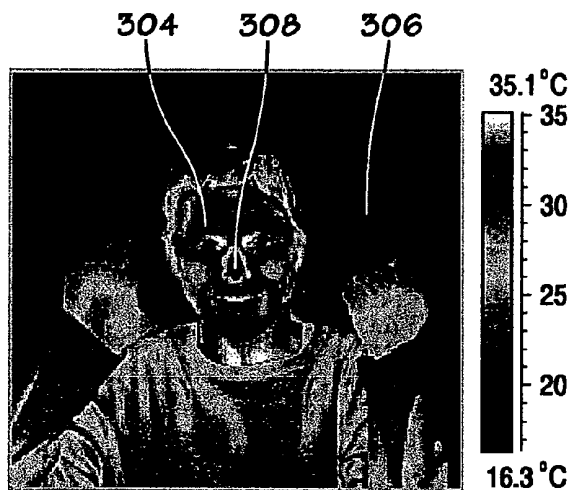

FIG. 3C

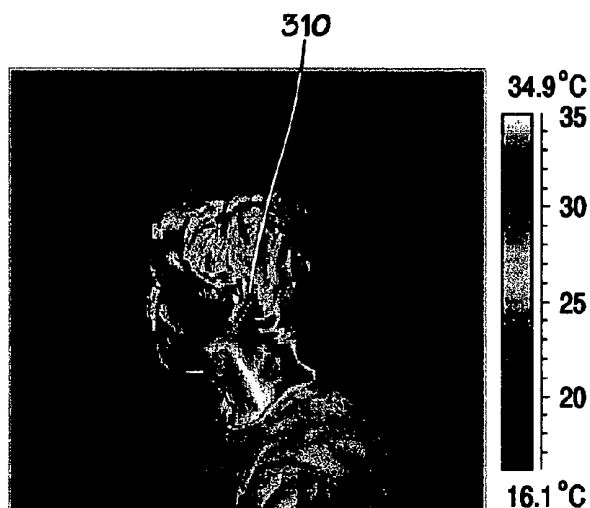

FIG. 4

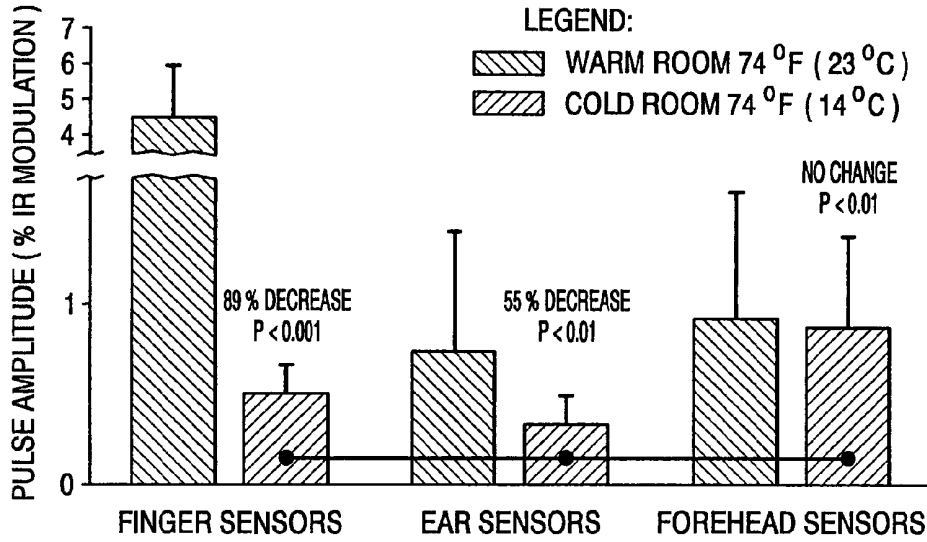
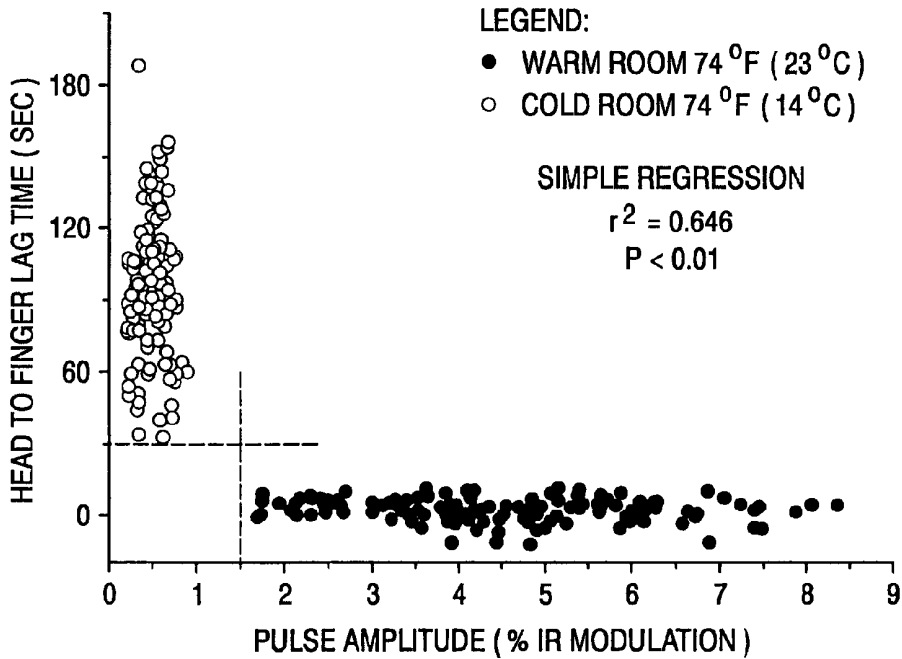
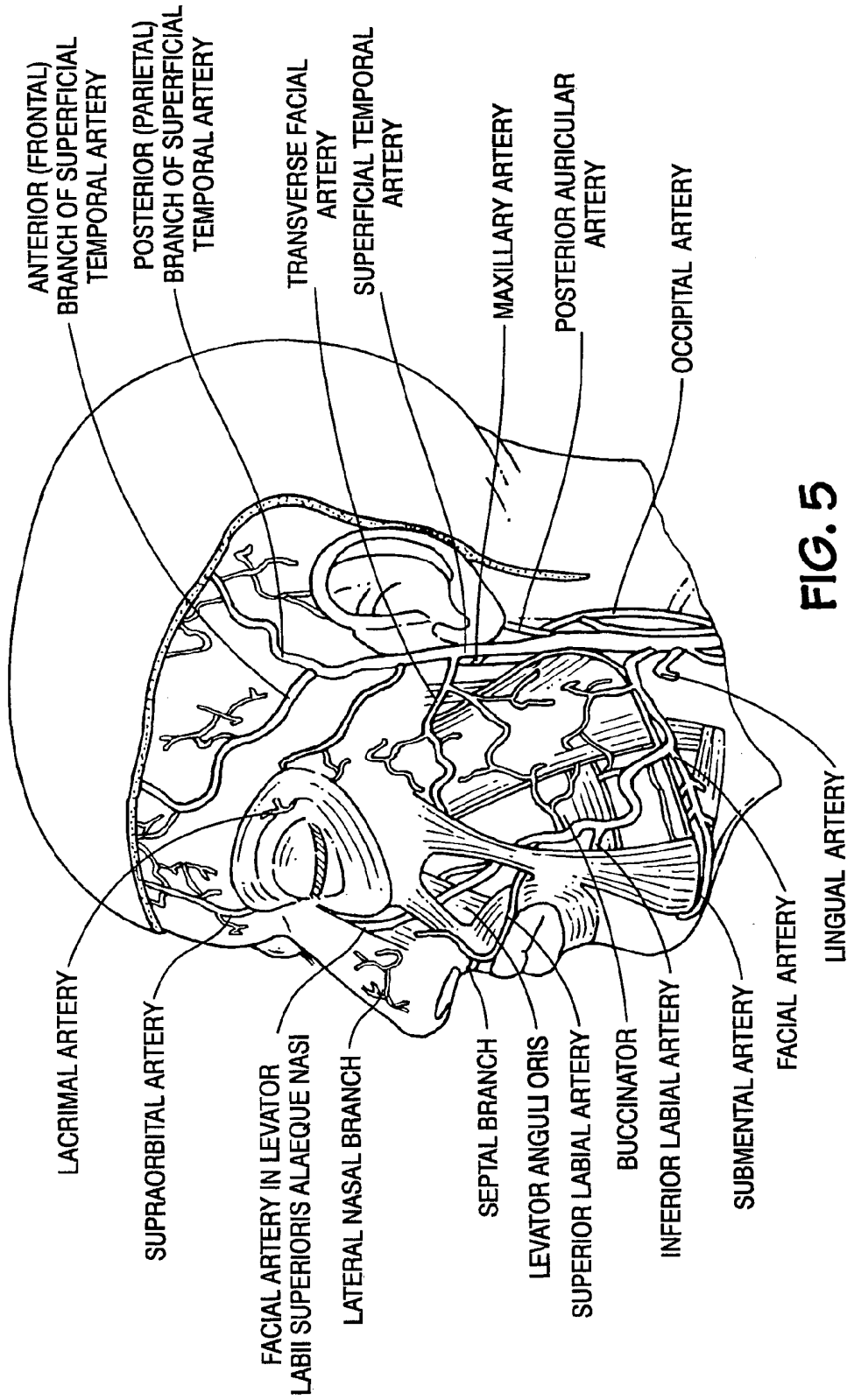

FIG. 10





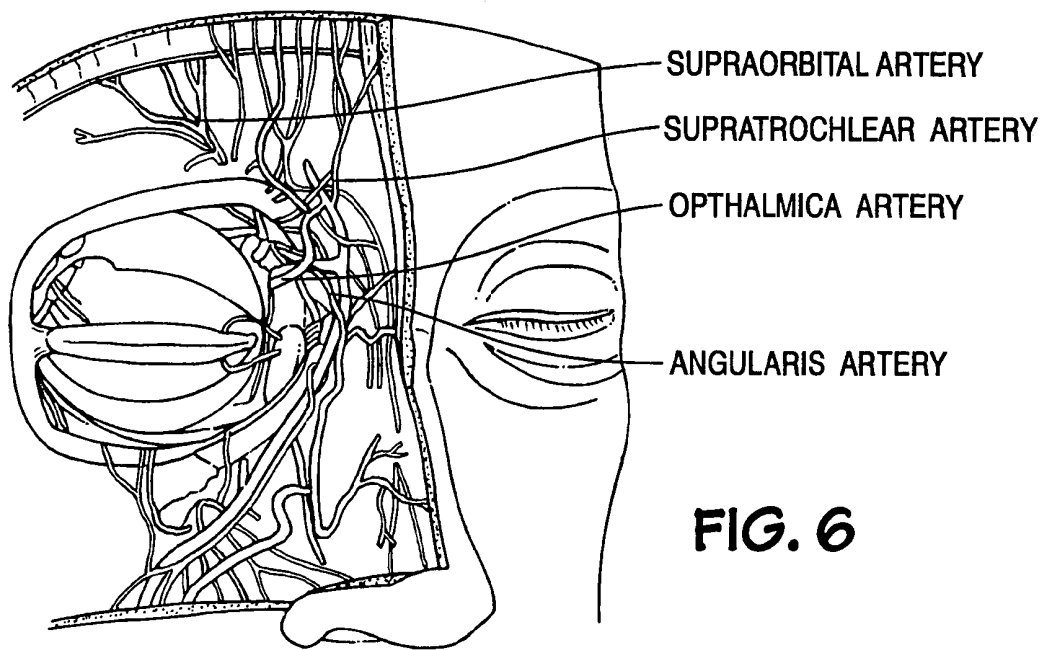

FIG. 6

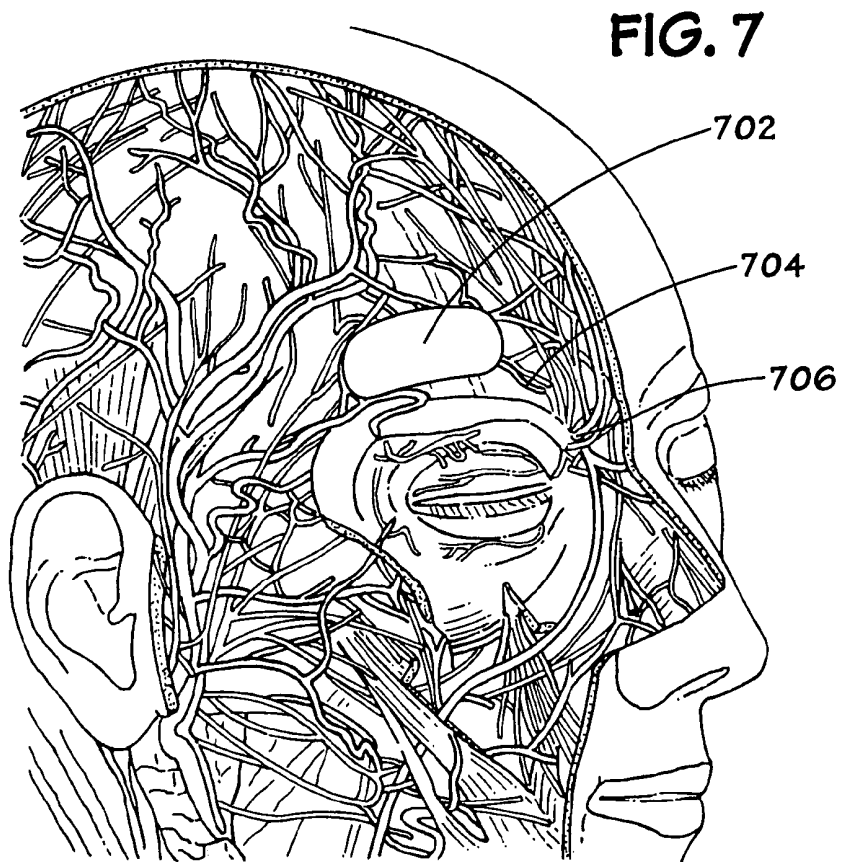



FIG. 8

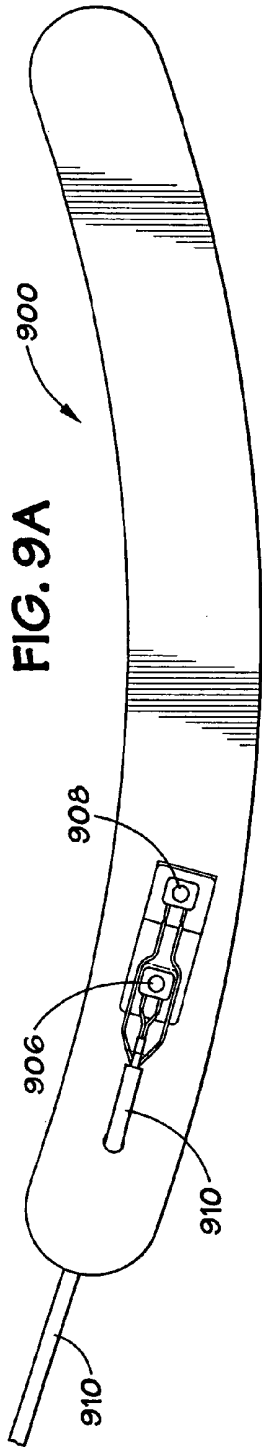

FIG. 9A

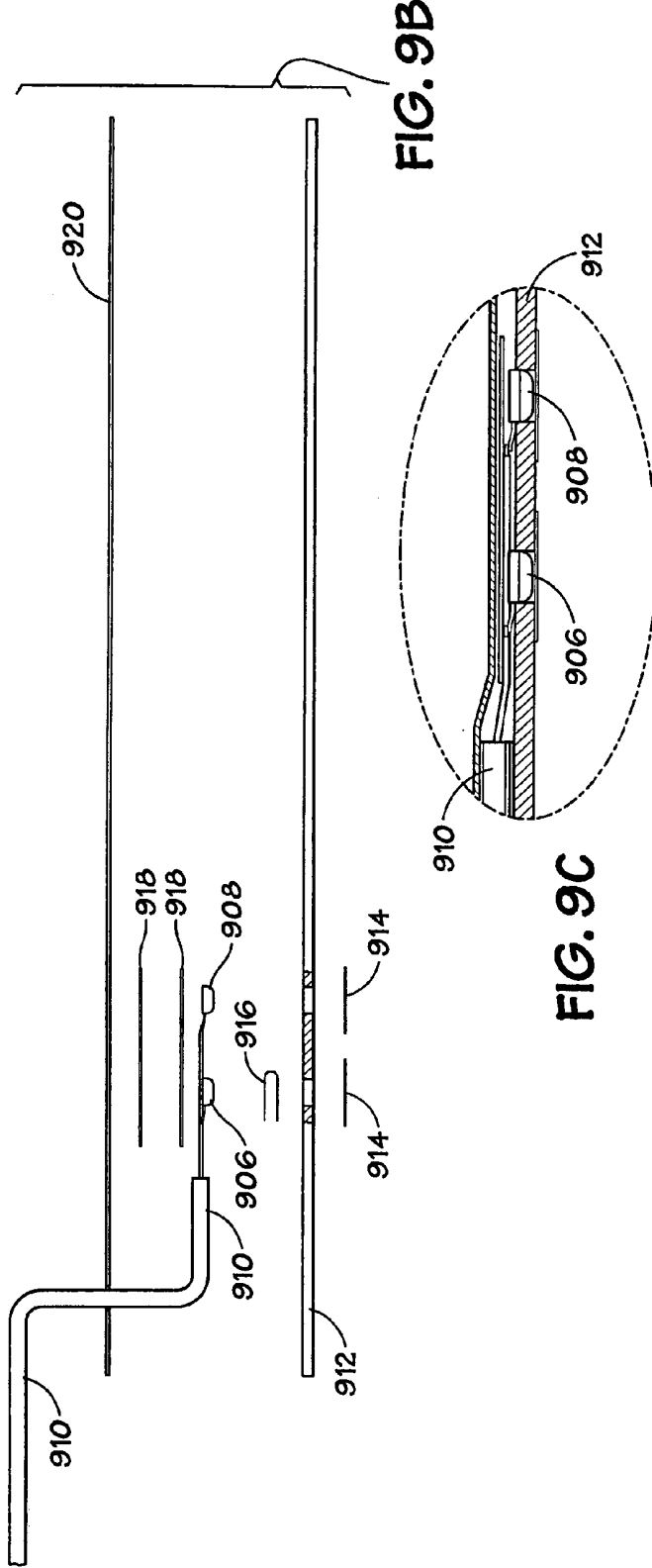
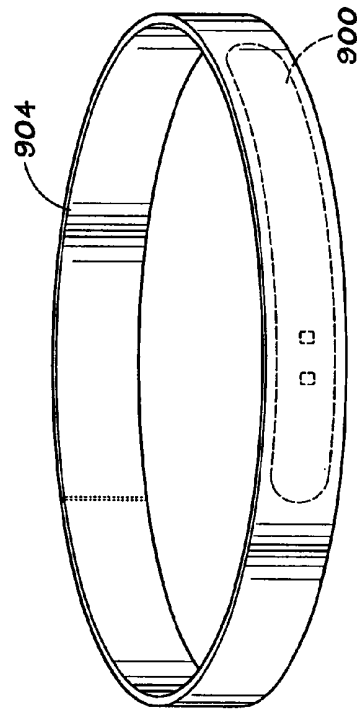
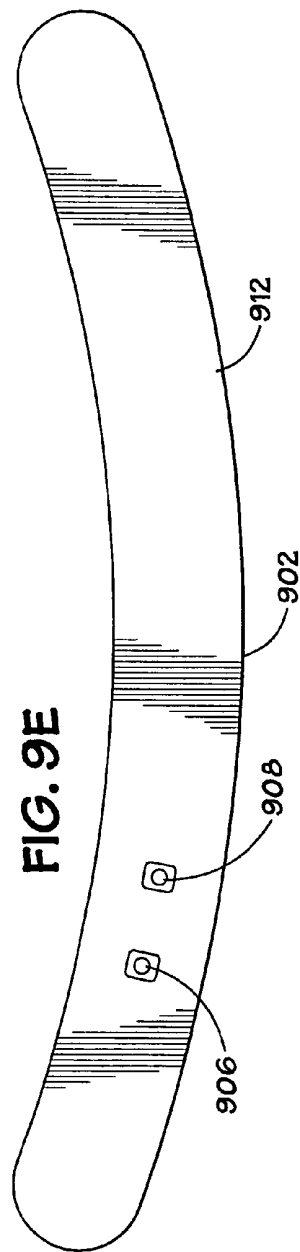
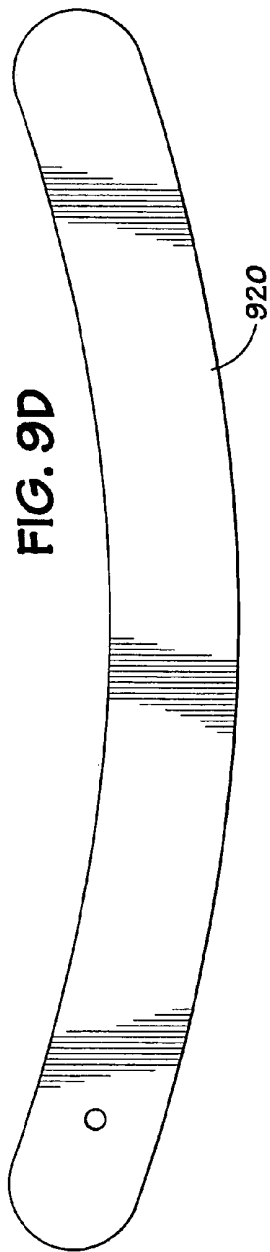

FIG. 9B

FIG. 9C



FOREHEAD SENSOR PLACEMENT**CROSS-REFERENCES TO RELATED APPLICATIONS**

This application is a continuation of prior U.S. patent application Ser. No. 11/495,195, filed Jul. 28, 2006, which is a division of prior U.S. patent application Ser. No. 10/678,040, filed Oct. 1, 2003, now U.S. Pat. No. 7,289,837, which claims the benefit of U.S. Provisional Patent Application Ser. No. 60/415,468, filed Oct. 1, 2002, which disclosures are incorporated by reference in their entirety for all purposes.

BACKGROUND OF THE INVENTION

The present invention relates to oximetry sensors and in particular to forehead-type oximetry sensors and methods of determining physiological parameters using forehead oximetry sensors.

It is known that the location on a patient's body where an oximetry sensor is applied can have an effect on the estimation of a physiological parameter that is determined using the sensor. It is also known that oximetry measurements can be obtained by placing an oximetry sensor on various locations on the body of a patient, including the fingertips, the earlobe, the foot, the head and so on. In order to have a proper sensor reading, there is a need for ensuring that the sensor is applied to an optimal location on a patient's body; a location where oximetry signals are stable and indicative of the actual physiological parameter which is being monitored.

BRIEF SUMMARY OF THE INVENTION

The present invention is directed towards forehead oximetry sensors and methods of determining physiological parameters using forehead oximetry sensors. In one embodiment, the present invention provides a method of determining a physiological parameter using a pulse oximeter. The method includes placing an oximetry sensor on the forehead of a patient, such that the sensor is placed on the lower forehead region, above the eyebrow with the sensor optics placed lateral of the iris and proximal the temple; and operating the pulse oximeter to obtain the physiological parameter. In one aspect, the method also includes providing and placing a headband over the oximetry sensor. The headband has an elastic segment sized to fit around the patient's head. The headband also includes a non-elastic segment that is smaller than and attached with the elastic segment. The non-elastic segment is sized to span a portion of the elastic segment when the elastic segment is stretched. In addition, the non-elastic segment is larger than the portion of the elastic segment it spans when the elastic segment is not stretched.

In another embodiment, the present invention provides a method for determining a location for the placement of an oximetry sensor. The method includes: measuring the temperature of a plurality of locations on an area of the body of a patient; dividing the temperature measurements into three categories including cold, warm and hot regions, wherein hot areas correspond with areas including those over large movable blood vessels and wherein cold areas correspond with areas including those susceptible to vasoconstriction; and selecting the area that is not hot and not cold as a location for the placement of the sensor.

In another embodiment, the present invention provides a method for determining a location for the placement of an oximetry sensor. The method includes: providing a pulse oximeter having a monitor and a sensor; placing the sensor on

a location on the body of a patient; measuring a pulse amplitude using the sensor; comparing the pulse amplitude to a threshold; and recommending a new sensor location using the monitor if the pulse amplitude is lower than the threshold.

5 In another embodiment, the present invention provides an oximeter sensor, having a substrate having a shape similar to a shape of at least a portion of a patient's forehead and including a section adapted to substantially fit over a portion of a forehead of a patient. The sensor includes an emitter disposed on the substrate at a position located on the section and a detector disposed on the substrate at a distance from the emitter; and a headband for holding the substrate against the patient's forehead, where the headband is sized to fit around the patient's head. In one aspect, the headband includes an elastic segment sized to fit around a patient's head; and a non-elastic segment that is smaller than and attached with the elastic segment. The non-elastic segment is sized to span a portion of the elastic segment when the elastic segment is stretched, and the non-elastic segment is larger than the portion of the elastic segment it spans when the elastic segment is not stretched. In another aspect, the headband's non-elastic segment is sized to not project out from the surface of the elastic portion when the headband is sufficiently tight, thus indicating an adequate level of tension corresponding with delivering a pressure in the range higher than the venous pressure and lower than the capillary pressure to the forehead of the patient.

For a further understanding of the nature and advantages of the invention, reference should be made to the following description taken in conjunction with the accompanying drawings.

BRIEF DESCRIPTION OF THE DRAWINGS

FIG. 1 is a diagram of a forehead oximetry sensor applied to a patient.

FIG. 2 is a diagram of a forehead oximetry sensor held to a patient's forehead with a headband.

FIGS. 3A-C are thermal images of a person's hands and head in a warm room and after cold room exposure for approximately 45 minutes.

FIG. 4 is a graph showing pulse amplitude signal variations due to a change in the environment's temperature obtained from various sensors located at various locations on a patient's body.

FIG. 5 is a diagram of the arteries in a human head.

FIG. 6 is a detailed diagram of the arteries around a human eye.

FIG. 7 is a diagram of the arteries in a human head and a preferred location for an oximetry sensor.

FIG. 8 is an infrared thermal image of a human head illustrating a proper sensor placement.

FIG. 9A-F is an assembly drawing of an embodiment of a headband-integrated sensor.

FIG. 10 is a graph of the relationship between Lag Time and Pulse Amplitude.

DETAILED DESCRIPTION OF THE INVENTION

The embodiments of the present invention are directed towards forehead oximetry sensors and methods of determining physiological parameters using forehead oximetry sensors. During oximetry, a forehead oximetry sensor 101 (e.g., such as those manufactured by Nellcor Puritan Bennett, the assignee herein), is placed on a patient's forehead, as is shown in FIG. 1. A typical pulse oximeter measures two physiological parameters, percent oxygen saturation of arterial blood

hemoglobin (SpO₂ or sat) and pulse rate. Oxygen saturation can be estimated using various techniques. In one common technique, the photocurrent generated by the photo-detector is conditioned and processed to determine the ratio of modulation ratios (ratio of ratios) of the red to infrared signals. This modulation ratio has been observed to correlate well to arterial oxygen saturation. The pulse oximeters and sensors are empirically calibrated by measuring the modulation ratio over a range of in vivo measured arterial oxygen saturations (SaO₂) on a set of patients, healthy volunteers, or animals. The observed correlation is used in an inverse manner to estimate blood oxygen saturation (SpO₂) based on the measured value of modulation ratios of a patient. The estimation of oxygen saturation using modulation ratios is described in U.S. Pat. No. 5,853,364, entitled "METHOD AND APPARATUS FOR ESTIMATING PHYSIOLOGICAL PARAMETERS USING MODEL-BASED ADAPTIVE FILTERING", issued Dec. 29, 1998, and U.S. Pat. No. 4,911,167, entitled "METHOD AND APPARATUS FOR DETECTING OPTICAL PULSES", issued Mar. 27, 1990, and the relationship between oxygen saturation and modulation ratio is further described in U.S. Pat. No. 5,645,059, entitled "MEDICAL SENSOR WITH MODULATED ENCODING SCHEME," issued Jul. 8, 1997, the disclosures of which are herein incorporated by reference in their entirety. Most pulse oximeters extract the plethysmographic signal having first determined saturation or pulse rate.

The force applied to the forehead oximetry sensor can be a factor in the proper functioning of the sensor. Generally, a headband is not required to be worn with a forehead oximetry sensor, when the patient's head is upright and/or well above the chest, and/or when the patient has normal venous pressure. In certain clinical scenarios, a headband **200** is required to be used in conjunction with a forehead sensor **101** (e.g., an oximetry sensor), as is shown in FIG. 2. FIG. 2 shows the sensor leads extending from the sensor (not shown) outward from beneath the headband. Such clinical scenarios include scenarios where: patient is lying down with his/her head near or below chest level; patient is subject to elevated venous pressure; patient is diaphoretic; patient is moving excessively, such as during exercise; as well as other scenarios where venous pulsations can introduce errors in oximetry calculations. In those scenarios, without a headband, or force on the oximetry sensor, venous pulsations could cause an incorrect interpretation of the waveform, and therefore result in a less than accurate determination of the oxygen saturation and pulse rate values. The headband can be used to apply pressure to the oximetry sensor, thus reducing the effects of venous pulsations. When used to support an oximetry sensor, the amount of force applied by the sensor on the forehead should be greater than the venous pressure, but less than the arteriole pressure. Generally, a good pressure range is one where the applied pressure is higher than venous pressure (e.g., 3-5 mm Hg) and lower than the capillary pressure (e.g., 22 mm Hg). Preferably, this should be between 15 mm Hg and 20 mm Hg in the adult patient. Exemplary headbands having a pressure or tension indicator are described in a co-pending U.S. patent application Ser. No. 11/495,195, entitled: "FOREHEAD SENSOR PLACEMENT," the disclosure of which is herein incorporated by reference in its entirety for all purposes. As set forth in that co-pending patent application, the headband may be adjusted for use with any size wearer by using an adjustable closure mechanism, such as for example a hook and loop closure mechanism. The user can apply a wide range of pressures to the forehead oximetry sensor depending on the amount of tension which has been applied to the headband during its placement around the wearer's head. In addition,

the tension or pressure indicating headband disclosed therein, may be used to help establish an acceptable window of pressure for the sensor's attachment with a patient. The headband when used with a forehead oximetry sensor assists in holding the sensor in place and applies a gentle pressure to expel any pulsating venous blood.

The inventors having conducted various physiological studies have determined that in addition to the possibility of needing to apply an oximetry sensor to the forehead of a patient with a certain amount of pressure, the actual location where the forehead oximetry sensor is applied is also a contributor to the ultimate estimation of physiological parameters determined using the forehead oximeter. An exemplary forehead oximetry sensor is described in a U.S. Pat. No. 6,748,254, entitled: "STACKED ADHESIVE OPTICAL SENSOR," the disclosure of which is herein incorporated by reference in its entirety for all purposes.

The physiological studies conducted by the inventors herein have not only lead to the discovery of preferred locations for the placement of a forehead oximetry sensor, but have also discovered why the forehead and in particular the lower forehead is a preferred sensor location.

FIGS. 3A-C are thermal images of a person's hands and head in a warm room and after cold room exposure for approximately 45 minutes. These thermal images show warm and cool regions of the head and hands in warm and cold room environments. A cold room environment corresponds with the environment of some operating rooms, whereas a warm room corresponds to other locations. FIG. 3A shows a thermal image of a person's head and hands when the person is located in a room maintained at approximately 72° F. (22° C.) (warm room). As can be seen from this figure, regions **302**, which include the head, the fingers and the ears are warm skin regions, indicating regions where there is adequate blood perfusion and hence regions where good oximetry readings can be obtained. In contrast, FIGS. 3B-C show thermal images of the same person as in FIG. 3A, after she has been exposed to a cold room maintained at approximately 58° F. (14.4° C.) for approximately 45 minutes. These figures (FIGS. 3B-C) show that after the exposure to the cold room, region **304**, (the head) is the only warm region, whereas the fingers **306**, the nose **308** and the ears **310** are cold, indicating regions where there is inadequate blood perfusion and hence regions where poor pulse reading are expected to occur.

FIG. 4 is a graph showing pulse amplitude signal variations due to a change in the environment's temperature obtained from various sensors located at various locations on a patient's body. This figure shows pulse amplitudes (e.g., % IR [infrared] modulations) obtained using finger, ear, and forehead sensors for humans in a warm room and a cold room. Shown in this figure are the changes in pulse amplitude caused by cold-induced vasoconstriction. As can be seen, the forehead is not significantly affected, while ear and fingers show a strong vasoconstrictive response, because the pulse amplitude obtained by the forehead sensor shows no significant change as the patient is moved from a warm to a cold room. The results of this graph indicate that the lower-forehead region where the forehead sensors were applied provides the most stable pulsatile signal strength of the three sites during vasoconstriction. Other results indicate that the head provides an earlier indication of changes in SaO₂ than other sites due to a phenomenon known as circulation delay. This phenomenon provides that hands or fingers, especially in a cold room (e.g., operating room in a surgical unit) see changes in core arterial oxygen saturation events up to a minute later than when it occurs. Clearly such delays can adversely impact a patient's condition.

A reason for this vasoconstrictive effect is understood by examining the arteries of the head region, as shown in FIG. 5. This figure shows that the external carotid artery feeds most of the head skin including the ears. The lower-forehead skin is fed by the supraorbital artery, which arises from the internal carotid artery. The external carotid artery does not supply the brain, and the circulation it supports shows more vasoactivity and vasoconstrictor reflexes that the circulation of the lower-forehead region. Referring to FIG. 6, it is shown that the same internal carotid artery source that supplies blood to the eyes and brain supplies the skin directly above the eyebrows. The external carotid artery supplies other facial tissues. Vasoconstrictive response affects the internal branch of the carotid artery less than the external branch of the carotid artery. Therefore, since the lower-forehead blood flow stems from the same circulation that feeds the brain, it is less affected by vasoconstriction, and hence is a more stable and predictable location for oximetry sensor placement.

Having identified and understood why that the lower forehead region is a preferred location for placing an oximeter sensor, a preferred location on the lower forehead is next described. A preferred sensor placement enables a sensor to optically probe arterial circulation that is fed by the internal carotid artery. In addition, such a preferably-placed sensor probes richly perfused regions of the microvasculature, with little interference from larger blood vessels; and also probes cardiac-induced pulsating arterial blood, with little interference from venous pulsations. FIG. 7 shows such a sensor location to be the lower forehead region 702, immediately above the eyebrow 704, with both the sensor optics (i.e., emitter and detector) located lateral of the iris 706 and proximal the temple. Alternately, the preferred sensor placement is one where the sensor's emitter and the detector are directly above the eyebrow, such that the emitter and detector are both located lateral of the supratrochlear and supraorbital arteries and medial the superficial temporal artery, or in other words, placing the emitter or detector directly above the center of the eye close to the eyebrow, and the other (detector or emitter) approximately horizontally located towards the sides of the head, a few millimeters away (e.g., 2-3 mm to 15 mm). Preferably, the sensor emitter or detector is placed within ± 5 mm of the vertical line passing through the location of the iris, more preferably 0 mm-3 mm lateral the iris, and the other of the emitter and detector is placed horizontally lateral this location. Preferably also, the axis connecting the sensor optics is placed within 10 mm of the top of the eyebrow, and more preferably within 5 mm. This placement site is preferred because it experiences little vasoconstriction since the circulation in this region is fed by the internal carotid artery. In addition, this region is preferred because it experiences strong pulsatile signals, with little interference from large blood vessels.

A review of FIG. 7 also shows locations that are less preferred locations for the placement of a forehead sensor. For example, the region of the upper or center of forehead, scalp and facial regions are less preferred region for sensor placement, because this region has superficial vasoactive vessels perfused with blood from external carotid circulation. In addition, sites over large blood vessels, such as the temporal artery are also a lesser-preferred location for sensor placement. For sites over the large blood vessels, the SpO₂ readings become unreliable when the sensor light probes large light-absorbing objects that move or change diameter with the heartbeat, where both red and infrared light signals become similarly modulated by the highly opaque vessels, unrelated to the oxygen saturation of arterial blood. Regions over large pulsing blood vessels, such as the temporal and proximal

regions of the supraorbital arteries themselves, should preferably not be used as sensor placement sites.

FIG. 8 shows an infrared thermal image of a human head illustrating a proper sensor placement. This figure shows the cooler region 802 in and around the nose to be a less preferred location for sensor placement, because the tissue in this region has smaller pulses, and because the region is subject to vasoconstriction. This figure also shows that region 804 being the warmest region is also a lesser preferred region for sensor placement, because the regions directly above larger vessels (hence warmer) are subject to cardio-synchronous vessel movement. In region 804, while the pulsatile signal strength may seem desirable, SpO₂ readings could be unreliable. In contrast, region 806, which is above and lateral the center of either eyebrow, is a preferred sensor placement location. As is shown in the figure, a preferred placement for a forehead sensor, such the sensor described in co-pending U.S. patent application Ser. No. 10/256,245, entitled: "Stacked Adhesive Optical Sensor," is to place the emitter above and slightly lateral the iris, with the sensor cable routed back towards the ear. Accordingly, a method for determining a location for the placement of an oximetry sensor, includes: measuring the temperature of a plurality of locations on an area of the body of a patient; dividing the temperature measurements into three categories, namely cold, warm and hot regions; rejecting the hot areas corresponding to areas over large movable blood vessels as a location for the placement of the sensor; rejecting the cold areas corresponding to areas susceptible to vasoconstriction as a location for the placement of the sensor; and selecting the area that is not hot and not cold as a location for the placement of the sensor. The temperature measurement apparatus can be a thermal strip that is made part of the sensor. Alternately, the temperature measurement apparatus may be a part of a sensor attachment device, such as a headband or a hat. Yet alternately, the temperature measurement apparatus may be a separate temperature measurement device packaged with the sensor or the attachment device. Another method for identifying regions over larger cardio-synchronously moving vessels is to palpate the skin; regions in which pulses can be felt to the touch should be avoided, while regions with no or minimal pulsations present represent preferred locations for sensor placement.

In light of the disclosures directed to determining a proper sensor placement location, the sensor's mechanical design itself can be configured for efficient locating on the forehead and above the eye. Such a design has a sensor height (or width) that is smaller than its length. For example, a sensor with a height (or width) smaller than 5 millimeters and length between 6-15 mm satisfies such a configuration. The remaining details of such a sensor are disclosed in the above-referenced and co-pending U.S. patent application Ser. No. 10/256,245, entitled: "Stacked Adhesive Optical Sensor."

As set forth above, an attachment device is described in a co-pending U.S. patent application Ser. No. 11/495,195, entitled: "FOREHEAD SENSOR PLACEMENT." So, in addition to above disclosures directed to the placements of an oximetry sensor, such placements may include the positioning of a headband device over the sensor to hold the sensor in place on the patient's forehead and also to provide a gentle pressure to the forehead sensor.

Alternately, the forehead sensor can be integrated with a sensor attachment device, such as a headband. FIG. 9 is an assembly drawing of an embodiment of a headband-integrated sensor. A headband-integrated sensor provides for a more secure and stable placement of a sensor on a patient's forehead than that of two-piece device having a separate sensor and a headband, especially for patient's who move

excessively, such as neonate patients. For such patients it is much easier to apply one integrated sensor, as opposed to applying a sensor and then a separate headband over the sensor. FIG. 9 shows an oximeter sensor placed on a substrate 902 that can be placed, adhered, or integrated into a headband 904. In the headband-integrated embodiment, the sensor uses an emitter 906 containing two discrete wavelengths and a detector 908 placed more than 2 mm away, and ideally 10 mm-15 mm from the emitter. The surface 902 can be black in order to minimize any shunting of light between sensor and patient skin. The sensor in a headband could be used in conjunction with a small, portable oximeter to allow mobility of the user during activities. Also shown in FIG. 9 is a cable 910 for providing drive current to the LED and for providing the detector signal to the oximeter. The cable provides the electrical connection to the monitor; it also provides power for the emitter, signal carrying conductors from the detector, and shielding to protect the small signals from the detector against external electrical interference.

The sensor is shown in a multi-layer structure having a face portion 912. The face 912 is the surface that is placed against the patient's skin. The face material may have an adhesive layer such as an acrylic or synthetic rubber adhesive, or it may be without adhesive, and typically made from a foam PVC or foam polyurethane material. The face 912 component is preferably black so as to minimize the incidence of reflected light that does not go through the tissue. Below the face layer 912 are two windows 914. The windows 914 are generally a clear component, such as for example, a thin film or a clear molded plastic component that makes contact with the skin. The thin film window may be a polyurethane or an acrylic adhesive on a polyester film. The intent of the window 914 is to provide an efficient optical coupling mechanism between the optical components (emitter and detector) and the skin. Located above the face 914, is a Faraday shield 916. The Faraday shield 916 is a conductive material, for example, a copper film or copper mesh, that is electrically connected to the monitor ground to help shield the detector from extraneous electrical interference while passing light to the detector. Next located are the LED 906 and the detector 908. Above the LED and the detector is a mask layer, which may include more than one mask layer. The mask layer 918 is generally a thin film that is intended to block light from entering the back side of the sensor, or from traveling directly from emitter to detector (shunt light). The purpose of the mask 918 is to ensure that all of the light reaching the detector is light from the emitter that has traveled through the capillary bed. Above the mask layer 918 is the back layer 920. The back or the top layer is the non-tissue contacting surface of the sensor. This layer may include a cosmetic finish for the sensor, which can be white with some printed artwork identifying the sensor. Typical materials may be Velcro loop, or soft PVC foam.

FIG. 10 is a graph of the relationship between Lag Time in detecting a change in oxygenation status of a patient and Pulse Amplitude. FIG. 10 shows the head to finger time delay in seconds vs. pulse amplitude in % infrared (IR) modulation for values taken in a warm room as well as those taken in a cold room as observed in healthy volunteers. This figure shows a clear clustering of the data points, where the data points taken in a cold room and hence indicative of vasoconstriction all show small pulse amplitude values (e.g., less than 1.5%) and longer head to finger lag times. On the other hand, the data points corresponding to values not impacted by vasoconstriction (warm room data) show a small time lag and larger pulses. Accordingly, a method for determining a location for the placement of an oximetry sensor includes: measuring pulse modulation value, comparing the modulation

value to a threshold, and recommending a new sensor location to be chosen by the caregiver. This recommendation has particular value when the initial sensor placement is peripherally located, such as on a finger. The recommendation may be made by the monitor coupled with the sensor using an algorithm being executed by the monitor and communicated to a caregiver using the monitor's audible or visual indicators.

As will be understood by those skilled in the art, the present invention may be embodied in other specific forms without departing from the essential characteristics thereof. These other embodiments are intended to be included within the scope of the present invention, which is set forth in the following claims.

What is claimed is:

1. A method of determining a physiological parameter using a pulse oximeter, comprising:

placing an oximetry sensor comprising an arcuate substrate having an emitter and a detector on a lower forehead region of a patient, such that the emitter and the detector are placed about a line centered over the iris such that the emitter or the detector is on one side of the iris and that the other of the emitter or the detector is on the other side of the iris; and

operating the pulse oximeter to obtain the physiological parameter.

2. The method of claim 1, wherein the placing comprises placing the sensor such that an axis connecting the emitter and the detector lies within 8 mm of the top of the patient's eyebrow.

3. The method of claim 1, wherein the placing comprises placing the sensor such that an axis connecting the emitter and the detector lies within 5 mm of the top of the patient's eyebrow.

4. The method of claim 1, wherein the substrate is resilient and has a shape conformable to the lower forehead of the patient.

5. The method of claim 1, wherein the emitter and detector are disposed on the substrate such that an axis connecting the emitter and the detector does not bisect the substrate.

6. The method of claim 1, comprising providing a headband comprising an elastic segment sized to fit around the patient's head and a non-elastic segment being smaller than and attached with the elastic segment, the non-elastic segment sized to span a portion of the elastic segment when the elastic segment is stretched, the non-elastic segment being larger than the portion of the elastic segment it spans when the elastic segment is not stretched; and

placing the headband over the oximetry sensor.

7. The method of claim 6, wherein the non-elastic segment is attached with the elastic segment in such a manner that the non-elastic segment projects out from the surface of the elastic portion when the headband is not sufficiently tight, thus creating a loop which provides a visual indication that the headband needs re-tightening.

8. The method of claim 1, wherein the physiological parameter is an oxygen saturation value.

9. The method of claim 1, wherein the physiological parameter is a pulse rate.

10. A system comprising:

a monitor configured to determine a physiological parameter based at least in part upon a signal related to the physiological parameter; and

a sensor coupled to the monitor and capable of generating the signal related to the physiological parameter, the sensor comprising:

a substrate being adapted to directly contact a portion of a forehead of a patient, wherein the substrate is arcu-

9

ate when placed flat upon a planar surface in the absence of any restraining force;
 an emitter and a detector disposed on the substrate; and
 a headband configured to hold the substrate against the patient's forehead, the headband sized to fit around the patient's head, wherein the headband comprises:
 an elastic segment sized to fit around a patient's head; and
 a non-elastic segment being smaller than and attached with the elastic segment, wherein the exterior side of the elastic segment generally faces away from the wearer when the headband is applied to the wearer's head, and the non-elastic segment sized to span a portion of the elastic segment when the elastic segment is stretched, the non-elastic segment being larger than the portion of the elastic segment it spans when the elastic segment is not stretched, wherein the non-elastic segment is sized to not project out from the surface of the elastic portion when the headband is sufficiently tight thus indicating an adequate level of tension corresponding with delivering a pressure in the range higher than the venous pressure and lower than the capillary pressure to the forehead of the patient.

10

11. The system of claim 10, wherein the substrate is resilient and has a shape conformable to the forehead of a patient.

12. The system of claim 10, wherein the substrate is adhered to the inside of the headband.

13. The system of claim 10, wherein the physiological parameter is an oxygen saturation value.

14. The system of claim 10, wherein the physiological parameter is a pulse rate.

15. The system of claim 10, wherein the headband comprises a closure mechanism coupled with the elastic portion.

16. The system of claim 15, wherein the closure mechanism is a hook and loop closure, a snap, a button, an adhesive, a pin, or any combination thereof.

17. The system of claim 10, wherein the elastic segment is rectangular shaped having a long and a short dimension, and the non-elastic segment is attached along a set of its edges with the elastic segment, wherein the set of edges are generally parallel to the short dimension.

18. The system of claim 10, wherein the non-elastic segment is attached with the elastic segment in such a manner that the non-elastic segment projects out from

the surface of the elastic portion when the headband is not sufficiently tight, thus creating a loop which provides a visual indication that the headband needs re-tightening.

* * * * *

专利名称(译)	前额传感器放置		
公开(公告)号	US8452367	公开(公告)日	2013-05-28
申请号	US12/843651	申请日	2010-07-26
[标]申请(专利权)人(译)	内尔科尔普里坦贝内特公司		
申请(专利权)人(译)	NELLCOR PURITAN BENNETT LLC		
当前申请(专利权)人(译)	COVIDIEN LP		
[标]发明人	MANNHEIMER PAUL D HANNULA DON L BEBOUT DONALD E ONEIL MICHAEL PATRICK		
发明人	MANNHEIMER, PAUL D. HANNULA, DON L. BEBOUT, DONALD E. O'NEIL, MICHAEL PATRICK		
IPC分类号	A61B5/1455 A41D20/00 A61B5/00		
CPC分类号	A41D20/00 A61B5/14552 A61B5/6814 A61B5/01		
优先权	60/415468 2002-10-01 US		
其他公开文献	US20110009723A1		
外部链接	Espacenet USPTO		

摘要(译)

前额血氧测定传感器装置和使用前额血氧测定传感器确定生理参数的方法。一种方法包括将血氧测量传感器放置在患者的前额上，使得传感器放置在眉毛上方的下前额区域上，传感器光学器件放置在虹膜的侧面并靠近镜腿；并操作脉搏血氧仪以获得生理参数。在一个方面，该方法还包括在血氧测定传感器上提供和放置头带，或者，传感器是头带集成传感器。头带具有弹性段，其尺寸适合于围绕患者头部。头带还包括非弹性段，该非弹性段小于弹性段并与弹性段连接。当弹性段被拉伸时，非弹性段的尺寸设计成跨越弹性段的一部分。另外，当弹性段未被拉伸时，非弹性段大于其跨越的弹性段的部分。当头带或头带集成传感器足够紧密时，它提供的压力范围高于静脉压并且低于患者前额的毛细血管压力。

