



US007255672B2

(12) **United States Patent**  
**Elliott**

(10) **Patent No.:** **US 7,255,672 B2**  
(45) **Date of Patent:** **Aug. 14, 2007**

(54) **METHOD OF PRESENTING AUDIBLE AND VISUAL CUES FOR SYNCHRONIZING THE BREATHING CYCLE WITH AN EXTERNAL TIMING REFERENCE FOR PURPOSES OF SYNCHRONIZING THE HEART RATE VARIABILITY CYCLE WITH THE BREATHING CYCLE**

2002/0051958 A1\* 5/2002 Khalsa ..... 434/238  
2005/0149144 A1\* 7/2005 Siever ..... 607/45

**FOREIGN PATENT DOCUMENTS**

GB 2344288 A \* 6/2000  
GB 2381642 A \* 5/2003

**OTHER PUBLICATIONS**

Bernardi et al., "Effect of rosary prayer and yoga mantras on autonomic cardiovascular rhythms: comparative study", Dec. 22-29, 2001, BMJ, 323, 1446-1449.\*  
Bernardi et al., Effect of rosary prayer and yoga mantras on autonomic cardiovascular rhythms: comparative study, Dec. 2001, BMJ, vol. 323, pp. 1446-1449.\*  
Gardner-Gordon, The Healing Voice: Traditional and Contemporary Toning, Chanting and Singing, 1993, The Crossing Press, pp. 57-58, 63, 70, 121-126.\*

\* cited by examiner

*Primary Examiner*—Charles A. Marmor, II  
*Assistant Examiner*—Sara Lustusky  
(74) *Attorney, Agent, or Firm*—Withrow & Terranova, PLLC

(75) Inventor: **Stephen Bennett Elliott**, Allen, TX (US)  
(73) Assignee: **Coherence LLC**, Allen, TX (US)  
(\* ) Notice: Subject to any disclaimer, the term of this patent is extended or adjusted under 35 U.S.C. 154(b) by 461 days.

(21) Appl. No.: **10/802,456**

(22) Filed: **Mar. 18, 2004**

(65) **Prior Publication Data**  
US 2005/0209503 A1 Sep. 22, 2005

(51) **Int. Cl.**  
*A61M 21/00* (2006.01)  
(52) **U.S. Cl.** ..... **600/27; 600/26; 600/28**  
(58) **Field of Classification Search** ..... **600/26-28; 368/10, 107-113; 434/238; 607/88; 424/238**  
See application file for complete search history.

(57) **ABSTRACT**

The invention consists of a broad method of presenting audible and visual cues for synchronizing the breathing cycle with an external timing reference for purposes of synchronizing the heart rate variability cycle with the breathing cycle, thereby achieving coherence of the heart rate variability cycle. A family of audible and visual indicators is specified for purposes of communicating breathing phase, change of breathing phase, progression of time within a phase, and progression of the phase relative to the internal perception of the practitioner.

(56) **References Cited**  
**U.S. PATENT DOCUMENTS**  
1,953,954 A \* 4/1934 Constable ..... 434/30  
4,711,585 A \* 12/1987 Fresquez et al. .... 368/109  
6,212,135 B1 \* 4/2001 Schreiber ..... 368/107  
6,397,106 B1 \* 5/2002 DeBrouse ..... 607/69

**9 Claims, 8 Drawing Sheets**

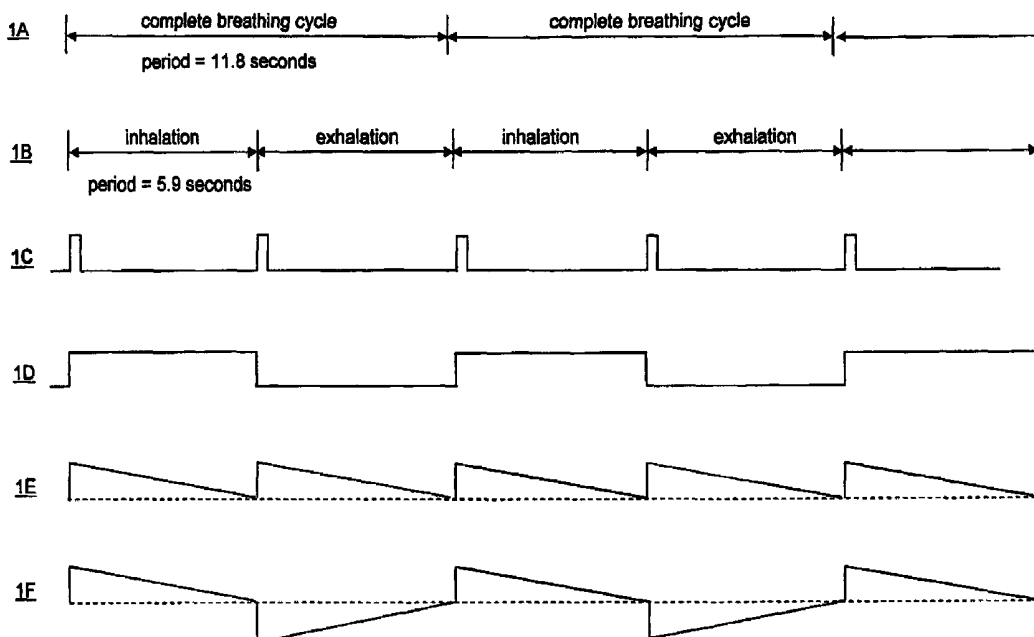

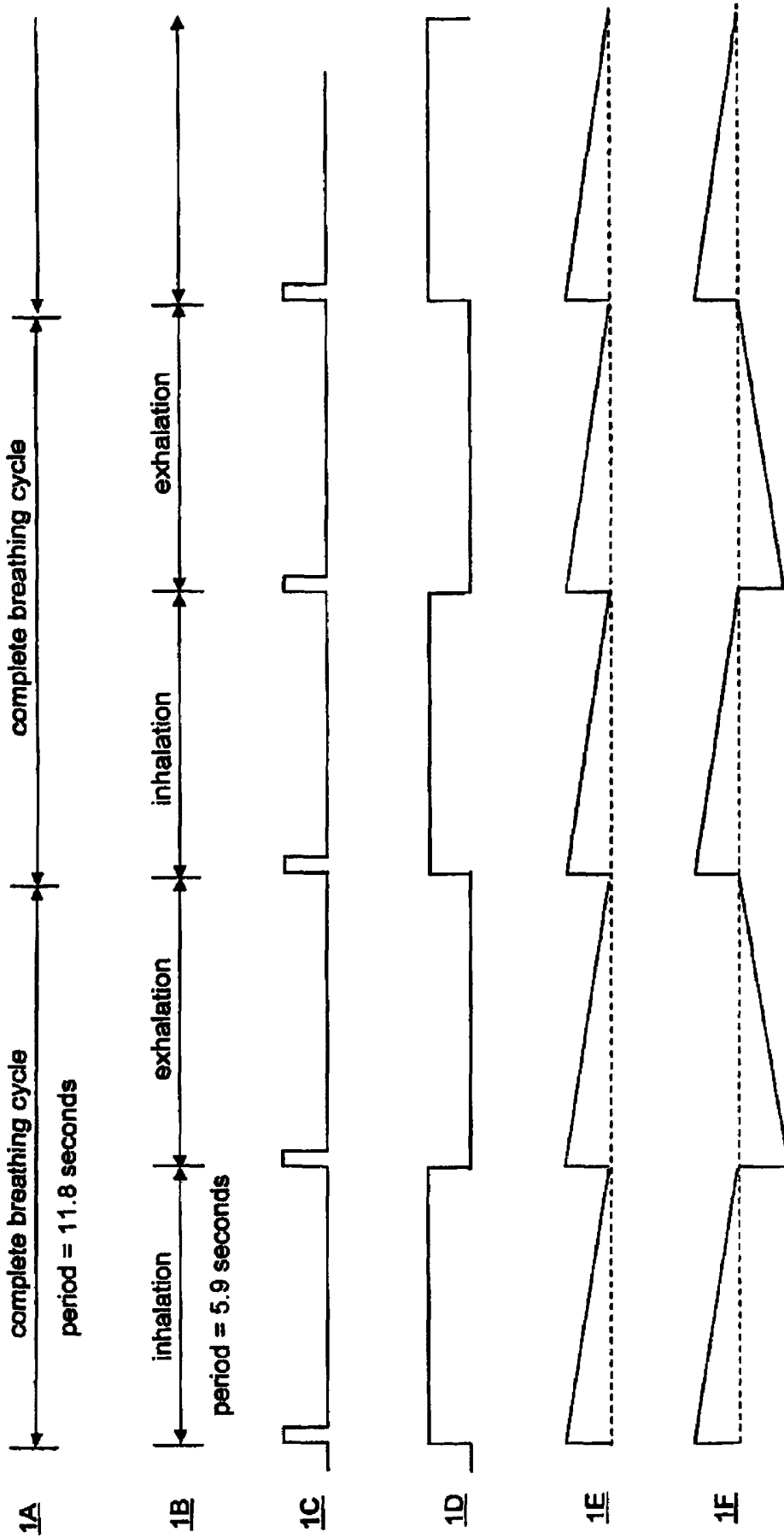

**FIGURE 1**

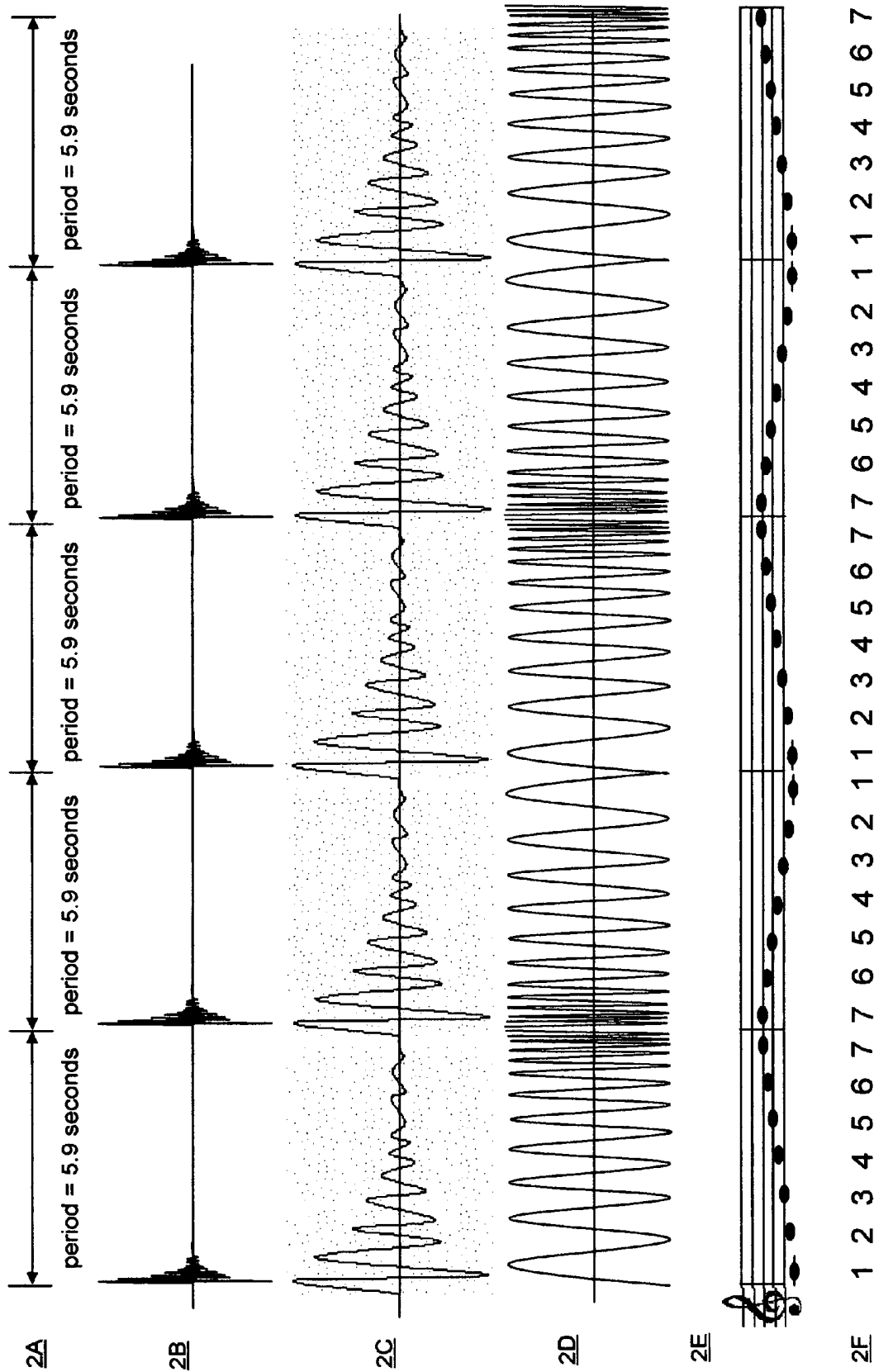

FIGURE 2

**Silent Night**  
F. Gruber (19th c.)

32 *Andante* Eb

31 Si - lent night, ho - ly night! All is

33 chime

34 chime F7

35 chime Bb calm, all is bright

36 chime Eb 'Round you Vir - gin

37 chime

38 interval = 5.9 seconds

interval = 5.9 seconds

The image shows a musical score for the song 'Silent Night' by Franz Gruber. The score is written in 4/4 time with a key signature of one flat (Bb). It features a piano accompaniment and a vocal line. The piano part includes a circled tempo marking 'Andante' and a key signature change to Eb. The vocal line includes lyrics: 'Si - lent night, ho - ly night! All is calm, all is bright 'Round you Vir - gin'. Annotations include 'chime' labels with arrows pointing to specific notes in the piano part at measures 33, 34, 35, 36, and 37. A bracket labeled '38' spans two intervals between these chime notes, with arrows indicating that each interval is 5.9 seconds. The score is numbered 31 through 37.

**FIGURE 3**

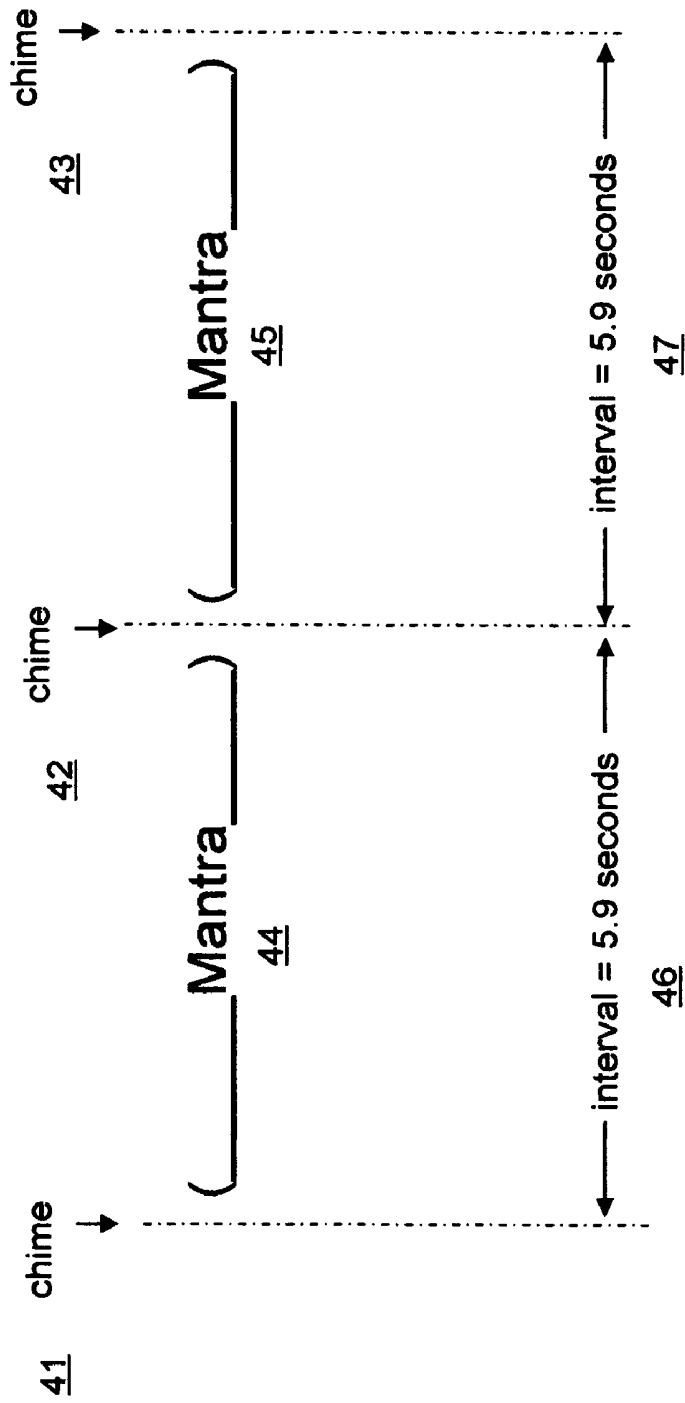

FIGURE 4

51

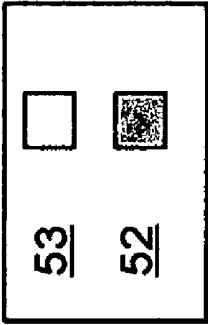
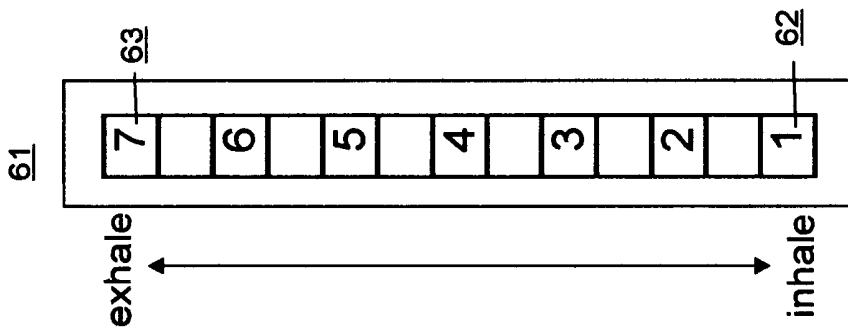

FIGURE 5



64

7	purple
6	indigo
5	cyan
4	green
3	yellow
2	orange
1	red

FIGURE 6

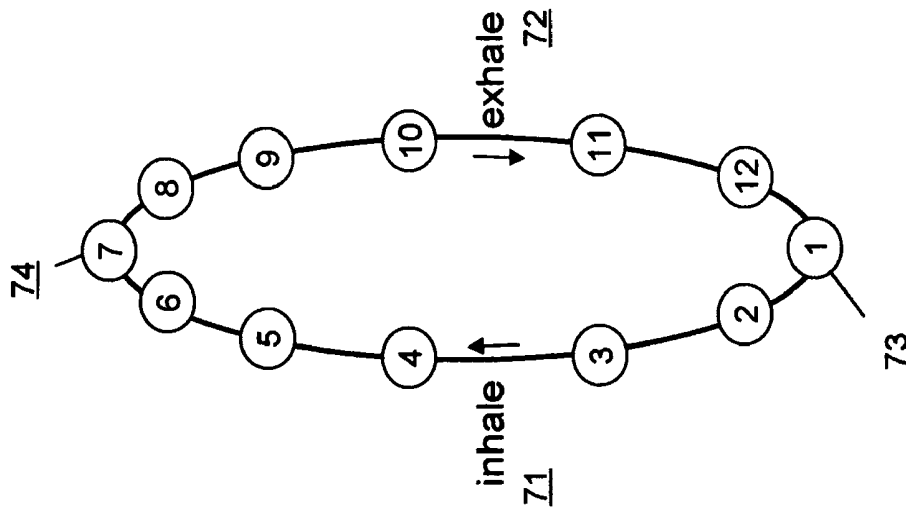

75

Inhale	Color	Exhale
7	purple	7
6	indigo	8
5	cyan	9
4	green	10
3	yellow	11
2	orange	12
1	red	1

FIGURE 7

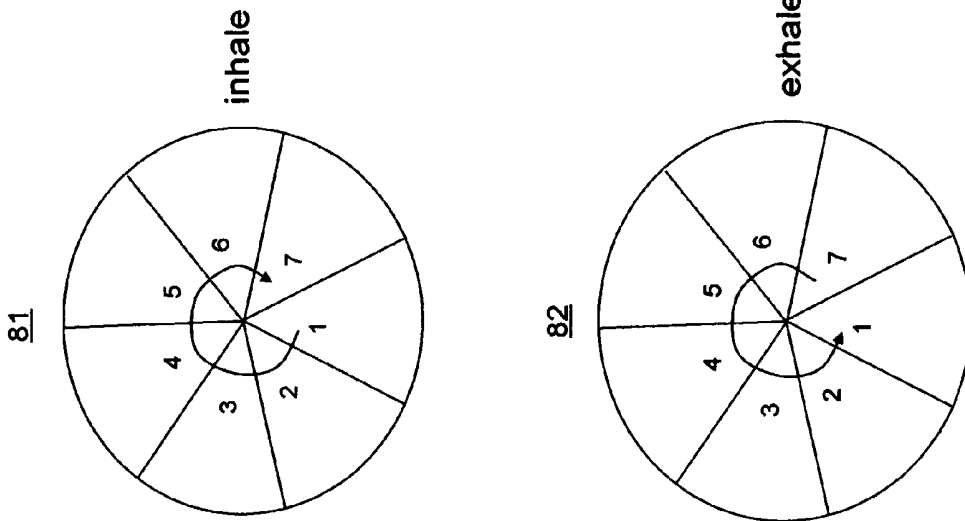

83

7	purple
6	indigo
5	cyan
4	green
3	yellow
2	orange
1	red

FIGURE 8

1

**METHOD OF PRESENTING AUDIBLE AND VISUAL CUES FOR SYNCHRONIZING THE BREATHING CYCLE WITH AN EXTERNAL TIMING REFERENCE FOR PURPOSES OF SYNCHRONIZING THE HEART RATE VARIABILITY CYCLE WITH THE BREATHING CYCLE**

RELATED PATENT FILINGS

Method and System for Consciously Synchronizing the Breathing Cycle with the Natural Heart Rate Cycle (Ser. No. 10/699,025), Method and System for Synchronizing the Heart Rate Variability Cycle With The Breathing Cycle (Feb. 19, 2004).

FIELD OF THE INVENTION

The present invention relates to human physiology, and in particular to a method and system for allowing a human subject to consciously control physiological processes, more particularly, it allows a human subject to achieve synchronization of the natural cycle of heart rate with the breathing cycle.

BACKGROUND OF THE INVENTION

The human heart is known to have its own nervous system and its own natural tendency toward rhythm. For purposes of this invention, there are two primary aspects to this rhythm, the heartbeat rate, and the rate at which the heartbeat rate changes otherwise known as heart rate variability. Heartbeat rate is usually specified in absolute number of heartbeats occurring during a specified period. Heartbeat rate variability, otherwise known as heart rate variability is the change in heartbeat rate as occurs during a specified period. Henceforth, heartbeat rate variability will be referred to as heart rate variability.

While the heart has its own tendency toward rhythm, it is closely coupled to breathing. The relationship is such that as inhalation occurs, the heartbeat rate tends to increase and as exhalation occurs, the heartbeat rate tends to decrease. It is important to note that while the heartbeat rate and breathing rate influence each other, the relationship is a plesiochronous one, that is, they are independent rhythms that strongly influence but do not directly control each other.

It is generally recognized that heart rate variability is an indicator of physiological and emotional state, that is, irregular incoherent heart rate variability indicates a condition of physiological/psychological stress. Alternatively, a highly regular coherent heart rate variability is indicative of a condition of physiological/psychological harmony.

Accordingly, it is highly desirable to achieve and maintain a highly coherent heart rate variability as life circumstances permit. This having been said, with proper training and the application of the present invention, it is possible for a human subject to rapidly achieve the desired state of high coherence of heart rate variability and to reinforce that coherence on an ongoing basis.

The present invention takes advantage of the relationship between the breathing cycle and the natural heart rate variability cycle to bring heart rate variability to the desired state of coherence and the human subject to the resultant state of physiological and emotional harmony. It accomplishes this via synchronization of the heart rate variability cycle with the breathing cycle. More specifically, it accomplishes this by providing audible and visual cues of varying

2

formats which provide the practitioner with an accurate representation of a timing reference signal to which the breathing cycle is consciously synchronized.

SUMMARY OF THE INVENTION

As previously described, a relationship exists between the heartbeat rate specified in terms of heart rate variability, and the breathing cycle. While the heart has its own tendency toward a natural variable rhythm, there is a strong correlation with breathing according to this specific relationship: as inhalation occurs, there is a tendency for the heartbeat rate to increase, as exhalation occurs, there is a tendency for the heartbeat rate to decrease. In a relaxed or semi-active human subject, the effect of the breathing cycle on the heart rate variability cycle is extremely strong. In fact, the heart rate variability cycle will synchronize with the breathing cycle if the breathing cycle is highly attuned to the periodicity of the natural heart rate variability cycle. The nominal period of the typical human heart rate variability cycle is 11.76 seconds. Therefore, if the period of the breathing cycle is timed to 11.76 seconds, the heart rate variability cycle will synchronize with it, bringing the natural heart rate variability cycle into phase synchrony with the breathing cycle and thereby bringing the subject's heart rate variability cycle into the desired state of coherence.

The present invention accomplishes this by presenting the human subject with various forms of audible and visual cues individually or in combination to which the breathing cycle is consciously synchronized. These audible and visual cues are synchronous signals with a nominal periodicity of 11.76 seconds divided by 2, or 5.88 seconds, representing the 50% of the typical 11.76 second heart rate variability cycle and corresponding to 50% of the breathing cycle of like period, that is, the period of inhalation or exhalation. When the breathing is consciously synchronized to this external timing reference signal, the heart rate variability cycle will synchronize with it and remain synchronized as long as the breathing cycle remains aligned with the tuned external reference. In this way, the human subject can remain in the desired state of coherence of heart rate variability for extended periods of time. Ultimately, this builds familiarity with the desired psycho-physiological condition such that synchronization with the external reference occurs subliminally and with continued practice, the state can be realized at will with or without the external timing reference signal.

For purposes of the present invention, we can consider the cycles of heart rate variability, the periodicity of increasing and decreasing of heartbeat rate, and the breathing cycle, the periodicity of inhalation and exhalation, to be two independent cycles. The relative synchronization of these cycles can vary between 0 and 180 degrees. When these cycles are completely out of phase, heart rate variability is maximally incoherent, when these cycles are completely in phase heart rate variability is maximally coherent.

BRIEF DESCRIPTION OF THE DRAWING FIGURES

The accompanying drawing figures incorporated in and forming a part of this specification illustrate several aspects of the invention, and together with the description serve to explain the principles of the invention.

FIG. 1 depicts the fundamental periodicity and logical representations of audible and visual indicators of varying utility;

FIG. 2 depicts various methods of presenting audible information representing the synchronized breathing cycle;

FIG. 3 presents an example of music with a tempo and audible cues specifically designed to align the breathing with a period of 5.9 seconds;

FIG. 4 presents an example of "mantra," a word or phrase that is repeated over and over, again designed to align the breathing with a period of 5.9 seconds;

FIG. 5 presents various methods for presenting visual information representing the objective breathing cycle;

FIG. 6 presents a vertically-oriented thirteen (13) segment visual display;

FIG. 7 presents a vertically-oriented oval visual display with 12 segments; and

FIG. 8 presents a seven (7) sector circular visual display.

#### DETAILED DESCRIPTION OF THE PREFERRED EMBODIMENTS

The present invention describes a series of related audible and visual methods by which information relating to the periodicity of an external timing reference is conveyed to a human practitioner for purposes of synchronizing their breathing cycle with the external reference signal for purposes of synchronizing their heart rate variability cycle with their breathing cycle. It is understood that these methods may ultimately be instantiated in any number of devices employing numerous forms of media including audio tape, compact disk, digital video disk, computers, hardware or software synthesizers, telephones, cellular telephones, televisions or radio broadcast, clocks, watches, and purpose built specialty devices. Secondly, audible forms of the invention may be instantiated in any or all forms of audible media including but not limited to music, background ambience generators, clocks of varying variety such as grandfather clocks, alarm clocks, telephones, and audible network based services such as radio stations, internet based services, and purpose built specialty devices. Thirdly, it is understood that there are an infinite number of variations possible relative to how an external timing reference may be communicated to a human participant or participants for the purpose of consciously synchronizing the participant's breathing with the external timing reference. The embodiments set forth below represent the necessary information to enable those skilled in the art to practice the invention and illustrate the best mode of practicing the invention. Upon reading the following description in light of the accompanying drawing figures, those skilled in the art will understand the concepts of the invention and will recognize applications of these concepts not particularly addressed herein. It should be understood that these concepts and applications fall within the scope of the disclosure and the accompanying claims.

The present invention allows a human subject to achieve coherence of heart rate variability by synchronizing the heart rate variability cycle with the breathing cycle. This is accomplished by providing an external timing reference in the form of an audible or visual signal, indicating when the subject should begin inhalation and when the subject should begin exhalation. In some cases, more complete information is provided indicating when the subject should begin inhalation, when the subject should end inhalation, when the subject should begin exhalation, and when the subject should end exhalation. This is repeated in a cyclic fashion, inhalation leading to exhalation, exhalation leading to inhalation, and so forth. The audible or visual reference signal is centered around the nominal frequency of 0.085 Hertz for a

period of approximately 11.8 seconds, the center heart rate variability period of the typical human in a resting or semi-active state. When the typical human subject breathes at this rate, the heart rate variability cycle will synchronize with the breathing cycle, thereby maximizing the coherence of the heart rate variability cycle.

FIG. 1 presents basic timing and audible and visual functions in a logical format. The most basic information that must be conveyed to a subject or subjects practicing the method is the basic periodicity of the nominal 11.8 second breathing cycle 1A, divided by 2, yielding a 5.9 second period of inhalation and a 5.9 second period of exhalation 1B. This most basic indication is conveyed in the form of an audible or visual indicator of short duration 1C indicating when to change from inhalation to exhalation or when to change from exhalation to inhalation. 1D conveys this information as a change of phase, that is, a change from inhalation to exhalation or the reverse. Because very exacting coordination of the breath is required, a higher order signal indicating the moment of change as well as the progression of time is desirable 1E. Yet a further improvement that conveys change, progression, and distinguishes between inhalation and exhalation phases of activity is depicted by 1F.

To maximize heart rate variability coherence, it is extremely important that the timing of transitions from inhalation to exhalation and exhalation to inhalation be very exact. For this reason, it is highly desirable to provide the practitioner with audible or visual information such that they can understand breathing progression within a cycle, that is, within the 5.9 second period. By providing information relating to both progression and changes, the practitioner is much more able to align their breathing cycle with the external reference signal in an exacting fashion.

With reference to FIG. 2, six basic methods for communicating audible information are exemplified. Each method will now be explained. 2A depicts the basic 5.9 second period to which the breath is aligned. 2B is the most basic case representing a tone, chime, or tick conveying information pertaining to the change of the breathing cycle, that is, with each tone, chime, or tick, the breathing cycle changes from inhalation to exhalation or from exhalation to inhalation.

2C depicts the case where information pertaining to both change and progression is provided. This case might be typified by plucking the string of a stringed instrument such as a guitar wherein there is a rapid attack followed by a gradual decay, the rapid attack representing the moment of change of the breathing cycle and the gradual decay representing the progression of the 5.9 second interval. In this exemplary embodiment, the rapid attack occurs every 5.9 seconds. The decay occurs across the 5.9 second interval such that the audio amplitude becomes zero just prior to the next attack, indicating to the practitioner that a change in breathing cycle is imminent.

2D employs frequency modulation as the basis of indicating changes and progression. In this case, an audible tone is varied in frequency, the highest and lowest frequencies indicating the moment of the change in the breathing cycle from inhalation to exhalation or from exhalation to inhalation, respectively. This method has the advantage of facilitating inhalation with increasing frequency and exhalation with decreasing frequency, a convention that is useful both for audible-only cuing and for combined audible and visual cuing as will be explained later.

2E employs a similar method to that of 2D but using discrete musical notes as opposed as a continuously variable

tone. In this example, changes in breathing cycle occur in between the two highest and two lowest notes. In this example, 7 notes are employed to represent the 5.9 second period. It should be noted that 7 notes represents a preferred embodiment of the present invention and that the application of any number of notes within a 5.9 second period provided for purposes of synchronizing breathing either consciously or subconsciously is intended within the scope of this disclosure. 2E provides the same advantage offered by 2D, that being the facilitation of inhalation with increasing frequency and exhalation with decreasing frequency. The seven successive notes C, D, E, F, G, A, and B occurring during the 5.9 second period is intentional, the number 7 being used consistently between both audible and visual presentations. Each note is sustained for a period of approximately 0.84 seconds.

FIG. 2F employs the simple method of counting, that is, the recitation of numbers 1 through 7 and 7 through 1. In this example, as in 205, changes in breathing cycle occur in the between the two highest numbers and two lowest numbers. Again this case offers the advantage of facilitating inhalation with increasing number and exhalation with decreasing number.

Referring now to FIG. 3, an essential embodiment of the present invention involves the adjustment of musical tempo and integration of audible cues into musical scores for the purpose of identifying the beginning and end of the 5.9 second interval such that both singers and or listeners are able to employ the music for purposes of synchronizing their breathing to the audible cues and thereby achieving coherence of their respective heart rate variability cycles. The score of Silent Night 31 is used for this example. In this case, the tempo 32 is adjusted to allow markers to be inserted at 5.9 second intervals while in keeping with the basic tempo of the musical piece. In this example, chime 33, 34, 35, 36, 37 is inserted every 5.9 seconds 38. The chime or equivalent musical cue can be integrated into the music at the time the music is being played or can be mixed in post recording. Of course, the degree to which the marker integrates pleasantly with the score has to do with the tempo of the music and the degree to which it conforms with the 5.9 second interval.

FIG. 4 depicts the application of the 5.9 second breathing interval to the repetition of "mantra", mantra 44, 45 typically being a short verse or phrase of spiritual significance that is repeated over and over again. In this example, the 5.9 second interval 46, 47, is delineated by a chime 41, 42, 43 that occurs at the beginning of each 5.9 second interval. The mantra itself may fill this 5.9 second interval as well as span the interval with different verses.

Because both song and mantra are activities in which groups of people often participate, when music or mantra incorporating breathing cues is utilized the heart rate variability cycles of participants are synchronized. This is a nascent field of investigation about which much will be learned via the application of the present invention.

A discussion of visual presentation methods will now ensue. A similar requirement exists for visual indicators as for audio indicators, that is, it is desirable that the visual indicator communicate as much information as is possible about the 5.9 second cycle to the user. This includes changes from inhalation to exhalation and visa versa, whether the phase is an inhalation phase or an exhalation phase, and progression of the 5.9 second interval. Visual indicators may work alone or in combination with audible presentation methods previously described.

Referring to FIG. 5, the most basic method is represented by 51 which is a simple indication of change of breathing

phase, that is, the change from inhalation to exhalation or visa versa. During the inhalation phase, indicator 52 is highlighted, during the exhalation phase indicator 53 is highlighted.

FIG. 6 presents a 13 segment indicator 61 that denotes the change of cycle, the present phase of the cycle, that is, inhalation or exhalation, and progression of the cycle. Inhalation is indicated by the transition from 1 to 7, exhalation is indicated by the transition from 7 to 1. It employs the 7 stage convention as did audio examples 2E and 2F. A second convention is applied to this visual display, this being the association of specific colors with specific numeric stages of progression. This association is depicted in the table 64. Each segment of display 61 is illuminated for  $\frac{1}{13}$ th of the fundamental 5.9 second period or 0.45 seconds. Because numbers 1, 62, and 7, 63, are representative of both the end of the inhalation phase and the beginning of the exhalation phase, they are highlighted for 2 consecutive beats.

Referring to FIG. 7, these conventions and their relevance to breathing and heart rate variability will now be discussed. Preferred audible and visual embodiments of the present invention employ the 7 stage convention with inhalation occurring on increasing number and exhalation occurring on decreasing number. The 7 stage convention conforms to traditional yogic theory of energy planes or centers that exist in the body. When a subject employs the prescribed breathing method, that is synchronization of their breathing cycle with an external timing reference that is tuned to the natural heart rate variability cycle, the heart rate variability cycle will synchronize with the breathing cycle. When a subject practices this technique for a period of time, there is an internal perception that the energy in the body progresses to these different centers in a fashion consistent with the cycle of breath. That is, as inhalation occurs 71, the energy moves from the lowermost center of the body, corresponding to the number 1, 73, to the uppermost center of the body corresponding to the number 7, 74 via display segments 2, 3, 4, 5 and 6. As exhalation occurs 72, the energy moves from the uppermost center of the body corresponding to the number 7, 74, to the lowermost center of the body corresponding to the number 1, 73 via display segments 8, 9, 10, 11, and 12. As this begins to happen, this energy movement and its location in the body becomes an important dimension of the perceived progression of the breathing cycle. A consistent association of color with number is applied to this display according to table 75. Relative to this specific display, there are 13 segments, 5 of which are paired.

Referring to FIGS. 8, 81 and 82 are simply circular representations of a 7 segment indicator. Sectors are sequentially highlighted from 1 to 7 and 7 to 1. 81 demonstrates the inhalation phase of the cycle and 82 demonstrates the exhalation phase of the cycle. That is, as inhalation occurs 81, the energy moves from the lowermost center of the body, corresponding to the number 1, to the uppermost center of the body corresponding to the number 7. Each sector is illuminated for  $\frac{1}{7}$ th of the fundamental 5.9 second period or 0.84 seconds. A consistent association of color and number is applied to this display according to table 83.

As in the case of music or mantra being engaged in simultaneously by multiple participants resulting in group synchronization of the heart rate variability cycle, the same applies to any form of the invention in which a group can participate including audible and visual forms. These might include school rooms, board rooms, concert halls, etc. This might also include wide area groups including local, regional, national, and global participation via television, internet, and radio broadcast. Again, as this is a nascent field

of investigation much will be learned in this regard via the application of the present invention.

What is claimed:

1. A method of presenting audible and visual cues to a human for synchronizing a breathing cycle with an external timing reference for purposes of synchronizing a heart rate variability cycle with the breathing cycle, thereby achieving coherence of the heart rate variability cycle, comprising:

a) generating a human perceptible indication to identify inhalation phases and exhalation phases of the breathing cycle, changes between said inhalation and exhalation phases, progression of said inhalation and exhalation phases in time, and progression of said inhalation phases and exhalation phases relative to a period of time having a combination of the inhalation phases and exhalation phases, the combination having a center frequency of approximately 11.76 seconds, wherein the period having the center frequency of approximately 11.76 seconds represents a nominal heart rate variability cycle; and

b) instructing the human to align the breathing cycle with the generated human perceptible indication to synchronize the breathing cycle with the heart rate variability cycle to achieve coherence of the heart rate variability cycle,

wherein generating the human perceptible indication comprises generating an audible indicator by adjusting a musical tempo associated with a music score and incorporating the audible indicator into the music score.

2. A method of presenting audible and visual cues to a human for synchronizing a breathing cycle with an external timing reference for purposes of synchronizing a heart rate variability cycle with the breathing cycle, thereby achieving coherence of the heart rate variability cycle, comprising:

a) generating a human perceptible indication to identify inhalation phases and exhalation phases of the breathing cycle, changes between said inhalation and exhalation phases, progression of said inhalation and exhalation phases in time, and progression of said inhalation phases and exhalation phases relative to a period of time having a combination of the inhalation phases and exhalation phases, the combination having a center frequency of approximately 11.76 seconds, wherein the period having the center frequency of approximately 11.76 seconds represents a nominal heart rate variability cycle; and

b) instructing the human to align the breathing cycle with the generated human perceptible indication to synchronize the breathing cycle with the heart rate variability cycle to achieve coherence of the heart rate variability cycle,

wherein generating the human perceptible indication comprises generating an audible indicator including an audible signal recitation of numbers 1 through 7 sequentially within the period having the center frequency of approximately 11.76 seconds, 1 to 7 denoting the inhalation phases and 7 to 1 denoting the exhalation phases.

3. A method of presenting audible and visual cues to a human for synchronizing a breathing cycle with an external timing reference for purposes of synchronizing a heart rate variability cycle with the breathing cycle, thereby achieving coherence of the heart rate variability cycle, comprising:

a) generating a human perceptible indication to identify inhalation phases and exhalation phases of the breathing cycle, changes between said inhalation and exha-

lation phases, progression of said inhalation and exhalation phases in time, and progression of said inhalation phases and exhalation phases relative to a period of time having a combination of the inhalation phases and exhalation phases, the combination having a center frequency of approximately 11.76 seconds, wherein the period having the center frequency of approximately 11.76 seconds represents a nominal heart rate variability cycle; and

b) instructing the human to align the breathing cycle with the generated human perceptible indication to synchronize the breathing cycle with the heart rate variability cycle to achieve coherence of the heart rate variability cycle,

wherein generating the human perceptible indication comprises generating an audible indicator by generating an audible signal including musical cues and incorporating the musical cues into musical scores at approximately 5.88 second intervals to identify the changes of the inhalation and exhalation phases of the breathing cycle.

4. A method of presenting audible and visual cues to a human for synchronizing a breathing cycle with an external timing reference for purposes of synchronizing a heart rate variability cycle with the breathing cycle, thereby achieving coherence of the heart rate variability cycle, comprising:

a) generating a human perceptible indication to identify inhalation phases and exhalation phases of the breathing cycle, changes between said inhalation and exhalation phases, progression of said inhalation and exhalation phases in time, and progression of said inhalation phases and exhalation phases relative to a period of time having a combination of the inhalation phases and exhalation phases, the combination having a center frequency of approximately 11.76 seconds, wherein the period having the center frequency of approximately 11.76 seconds represents a nominal heart rate variability cycle; and

b) instructing the human to align the breathing cycle with the generated human perceptible indication to synchronize the breathing cycle with the heart rate variability cycle to achieve coherence of the heart rate variability cycle,

wherein generating the human perceptible indication comprises generating a vertically oriented 13 segment visual indicator to identify the inhalation phases and the exhalation phases of the breathing cycle, the changes of the inhalation and exhalation phases, the progression of the inhalation and exhalation phases in time, and progression of the inhalation phases and the exhalation phases relative to the period having the center frequency of approximately 11.76 seconds.

5. A method of presenting audible and visual cues to a human for synchronizing a breathing cycle with an external timing reference for purposes of synchronizing a heart rate variability cycle with the breathing cycle, thereby achieving coherence of the heart rate variability cycle, comprising:

a) generating a human perceptible indication to identify inhalation phases and exhalation phases of the breathing cycle, changes between said inhalation and exhalation phases, progression of said inhalation and exhalation phases in time, and progression of said inhalation phases and exhalation phases relative to a period of time having a combination of the inhalation phases and exhalation phases, the combination having a center frequency of approximately 11.76 seconds, wherein the

period having the center frequency of approximately 11.76 seconds represents a nominal heart rate variability cycle; and

b) instructing the human to align the breathing cycle with the generated human perceptible indication to synchronize the breathing cycle with the heart rate variability cycle to achieve coherence of the heart rate variability cycle,

wherein generating the human perceptible indication comprises generating a visual indicator including a circular 7 sector visual indicator to identify the inhalation phases and the exhalation phases of the breathing cycle, the changes of the inhalation and exhalation phases, the progression of the inhalation and exhalation phases in time, and the progression of the inhalation phases and the exhalation phases relative to the period having the center frequency of approximately 11.76 seconds.

6. A method of presenting audible and visual cues to a human for synchronizing a breathing cycle with an external timing reference for purposes of synchronizing a heart rate variability cycle with the breathing cycle, thereby achieving coherence of the heart rate variability cycle, comprising:

a) generating a human perceptible indication to identify inhalation phases and exhalation phases of the breathing cycle, changes between said inhalation and exhalation phases, progression of said inhalation and exhalation phases in time, and progression of said inhalation phases and exhalation phases relative to a period of time having a combination of the inhalation phases and exhalation phases, the combination having a center frequency of approximately 11.76 seconds, wherein the period having the center frequency of approximately 11.76 seconds represents a nominal heart rate variability cycle; and

b) instructing the human to align the breathing cycle with the generated human perceptible indication to synchronize the breathing cycle with the heart rate variability cycle to achieve coherence of the heart rate variability cycle,

wherein generating the human perceptible indication comprises generating a visual indicator including a 14 stage vertically oriented elliptical indicator to identify the inhalation phases and the exhalation phases of the breathing cycle, the changes of the inhalation and exhalation phases, the progression of the inhalation and exhalation phases in time, and the progression of the inhalation phases and the exhalation phases relative to the period having the center frequency of approximately 11.76 seconds.

7. A method of presenting audible and visual cues to a human for synchronizing a breathing cycle with an external timing reference for purposes of synchronizing a heart rate variability cycle with the breathing cycle, thereby achieving coherence of the heart rate variability cycle, comprising:

a) generating a human perceptible indication to identify inhalation phases and exhalation phases of the breathing cycle, changes between said inhalation and exhalation phases, progression of said inhalation and exhalation phases in time, and progression of said inhalation phases and exhalation phases relative to a period of time having a combination of the inhalation phases and exhalation phases, the combination having a center frequency of approximately 11.76 seconds, wherein the period having the center frequency of approximately 11.76 seconds represents a nominal heart rate variability cycle; and

b) instructing the human to align the breathing cycle with the generated human perceptible indication to synchronize the breathing cycle with the heart rate variability cycle to achieve coherence of the heart rate variability cycle,

wherein generating the human perceptible indication comprises an audible indicator and a visual indicator including indications of numbers 1 through 7 sequentially within the period having the center frequency of approximately 11.76 seconds, 1 to 7 denoting the inhalation phases and 7 to 1 denoting the exhalation phases.

8. A method of presenting audible and visual cues to a human for synchronizing a breathing cycle with an external timing reference for purposes of synchronizing a heart rate variability cycle with the breathing cycle, thereby achieving coherence of the heart rate variability cycle, comprising:

a) generating a human perceptible indication to identify inhalation phases and exhalation phases of the breathing cycle, changes between said inhalation and exhalation phases, progression of said inhalation and exhalation phases in time, and progression of said inhalation phases and exhalation phases relative to a period of time having a combination of the inhalation phases and exhalation phases, the combination having a center frequency of approximately 11.76 seconds, wherein the period having the center frequency of approximately 11.76 seconds represents a nominal heart rate variability cycle; and

b) instructing the human to align the breathing cycle with the generated human perceptible indication to synchronize the breathing cycle with the heart rate variability cycle to achieve coherence of the heart rate variability cycle,

wherein generating the human perceptible indication comprises generating an audible indicator including a frequency modulated tone and a recitation of numbers 1 through 7 and wherein instructing the human to align the breathing cycle with the audible indicator includes instructing the human so that inhalation occurs coincident with increasing frequency of the frequency modulated tone and increasing number and exhalation occurs coincident with decreasing frequency of the frequency modulated tone and decreasing number.

9. A method of presenting audible and visual cues to a human for synchronizing a breathing cycle with an external timing reference for purposes of synchronizing a heart rate variability cycle with the breathing cycle, thereby achieving coherence of the heart rate variability cycle, comprising:

a) generating a human perceptible indication to identify inhalation phases and exhalation phases of the breathing cycle, changes between said inhalation and exhalation phases, progression of said inhalation and exhalation phases in time, and progression of said inhalation phases and exhalation phases relative to a period of time having a combination of the inhalation phases and exhalation phases, the combination having a center frequency of approximately 11.76 seconds, wherein the period having the center frequency of approximately 11.76 seconds represents a nominal heart rate variability cycle; and

b) instructing the human to align the breathing cycle with the generated human perceptible indication to synchronize the breathing cycle with the heart rate variability cycle to achieve coherence of the heart rate variability cycle,

**11**

wherein generating the human perceptible indication comprises generating an audible indicator by post processing at least one existing musical recording to shorten or lengthen a musical tempo associated with the at least one existing musical recording to accommodate

**12**

the period having the center frequency of approximately 11.76 seconds and the insertion of the audible indicator approximately every 5.88 seconds.

\* \* \* \* \*

专利名称(译)	为了使心率变异性循环与呼吸循环同步的目的，呈现用于使呼吸循环与外部定时参考同步的听觉和视觉提示的方法		
公开(公告)号	<a href="#">US7255672</a>	公开(公告)日	2007-08-14
申请号	US10/802456	申请日	2004-03-18
[标]申请(专利权)人(译)	ELLIOTT斯蒂芬乙		
申请(专利权)人(译)	ELLIOTT斯蒂芬乙		
当前申请(专利权)人(译)	相干LLC		
[标]发明人	ELLIOTT STEPHEN BENNETT		
发明人	ELLIOTT, STEPHEN BENNETT		
IPC分类号	A61M21/00 A61B5/00 A61B5/02 A61B5/0205 A61B5/024 A61B5/04 A61B5/08		
CPC分类号	A61B5/02405 A61B5/486 A61B5/0205 A61B5/024 A61B5/0816		
其他公开文献	US20050209503A1		
外部链接	<a href="#">Espacenet</a> <a href="#">USPTO</a>		

摘要(译)

本发明包括一种提供听觉和视觉提示的广泛方法，用于使呼吸循环与外部定时参考同步，以使心率变异性循环与呼吸循环同步，从而实现心率变异性循环的一致性。一系列听觉和视觉指示器被指定用于通信呼吸阶段，呼吸阶段的改变，阶段内的时间的进展，以及相对于从业者的内部感知的阶段的进展。

