



(19) **United States**

(12) **Patent Application Publication**
Pernu et al.

(10) **Pub. No.: US 2013/0131484 A1**

(43) **Pub. Date: May 23, 2013**

(54) **SNAP AND ELECTRODE ASSEMBLY FOR A HEART RATE MONITOR BELT**

Publication Classification

(71) Applicant: **SUUNTO OY**, Vantaa (FI)

(51) **Int. Cl.**

A61B 5/0245 (2006.01)
A61B 5/00 (2006.01)
A61B 5/0408 (2006.01)
A61B 5/0416 (2006.01)

(72) Inventors: **Kimmo Pernu**, Vantaa (FI); **Tapio Selby**, Vantaa (FI); **Phillip Lindberg**, Helsinki (FI); **Jukka Manni**, Helsinki (FI); **Jorma Liljemark**, Jarvenpaa (FI); **Tapio Savolainen**, Helsinki (FI); **Hannu Putkinen**, Helsinki (FI); **Jari Akkila**, Helsinki (FI); **Satu Rahkonen**, Espoo (FI); **Erik Lindman**, Vantaa (FI)

(52) **U.S. Cl.**

CPC *A61B 5/0245* (2013.01); *A61B 5/0416* (2013.01); *A61B 5/6831* (2013.01); *A61B 5/04085* (2013.01); *A61B 5/6804* (2013.01)
USPC **600/388**; 600/390

(73) Assignee: **SUUNTO OY**, Vantaa (FI)

(21) Appl. No.: **13/731,152**

(57) **ABSTRACT**

(22) Filed: **Dec. 31, 2012**

Related U.S. Application Data

(63) Continuation-in-part of application No. 11/808,391, filed on Jun. 8, 2007, now Pat. No. 8,386,009.

The present invention relates generally to a thin, low thickness snap integrated within or built within a heart rate monitor belt or snap and electrode assembly. The snap can be integrated or built directly in to a heart rate monitor belt. Furthermore, the heart rate monitor belt can be integrated within a textile or garment, for example a compression shirt, sports bra or cycling shorts. The snap can be flushly integrated into the belt or garment such the snap does not take away from the general wearability of the heart rate monitor belt or garment.

Foreign Application Priority Data

Jun. 8, 2006 (FI) 20065391

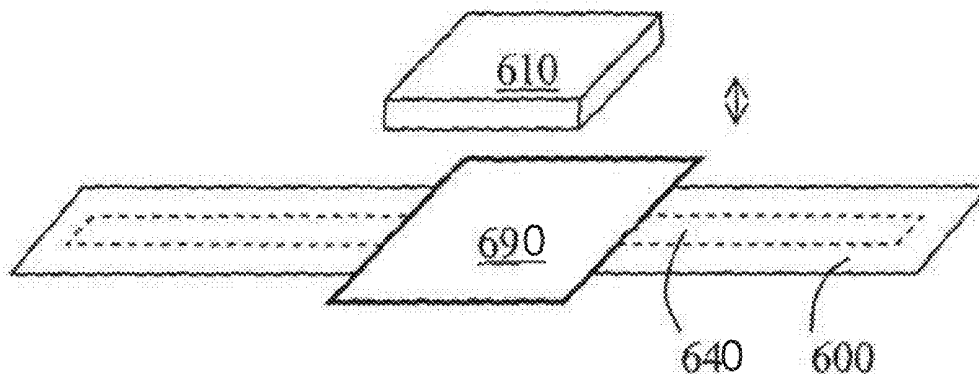

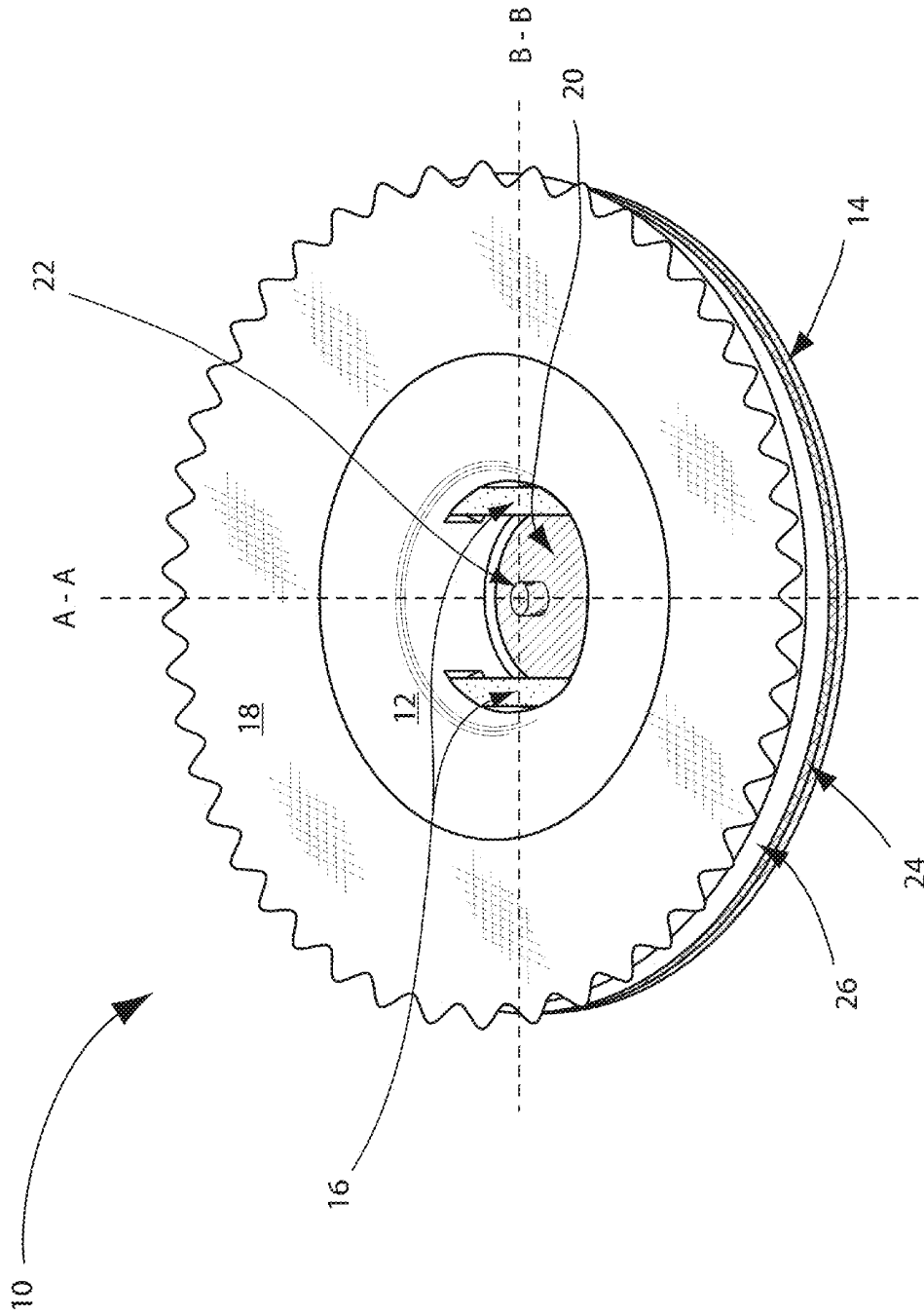

Fig. 1

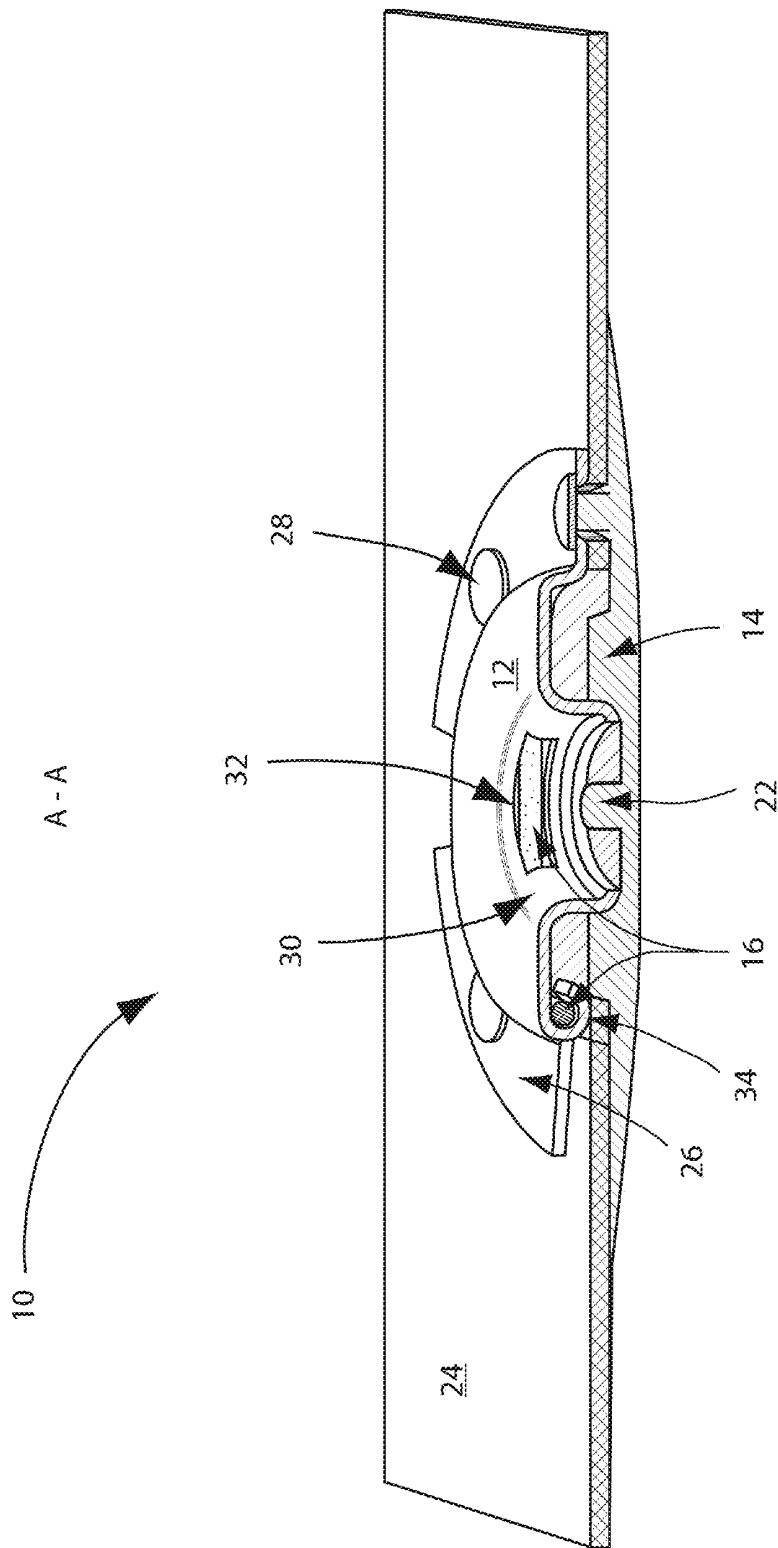

Fig. 2

B - B

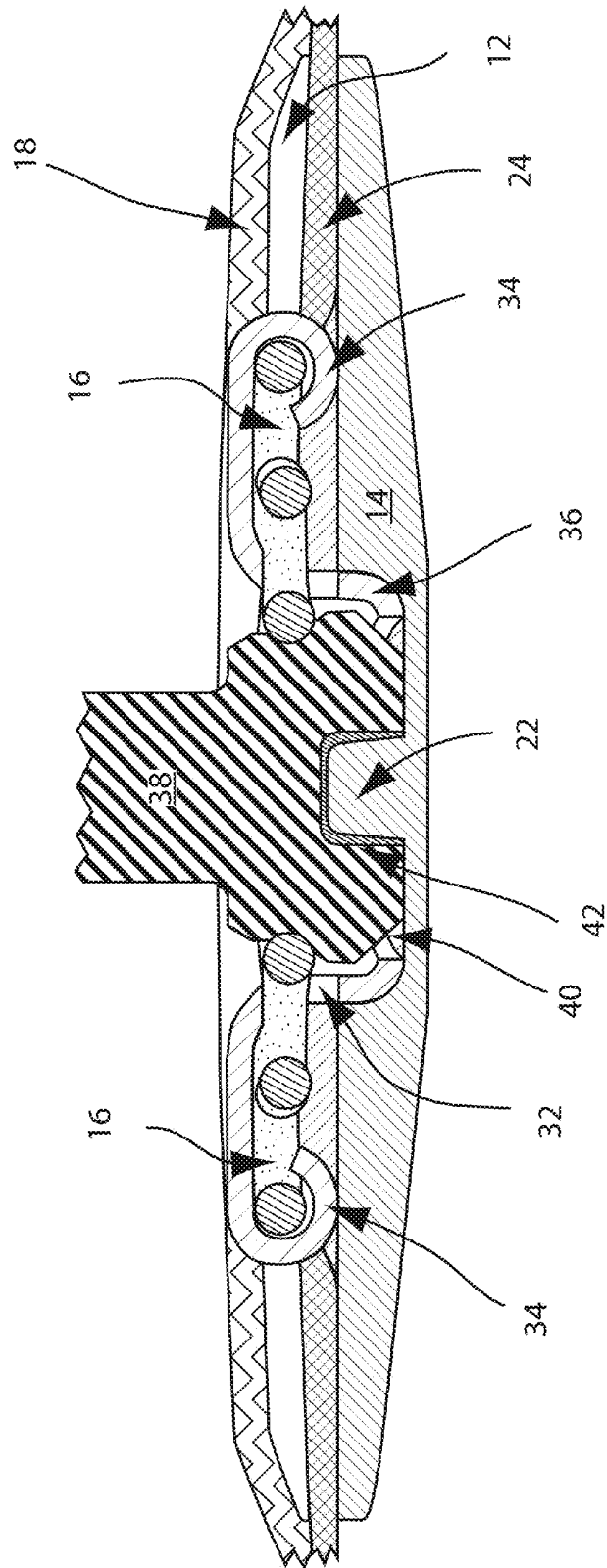

Fig. 3

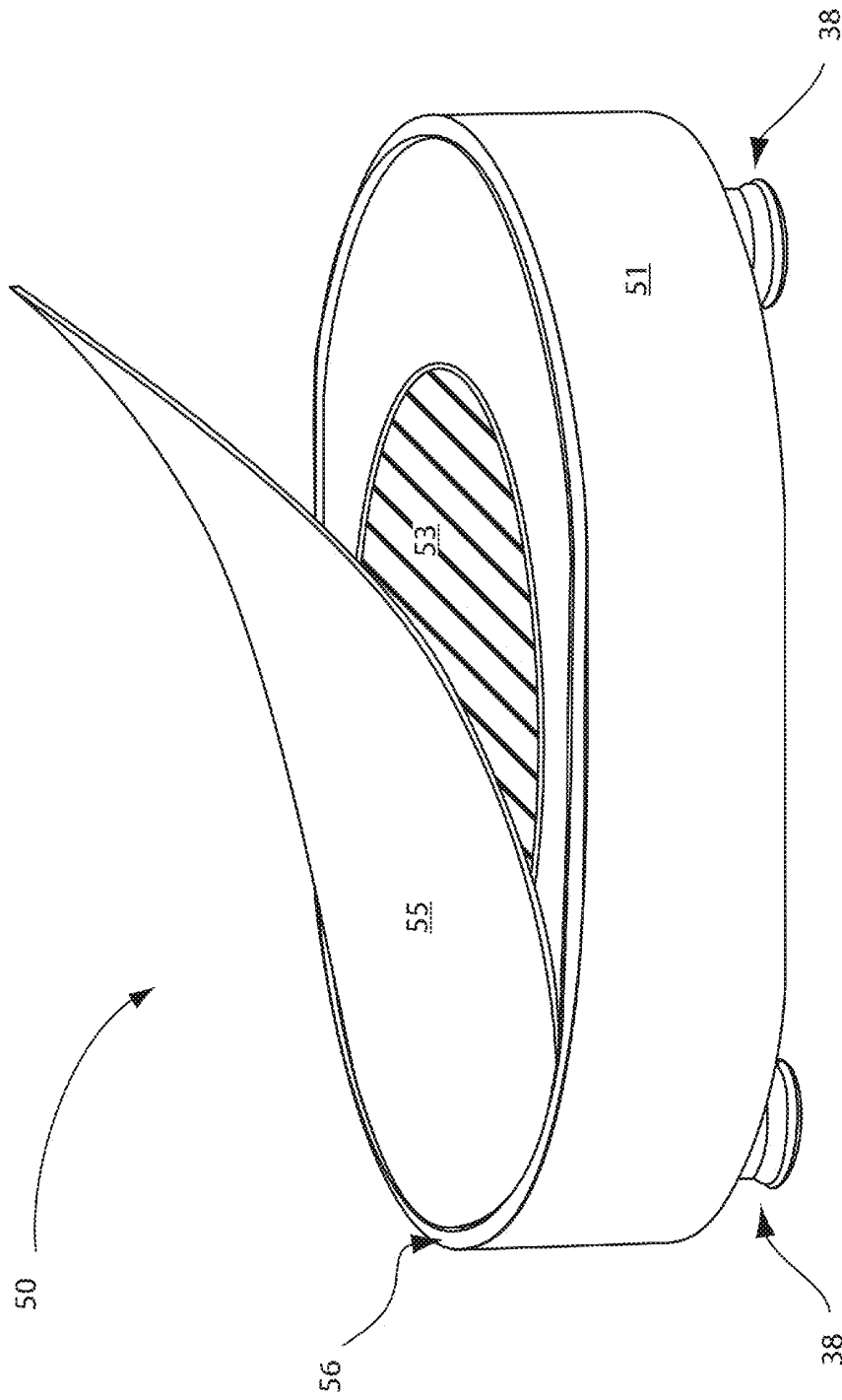

Fig. 4

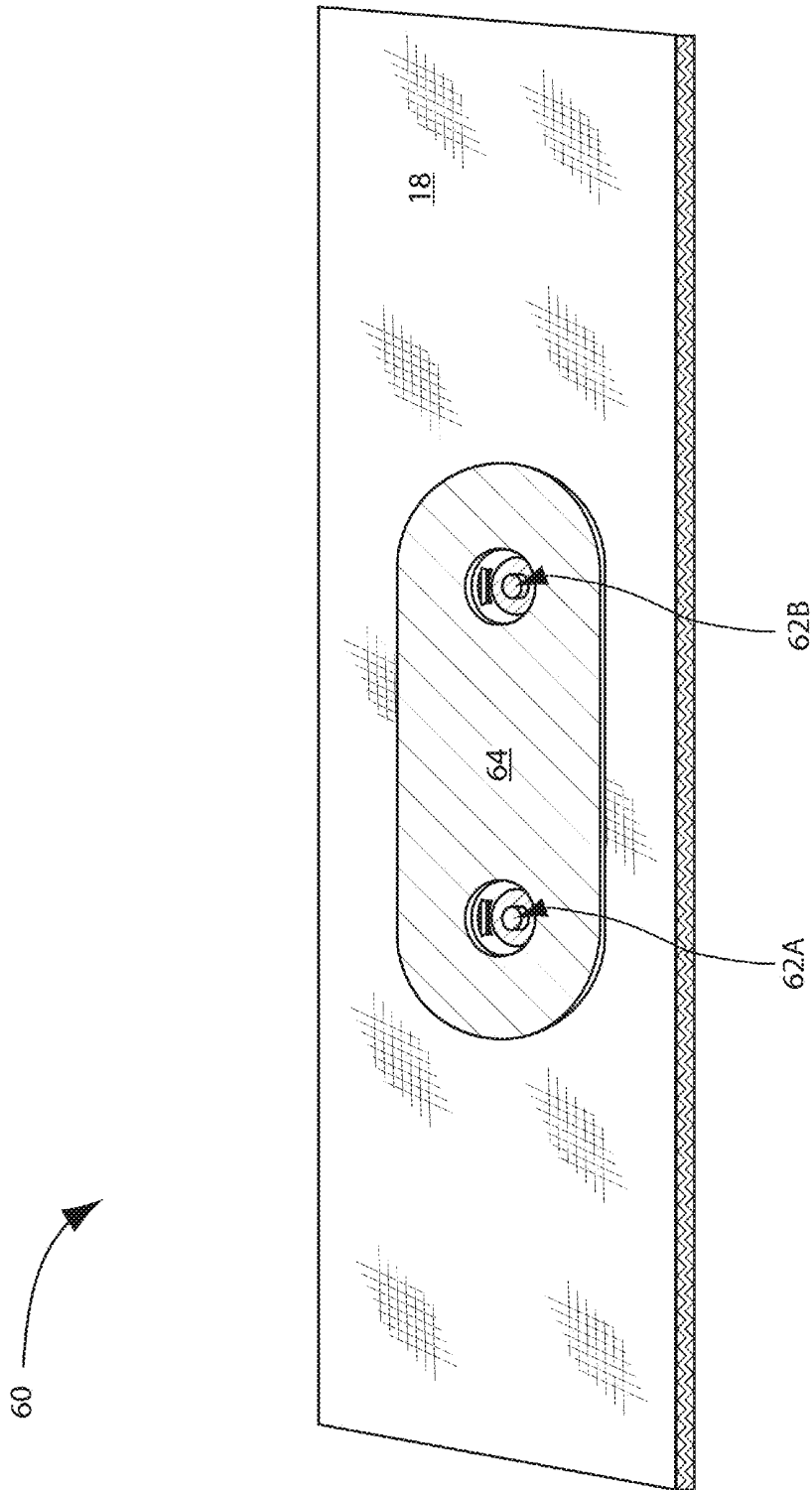

Fig. 5

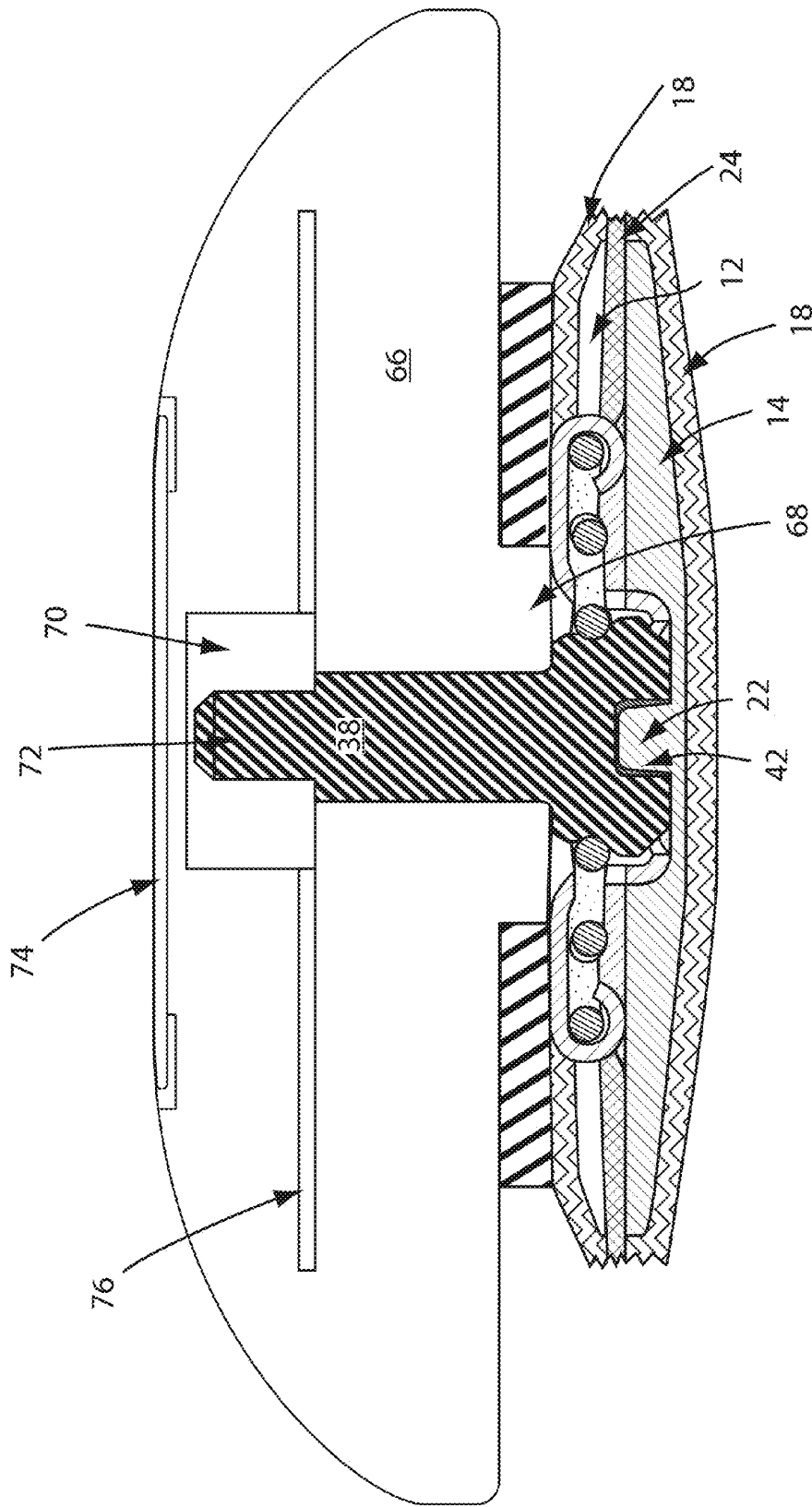

Fig. 6

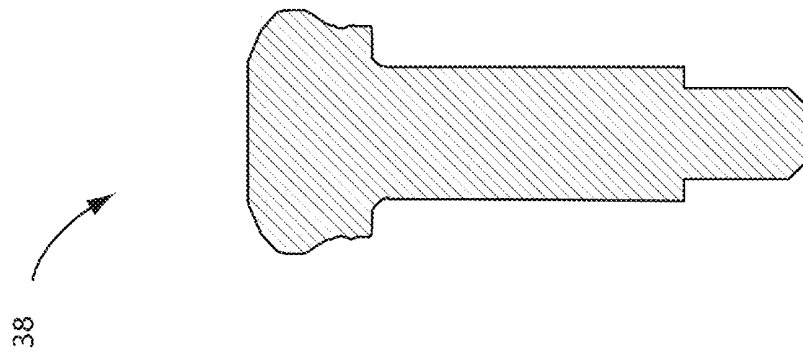

Fig. 7c

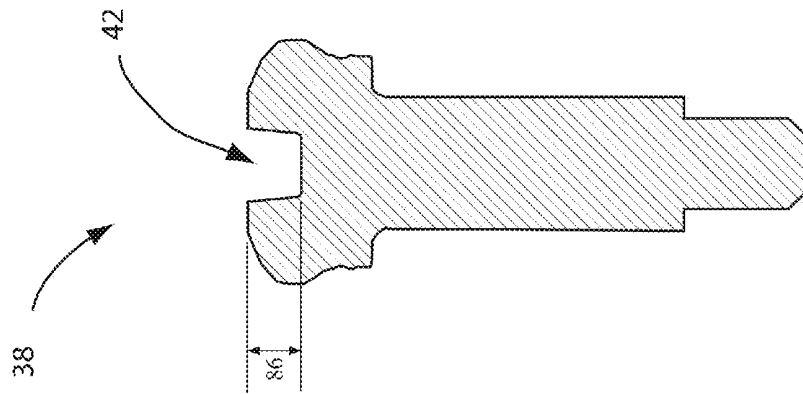

Fig. 7b

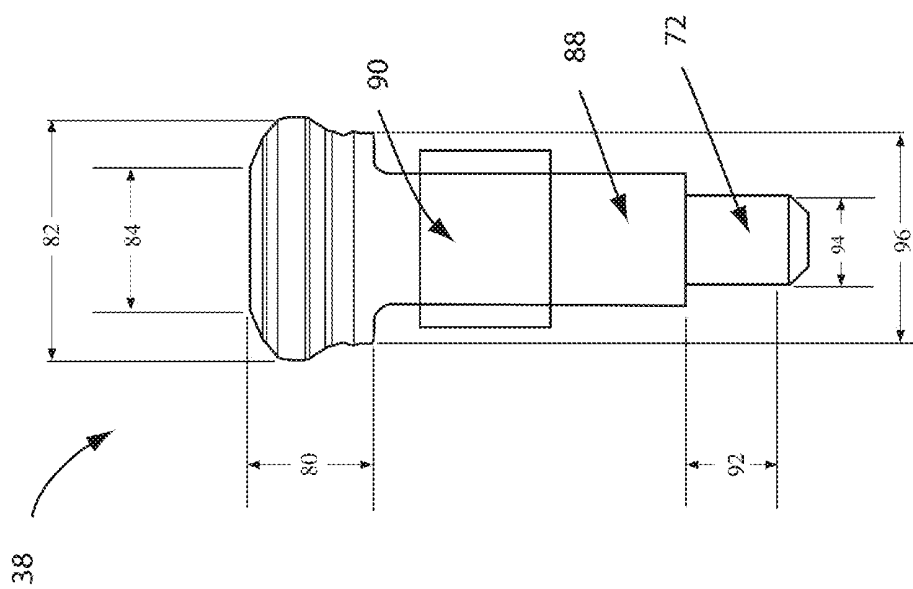

Fig. 7a

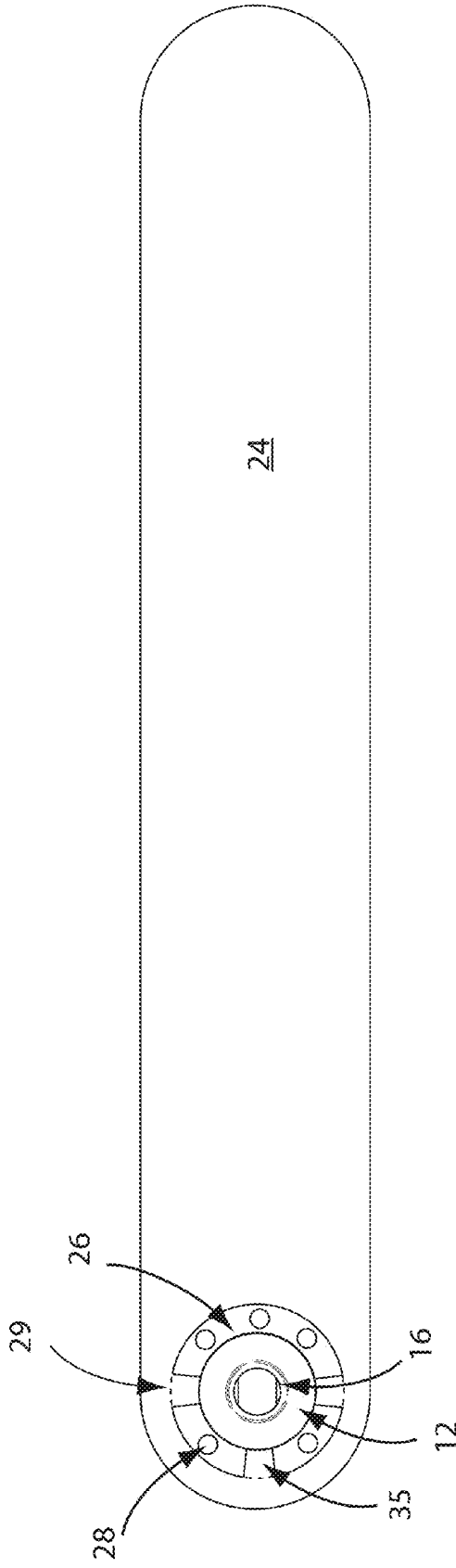

Fig. 8

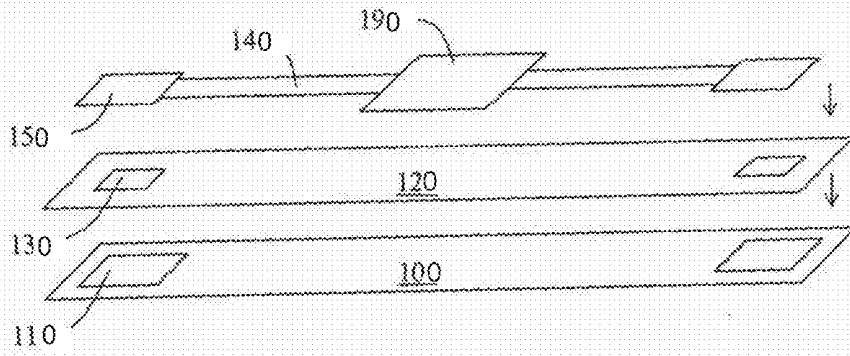

Fig. 9

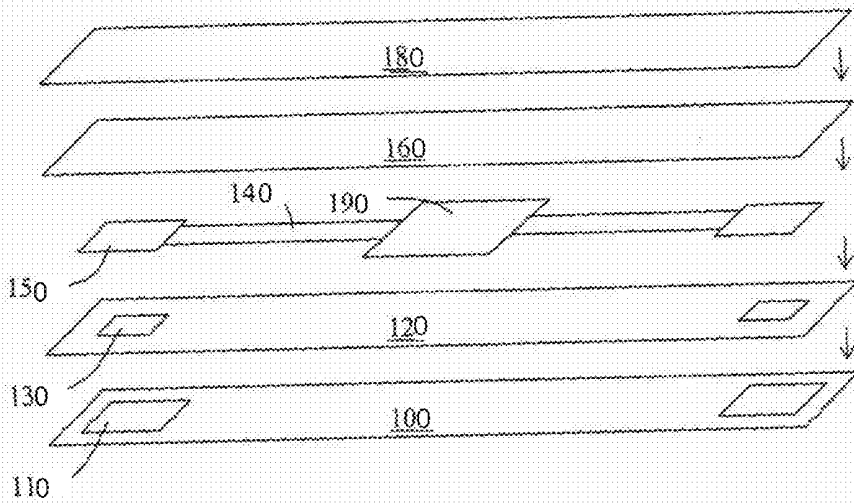

Fig. 10a

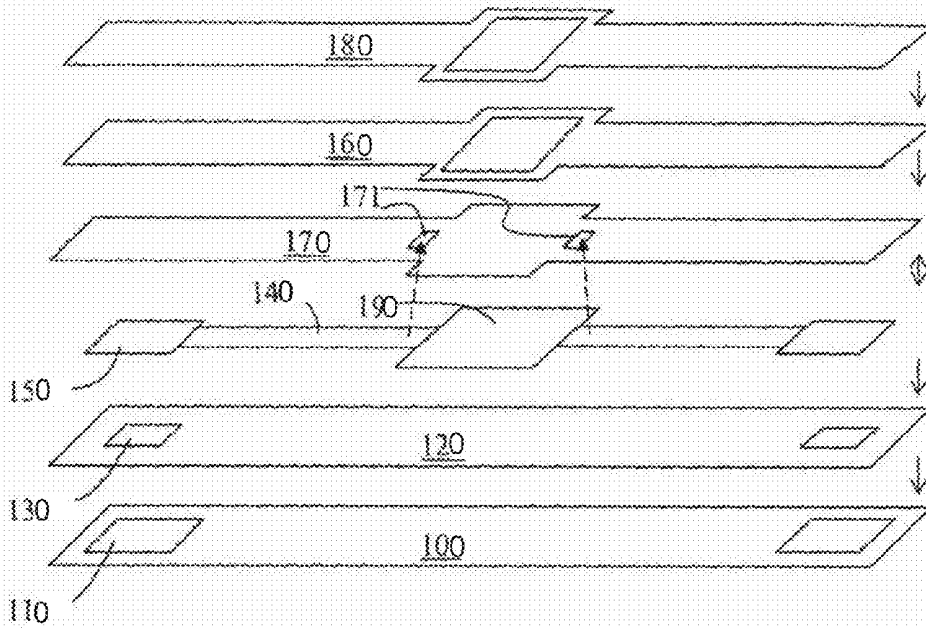

Fig. 10b

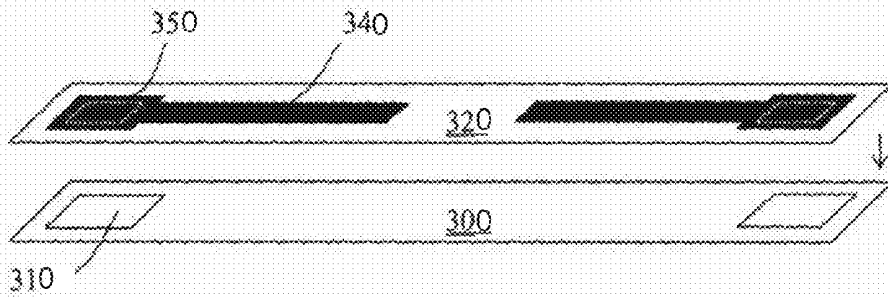

Fig. 11

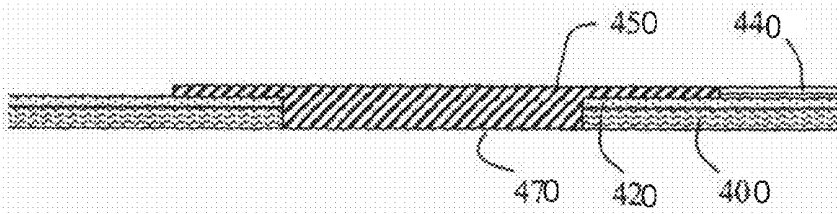

Fig. 12a

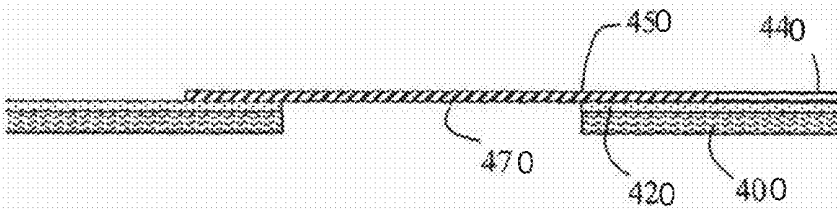

Fig. 12b

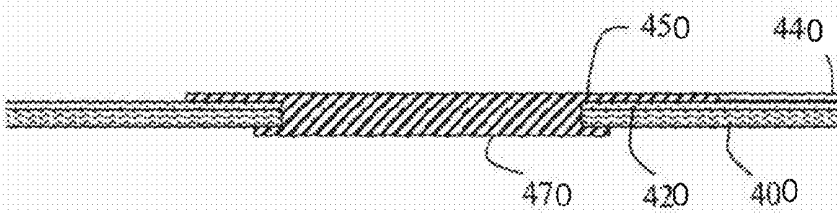

Fig. 12c

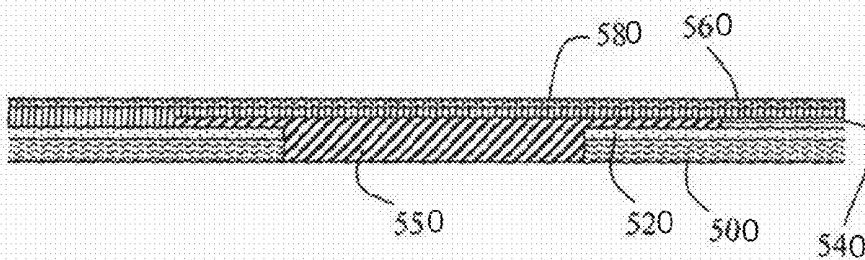

Fig. 13

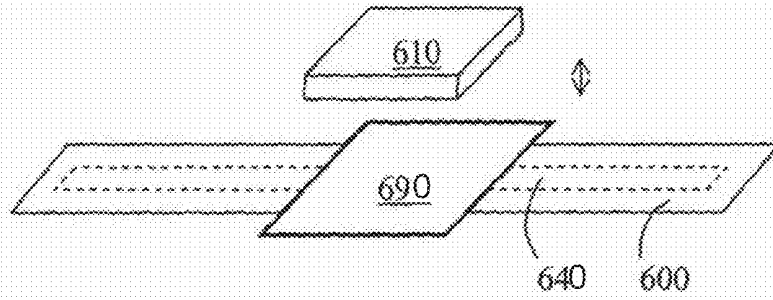

Fig. 14

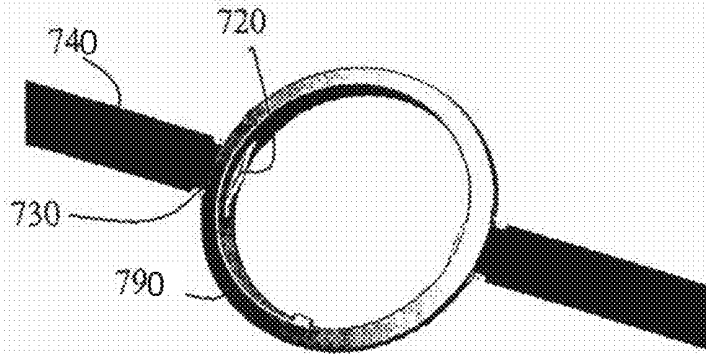

Fig. 15

SNAP AND ELECTRODE ASSEMBLY FOR A HEART RATE MONITOR BELT

FIELD OF INVENTION

[0001] The present invention relates generally to a snap and electrode assembly for use in a heart rate monitor belt. More particularly, embodiments of the present snap are particularly well suited for receiving, holding and enabling an electrical connection with a male end of a telemetric device. Examples of the present snap and electrode assembly are integrated within a heart rate monitor belt.

BACKGROUND OF THE INVENTION

[0002] Traditional heart-rate meter heart rate bands and heart rate belts generally comprise a body made of plastic, on the surface of which there are two local electrodes to be placed against the chest. Electronics for transmitting a heart rate signal, typically to a wristop device, are built into the plastic body. Conductors from the electrodes to the electronics also run inside the body, which is generally attached against the chest with the aid of a flexible band.

[0003] Because plastic heart rate bands are relatively thick and can feel uncomfortable in use, heart rate belts and sensory utilizing textile materials in particular have been developed recently. One such is disclosed in WO publication 2005/032366. In the solution depicted in it, the electrodes and transmission conductors are surfaced with a conductive material directly in the textile material. The transmission conductors can afterwards be coated with an insulating material, so that only the electrodes remain in contact with the skin and the quality of the signal improves. However, the laminate then remains on the surface of the product at the conductors, so that the breathability of these locations is reduced and they may feel uncomfortable against the skin.

[0004] WO publication 2002/071935 (FI 110925) discloses a heart rate sensor, in which there are electrodes containing conductive fibres, at the ends of which there is a moisture-retaining layer to improve the electrical contact of the electrodes with the skin. This solution also has a problem with the placing of the signal transmission conductors relative to the fibre material, particularly with creating both reliable contacts with the electrodes for them and good electrical insulation.

[0005] WO publication 2003/082103 discloses a heart rate sensor, with electrodes made by moulding through a textile material. The electrical conductors can be added to the mould, in order to attach them securely to the electrode moulding. However, the electrical conductors remain loose of the surface of the fabric and liable to mechanical stresses acting on them. They can also be attached as part of the textile with the aid of thermo-compression, but then a powerful interference signal may connect to them from the skin through the fabric.

[0006] WO publication 2005/0043641 discloses a device intended to measure heart rate, which can be detachably attached to a flexible band, or piece of apparel, with the aid of hooks in it. Though it can be attached to many different pieces of apparel, it does not eliminate the problem of discomfort when using traditional heart rate bands.

[0007] Currently, there are heart rate monitor belts which people can wear underneath their clothing in order to monitor their heart rate. Such belts are typically designed such that a telemetric transmitter is detachably connected to a belt having two electrodes which are in contact with the user's skin in

the chest region of the user's torso. The electrodes identify an electric ECG pulse caused by the heart and then the detachable telemetric transmitter transmits data indicative of the user's heart beat with the use of wireless magnetic near field communication or a radio signal to a remote receiver provided with a display. In many instances the remote receiver is provided in the form of a wrist watch, wrist top computer or other similar display carried by a user, typically on the user's wrist.

[0008] Since various acceleration and magnetic sensors can be integrated in small and lightweight devices, the telemetric data to be transferred may, instead of or in addition to the heart rate, comprise a plurality of measured variable data, such as working frequency, pedaling rate and pedaling frequency, travel speed, etc. The data to be transferred may additionally comprise data required for the identification of the user and/or the transmitter device.

[0009] U.S. application No. 11/808,391 filed Jun. 8, 2007 and published as US 2007/0285868 which is herein incorporated by reference in its entirety, for instance, discloses a heart rate monitor belt which comprises a plurality of electrodes and a detachable telemetric transmitter.

[0010] It is preferably to have a telemetric transmitter which is detachable from a heart rate monitor belt for several reasons. From a consumer point of view, a user is typically sweating while using a heart rate monitor belt and it is therefore advantageous to be able to separate the electronic telemetric transmitter from the belt so that the belt can be washed. From a manufacturing point of view, the process for manufacturing the belt is substantially different from that of manufacturing the transceiver and therefore it is beneficial to be able to manufacture the components separately. Additionally, it is beneficial for one telemetric transmitter to be interchangeable with a plurality of belts.

[0011] Though there are several alternative methods for detachably connecting a telemetric transmitter to a heart rate monitor belt, the industry has almost entirely adopted the use of a pair of standard garment snaps. These standard garment snaps typically are mounted on the material of a heart rate monitor belt and virtually their entire thickness of around 4 mm protrudes from the outer surface of the belt.

[0012] Due to the existing technology and methods for detachably connecting telemetric transmitters it has not been realistic to incorporate heart rate monitor electrodes in to typical garments. In fact, the primary road block to such incorporation has been the size and bulkiness of the standard garment snaps. No clothing manufacture, nor consumer, has wanted 4 mm protrusions from their garments such as tops, shirts and sports bras.

[0013] Therefore, the garment industry has incurred a long felt need for an improved method of detachably connecting a telemetric transmitter to an article of clothing which does not compromise the integrity and utility of the underlying garment. However, the telemetric transmitter manufacturing industry has already adopted certain standards which relate to the use of a pair of male studs on a telemetric transmitter to be detachably snapped in to a pair of snaps on a heart rate monitor belt. As such, it would not be economical to wholly redesign the male portions of telemetric transmitters and the method in which they connect to an object having the necessary electrodes for measuring a user's heart rate.

[0014] Thus, there exists a need for a snap which fulfils the requirements of the garment industry but which fits in at least partially with the existing standards of the telemetric trans-

mitter manufacturing industry. However, several critical issues arise when attempting to merely minimize the existing standardized snap. The main issue is the integrity of the connection between the male stud and the snap. Any amount over movement of the male stud within the snap will create electrical noise which makes difficult to accurately measure parameters such as a user's heart beat. Additionally, as a user is typically involved in strenuous activity while utilizing the product, the connection needs to withstand, and support the telemetric transmitter during such activity. As the depth of the snap decreases, the forces required to insure a reliably stable connection significantly increase.

[0015] Further yet, users typically sweat while undergoing strenuous activity wearing the product. As a reliable electrical connection is necessary between the telemetric transmitter and the electrode on the user's skin, it is important to keep the connection moisture free to reduce the likelihood of any shorts. Similarly, the problem is compounded for users who wish to utilize a heart rate monitor under water, for example while swimming or diving.

[0016] Therefore, there exist numerous challenges in the art to the development of a means of detachably connecting a telemetric transmitter to a garment having electrodes for monitoring a user's heart beat which aims to satisfy user's need, the garment manufacturer's needs and the needs of telemetric transmitter manufactures.

SUMMARY OF THE INVENTION

[0017] It is an object of certain embodiments of the present invention to provide a snap and electrode assembly which can be a standalone assembly and/or integrateable with, integrated with and/or built in to a heart rate monitor belt. The snap of the assembly can generally be for receiving, holding and enabling an electrical connection with a male end of an electronic device.

[0018] It is an aspect of certain of such embodiments that the snap and electrode assembly comprises an upper cap portion having a recess forming at least a portion of the sides of a socket region of a snap for receiving a male end of an electronic device, a base portion coupled to the upper cap portion and forming at least a portion of a channel between the base portion and the upper cap portion around the periphery of the socket region, a conductive wire spring housed at least partially within the gap for releasably holding the male end of the electronic device within a socket region of the snap, and an electrode. The snap and electrode assembly can further comprise an upper cap portion having an outer flange region which at least partially surrounds the recess, a snap further comprising at least one means of mechanically coupling the wire spring to the snap, and an electrode being held between at least the outer flange region of the upper cap portion and the base portion and is electrically connected to at least the conductive wire spring.

[0019] Still yet, it is an object of certain embodiments of the present invention to provide a heart rate monitor belt and/or EMG monitor belt.

[0020] It is an aspect of certain of said embodiments for a monitor belt to comprise at least one material layer, two electrodes coupled to the at least one material layer, said electrodes arranged to detect the heart rate of a human or animal wearing the heart rate monitor belt, and a separate snap coupled to each of said electrodes, each of said snaps configured to receive, hold and enable an electrical connec-

tion to a male end of an electronic device. Each snap may be integrated within or built within the monitor belt and each snap may further comprise an upper cap portion having a recess forming at least a portion of the sides of a socket region of a snap for receiving a male end of a telemetric device, a base portion coupled to the upper cap portion and forming at least a portion of a channel between the base portion and the upper cap portion around the periphery of the socket region, a conductive wire spring housed at least partially within the gap for releasably holding the male end of a telemetric device within a socket region of the snap, and the upper cap portion further comprises an outer flange region which at least partially surrounds the recess, the snap comprises at least one means of mechanically coupling the wire spring to the snap, and the electrode is held between at least the outer flange region of the upper cap portion and the base portion and is electrically connected to at least the conductive wire spring.

[0021] Examples of the embodiments of the present invention include heart rate monitor belts which are integrated within a garment. Additionally, examples include EMG monitor belts which are integrated within a garment. Examples of garments include shirts, compression shirts, undershirts, tops, bras, sports bras, underwear, undergarments, shorts or pants.

[0022] Furthermore, it is an object of certain embodiments to provide a pair of shorts or pants for EMG measurement. It is an aspect of certain of such embodiments that one or both of the legs of the shorts or pants includes at least one, and preferably two snap and electrode assemblies as described herein.

[0023] In a sensory for measuring a physiological signal, the outer layer can be a flexible and moisture-permeable substrate, which has an outer surface (first surface) and an inner surface (second surface) opposite to this. A signal transmission conductor can be arranged in a watertight manner on the inner surface of the substrate, so that interference signals cannot connect directly from the skin through the substrate. An electrode, with a signalling surface facing in the same direction as the outer surface of the flexible substrate can in turn be connected electrically to the transmission conductor.

[0024] In a method for manufacturing a sensory according to certain embodiments of the present invention, a flexible substrate is taken, which has an inner surface and an outer surface opposite to this. A signal transmission conductor, which is electrically connected to the electrode, is attached to the second surface of the substrate. The electrode is positioned relative to the substrate in such a way that its signalling surface faces in the same direction as the outer surface of the substrate.

[0025] The substrate can be a textile material or some other fibre manufacture. The electrode can be made of, for example, metal, or a conductive plastic, elastomer, individual fibres, or of a fibre material, such as a woven or knitted fabric. The transmission conductor can be of metal, a conductive plastic, a conductive rubber, a conductive elastomer, a conductive ink, a conductive polymer, a coating with a metal-particle content, a conductive fibre, a pack of fibres, or a fibre manufacture such as a conductive fabric.

[0026] A sensory may comprise a construction of at least three layers, in which there is a substrate layer that remains against the skin, a first insulating layer, and a conductor layer. Furthermore, another insulating layer can be arranged on the second surface of the conductor layer as a fourth layer. The task of the insulating layer is to prevent liquid, for example,

perspiration that accumulates in the substrate during exercise, from reaching the conductor layer and thus to prevent an electrical contact arising with the signal conductor and undesirable interference connecting with the electrode signal.

[0027] In the constructions provided herein, it is possible to combine flexibility of the structure and reliability of the signalling with the sensory's comfort in use. In particular, they permit the use of durable textiles substrates of a tested comfort, directly against the skin either entirely or nearly entirely in the whole area of the sensory. The transmission conductor of the signal is protected against stress, moisture, and electrical interference on the second side of the textile.

[0028] The constructions can also be manufactured entirely form the inner surface of the substrate, in which case the outer surface coming against the user remains untouched, except for the electrode openings. Thus, for example, the comfort and breathability of the textile substrate remain good, even at the conductors. The conductors also remain behind the textile layer, well protected from mechanical stress.

[0029] The constructions of a sensor product disclosed herein can also be implemented in such a way that the conductor structure remains in such a position in the finished sensor product that no elongating forces act on it when the product bends, or at least such forces are considerably smaller in the outer layers of the product. Thus such unstretchable and poorly stretchable conductor materials too can be used, which has been impossible in earlier solutions.

[0030] In particular, such constructions, in which the substrate, the first insulating layer, the conductor/electrode layer, and the second insulating are joined together as a pack, is advantageous in terms of manufacturing technique and use. If the insulating layers are attached to each other at the edges, a conductor structure will be achieved, which is insulated from moisture travelling both parallel to the surface and at right angles to the surface, and which is, in addition, thin and flexible. Such a structure can implemented in both a heart rate belt and in apparel.

BRIEF DESCRIPTION OF THE DRAWINGS

[0031] FIG. 1 shows a top perspective view of a snap integrated within a garment in accordance with an embodiment of the present invention.

[0032] FIG. 2 shows cutaway portion A-A of the integrated snap of FIG. 1 with the material of the garment removed.

[0033] FIG. 3 shows cutaway portion B-B of the integrated snap of FIG. 1 with the material of a garment as well as a male end of a telemetric device inserted in the socket region of the snap.

[0034] FIG. 4 shows a generic body of a telemetric device comprising male ends in accordance with an embodiment of the present invention.

[0035] FIG. 5 shows an example of a garment or heart rate monitor belt having two snaps in accordance with an embodiment of the present invention.

[0036] FIG. 6 shows a cutaway of a telemetric transceiver having a stud and male end in accordance with an embodiment of the present invention inserted within the socket region of a snap in accordance with the present invention.

[0037] FIG. 7A shows a stud for use in an electronic device in accordance with an embodiment of the present invention.

[0038] FIG. 7B shows a first example cutaway portion of the stud of FIG. 7A with a cavity.

[0039] FIG. 7C shows an alternative example cutaway portion of the stud of FIG. 7A without a cavity.

[0040] FIG. 8 shows an electrode snap assembly in accordance with an embodiment of the present invention.

[0041] FIGS. 9-11 show exploded views of constructions of sensors.

[0042] FIGS. 12a-12c show cross-sections of various sensor constructions more closely in the environment of the electrode.

[0043] FIG. 13 shows a cross-section of a sensor construction, which is protected from both sides.

[0044] FIG. 14 shows the use of the sensory in connection with a detachable electronics module.

[0045] FIG. 15 shows in greater detail contacting according to one embodiment, with a detachable electronics module.

DETAILED DESCRIPTION OF EXEMPLARY EMBODIMENTS

[0046] A snap 10 in accordance with an embodiment of the present invention is shown in FIG. 1. The snap is shown integrated within a material 18. As can be seen from the figure, the upper cap portion 12 of the snap 10 is essentially flush with the material 18, i.e. there is no significant protrusion. Such an integrated snap design is highly desirable when transitioning from stand alone heart rate monitor belts worn in addition to regular clothing to integrating the functionality of a heart rate monitor in to clothing itself.

[0047] As discussed herein, a heart rate monitor belt is the combination of electrodes and snaps in such an arrangement that they can be used to determine, measure and/or monitor the heart beat of an individual or animal wearing the belt. A heart rate monitor belt may be a standalone article in the form of, for example, a belt having a plurality of electrodes connected to a pair of snaps which can be worn, for example around the torso of a user. Additionally, a heart rate monitor belt can be integrated within a garment, for example a top or sports bra. As such, a garment having the components necessary for use in monitoring the heart rate of a user similar to a standalone heart rate monitor belt will likewise herein be referred to as a heart rate monitor belt.

[0048] A snap 10 in accordance with certain embodiments of the present invention should be integratable within an article. Additionally, the snap 10 should be capable of receiving, holding and enabling an electrical connection with a male end of a telemetric device. A more detailed description of telemetric devices follows below. The snap 10 generally comprises an upper cap portion 12, a base portion 14 and a conductive wire spring 16 as can be seen in FIG. 1.

[0049] The upper cap portion 12 includes a recess forming at least a portion of the sides 30 of a socket region 20 of the snap. The socket region 20 is for receiving a male end of a telemetric device. The upper cap portion 12 is more clearly seen in FIG. 2. The upper cap portion 12 has a top portion 13 and recess portion, as seen in FIG. 1, as well as a flange portion 26 as shown more clearly in FIG. 2. The top portion 13 can be generally flat and have a constant width around the recess in the center. In order to integrate in a flush manner with a material, the upper cap portion has a flange 26 which goes out from the top portion 13 at a lower height. In the present example, the top surface of the top portion 13 of the upper cap portion 12 is the top measure of height of the snap.

[0050] The amount of depression of the flange 26 compared to the top portion 13 can be equal to or approximately equal to the thickness of material 18 which the snap is to be integrated with. Additionally, the amount of depression can be a standard amount which is selected in order to work best with a

wide variety of material thicknesses. However, as can be seen in FIG. 1, it is advantageous for the material 18, being affixed on top of the flange portion 26 of the upper cap portion 12 to be essentially or substantially flush with the top portion 13 of the upper cap portion 12.

[0051] The recess in the upper cap portion 12 forms a socket region 20. The sides 30 of the recess generally form the sides of the socket region 20. While the sides 30 of the recess can have a plurality of geometries from generally vertical to something more complex, it is advantageous for the side wall geometry to be complementary to the male end of a telemetric transmitter to be detachably connected to the snap 10. Such geometries will be discussed in more detail below.

[0052] The socket region is generally formed by the sides 30 of the recess of the upper cap portion 12 and by a bottom, as seen in FIGS. 1 and 2. In the present examples, the sides 30 of the recess of the upper cap portion 12 extend to the bottom of the socket region 20 and contact a portion of a base portion 14 which forms the bottom of the socket region 20. However, it is possible for a portion of the base portion 14 to extend partially up the sides of the socket region 20 such that the sides of the socket region 20 are formed by a combination of a base portion 14 and the upper cap portion 12. Additionally, the recess of the upper cap portion 12 may comprise the sides and some or all of the bottom portion of the socket region.

[0053] In accordance with the present example, the upper cap portion 12 comprises an opening at the bottom of the recess. The upper cap portion 12 is coupled to a separate base portion 14 which forms the bottom of the socket region 20. The upper cap portion 12 and the base portion 14 are coupled in such a manner so that at least the interface at the bottom of the socket region 20 is water tight.

[0054] The sides 30 of the recess of the upper cap portion are additionally shown with two openings 32. Openings 32 are arranged at a height in between the top portion 13 and the bottom of the socket region 20 such that a portion of a conductive wire spring 16 can at least partially extend through the opening 32. The conductive wire spring 16 is for releasably holding the male end of a telemetric device within the socket region of the snap. Additionally, the conductive wire spring 16 make, or at least partially makes, the electrical connection between at least one electrode 24 in a garment or heart rate monitor belt and the male end of a telemetric device.

[0055] The conductive wire spring 16 is housed at least partially within a gap which is formed between the upper cap portion 12 and the base portion 14. More specifically, according to the present example, the gap is formed between the top portion 13 of the upper cap portion 12 and a portion of the base portion 14. The conductive wire spring 16, according to the present example, is mechanically coupled to the upper cap portion 12 by a lip 34 of the upper cap portion 12. The lip 34 may be within the gap formed between the top portion 13 of the upper cap portion 12 and the base portion 14 or the lip 34 may be located in another region of the snap 10. The conductive wire spring 16 may simply rest on the lip 34, there may be a friction fit between the conductive wire spring 16 and the lip 34 and/or other portion of the upper cap portion 12, there may be an additional mechanical means for holding the conductive wire spring 16, there may be a separate, or additional chemical means, such as an adhesive, for holding the conductive wire spring 16 or there may be some combination of the above. According to certain examples, the wire spring 16 is

not rigidly affixed to the upper cap portion 12 but is allowed a small degree of movement due to the mechanical fit of the lip 34 arrangement.

[0056] According to certain embodiments, as can be seen for example in FIG. 8, the lip 34 which holds the wire spring 16 can be formed from the flange 26 of the upper cap portion 12. One or more notches 35 can be formed, e.g. cut, out from the flange 26 and then bent back towards the socket region 20 to form the lip 34.

[0057] An example of conductive wire springs 16 can be a wire springs with a double 'S' shape. The wire spring 16 may have a diameter of between, for example, 0.6 to 0.8 mm. Examples of suitable materials are stainless steels, e.g. AISI 304 or 316. Additionally, the conductive wire spring 16 may be an integral component of either the upper cap portion 12 or the base portion 14.

[0058] An example of the conductive wire spring 16 is a double 'S' shape which takes the general shape of a horseshoe. In an example in accordance with FIG. 8, the wire spring 16 can be held by three lips 34 formed from three corresponding notches 35 which hold the wire spring 16 on the three sides of the horseshoe. As a result, two interior legs of the horseshoe, i.e. one leg from each of the 'S's' floats free and extends through the openings 32 in the side of the socket region.

[0059] The base portion 14 of the snap 10 is shown for example in FIGS. 2 and 3. Generally, the base portion 14 of the snap 10 complements the upper cap portion 12. According to the present example of the figures, the base portion 14 includes a recess at, or near the middle of the base portion 14 which corresponds to the recess of the upper cap portion 12. The recess of the base portion 14 is wider than that of the recess of the upper cap portion 12 such that at least a portion of the sides 30 of the upper cap portion 12 fit within the recess of the base portion 14. Having this overlap of the two portions aids in assuring a water tight coupling of the two portions at the socket region 20.

[0060] According to the present example, the bottom of the recess of the base portion 14 forms the bottom of the socket region 20. However, as described above, at least a portion of the bottom of the socket region 20 may be formed by the upper cap portion 12.

[0061] A guiding stud 22 may be provided at the bottom of the socket region. A guiding stud 22 may be added in order to increase the stability of the connection. In the present example the guiding stud 22 is provided on the bottom surface of the recess of the base portion 14. However, the snap of the present example may not have a guiding pin 22 but be otherwise the same as disclosed herein.

[0062] The guiding stud 22 acts to center and stabilize the male end of a telemetric device which has a recess compatible with the geometry and dimensions of the guiding stud. In FIG. 3 a male end of a stud 38 of a telemetric device 50 is shown detachably connected to the snap 10. FIG. 3 shows the cut-away section B-B from FIG. 1.

[0063] According to the present example, the guiding stud 22 is an integral portion of the base portion 14. The base portion 14 can be made of a non-conductive material such as a plastic or rubber based material. The guiding stud can be rigid or it may have some, preferably a slight, degree of flexibility. According to certain examples, the guiding stud 22 can be a separate piece which is attached or affixed to the bottom of the socket region. For example, the guiding stud 22 can be a stud or screw which is attached to the bottom of a

recess in a base portion during manufacturing. Similarly, if the bottom of the socket region is formed partially or entirely by the upper cap portion 12, the guiding stud may be an integral part, or an additional piece added to the upper cap portion 12. Still yet, the guiding stud may be an integral part, or an additional piece added to a base plate or mat which covers and/or forms the bottom of the socket region. Such a base plate or mat may be, for example a sticker or a piece with an adhesive which is added to the base portion 14 and/or the upper cap portion 12 at the bottom of the socket region 20.

[0064] According to certain examples of the present invention the guiding stud 22 can take the geometry of a standard cylinder. Additionally, it can be advantageous for the guiding stud 22 to have a conical geometry, for example as shown in FIG. 3. By having a conical geometry it allows for a stud 38 to have a slightly off alignment when entering the socket region and then aids in the centering and alignment of the stud 38 in to the detachably secured position as shown in FIG. 3.

[0065] According to the present examples, the thickest portion of the snap 10 is between the top portion 13 of the upper cap portion 12 and the bottom of the base portion 14 directly underneath the socket region 20. In order to produce a snap which has the least adverse effect on the garment which it is being integrated within, and therefore on the user wearing the garment, it is advantageous to keep this maximum thickness as small as possible. Currently, the standard snap thickness in the industry is around or above 4 mm. With the design of the present snap 10, the maximum thickness of the snap between the top 13 of the upper cap portion 12 and the bottom of the base portion 14 can be between about or even less than 1 to 3 mm or, for example between 1.5 to 2.5 mm. According to certain examples, utilizing the present design can reduce the overall size of the snap portion within a garment by 50-70% or more. This reduction in size is almost solely responsible for the success of integrating heart rate monitors in to garments.

[0066] As the snap 10 is, or is to be integrated within a material 18, the overall thickness of the snap 10 can gradually be reduced and/or tapered towards the outer edges, as is seen in the figures. The flange 26 of the upper cap portion 12 is depressed in order to reduce the overall thickness of the snap 10 as well as to allow for better integration with a material layer 18 of a garment. Similarly, as can be seen for example in FIG. 2, the outer portions of the base portion 14 are tapered such that the thickness of the base portion 14 and the snap 10 as a whole is reduced at the edges. FIG. 2 shows an example in which the base portion 14 extends past the edge of the flange 26 of the upper base portion 12. This extension can help in a more seamless integration of the snap 10 within a garment. However, as shown for example in FIG. 3, the base portion 14 may have a radius substantially equal to, or even less than, that of the upper cap portion 12.

[0067] As discussed with regards to the embodiments and examples herein, both the upper cap portion 12 and the base portion 14 are generally circular in shape. However, one of ordinary skill in the art will recognize that the geometry of one or both of the upper cap portion 12 and the base portion 14 can be freely selected without departing from the scope of the present invention.

[0068] While it is advantageous to minimize the maximum thickness of the snap 10, at the same time it is advantageous to maximize the depth of the socket region of the snap 10 within the overall maximum thickness of the snap 10. According to examples of the present invention the depth of the socket region of the snap between the top 13 of the upper

cap portion 12 and the bottom of the socket region is between 1 to 2.5 mm, preferably between 1.5 to 2.5 mm. Similarly, according to examples of the present invention, the depth of the socket region of the snap is between 80 to 98%, preferably between 85 to 97%, still more preferably between 90 to 95% of the maximum thickness of the snap 10.

[0069] Within the socket region 20 of the snap 10, according to the present examples and embodiments, it is advantageous for the height of the guiding stud to be at least 0.9 mm from the base of the socket region 20. However, according to certain embodiments and examples, it is advantageous for the height of the guiding stud to be between 0.5 mm to 2 mm, preferably between 0.8 mm to 1.5 mm. Similarly, according to examples of the present invention, the height of the guiding stud is between 20 to 80%, preferably between 30-50% of the depth of the socket region 20.

[0070] Additionally, the conductive wire spring 16 can be one of the bulkiest items within the snap. When the conductive wire spring 16 is at least partially housed within a gap created between the upper cap portion 12 and the base portion 14 around the side walls 30 of the socket region 20, it is advantageous to minimize the gap. According to certain embodiments and examples, it is advantageous for the maximum height of the gap to be between 0.5 to 2 mm, preferably between 0.5 to 1 mm.

[0071] Although the upper cap portion 12 and base portion 14 are described herein as being separate portions, they may be a single integral piece. However, for manufacturing purposes it is typically advantageous for the upper cap portion 12 and base portion 14 to be separate pieces. According to an example of the present invention, the upper cap portion 12 is a conductive material, e.g. a metal such as stainless steel, and the base portion 14 is a non-conductive material, e.g. a plastic or polymer based material. Similarly, the upper cap portion 12 can be made partially or wholly of a non-conductive material and/or the base portion 14 can be made partially or wholly of a conductive material. As such, it is significantly easier to manufacture the two pieces separately.

[0072] When separate pieces, the upper cap portion 12 and the base portion 14 can be coupled in a variety of non-exclusive ways. As discussed above, if the base portion 14 has a recess which corresponds to the recess of the upper cap portion 12, then the upper cap portion 12 and the base portion 14 can be coupled within the recess of the socket region by a mechanical and/or a chemical/adhesive means. Additionally, as shown for example in FIG. 2, the flange 26 of the upper cap portion 12 may comprise one or more openings through which the upper cap portion 12 can be coupled to the base portion 14 by a mechanical means. In the present example the mechanical means is a polymer rivet. However, any number of mechanical means can be used such as, for example, metal or chemical rivets, screws, studs, clips, etc. The mechanical means of connection may be present at, or towards the outer edges of the shorter of the upper cap portion 12 and/or the base portion 14. One of ordinary skill in the art will recognize countless means of attaching the two pieces which do not depart from the scope of the present invention.

[0073] A further example of a mechanical connection means 28 is that the base portion 14 comprises a plurality of integral extensions 28 which align with the openings in the upper cap portion 12, and optionally with openings in any electrode and/or other material between the upper cap portion 12 and the base portion 14. The extensions 28 will pass through the openings in the flange 26 and then heat, for

example in the form of an ultrasonic or laser application, essentially melts the top portion of the extension such that it forms the cap seen in FIG. 2.

[0074] In order for a garment to provide the necessary data to a telemetric transmitter, the garment should be provided with at least one, and typically at least two electrodes 24. Several methods for attaching and integrating an electrode 24 with a material 18 are known, for example as presented in U.S. application No. 11/808,391 filed Jun. 8, 2007 and published as US 2007/0285868 which has been incorporated by reference in its entirety. Additionally, the electrode 24 should make an electrical connection with a stud 38 of a telemetric transmitter through the snap 10.

[0075] As such, as can be seen for example in FIG. 2, the material 18 as shown in FIG. 1 has been removed and it is possible to see that the electrode 24, which is at least partially affixed and/or integrated within the material 18, is sandwiched between the flange 26 of the upper portion 12 and the base portion 14. For a snap which it to be integrated within a garment a gap is left between the flange 26 of the upper cap portion 12 and the outer portion of the base portion 14. According to the present examples, the gap should be equal to, or substantially equal to the thickness, or compressible thickness of an electrode which is to be connected with the snap 10 and or directly to a stud 38 detachably coupled to the snap 10. Within the gap, within another region of the snap or as a portion of either the upper cap portion 12 or the base portion 14, there can be a connector and/or connection region in which an electrode can be electrically connected to the snap or a portion thereof. For example, there can be a conductive region of the upper cap portion 12 which is in electrical contact with both an exposed portion of an electrode 24 as well as the conductive wire spring 16. Such a region can be mechanically or chemically/adhesively, connected to the electrode or the electrode may be frictionally fit against such a conductive or contact region.

[0076] According to an embodiment of the present invention a snap is manufactured and subsequently integrated within a garment. In such embodiments the snap may be manufactured in one or more pieces which may or may not correspond to the discrete portions described herein. According to another embodiment, the snap is manufactured in a plurality of pieces and is manufactured along with and integral with a garment or heart rate monitor belt.

[0077] As described herein, a garment can be any article which is wearable by a human or animal. Examples of garments which are particularly well suited for use with and incorporation with the present example are tops, shirts, sports bras, bras, undergarments, workout apparel, compression sports t-shirts, shorts, bands and belts. With regards to the remainder of the description, heart rate monitor belts and other specialty articles which one of ordinary skill in the art will recognize can implement the description of the present invention and be worn by a human or animal will be encapsulated in the term garment for simplicity. Furthermore, the garments discussed herein may be made of any suitable material including fabrics, cloths, and other such materials of natural or synthetic origin.

[0078] A benefit to the present snap is the flush integration of a snap in to a garment such that a garment having a snap in accordance with aspects of the present invention has minimal if any drawback compared to a garment not having a snap, when no measurement is to be taken by the garment.

[0079] Examples of heart rate monitor belts using elastomere or rubber electrodes can be found, for example, in WO 2005/032366. Furthermore, examples of textile electrodes can be found, for example, in WO 2002/071935. In addition to monitoring heart rate, the embodiments and examples herein may also be used for EMG monitoring or measurement.

[0080] Examples of such measurement devices can be found, for example, in WO 2004/002311 and WO 2005/032365. All of the above mentioned references are herein incorporated by reference in their entirety.

[0081] According to certain embodiments wherein the snap is an integral portion of a garment and/or the manufacture of the garment, an electrode 24 can be sandwiched between at least the flange 26 of the upper cap portion 12 and at least a portion of the base 14. Additionally, at least one material layer 18 can be disposed on a top portion of the electrode 24 and may, or may not, extend to cover a portion of the flange 26 or even the top portion 13 of the upper cap portion 12. Furthermore, one or more additional material layers 18 may be disposed on at least a portion of a bottom side of the electrode 24 and/or the bottom portion of the base portion 14 in order to more wholly integrate the snap in to the garment.

[0082] FIG. 5 shows an example of a garment 60 which has a top material layer 18 and two electrodes (not shown) which can be coupled to the back of material layer 18 or to another subsequent material layer. Each electrode is connected to a snap, 62A and 62B. Each of snaps 62A and 62B are in accordance with the snaps described herein. In a typical arrangement, the electrode attached to each snap would extend in a direction away from the other snap. As such, there will be an area between the two snaps which may or may not include an electrode or similar material.

[0083] A non-conductive, preferably water-proof material 64 can be added on top of at least a portion of one or both snaps. As shown in FIG. 6, the covering 64 covers a substantial portion of the top portion 13 of the upper cap portion 12, as well as the entire area of the flange 26 of the upper cap portion 12 of each snap. However, the covering 64 does not extend in to or over the recess or over or within the socket area. Additionally, a covering 64 may cover anything from none or a small portion of the top portion 13 of the upper cap portion 12 to virtually all of the top portion 13 of the upper cap portion 12. Furthermore, the covering extends and covers a portion of the area disposed between the two snaps 62A and 62B.

[0084] An example of a telemetric device 50 which is compatible with the garment 60 is shown in FIG. 4. The telemetric device 50 has a body portion 51, an aperture 53 for housing for example a battery, a surface surrounding the aperture 54 surrounded by an outer lip 56 and a cover 55, which can be for example a flexible sticker type cover with or without a graphic or textual display. Additionally, the telemetric device has two studs 38 having an exposed male end for being detachably coupled to the snaps 62A and 62B of garment 60.

[0085] As referenced above, it is advantageous for the side walls 30 of the socket region 20 to correspond with the geometry of the male end of the stud 38 of a telemetric device. As can be seen, for example in FIG. 3, the bottom portion of the recess of the upper cap portion 12 is slightly bent/chamfered inwards towards the center of the socket region. Similarly, the head of the stud 38 has corresponding chamfers 40. The chamfers 40 of the stud 38 head allow for easier guiding of the stud 38 in to the socket region of the snap 10.

[0086] FIG. 8 shows an example of a stud and electrode assembly in accordance with the present invention. An stud and electrode assembly is useful for the simple integration of the stud and electrode in to a heart rate monitor belt. The stud and electrode assembly comprises an electrode 24, and an integrated snap 10 having an upper cap portion 12, a conductive wire spring 16 in electrical connection with the electrode 24 and a base 14. The conductive wire spring 16 can be held within the snap by, for example, one or more lips 34 formed from corresponding notches 35 in the flange 26 of the upper cap portion 12.

[0087] The snap 10 can be arranged at any point and having any orientation with respect to the electrode 24. Additionally, the electrode 24 may take the shape of something other than a strip, as shown in the present example. However, it can be advantageous to integrate the snap 10 at or towards one end of a strip like electrode 24 as shown in FIG. 8.

[0088] According to the present example, the snap 10 is arranged near a terminal end of the electrode 24. The wire spring 16 is held within the snap 10 by three lips 34. The three lips 34, and consequently the three corresponding notches 35 are arranged in such a way that no notch opens towards the length of the strip electrode 24. This adds a degree of rigidity and support to the assembly.

[0089] Additionally, the openings 32 in the side of the socket region 20 of the snap 10 are arranged to be parallel with the length of the electrode 24. In other words, the openings 32 are arranged to be parallel with the sides of the electrode 24 as seen in FIG. 8. When two snap and electrode assemblies, for example two of the assemblies shown in FIG. 8, are integrated within a heart rate monitor belt, the snap 10 ends of the electrodes 24 will typically be arranged close to each other and the remaining tail portions of the electrodes will extend in opposite directions. When an electronic device is snapped in to the pair of snaps, the arrangement will provide stability in the direction of the arrangement, e.g. taking the orientation of FIG. 8, in the horizontal direction (along the length of the electrode). Thus, with the orientation of the openings 32 and the wire spring 16 as shown in the figure, the wire springs are capable of providing stability in the opposite direction, e.g. taking the orientation of FIG. 8, in the vertical direction (opposite the length of the electrode). Therefore, maximum stability can be obtained.

[0090] According to certain embodiments, when assembling the snap and electrode assembly an upper cap portion 12 can be affixed to an electrode 24 by means of, for example, a conductive tape 29. The conductive tape 29 can be seen in FIG. 8 where the notches have been formed in the flange 26. An opening corresponding to the socket region can be performed in the electrode. The conductive tape 29, e.g. a ring of conductive tape 29, can be placed on a first surface of the electrode and then the upper cap portion can be placed thereon. The conductive tape 29 can be a double sided conductive tape, for example having carbon fiber particles and copper plating.

[0091] The flange 26 of the upper cap portion 12 may have one or more openings preformed therein. Similarly, the electrode 24 may have one or more opening preformed therein which correspond to openings in the flange 26 or are otherwise for allowing one or more extensions from the base portion to pass there through. Additionally, one or more openings may be formed through the flange of the upper cap portion 12 and/or electrode 24. The base portion 14 is then affixed to the assembly by extensions 28 which pass through the openings

in the electrode and flange 26. The extensions 28 are then deformed, for example by means of an ultrasonic, laser or other heating means, in order to form caps and effectively sandwich the electrode between the upper cap portion 12 and the base portion 14.

[0092] The snap 10 of the snap and electrode assembly may be in accordance with any of the examples and embodiments of snaps described herein.

[0093] FIG. 4 shows a telemetric device 50 having two exposed male head portions of a studs 38. Typically, connection studs for telemetric devices have been molded within a casing of the telemetric device or otherwise integrated during manufacturing in a similar process. However, several problems arise with such manufacturing techniques when the devices are put under extreme conditions or exposed to liquid or vapor. Therefore, there is described herein a novel stud 38 for a telemetric device which is partially threaded and can be screwed in to an opening in a male connection end of a telemetric device. By coating at least a portion of the threads with an adhesive prior to screwing in to place the stud 38 can be securely fastened within the opening and insure a completely water-tight seal between the stud 38 and telemetric device which is far superior to any seal which can be made using a molding technique.

[0094] FIG. 7A shows an example of a stud in accordance with certain embodiments of the present invention. FIG. 7B shows a cutaway section of the stud of 7A. The stud 38 generally comprises or consists of three sections, a male head portion, a mid-portion and an end portion.

[0095] At least a portion of the male head portion is capable of fitting within a socket region of a snap. According to preferred embodiments of the present invention, the male head portion of the stud 38 is configured to fit within a socket region 20 of a snap 10 as described above. As such, at least a portion of the male head portion is disposed outside of the housing 51 of an electronic device. According to certain examples the entire head portion is located outside of the housing 51. Furthermore, according to certain examples, only the head portion is located outside of the housing 51.

[0096] In terms of the present disclosure, the male head portion has a terminal end which is the terminal end of the stud 38. The male head portion extends between said terminal end and a second end which separates the male head portion from a mid-portion. The length of the male head portion of the stud 80 is the length between the terminal end and the second end.

[0097] According to certain examples, the male head portion comprises a chamfered 40 terminal end which is chamfered from a maximum diameter 82 of the male head portion near the terminal end. The chamfer is added to guide a wire spring snap open, for example to guide the conductive wire springs 16 in the socket region 20 of the snap 10 open as the male head portion is inserted in to the snap. If the chamfers are too small then they are not efficiently capable of guiding the male head portion of the stud 38 in to a snap. The amount of chamfer is the difference between the maximum diameter 82 of the male head portion and the diameter 84 at the terminal end of the stud.

[0098] Additionally, beyond the maximum diameter 82 of the male head portion, towards the mid-portion, is a concave arced recess. The concave arced recess can be seen, for example, in FIGS. 7A, 7B, 7C and 3. The concave arched recess is for making a stable connection with a conductive wire spring 16 of a snap 10. According to the present

examples, the concave arched recess is slightly set back from the maximum diameter **82** of the male head portion. The region with the maximum diameter **82** can be flat or it may be at a point or apex of a curve. As shown, for example in FIG. 3, the male head portion may include a chamfer between the maximum diameter **82** of the male head portion and the beginning of the concave arched recess. Such a chamfer can be implemented to keep the male head portion of the stud in place until a critical pulling force is reached. The curvature of the concave arched recess can be selected to complement a desired or standard conductive wire spring **16** diameter.

[0099] Beyond the concave arched recess, towards the mid portion, is the second end of the male head portion. The second end may be an imaginary break between the male head portion and the mid-portion. However, according to certain examples, the second end may have a diameter **96** slightly larger than the end of the concave arched recess, and/or a shim, which can act as a stopper during the screwing process of inserting the stud **38** in to an opening of an electronic device. While in most examples the diameter **96** of the shim and/or second end of the male head portion is less than or equal to the maximum diameter **82** of the male head portion, the diameter **96** of the shim and/or second end of the male head portion may be larger than the maximum diameter **82** of the male head portion.

[0100] The end portion **72** of the stud is opposite the male head portion. The end portion has a terminal end which is the second terminal end of the stud, opposite the terminal end of the male head portion of the stud **38**. The end portion extends a distance from the second terminal end of the stud to the mid-portion of the stud which is the length **92** of the end portion **72** of the stud **38**. The division between the mid-portion of the stud and the end portion may be an imaginary break. However, the division between the mid-portion of the stud and the end portion may be a change in diameter and/or the break between the threaded portion and non-threaded portion at the opposite end of the stud from the male head portion.

[0101] According to certain examples, the end portion **72** of the stud is characterized in that it is non-threaded. Additionally, the terminal end of the end portion **72** can be chamfered inwards from the diameter **94** of the end portion **72**. The end portion **72** of the stud is for making an electromechanical connection between the stud **38** and a component of the electrical device.

[0102] In between the male head portion and the end portion **72** is the mid-portion **88**. According to certain examples, the mid-portion is characterized in that it is at least partially threaded. Additionally, according to certain examples the entire mid-portion **88** of the stud is threaded. The threads of the mid-portion **88** are a means of securing the stud **38** in an opening of an electronics device. An example of the threading for the mid-portion is Remform F 2.5 mm.

[0103] According to certain examples, the mid-portion **88** of the stud **38** has a constant diameter. Additionally, according to certain examples, the diameter of the mid-portion **88** is less than the diameter **96** at the second end of the male head portion. Furthermore, according to certain examples, the diameter of the mid-portion **88** is greater than the diameter **94** of the end portion **72** of the stud **38**.

[0104] According to certain embodiments of the present invention, the male head portion has a centered cavity **42** which is open at the terminal end of the male head portion. An example of such a cavity **42** is shown in the cutaway FIG. 7b.

The cavity **42** is for fitting over a guiding stud **22** of a snap **10** in accordance with the disclosure above. The presence of a guiding stud **22** in a snap **10** and a corresponding cavity **42** in a male head portion of a stud **38** allows for enhanced stability of the connection between the stud **38** and the snap **10** allowing for a significantly more compact snap design. While according to preferred embodiments the cavity **42** is centered on the terminal end of the male head portion, the cavity **42** may be off center according to other embodiments.

[0105] Additionally, the cavity can be utilized as a recess for a Torx or other tool during the screwing process during manufacturing when the stud **38** is inserted in to an opening of an electronics device. As such, the cavity can have a variety of dimensions and geometries including, for example, a cylindrical cavity, a conical cavity, a TORX PLUS, e.g. 10IP, 8IP or 6IP, geometry, cubic cavity and/or similar geometry or combination of thereof. The cavity may correspond directly to a guiding stud **22** of a snap **10** to which the stud **38** is to be inserted. Additionally, the cavity may have a different geometry which is merely compatible with the geometry of the guiding stud **22**. For example, the cavity may have a TORX PLUS IP6 geometry which has a diameter of 1.75 mm and the guiding stud may be cylindrical or conical having a maximum diameter of 1.75 mm or slightly less.

[0106] According to certain examples, the depth **86** of the cavity **42** should be at least 0.9 mm. According to other examples, the depth can be between 0.5 to 1.5 mm.

[0107] FIG. 7c shows an alternative example of a stud in accordance with the present invention in which the stud does not have a cavity **42**.

[0108] According to one example of a stud in accordance with the present invention, the length **80** of the male portion of the head is 2.1 mm, the maximum width **82** of the male portion of the head is 4.1 mm, the diameter **84** of the terminal end of the male head portion is 3 mm, the depth **86** of the cavity is 1.5 mm, the length of the mid-portion is 5 mm, the length **92** of the end portion is 2 mm, the diameter **96** of the second end of the male head portion is 3.6 mm, the threading of the mid-portion is Remform F 2.5 mm and the diameter **94** of the end portion is 1.5 mm.

[0109] More generally, the length **80** of the male portion of the head can be between 1 to 3 mm, the maximum width **82** of the male portion of the head can be between 3.9 to 4.3 mm, the diameter **84** of the terminal end of the male head portion can be between 2.8 to 3.6 mm, the depth **86** of the cavity can be between 0.8 to 1.5 mm, the length of the mid-portion can be between 3 to 5 mm, the length **92** of the end portion can be between 0 to 3 mm, the diameter **96** of the second end of the male head portion can be between 3 to 4 mm and the diameter **94** of the end portion can be between 1 to 2 mm.

[0110] Additionally, there is disclosed herein an electronic device **50** having a housing **51** and at least one male connection portion as shown for example in FIG. 6. The male connection portion(s) of the electronic device **50** are for detachably connecting the electronic device **50** to a female snap **10**. The male connection portion(s) of the electronic device **50** comprise a stud **38** as discussed above.

[0111] As shown, for example in FIG. 6, the entire male head portion of the stud **38** according to the present example is outside the housing **51** of the electronics device **50**. In accordance with preferred embodiments, the stud is made of an electrically conductive material. Additionally, one purpose of the stud is to facilitate an electrical connection between a portion of a snap **10** and an electronic component **76** of an

electronics device **50**. However, one of ordinary skill in the art will recognize embodiments of a stud **38** which is only partially made of a conductive material which can facilitate the electrical connection disclosed herein and as such would not depart from the scope of the present invention.

[0112] As described above, the stud **38** is threaded and is screwed in to an opening of the housing **51** of an electronic device during manufacturing. During or prior to the stud **38** being inserted and/or screwed in, at least a portion of the threads of the mid-portion of the screw are covered in and/or in contact with an adhesive. An example of an adhesive is Spedcaps Orange. The adhesive not only secures the stud **38** within the housing of the electronics device but it also helps form a water tight barrier between the environment and the electronic component **76**.

[0113] During manufacturing, an opening can be formed or manufactured in the housing **51** and/or internal cavity of an electronics device **50**. The opening can be threaded or unthreaded. In examples where the opening is unthreaded the material can be such that a threading is formed within the opening while the stud **38** is being screwed and/or inserted in to the opening. Additionally, while the present description describes an opening being pre-formed within a housing and/or cavity of an electronics device, one of ordinary skill will recognize embodiments in which a stud **38** can partially or wholly create its own opening in a housing and/or cavity of an electronics device, said embodiments which would not otherwise depart from the scope of the present invention.

[0114] At or towards the end of the opening in the electronics device is a component in which the end portion of the stud **38** is to be in electromechanical connection. The component may be an electronics component of the electronics device **50**. Additionally, for example in order to account for variations in the manufacturing process, at the end or towards the end of the opening may be a spring contact **70** which the stud is electromechanically connected to once screwed/inserted in to the opening. The spring contact **70** can then be electrically connected to an electronic component **76** such as a printed circuit board. The electric component **76** can be accessible by a cover **74** on top of the electronics device **50**.

[0115] Additionally, the housing **51** of the electronics device **50** may include a protrusion **68** at the male connection portion. The male head portion of the stud **38** may be partially or entirely outside of the housing and protrusion **68** of the electronics device **50**. The protrusion **68** can extend from the second end of the male head portion of the stud, e.g. the shim, at least partially along the mid-portion of the stud **38**. The protrusion **68** may extend, for example, between 0 to 2 mm from the base of the electronics device. Additionally, the protrusion **68** may have a diameter greater than the maximum diameter **82** of the male head portion of the stud.

[0116] According to an example of a system having an electronics device **50** and at least one snap **10** in accordance with the present description, the snap **10** can have a sealer **64**, for example as shown in FIG. 5. The sealer can be set back from the socket region **20** by a predetermined amount. Similarly, the protrusion **68** of the male connection portion can be designed to fit snugly within the gap left by the sealer **64**, as shown for example in FIG. 6. As such, the outer diameter of the protrusion **68** is substantially equal to, or slightly smaller than, the opening in the sealer **64**. Similarly, the length of the protrusion **68** can be substantially equal to or slightly more or less than the thickness of the sealer **64**.

[0117] Described herein, the electronic device **50** can be a telemetric transmitter and/or telemetric transceiver. Examples of telemetric transmitters and transceivers modules used with heart rate monitor belts to transmit information relating to the heart beat of a user to a remote receiver. One of ordinary skill in the art will recognize countless electronic devices and telemetric devices which can be used within the scope of the present invention. Such electronic devices may or may not comprise a display and may or may not be capable of wirelessly transmitting information. Additionally, they may be capable of sending a wide variety of data not limited to heart rate to a remote receiver.

[0118] Furthermore, disclosed herein is a system comprising one or more snaps **10** as described herein in combination with an electronic device having one or more studs **38** as described herein. Such a system can take the form of, for example, a heart rate monitor belt and a telemetric device for transmitting heart rate data from the heart rate monitor belt.

[0119] Additionally, a snap as described above can be integrated within and/or built in to a sensor as described below.

[0120] In FIG. 9, a substrate is marked with the reference number **100**. An opening **110** is made in it for an electrode contact. A moisture-insulating intermediate layer **120** is attached permanently on top of the substrate. An opening **130**, which can essentially coincide with the opening **110** can also be made in the intermediate layer. The openings **110** and **130** can, of course, also be made later in a single work stage. The electrode **150** is positioned relative to the opening **110** in the substrate and to the opening **130** in the intermediate layer, so that there is a contact connection to its signalling surface from the outer surface of the substrate **100** (from the skin). The signal transmission conductor **140** is attached on top of the intermediate layer **120**. Thus the signal transmission conductor **140** is attached to the substrate **100** with the aid of the electrically insulating and watertight layer **120**, which is located between the strip-like signal transmission conductor **140** and the substrate **100**. At one end, the conductor is connected electrically to the electrode **150**. At the other, its other end its is connected to the electronics module, or to the module's installation means **190**.

[0121] The substrate can be, for example, of a textile material manufactured from natural fibres and/or artificial fibres. The material can be woven or non-woven. It is preferably self-breathing, i.e. permeable by air and water vapour, and often also water. Thus it creates a comfortable feeling against the user's skin.

[0122] In FIG. 10a, the construction is further extended by adding a second intermediate layer **160** and surface layer **180**. The layer **160** ensures that the transmission conductor **140** will be watertight also from the second side. The layers **120** and **160** are attached directly to each other at the sides, so that the conductor layer **140** remains watertight between them.

[0123] According to one embodiment, the substrate continues unbroken from the sensory side facing against the skin to the side opposite to the sensory. Thus the substrate can surround the pack formed of the signal transmission conductor and the intermediate layer or intermediate layers from all sides, in which case both surfaces of the sensory will be formed of an unbroken material. Applied to the embodiment of FIG. 10a (and of FIG. 10b, to be examined in greater detail hereinafter), the layers **100** and **180** thus consist of the same unified material, which is bent at the sides of the sensory, in such a way that it encloses the other layer inside it. It is possible to use, for example, a sensory surface element

arranged in a tubular form, inside which the other layers of the sensory are placed. The other layers can be laminated as a ready pack before being placed inside the tubular surface layer. Alternatively, a planar substrate layer can be bent over the layers to the other side of the sensory after the application of the other layers and a joint can be formed on this side, for example, with the aid of adhesive. Opening for the electrodes and the electronics module connection are made in the tubular surface element. With the aid of the embodiments described, a tidy appearance is created in the edges of the sensory and the use of separate surface-layer elements is avoided.

[0124] According to one preferred embodiment, the second intermediate layer **160** is electrically insulating. It will then be possible to apply a second conductor structure on top of it. Such a second conductor structure can be used to create a second signal path, or electrical shielding layer. Thus with the aid of such a construction it is also possible to increase the sensing channels, or electromagnetic interference coming from the direction of the second surface can be effectively eliminated. The intermediate layers **120** and **160** are preferably of the same material. Always depending on the thickness and conductor structures of the intermediate layers, there can be several such layers, with no significant increase in the thickness of the sensory. More conductors can also be manufactured in a single layer and/or they can be overlapped in different layers.

[0125] According to one preferred embodiment, a conductor layer shielding from electromagnetic interference is arranged under and/or on top of the signal transfer path **140**, with the aid of the insulator-conductor layering technique described above. Two shielding layers can further be connected electrically to each other at the edges, in order to form a complete jacket for the signal conductor.

[0126] According to one embodiment, the intermediate layers **120** and/or **160** consist of electrically insulating laminates. The necessary conductor layers are applied to the substrate **100** and/or with each other on top of the laminates, before they are layered. Such a manufacturing manner is very easy to implement, cheap, and also retains its flexibility after the application of several layers. The laminate is preferably of a barrier type, generally a thin layer attached with the aid of heat, pressure, heat and pressure, or adhesive. For example, many seam laminates used in the apparel industry are suitable for this purpose. The laminate can at the same time also extend to the environment of the electrode **150**, as illustrated in FIGS. **9** and **10a**. Thus it reinforces the areas of the substrate **100** in the vicinity of the electrode and possibly even prevents the substrate from fraying around the hole **11** made in it.

[0127] According to one embodiment, the signal transfer path consists of a conductor substance, such as a conductive ink, a conductive polymer, or a coating with a metal-particle content, which can be spread in a fluid form. Such a conductor substance is spread on the support layer, the intermediate layer **120** and/or **160** being preferably used as such. In such a case, the surface of the intermediate layer is preferably such that it is possible to print directly onto it, i.e. the surface is print-ready. According to one aspect of the invention, a new use is indeed offered for a laminate attached to a textile substrate, as a base for a conductor material to be applied in a liquid form.

[0128] The signal transmission conductor can also comprise a conductor applied in a solid form, such as a rubber or elastomer conductor, a metal conductor, a conductive fibre, or a conductive textile. In this case too the conductor is prefer-

ably attached to the support structure or intermediate layer described above. Particularly TPU elastomer is well suited to this purpose.

[0129] According to one preferred embodiment, the signal-transmission conductor is non-metallic, in which case its conductivity can be in the range of, for example, 10^{-10} - $10^{-20}\%$ of the conductivity of a metal (copper). The permanent integration of non-metallic conductors with the layered construction presented is typically simpler than that of a metallic conductor, for example, using processes used in the textile industry.

[0130] The electrode **150** and the signal transmission conductor **140** can form a unified structure and/or consist of the same material, particularly is a conductive substance produced in a solid form is used.

[0131] An intermediate layer attached to the substrate, like the laminate described above, can be arranged to make the sensory non-stretchable or poorly stretchable. In that case too the flexibility of the structure will advantageously remain good. In particular, a non-stretchable intermediate layer will be appropriate, if a poorly stretchable signal conductor is used. By means of the pack construction described, the situation is thus achieved, in which the laminate layer or layers, possibly together with the textile layers, carrying the forces acting on the sensory.

[0132] FIG. **10b** shows a construction particularly suitable for heart rate belts. In it there is additionally a layer **170**, which is arranged on top of the electrodes **150** and the signal transmission conductor **140**, but under the electronics module, or its installation zone **190**. Thus, it formed a base for the installation zone. In the layer **170**, there are openings **171**, through which the overlapping of the layers can be implemented in such a way that the transmission conductor **140** is taken through the opening **171**, or a contact between the transmission conductor **140** and the installation zone **190** is made at the location of the opening **171**. At the same time, the layer **170** can also act as moisture protection for the signal transmission conductor **140**, and thus replace the intermediate layer **160** for this purpose. In the construction shown, mainly, for example, the textile-like surface layer **180** of the laminate layer **160** is used to attach the surface layer **180** to the sensory. At the same time, however, it protects and covers the openings **171** and thus protects the contacts from moisture.

[0133] In accordance with certain embodiments, at least one snap, as described above, can be integrated within the sensor in such a way that one electrode **150** is in electrical contact with the conductive spring of the snap. This electrical contact may be direct or indirect. For example, the electrical contact between the electrode and the conductive wire spring can be made via the transmission conductor **140**, such that the transmission conductor **140** is in direct contact with both an electrode **10** and a portion of the snap. The portion of the snap may be the conductive wire spring and/or the upper cap portion.

[0134] In an example such as provided in FIG. **10b**, two snaps may be provided at or near the installation zone **190**, each electrically connected to its own electrode **150**. The recess of the upper cap portion of each snap may be arranged through an opening **171** and/or one or more additional openings in other layers.

[0135] It can be seen from FIGS. **12a-12c** that the electrode **450** is arranged on the substrate **400** in such a way that there is a direct contact connection from the side of the first surface of the substrate **400** to the signalling surface **470**. The signal-

ling surface **470** is preferably at least on the same level as the first surface of the substrate **400**, as in FIGS. **12a** and **12c**. In some applications, it can also be deeper than the level of the surface of the substrate **400** in the manner shown in FIG. **12b**, particularly in the case of very thin substrates and/or when using electrodes with a very large surface area. In the figures, the laminate or other intermediate layer is marked with the reference number **420** and the signal transmission conductor, which is connected to the electrode and directly on top of the laminate **420**, with the reference number **440**.

[0136] An opening for the electrode is preferably made in the substrate. The electrode can be arranged at the location of the opening, or through the opening to, or through the surface of the substrate, using several different techniques. It can be brought to it as a ready fixed piece, in which case it is generally attached directly to the substrate, or to an intermediate layer arranged on top of it, in which there is preferably also an opening. If necessary, it is possible to use adhesives. The electrode can also be vulcanized, or sewn onto the substrate. Part of the substrate can also be treated to become conductive, for example, by impregnating it with a conductive substance, or coating the fibres of the substrate with a conductive substance. Suitable conductive substances are conductive polymers, inks, and adhesives. The electrode can also be insulated at the sides, in such a way that it is not in electrical contact with the substrate in these parts, or at all, in which case the signal will connect to the electrodes only through the signalling surface, even when the substrate is wet.

[0137] With reference to FIG. **13**, the sensory structure can, after the application of the electrode **550** and the signal transmission conductor **540**, be advantageously extended, in such a way that the signal transmission conductor **540** remains in an inner layer of the sensory structure. This preferably takes place in such a way that the stretch of the transmission conductor **540** when the finished structure is bent is substantially less than that of the outer layers **500**, **560** of the structure. Thus, such material layers **500**, **520**, **560**, **580**, or layer constructions, with relatively similar elongation and bending properties, are preferable on both sides of the conductor layer **540**. Their elongations generally differ from each other by 30% at the most and preferably by less than 15%. In that case, the signal transmission conductor will remain essentially on the zero axis of the bending elongation of the structure. Such an embodiment will protect the conductor from unnecessary elongation and contraction when using the sensory, and permit the sensory to be packed in a small space, for example a roll, without damage. The washing of the sensory, especially machine washing, will also stress the conductor layer mechanically, if it is wrongly located relative to the layers of the sensory.

[0138] The sensory according to the invention is suitable for use particularly in detecting the heart rate of the heart from the skin, for example, from the chest. Thus the sensory also typically comprises a second electrode like that described above and a second corresponding signal conductor to be placed on a different side of the chest. The sensory can also be used for measuring other electrical functions or properties of the body. Examples are measurement of the conductivity of the skin and of fat percentages, as well as the detection of muscle activation.

[0139] The sensory can be manufactured as part of a heart rate belt, or as a permanent part of, for example, underwear, sports apparel, a head band, or brassiere, in which case the textile material of these can act as such as the substrate of the

sensory. It can be made to be extremely thin and dense, thanks to its construction, and can be washed without moisture penetrating to the internal parts of the sensory.

[0140] For placing on the skin, one of the layers of the layered structure described above can extend outside of the actual sensory area. When integrated in apparel, this layer is typically the substrate layer, but in a heart rate belt application, for example, the elastic belt or band to be stretched around the chest can be manufactured to also continue from some other layer of the structure. Generally, in such a construction there are at least three layers arranged permanently on top of each other, one of which forms the signal conductor layer and one continues as a textile-like or elastic structure, in such a way that it can be arranged around some part of the body, in order to bring the signalling surface of the electrode substantially against the skin. As described above, at least one and preferably two of the layers form in addition a moisture protection for the transmission conductor.

[0141] One particular embodiment that can be referred to is a heart rate belt application, in which the sensory structure described is combined with an elastic belt or band, which is made 'too long' at the factory, and from which part can be cut off, so that the remaining length of the band will be suitable for the user's body. A connector piece can be attached to the end of the band, which can be fitted to a counter piece connected to the sensory. The band can also be sewn or glued to form a unified loop, in which case no plastic components will be required. The individual fitting of the band can be made by the reseller, for example, in a sports-goods store. In particular, an individually fitted heart rate band makes it possible to avoid the use of plastic length-adjustment pieces, as these are typically thick relative to the actual belt or band, and can be unpleasant during exercise.

[0142] In addition, other conductors in addition to the electrode-signal transmission conductors can also be laminated in the sensory structure. Examples of these are antennae and other electrical/optical conductors relating to other electrical/optical functions integrated in the apparel/device totality in question.

[0143] With the aid of the sensory structure described, it is also possible to manufacture medical sensors, for example, for electroencephalography (EEG), or electrocardiography (ECG). There can then be tens, or even hundreds of measuring channels. Such sensors are made economical, durable, washable, and comfortable for the patient. Patients' fear of tests can also be reduced by the fact that the signal paths of the various channels can be integrated reliably and unnoticeably in a fabric construction, thus giving the measuring unit a pleasant appearance.

[0144] With reference to FIG. **14**, the sensory can further comprise an installation zone **690** for the electronics module **610**, to which the signal transmission conductor **640** can be connected. In that case, the transmission conductor **640** is connected electrically to a contact area located in the installation zone **690**. The installation zone can comprise, for example, the ring structure **790** shown in FIG. **15**, in which metallic contact wires **720** are integrated. FIG. **15** also shows one possible way to implement the joint **730** between the signal transmission conductor **740** and the contact wires **720**. The joint **730** is preferably made using a joint moulding technique, which produces a durable joint with good electrical conductivity. The moulding technique can also be used as an aid in creating a durable joint **730** when using, for example, output conductive substances in the transmission conductor

140. The electronics module can be advantageously installed to be able to be detached later. Typically the contact components in either the installation zone or in the electronic module are flexible when installing the module, to create a good contact. Such a sensory arrangement will also withstand machine washing. The electronics module can also be connected to the transmission conductors in other ways, for example, with the aid of press-studs.

[0145] The electronics module typically contains means for transmitting, recording, or displaying a measured physiological signal. Typically it comprises a wireless signal transmitter, the terminal of which being, for example, a wristop computer, a computer, or some other heart-rate monitor.

[0146] It is to be understood that the embodiments of the invention disclosed are not limited to the particular structures, process steps, or materials disclosed herein, but are extended to equivalents thereof as would be recognized by those ordinarily skilled in the relevant arts. It should also be understood that terminology employed herein is used for the purpose of describing particular embodiments only and is not intended to be limiting.

[0147] Reference throughout this specification to “one embodiment” or “an embodiment” means that a particular feature, structure, or characteristic described in connection with the embodiment is included in at least one embodiment of the present invention. Thus, appearances of the phrases “in one embodiment” or “in an embodiment” in various places throughout this specification are not necessarily all referring to the same embodiment.

[0148] As used herein, a plurality of items, structural elements, compositional elements, and/or materials may be presented in a common list for convenience. However, these lists should be construed as though each member of the list is individually identified as a separate and unique member. Thus, no individual member of such list should be construed as a de facto equivalent of any other member of the same list solely based on their presentation in a common group without indications to the contrary. In addition, various embodiments and example of the present invention may be referred to herein along with alternatives for the various components thereof. It is understood that such embodiments, examples, and alternatives are not to be construed as de facto equivalents of one another, but are to be considered as separate and autonomous representations of the present invention.

[0149] Furthermore, the described features, structures, or characteristics may be combined in any suitable manner in one or more embodiments. In the following description, numerous specific details are provided, such as examples of lengths, widths, shapes, etc., to provide a thorough understanding of embodiments of the invention. One skilled in the relevant art will recognize, however, that the invention can be practiced without one or more of the specific details, or with other methods, components, materials, etc. In other instances, well-known structures, materials, or operations are not shown or described in detail to avoid obscuring aspects of the invention.

[0150] While the forgoing examples are illustrative of the principles of the present invention in one or more particular applications, it will be apparent to those of ordinary skill in the art that numerous modifications in form, usage and details of implementation can be made without the exercise of inventive faculty, and without departing from the principles and

concepts of the invention. Accordingly, it is not intended that the invention be limited, except as by the claims set forth below.

1. A snap and electrode assembly, integrateable with, integrated with and/or built in to a heart rate monitor belt, said snap being for receiving, holding and enabling an electrical connection with a male end of an electronic device, said assembly comprising;

an upper cap portion having a recess forming at least a portion of the sides of a socket region of a snap for receiving a male end of an electronic device, wherein the upper cap portion further comprises an outer flange region which at least partially surrounds the recess

a base portion coupled to the upper cap portion and forming at least a portion of a channel between the base portion and the upper cap portion around the periphery of the socket region,

a conductive wire spring housed at least partially within the gap for releasably holding the male end of the electronic device within a socket region of the snap, and

the snap comprises at least one means of mechanically coupling the wire spring to the snap, and

an electrode or transmission conductor connection to an electrode which is held between at least the outer flange region of the upper cap portion and the base portion and is electrically connected to at least the conductive wire spring.

2. A snap and electrode assembly in accordance with claim 1, wherein the electrode has a hole corresponding to the recess of the upper cap portion and the upper cap portion of the snap is affixed to one surface of the electrode and the base portion is coupled to the upper cap portion and electrode from the opposite surface of the electrode.

3. A snap and electrode assembly in accordance with claim 1, wherein the portion of the upper cap portion forming sides of the recess has at least one opening, and wherein the conductive wire spring partially extends through the at least one opening in to the socket region formed by the recess.

4. A snap and electrode assembly in accordance with claim 1, wherein the electrode is in the form of an elongated strip and the snap is arranged towards one terminal end of the electrode.

5. A snap and electrode assembly in accordance with claim 4, wherein at least one opening in the sides of the recess of the upper cap portion of the snap is arranged in a direction substantially parallel to the elongated length of the electrode strip.

6. A snap and electrode assembly in accordance with claim 2, further comprising a double sided conductive tape between at least a portion of the flange of the upper cap portion and the surface of the electrode on which the upper cap portion is affixed.

7. A heart rate monitor belt comprising;

at least one material layer,

two electrodes coupled to the at least one material layer, said electrodes arranged to detect the heart rate of a human or animal wearing the heart rate monitor belt, and a separate snap coupled to each of said electrodes or to a transmission conductor coupled to the electrode, each of said snaps configured to receive, hold and enable an electrical connection to a male end of an electronic device,

wherein each snap is integrated within or built within the heart rate monitor belt and each snap further comprises;

an upper cap portion having a recess forming at least a portion of the sides of a socket region of a snap for receiving a male end of a telemetric device,
 a base portion coupled to the upper cap portion and forming at least a portion of a channel between the base portion and the upper cap portion around the periphery of the socket region,
 a conductive wire spring housed at least partially within the gap for releasably holding the male end of a telemetric device within a socket region of the snap,
 the upper cap portion further comprises an outer flange region which at least partially surrounds the recess,
 the snap comprises at least one means of mechanically coupling the wire spring to the snap, and
 the electrode or transmission conductor is held between at least the outer flange region of the upper cap portion and the base portion and is electrically connected to at least the conductive wire spring.

8. A heart rate monitor belt in accordance with claim 7, wherein at least one material layer covers at least a portion of the upper cap portion of each snap and another material layer covers at least a portion of the base portion of each snap.

9. A heart rate monitor belt in accordance with claim 7, wherein;

each electrode is an elongated strip,
 each snap is located towards a terminal end of each electrode,

the ends of each electrode having a snap are arranged near to each other and each electrode extends away from the other,

the portion of the upper cap portion of each snap forming sides of the recess has at least one opening, and wherein the conductive wire spring partially extends through the at least one opening in to the socket region formed by the recess, and

wherein the at least one opening in the sides of the recess of the upper cap portion of each snap is arranged in a direction substantially parallel to the elongated length of the electrode strip to which it is affixed.

10. A heart rate monitor belt in accordance with claim 7, wherein;

each electrode is electrically coupled to an elongated transmission conductor,

each snap is located towards an end of the transmission conductor opposite the electrode,

the ends of each transmission conductor have a snap arranged near to each other and each electrode extends away from the other,

the portion of the upper cap portion of each snap forming sides of the recess has at least one opening, and wherein the conductive wire spring partially extends through the at least one opening in to the socket region formed by the recess, and

wherein the at least one opening in the sides of the recess of the upper cap portion of each snap is arranged in a direction substantially parallel to the elongated length of the transmission conductor to which it is affixed.

11. A heart rate monitor belt in accordance with claim 8, wherein the heart rate monitor belt is integrated within a garment.

12. A heart rate monitor belt in accordance with claim 8, wherein the garment is a shirt, compression shirt, undershirt, top, bra, sports bra, underwear, undergarment, shorts or pants.

13. A pair of shorts or pants for EMG measurement, wherein at least one leg comprises;

at least one material layer,

two electrodes coupled to the at least one material layer, said electrodes arranged to detect the heart rate of a human or animal wearing the heart rate monitor belt, and a separate snap coupled to each of said electrodes or to a transmission conductor coupled to the electrode, each of said snaps configured to receive, hold and enable an electrical connection to a male end of an electronic device,

wherein each snap is integrated within or built within the heart rate monitor belt and each snap further comprises; an upper cap portion having a recess forming at least a portion of the sides of a socket region of a snap for receiving a male end of a telemetric device,

a base portion coupled to the upper cap portion and forming at least a portion of a channel between the base portion and the upper cap portion around the periphery of the socket region,

a conductive wire spring housed at least partially within the gap for releasably holding the male end of a telemetric device within a socket region of the snap,

the upper cap portion further comprises an outer flange region which at least partially surrounds the recess,

the snap comprises at least one means of mechanically coupling the wire spring to the snap, and

the electrode or transmission conductor is held between at least the outer flange region of the upper cap portion and the base portion and is electrically connected to at least the conductive wire spring.

14. A pair of shorts or pants in accordance with claim 13, wherein each leg comprises;

at least one material layer,

two electrodes coupled to the at least one material layer, said electrodes arranged to detect the heart rate of a human or animal wearing the heart rate monitor belt, and a separate snap coupled to each of said electrodes or to a transmission conductor coupled to the electrode, each of said snaps configured to receive, hold and enable an electrical connection to a male end of an electronic device,

wherein each snap is integrated within or built within the heart rate monitor belt and each snap further comprises;

an upper cap portion having a recess forming at least a portion of the sides of a socket region of a snap for receiving a male end of a telemetric device,

a base portion coupled to the upper cap portion and forming at least a portion of a channel between the base portion and the upper cap portion around the periphery of the socket region,

a conductive wire spring housed at least partially within the gap for releasably holding the male end of a telemetric device within a socket region of the snap,

the upper cap portion further comprises an outer flange region which at least partially surrounds the recess,

the snap comprises at least one means of mechanically coupling the wire spring to the snap, and

the electrode or transmission conductor is held between at least the outer flange region of the upper cap portion and the base portion and is electrically connected to at least the conductive wire spring.

* * * * *

专利名称(译)	用于心率监测带的卡扣和电极组件		
公开(公告)号	US20130131484A1	公开(公告)日	2013-05-23
申请号	US13/731152	申请日	2012-12-31
[标]申请(专利权)人(译)	松拓有限公司		
当前申请(专利权)人(译)	SUUNTO OY		
[标]发明人	PERNU KIMMO SELBY TAPIO LINDBERG PHILLIP MANNI JUKKA LILJEMARK JORMA SAVOLAINEN TAPIO PUTKINEN HANNU AKKILA JARI RAHKONEN SATU LINDMAN ERIK		
发明人	PERNU, KIMMO SELBY, TAPIO LINDBERG, PHILLIP MANNI, JUKKA LILJEMARK, JORMA SAVOLAINEN, TAPIO PUTKINEN, HANNU AKKILA, JARI RAHKONEN, SATU LINDMAN, ERIK		
IPC分类号	A61B5/0245 A61B5/00 A61B5/0408 A61B5/0416		
CPC分类号	A61B5/0245 A61B5/0416 A61B5/6831 A61N1/0484 A61B5/6804 A61N1/22 A61B5/04085		
优先权	2006005391 2006-06-08 FI		
其他公开文献	US8886281		
外部链接	Espacenet USPTO		

摘要(译)

本发明一般涉及一种薄的，低厚度的按扣，其集成在心率监测带或按扣和电极内或装配在其内。按扣可以直接集成或构建在心率监测带上。此外，心率监测带可以集成在纺织品或服装内，例如压缩衬衫，运动胸罩或骑行短裤。按扣可以齐平地整合到腰带或衣服中，使得按扣不会带走心率监测带或衣服的一般耐磨性。

