



(19) **United States**

(12) **Patent Application Publication**  
**McKenna et al.**

(10) **Pub. No.: US 2011/0213216 A1**  
(43) **Pub. Date: Sep. 1, 2011**

(54) **ADAPTIVE WIRELESS BODY NETWORKS**

(52) **U.S. Cl. .... 600/301**

(75) **Inventors: Edward M. McKenna, Boulder, CO (US); Daniel Lisogurski, Boulder, CO (US)**

(57) **ABSTRACT**

(73) **Assignee: Nellcor Puritan Bennett LLC, Boulder, CO (US)**

Systems, methods, and devices for obtaining physiological measurements of a patient using an adaptive body network are provided. In one example, a wireless medical sensor may include physiological sensor circuitry, wireless transceiver circuitry, and control circuitry. The physiological sensor circuitry may be capable of obtaining a physiological measurement of a patient. The wireless transceiver circuitry may be capable of joining a wireless web that includes at least one other wireless medical sensor, through which the wireless transceiver circuitry may communicate the physiological measurement to an external device. The control circuitry may be capable of determining a data update rate at which to operate the physiological sensor or the wireless transceiver circuitry, or a combination thereof, based at least in part on a status of the patient.

(21) **Appl. No.: 12/714,532**

(22) **Filed: Feb. 28, 2010**

**Publication Classification**

(51) **Int. Cl. A61B 5/00 (2006.01)**

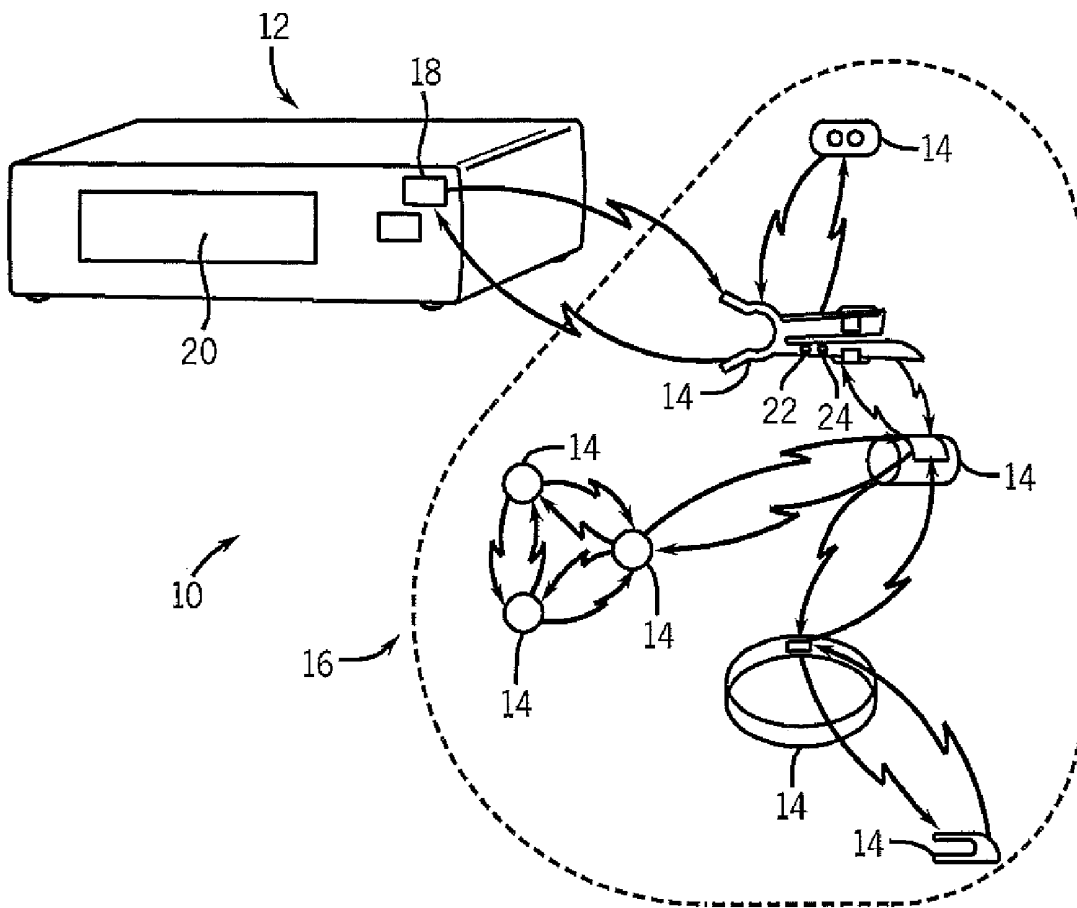

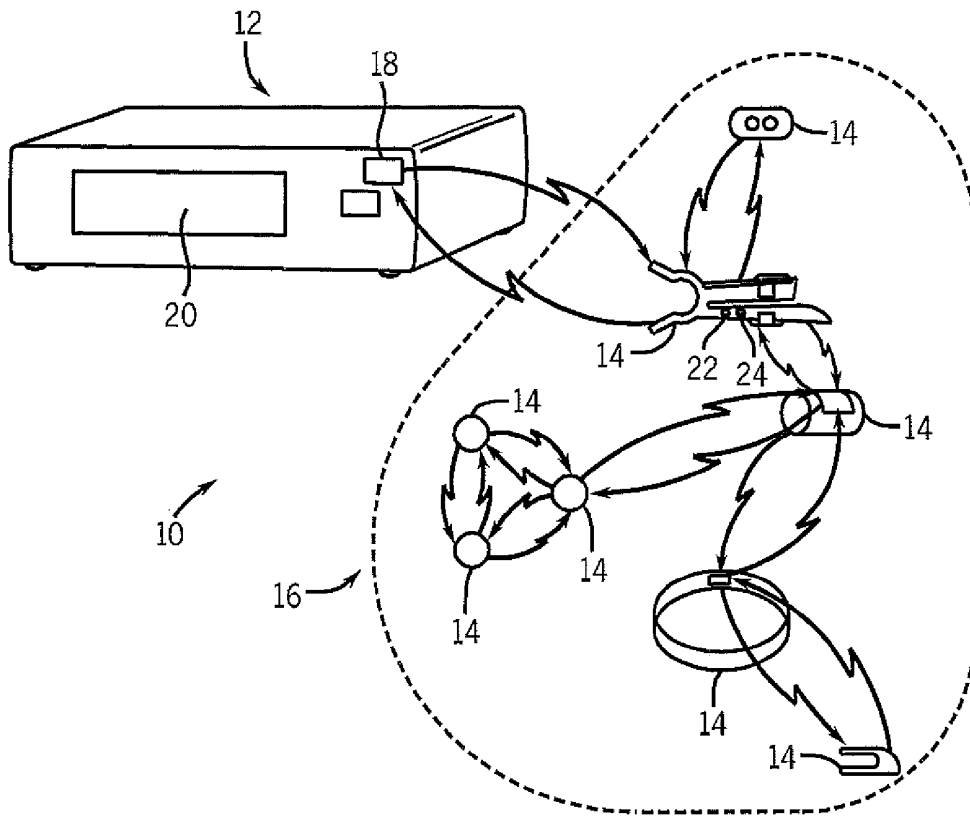

FIG. 1

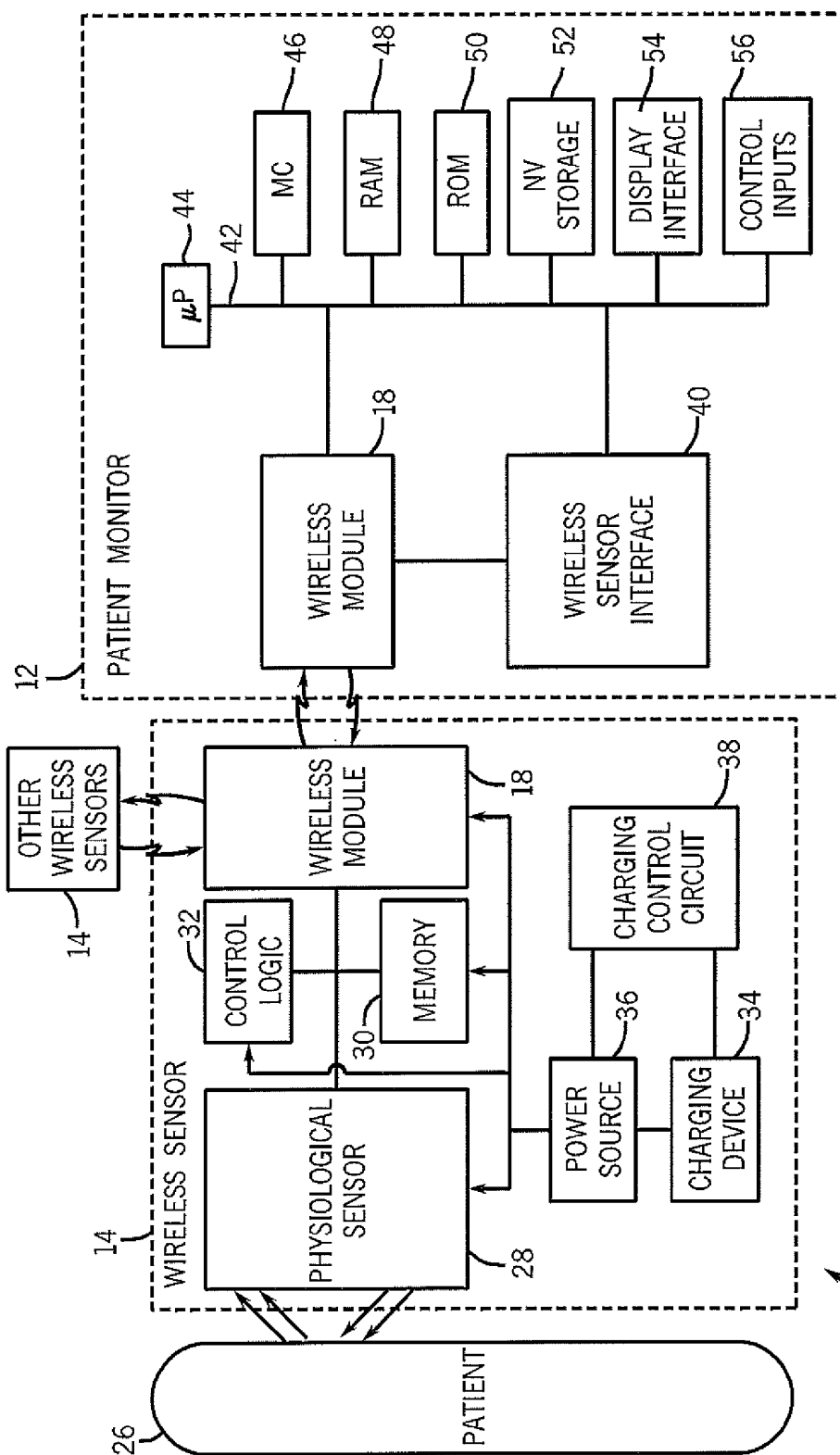
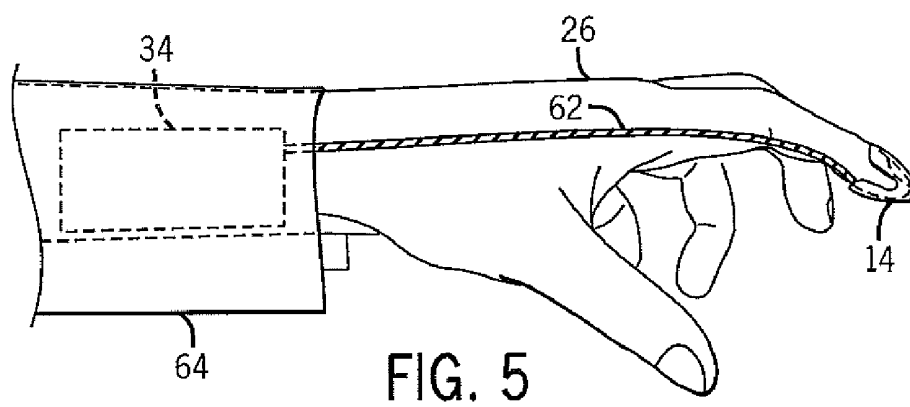
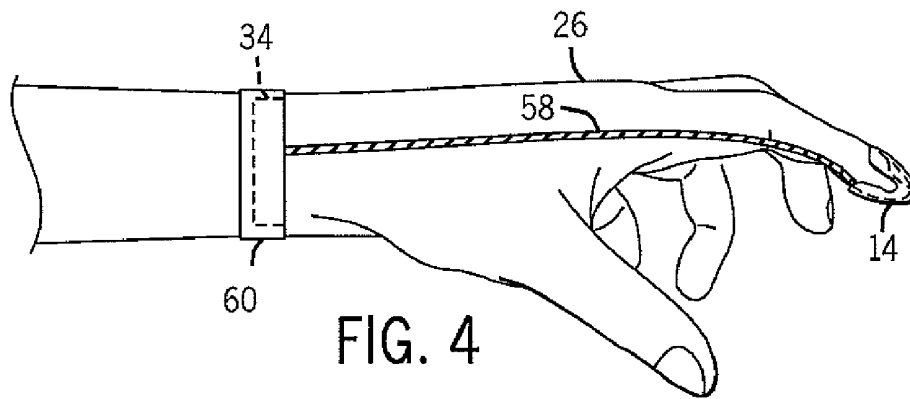
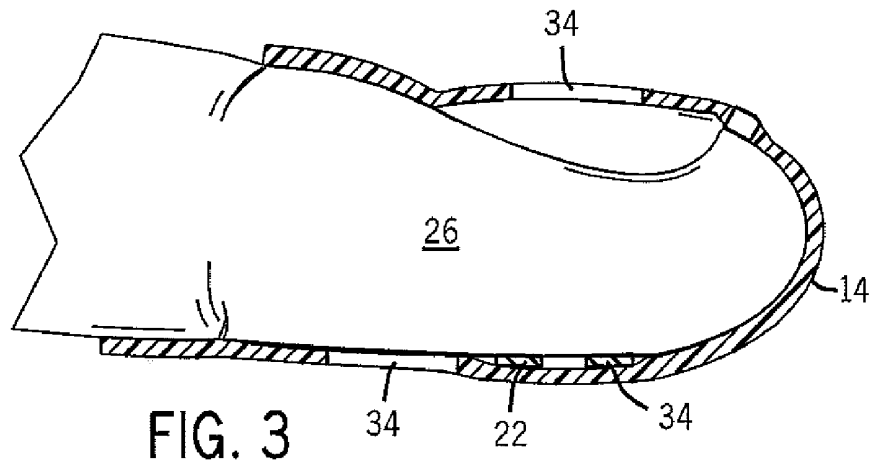

FIG. 2



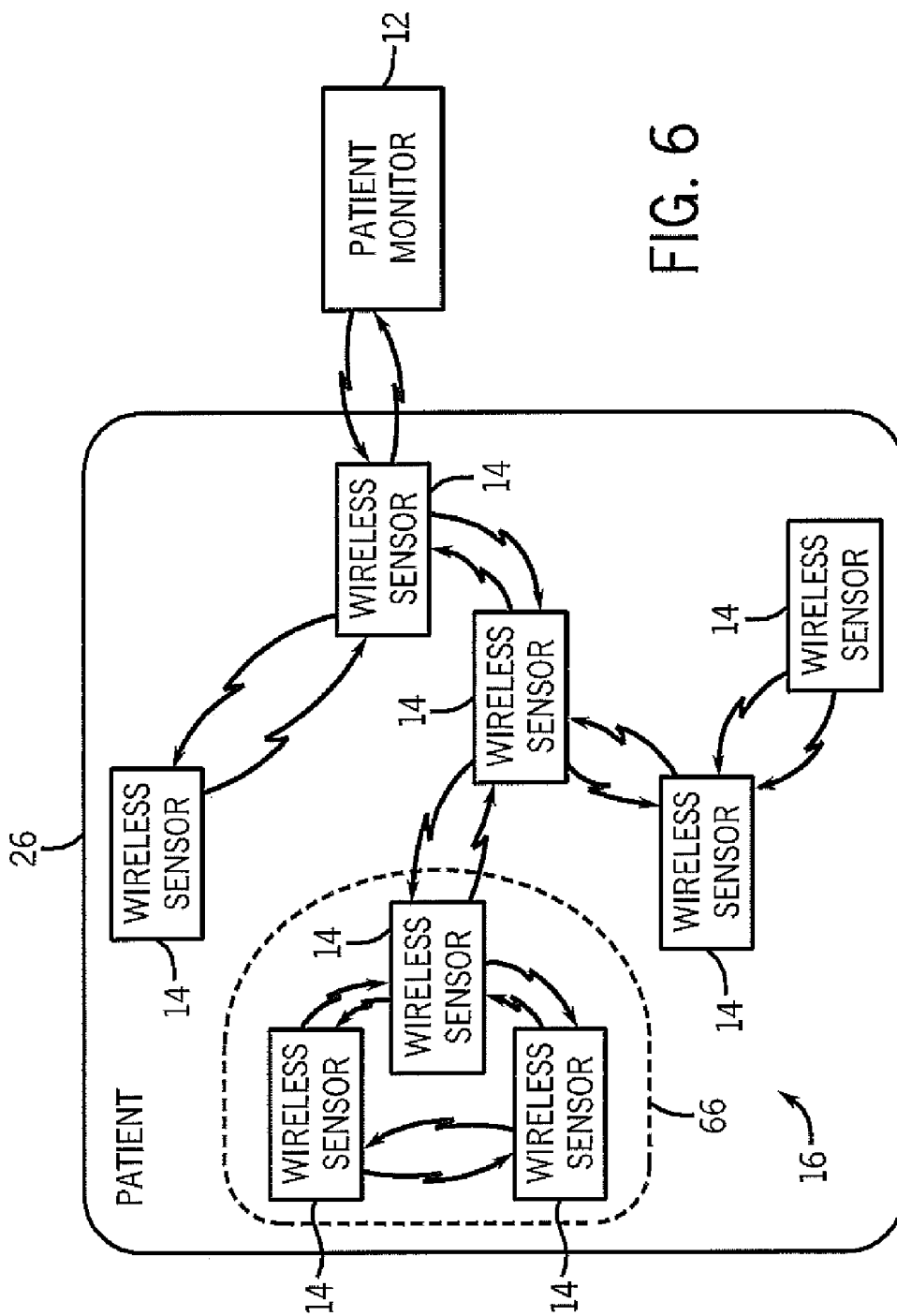
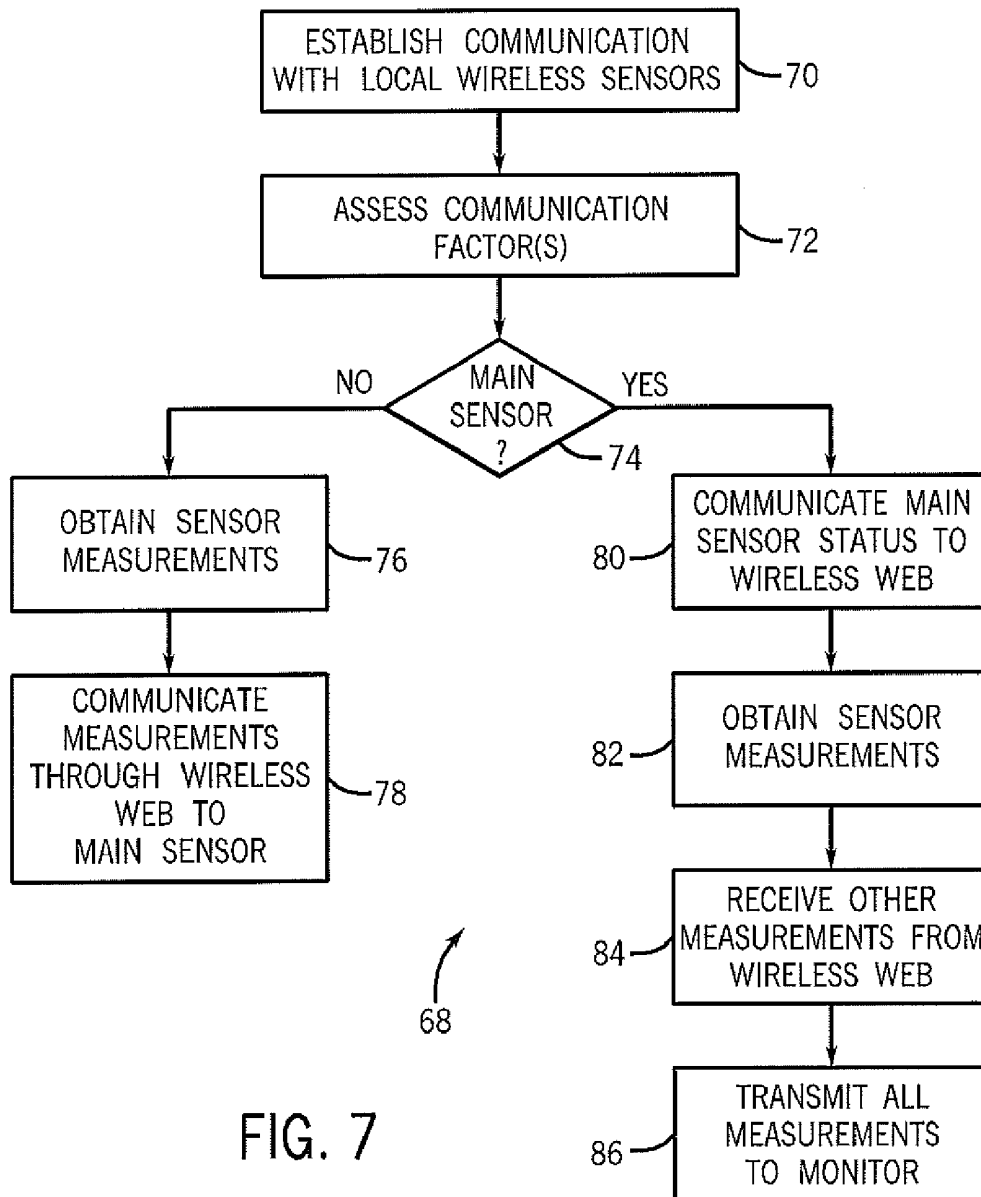
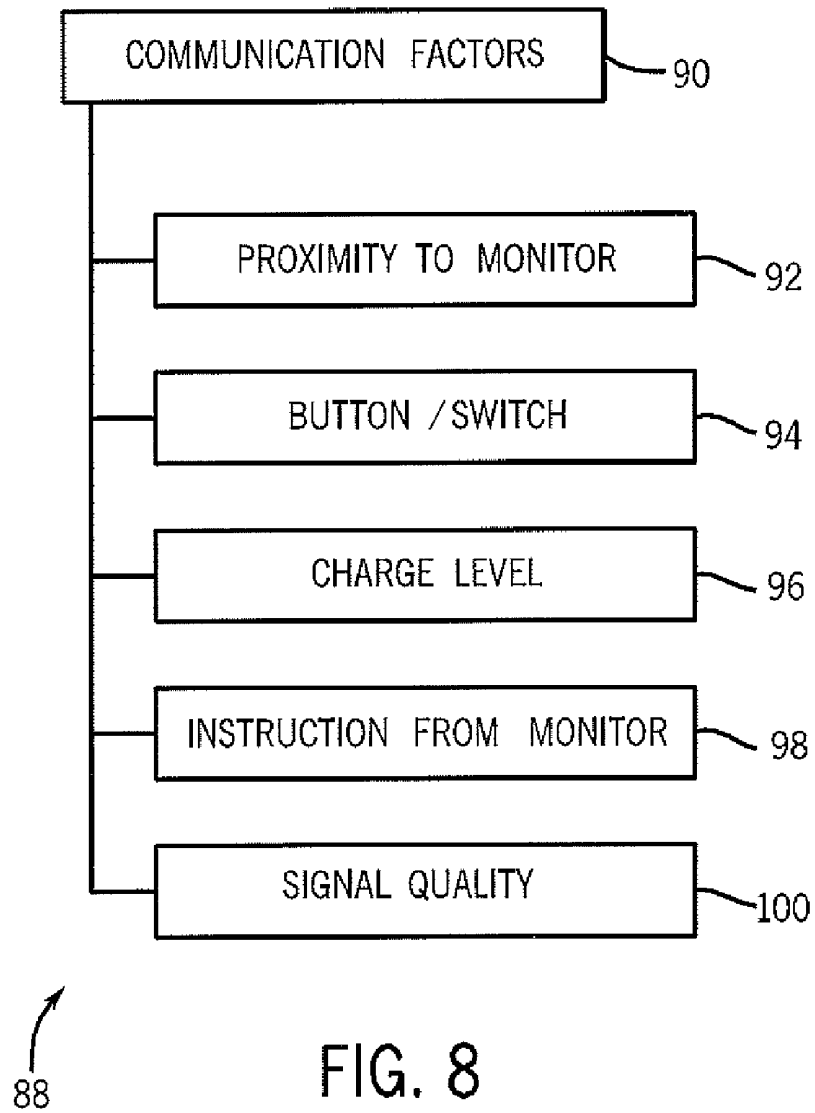
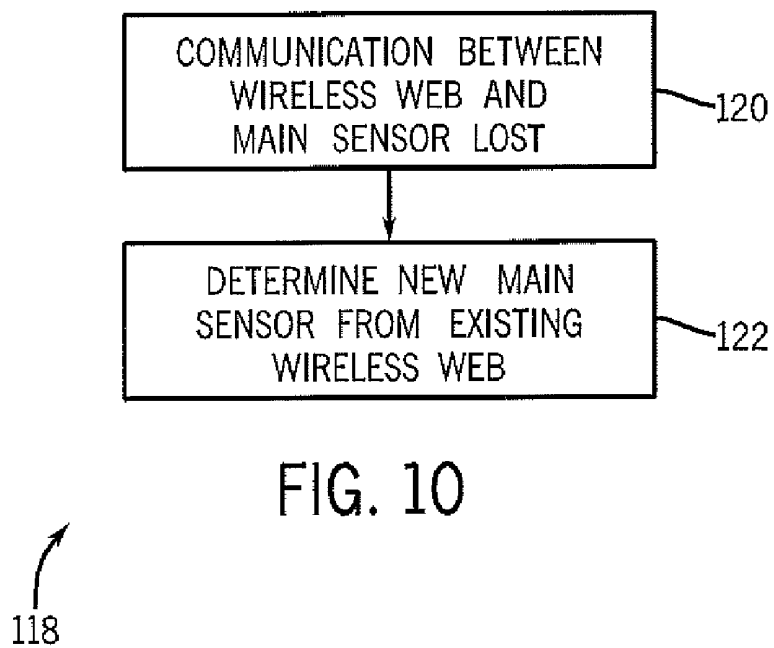
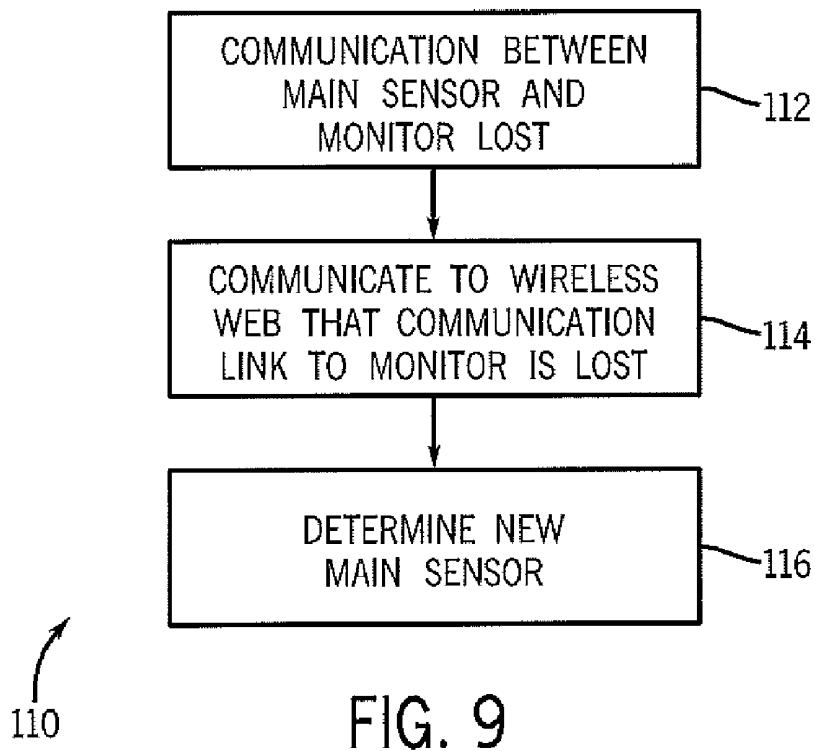

FIG. 6







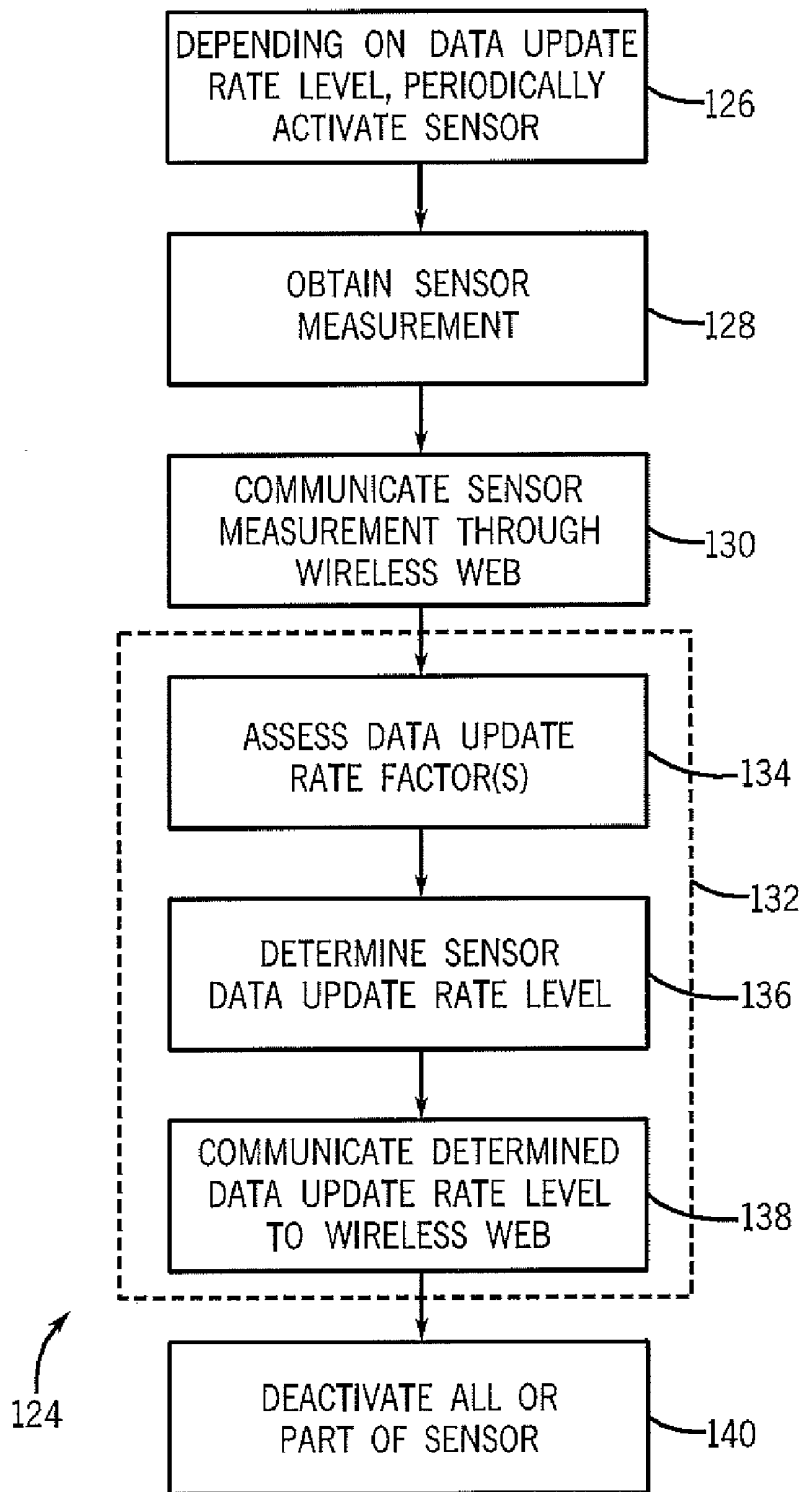

FIG. 11

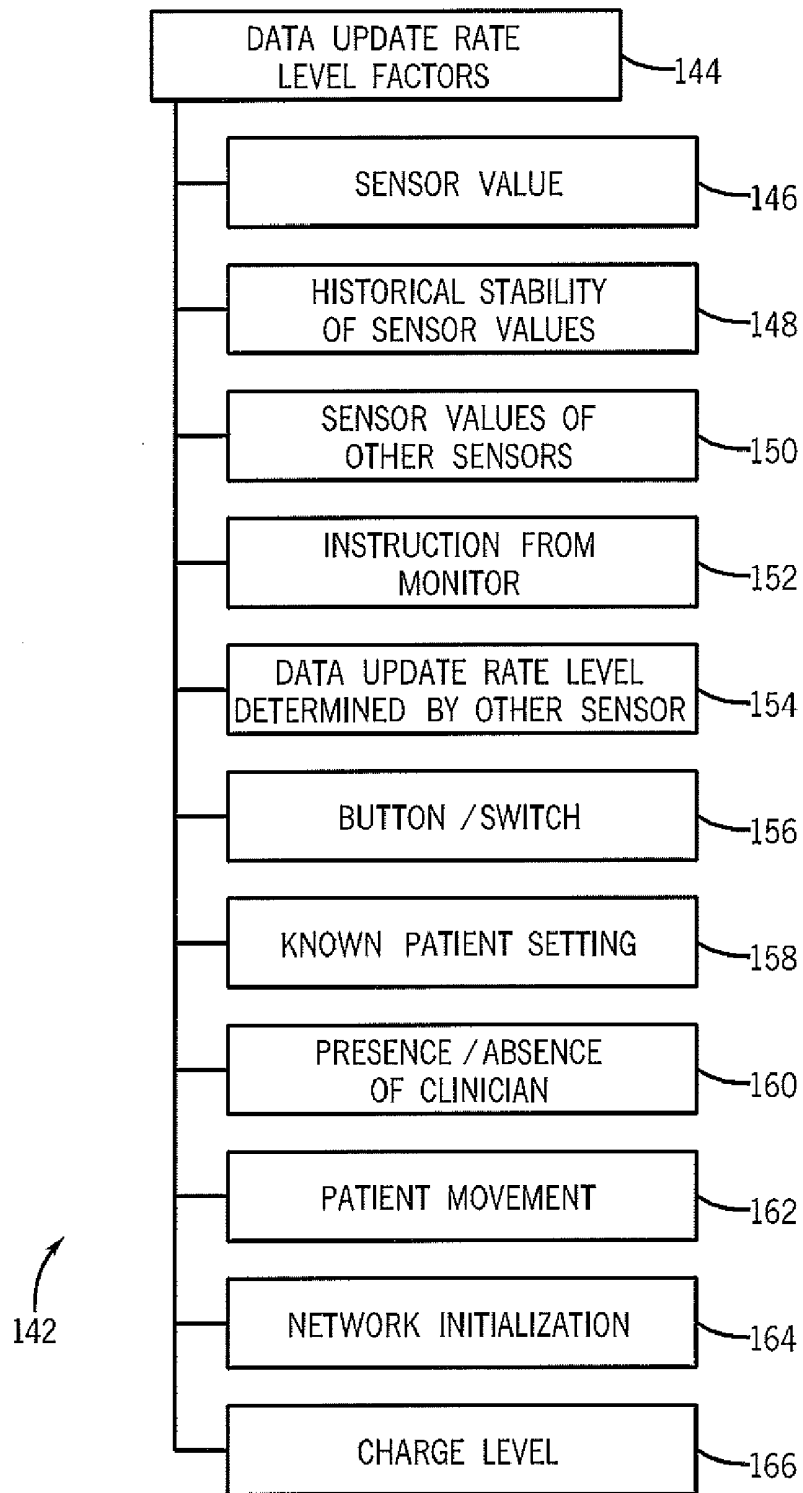

FIG. 12

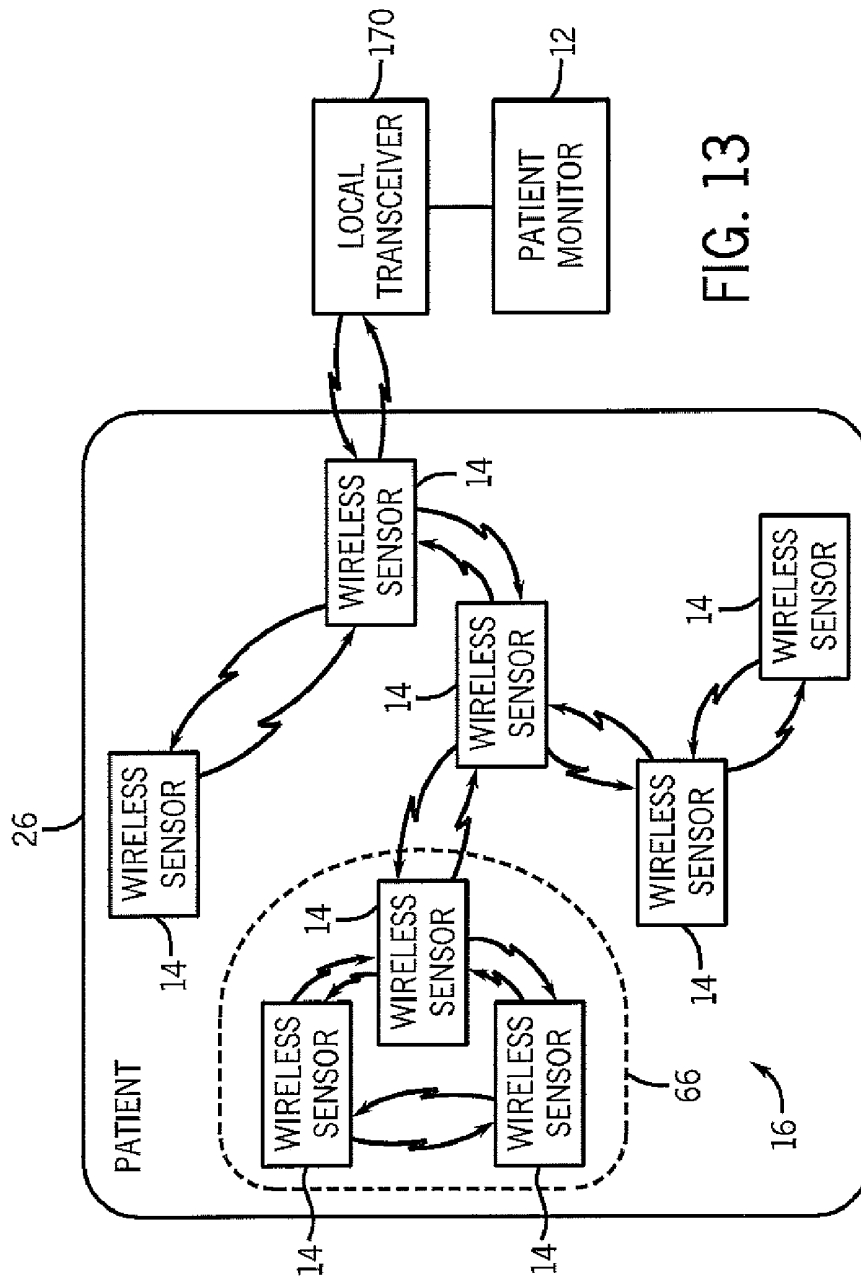

FIG. 13

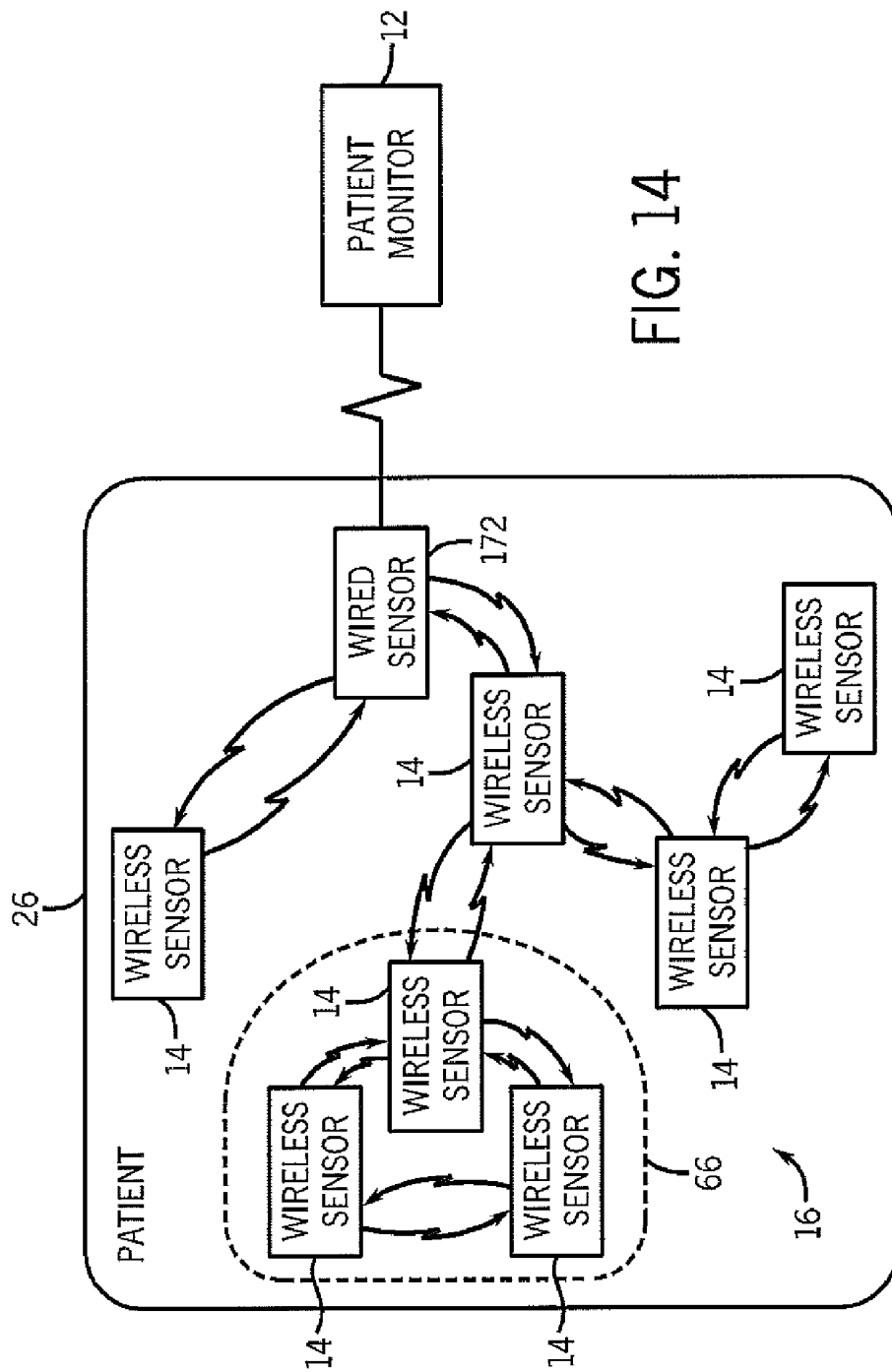

FIG. 14

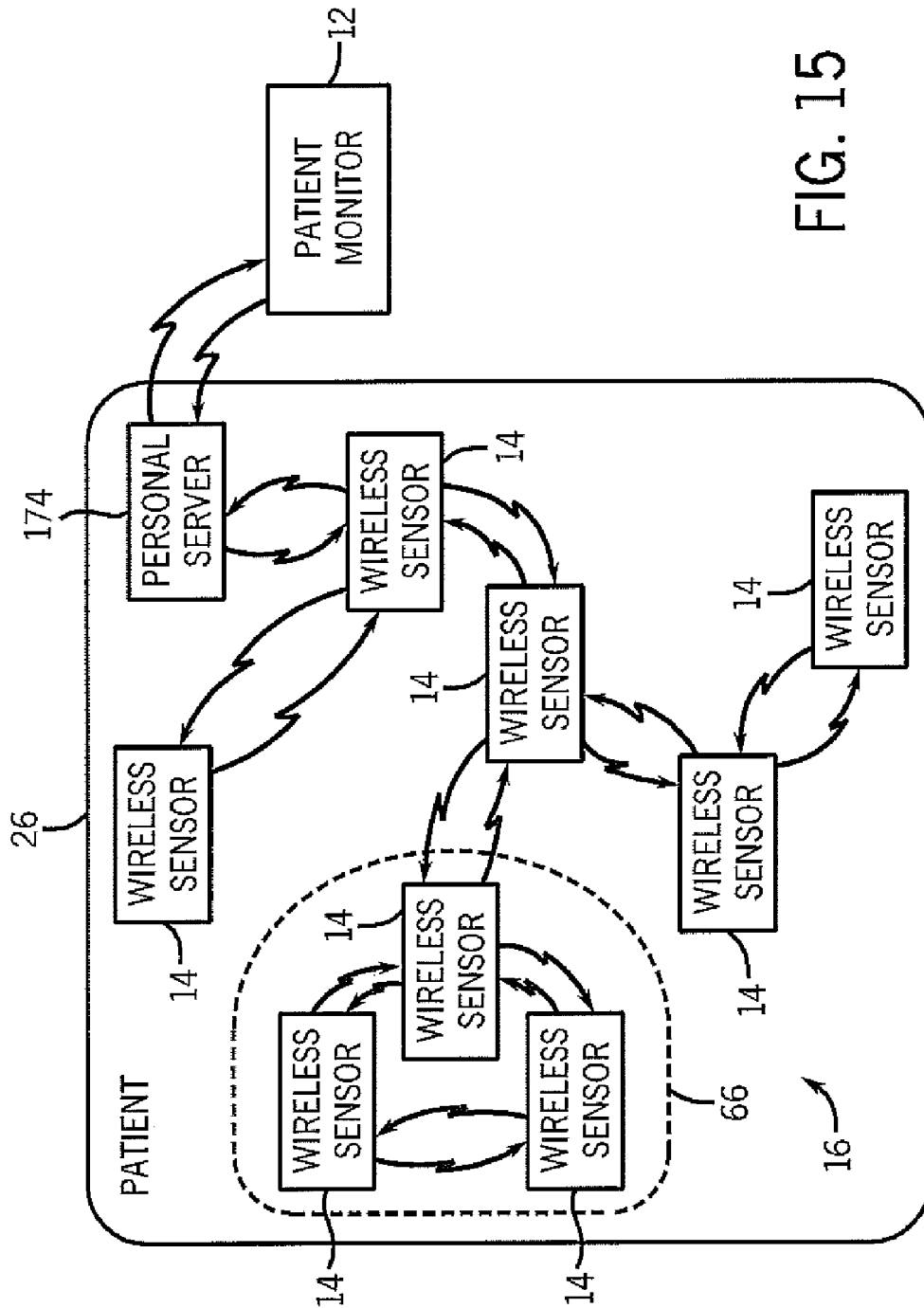

FIG. 15

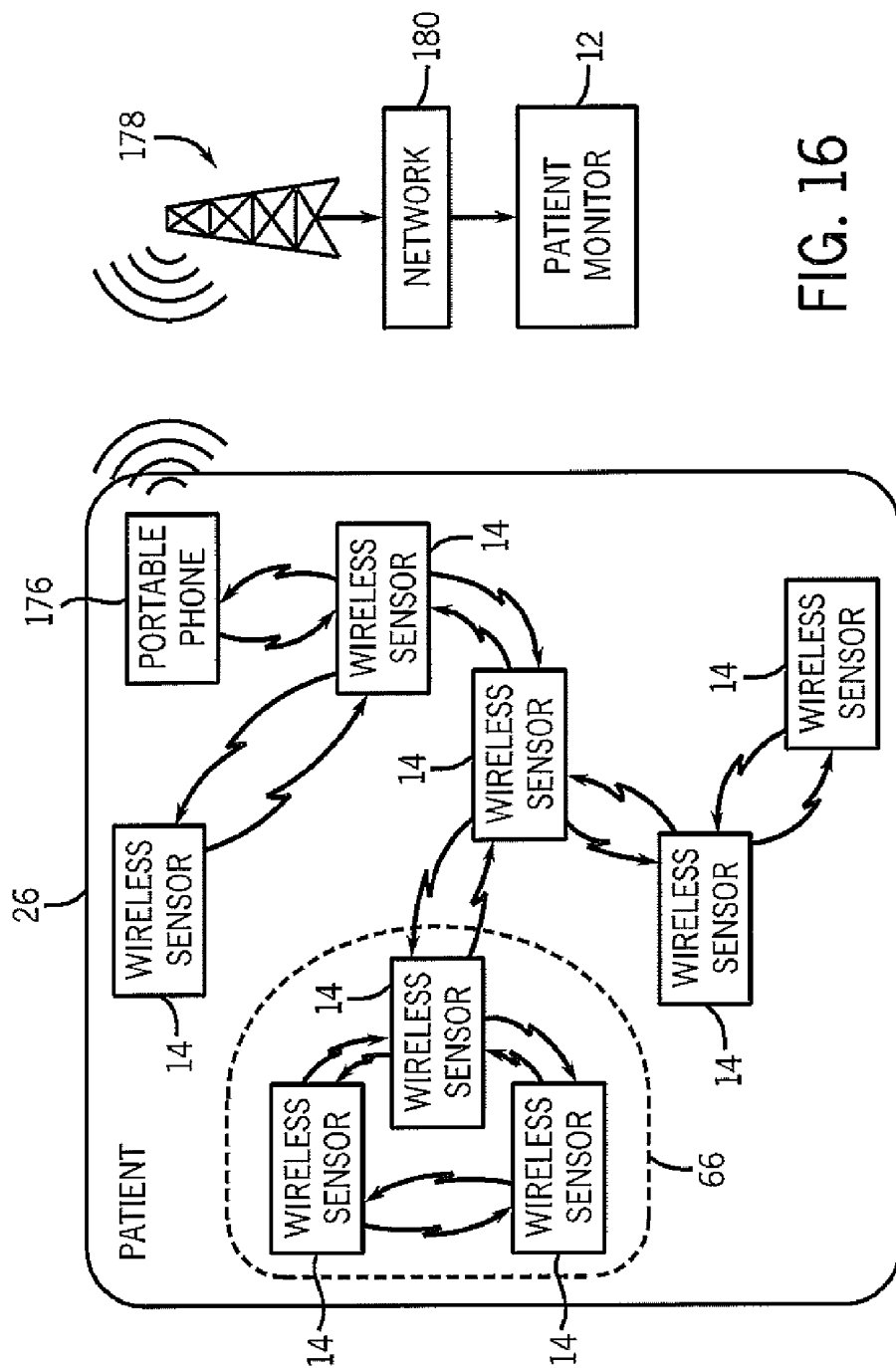

FIG. 16

## ADAPTIVE WIRELESS BODY NETWORKS

### BACKGROUND

[0001] The present disclosure relates generally to medical sensors and, more particularly, to adaptive networks of wireless medical sensors.

[0002] This section is intended to introduce the reader to various aspects of art that may be related to various aspects of the present disclosure, which are described and/or claimed below. This discussion is believed to be helpful in providing the reader with background information to facilitate a better understanding of the various aspects of the present disclosure. Accordingly, it should be understood that these statements are to be read in this light, and not as admissions of prior art.

[0003] In certain medical settings, many medical sensors may monitor a patient. Such sensors may include, for example, photoplethysmographic sensors, temperature sensors, respiration bands, blood pressure sensors, electrocardiogram (ECG) sensors, electroencephalogram (EEG) sensors, pulse transit time sensors, and so forth. These medical sensors generally may communicate with a local patient monitor or a network using a communication cable. However, the use of communication cables may limit the range of applications available, as the cables may become prohibitively expensive at long distances and may physically tether a patient to a monitoring device, thereby limiting the patient's range of motion. Though wireless medical sensors may transmit information without need of a communication cable, many wireless medical sensors may employ large batteries that are cumbersome, uncomfortable to wear, and expensive.

### SUMMARY

[0004] Certain aspects commensurate in scope with the originally claimed embodiments are set forth below. It should be understood that these aspects are presented merely to provide the reader with a brief summary of certain forms the embodiments might take and that these aspects are not intended to limit the scope of the presently disclosed subject matter. Indeed, the embodiments may encompass a variety of aspects that may not be set forth below.

[0005] Present embodiments relate to systems, methods, and devices for obtaining physiological measurements of a patient using an adaptive body network. In one example, a wireless medical sensor may include physiological sensor circuitry, wireless transceiver circuitry, and control circuitry. The physiological sensor circuitry may be capable of obtaining a physiological measurement of a patient. The wireless transceiver circuitry may be capable of joining a wireless web that includes at least one other wireless medical sensor, through which the wireless transceiver circuitry may communicate the physiological measurement to an external device. The control circuitry may be capable of determining a data update rate at which to operate the physiological sensor or the wireless transceiver circuitry, or a combination thereof, based at least in part on a status of the patient.

### BRIEF DESCRIPTION OF THE DRAWINGS

[0006] Advantages of the presently disclosed subject matter may become apparent upon reading the following detailed description and upon reference to the drawings in which:

[0007] FIG. 1 is a perspective view of a wireless web medical sensor system, in accordance with an embodiment;

[0008] FIG. 2 is a block diagram of a wireless sensor and a patient monitor of the wireless web medical sensor system of FIG. 1, in accordance with an embodiment;

[0009] FIGS. 3-5 are schematic views of a wireless finger pulse oximetry sensor having energy harvesting capabilities for use with the system of FIG. 1, in accordance with an embodiment;

[0010] FIG. 6 is a block diagram of a self-assembling wireless web of medical sensors on a patient, in accordance with an embodiment;

[0011] FIG. 7 is a flowchart representing an embodiment of a method for initializing the wireless web of wireless medical sensors of FIG. 6;

[0012] FIG. 8 is a schematic diagram representing certain factors for consideration during the initialization of the wireless web of medical sensors, in accordance with an embodiment;

[0013] FIGS. 9 and 10 are flowcharts representing embodiments of methods for re-initializing the wireless web of medical sensors when communication between a main sensor and/or the patient monitor is lost;

[0014] FIG. 11 is a flowchart representing an embodiment of a method for operating the wireless web of medical sensors;

[0015] FIG. 12 is a schematic diagram representing certain factors for consideration for selecting a data update rate level used during the operation of the wireless web of medical sensors, in accordance with an embodiment;

[0016] FIG. 13 is a block diagram of a self-assembling wireless web of medical sensors that communicates with a patient monitor via a local (e.g., bedside) transceiver, in accordance with an embodiment;

[0017] FIG. 14 is a block diagram of a self-assembling wireless web of medical sensors that communicates with a patient monitor via a wired medical sensor with wireless capabilities, in accordance with an embodiment;

[0018] FIG. 15 is a block diagram of a self-assembling wireless web of medical sensors that communicates with a patient monitor via a personal server, in accordance with an embodiment; and

[0019] FIG. 16 is a block diagram of a self-assembling wireless web of medical sensors that communicates with a patient monitor via a portable device, such as a portable phone, in accordance with an embodiment.

### DETAILED DESCRIPTION

[0020] One or more specific embodiments of the present disclosure will be described below. In an effort to provide a concise description of these embodiments, not all features of an actual implementation are described in the specification. It should be appreciated that in the development of any such actual implementation, as in any engineering or design project, numerous implementation-specific decisions must be made to achieve the developers' specific goals, such as compliance with system-related and business-related constraints, which may vary from one implementation to another. Moreover, it should be appreciated that such a development effort might be complex and time consuming, but would nevertheless be a routine undertaking of design, fabrication, and manufacture for those of ordinary skill having the benefit of this disclosure.

[0021] Embodiments of the present disclosure may apply to a variety of medical sensors, including photoplethysmographic sensors, temperature sensors, respiration bands,

blood pressure sensors, electrocardiogram (ECG) sensors, electroencephalogram (EEG) sensors, pulse transit time sensors, and so forth. These sensors may obtain a variety of physiological measurements based on information detected from patient tissue. Certain medical events may call for monitoring many physiological parameters of a patient using many different medical sensors. Under such conditions, in accordance with embodiments of the present disclosure, many low-power medical sensors may communicate wirelessly with one another to form a wireless web of medical sensors. By forming a wireless web (e.g., a wireless personal area network (WPAN) and/or wireless mesh network of devices) through which to communicate, the medical sensors may conserve power. These low-power wireless medical sensors may be powered by relatively unobtrusive batteries and/or using various energy harvesting techniques, such as piezoelectric energy harvesting, inductive energy harvesting, and/or thermoelectric energy harvesting.

**[0022]** A wireless web of medical sensors, such as those disclosed herein, may efficiently obtain and communicate physiological parameters from a patient to a patient monitor. Specifically, the medical sensors of the wireless web may determine, based on any suitable number of factors, which of the medical sensors should communicate with the patient monitor. In some embodiments, the primary factor of this determination may be the proximity of a given medical sensor to the patient monitor.

**[0023]** Additionally or alternatively, the medical sensors of the wireless web may determine a suitable data update rate level for their operation based on patient physiology and/or other factors. Thus, when measured patient parameters indicate that the patient is healthy, the medical sensor data update rate level may be relatively low, conserving power. In contrast, when the measured patient parameters indicate the patient is suffering a condition or complication, the medical sensor data update rate level may be relatively higher, enabling medical personnel to more closely observe the patient. In some embodiments, the patient monitor may assess these one or more factors to determine the medical sensor data update rate level. The patient monitor may thereafter communicate the determined data update rate level to the wireless web of medical sensors.

**[0024]** With the foregoing in mind, FIG. 1 is a perspective view of a medical sensor system 10 including a patient monitor 12 for use with a wireless web of medical sensors 14. By way of example, embodiments of the system 10 may be implemented with any suitable medical sensors 14 and patient monitor 12, such as those available from Nellcor Puritan Bennett LLC. The medical sensor system 10 may determine a variety of physiological parameters of a patient based on wireless signals received from the medical sensors 14. As illustrated in FIG. 1, the medical sensor system 10 may function with any suitable wireless medical sensors 14 capable of joining a wireless web 16, which may include, for example, photoplethysmographic sensors, temperature sensors, respiration bands, blood pressure sensors, electrocardiogram (ECG) sensors, electroencephalogram (EEG) sensors, pulse transit time sensors, and so forth. Generally, the medical sensors 14 may be relatively low-power devices that receive power from batteries and/or various energy harvesting techniques. Such energy harvesting techniques may include, for example, piezoelectric energy harvesting, inductive energy harvesting, and/or thermoelectric energy harvesting. Certain

embodiments of medical sensors 14 that employ such energy harvesting techniques are described below.

**[0025]** The patient monitor 12 may communicate with the wireless web 16 of medical sensors 14 via a wireless module 18. The wireless module 18 may enable the patient monitor to send and receive wireless communication with the wireless web 16 of medical sensors 14 using any suitable wireless protocol. For example, the wireless module 18 may communicate using the IEEE 802.15.4 standard, which may include, for example, ZigBee, WirelessHART, and/or MiWi. Additionally or alternatively, the wireless module 18 may communicate using the Bluetooth standard or one or more of the IEEE 802.11.x standards. In some embodiments, the wireless module 18 may be capable of optical communication, such as free space optics (FSO), using light emitting diodes (LEDs) and/or laser diodes (LDs). The patient monitor 12 may include a display 20, memory, a processor, and various monitoring and control features. Based on sensor data received from the wireless web 16 of medical sensors 14, the patient monitor 12 may display patient parameters and perform various additional algorithms. Among other things, the patient monitor 12 may process the sensor data to determine a status of the patient and, depending on the status, may indicate a data update rate level at which the medical sensors 14 should operate.

**[0026]** In the presently illustrated embodiment of FIG. 1, the medical sensors 14 may include any suitable wireless sensors capable of joining the wireless web 16. The medical sensors 14 may include photoplethysmographic sensors for placement on various patient body locations, temperature sensors, respiration bands, blood pressure sensors, ECG sensors, EEG sensors, and/or pulse transit time sensors, and so forth. The medical sensors 14 may attach to patient tissue (e.g., a patient's finger, ear, forehead, chest, or toe). By way of example, one of the medical sensors 14 may be a photoplethysmographic sensor that includes an emitter 22 and a detector 24. When attached to pulsatile patient tissue, the emitter 22 may emit light at certain wavelengths into the tissue and the detector 24 may receive the light after it has passed through or has been reflected by the tissue. For example, the emitter 22 may emit light from two or more light emitting diodes (LEDs) or other suitable light sources into the pulsatile tissue. The reflected or transmitted light may be detected by the detector 24, which may be, for example, a photodiode or photo-detector. The amount of light that passes through the tissue, as well as other characteristics of the light, may vary in accordance with the changing amount of certain blood constituents in the tissue and the related light absorption and/or scattering.

**[0027]** Each of the medical sensors 14 may include wireless communication capabilities to enable communication with other wireless medical sensors 14 via such wireless protocols as relate to the IEEE 802.15.4 standard, which may include, for example, ZigBee, WirelessHART, and/or MiWi. Additionally or alternatively, the wireless module 18 may be capable of communicating using the Bluetooth standard or one or more of the IEEE 802.11.x standards. In some embodiments, the wireless module 18 may involve optical communication, such as free space optics (FSO), using light emitting diodes (LEDs) and/or laser diodes (LDs). The sensors 14 may self-assemble into the wireless web 16 by communicating with one another. Based on any suitable factors, the medical

sensors 14 may select one of the medical sensors 14 of the wireless web 16 to serve as a main communication point with the patient monitor 12.

[0028] To conserve power, the medical sensors 14 may operate various data update rate levels depending on the status of the patient. When the patient is healthy, the medical sensors 14 may gather fewer physiological measurements and/or conduct such measurements only occasionally through the wireless web 16 to the patient monitor 12. When the patient suffers from an identified condition or disease, the medical sensors 14 may gather more physiological measurements and/or conduct such measurements more quickly through the wireless web 16 to the patient monitor 12. Techniques related to determining the data update rate level at which to operate are discussed below with reference to FIGS. 11 and 12.

[0029] FIG. 2 is a block diagram of an embodiment of the medical sensor system 10 of FIG. 1. By way of example, embodiments of the system 10 may be implemented with any suitable medical sensors and patient monitor, such as those available from Nellcor Puritan Bennett LLC. The system 10 may include the patient monitor 12 and two or more medical sensors 14, and may obtain, for example, a photoplethysmographic signal, a patient body temperature, a respiration rate, a patient blood pressure, an electrocardiogram (ECG) signal, an electroencephalogram (EEG) signal, and/or pulse transit time, and so forth.

[0030] Each wireless medical sensor 14 may attach to a patient 26. Physiological sensor circuitry 28 in the wireless medical sensor 14 may obtain physiological information from the patient 26. By way of example, if the medical sensor 14 is a photoplethysmographic sensor, the physiological sensor circuitry 28 may include an emitter 22 and a detector 24. The emitter 22 may emit light of certain wavelengths into the patient 26. The detector may detect light that is transmitted or reflected through the patient 26. Regardless of the type of physiological information gathered by the physiological sensor circuitry 28, the physiological sensor circuitry 28 may include amplification, low pass filter, and/or analog-to-digital conversion circuitry that may amplify and digitize raw physiological signals. The resulting digital physiological signals may be processed in the medical sensor 14 or in the patient monitor 12 to obtain physiological parameters related to the patient 26.

[0031] The digital signals output by the physiological sensor circuitry 28 may be stored in memory 30 and/or queued in the wireless module 18 for transmission to a wireless module 18 of the patient monitor 12 or of other wireless medical sensors 14. Control logic 32 or a local microprocessor may control the operation of the wireless medical sensor 14 based at least in part on the meaning of the physiological information detected by the physiological sensor circuitry 28. In certain embodiments, the control logic 32 may control the operation of both the physiological sensor circuitry 28 and the wireless module 18. In certain other embodiments, the physiological sensor circuitry 28 and the wireless module 18 may operate independently of the control logic 32.

[0032] The control logic 32 may carry out certain algorithms regarding the operation of the medical sensor 14. Many such algorithms are discussed in greater detail below with reference to FIGS. 7-12. By way of example, the control logic 32 may assess one or more factors to determine whether the medical sensor 14 is to serve as a main communication point between the other wireless medical sensors 14 of the wireless web 16 and the patient monitor 12, as presently

depicted in FIG. 2. Additionally or alternatively, the control logic 32 may assess one or more factors, including whether the signals from the physiological sensor circuitry 28 indicate a condition or disease, to determine a data update rate level. Based on the determined data update rate level, the control logic 32 may cause the wireless medical sensor 14 to operate in a more power-conservative manner when the patient 26 is healthy and/or stable, and/or to operate in a more active manner when the patient 26 is suffering from a condition or disease and/or is unstable.

[0033] In some embodiments, the control logic 32 and/or a local microprocessor may include processing capabilities for determining data of interest from the raw digital signals from the physiological sensor circuitry 28. Such data of interest may include, for example, SpO<sub>2</sub> readings, pulse rate, measurement of total hemoglobin, and so forth. The data of interest may require substantially less bandwidth for transmission to the patient monitor 12 than the raw digital signals from the physiological sensor circuitry 28. However, processing the raw digital signals to obtain such data of interest may consume a significant amount of power.

[0034] As mentioned above, the wireless medical sensors 14 may be low-power medical sensors that operate on batteries and/or use power obtained from various energy harvesting techniques, such as piezoelectric energy harvesting, inductive energy harvesting, and/or thermoelectric energy harvesting. One such energy harvesting charging device 34 may supply power to a power source 36. A charging control circuit 38 may allow for the adaptive control of wireless energy harvested from the charging device 34. In one embodiment, the power source 36 may include one or more batteries, such as a rechargeable battery that may be user-removable or may be secured within the housing of the sensor 14. Additionally or alternatively, the power source 36 may include one or more capacitors for storage of charge.

[0035] The charging control circuit 38 may, for example, include a processing circuit or control logic that may determine the current level of charge remaining in the power source 36, as well as the current amount of power being harvested by the charging device 34. By way of example, the charging control circuit 38 may determine if the charging device 34 is generating too little power to charge the power source 36. If so, the charging control circuit 38 may provide an indication to the control logic 32 or to the patient monitor 12, via the wireless module 18, that the power supply of the wireless medical sensor 14 is diminishing.

[0036] Each wireless sensor 14 may operate using relatively little power. To reduce the amount of power consumed, the wireless module 18 of each wireless medical sensor 14 may communicate using low-power wireless signals. As such, the wireless medical sensors 14 generally may communicate only with other local wireless medical sensors 14. According to the wireless protocol employed by the wireless module 18, the medical sensors 14 may form a wireless web 16. This wireless web 16 may propagate communication among the wireless medical sensors 14 to a main communication medical sensor 14 that communicates directly with the patient monitor 12. The main communication medical sensor 14 may transmit the physiological information gathered by all the medical sensors 14.

[0037] The digital physiological signals from the many wireless medical sensors 14 may be received by the wireless module 18 of the patient monitor 12, which generally may communicate only with the main communication wireless

medical sensor 14. The wireless module 18 may transfer the received physiological signals to wireless sensor interface circuitry 40 and/or to a bus 42 connected to a general- or special-purpose microprocessor 44. In some embodiments, the microprocessor 44 may issue instructions, such as a particular data update rate level at which to operate, to the wireless medical sensors 14 via the wireless module 18.

[0038] In certain embodiments, the medical sensors 14 may not process the raw physiological signals into data of interest. As such, the wireless sensor interface circuitry 40 may perform initial processing on certain of the raw physiological signals before transferring the output to the bus 42. Among other things, the wireless sensor interface circuitry 40 may separate and identify the signals from the many medical sensors 14 before the signals are processed further by the microprocessor 44.

[0039] The microprocessor 44 on the bus 42 may govern various operations of the patient monitor 12. Such operations may include the determination of various physiological parameters based on data from the medical sensor 14, as well whether the medical sensors 14 should be operating at a higher or lower data update rate level based on a status of the patient 26. A network interface card (NIC) 46 may enable the patient monitor 12 to communicate with external devices on a network. Random access memory (RAM) 48 may provide temporary storage of variables and other data employed while carry out certain techniques described herein, while read only memory (ROM) 50 may store certain algorithms, such as those disclosed herein for ascertaining the data update rate level for the operation of the wireless medical sensors 14. Though nonvolatile storage 52 generally may store long-term data, the nonvolatile storage 52 also may store the algorithms described herein.

[0040] The patient monitor 12 may include other components, such as a display interface 54 and control inputs 56. The display interface 54 may enable the patient monitor 12 to indicate on the display 20 various physiological parameters obtained by the wireless medical sensors 14. Control inputs 56 may enable a physician or other medical practitioner to vary the operation of the patient monitor 12.

[0041] As noted above, the wireless medical sensors 14 may utilize charging devices 34 to harvest energy. FIGS. 3-5 represent embodiments of wireless medical sensors 14 that employ varying configurations of charging devices 15. FIG. 3 illustrates various placement locations of one or more charging devices 34 in conjunction with a medical sensor 14. In the embodiment of FIG. 6, the medical sensor 14 may be utilized in conjunction with a finger of a patient 26. As may be seen, an emitter 22 and a detector 24 (representing externally visible components of the physiological sensor circuitry 28), as well as the wireless module 18 are illustrated as elements of the medical sensor 14. As depicted, the emitter 22 and detector 24 may be arranged in a reflectance-type configuration in which the emitter 22 and detector 24 are typically placed on the same side of the sensor site. Reflectance type sensors may operate by emitting light into the tissue (e.g., the finger of the patient 26) and detecting the reflected light that is transmitted and scattered by the tissue. That is, reflectance type sensors detect light photons that are scattered back to the detector 24. The medical sensor 14 may alternatively be configured as a transmittance type sensor whereby the emitter 22 and detector 24 are typically placed on differing sides of the sensor site.

In this manner, the detector 24 may detect light that has passed through one side of a tissue site to an opposite side of the tissue site.

[0042] As illustrated in FIG. 3, the medical sensor 14 may also include one or more charging devices 34. The charging devices 34 may include, for example, piezoelectric energy harvesters, inductive energy harvesters, and/or thermoelectric energy harvesters. In one embodiment, a charging device 34 may be located on a top side of the sensor 14. Additionally and/or alternatively, a charging device 34 may be located on the bottom side of the medical sensor 14. Each of these charging devices 34 may be integrated into the medical sensor 14, or affixed thereto. Furthermore, these charging devices 34 may operate independently, or may be electrically coupled to one another to increase the overall energy that may be harvested for use by the medical sensor 14. Additionally, one or more charging stations 34 external to the medical sensor 14 may be utilized.

[0043] FIG. 4 illustrates an embodiment whereby the charging device 34 is located externally from the medical sensor 14. As illustrated, the charging device 34 may be attached to the medical sensor 14 via a lead 58. The lead 58 may be an electrical conductor, such as a power cable, that transmits harvested power to the medical sensor 14. The lead 58 may terminate with the charging device 34 which may be integrated into (or be attached to) a bracelet 60. The bracelet 60 may be, for example, a medical bracelet. Furthermore, the lead 58 may be connected to and separated from the charging device 34. That is, the lead 58 may be separable (i.e., releasable) from the charging device 34, the bracelet 60, and/or the medical sensor 14. Alternatively, the lead 58 may be permanently affixed to the charging device 34 and/or the bracelet 60. Regardless, by separating the charging device 34 from the medical sensor 14, more available area in the bracelet 60 may be available for harvesting of energy. That is, with greater area available for the charging device 34, a greater number of energy harvesters in the charging device 34 may be utilized, thus increasing the overall amount of energy that may be harvested.

[0044] FIG. 5 illustrates a second embodiment whereby the charging device 34 may be located externally from the medical sensor 14. As illustrated, the charging device 34 may be attached to the medical sensor 14 via a lead 62. The lead 62 may be an electrical conductor, such as a power cable, that transmits power to the medical sensor 14 and may terminate with the charging device 34 which may be integrated into (or be attached to) a garment 64. Again, the lead 62 may be separable (i.e., releasable) from the charging device 34, the garment 64, and/or the medical sensor 14. The garment 64 may be, for example, a shirt or a sleeve of a shirt. The use of the a garment 64 to house the charging device 34 may allow for the charging device 34 to be expanded in size, or for more than one charging devices 34 to be utilized in conjunction, while still allowing for the garment 64 to be comfortably worn. Thus a greater number of energy harvesters may be utilized, which may increase the overall amount of energy that may be harvested. Additionally, by utilizing a large area, such as the garment 64, movements of the patient 26 across a plurality of regions of the patient 26 may be utilized to harvest energy. That is, movements in the chest, arms, etc. of the patient 26 may be translated into power for use by the medical sensor 14. In this manner, a greater number of movements of the patient 26 may be harvested into power for use with the medical sensor 14.

[0045] Such low-power wireless medical sensors **14** may self-assemble into a wireless web **16** on a patient **26**, as shown in FIG. 6. Each wireless medical sensor **14** of the wireless web **16** may convey information from one local sensor **14** to another local sensor **14**, propagating information to and from the patient monitor **12** using such a wireless protocol as may relate to the IEEE 802.15.4 standard, which may include, for example, ZigBee, WirelessHART, and/or MiWi. Additionally or alternatively, the medical sensors **14** may be capable of communicating using the Bluetooth standard or one or more of the IEEE 802.11.x standards. In some embodiments, the wireless communication may involve optical communication, such as free space optics (FSO), using light emitting diodes (LEDs) and/or laser diodes (LDs). Generally, only one of the medical sensors **14** of the wireless web **16** may communicate with the patient monitor **12** at any given time. Moreover, the medical sensors **14** may generally only communicate using low-power signals to other nearby medical sensors **14**. In this way, the medical sensors **14** of the wireless web **16** may conserve power.

[0046] As discussed below, the wireless web **16** of medical sensors **14** may self-assemble by determining which medical sensor **14** may communicate with the patient monitor **12**. The control logic **32** of each wireless medical sensor **14** may consider one or more factors to decide whether that medical sensor **14** should be the main communication point for the wireless web. Moreover, as conditions change (e.g., as the patient **26** rotates with respect to the patient monitor **12** or as power supplies vary in certain sensors **14**), the sensors **14** of the wireless web **16** may select a new medical sensor **14** to serve as the main point of communication with the patient monitor **12**. Embodiments of methods for determining which medical sensor **14** should serve as the main point of communication are described below with reference to FIGS. 7-10.

[0047] In the same manner, certain wireless sensors **14** may form a node **66**. The medical sensors **14** of the node **66** may select one of the medical sensors **14** of the node **66** to serve as a main communication point with the rest of the wireless web **16**. Forming a node **66** of medical sensors **14** may be useful, for example, if the sensors **14** of the node **66** generally operate at a higher or lower data update rate level or a different synchronization from than the rest of the medical sensors **14** of the wireless web **16**. Under such conditions, most of the sensors **14** of the node **66** may operate at a single synchronization or data update rate level, and only one sensor **14** may operate with both the sensors **14** of the node **66** and the rest of the wireless web **16**, thereby conserving power among most of the medical sensors **14** of the node **66**.

[0048] As discussed below, the wireless medical sensors **14** may conserve power by operating at a data update rate level dependent on a status of the patient **26**. Although the data rate employed by a medical sensor **14** may remain constant (e.g., 100 kbps) or may vary based on the wireless protocol and/or signal to noise ratio (SNR), the data update rate level (e.g., update once every second, once every 30 seconds, or once every minute, and so forth) may change based on the status of the patient **26**. For example, the data update rate level may be lower when the patient **26** is stable and/or healthy, and the data update rate level may be higher when the patient **26** is unstable and/or has a condition or disease. When the data update rate level is relatively low, the wireless medical sensors **14** of the wireless web **16** may deactivate for periods of time. The medical sensors **14** may awake at coordinated and/or synchronized times to take physiological measurements

and communicate such measurements through the wireless web **16** to the patient monitor **12**. It should be noted, however, that the times during which the medical sensors **14** are awake may be coordinated such that not all of the medical sensors **14** are awake at the same time, which could create data traffic problems as all of the medical sensors **14** may attempt to transmit at the same time. When the data update rate level is relatively high, the wireless medical sensors **14** may deactivate for relatively shorter periods of time, or may not deactivate at all. Embodiments of methods for determining such a data update rate level is described below with reference to FIGS. 11 and 12.

[0049] FIG. 7 depicts a flowchart **68**, which describes an embodiment of a method for initializing the wireless web **16** of medical sensors **14**. In a first step **70**, several wireless medical sensors **14** that have been placed on a patient **26** may discover one another and establish wireless communication to each other and/or with the patient monitor **12** via wireless modules **18**. The wireless medical sensors **14** may synchronize their operating times such that communication may take place for all the sensors **14** at approximately but not necessarily the same time, to avoid collisions in data transmission. In this way, the medical sensors **14** may conserve power spent on wireless communication.

[0050] In step **72**, each medical sensor **14** or a subset of the medical sensors **14** of the newly formed wireless web **16** may assess one or more communication factors. As described below with reference to FIG. 8, these communication factors may include, for example, the proximity of the sensor **14** to the patient monitor **12**, the selection of a button or switch on the medical sensor **14**, a charge level of the power source **36**, an instruction from the patient monitor **12**, and/or a signal quality of communication to and from the sensor **14**. In decision block **74**, each medical sensor **14** or the subset of the medical sensors **14** may weigh the assessed factors to ascertain whether it should serve as the main communication medical sensor **14**. In some embodiments, the medical sensors **14** may also provide an indication of the assessed factors to the rest of the wireless web **16**. The assessments by other medical sensors **14** of the wireless web **16** may also affect the determination made by each medical sensor **14** or the subset of medical sensors **14**.

[0051] If the assessed factors indicate to a medical sensor **14** that it should not serve as the main communication medical sensor **14**, the medical sensor **14** may begin operating at a default data update rate level as an ordinary member of the wireless web **16**. As such, in step **76**, the medical sensor **14** may begin to take periodic physiological measurements. In step **78**, the medical sensor **14** may communicate those measurements through the wireless web **16** to the main communication sensor **14**. As such, the medical sensor **14** may also forward messages received from other medical sensors **14** of the wireless web **16**. However, it should be noted that if a medical sensor **14** is used to forward messages from other medical sensors **14**, it may be listening and thus awake at all times, at the cost of power consumption.

[0052] If the assessed factors indicate to a medical sensor **14** that it should serve as the main communication medical sensor **14**, the medical sensor **14** may, in step **80**, communicate as such to the other sensors **14** of the wireless web **16**. In step **82**, the medical sensor **14** may begin operating at a default data update rate level as the main communication medical sensor **14** of the wireless web **16**. As such, the medical sensor **14** may begin to take periodic physiological mea-

surements. In step 84, the medical sensor 14 may receive physiological measurements from other medical sensors 14. In step 86, the medical sensor 14 may communicate all of the measurements to the patient monitor 12.

[0053] FIG. 8 represents a factor diagram 88 listing communication factors 90 that may be considered by the medical sensors 14 in step 72 of the flowchart 68 of FIG. 7. The communication factors 90 listed in FIG. 8 are intended to be exemplary and not exclusive, and the particular communication factors 90 considered by the medical sensor 14 may be predetermined or may be selected based on a current status of a patient 26.

[0054] A first factor 92 of the communication factors 90 may relate to the proximity of the medical sensor 14 to the patient monitor 12. The medical sensor 14 may assess the proximity of the patient monitor 12 based on the received signal strength of a wireless signal from the wireless module 18 of the patient monitor 12. Additionally or alternatively, the medical sensor 14 may be programmed with an indication of its intended body location placement, and may estimate its proximity to the patient monitor 12 based on, for example, how close to the medical sensor 14 should be to the outer regions of the patient.

[0055] A second factor 94 of the communication factors 90 may include whether a button or switch on a medical sensor 14 has been activated by a clinician. A clinician may do so, for example, to indicate that the medical sensor 14 is located nearby to the patient monitor 12.

[0056] A third factor 96 of the communication factors 90 may be the current charge level of the power source 36. The current charge level may be ascertained by the control logic 32 by way of a message from the charging control circuitry 38. A higher charge level may indicate that the medical sensor 14 may be able to tolerate the increased power consumption that may occur with longer-range wireless communication with the patient monitor 12.

[0057] A fourth factor 98 of the communication factors 90 may be an instruction from the patient monitor 12. In some embodiments, the patient monitor 12 may determine which of the medical sensors 14 of the wireless web 16 should be the main point of communication, based on the one or more of the communication factors 90 or other considerations. By way of example, the patient monitor 12 may instruct the wireless web 16 to rotate which medical sensor 14 serves as the main communication sensor 14, which may result in a more evenly distributed consumption of power among the medical sensors 14.

[0058] A fifth factor 100 of the communication factors 90 may be the signal quality of wireless communication to and from a particular wireless medical sensor 14. For example, if the medical sensor 14 closest to the patient monitor 12 has difficulties establishing connections between other medical sensors 14 of the wireless web 16, a different medical sensor 14 should most likely serve as the main communication sensor 14.

[0059] Occasionally, after the wireless web 16 has been established and the medical sensors 14 are operating in a normal fashion, the main communication sensor 14 may lose communication with the patient monitor 12 or the rest of the wireless web 16. Turning to FIG. 9, a flowchart 110 represents an embodiment of a method for reestablishing communication when, as shown in step 112, the main communication sensor 14 has lost communication with the patient monitor 12. In step 114, the main communication sensor 14 may

indicate as such to the other medical sensors 14 of the wireless web 16. In step 116, the medical sensors 14 of the wireless web 16 may determine a new main communication sensor 14 in an effort to reestablish communication with the patient monitor 12. Step 116 may take place in substantially the same manner as step 72 and decision block 74 of the flowchart 68 of FIG. 7.

[0060] FIG. 10 illustrates a flowchart 118 of an embodiment of a method for reestablishing communication when, as shown in step 120, the main communication sensor 14 has lost communication with the other medical sensors 14 of the wireless web 16. In step 122, the other medical sensors 14 of the wireless web 16 may ascertain that such communication has been lost, and may determine a new main communication sensor 14 in an effort to reestablish communication with the patient monitor 12. Step 122 may take place in substantially the same manner as step 72 and decision block 74 of the flowchart 68 of FIG. 7.

[0061] FIG. 11 is a flowchart 124 of an embodiment of a method for operating the medical sensors 14 of the wireless web 16 to conserve power. Instructions for performing the method of the flowchart 124 may be stored in the memory 30 and/or carried out by the control logic 32 of each medical sensor 14. In general, the flowchart 124 may begin after a period in which the medical sensor 14 has been periodically deactivated to save power.

[0062] In a first step 126, each medical sensor 14 may individually awaken periodically. The period may depend upon, for example, the current data update rate level employed by the medical sensors 14. As noted above and described in greater detail below, the data update rate level may be based on a current status of a patient 26. Because communication among the many wireless medical sensors 14 generally may be synchronized, all of the medical sensors 14 of the wireless web 16 may awaken at the same time. In step 128, the medical sensors 14 may obtain a physiological measurement of the patient 26 and, in step 130, the medical sensors 14 may communicate their measurements through the wireless web 16 to the patient monitor 12. Step 130 may also include other inter-sensor wireless communication, which may ensure that the wireless modules 18 of the sensors 14 remain synchronized and/or which may propagate instructions from the patient monitor 12.

[0063] The wireless medical sensors 14 may occasionally enter a process 132 to evaluate the data update rate level at which to operate. Generally, the process 132 may not occur every time that the medical sensors 14 awaken and carry out wireless communication. Instead, the process 132 may take place periodically or when the measured physiological parameters of step 128 indicate that the patient 26 is becoming less stable. Additionally or alternatively, the process 132 may occur not on the individual wireless medical sensors 14, but rather on the patient monitor 12.

[0064] In the first step of the process 132, step 134, one or more data update rate level factors may be considered. Exemplary data update rate level factors are described in greater detail below with reference to FIG. 12. In step 136, based on the assessment of step 134, the medical sensors 14 may determine an appropriate data update rate level at which to operate. In step 138, the medical sensors 14 may communicate among one another their determinations. In certain embodiments, based on the communication of step 138, all of the medical sensors 14 may select the highest data update rate level determined by any of the other medical sensors 14. In other

embodiments, the medical sensors **14** may operate at different data update rate levels, but each medical sensor **14** may store in their respective memories **30** the data update rate levels at which other local medical sensors **14** may operate.

**[0065]** Regardless of whether the process **132** takes place, in step **140**, the medical sensors **14** may deactivate for a period of time that depends on the data update rate level. For example, if the data update rate level is relative low, the period of time may be relatively long. If the data update rate level is relatively high, the period of time may be relatively short. By way of example, the period of inactivity may be 1 second, 2 seconds, 5 seconds, 10 seconds, 30 seconds, 1 minute, 2 minutes, 5 minutes, 10 minutes, 30 minutes, 1 hour, 2 hours, 5 hours, etc. In certain embodiments, when the data update rate level is sufficiently high, the wireless medical sensors **14** may not deactivate. Following the period of deactivation, the medical sensors **14** may reawaken and repeat the flowchart **124**.

**[0066]** As described above, in the first step **134** of the process **132**, the wireless medical sensors **14** or the patient monitor **12** may assess one or more factors to determine the data update rate level. FIG. **12** represents a factor diagram **142** listing such data update rate level factors **144**. The data update rate level factors **144** listed in FIG. **12** are intended to be exemplary and not exclusive, and the particular data update rate level factors **144** considered by the medical sensors **14** or patient monitor **12** may be predetermined or may be selected based on a current status of the patient **26**. The considered factors may be weighted and/or scored, and the data update rate level may reflect a total weighted and/or scored value of the considered factors.

**[0067]** A first factor **146** of the data update rate level factors **144** may be a current value of a physiological measurement obtained in step **128**. By way of example, the control logic **32** may be capable of sampling all or a portion of the digital signal provided by the physiological sensor circuitry **28**. If so, the control logic **32** may occasionally sample the physiological measurement, storing the sampled measurement into the memory **30**. If the sampled measurement is within a predetermined acceptable range of values, the factor **146** may weigh in favor of a comparatively lower data update rate level. If the sampled measurement is higher or lower than the predetermined acceptable range of values, the factor **146** may weigh in favor of a comparatively higher data update rate level.

**[0068]** By way of example, if the sampled measurement includes a respiration rate, a predetermined acceptable range of values for an adult patient may be a range of 12 to 20 breaths per minute. A respiration rate less than 12 breaths per minute or greater than 20 breaths per minute may weigh in favor of a higher data update rate level. In determining the data update rate level based at least in part on the factor **146**, the control logic **32** may further consider how much the value of the sampled measurement varies beyond the predetermined acceptable range. In other words, the more the sampled value varies from the predetermined acceptable range, the more the factor **146** may weigh in favor of a higher data update rate level.

**[0069]** A second factor **148** of the data update rate level factors **144** may be the historical stability of recently sampled physiological measurements. If the sampled measurement is within a predetermined variability threshold over a recent historical period (e.g., 5 minutes), the factor **148** may weigh in favor of a relatively lower data update rate level. If the

sampled measurement varies beyond the predetermined variability threshold, the factor **148** may weigh in favor of a relatively higher data update rate level. In determining the data update rate level based at least in part on the factor **148**, the microprocessor **38** may further consider how much the sampled measurement has varied. For example, the greater the variability of the sampled measurement, the more the factor **148** may weigh in favor of a higher data update rate level.

**[0070]** A third factor **150** of the data update rate level factors **144** may be physiological measurements obtained by other medical sensors **14** of the wireless web **16**. Such physiological measurements may be sampled and transmitted from one or more medical sensors **14** to other medical sensors **14** of the wireless web **16** for purposes of performing the assessment of step **134**. Additionally or alternatively, each medical sensor **14** may sample measurements from other sensors as the measurements are propagated through the wireless web **16** toward the patient monitor **12**.

**[0071]** Like the factors **146** and/or **148**, if sampled physiological measurements from the other medical sensors **14** exceed a predetermined acceptable range of variability over a recent historical period, or if an absolute value exceeds a predetermined acceptable range of values, the factor **150** may weigh in favor of a higher data update rate level. Similarly, if the measurements from other sensors **14** remain within the predetermined acceptable range of variability over the recent historical period, or if the absolute value does not exceed the predetermined acceptable range of values, the factor **150** may weigh in favor of a lower data update rate level.

**[0072]** By way of example, if one of the medical sensors **14** is a temperature sensor, and a current patient temperature falls outside a predetermined acceptable range of values (e.g., a range of between 97.6° F. and 99.6° F.), the other medical sensors **14** may interpret the factor **150** as weighing in favor of a higher data update rate level. Also like the factors **88** and/or **90**, in determining the data update rate level based at least in part on the factor **150**, the medical sensors **14** may also consider how much the other sensor measurements have varied over time or how much the absolute value of the other sensor measurements vary beyond the predetermined acceptable ranges.

**[0073]** Express instructions received by the wireless web **16** of medical sensors **14** from the patient monitor **12** may constitute a fourth factor **152** of the data update rate level factors **144**. As discussed above, the patient monitor **12** may occasionally transmit instructions the wireless medical sensors **14** of the wireless web **16**. These instructions may indicate a particular data update rate level at which to operate, as determined by the patient monitor **12** or by a clinician. To provide one example, by pressing a button on the patient monitor **12**, medical personnel may cause the patient monitor **12** to instruct the wireless medical sensor **14** to operate continuously without deactivating, which may represent the highest data update rate level observed by the wireless web **16** of medical sensors **14**.

**[0074]** A fifth factor **154** of the data update rate level factors **144** may be the data update rate level determined by other medical sensors **14**. By way of example, if one medical sensor **14** determines a relatively higher data update rate level, other medical sensors **14** may weigh the factor **154** in favor of a higher data update rate level. However, in some embodiments, if one medical sensor **14** determines a relatively lower

data update rate level, other medical sensors **14** may not weigh the factor **154** in favor of either a higher or lower data update rate level.

[0075] A sixth factor **156** of the data update rate level factors **144** may be a press of a button or switch on the wireless medical sensor **14**. If the button or switch is a single button and the button is pressed, the factor **156** may weigh in favor of a higher data update rate level. Similarly, if the button or switch is a switch with two or more settings (e.g., low, medium, high, etc.), the setting to which the button or switch has been moved may correspondingly weigh in favor of higher or lower data update rate levels, as appropriate. For example, because pressing the button or switch may cause the factor **156** to weigh in favor of a higher data update rate level, pressing the button or switch may result in the continuous operation of the medical sensors **14** of the wireless web **16**.

[0076] A seventh factor **158** of the data update rate level factors **144** may be the current location of the patient **26**, which may be indicated to the wireless medical sensors **14** via the patient monitor **12**. Because the amount of data from the wireless medical sensors **14** that should be supplied to the patient monitor **12** may vary depending on whether the patient **26** is in surgery, in recovery, or undergoing other tests, the current location of the patient **26** may be considered as one of the data update rate level factors **144**. Thus, if the patient **26** is currently located in a medical facility room where the patient **26** should be kept under especially close scrutiny, such as an operating room, the factor **158** may weigh in favor of a correspondingly higher data update rate level. If the patient **26** is currently located in a medical facility room where the patient **26** may be kept under less scrutiny, such as a recovery room, the factor **158** may weigh in favor of a lower data update rate level.

[0077] In determining the data update rate level based at least in part on the factor **158**, the medical sensors **14** may give different locations different weights in favor of a higher or lower data update rate level. For example, if the current location is a testing room, such as a CT room, the factor **158** may weigh in favor of a comparatively higher data update rate level. However, the factor **158** may weigh even more heavily in favor of a higher data update rate level if the current location of the patient **26** is the operating room. Similarly, the sensors **14** may be instructed to stop transmitting data or use a very low data update rate level if the patient **26** is located in close proximity to an instrument which is sensitive to wireless interference. In such a case, if the sensors **14** include frequency hopping capabilities, the sensor **14** may select an alternate frequency or channel that does not interfere with nearby equipment or other sensors **14** located on other patients **26**. In this way, data from a critically ill patient **26** or patient **26** in an operating room may be prioritized higher than patients **26** who are relatively stable.

[0078] An eighth factor **160** of the data update rate level factors **144** may be the presence or the absence of a clinician proximate to the patient **26**, which may be supplied to the wireless medical sensors **14** via the patient monitor **12**. For example, if a clinician enters a room where the patient **26** is currently located, the factor **160** may weigh in favor of a comparatively higher data update rate level. If the clinician exits the room, the factor **160** may weigh in favor of a comparatively lower data update rate level. In determining the data update rate level based at least in part on the factor **160**, the medical sensors **14** may weigh the factor **160** more heavily in favor of a higher or lower data update rate level

based on the number or patient assignment of clinicians present. For example, if a clinician that is not assigned to the patient **26** enters a room where the patient **26** is currently located, the factor **160** may not weigh as heavily in favor of a higher data update rate level as when a clinician that is assigned to the patient **26** enters the room.

[0079] A ninth factor **162** of the data update rate level factors **144** may be the movement of the patient **26**, which may be indicated to the wireless medical sensors **14** via the patient monitor **12**. Additionally or alternatively, if one of the medical sensors **14** includes a movement sensor, such as an accelerometer, an indication of patient **26** movement may be propagated through the wireless web **16**. If the patient **26** is currently moving, indicating that the patient **26** is not at rest or is being moved from one room to another, the factor **162** may weigh in favor of a comparatively higher data update rate level. If the patient **26** is not currently moving, the factor **162** may weigh in favor of a comparatively lower data update rate level. Additionally, the amount of current patient movement may further affect the weight of the factor **162** in favor of a comparatively higher or lower data update rate level. In another example, transmission of the heart rate of the patient **26** may be suppressed if an accelerometer detects excessive motion artifact, and the calculated heart rate may be less likely to be accurate than a previous value.

[0080] A tenth factor **164** of the data update rate level factors **144** may be an initialization status of the wireless medical sensors **14**. For a predetermined period of time while the wireless web **16** of sensors **14** is being initialized (e.g., 5 minutes), the data update rate level of the sensors **14** may be temporarily increased dramatically, such that the medical sensors **14** do not deactivate to save power. By supplying a raw data stream during the initialization of the wireless web **16**, a clinician or other medical personnel may properly fit the medical sensors **14** to the patient **26**.

[0081] An eleventh factor **166** of the data update rate level factors **144** may be an amount of power remaining in the power sources **36** of the wireless medical sensors **14**. If the power sources **36** of the sensors **14** have more than a certain amount of remaining power, the factor **166** may weigh in favor of a comparatively higher data update rate level. If the power sources **36** have less than the predetermined amount of remaining power, the factor **166** may weigh in favor of a comparatively lower data update rate level. This factor **166** may also account for the transmit power required to send error-free data at the last update. For instance, when the patient **26** is relatively far from the receiver of the patient monitor **12**, more transmit power may be required, so less frequent updates may take place, especially at lower power source **36** reserves.

[0082] FIGS. 13-16 represent alternative embodiments of the configuration of the wireless web **16** of medical sensors **14**. FIG. 13 illustrates an embodiment in which a local transceiver **170** receives communication from a main communication sensor **14** of the wireless web **16** of medical sensors **14**. In the embodiment of FIG. 13, a number of the wireless medical sensors **14** may form a wireless web **16** while attached to a patient **26**. In some embodiments, certain sensors **14** may form a separate node **66**.

[0083] The main communication medical sensor **14**, which generally may be the sole medical sensor **14** that communicates wirelessly with devices outside of the wireless web **16**, may not communicate directly with a wireless module **18** integrated into the patient monitor **12**, but may rather com-

municate wirelessly with the local transceiver 170. The local transceiver 170 may facilitate communication between the main communication medical sensor 14 and the patient monitor 12 using a wired or wireless connection to the patient monitor 12. Because the local transceiver 170 may be placed nearby to a patient 26 and/or placed in or integrated into a medical bed in which the patient 26 rests, the main communication medical sensor 14 may consume a reduced amount of power due to a reduced transmission distance for wireless communication.

[0084] FIG. 14 illustrates an embodiment in which a wired medical sensor 172 having wireless capabilities may receive communication from the wireless web 16 of medical sensors 14. In the embodiment of FIG. 14, a number of the wireless medical sensors 14 may form a wireless web 16 while attached to a patient 26. In some embodiments, certain sensors 14 may form a separate node 66. Instead of communicating with the patient monitor 12 via a main communication medical sensor 14, the wireless web 16 of medical sensors 14 may instead communicate with the wired medical sensor 172. In some embodiments, the wireless web 16 may determine a main communication medical sensor 14 for communication with the wired medical sensor 172. The wired medical sensor 172 may have essentially the same wireless capabilities as the wireless medical sensors 14, but may maintain a wired connection to the patient monitor 12. In this way, the medical sensors 14 of the wireless web 16 may consume a reduced amount of power due to a reduced transmission distance for wireless communication.

[0085] FIG. 15 illustrates an embodiment in which a personal server 174 having wireless capabilities may receive communication from the wireless web 16 of medical sensors 14. In the embodiment of FIG. 15, a number of the wireless medical sensors 14 may form a wireless web 16 while attached to a patient 26. In some embodiments, certain sensors 14 may form a separate node 66. Instead of communicating with the patient monitor 12 via a main communication medical sensor 14, the wireless web 16 of medical sensors 14 may instead communicate with the personal server 174. The personal server 174 may facilitate communication between the wireless web 16 and the patient monitor 12.

[0086] The personal server 174 may receive low-power communication from the wireless web 16 of medical sensors 14, and may communicate with the patient monitor 12 with higher-power communication. In some embodiments, the wireless web 16 may determine a main communication medical sensor 14 for communication with the personal server 174. Also, in some embodiments, the personal server 174 may communicate with the wireless web 16 using a relatively lower-power wireless protocol, such as those associated with the 802.15.4 IEEE standard, but may communicate with the patient monitor 12 using a relatively higher-power protocol, such as Bluetooth or those protocols associated with the 802.11.x IEEE standard.

[0087] Because the personal server 174 may not expend any power obtaining physiological measurements of the patient 26, the personal server 174 may, in some embodiments, receive power by way of the various energy harvesting techniques discussed above. Additionally or alternatively, the personal server 174 may rely primarily on battery power. Also, in some embodiments, the personal server 174 may perform certain processing of the raw physiological measurements obtained by the medical sensors 14 of the wireless web 16. For example, the personal server 174 may process certain

of the raw physiological measurements to obtain data of interest related to a specific physiological parameter of the patient 26 (e.g., SpO<sub>2</sub>, pulse rate, total hemoglobin, and so forth), which may be sent to the patient monitor 12 in lieu of the raw physiological measurements.

[0088] FIG. 16 illustrates an embodiment in which a portable phone 176 may receive communication from the wireless web 16 of medical sensors 14. In the embodiment of FIG. 16, a number of the wireless medical sensors 14 may form a wireless web 16 while attached to a patient 26. In some embodiments, certain sensors 14 may form a separate node 66. Instead of communicating with the patient monitor 12 via a main communication medical sensor 14, the wireless web 16 of medical sensors 14 may instead communicate with the portable phone 176. The portable phone 176 may facilitate communication between the wireless web 16 and the patient monitor 12 by conveying messages through a cellular network 178 and/or a secondary network 180, such as the Internet. Thus, in at least some embodiments, the portable phone 176 may be understood to be a cellular telephone.

[0089] The portable phone 176 may receive low-power communication from the wireless web 16 of medical sensors 14, and may communicate with the patient monitor 12 with higher-power communication. In some embodiments, the wireless web 16 may determine a main communication medical sensor 14 for communication with the portable phone 176. In certain embodiments, the main communication medical sensor 14 may communicate with the wireless web 16 using a relatively lower-power wireless protocol, such as those associated with the 802.15.4 IEEE standard, but may communicate with the portable phone 176 using a relatively higher-power protocol, such as Bluetooth or those protocols associated with the 802.11.x IEEE standards. Also, in some embodiments, the medical sensors 14 of the wireless web 16 may communicate with the portable phone 176 using Bluetooth or similar protocols, and the portable phone 176 may take the place of the main communication medical sensor 14 in the wireless web 16.

[0090] While the embodiments set forth in the present disclosure may be susceptible to various modifications and alternative forms, specific embodiments have been shown by way of example in the drawings and have been described in detail herein. However, it should be understood that the disclosure is not intended to be limited to the particular forms disclosed. The disclosure is to cover all modifications, equivalents, and alternatives falling within the spirit and scope of the disclosure as defined by the following appended claims.

What is claimed is:

1. A wireless medical sensor comprising:
  - physiological sensor circuitry capable of obtaining a physiological measurement of a patient;
  - wireless transceiver circuitry capable of joining a wireless web comprising at least one other wireless medical sensor and communicating the physiological measurement through the wireless web to an external device; and
  - control circuitry capable of determining a data update rate at which to operate the physiological sensor or the wireless transceiver circuitry, or a combination thereof, based at least in part on a status of the patient.
2. The wireless medical sensor of claim 1, wherein the physiological sensor circuitry comprises a photoplethysmographic sensor, a temperature sensor, a respiration band, a blood pressure sensor, an electrocardiogram (ECG) sensor,

an electroencephalogram (EEG) sensor, or a pulse transit time sensor, or any combination thereof.

3. The wireless medical sensor of claim 1, wherein the wireless transceiver circuitry is capable of communicating using a protocol based on the IEEE 802.15.4 standard; the IEEE 802.11.x standards; the Bluetooth standard; or an optical communication protocol; or any combination thereof.

4. The wireless medical sensor of claim 1, wherein the control circuitry is capable of determining the data update rate based at least in part on a data update rate level factor associated with the status of patient, wherein the data update rate level factor comprises a value of the physiological measurement; a historical stability of physiological measurements obtained by the physiological sensor circuitry; a value of another physiological measurement obtained by another medical device; a historical stability of other physiological measurements obtained by the other medical device; an instruction from the external device; a button press or switch setting on the wireless medical sensor; a current location of the patient; a current location of a clinician; a movement of the patient; an initialization status of the wireless medical sensor; a data update rate determined by the at least one other wireless medical sensor; or a remaining amount of power of the wireless medical sensor; or any combination thereof.

5. The wireless medical sensor of claim 1, wherein the control circuitry is capable of sampling the physiological measurement to determine a sampled measurement and wherein the wireless transceiver circuitry is capable of communicating the sampled measurement through the wireless web to the external device.

6. The wireless medical sensor of claim 1, wherein the control circuitry is capable of determining whether the medical device is to serve as a main point of communication with the external device.

7. The wireless medical sensor of claim 6, wherein the control circuitry is capable of determining whether the medical device is to serve as the main point of communication based at least in part on a communication factor, wherein the communication factor comprises a proximity of the wireless medical sensor to the external device; a button press or switch setting on the wireless medical sensor; a remaining amount of power of the wireless medical sensor; an instruction from the external device; or a signal quality of the wireless transceiver circuitry; or any combination thereof.

8. The wireless medical sensor of claim 1, comprising an energy harvesting charging device capable of providing power to the wireless medical sensor.

9. The wireless medical sensor of claim 8, wherein the energy harvesting charging device is capable of piezoelectric energy harvesting; inductive energy harvesting; or thermoelectric energy harvesting; or any combination thereof.

10. The wireless medical sensor of claim 1, comprising a battery capable of providing power to the wireless medical sensor.

11. A method comprising:

activating a wireless medical sensor following a period of inactivity, the wireless medical sensor being attached to a patient and in communication with a wireless web comprising at least one other wireless medical sensor in communication with an external device, wherein the period of inactivity depends upon a status of the patient; obtaining a physiological measurement of the patient using the wireless medical sensor;

communicating the physiological measurement to the external device via the wireless web; and

deactivating the wireless medical sensor for the period of inactivity.

12. The method of claim 11, wherein the obtained physiological measurement comprises a photoplethysmographic measurement; a temperature measurement; a respiration measurement; a blood pressure measurement; an electrocardiogram measurement; an electroencephalogram measurement; or a pulse transit time measurement; or any combination thereof.

13. The method of claim 11, wherein communicating the physiological measurement to the external device via the wireless web comprises communicating with one of the at least one other wireless medical sensors using a protocol based on the IEEE 802.15.4 standard; the IEEE 802.11.x standards; or the Bluetooth standard; or any combination thereof.

14. The method of claim 13, wherein the protocol comprises ZigBee; WirelessHART; or MiWi; or any combination thereof.

15. A patient monitor comprising:

a wireless transceiver capable of receiving physiological measurements of a patient from a wireless web of medical sensors and transmitting to the wireless web of medical sensors instructions to the wireless web of medical sensors to operate at a data update rate level; and

data processing circuitry capable of determining the data update rate level based at least in part on a status of the patient.

16. The patient monitor of claim 15, wherein the wireless transceiver is capable of communicating using a protocol based on the IEEE 802.15.4 standard; the IEEE 802.11.x standards; the Bluetooth standard; or any combination thereof.

17. The patient monitor of claim 15, wherein the data processing circuitry is capable of determining the data update rate level based at least in part on a data update rate level factor associated with the status of patient, wherein the data update rate level factor comprises a value of one of the physiological measurements; a historical stability of the physiological measurements; a button press or switch setting on one of the medical sensors of the wireless web of medical sensors; a button press or switch setting on the patient monitor; a current location of the patient; a current location of a clinician; a movement of the patient; an initialization status of the wireless web of medical sensors; a data update rate level determined by one of the medical sensors of the wireless web of medical sensors; or a remaining amount of power of one of the medical sensors of the wireless web of medical sensors; or any combination thereof.

18. A system comprising:

two or more medical sensors capable of obtaining a physiological measurement of a patient and forming a wireless web, wherein the two or more medical sensors are configured to operate at a data update rate level based at least in part on a status of the patient; and

a patient monitor capable of communicating with the wireless web formed by the two or more medical sensors.

19. The system of claim 18, wherein the patient monitor is capable of communicating with the wireless web by communicating wirelessly with a main communication medical sensor of the two or more medical sensors.

**20.** The system of claim **18**, comprising a local transceiver capable of facilitating communication between the patient monitor and the wireless web by communicating wirelessly with the wireless web and by communicating by wire with the patient monitor.

**21.** The system of claim **18**, comprising a wired medical sensor capable of facilitating communication between the patient monitor and the wireless web by communicating wirelessly with the wireless web and by communicating by wire with the patient monitor.

**22.** The system of claim **18**, comprising a personal server capable of facilitating communication between the patient monitor and the wireless web by communicating wirelessly with the wireless web and the patient monitor.

**23.** The system of claim **22**, wherein the personal server is capable of communicating wirelessly with the wireless web using a first protocol and communicating wirelessly with the patient monitor using a second protocol.

**24.** The system of claim **18**, wherein at least one of the two or more medical sensors is capable of communicating with a portable phone.

**25.** The system of claim **18**, wherein the two or more medical sensors or the patient monitor, or a combination thereof, are capable of determining the data update rate level based at least in part on the status of the patient.

**26.** A method comprising:

providing a first wireless medical sensor capable of forming a wireless web with a second wireless medical sensor, wherein the first wireless medical sensor is configured to operate at a data update rate level based at least in part on a status of a patient; and

providing the second wireless medical sensor, wherein the second wireless medical sensor is capable of forming the wireless web with the first wireless medical sensors and wherein the second wireless medical sensor is configured to operate at the data update rate level.

\* \* \* \* \*

专利名称(译)	自适应无线体网		
公开(公告)号	<a href="#">US20110213216A1</a>	公开(公告)日	2011-09-01
申请号	US12/714532	申请日	2010-02-28
[标]申请(专利权)人(译)	内尔科尔普里坦贝内特公司		
申请(专利权)人(译)	NELLCOR PURITAN BENNETT LLC		
当前申请(专利权)人(译)	COVIDIEN LP		
[标]发明人	MCKENNA EDWARD M LISOGURSKI DANIEL		
发明人	MCKENNA, EDWARD M. LISOGURSKI, DANIEL		
IPC分类号	A61B5/00		
CPC分类号	A61B2560/0209 A61B5/0002 G06F1/3203 H04W52/02 Y02D70/10 Y02D70/14 Y02D70/142 Y02D70/144 Y02D70/162 Y02D70/22		
其他公开文献	US10206570		
外部链接	<a href="#">Espacenet</a> <a href="#">USPTO</a>		

摘要(译)

提供了用于使用自适应身体网络获得患者的生理测量的系统，方法和设备。在一个示例中，无线医疗传感器可以包括生理传感器电路，无线收发器电路和控制电路。生理传感器电路可以能够获得患者的生理测量。无线收发器电路可以能够加入包括至少一个其他无线医疗传感器的无线网络，无线收发器电路可以通过该无线网络将生理测量传送到外部设备。控制电路可以能够至少部分地基于患者的状态来确定操作生理传感器或无线收发器电路或其组合的数据更新速率。

