



(19) **United States**

(12) **Patent Application Publication**
Ochs et al.

(10) **Pub. No.: US 2010/0063366 A1**
(43) **Pub. Date: Mar. 11, 2010**

(54) **SYSTEM AND METHOD FOR DETECTING VENTILATORY INSTABILITY**

Publication Classification

(76) Inventors: **James Ochs**, Seattle, WA (US);
Keith Batchelder, New York, NY (US);
Yu-Jung Pinto, Boulder, CO (US)

(51) **Int. Cl.**
A61B 5/00 (2006.01)
(52) **U.S. Cl.** **600/301**
(57) **ABSTRACT**

Correspondence Address:
Nellcor Puritan Bennett LLC
60 Middletown Avenue
North Haven, CT 06473 (US)

Embodiments described herein may include systems and methods for detecting events that may be associated with sleep apnea. Some embodiments are directed to a system and/or method for automated detection of reduction in airflow events using polysomnograph signals, wherein the reduction in airflow events may relate to sleep apnea. The PSG signals may be limited to four signals, including data from an airflow channel, a blood oxygen saturation channel, a chest movement channel, and an abdomen movement channel. Using information from these channels, some embodiments may automatically identify reduction in airflow events.

(21) Appl. No.: **12/208,087**

(22) Filed: **Sep. 10, 2008**

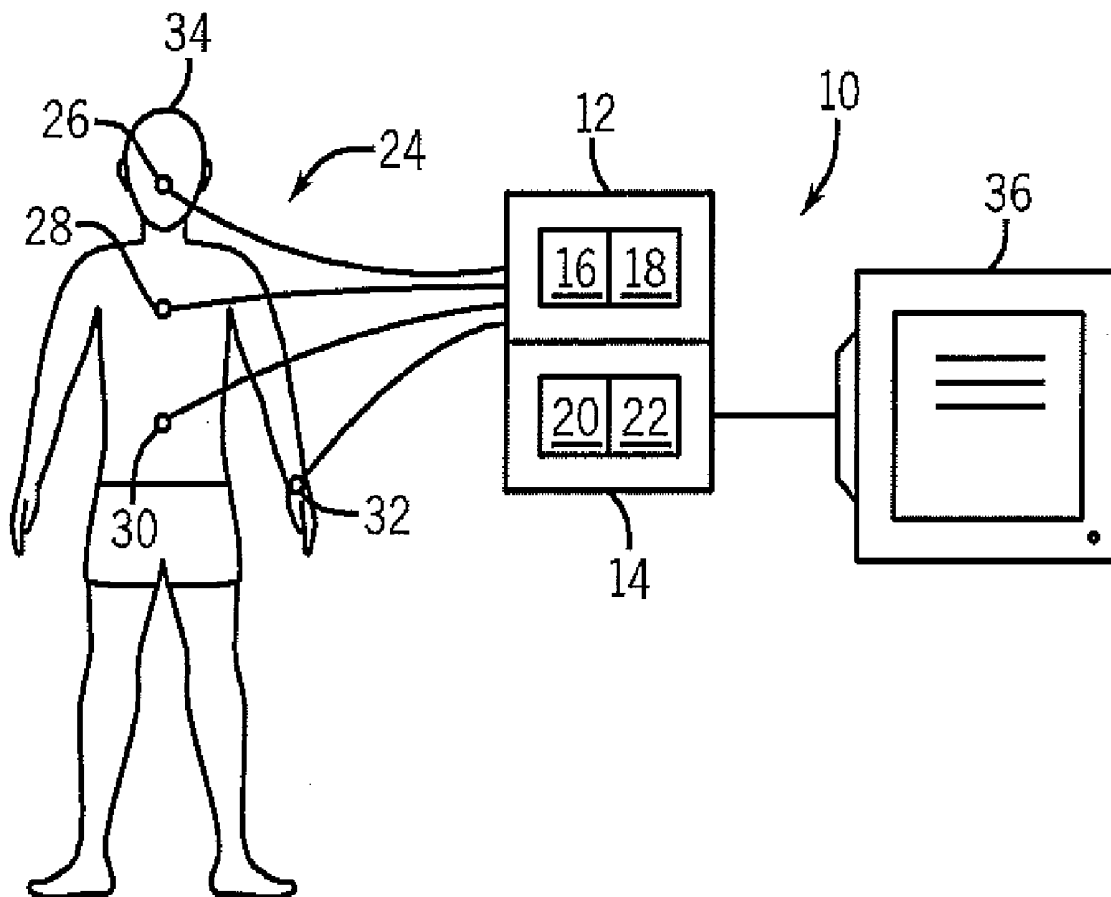

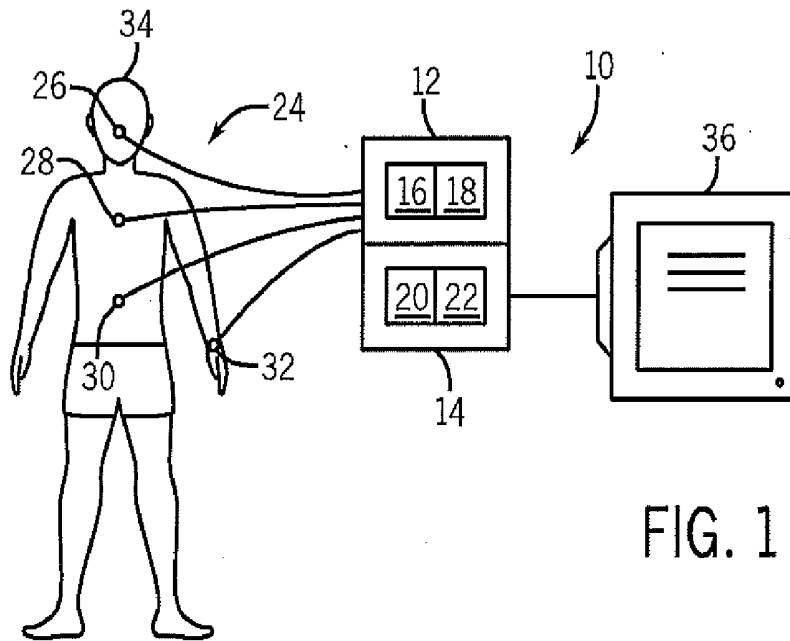

FIG. 1

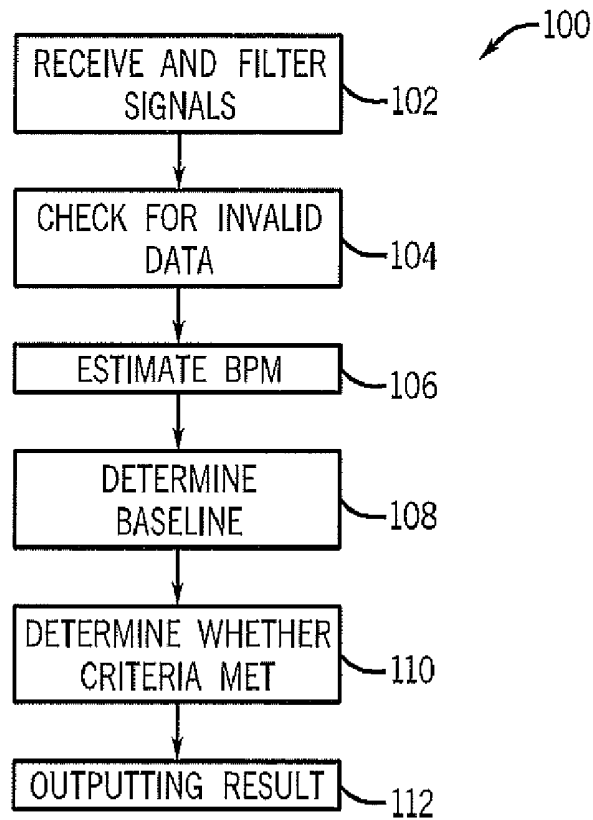
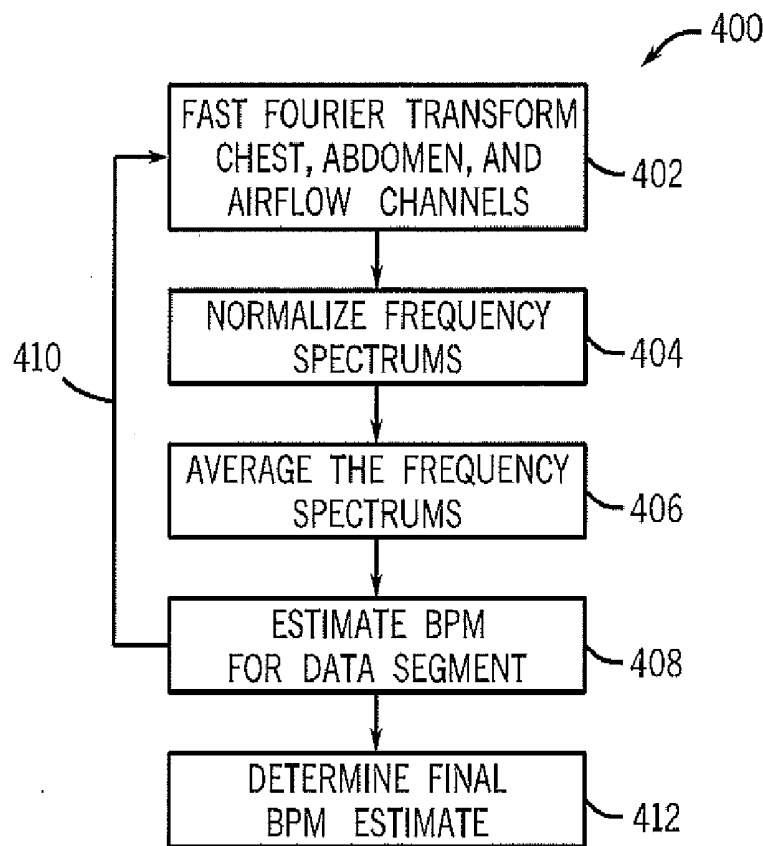
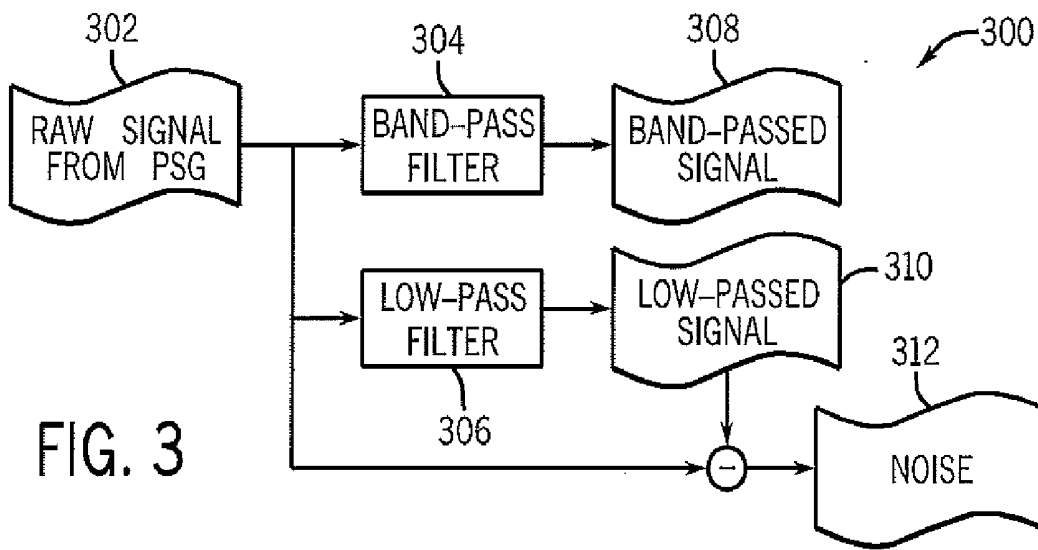

FIG. 2



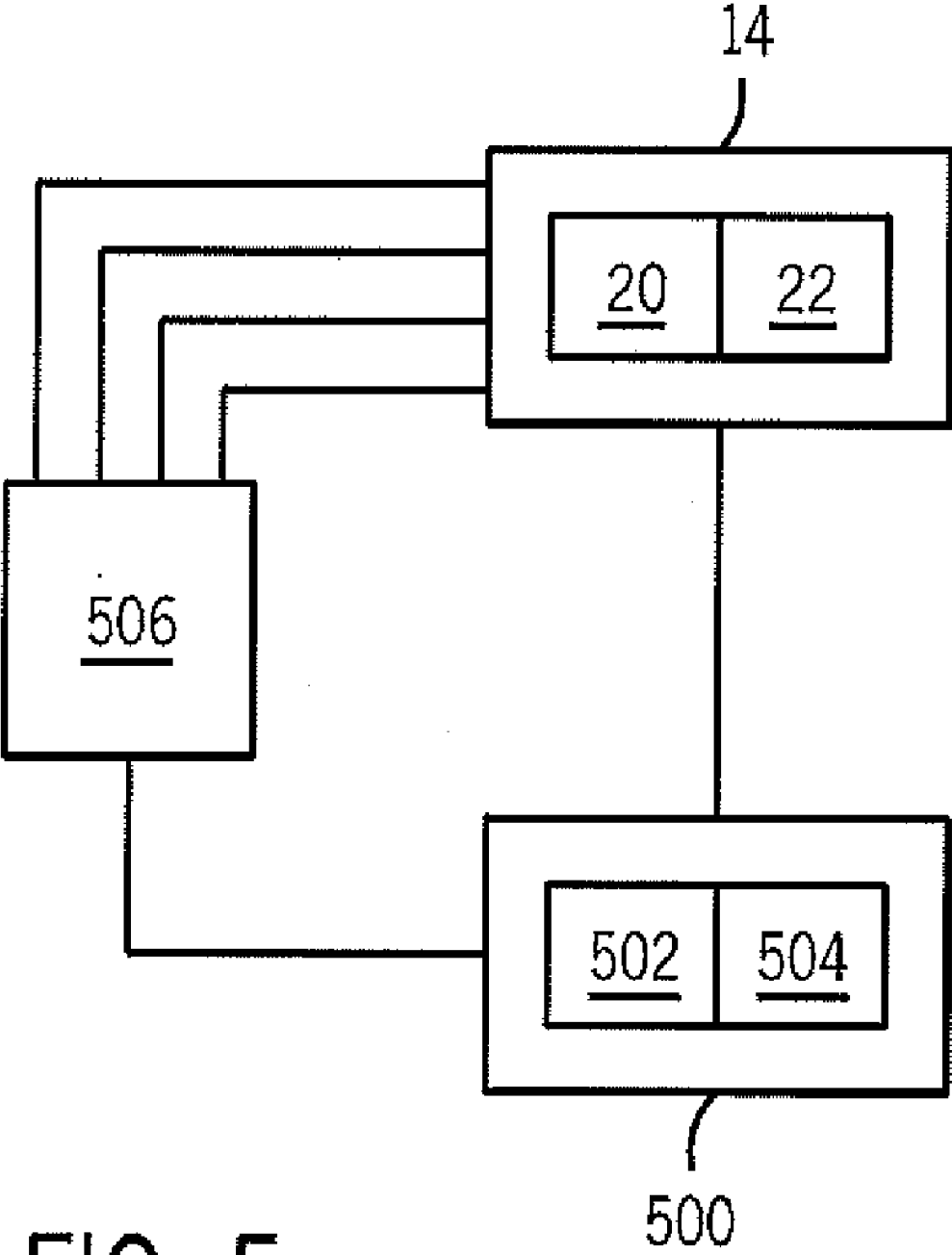

FIG. 5

SYSTEM AND METHOD FOR DETECTING VENTILATORY INSTABILITY

BACKGROUND

[0001] The present disclosure relates generally to medical devices and methods and, more particularly, to an automated system and method for detecting events related to ventilatory instability, such as sleep apnea.

[0002] This section is intended to introduce the reader to various aspects of art that may be related to various aspects of the present disclosure, which are described and/or claimed below. This discussion is believed to be helpful in providing the reader with background information to facilitate a better understanding of the various aspects of the present disclosure. Accordingly, it should be understood that these statements are to be read in this light, and not as admissions of prior art.

[0003] Sleep apnea is generally described as a sleep disorder that is characterized by episodes of paused breathing during sleep. These episodes of paused breathing may occur repeatedly throughout sleep, and each episode may last long enough to cause one or more breaths to be missed. Such episodes may be referred to as apneas. A typical definition of an apnea may include an interval between breaths of at least 10 seconds, with a neurological arousal and/or a blood oxygen desaturation of 3% or greater. The actual duration and severity of each apnea may substantially vary between multiple patients. Further, duration and severity of apneas may vary throughout a period of sleep for a single patient. Indeed, sleep apnea may have a wide range of severity. For example, sleep apnea may include mild snoring, which may be related to incomplete and inconsequential airway obstruction, or severe apneas, which may result in hypoxemia. Sleep apnea commonly results in excessive daytime sleepiness. Further, sleep apnea can hinder cognitive function during the day due to sporadic sleep during the night resulting from recurrent arousals associated with the sleep apnea.

[0004] Although sleep apnea commonly affects obese patients, it may occur in patients with any body type. Indeed, sleep apnea is fairly common and causes undesirable symptoms of excessive daytime sleepiness, morning headache, and decreasing ability to concentrate during the day. Thus, it is desirable to diagnose and treat sleep apnea. Traditionally, sleep apnea is diagnosed utilizing an overnight sleep test referred to as a polysomnogram. This is generally performed in a sleep lab and involves the continuous and simultaneous measurement and recording of an encephalogram, electromyogram, extraoculogram, chest wall plethysmogram, electrocardiogram, measurements of nasal and oral airflow, and pulse oximetry. All or some of these and other channels may be measured simultaneously throughout the night, and complex recordings of such measurement may then analyzed by a highly trained clinician to determine the presence or absence of sleep apnea.

BRIEF DESCRIPTION OF THE DRAWINGS

[0005] Advantages of the disclosure may become apparent upon reading the following detailed description and upon reference to the drawings in which:

[0006] FIG. 1 is a block diagram of a medical analysis system in accordance with some embodiments;

[0007] FIG. 2 is a process flow diagram of a method for detecting ventilatory instability related events in accordance with some embodiments;

[0008] FIG. 3 is a block diagram of a device and/or module capable of receiving and filtering signals in accordance with some embodiments;

[0009] FIG. 4 is a process flow diagram of a method for estimating a value for breathes per minute of a patient in accordance with some embodiments; and

[0010] FIG. 5 is a block diagram of the system of FIG. 1 communicatively coupled with a separate ventilatory instability detection system to facilitate calibration of the separate system in accordance with some embodiments.

DETAILED DESCRIPTION

[0011] One or more embodiments of the present disclosure will be described below. In an effort to provide a concise description of the embodiments, not all features of an actual implementation are described in the specification. It should be appreciated that in the development of any such actual implementation, as in any engineering or design project, numerous implementation-specific decisions may be made to achieve the developers' specific goals, such as compliance with system-related and business-related constraints, which may vary from one implementation to another. Moreover, it should be appreciated that such a development effort might be complex and time consuming, but would nevertheless be a routine undertaking of design, fabrication, and manufacture for those of ordinary skill having the benefit of this disclosure.

[0012] Some embodiments are directed to automated systems and methods for detecting events that may be associated with sleep apnea. Specifically, some embodiments are directed to a system and/or method for automated detection of reduction in airflow events using polysomnograph (PSG) signals, wherein the reduction in airflow events may relate to sleep apnea. The PSG signals may be limited to four signals, including data from an airflow channel, a blood oxygen saturation (SpO₂) channel, a chest movement channel, and an abdomen movement channel. Using information from these channels, some embodiments may automatically identify reduction in airflow events.

[0013] Accordingly, some embodiments may facilitate automated detection and/or diagnosis of sleep apnea in patients. For example, some embodiments may be utilized to analyze data that has been acquired using a separate PSG system to determine whether sleep apnea related events have occurred. In another example, some embodiments may be incorporated with a PSG system to automatically detect and/or diagnose sleep apnea while a patient is being monitored. Indeed, some embodiments may facilitate detection of events relating to sleep apnea and/or facilitate diagnosis of sleep apnea in real time. Further, some embodiments may be utilized to demonstrate or confirm the accuracy or reliability of other systems and/or methods for detecting events related to sleep apnea. For example, some embodiments may be utilized in conjunction with a device configured to identify ventilatory instability (e.g., sleep apnea) based on an SpO₂ pattern recognition algorithm.

[0014] In some embodiments, a distinction may be made between whether identified sleep apnea events correspond to central sleep apnea or obstructive sleep apnea. Central and obstructive sleep apnea may be distinguished based on the nature of their occurrence. For example, a lack of effort in breathing is generally the cause of interrupted breathing associated with central sleep apnea, while a physical block in airflow despite effort is generally the cause of interrupted breathing associated with obstructive sleep apnea. If a patient

is or is not making an effort to breathe, the patient's chest and abdomen activity may be indicative. Accordingly, some embodiments may distinguish between the two types of apnea by including devices or modules that are capable of quantifying phase differences between chest and abdomen signals. For example, some embodiments may include an algorithm stored on a memory that receives chest and abdomen signals and determines that certain events correspond to obstructive sleep apnea when the chest and abdomen signals are out of phase, or that the events correspond to central sleep apnea when there is no chest and/or abdomen movement, or there is a decrease in chest and abdomen movement but signals are in phase.

[0015] FIG. 1 is a block diagram of a medical analysis system in accordance with some embodiments. The medical analysis system is generally indicated by reference numeral 10. The system 10 includes a PSG system 12 and an event detection (ED) system 14. The PSG system 12 and the ED system 14 may be separate or integrated in accordance with some embodiments. The PSG system 12 may include, for example, hardware and/or software products from Nellcor Puritan Bennett's Sandman® sleep diagnostics line of products.

[0016] According to an embodiment, the PSG system 12 may include a memory 16 and a processor 18, and the ED system 14 may include a memory 20 and a processor 22. Programming stored on the respective memories 16 and 20 for the PSG system 12 and the ED system 14 may be utilized in conjunction with each system's respective processor 18 and 22 to facilitate performance of certain functions by the PSG system 12 and the ED system 14. For example, the memories 16 and 20 may include coded instructions that may be utilized with the respective processors 18 and 22 to perform automated methods in accordance with some embodiments. It should be noted that, in some embodiments, the memories 16 and 20 may be integral with the respective processors 18 and 22. Further, if the PSG system 12 and ED system 14 are integral components of the system 10, the integrated PSG system 12 and ED system 14 may share a single memory and/or a single processor.

[0017] According to an embodiment, the PSG system 12 may be capable of receiving signals from various sensors 24 that are capable of measuring certain physiologic parameters or patient activities. Specifically, the sensors 24 may include an airflow sensor 26, a chest sensor 28, an abdomen sensor 30, and a pulse oximeter sensor 32. Each of the sensors 24 may be attached to a patient 34 to facilitate measuring physiologic parameters and/or physical activity (e.g., movement) of the patient 34. These four measured values from the sensors 24 may be transmitted as signals to the PSG system 12 for processing. Thus, the sensors 24 may cooperate with the PSG system 12 to provide a polysomnogram. A polysomnogram may be described as a recording of an individual's sleep characteristics (e.g., activities and physiological events occurring during sleep), which may include an output of various measurements obtained by the sensors 24. Such an output may be recorded on a memory (e.g., a flash memory or hard drive), presented on other tangible medium (e.g., printed on paper), or visually displayed (e.g., displayed as video). For example, the polysomnogram, along with other data, may be displayed on a video screen 36 of the medical analysis system 10.

[0018] According to an embodiment, the ED system 14 may be capable of using data acquired by the PSG system 12,

such as the polysomnogram, to automatically detect events that may be associated with sleep apnea. For example, the ED system 14 may automatically detect reduction in airflow events, which relate to sleep apnea, using four PSG signals from the PSG system 12. The PSG signals may be transferred to the ED system 14 from the PSG system 14 in a number of ways. For example, data corresponding to signals from the PSG system 12 may be manually entered into the ED system 14, transferred via a memory device (e.g., a flash memory), or directly transmitted to the ED system 14 from the PSG system 12 for analysis. The PSG system 12 and the ED system 14 may receive and/or transmit signals corresponding to particular signal types based on data in a memory (e.g., a flash memory or a memory of the PSG system 12) and/or directly from each of the sensors 24. The PSG signals and/or signal data may be referred to as channels corresponding to each signal, such as airflow, chest, abdomen, and pulse oximetry channels.

[0019] According to an embodiment, once the ED system 14 receives the PSG signals, which may be in the form of signal data, the ED system 14 may perform an automated process on the PSG signals to identify events related to sleep apnea, such as reduction in airflow events. If certain events are identified in accordance with specified rules or criteria, the ED system 14 may provide an indication of the presence of ventilatory instability. For example, the ED system 14 may include hardware and/or software components that filter one or more of the PSG signals and identify characteristics of the signals that combine to suggest the presence of events related to sleep apnea. Specifically, for example, after checking for invalid data, filtered and unfiltered PSG signals may be utilized by the ED system 14 to estimate a value of breathes per minute (BPM) of the patient 34. The estimated BPM may then be utilized by the ED system 14 to calculate a baseline for use in determining whether a threshold level of airflow reduction is present. Further, the ED system 14 may determine whether certain other events indicative of respiratory instability are present based on the PSG signals, as will be discussed in further detail below. The ED system 14 may output values indicative of whether respiratory instability is present based on whether certain events were identified. For example, the ED system 14 may indicate the presence of sleep apnea and/or indicate a type of sleep apnea (e.g., central or obstructive) based on results obtained through analysis of a neural network of the ED system 14. It should be noted that the identification of events by the ED system 14 may be facilitated by an algorithm stored in the memory 20, which may cooperate with the processor 22 to implement methods in accordance with some embodiments. It should further be noted that the algorithm may be tuned by adjusting constant values in the algorithm to correspond to particular situations or patients (e.g., a patient with a heart condition).

[0020] FIG. 2 is a process flow diagram illustrating a method in accordance with some embodiments. The method is generally indicated by reference number 100 and includes various steps or actions represented by blocks. It should be noted that the method 100 may be performed as an automated procedure by a system, such as the analysis system 10. Further, certain steps or portions of the method may be performed by separate devices. For example, a first portion of the method 100 may be performed by the PSG system 12 and a second portion of the method 100 may be performed by the ED system 14. In this embodiment, the method includes receiving and filtering signals (block 102), checking for invalid data

(block 104), estimating BPM (block 106), determining a signal baseline for certain signals (block 108), determining whether certain criteria are met by acquired data (block 110), and outputting a result (block 112).

[0021] According to an embodiment, the method 100 begins with receiving and filtering signals, which may include signal data, as represented by block 102. Block 102 may include receiving and/or filtering signal data from several sensors, which may include the airflow sensor 26, the chest sensor 28, the abdomen sensor 30, and/or the pulse oximeter sensor 32. Specifically, block 102 may represent receiving data or signals from airflow, chest, abdomen, and pulse oximetry channels and filtering signals on a subset of the channels. Signals on the chest, airflow, and abdomen channels may be filtered, while signals on the pulse oximetry channel, which may relate to SpO₂ data, may remain unfiltered. For example, FIG. 3 illustrates a component 300 capable of filtering the chest, airflow, and abdomen channels in accordance with some embodiments. In some embodiments, the component 300 may be a feature of the processor, or it may be implemented using electronic circuits which preprocess and filter some or all of the PSG signals. 22. Specifically, as illustrated in FIG. 3, a raw signal 302 from the PSG system 12, such as a signal on the chest, airflow or abdomen channel, may be received into the component 300 of the ED system 114. The raw signal 302 may pass through the component 300, which may include passing the raw signal through a band-pass filter 304 and a low-pass filter 366 of the component 300.

[0022] According to an embodiment, the band-pass filter 304 may pass frequencies within a selected range and attenuate frequencies that are outside of the selected range. Specifically, for example, the band-pass filter 30 may include a 0.0833-1 Hz band-pass filter that operates to pass frequencies corresponding to 5-60 BPM and filter out frequencies above and below that range. An initial or default 5-60 BPM pass band may be used since most human breathing rates will be within this range under typical sleep-lab conditions. The pass band may be tuned (moved, narrowed, and/or widened) by the operator based on known patient conditions to increase the specificity and/or sensitivity of the ED system. Once the raw signal 302 has passed through the band-pass filter 304, it becomes a band-passed signal 308. The band-passed signal 308 may be utilized in conjunction with other input in the analysis and identification of ventilatory instability, as will be discussed in further detail below.

[0023] According to an embodiment, the low-pass filter 306 may pass frequencies below a cutoff level and attenuate frequencies higher than the cutoff level. Specifically, for example, the low-pass filter 306 may attenuate frequencies lower than 0.04166 Hz, which corresponds to 2.5 BPM. 2.5 BPM may be selected as the initial cutoff level since it is unlikely that any patient will breathe slower than this rate, and therefore frequencies below this level can be considered noise, or more specifically these frequencies can be considered the DC offset of the PSG signal. The operator may move the low pass filter level based on known patient conditions in an attempt to increase the specificity and sensitivity of the ED system. Once the raw signal 302 has passed through the low-pass filter 306, it becomes a low-passed signal 310. The low-passed signal 310 may be used to calculate a noise signal 312 by passing it through a subtraction block 314 with the raw signal 302 to get a difference between the raw signal 302 and the low-passed signal 310. This and other features of

noise calculation will be discussed in further detail below. The calculated noise level may be utilized to clarify signal features by reducing noise content. In some embodiments, features may be included that facilitate reading data through the noise, rather than merely removing the noise (I put a more specific example at the end of the next paragraph, maybe remove the last sentence in this paragraph, or keep both).

[0024] According to an embodiment, after the signals have been received and/or filtered in block 102, the method 100 may proceed to block 104, which includes checking for invalid data. Specifically, block 104 may represent receiving and processing a stream of data to determine whether any portions of the data meet criteria indicating that the data should be discarded. For example, block 104 may represent receiving a 10 minute segment of data that is analyzed to determine if the following criteria are present: (1) the SpO₂ signal is less than a designated value (e.g., less than a value of 20% SpO₂, which may indicate that the sensor is off or disconnected), (2) the signal to noise ratio for a signal on the airflow channel is less than a designated value (e.g., 5 dB), (3) the signal to noise ratio for a signal on the chest channel is less than a designated value (e.g., 0 dB), and/or (4) a signal to noise ratio (SNR) for a signal on the abdomen channel is less than a designated value (e.g., 0 dB). If it is determined in block 104 that any of the designated criteria, such as the criteria set forth above, are present for a designated period, e.g., 2 minutes, within the 10 minute segment of data, all or part of the 10 minute segment of data may be discarded as being invalid. In some embodiments, features may be included that facilitate reading through data with a SNR below a threshold, rather than merely invalidating data because of low SNR values.

[0025] It should be noted that the signal to noise ratios referenced above may be automatically calculated in block 104 along with other determinations relating to identifying invalid data. For example, block 104 may represent calculating the signal to noise ratio for a particular signal by first removing DC from the raw signal 302. That is, the low-passed signal 310 (LPFilteredSignal) may be subtracted from the raw signal 302 (RawSignal) to obtain a raw signal without DC (RawSignalNoDC). This procedure may be represented by the following equation:

$$\text{RawSignalNoDC} = \text{RawSignal} - \text{LPFilteredSignal}.$$

[0026] Noise may then be calculated by subtracting the band-passed signal 308 (BPSignal) from the raw signal without DC. This procedure may be represented by the following equation:

$$\text{Noise} = \text{RawSignalNoDC} - \text{BPSignal}.$$

[0027] A statistical measure of magnitude, such as a root mean square, may then be obtained for both the noise and the band-passed signal, and the signal to noise ratio (SNR) may be calculated by dividing the root mean square of the band-passed signal (RMS(Signal)) by the root mean square of the noise (RMS(Noise)), as represented by the following equation:

$$\text{SNR} = \text{RMS}(\text{Signal}) / \text{RMS}(\text{Noise}).$$

As will be appreciated, in some embodiments, different calculations or procedures may be utilized to obtain the signal to noise ratio.

[0028] According to an embodiment, after invalid data has been removed in block 104, the method 100 may proceed to determine an estimated BPM based on the received data, as

represented by block 106. As illustrated in FIG. 4, the BPM estimate may be calculated using the chest, abdomen, and airflow signals. FIG. 4 is a process flow diagram of a method of estimating BPM in accordance with some embodiments. The method of estimating BPM is generally indicated by reference number 400 and includes various steps or actions represented by blocks. As with the other steps of the method 100, the method 400 may be performed as an automated procedure by the system 100 in accordance with some embodiments.

[0029] According to an embodiment, the method 400 begins by receiving band-passed airflow, chest, and abdomen signals, and converting the signals to the frequency domain by performing a fast Fourier transform (FFT) on all three channels, as represented by block 402. Specifically, block 402 may represent determining an FFT for the three channels a certain number of times per time period. For example, block 402 may represent calculating an FFT for the band-passed airflow, chest, and abdomen signals once every 2 minutes.

[0030] According to an embodiment, after performing the frequency conversion in block 402, the method 400 may proceed to block 404, which represents normalizing the frequency spectrums obtained in block 402. The procedure represented by block 404 may include various different types of normalization, which may result in ranging the frequency spectrums from 0.0 to 1.0. For example, peak normalization may be performed by dividing the amplitude at each point in the spectrum of each signal by the maximum amplitude of that particular spectrum. Thus, the normalized spectrum may include intensities that range from as low as 0.0 to as high as 1.0. By normalizing the spectrums, certain discrepancies between the spectrums may be removed to facilitate proper combination or comparison of the different spectrums. It should be noted that each spectrum may be based on a segment of data, such as a 10 minute segment of recorded sensor data.

[0031] According to an embodiment, after the spectrums have been normalized in block 404, all three frequency spectrums may be averaged, as represented by block 406, and an estimate of BPM may be calculated based on the average, as represented by block 408. Specifically, blocks 406 and 408 may include averaging all of the histograms of the frequency spectrums and selecting a frequency from the average that has the highest amount of energy to determine the estimate BPM for the associated segment of data. This procedure may be represented by the following equation:

$$\text{BPM Estimate} = \max(\text{Average Frequency Spectrum}).$$

[0032] According to an embodiment, the process of providing BPM estimates for a segment of data may be repeated for a series of data segments, as represented by arrow 410. The most recent BPM estimate obtained for a data segment may be referred to as the current estimate and the penultimate BPM estimate obtained for a previous data segment may be referred to as the previous estimate. In other words, once a new segment of data has been received and processed, the BPM estimate that was the current estimate may become the previous segment and the BPM estimate for the most recent segment of data may become the current estimate. As represented by block 412, the current and previous estimates may be averaged to provide a final BPM estimate, as represented by the following equation:

$$\text{Final BPM Estimate} = 0.5(\text{Current Estimate} + \text{Previous Estimate}).$$

It should be noted that in some embodiments, more than two estimates may be averaged to determine the final BPM estimate. For example, three or more estimates for a series of data segments may be stored and averaged to determine a final BPM estimate in accordance with some embodiments.

[0033] According to an embodiment, after estimating BPM in block 106, the method 100 may proceed to determining a signal baseline for each signal, as represented by block 108. Specifically, for example, block 108 may include calculating a signal baseline for the airflow, chest, and abdomen signals. In performing this calculation, a root mean square value for the signal (e.g., the raw signal 302) may first be obtained using the final BPM estimate and a running root mean square, as indicated by the following equation:

$$X_{\text{rms}} = 0.5 \text{ BPM running RMS signal } X.$$

This calculation may take into account every point of a signal such that the results are indicative of the power of the signal at each point. The baseline value (X-Baseline) for each particular signal may then be determined based on this root mean square value (X_{rms}). Specifically, the baseline may be determined as the top 10% or ninetieth percentile of the root mean square value, as represented by the following equation:

$$X\text{-Baseline} = \text{Top } 10\% \text{ (90th percentile) of } X_{\text{rms}}.$$

[0034] According to an embodiment, once a baseline has been determined for the airflow, chest, and abdomen signals, as represented by block 108, the method 100 may proceed with determining whether certain criteria are met, as represented by block 110. The presence of characteristics that meet certain criteria may indicate and confirm that a reduction in airflow (RAF) event occurred relative to a normal airflow. For example, a determination may be made as to whether a certain level of reduction (e.g., a 40% reduction) in airflow has occurred for at least a threshold amount of time (e.g., 10 seconds). This may be referred to as an RAF event. Specifically, in one embodiment, an RAF event may be described as an interval where the amplitude envelope of a signal on the airflow channel from the PSG system 12 is reduced at least 40% relative to the baseline for at least 10 seconds consecutively. It should be noted that the amplitude envelope may refer to the value of a function describing how the maximum amplitude of the airflow signal changes over time.

[0035] According to an embodiment, once an RAF event has been identified, it may be qualified for consideration based on certain scoring rules. For example, an RAF event may be disqualified if there is not a specified amount of change in one or more other signal measurements within a certain window of time with respect to the time the RAF event occurred. For example, if the measured SpO_2 value does not change at least a certain amount, e.g., 3%, during the RAF event or within a certain time, e.g., 30 seconds, after the RAF event, the RAF event may be disqualified. Similarly, for example, if there is not at least a certain change, e.g., a 40% reduction, in the chest or abdomen signal from the PSG system 12 for at least part, e.g., half, of the interval of the RAF event, the RAF event may be disqualified. Alternatively, if the available data meets these criteria, the RAF event may be qualified and used to determine whether the data is indicative of ventilatory instability in the patient that was or is being monitored.

[0036] According to an embodiment, block 110 may also represent determining whether a segment of data includes an indication of ventilatory instability based on a quantity of qualified RAF events that occur within the data segment. For

example, block **110** may determine that a particular data segment is indicative of ventilatory instability if a certain number, e.g., at least 5, of consecutive RAF events are qualified within a given portion, e.g., a 10 minute period, of the segment of data. Thus, segments of data may be divided into intervals, e.g., 10 minute intervals, in accordance with some embodiments. It should be noted that in order for the RAF events to be qualified as being consecutive, certain relative timing criteria may have to be met. For example, in one embodiment, for a pair of qualified RAF events to be consecutive, the RAF events must occur within a certain time, e.g., 120 seconds, of one another.

[0037] According to an embodiment, block **110** may also represent determining a type of respiratory event, such as determining the presence of central or obstructive sleep apnea based on correlations between different signals, such as the chest and abdomen signals being in or out of phase. As discussed above, central and obstructive sleep apnea may be distinguished based on the nature of their occurrence. For example, a lack of effort in breathing is generally associated with central sleep apnea, while a physical block in airflow despite effort is generally associated with obstructive sleep apnea. A patient's chest and abdomen activity may be utilized to distinguish between the two types of apnea. Accordingly, some embodiments may include features that are capable of quantifying phase differences between chest and abdomen signals. For example, some embodiments may include features that determine that certain events correspond to obstructive sleep apnea when the chest and abdomen signals are out of phase, or that the events correspond to central sleep apnea when there is no chest and/or abdomen movement, or there is a decrease in chest and abdomen movement but signals are in phase.

[0038] Based on the criteria or rules discussed above, the method **100** may output an epoch score for each data segment, as represented by block **112**. For example, an epoch score may be repeated once every time a segment of data has been analyzed (e.g., once every 10 minutes). In some embodiments, a system may utilize such a score in an algorithm to provide an indication of certain conditions relating to ventilatory instability. For example, the epoch score may include a value of 1 for an indication that sleep apnea has been detected, 0 for an indication that sleep apnea has not been detected, or -1 for an indication of invalid data. The indicator provided by the system based on the score may include a textual indication of the detected condition, such as "sleep apnea detected," "sleep apnea not detected", or "unknown or invalid data." In some embodiments, a series of epoch scores may be combined for all or part of a sleep study to generate an aggregate score. For example, an average of all of the scores for each 10 minute segment of a sleep cycle may be used to determine a summary score for a particular patient.

[0039] Further, in some embodiments, the severity of the ventilatory instability or apnea events may be quantified instead of merely providing binary outputs. For example, the depth of the airflow reduction may be used to quantify a severity of the ventilatory instability. In some embodiments different aspects associated with qualified RAF events may be used to determine levels of severity. For example, a series of continually larger drops in airflow and/or continual failures to return to a baseline level of airflow may be correlated to a higher level of severity. Further, numerous clusters of RAF events or data segments including RAF events may be considered in determining a severity level. For example, a large

segment of data, e.g., 4 hours of data, may include various sub-segments having different levels of apnea. Each sub-segment may be analyzed separately based on certain criteria, such as a number of RAF events per time period, an amount of reduced airflow, or other characteristics, and the values associated with the sub-segments may be combined to provide an overall ventilatory instability level for the large segment of data.

[0040] The ED system **14** may be utilized to demonstrate or confirm that other systems involving detection of ventilatory instability related events are properly calibrated and/or providing results that correlate to the results obtained by the ED system **14**. For example, FIG. **5** is a block diagram of the ED system **14** communicatively coupled with a separate ventilation analysis system **500** to facilitate calibration of the system **500** or to confirm its proper operation. The separate ventilation analysis system **500** may include a system such as that described in U.S. Pat. No. 6,223,064. For example, the system **500** may include an SpO₂ pattern recognition system that is utilized to identify ventilatory instability based on a series of SpO₂ values. The system **500** may include a memory **502** and a processor **504** that are capable of analyzing input received or previously acquired from a single SpO₂ sensor. Specifically, the system **500** may be capable of identifying certain patterns or clusters of measured SpO₂ values to identify events related to ventilatory instability.

[0041] According to an embodiment, the ED system **14** may facilitate adjustment and/or calibration of the system **500** to correlate with BPM estimates determined by the ED system **14**. For example, both systems **14** and **500** may be provided with data from a storage device **506**, wherein the data corresponds to certain ventilatory instability events that have been observed. During a calibration period, the system **500** may be adjusted to correspond to the ED system **14**. In other words, the system **500** may be adjusted such that it detects a high percentage of the ventilatory instability events detected by the ED system **14**. For example, certain coefficients of an algorithm stored on the memory of the system **500** may be adjusted to improve correlations between the results for the system **500** and the results for the ED system **14**.

[0042] In a specific example, the ED system **14** may utilize automated analysis of the data obtained via the various sensors **24** to confirm that the system **500** is properly tuned and/or providing corresponding output. Specifically, the ED system **14** may receive data from the storage device **506** corresponding to airflow, chest impedance, abdomen impedance, and blood oxygen saturation, and use this data to provide results that include a BPM estimate. These results may be compared with similar results obtained by the system **500** using SpO₂ pattern recognition. Based on the comparison, certain features of the system **500** (e.g., features of a pattern recognition algorithm stored on the memory **502**) may be adjusted to achieve a desired correspondence. The automated analysis provided by the ED system **14** may facilitate rapid adjustment and/or testing of systems such as the system **500**.

[0043] Specific embodiments have been shown by way of example in the drawings and have been described in detail herein. However, it should be understood that the claims are not intended to be limited to the particular forms disclosed. Rather, the claims are to cover all modifications, equivalents, and alternatives falling within their spirit and scope.

What is claimed is:

1. A method for automated detection of ventilatory instability, comprising:

calculating an output value of breathes per minute for a data segment based at least in part upon signals of an airflow channel, a chest channel, and/or an abdomen channel and/or combinations thereof;

determining a baseline value for each of the airflow channel, the chest channel, and the abdomen channel based at least in part upon the output value of breathes per minute and/or a measure of the magnitude of the corresponding signals;

determining whether a reduction in airflow above a minimum reduction level relative to the baseline value for the airflow channel has been maintained for a period of time, and identifying a reduction in airflow event if the reduction in airflow is above the minimum reduction level; and

providing an indication of ventilatory instability if the reduction in airflow event is identified and meets a set of criteria.

2. The method of claim 1, further comprising converting the signals of the airflow channel, the chest channel, and/or the abdomen channel to a frequency domain to determine a plurality of frequency spectrums, wherein the plurality of frequency spectrums comprises an airflow channel frequency spectrum, a chest channel frequency spectrum, and/or an abdomen channel frequency spectrum.

3. The method of claim 2, wherein calculating the output value of breathes per minute comprises determining a highest frequency of an average of the plurality of frequency spectrums.

4. The method of claim 1, wherein calculating the output value of breathes per minute comprises averaging an estimate of breathes per minute for each of a plurality of data segments based at least in part upon the signals of the airflow channel, the chest channel, and/or the abdomen channel and/or combinations thereof.

5. The method of claim 1, further comprising determining whether a criterion is met that requires a pulse oximetry channel to change by a defined percentage within a window of time generally relative to the reduction in airflow event.

6. The method of claim 5, further comprising determining whether the pulse oximetry channel has changed by at least 3% relative to its baseline within 30 second of the reduction in airflow event to determine if the criterion is met.

7. The method of claim 1, further comprising determining whether a criterion is met that requires a reduction in the chest channel and/or the abdomen channel relative to the respective baseline values for a defined portion of the reduction in airflow event.

8. The method of claim 7, further comprising determining whether there was at least a 40% reduction relative to the respective baseline values in the chest channel and/or the abdomen channel for at least half of the reduction in airflow event to determine if the criterion is met.

9. The method of claim 1, further comprising discarding invalid data corresponding to the airflow channel, the pulse oximetry channel, the chest channel, and the abdomen channel based on whether certain indicators are present in an associated data segment.

10. The method of claim 1, wherein the data segment comprises a 10 minute data segment.

11. The method of claim 1, wherein the minimum reduction level relative to the baseline value for the airflow channel comprises a 40% reduction relative to the baseline value for the airflow channel.

12. The method of claim 1, comprising determining whether the reduction in airflow above the minimum reduction level relative to the baseline value for the airflow channel has been maintained for 10 seconds or more.

13. A system, comprising:

a processing device capable of calculating an output value of breathes per minute for a data segment based on signals of an airflow channel, a chest channel, and/or an abdomen channel and/or combinations thereof at least in part by determining a baseline value for each of the airflow channel, the chest channel, and/or the abdomen channel based at least in part upon the output value of breathes per minute and a measure of the magnitude of the corresponding signals; determining whether a reduction in airflow above a minimum reduction level relative to the baseline value for the airflow channel has been maintained for a period of time and identifying a reduction in airflow event if the reduction in airflow is above the minimum reduction level; and providing an indication of ventilatory instability if the reduction in airflow event is identified and meets a set of criteria.

14. The system of claim 13, comprising a filter capable of filtering the airflow channel, the chest channel, and/or the abdomen channel.

15. The system of claim 14, comprising a filter capable of band-pass filtering and low-pass filtering the airflow channel, the chest channel, and the abdomen channel, while passing the pulse oximetry channel.

16. The system of claim 13, comprising a monitor capable of displaying the indication of ventilatory instability.

17. The system of claim 13, wherein the processing device is capable of determining whether the indication of ventilatory instability corresponds to central sleep apnea or obstructive sleep apnea based on signals of the chest channel and/or abdomen channel.

18. The system of claim 13, comprising an integral polysomnograph system capable of providing the signals of the airflow channel, the chest channel, and the abdomen channel.

19. The system of claim 13, comprising a pulse oximetry sensor; an airflow sensor, a chest sensor, and an abdomen sensor.

20. A system, comprising:

a polysomnograph system capable of supplying signals of an airflow channel, a chest channel, an abdomen channel, and/or a pulse oximetry channel, and/or combinations thereof;

a pulse oximetry pattern recognition system capable of identifying ventilatory instability based at least in part upon a series of blood oxygen saturation values;

an event detection system capable of identifying ventilatory instability events based at least in part upon data from the airflow channel, the chest channel, the abdomen channel, and/or the pulse oximetry channel, and/or combinations thereof; and

a system calibration component capable of comparing results from the event detection system and the pulse oximetry pattern recognition system to facilitate adjustment of the pulse oximetry pattern recognition system.

专利名称(译)	检测通气不稳定的系统和方法		
公开(公告)号	US20100063366A1	公开(公告)日	2010-03-11
申请号	US12/208087	申请日	2008-09-10
[标]申请(专利权)人(译)	奥克斯JAMES BATCHELDER KEITH 平托于荣格		
申请(专利权)人(译)	奥克斯JAMES BATCHELDER KEITH PINTO YU-JUNG		
当前申请(专利权)人(译)	奥克斯JAMES BATCHELDER KEITH PINTO YU-JUNG		
[标]发明人	OCHS JAMES BATCHELDER KEITH PINTO YU JUNG		
发明人	OCHS, JAMES BATCHELDER, KEITH PINTO, YU-JUNG		
IPC分类号	A61B5/00		
CPC分类号	A61B5/0002 A61B5/087 A61B5/1135 A61B5/1455 A61B5/7282 A61B5/0816 A61B5/14551 A61B5/7203 A61B5/4818		
其他公开文献	US8398555		
外部链接	Espacenet USPTO		

摘要(译)

本文描述的实施例可以包括用于检测可能与睡眠呼吸暂停相关的事件的系统和/或方法。一些实施例涉及用于使用多导睡眠描记图信号来自动检测气流事件减少的系统和/或方法，其中气流事件的减少可以涉及睡眠呼吸暂停。PSG信号可以限于四个信号，包括来自气流通道，血氧饱和度通道，胸部运动通道和腹部运动通道的数据。使用来自这些通道的信息，一些实施例可以自动地识别气流事件的减少。

