



(19) **United States**

(12) **Patent Application Publication**
TSO

(10) **Pub. No.: US 2008/0221404 A1**

(43) **Pub. Date: Sep. 11, 2008**

(54) **MULTIFUNCTION HEALTH APPARATUS**

Publication Classification

(76) Inventor: **SHUN-WUN TSO, Miao-Li (TW)**

(51) **Int. Cl.**
A61B 5/00 (2006.01)

(52) **U.S. Cl.** **600/301**

Correspondence Address:
STOUT, UXA, BUYAN & MULLINS LLP
4 VENTURE, SUITE 300
IRVINE, CA 92618 (US)

(57) **ABSTRACT**

The present invention provides a multifunction health device, which comprises a meter and a platform. The meter has two electrodes arranged separately at its two sides or both arranged at its one side, and the meter has another electrode arranged in its bottom. The platform has four electrodes arranged in its top face, and a pressure sensor arranged in its inside. With or without some parts assisting, the single use of the meter can function as an ECG detector, a TENS machine, a thermometer, and a first sphygmomanometer. Connecting with the platform, the meter and the platform can function as an ECG detector, a weight scale, and a body composition estimator. Further, the meter can alternatively connect with a chassis thus functioning as a second sphygmomanometer, a stethoscope, a glucose meter, or a pulse oximeter.

(21) Appl. No.: **12/122,085**

(22) Filed: **May 16, 2008**

Related U.S. Application Data

(63) Continuation-in-part of application No. 11/598,128, filed on Nov. 13, 2006.

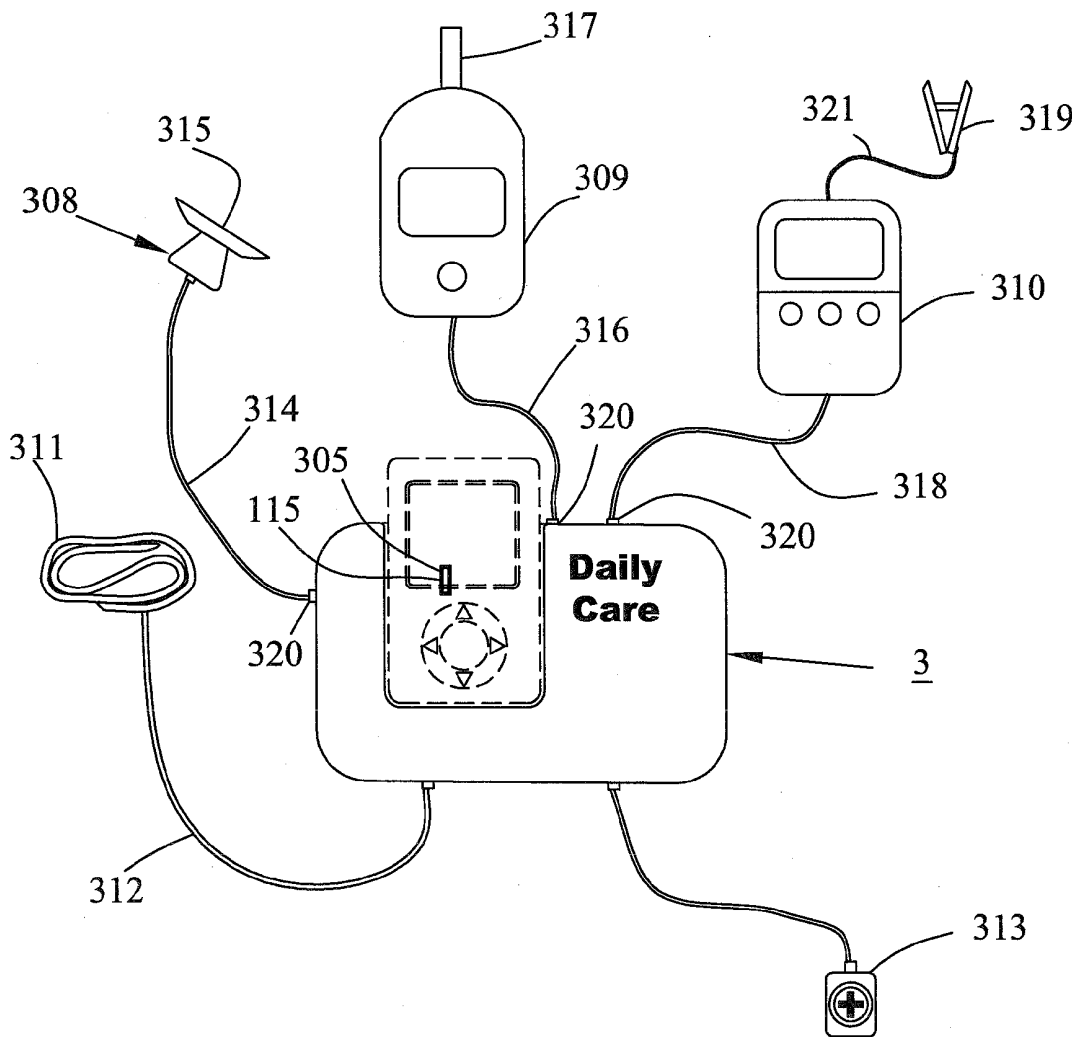

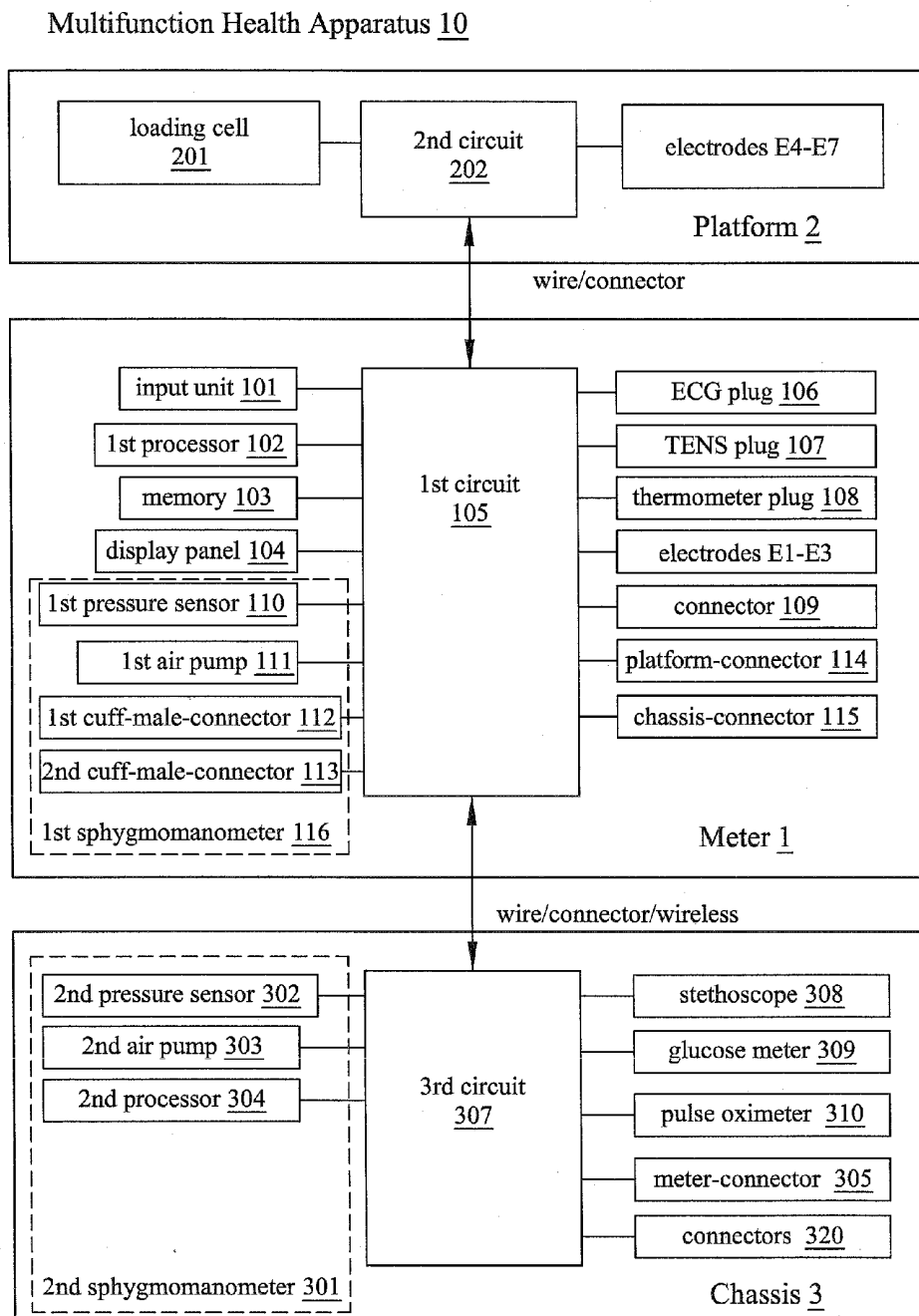

Fig. 1

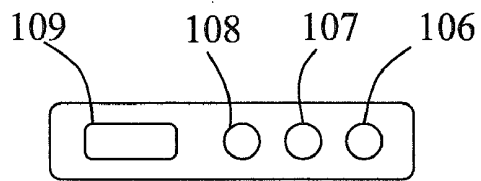

Fig. 2B

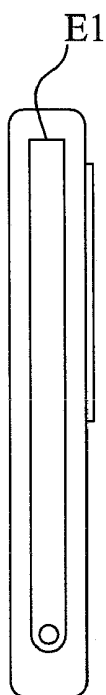

Fig. 2E

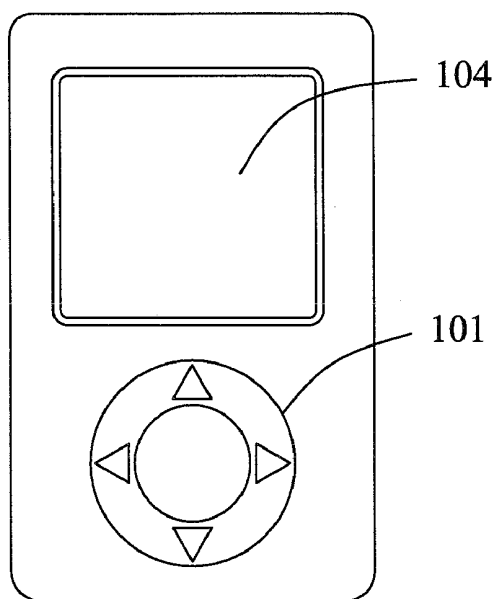

Fig. 2A

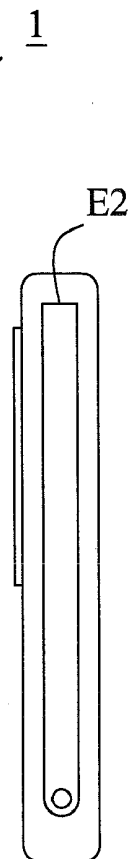

Fig. 2D

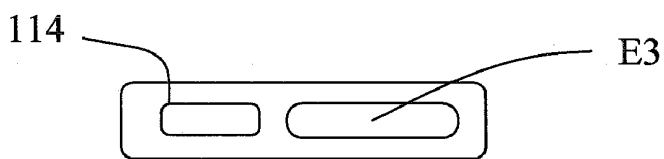

Fig. 2C

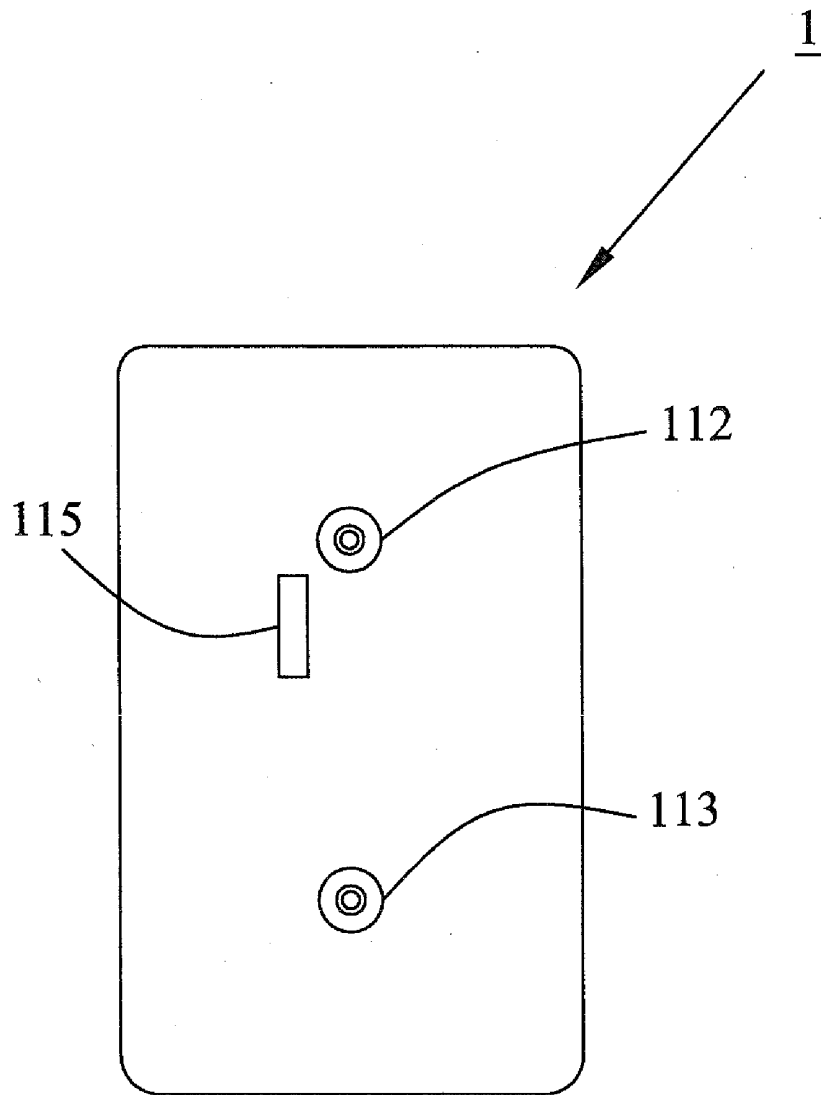

Fig. 2F

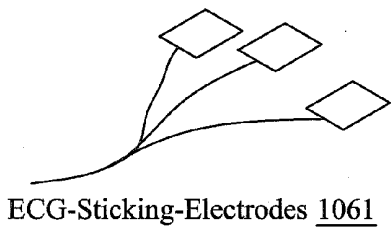

Fig. 3A

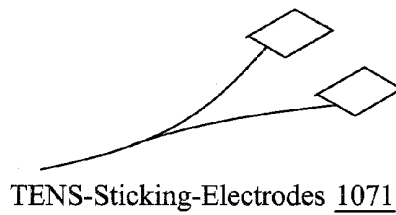

Fig. 3B

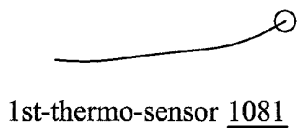

Fig. 3C

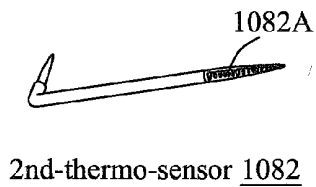

Fig. 3D

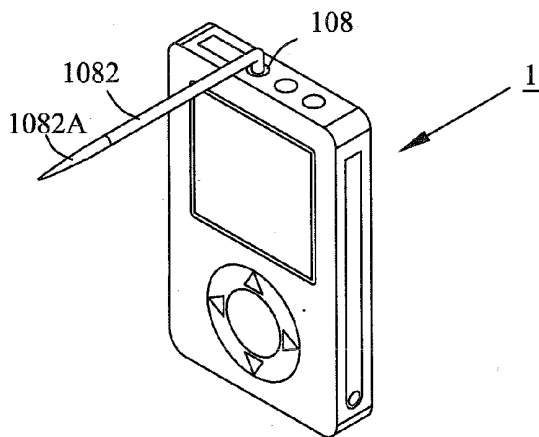

Fig. 3E

Lead 1

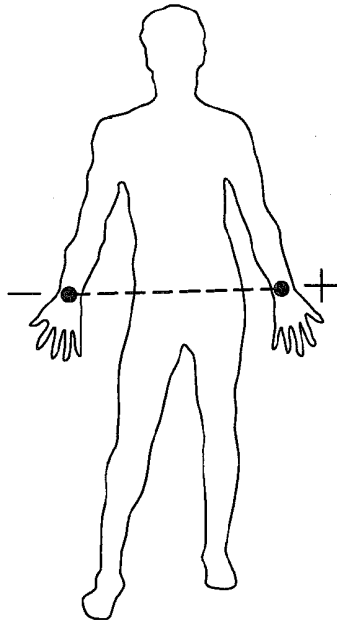

Fig. 4A

Lead 2

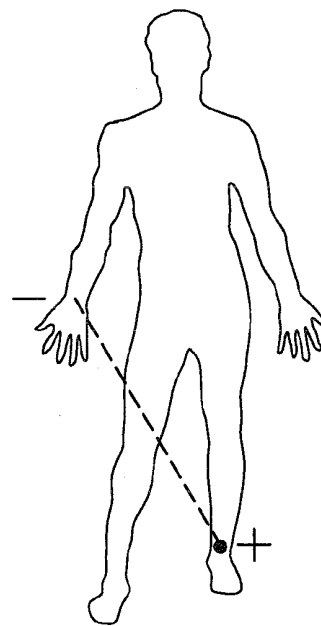

Fig. 4B

Lead 3

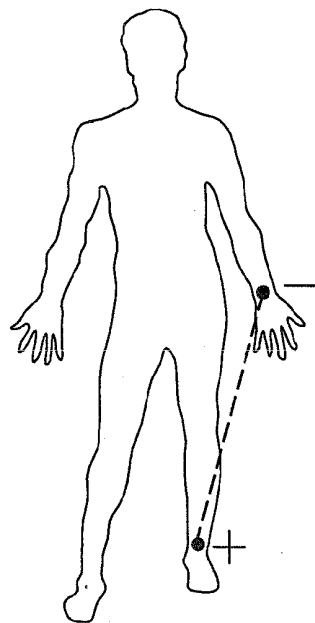

Fig. 4C

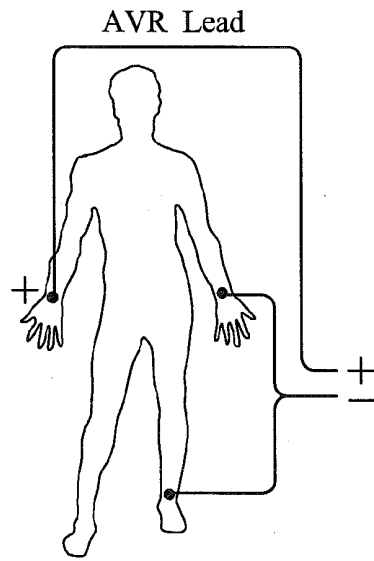

Fig. 5A

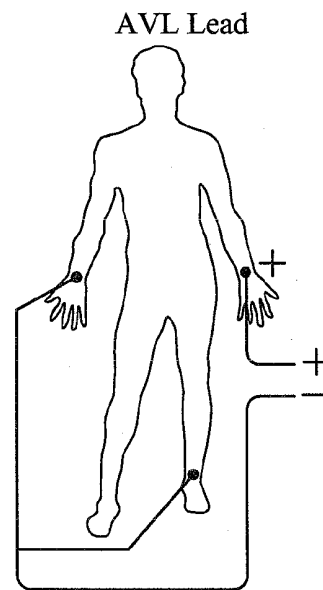

Fig. 5B

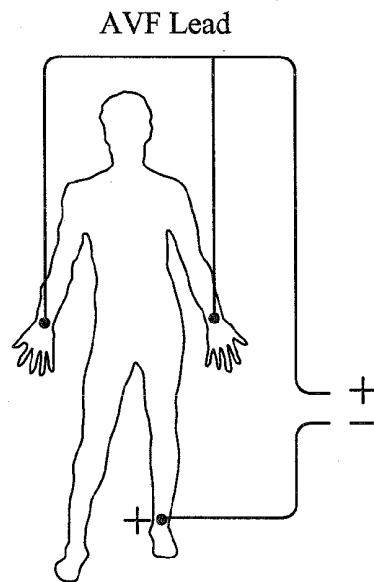
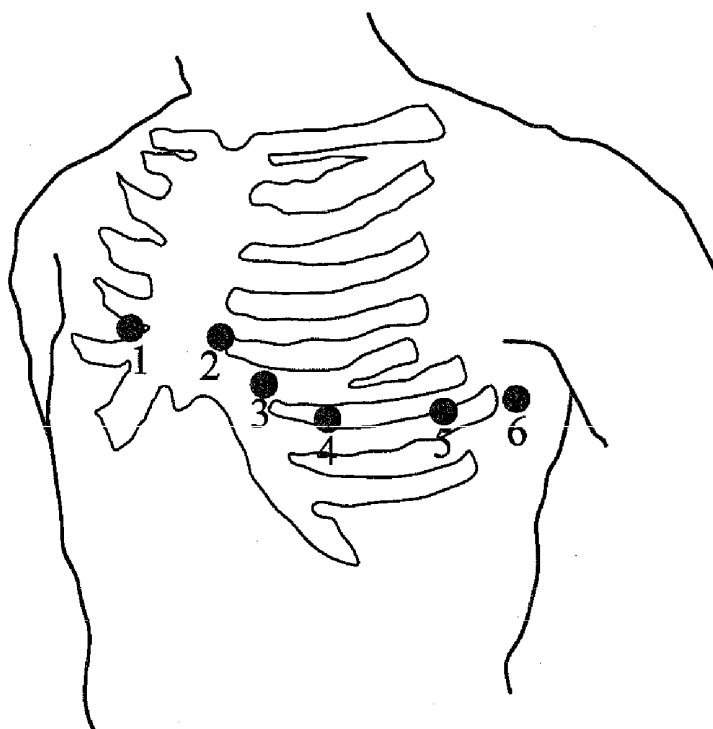

Fig. 5C



Standard six Chest Lead

Fig. 6

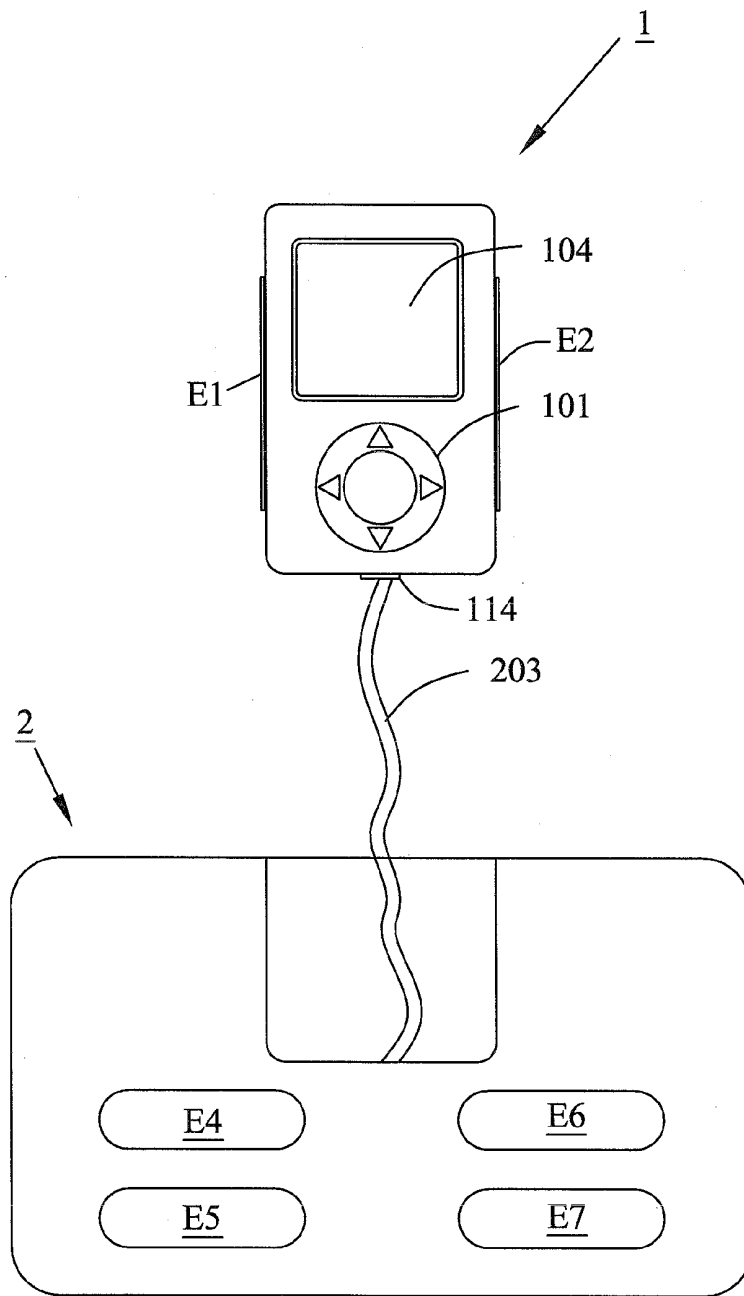

Fig. 7

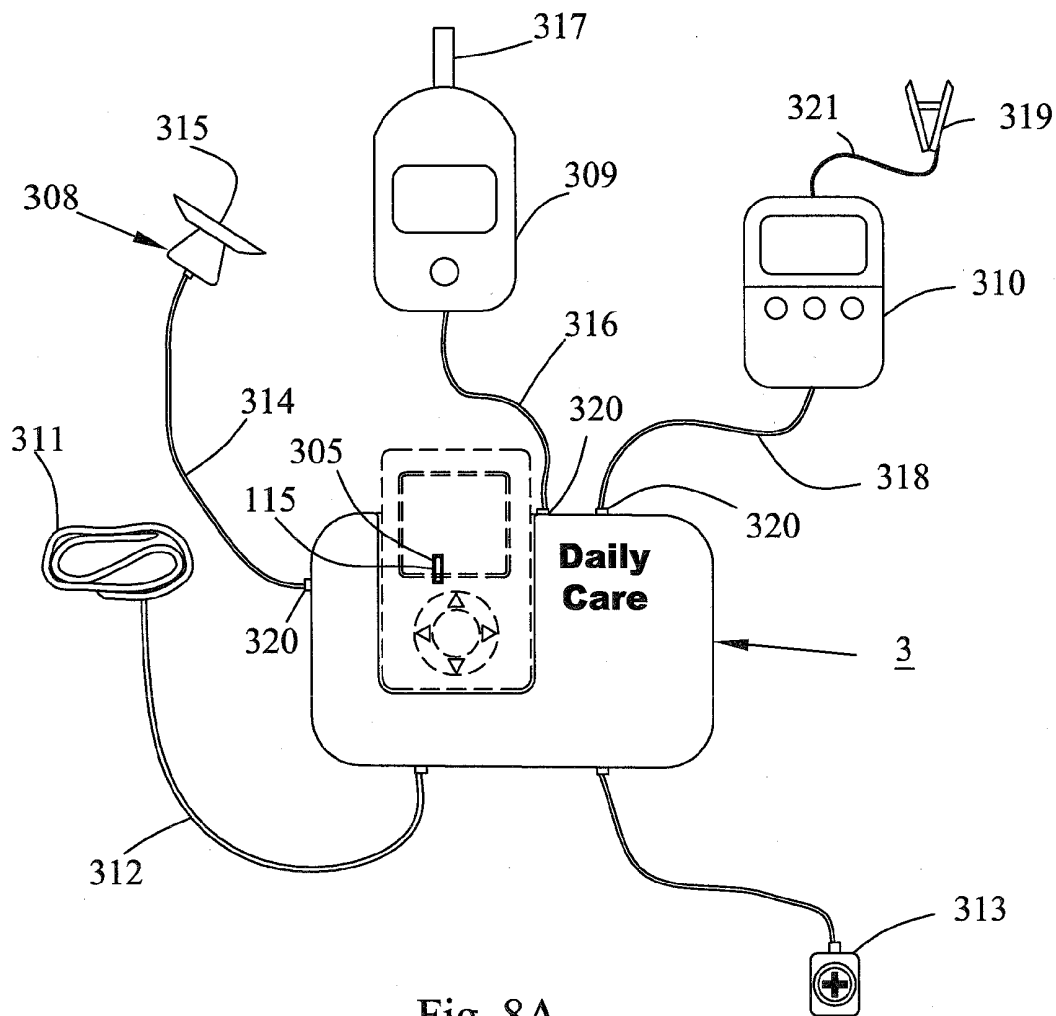

Fig. 8A

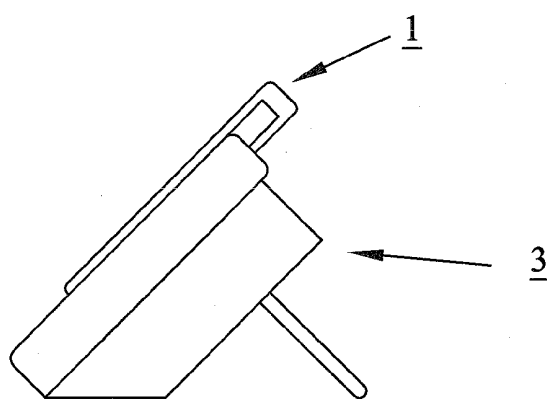

Fig. 8B

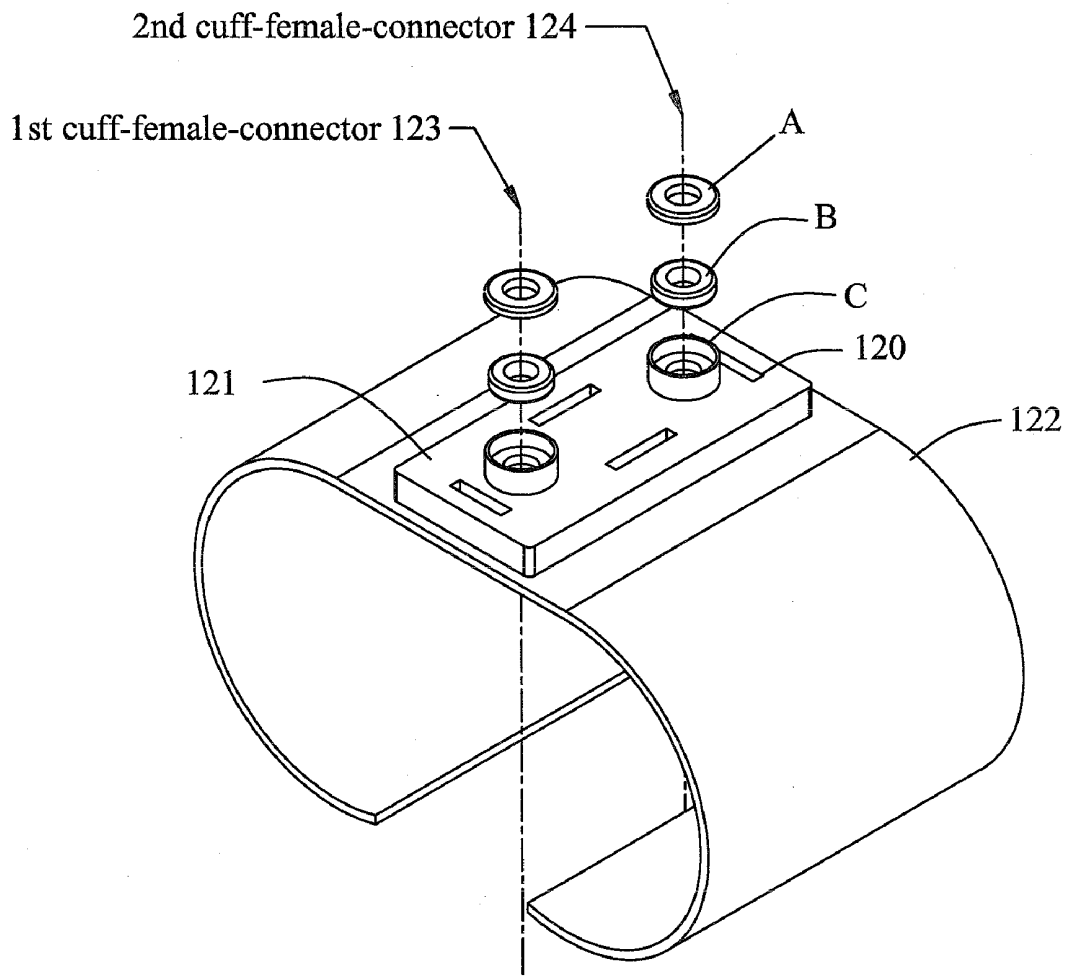

Fig. 9

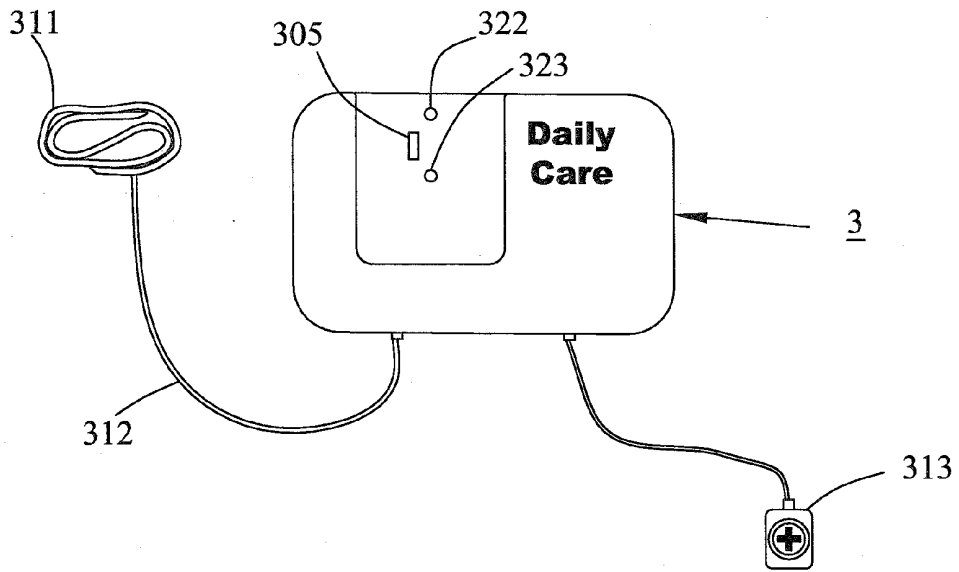

Fig. 10A

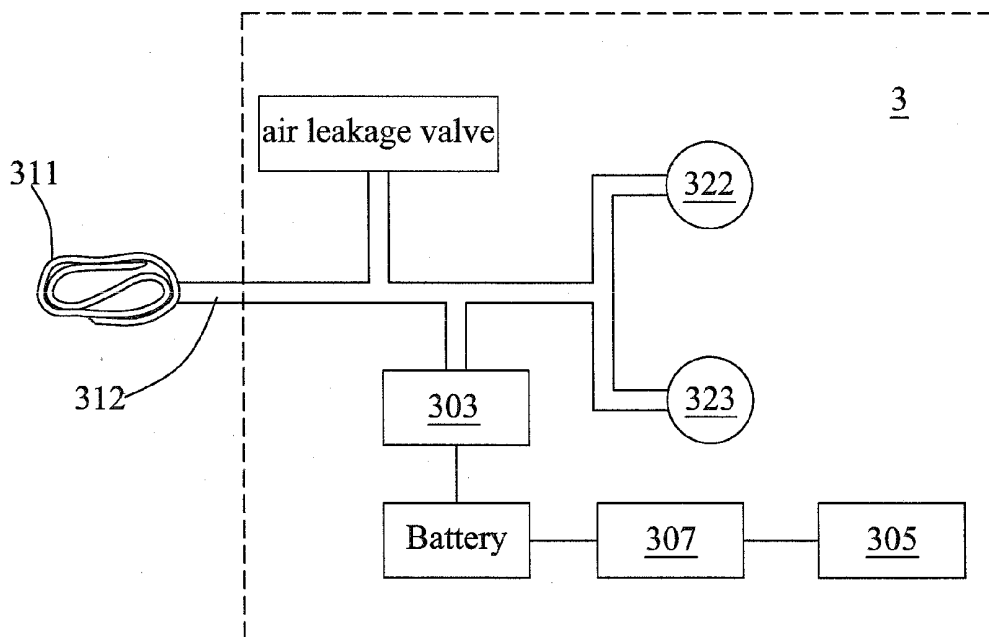

Fig. 10B

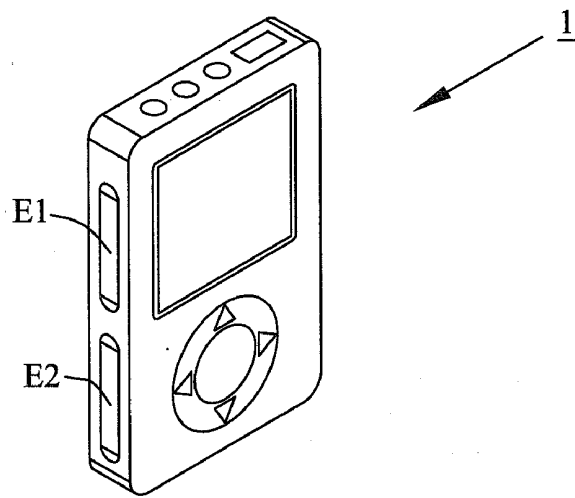

Fig. 11

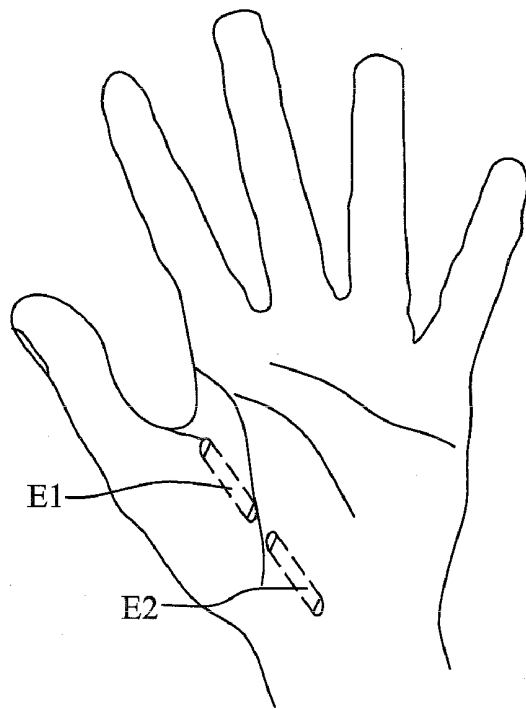

Fig. 12

MULTIFUNCTION HEALTH APPARATUS

CROSS REFERENCE TO RELATED APPLICATIONS

[0001] This application is a continuation-in-part of co-pending application Ser. No. 11/598,128, filed Nov. 13, 2006 and entitled "Multifunction Health Apparatus," the entire contents of which are incorporated herein by reference.

BACKGROUND OF THE INVENTION

[0002] 1. Field of the Invention

[0003] The present invention relates to a health apparatus, and more particularly, to a multifunction health apparatus.

[0004] 2. Description of the Prior Art

[0005] Ageing and obesity continue to be leading causes of disease. They cause some common chronic diseases such as hypertension, diabetes, and vascular disease. These diseases always need a long-term treatment, and therefore, a large cost. To reduce medical costs, home care can provide a convenient, low-cost, and effective method of assisting the patients to monitor their condition by themselves, and thus reduces the number of hospital registrations.

[0006] Because hypertension may not cause symptoms, the patients need to have blood pressure checked regularly. Blood pressure is measured with an instrument called a sphygmomanometer.

[0007] People with hypertension may have heart or vascular disease, which also needs a regular heart-condition check. Heart-condition is diagnosed by electrocardiogram. An electrocardiogram, abbreviated as ECG or EKG, is a graphic diagram recording the electrical current in the heart in a form of continuous strip graph. The ECG results provide much useful information such as, determining whether the heart is performing normally, detecting electrolyte disturbances, detecting abnormalities of conductions, and providing other data on the physical condition of the heart.

[0008] Unfortunately, heart and vascular disease often go hand-in-hand with diabetes. Diabetes occurs when the body does not produce or properly use insulin, a hormone needed to convert sugar, starches, and other food into energy for daily life. If diabetics can control their glucose, they will be more likely to stay healthy. Glucose meters can help diabetics to check their glucose at home, at the office, or in other places. It monitors whether the glucose is in balance for reducing the risk of hypoglycemia (low blood sugar) and hyperglycemia (high blood sugar).

[0009] If people suffer from hypertension, heart disease, vascular disease, or diabetes, they probably also suffer from at least two of these diseases. Therefore they probably need a sphygmomanometer, an ECG tracing machine, and a glucose meter. Because almost all of these devices are designed for single-function use, the high cost of these types of instruments is inevitable.

[0010] A key factor causing people to be diagnosed with these diseases is obesity. This can be determined not merely by a person's weight, but by examining the percentage of body fat (% BF) as well. A body fat scale can examine the body fat. However, this requires additional cost.

[0011] Unhealthy people may suffer from many pains. A Transcutaneous Electrical Nerve Stimulation (TENS) device is a common type of unit, which operates by sending electrical impulses through electrodes placed on the painful site, causing a tingling sensation that reduces pain. It helps with

chronic pain or acute pain. Unlike medicine, it has only slight side effects such as causing skin irritation. Again, this useful machine adds more cost.

[0012] Yet some other home-care units such as a weight scale, a thermometer, and a pulse oximeter are also popular. The later helps usefully in lung disease. If there is a home care apparatus capable of measuring, detecting, computing the multiple parameters mentioned above, the cost would be dramatically decreased. Moreover, if people can choose the functions in this multifunction health apparatus that they want, it would be expected to be more popular in the marketplace.

SUMMARY OF THE INVENTION

[0013] An object of the present invention is to provide a device capable of measuring multiple parameters of the human body, while simultaneously decreasing the need for multiple measurement instruments and the higher costs associated with such devices. Furthermore, people can select from among various functions in this device.

[0014] According to the object, the present invention provides a multifunction health device, which comprises a meter and a platform. The meter has two electrodes arranged separately at its two sides or arranged at the same side, and the meter has another electrode arranged in its bottom. The platform has four electrodes arranged in its top face, and a loading cell arranged in its inside. With or without some parts assisting, the single use of the meter can function as an ECG detector, a TENS machine, and a thermometer. Connecting with the platform, the meter and the platform can function as an ECG detector, a weight scale, and a body composition estimator. Further, the meter can alternatively connect with a chassis thus functioning as a display device of a sphygmomanometer, a stethoscope, a glucose meter, or a pulse oximeter, wherein the glucose meter and pulse oximeter have an individual processor. Furthermore, the sphygmomanometer, stethoscope, glucose meter, and pulse oximeter can be selectively associated in the meter or the chassis. In case of association of such functions in the meter, each may have no dedicated processor but rather may share the same processor arranged in the meter. Moreover, according to the present invention, the meter can be a cellular phone, a PDA, or the like; therefore a hospital may cooperate with a communication business to construct a real-time monitoring system for patients.

BRIEF DESCRIPTION OF THE DRAWINGS

[0015] FIG. 1 is a structure diagram of a multifunction health apparatus according to one embodiment of the present invention.

[0016] FIGS. 2A-2F respectively show a front, top, bottom, right side, left side, and rear view of the meter of one embodiment of the present invention.

[0017] FIGS. 3A-3E shows some parts of the meter according to one embodiment of the present invention.

[0018] FIGS. 4A-4C respectively show lead I, lead II, and lead III of the three standard leads.

[0019] FIGS. 5A-5C respectively show AVR Lead, AVL Lead, and AVF lead of the three augmented leads.

[0020] FIG. 6 shows the standard Six Chest Leads.

[0021] FIG. 7 shows that the meter connecting to the chassis is able to function as a body composition estimator, weight scale, and ECG detecting machine, according to one embodiment of the present invention.

[0022] FIG. 8A shows that the meter connecting to the chassis is able to function as a stethoscope, sphygmomanometer, glucose meter, or pulse oximeter, according to one embodiment of the present invention;

[0023] FIG. 8B is a side view of the chassis connecting with the meter.

[0024] FIG. 9 shows a wrist-type cuff or an arm-type cuff according to one embodiment of the present invention.

[0025] FIGS. 10A and 10B show another embodiment of the chassis according to the present invention.

[0026] FIGS. 11 and 12 show another embodiment of the meter according to the present invention.

DESCRIPTION OF THE PREFERRED EMBODIMENT

[0027] The detailed description of the present invention will be discussed in the following embodiments, which are not intended to limit the scope of the present invention, but can be adapted for other applications. While drawings are illustrated in details, it is appreciated that the quantity of the disclosed components may be greater or less than that disclosed, except expressly restricting the amount of the components.

[0028] FIG. 1 shows a block diagram of a multifunction health apparatus 10 of a preferred embodiment, according to the present invention. The multifunction health apparatus 10 includes three key devices—a meter 1, a platform 2, and a chassis 3. The meter 1 can optionally connect with one of the other two devices, by a well-known method such as wire, connector, or wireless communication. A display panel 104 of the meter 1 functions as a display device and control panel of the other two devices.

[0029] The meter 1 comprises an input unit 101, a first processor 102, a memory 103, the display panel 104, a first circuit 105, an ECG plug 106, a TENS plug 107, a thermometer plug 108, a connector 109, a first pressure sensor 110, a first air pump 111, a first cuff-connector 112, a second cuff-connector 113, a platform-connector 114, a chassis-connector 115, and three electrodes E1-E3. The input unit 101 is employed for inputting and outputting data; the first processor 102 for processing the data; the memory 103 for saving the data; the display panel 104 for displaying information and tested result; the first circuit 105 for transmitting, converting, and processing signal; the other components of the meter 1 will be discussed later. The platform 2 comprises a loading cell 201, a second circuit 202, and four electrodes E4-E7. The chassis 3 comprises a stethoscope 308, a glucose meter 309, a pulse oximeter 310, a third circuit 307, and a second sphygmomanometer 301. Where the second sphygmomanometer 301 comprises a second pressure sensor 302, a second air pump 303, and a second processor 304.

[0030] The multifunction health apparatus 10 is able to estimate, measure, or detect the multi-physiological parameters of human body. It also can function as a Transcutaneous Electrical Nerve Stimulation (TENS) machine for pain relief. The following paragraphs will respectively describe each function and measurement.

[0031] FIG. 2A-FIG. 2F respectively show the front, top, bottom, right, left, and rear view of the meter 1, according to

one embodiment of the present invention. FIG. 3A-FIG. 3E show some parts of the meter 1, according to FIG. 2A-FIG. 2F.

[0032] Without connecting to the platform 2 or the chassis 3, the meter 1 in one use can function as a TENS machine. The user selects the TENS function and controls the stimulating strength via the input unit 101. At least one pair of TENS-sticking-electrodes 1071 (FIG. 3B) is placed at appropriate pain sites on the user's body. The TENS-sticking-electrodes 1071 connect to the meter 1 via the TENS plug 107. Thus, pain relief will be started and continued after the user calls for the TENS function. If the TENS-sticking-electrodes 1071 are not applied, the electrode E3 can function as the electrode for pain relief.

[0033] Without connecting to the platform 2 or the chassis 3, single use of the meter 1 can also function as a thermometer. For one measurement, the user puts a 2nd-thermo-sensor 1082 including a metal tip 1082A (FIG. 3D) into the mouth to measure the body temperature. The metal tip 1082A is responsible for detecting the body temperature. As shown in FIG. 3E, the 2nd-thermo-sensor 1082 electrically connects to the meter 1 via the thermometer plug 108 (also shown in FIG. 1). According to the embodiment, the 2nd-thermo-sensor 1082 is also a screen-touching kit of the meter 1, an alternative of entering data by touching the display panel 104 directly. If a long time monitoring is required, then the user sticks a 1st-thermo-sensor 1081 (FIG. 3C) on the body and connects the other terminal of the 1st-thermo-sensor 1081 to the meter 1 via the thermometer plug 108. Consequently the display panel 104 will show the measuring result.

[0034] According to one embodiment of the present invention, the multifunction health apparatus 10 can also function as an ECG-detecting machine. There are four methods to detect ECG; the first employs the meter 1 only, the second employs the meter 1 with at least a set of ECG-sticking-electrodes 1061 (FIG. 3A), the third employs the meter 1 with the platform 2, and the fourth employs the platform 2 only.

[0035] Generally, the standard 12-lead electrocardiogram (ECG) represent the heart's electrical activity recorded from electrodes on the body surface. The standard 12-lead ECG includes three standard leads, three augmented leads, and six chest leads.

[0036] The three standard leads, also named bipolar leads, usually designated as lead I, II and III. FIGS. 4A-4C shows the positions of two electrodes of each standard leads. Lead I is between the right arm and left arm electrodes, the left arm being positive; Lead II is between the right arm and left leg electrodes, the left leg being positive; Lead III is between the left arm and left leg electrodes, the left leg again being positive. Actually, when testing, it is not necessary that the electrodes contact the skin in an accurate position. For example, a position needing to contact at left wrist may be changed to contact at left upper arm, left lower arm, left palm, or even left leg. The ECG result will not be affected.

[0037] According to this concept, there are various variations to detect the lead I, II and III. According to one embodiment of the present invention, the single use of the meter 1 can function as an ECG detector, that is, the electrodes E1, E2, and E3 can be used for detecting ECG. For example, while detecting lead I, the user holds the meter 1 by his left hand, then using the electrode E3 to contact right wrist. Thus the ECG result of lead I can be detected. In this situation, the electrodes E1 and E2 serve as positive, while the electrode E3 serves negative. The user can alternatively use his right hand

to hold the meter **1** and use the electrode **E3** to contact the left arm. In this situation, the electrodes **E1** and **E2** serve as negative, while the electrode **E3** serve as positive. Using the same concept, the meter **1** can detect the lead II and III. For example, the user holds the meter **1** by right hand and uses the electrode **E3** to contact left leg, thus detecting the ECG of lead II; the user holds the meter **1** by left hand and uses electrode **E3** to contact left leg, thus detecting the ECG of lead III.

[0038] The detecting methods of ECG mentioned above are suitable for short time. If longer time monitoring such as 24-hour monitoring is required, the ECG-sticking-electrodes **1061** (FIG. 3A) that are capable of sticking on the skin will be used. By sticking the electrodes of the ECG-sticking-electrodes **1061** on the positions required, connecting the other terminal to the ECG plug **106** of the meter **1** (FIG. 2B and FIG. 1), the ECG thus can be detected.

[0039] As shown in FIG. 7, connecting to the platform **2** by a wire **203** and platform-connector **114**, the meter **1** can also detect the lead I, lead II, and lead III. Here one more connector for connection between the meter **1** and the platform **2** is also applicable in another embodiment. Four electrodes—**E5**, **E6**, **E7**, and **E8**—disposed on the platform **2** will cooperate with the electrodes **E1**, **E2**, and **E3** of the meter **1** to detect ECG. For testing, the user needs to step on the platform **2** and hold the meter **1** as well. For example, while detecting lead II and III, the electrodes **E1** and **E2** serve as negative, and **E4** and **E5** serve as positive. According to the design of the present invention, ECG detecting can still proceed, if the user merely contacts one of the two same electrodes, that is, one of electrodes **E4** and **E5**, or one of electrodes **E6** and **E7**. Also for the meter **1** to employ this concept, the user needs merely to contact one of the electrodes **E1** and **E2**.

[0040] If the user steps on the platform **2**, but not holds the meter **1**, the single use of the platform **2** can detect the lead I and lead II, but fails to detect lead III. In this situation, the electrodes **E6** and **E7** serve as negative, and electrodes **E4** and **E5** serve as positive.

[0041] FIG. 5A-FIG. 5C show the three augmented leads are AVR, AVL, and AVF lead. While detecting, both the meter **1** and the platform **2** are necessary. In one embodiment, the user uses his or her right hand to hold the meter **1** (contact at least one of electrodes—**E1** or **E2**, positive), uses the meter **1** to contact left wrist by the electrode **E3** (negative), and steps on the platform **2** thus contacting the electrodes **E4** and/or **E5** by left sole (negative); therefore the AVR lead can be detected. Similarly, the AVL and AVF leads can be detected by using the same concept.

[0042] FIG. 6 shows six positions of six chest leads. The electrode **E3** of the meter **1** can be used as the detecting electrode, with corresponding detections generating six ECG results of chest leads.

[0043] According to bio-impedance measuring theory, at least two pairs of electrodes are needed to measure the impedance of the whole human body. One pair of electrodes are current supply electrodes and the other one are impedance-measuring electrodes. Then we could calculate body fat condition by the bio-impedance. If we just want to measure the impedance of the abdomen, three pairs of electrodes can be used. One pair of electrodes contacts the left foot and the second pair of electrodes contacts the right foot, the third contacts the right or left hand. Through the three pairs of electrodes we could measure the body impedance from the left hand to the right foot and from the left hand to the left foot. The difference of the two impedances should be caused

by the tissue composition of the human abdomen, and then we can get the impedance of the abdomen. Then we can calculate the fat condition or composition of the abdomen.

[0044] Referring to FIG. 7, the multifunction health apparatus **10** is able to estimate the body composition and weight by the meter **1** cooperating with the platform **2**. According to one embodiment, single frequency bioelectrical impedance analysis has been used for estimating body composition such as total body water (TBW), fat-free mass (FFM), body fat (% BF), and so forth. The embodiment uses a four-electrode method to contact impedance or skin-electrode interaction. The user stands on the platform **2** and holds the meter **1** by left hand; Simultaneously, his palm contacts the electrode **E1**, his fingers contact the electrode **E2**, his right sole contacts the electrode **E7**, his right toes contact the electrode **E6**, his left sole contacts the electrode **E5**, and his left toes contact the electrode **E4**. The two pairs of electrodes **E2** and **E6**, and electrodes **E2** and **E4**, serve as current-supply electrodes. The two pairs of electrodes **E1** and **E7**, and electrodes **E1** and **E5**, serve as impedance-measuring electrodes. The pair of **E2** and **E6**, and the pair of **E1** and **E7**, will be employed to calculate the whole body impedance, called impedance-1. The whole body impedance can calculate the body fat (% BF). The pair of **E2** and **E4**, and the pair of **E1** and **E5**, will be employed to calculate the body impedance, called impedance-2, which does not pass through the abdomen. The difference of the impedance-1 and the impedance-2 is caused by the tissue composition of the abdomen. It can be employed to calculate the fat condition of the abdomen.

[0045] In one case the user stands on the platform **2** and holds the meter **1** by his right hand; simultaneously, his right palm contacts the electrode **E2**, his fingers contact the electrode **E1**, his right sole contacts the electrode **E7**, his right toes contact the electrode **E6**, his left sole contacts the electrode **E5**, and his left toes contacts the electrode **E4**. The two pairs of electrodes **E1** and **E6**, and electrodes **E1** and **E4**, serve as current-supply electrodes. The two pairs of electrodes **E2** and **E7**, and electrodes **E2** and **E5**, serve as impedance-measuring electrodes. The pair of electrodes **E1** and **E4**, and the pair of electrodes **E2** and **E5**, will be employed to calculate the whole body impedance, called impedance-1. The whole body impedance can be used calculate the percent body fat (% BF). The pair of electrode **E1** and **E6**, and the pair of electrode **E2** and **E7**, will be employed to calculate the body impedance, called impedance-2, which does not pass through the abdomen. The difference of the impedance-1 and the impedance-2 is caused or effected by the tissue composition of the abdomen. It can be employed to calculate the fat condition or composition of fat in the abdomen.

[0046] The wire **203** actually consists of several wires (not shown). Meanwhile, a loading cell **201** (see FIG. 1, not shown in FIG. 7), mounted under the top face of the platform **2**, measures the user's weight and transfers the measured result to the meter **1** via the wire **203** and platform-connector **114**. In addition to the measured bioelectrical impedance and weight, the user must key in some parameters correlating to estimation of body composition via the input unit **101**. These parameters are height, age, and sex. This procedure can be done before or after the bioelectrical impedance and weight measurement. Therefore, the first processor **102** uses the whole body impedance, measured weight, and the inputted parameters, to estimate the user's body composition, that is, total body water (TBW), fat-free mass (FFM), body fat (% BF), and so forth. The first processor **102** transfers the estimated

result to the display panel 104. According to the embodiment of the present invention, the user can estimate his body composition easily, quickly, and painlessly, and check the estimated result via the display panel 104 held by hand without bending his back.

[0047] Referring to FIG. 1, FIG. 2F, and FIG. 9, the meter 1 cooperating with a cuff 122 can function as a 1st sphygmomanometer 116. The 1st sphygmomanometer 116 enveloped in the dashed-line rectangle of FIG. 1 comprises a 1st pressure sensor 110, a 1st air pump 111, a 1st cuff-male-connector 112, a 2nd cuff-male-connector. The 1st sphygmomanometer 116 certainly comprises some common components—the input unit 101, the 1st processor 102, the memory 103, the display panel 104, and the 1st circuit 105—sharing with other functions. Referring to FIG. 9, the 1st sphygmomanometer 116 further comprises a separated cuff 122 according to one embodiment of the present invention. Where the cuff 122 shown in FIG. 9 is represented by a circle, which is made of plastic, and should be further enveloped by an air bag (not shown). The meter 1 functions as the body of 1st sphygmomanometer 116; it connects with the cuff 122 via a 1st cuff-male-connector 112 and a 2nd cuff-male-connector 113 (see FIG. 1 and FIG. 2F). The 1st cuff-male-connector 112 connects with the 1st pressure sensor 110; the 2nd cuff-male-connector 113 connects with the 1st air pump 111; the 1st cuff-male-connector 112 plugs in a 1st cuff-female-connector 123 of the cuff 122; the 2nd cuff-male-connector 113 plugs in a 2nd cuff-female-connector 124 of the cuff 122. In this embodiment, both of the 1st cuff-female-connector 123 and the 2nd cuff-female-connector 124 comprise a cover A, an O-ring B, and a base C. The O-ring B is placed between the cover A and base C; then the cover A and base C is welded by a suitable method, such as ultrasonic welding. Further, the base C is integrated with a pedestal 121 having four slots 120 that hooked by four corresponding hooks (not shown) extruded from the cuff 122 (circled). In other embodiments, the base C may associate with the cuff by other methods. The 1st and 2nd cuff-female-connector 123/124 can provide airtight, durable connecting with the 1st and 2nd cuff-male-connector 112/113.

[0048] It is well known that electronic sphygmomanometer can be divided into wrist type and arm type. The difference between these two types is that the later needs a larger cuff, and thus larger pumping capacity of air pump. For example, the former needs a cuff inflated with 150 ml air, while the later needs 350 ml. The arm type measures the blood pressures more precisely, but the wrist type is more convenient in winter, when the user wears heavy coat. Thus, the user may need to buy both types. The separated cuff 122 of the embodiment will be a great benefit to provide a solution to solve this problem. According to the embodiment of the present invention, the arm type and the wrist type sphygmomanometer can share the meter 1. There are two cuffs 122, one type for the wrist and the other type for the arm. The cuff 122 used for wrist-type and arm-type has the same structure shown in FIG. 1, but the arm-type has a larger circle and air bag. To distinguish them, the former is called a wrist-type cuff 122, and the later is called an arm-type cuff 122. The user chooses the arm-type or the wrist-type via the display panel 104 and input unit 101, holds the meter 1 to connect with the cuff 122 on the user's wrist or upper arm, instructs the meter 1 to measure, and finally gets the result shown in display panel 105, after the 1st processor 102 estimates the blood pressure by the corresponding program stored in the memory 103.

[0049] If longer monitoring of blood pressure is needed, user will feel uncomfortable when the meter 1 is mounted on the arm or wrist for a period of time. The present invention provides another solution to solve this problem. Referring back to FIG. 1, it shows the multifunction health apparatus 10 can also function as a 2nd sphygmomanometer 301, a stethoscope 308, a glucose meter 309, or a pulse oximeter 310 by connecting the meter 1 to the chassis 3, where the 2nd sphygmomanometer 301 comprises a second pressure sensor 302, a 2nd air pump 303, and a 2nd second processor 304.

[0050] FIG. 8A shows one embodiment of the chassis 3 according to FIG. 1, the meter 1 connects to the chassis 3 to function as the display device. FIG. 8B is the side view of the chassis 3. Some component arranged inside the chassis 3 are not shown such as the second pressure sensor 302, the second air pump 303, the second processor 304, and the third circuit 307.

[0051] In this embodiment, the chassis 3 connects to the meter 1 via a chassis-connector 115 and a meter-connector 305, and both of them are golden-finger connector. In other embodiments, their connecting may use any other kind of connection such as wire or wireless communication. When functioning as the second sphygmomanometer 301, the user wears the cuff 311 on his upper arm and pushes the start button 313, causing the second air pump 303 (not shown) to supply air through the air inlet valve (not shown) to the cuff 311 via the tube 312. It is noted that the cuff 311 differs from the wrist-type or arm-type cuff 122 mentioned above; the cuff 311 has a hook-and-loop fastener on its surface. When the cuff pressure reached the predetermined value, the air within the cuff 311 is turned to discharge at a constant speed via the air leakage valve (not shown). The cuff pressure decreases gradually. The second pressure sensor 302 senses the variation of the cuff pressure, transferring and converting it to the second processor 304 through the third circuit 307. According to the pressure variation of the cuff 311, the second processor 304 calculates the systolic pressure and diastolic pressure. The second processor 304 transfers the calculated result to the meter 1 through the third circuit 307 for showing in its display panel 104.

[0052] As mentioned above, the cuff 311 and arm-type cuff 122 have larger air bag, consequently larger volume that needs larger air pump to pump it. Thus it is reasonable to choose the first air pump 111 and the second air pump 303 having pumping capacity that can meet the requirement of the cuff 311 and arm-type cuff 122. On the topic of cost saving, however, the present invention provides another embodiment that can further reduce expenditure of such costs.

[0053] FIGS. 10A and 10B show this other embodiment of the present invention. Differing from the previous embodiment, the chassis 3 further comprises a first chassis-female-connector 322 and a second chassis-female-connector 323; both have the same structure as the first cuff-female-connector 123 and the second cuff-female-connector 124. When the first cuff-male-connector 112 plugs in the first chassis-female-connector 322, and the second cuff-male-connector 113 plugs in the second chassis-female-connector 323, the first chassis-female-connector 322 will connect to the first pressure sensor 110 of the meter 1, and the second chassis-female-connector 323 will connect to the first air pump 111. Therefore, the second air pump 303 of the chassis 3 can be omitted. Further, the size of the meter 1 may be relatively small in accordance to a customer's request. Thus the first air pump 111 inside the meter 1 may have pumping capacity capable of

pumping the wrist-type cuff 122, but fail to pump the arm-type cuff 122 or cuff 311, because the volume of the meter 1 may be too small to put the larger first air pump 111 inside. According to the present invention, the meter can be as small as, for example, L74 mm*W64 mm*T24 mm. Moreover, in this embodiment, for saving cost, the second air pump 303 also has pumping capacity capable of inflating the wrist-type cuff 122, but not (e.g., does not pump) the arm-type cuff 122 or cuff 311. And the first air pump 111 of the meter 1 and the second air pump 303 of the chassis 3 will cooperate to inflate the cuff 311 through the tube 312. When the meter 1 connects to the chassis 3 via the chassis-connector 115 and the meter-connector 305, the first processor 102 of the meter will automatically use the program, stored in the memory 103, suitable for the arm-type, to compute the blood pressure. Alternatively, the user manually instructs the meter 1 to enter the arm-type state. The meter 1 instructs the first air pump 111 to inflate the cuff 311 through the second chassis-female-connector 323, and instructs the second air pump 303 to inflate the cuff 311 through meter-connector 305, third circuit 307, and battery. When cuff pressure of the cuff 311 reaches the predetermined value, the air within the cuff 311 is turned to discharge at a constant speed via the air leakage valve. The cuff pressure decreases gradually. The first pressure sensor 112 senses the variation of the cuff pressure, transferring and converting it to the first processor 102 through the first circuit 105. According to the pressure variation of the cuff 311, the first processor 102 calculates the systolic pressure and diastolic pressure. Finally the first processor 102 transfers the calculated result to the display panel 104.

[0054] If the second air pump 303 in the embodiment shown in FIGS. 10A and 10B has pumping capacity capable of inflating the cuff 311, then the second chassis-female-connector 323 should be omitted. It is practicable in another embodiment that omits the second chassis-female-connector 323, the second processor 304, second processor, but remains the first chassis-female-connector 322.

[0055] Referring back to FIG. 8A, this embodiment shows the chassis 3 connecting to the meter 1 can also function as a stethoscope 308. A transducer 315 is used for transferring the signal from the surface of the skin to the chassis 3 via a wire 314 and one of a plurality of the connectors 320. The transducer 315 may be any other kind, such as a microphone or an accelerometer. After receiving the signal, a plurality of amplifiers and A/D converter of the third circuit 307 dealt with the signal, then transfer to the meter 1 to show the amplified signal in the display panel 104.

[0056] For detecting the glucose concentration of blood, the user has to connect the glucose meter 309 to the chassis 3 via a wire 316 and one of a plurality of the connectors 320. In this embodiment, the user also has to get the blood sample and puts it in the sample carrier 317. Some components inside the glucose meter 309 are not shown, such as a light source, a receiver, a biosensor, a third processor, and other necessary circuits. The light source emits a testing light to the blood sample in the sample carrier 317. The biosensor detects the optical spectrum by the reflection or transmission of the testing light. The receiver receives the optical spectrum, transferring to the third processor (not shown) to calculate the glucose concentration. Finally the display panel 104 of the meter 1 shows the result.

[0057] According to the present invention, glucose concentration may be detected by other methods, such as the elec-

trical chemistry method. In this case, adding some enzymes in the sample carrier 317 is necessary to test the bio-current in the blood sample.

[0058] Another embodiment of the present invention omits the third processor (not shown), instead of it; the first processor 102 inside in the meter 1 will be responsible for controlling the other components and calculating the glucose concentration, according to the signal transferred from the receiver. In this case, the wire 316 should be connected to the meter 1, not the chassis 3.

[0059] For detecting the oxygen saturation, the user uses the probe 319 to cramp his finger. The probe 319 connects the pulse oximeter 310 via a wire 321. A pair of LEDs (light emitting diodes, not shown) and at least one corresponding detector (not shown) is mounted on the probe 319. The two LEDs respectively emit the red and infrared light at predetermined wavelength to the finger cramped by the probe 319. The at least one detector detects the spectrum of light transmitted or reflected from the finger. In this embodiment, a fourth processor (not shown) is arranged inside the pulse oximeter 310 to receive the spectrum of light and thus compute the oxygen saturation and pulse beat. The computed results are transferred to the meter 1 via the wire 318 and connector 320. The display panel 104 of the meter 1 shows the result for the customer.

[0060] Again, another embodiment of the present invention omits the fourth processor (not shown). Instead of it, the first processor 102 inside in the meter 1 will be responsible for controlling the other components inside in the pulse oximeter 310, and computing the oxygen saturation and pulse beat. In this case, the wire 318 should be connected to the meter 1, not the chassis 3.

[0061] Among these embodiments mentioned above, the stethoscope 308, glucose meter 309, and pulse oximeter 310 connect to the chassis 3 or the meter 1 via the plurality of connectors 320. In case of connecting to the meter 1, only one processor is needed, that is, the first processor 102 is responsible for all control and computation works. Further, the plurality of connectors 320 is a USB (Universal Serial Bus) connector, and it may be any other kind in other embodiments. In addition, the meter 1 has at least one connector 109 for connecting to other devices such as a computer or printer. The connector 109 is also a USB connector; it may be other kinds of connectors. Moreover, the meter 1 may be a cellular phone, a PDA (Personal Digital Assistant), MP3 (Moving Picture Experts Group audio layer-3) player, or the like; therefore a hospital may cooperate with a communication business to construct a real-time monitoring system for the patients.

[0062] In the embodiment of the present invention, the input unit 101 has button-type components; in other embodiments, the input unit 101 may be other types, such as voice-activated type, scan type, hand-written type, code data readers, or the like.

[0063] The present invention might have other modifications. For example, FIGS. 11-12 show another embodiment of the meter according to the present invention. The difference between this embodiment and other embodiments is that the electrodes E1 and E2 are not arranged separately at two sides, but are arranged at one side of the meter 1, and the electrode E1 and electrode E2 remain a distance, as shown in FIG. 11. The experiments show better stability when the electrodes E1 and E2 are arranged as FIG. 11, especially for estimating the body composition. This embodiment uses the

similar theory as other embodiments discussed before to detect ECG and estimate body composition; the detail is omitted. FIG. 12 shows that the left palm will contact E1 and E2. In this embodiment, the electrodes E1 and E2 are arranged suitably to be held by the left hand; in another embodiment, the electrodes E1 and E2 are arranged suitably to be held by the right hand. Moreover, in accordance with one practicable embodiment the electrodes E1 and E2 are arranged at one side of the meter 1, another pair of electrodes E8 and E9 (not shown) is arranged at the other side of the meter 1, and the first processor 102 decides which pair is to be chosen to do the work when a test is requested. As shown in FIG. 12, because both of the electrodes E1 and E2 contact the hand in the palm rather than on the fingers, a more stable test result is reasonably expected.

[0064] According to the present invention, a user can choose the functions associated in this device depending on his need or requirement. For example, a multifunction health apparatus 10 of one embodiment comprises the meter 1, and the meter 1 comprises a first sphygmomanometer 116 but no electrodes E1-E3 as a consequence of, for example, the user suffering from hypertension but not obesity, or just for cost savings.

[0065] Although specific embodiments have been illustrated and described, it will be appreciated by those skilled in the art that various modifications may be made without departing from the scope of the present invention, which is intended to be limited solely by the appended claims.

What is claimed is:

1. A multifunction health device, comprising:
 - a meter, the single use of said meter being able to optionally function as a electrocardiogram (ECG) detector, transcutaneous electrical nerve stimulation (TENS) machine, and a thermometer, said meter comprising an input unit for inputting and outputting data, a first processor for processing the data, a memory for saving the data, a display panel for displaying information and test results, a first circuit for transmitting, converting, and processing signals, a first electrode and a second electrode arranged separately at the two sides of said meter or both arranged at one side of said meter, a third electrode arranged at the bottom of said meter, said first electrode, second electrode, and third electrode assisting in ECG detecting and TENS.
2. The multifunction health device as recited in claim 1, further comprising:
 - a platform, allowing for stepping-on by the user, connecting with said meter being able to function as an ECG detector, a weight scale, and a body composition estimator, said platform comprising a fourth electrode for contacting the user's left-front sole, a fifth electrode for contacting the user's left-rear sole, a sixth electrode for contacting the user's right-front sole, a seventh electrode for contacting the user's right-rear sole, a loading cell arranged under the top face of said platform for sensing the user's weight, a second circuit transmitting, converting, and processing signal, then the signal being transferred to said first processor of said meter, then being displayed on said display panel of said meter.
3. The multifunction health device as recited in claim 1, further comprising:
 - a chassis, connecting with said meter and being able to function as a sphygmomanometer, said chassis comprising a second air pump for raising pressure of a cuff worn

by the user, an air inlet valve for sucking air into the air pump, an air outlet valve for air leakage of the cuff, a second pressure sensor for measuring the pressure of the cuff, a second processor for processing the tested pressure signal, a third circuit for transmitting, converting, and processing the signal, then the signal being transferred to said meter and being displayed on said display panel.

4. The multifunction health device as recited in claim 3, wherein the chassis further comprises at least one of the connectors for connecting a stethoscope, a glucose meter, or a pulse oximeter, said glucose meter and pulse oximeter sharing a processor, said stethoscope, glucose meter, and pulse oximeter using said meter as a display device.

5. The multifunction health device as recited in claim 1, further comprising:

- a first pressure sensor arranged inside said meter;
- a first air pump arranged inside said meter;
- a first cuff-male-connector connecting to said first pressure sensor; and
- a second cuff-male-connector connecting to said first air pump.

6. The multifunction health device as recited in claim 5, further comprising:

- an arm-type or wrist-type cuff separated from said meter having a first cuff-female-connector and a second cuff-female-connector, wherein both of said first cuff-female-connector and second cuff-female-connector comprise a base associated with said cuff, a cover arranged on said base and welding with said base, and an O-ring arranged between said cover and said base;

whereby said first cuff-male-connector plugs in said first cuff-female-connector, said second cuff-male-connector plugs in said second cuff-female-connector, said first air pump inflating said arm-type or wrist-type cuff through said second cuff-male-connector and said second cuff-female-connector, said first pressure sensor sensing pressure through first cuff-male-connector and said first cuff-female-connector, said first processor estimates the result, and said display panel shows the result.

7. The multifunction health device as recited in claim 5, further comprising:

- a chassis, connecting with said meter being able to function as a sphygmomanometer, said chassis comprising a second air pump for partly raising pressure of a cuff worn by the user, an air leakage valve for air leakage of the cuff, a first chassis-female-connector for connecting with said first pressure sensor via said first cuff-male-connector, a second chassis-female-connector for connecting said first air pump via second cuff-male-connector, thus said cuff being inflated via said first air pump and said second air pump, said first pressure sensor sensing the variation of cuff pressure, and a third circuit for transmitting, converting, and processing signal, then the signal being transferred to said meter and being displayed on said display panel.

8. The multifunction health device as recited in claim 7, wherein the chassis further comprises at least one of the connectors for connecting a stethoscope, a glucose meter, or a pulse oximeter, said glucose meter and pulse oximeter sharing an individual processor, said stethoscope, glucose meter, and pulse oximeter using said meter as a display device.

9. The multifunction health device as recited in claim 1, further comprising:

a chassis, connecting with said meter being able to function as a sphygmomanometer, said chassis comprising a second air pump for raising pressure of a cuff worn by the user, an air leakage valve for air leakage of the cuff, a first chassis-female-connector for connecting with said first pressure sensor via said first cuff-male-connector, thus said first pressure sensor sensing the variation of cuff pressure, and a third circuit for transmitting, converting, and processing signal, then the signal being transferred to said meter and being displayed on said display panel.

10. The multifunction health device as recited in claim **9**, wherein the chassis further comprises at least one of the connectors for connecting a stethoscope, a glucose meter, or a pulse oximeter, said glucose meter and pulse oximeter having an individual processor, said stethoscope, glucose meter, and pulse oximeter using said meter as a display device.

11. The multifunction health device as recited in claim **1**, wherein when said meter is implemented in a single use to detect ECG, the first electrode, second electrode, and third electrode are employed to detect the three standard lead (lead I, lead II, lead III) and six chest lead.

12. The multifunction health device as recited in claim **1**, wherein said meter further comprises a set of ECG-sticking-electrodes as an auxiliary part for ECG detecting including three standard lead (lead I, lead II, lead III), AVR lead, AVL lead, AVF lead, and six chest lead.

13. The multifunction health device as recited in claim **1**, wherein said meter further comprises a first-thermo-sensor as an auxiliary part for temperature measuring, when functioning as a thermometer, said meter connects with said first-thermo-sensor that sticks on the local area of the user.

14. The multifunction health device as recited in claim **1**, wherein said meter further comprises a second-thermo-sensor as an auxiliary part for alternative of temperature measuring, when functioning as a thermometer, said meter connects with said second-thermo-sensor having a metal tip held in the user's mouth to detect the user's body temperature.

15. The multifunction health device as recited in claim **14**, wherein said second-thermo-sensor is also a screen-touching kit of said meter.

16. The multifunction health device as recited in claim **1**, wherein said meter further comprises at least one pair of TENS-sticking-electrodes as an auxiliary part for TENS.

17. The multifunction health device as recited in claim **1**, when functioning as a TENS machine, said meter uses said third electrode to contact the local area of user for pain relief.

18. The multifunction health device as recited in claim **1**, wherein the user's body composition at least including body water (TBW), fat-free mass (FFM), and body fat (% BF) are estimated, after the user inputs personal information, at least including height, age, and sex, via said input unit.

19. The multifunction health device as recited in claim **1**, wherein said meter further receives a measured signal from a stethoscope, a glucose meter, or a pulse oximeter, said first processor processing the measured signal, said first circuit transmitting, converting, and processing the signal, and said display panel displaying the result for the user.

20. The multifunction health device as recited in claim **1**, wherein said meter further receives a measured signal from a stethoscope, a glucose meter, or a pulse oximeter, the combination of said stethoscope, a glucose meter, or a pulse oximeter having an individual processor for processing the signal, said first circuit transmitting, converting, and processing the signal, and said display panel displaying the result for the user.

21. The multifunction health device as recited in claim **1**, when said first electrode and a second electrode are both arranged at one side of said meter, then said meter further comprises an eighth electrode and a ninth electrode arranged at the other side of said meter.

22. The multifunction health device as recited in claim **1**, wherein said meter comprises a cellular phone, a PDA (Personal Digital Assistant), or a MP3 (Moving Picture Experts Group audio layer-3) player.

* * * * *

专利名称(译)	多功能保健器具		
公开(公告)号	US20080221404A1	公开(公告)日	2008-09-11
申请号	US12/122085	申请日	2008-05-16
[标]申请(专利权)人(译)	TSO顺WUN		
申请(专利权)人(译)	曹顺WUN		
当前申请(专利权)人(译)	曹顺WUN		
[标]发明人	TSO SHUN WUN		
发明人	TSO, SHUN-WUN		
IPC分类号	A61B5/00		
CPC分类号	A61B5/02055 A61B5/02233 A61B5/0402 A61B5/0537 A61B2560/0468 A61B5/1455 A61B5/4872 A61B2560/0456 A61B5/14532 A61B5/4041		
外部链接	Espacenet USPTO		

摘要(译)

本发明提供一种多功能健康装置，包括仪表和平台。仪表在其两侧分开布置两个电极，或者在其一侧布置两个电极，并且仪表在其底部布置有另一个电极。平台在其顶面上布置有四个电极，并且在其内部布置有压力传感器。有或没有一些部件辅助，仪表的单独使用可以用作ECG检测器，TENS机器，温度计和第一血压计。与平台连接，仪表和平台可以用作ECG检测器，体重秤和身体成分估计器。此外，仪表可以替代地与底座连接，因此用作第二血压计，听诊器，血糖仪或脉搏血氧计。

