



(19) **United States**

(12) **Patent Application Publication**

Starr et al.

(10) **Pub. No.: US 2004/0171950 A1**

(43) **Pub. Date: Sep. 2, 2004**

(54) **METHOD AND APPARATUS FOR DETERMINING CARDIAC OUTPUT**

continuation of application No. 09/691,595, filed on Oct. 18, 2000, now Pat. No. 6,413,226.

(75) Inventors: **Eric W. Starr**, Allison Park, PA (US);
Bernard Pennock, Oakmont, PA (US);
Mouhyieldin Kandis, Haledon, NJ (US)

(60) Provisional application No. 60/161,120, filed on Oct. 22, 1999.

Publication Classification

(51) **Int. Cl.⁷** **A61B 5/02**
(52) **U.S. Cl.** **600/508**

Correspondence Address:
MICHAEL W. HAAS, INTELLECTUAL PROPERTY COUNSEL
RESPIRONICS, INC.
1010 MURRY RIDGE LANE
MURRYSVILLE, PA 15668 (US)

(57) **ABSTRACT**

A method and apparatus for use in determining the cardiac output. The method include quantitatively measuring the patient's airflow, a first parameter indicative of the percent oxygen inhaled and exhaled by the patient, and a second parameter indicative of the patient's fractional arterial oxygen concentration. The method also includes inducing a change in the patient's arterial oxygen concentration while taking these measurements to monitor the effects of the change in the patient's arterial oxygen concentration. The cardiac output is determined from the data collected regarding the effects of the change in the patient's arterial oxygen concentration.

(73) Assignee: **Respironics, Inc.**, Murrysville, PA

(21) Appl. No.: **10/763,971**

(22) Filed: **Jan. 23, 2004**

Related U.S. Application Data

(63) Continuation of application No. 10/172,271, filed on Jun. 14, 2002, now Pat. No. 6,699,203, which is a

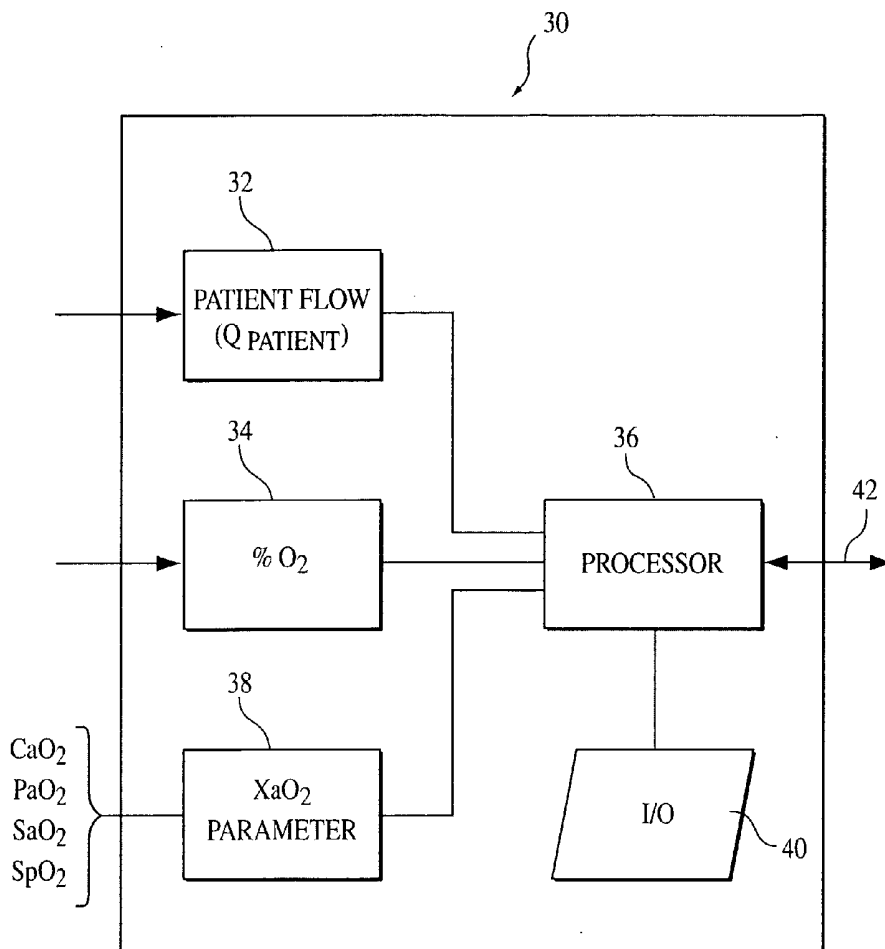

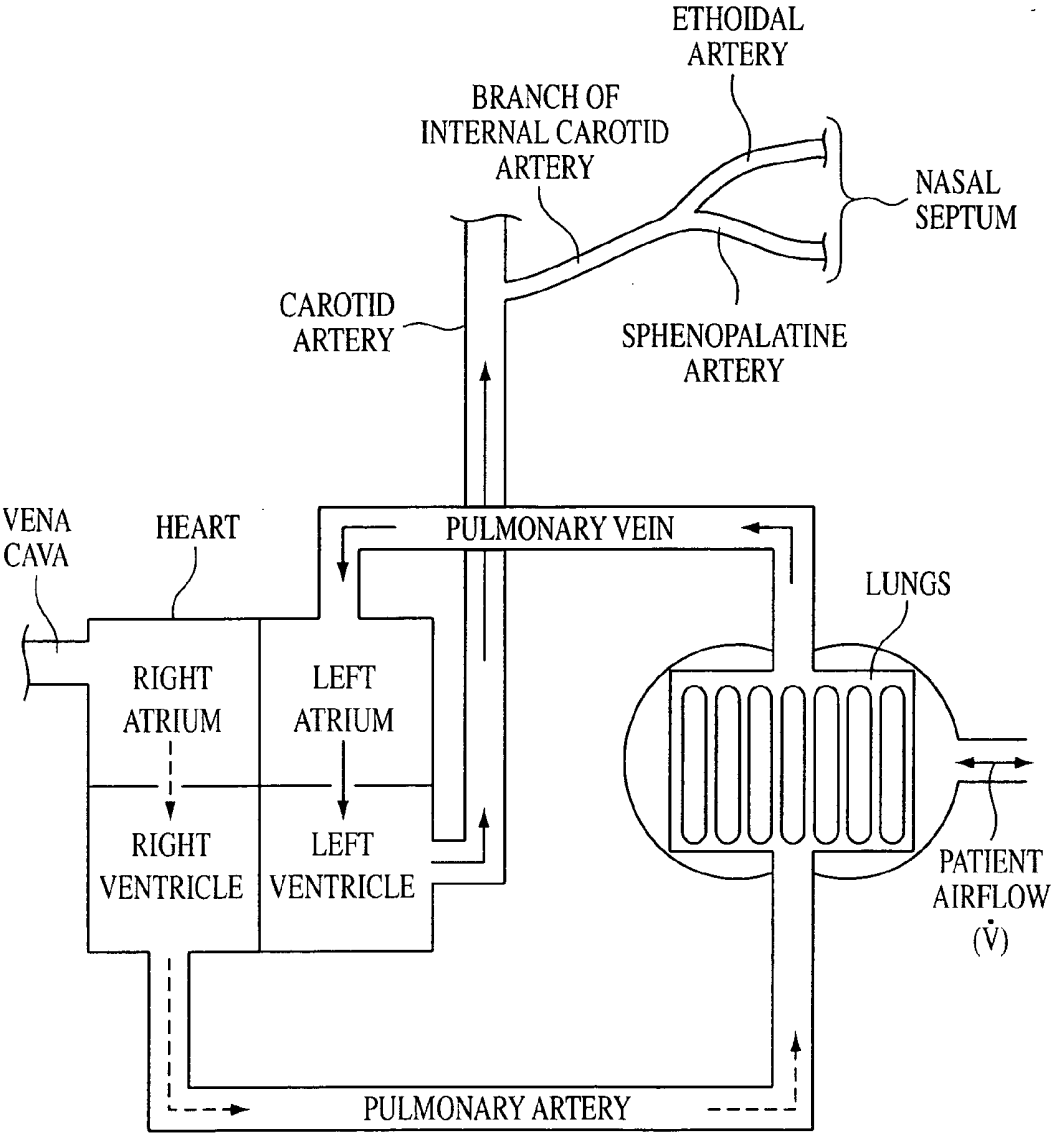

FIG. 1

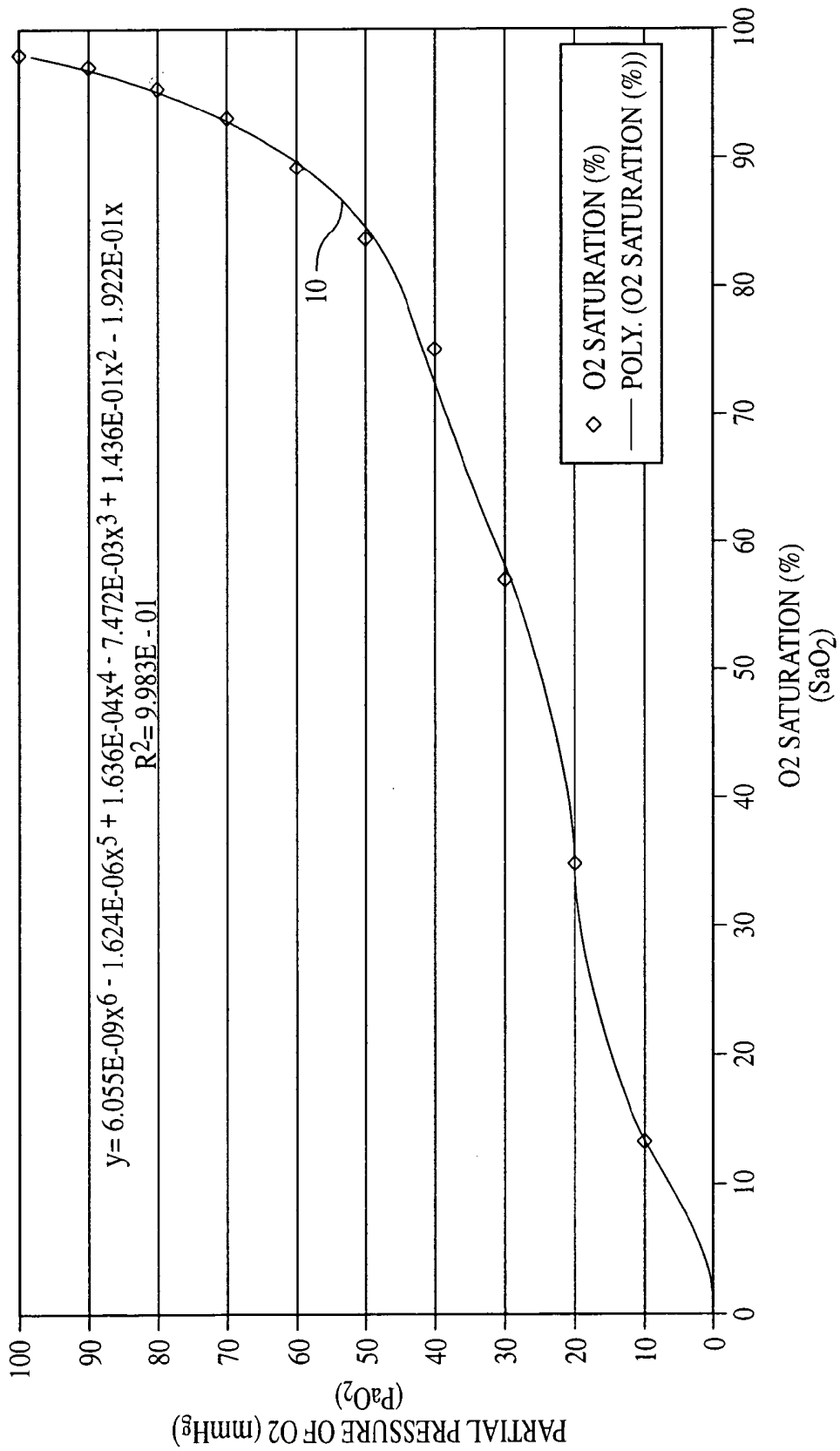

FIG. 2

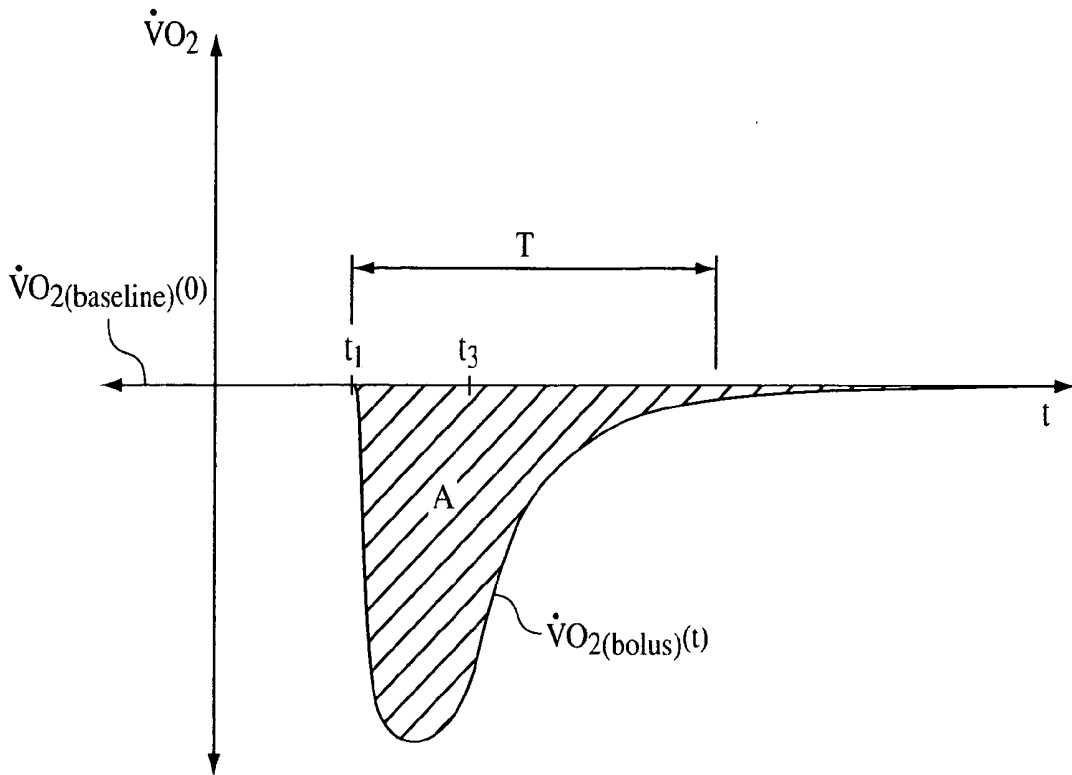

FIG. 3A

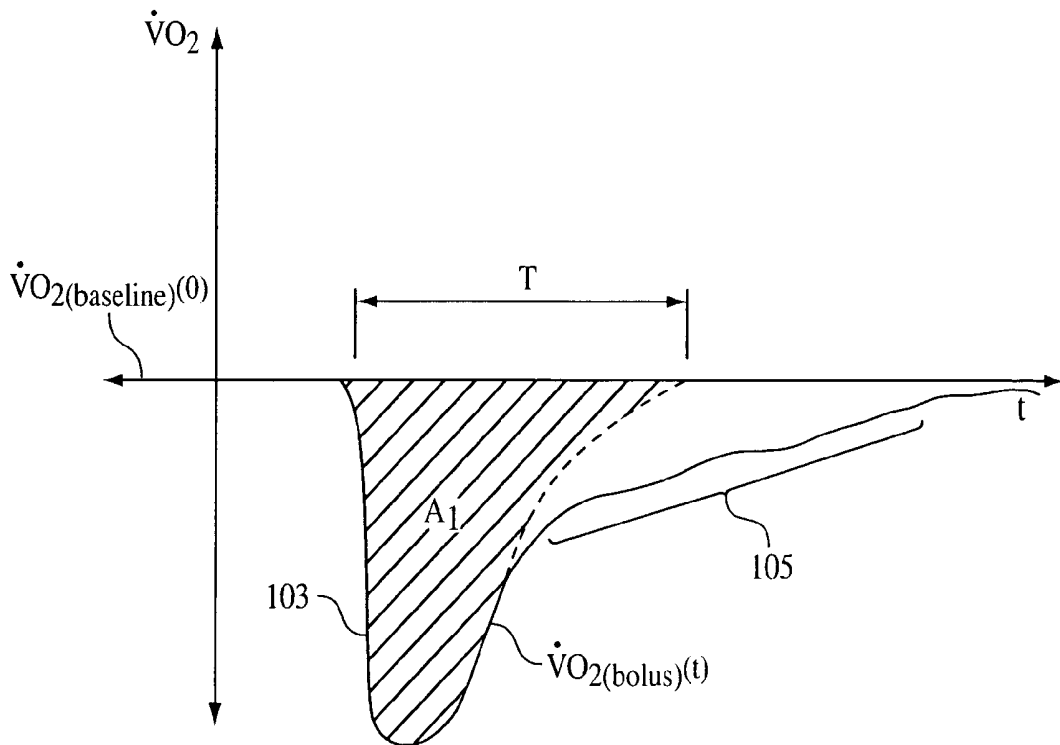

FIG. 5A

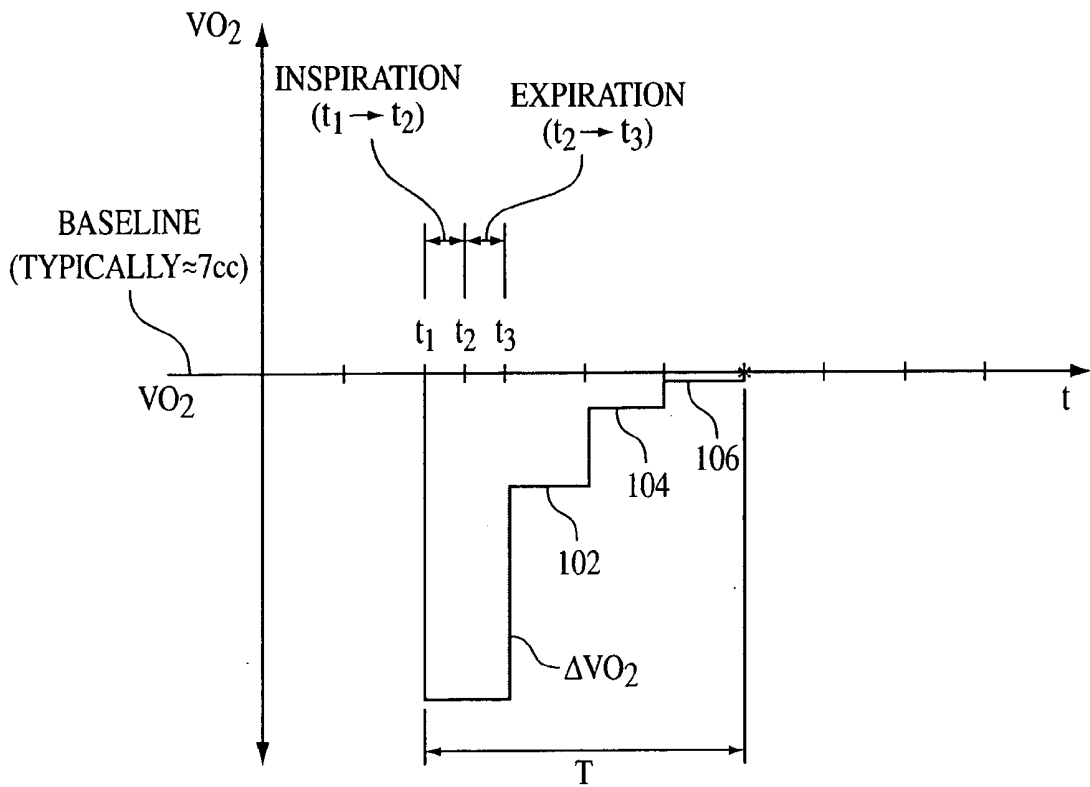

FIG. 3B

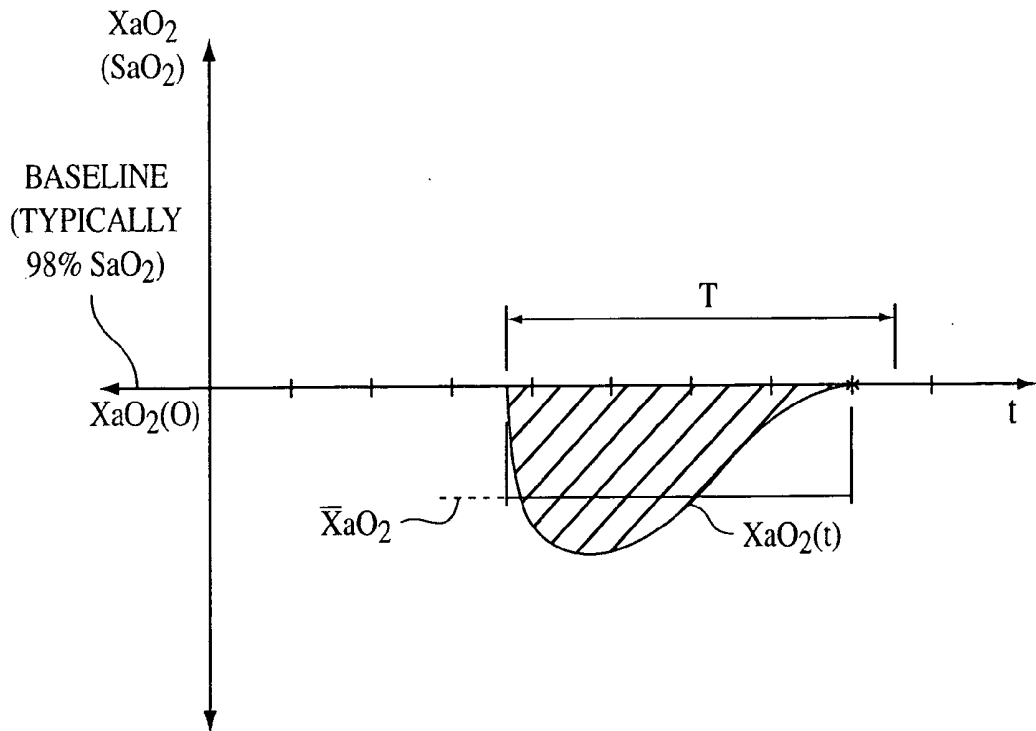

FIG. 4

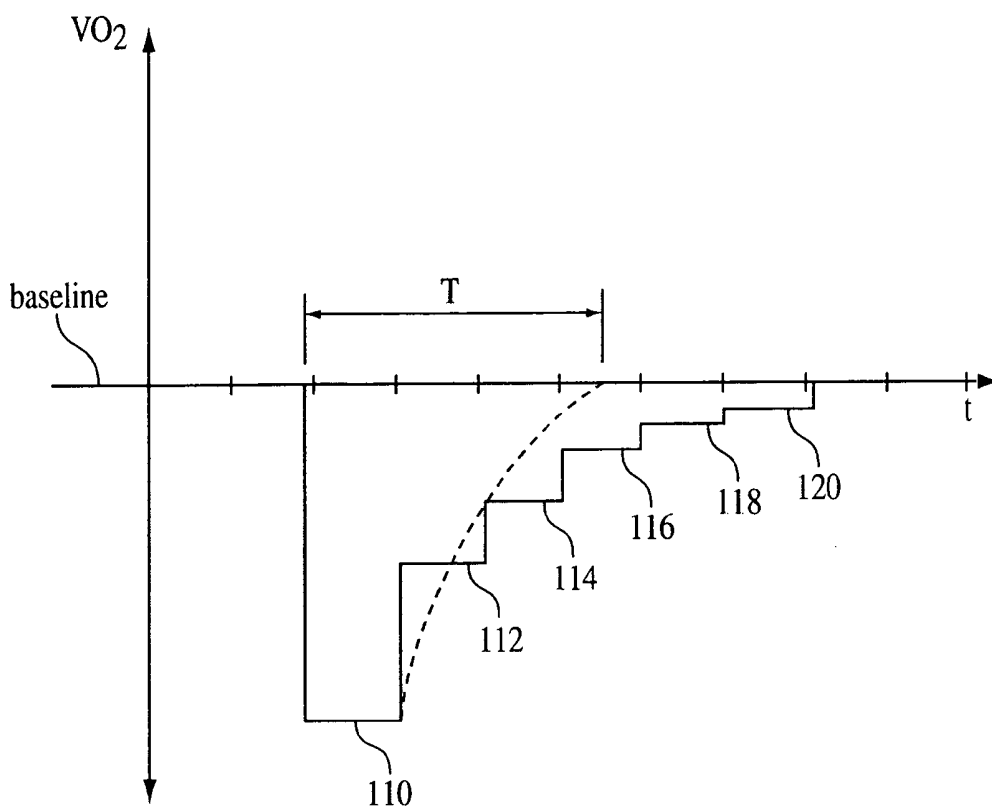

FIG. 5B

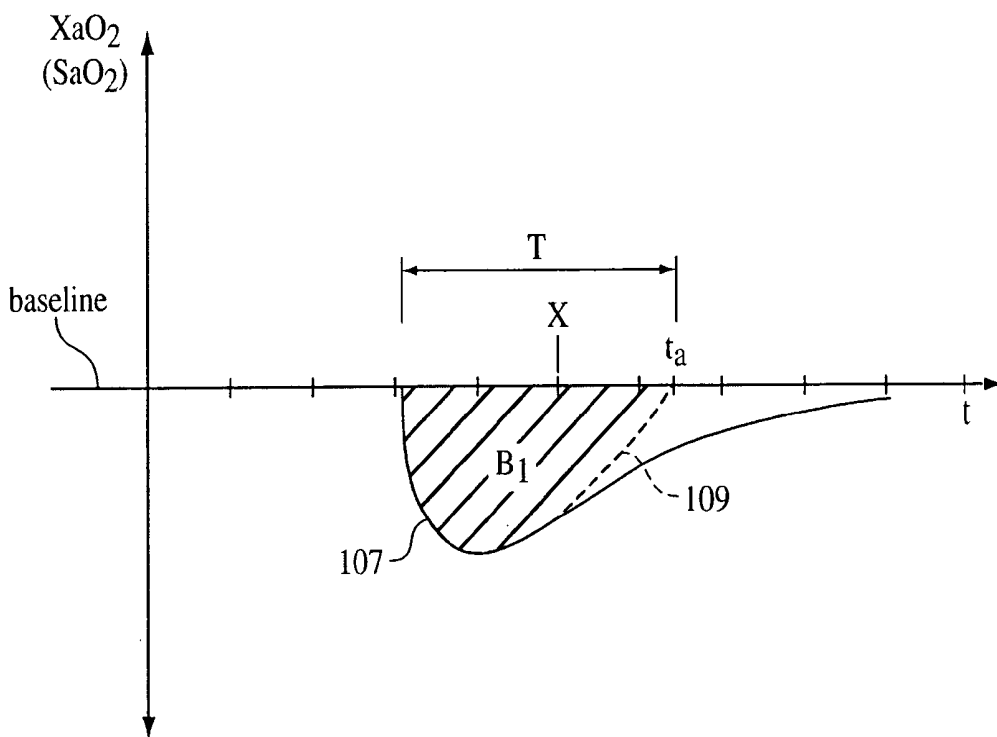

FIG. 6

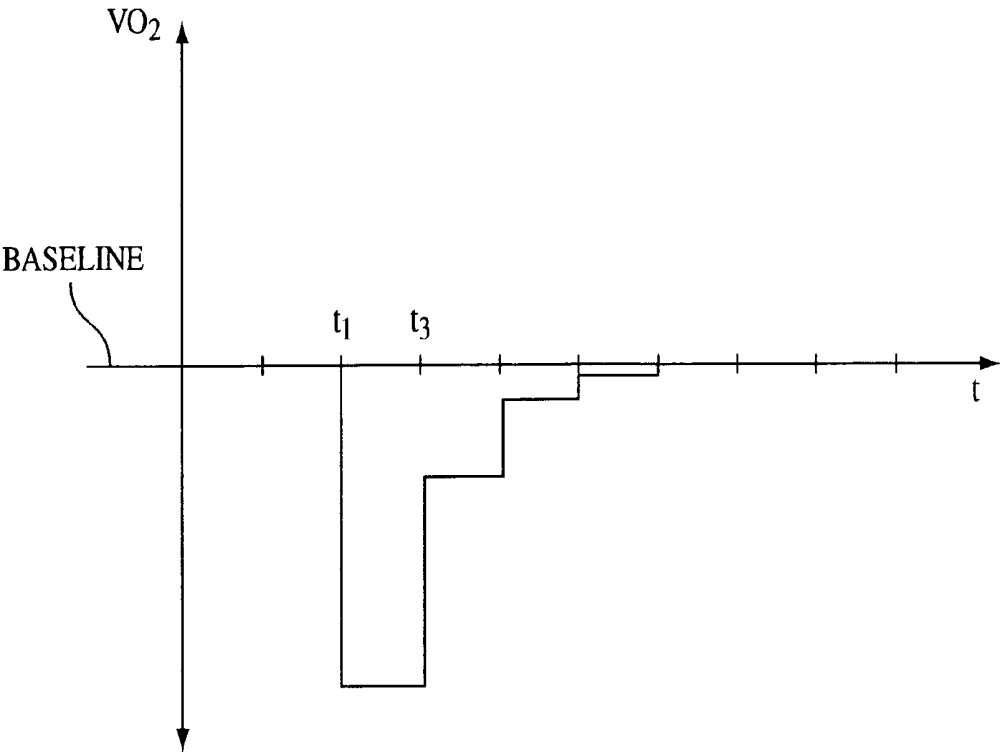

FIG. 7

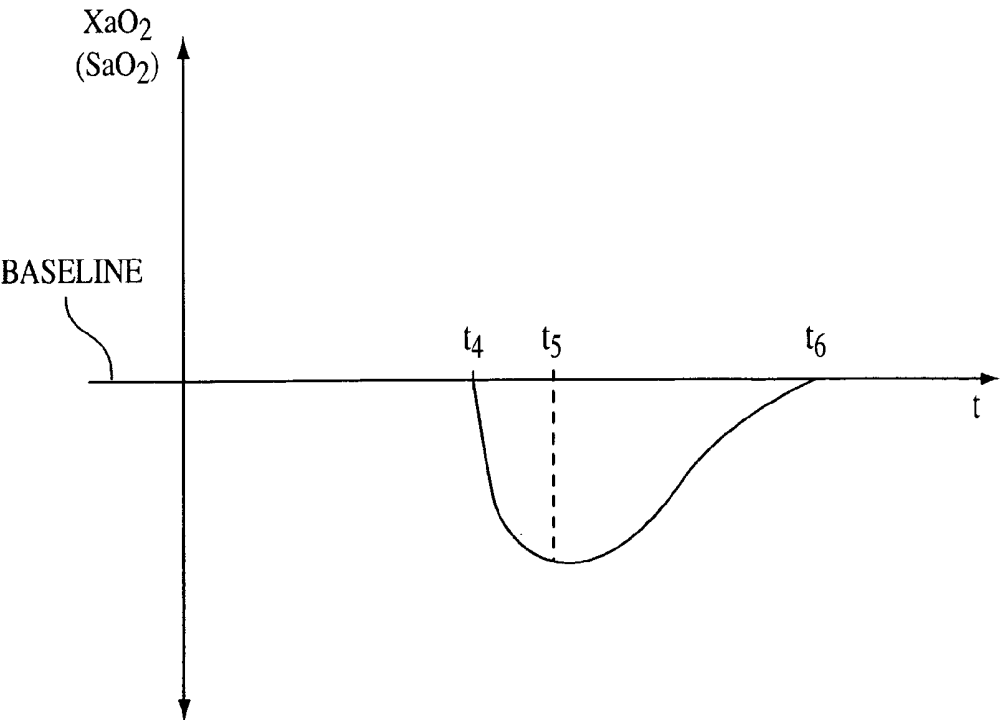

FIG. 8

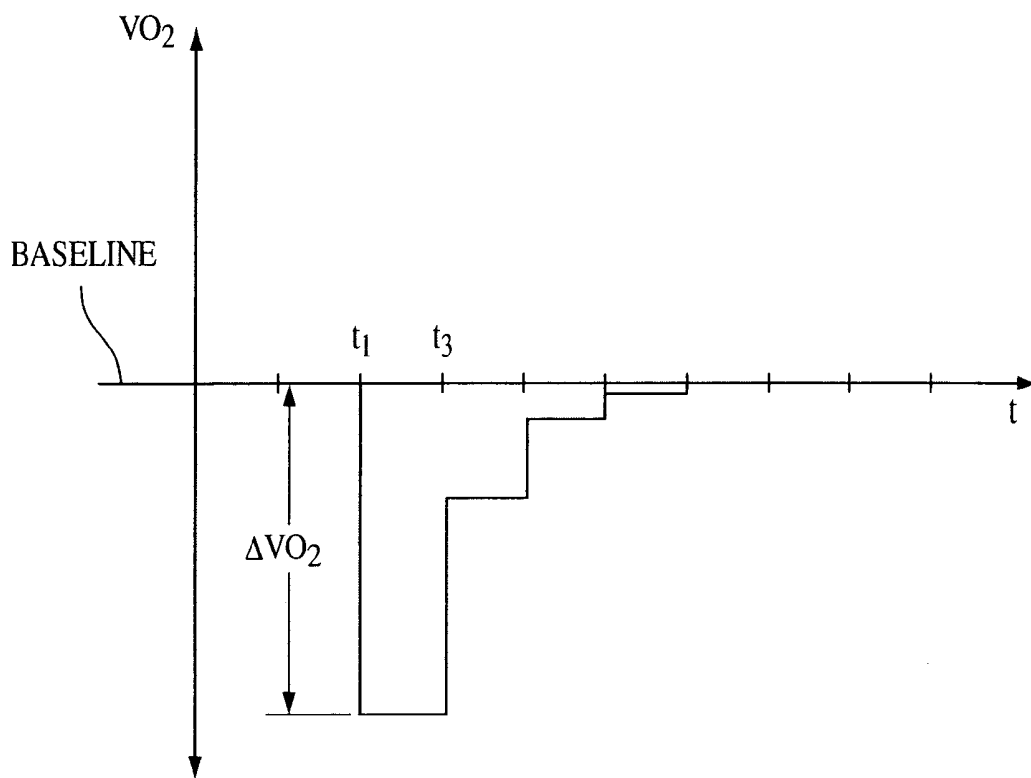

FIG. 9

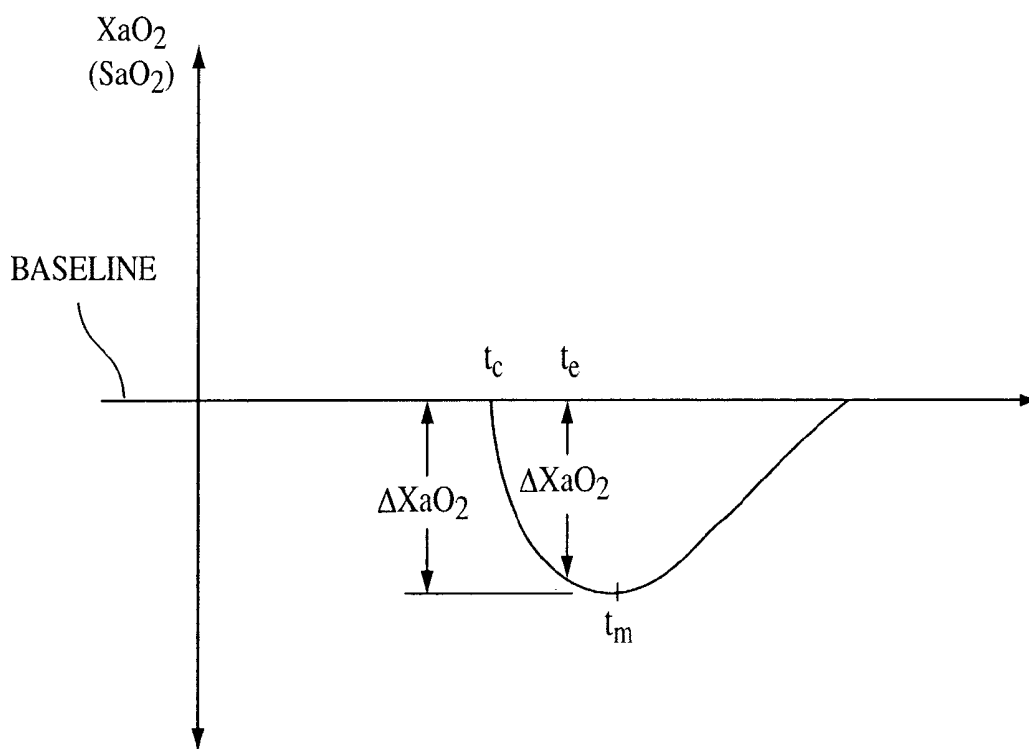

FIG. 10

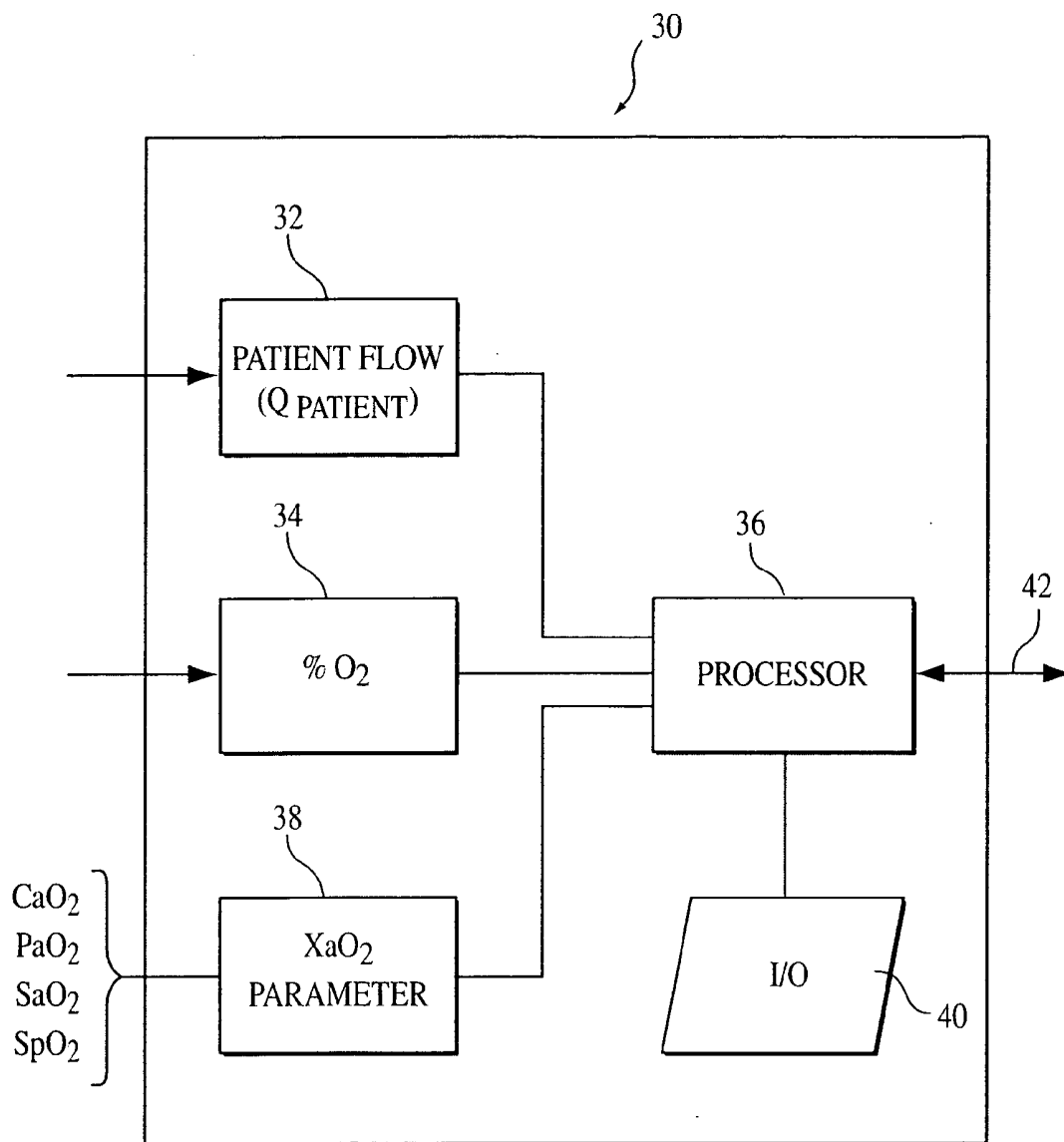

FIG. 11

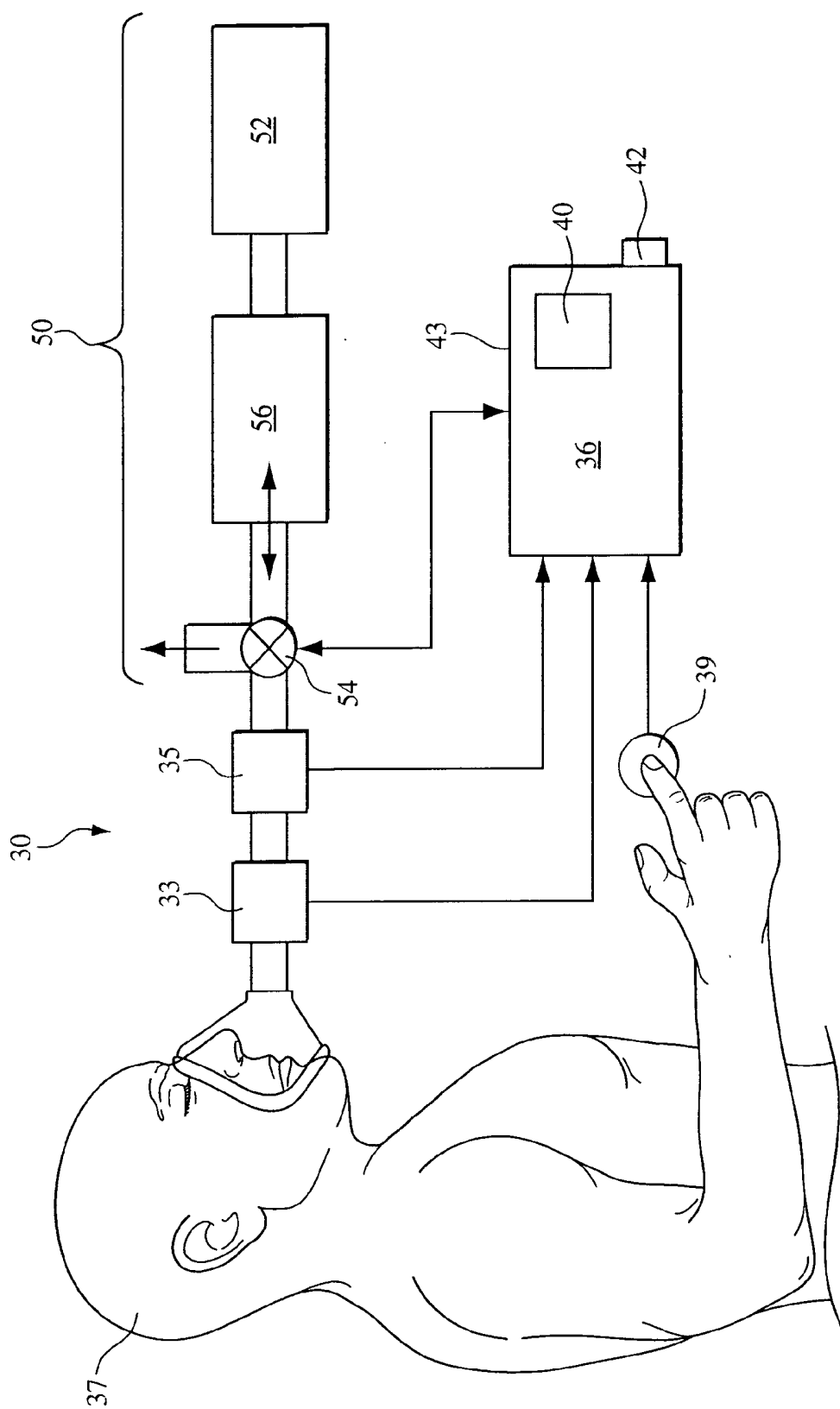

FIG. 12

METHOD AND APPARATUS FOR DETERMINING CARDIAC OUTPUT

BACKGROUND OF THE INVENTION

[0001] 1. Field of the Invention

[0002] The present invention pertains to a method and apparatus for determining the cardiac output of a patient, and, more particularly, to a method of determining cardiac output by analyzing the effect that an induced change in the patient's arterial oxygen concentration has on their oxygen uptake and fractional arterial oxygen concentration, and to an apparatus for use in implementing such a method.

[0003] 2. Description of the Related Art

[0004] There are several generally accepted techniques for measuring cardiac output (CO), which is the total volumetric flow of blood through the heart, and, thus, through the body at any given time. These techniques include: thermodilution, dye dilution, the direct Fick method, and partial CO₂ rebreathing. Thermodilution involves injecting cold saline directly into the right atrium of the heart and measuring the temperature change downstream in the pulmonary artery using a temperature sensor placed in this artery. Cardiac output is determined based on this temperature change. Dye dilution is similar to thermodilution except that a dye, rather than cold saline, is injected into the art. The amount of dye collected downstream is measured to determine the patient's cardiac output.

[0005] According to the direct Fick method, either the content of oxygen (O₂) or the content of carbon dioxide (CO₂) in both the arterial blood and mixed venous blood are measured. The Fick equation, written for oxygen, is: $CO = O_2 \text{ uptake} / (\text{the content of } O_2 \text{ in arterial blood} - \text{the content of } O_2 \text{ in mixed venous blood})$. The Fick equation, written for carbon dioxide, is: $CO = CO_2 \text{ excreted} / (\text{the content of } CO_2 \text{ in mixed venous blood} - \text{the content of } CO_2 \text{ in arterial blood})$. As noted above, the direct Fick method requires obtaining a mixed venous blood sample, which is only available in the pulmonary artery. See FIG. 1.

[0006] It can thus be appreciated that thermodilution, dye dilution, and the direct Fick method for determining cardiac output all require insertion of a catheter into the patient at, near, or through the heart. More specifically, in implementing these cardiac output measurements, a catheter is usually floated through the chambers of the heart in order to insert the saline or dye or to obtain the necessary blood sample at the correct location. For this reason, either of the above cardiac output measurement techniques is very invasive. Indeed, it is known that an arrhythmia may result from the placement of the catheter in or through the heart. Therefore, these cardiac output measurement techniques are typically only performed in the most critical of situations, where the need to know the patient's cardiac output outweighs the risk to the patient in taking this measurement.

[0007] The partial CO₂ rebreathing technique for measuring cardiac output, on the other hand, is a noninvasive approach believed to have been developed by Novamatrix Medical Systems, Inc. of Wallingford, Conn. (Novamatrix). This method is implemented using a device referred to as a NICO™ sensor, which is distributed by Novamatrix. The NICO sensor measures the flow of gas to and from the patient and the CO₂ content in the patient's exhaled gas.

[0008] The partial CO₂ rebreathing cardiac output measurement technique is based on the CO₂ Fick equation in conjunction with what is called partial CO₂ rebreathing. According to this partial CO₂ rebreathing technique, cardiac output is measured by comparing the patient's CO₂ excretion to the arterial CO₂ content during normal breathing and during rebreathing, in which the patient rebreathes expired gases for a period of time. Cardiac output is determined as: $CO = \text{the change in } CO_2 \text{ excretion} / \text{the change in the arterial } CO_2 \text{ content}$.

[0009] Arterial CO₂ is typically determined from a sample of arterial blood. However, in order to eliminate the need for a blood sample to measure the arterial CO₂ content, the partial CO₂ rebreathing technique substitutes end tidal CO₂ (ETCO₂) for the required arterial CO₂ measurement. Therefore, the cardiac output equation becomes: $CO = \text{the change in } CO_2 \text{ excretion} / \text{the change in the } ETCO_2$.

[0010] This partial CO₂ rebreathing technique, however, has several disadvantages. Namely, the patient is preferably intubated or breathing through a trachea tube when taking the flow and CO₂ measurements to capture the total volume of CO₂. In addition, the patient must be heavily sedated or unconscious so that he or she is not breathing spontaneously. If the patient is breathing spontaneously, the increased CO₂ level in the blood during the rebreathing phase would automatically trigger the patient's respiratory system to speed up or deepen the breaths to remove the excess CO₂. It is well known that for most patient's the level of CO₂, not the level of O₂, is the mechanism for triggering ventilation. Such rapid or deep breathing prevents an accurate determination of cardiac output under this technique. It should also be noted that the use of end tidal CO₂, as opposed to the arterial CO₂ content, may introduce errors in determining cardiac output, because there are situations where the end tidal CO₂ may not correlate with the arterial CO₂ content. The partial CO₂ rebreathing cardiac output measurement technique is also disadvantageous because it does not adequately account for shunt blood flow, which is blood that is not oxygenated during the respiratory cycle. This flow cannot be directly measured, but must be estimated when using this conventional cardiac output measurement technique.

SUMMARY OF THE INVENTION

[0011] Accordingly, it is an object of the present invention to provide a method of measuring cardiac output that overcomes the shortcomings of conventional cardiac output measurement techniques. This object is achieved according to one embodiment of the present invention by providing a cardiac output measurement method that includes quantitatively measuring a patient's airflow, a first parameter indicative of a percent oxygen inhaled and exhaled by the patient, and a second parameter indicative of the patient's fractional arterial oxygen concentration. The present method also includes inducing a change in the patient's arterial oxygen concentration and repeating these measurements to monitor the effects resulting from inducing the change in the patient's arterial oxygen concentration. The patient's cardiac output is determined based on the data collected.

[0012] It is yet another object of the present invention to provide an apparatus for non-invasively determining the cardiac output of a patient, including a spontaneously breathing patient, that does not suffer from the disadvantages

associated with conventional cardiac measurement systems. This object is achieved by providing an apparatus that includes a patient flow measuring system capable of quantitatively measuring a patient's airflow, i.e., the flow of gas to and from a patient, an oxygen analyzing system adapted to measure a first parameter indicative of a percent oxygen inhaled and exhaled by such a patient, and means for measuring a second parameter indicative of the patient's fractional arterial oxygen concentration, such as a pulse oximeter. A processor determines the cardiac output based on the measured patient airflow, the first parameter, and the second parameter. In addition, an output device outputs the result indicative of the patient's cardiac output.

[0013] These and other objects, features and characteristics of the present invention, as well as the methods of operation and functions of the related elements of structure and the combination of parts and economies of manufacture, will become more apparent upon consideration of the following description and the appended claims with reference to the accompanying drawings, all of which form a part of this specification, wherein like reference numerals designate corresponding parts in the various figures. It is to be expressly understood, however, that the drawings are for the purpose of illustration and description only and are not intended as a definition of the limits of the invention.

BRIEF DESCRIPTION OF THE DRAWINGS

[0014] FIG. 1 is a schematic diagram of mammalian cardio-pulmonary system;

[0015] FIG. 2 is an oxygen-hemoglobin dissociation curve for a human;

[0016] FIG. 3 is a graph illustrating the change in oxygen uptake that takes place during an induced change in arterial oxygen concentration according to the cardiac output measurement method of the present invention;

[0017] FIG. 4 is a graph illustrating the change in arterial oxygen saturation resulting from the induced change in arterial oxygen concentration;

[0018] FIGS. 5 and 6 are graphs illustrating the change in oxygen uptake and arterial oxygen concentration, respectively, resulting from the induced change in arterial oxygen concentration including the potential effects of recirculation;

[0019] FIGS. 7 and 8 are graphs illustrating the change in oxygen uptake and arterial oxygen concentration, respectively, resulting from the induced change in arterial oxygen concentration illustrating an alternative embodiment for determining cardiac output based on these changes;

[0020] FIGS. 9 and 10 are graphs illustrating the change in oxygen uptake and arterial oxygen concentration, respectively, resulting from the induced change in arterial oxygen concentration illustrating yet another alternative embodiment for determining cardiac output based on these changes;

[0021] FIG. 11 is a schematic diagram of a device for implementing the cardiac output measurement method of the present invention; and

[0022] FIG. 12 is a schematic diagram of the device of FIG. 11 shown in use on a patient.

DETAILED DESCRIPTION OF THE PRESENTLY PREFERRED EMBODIMENTS OF THE INVENTION

[0023] FIG. 1 schematically illustrates a patient's cardiopulmonary system, which is useful in understanding the cardiac output measurement system of the present invention. The cardiac output measurement technique of the present invention measures the output, i.e., rate of flow of blood, from the left side of the heart. As described in detail below, the cardiac output measurement method of the present invention uses the transfer of oxygen from the lungs to the arteries in order to determine cardiac output.

[0024] The presently preferred method of determining the cardiac output includes the following steps, each of which is discussed in detail below:

[0025] (1) quantitatively measuring (a) the patient's airflow, (b) a parameter indicative of the percent oxygen inhaled and exhaled by the patient, and (c) a parameter indicative of the patient's fractional arterial oxygen concentration (X_{aO_2});

[0026] (2) inducing a change in the patient's arterial oxygen concentration while taking measurements (a)-(c) set forth in step (1) to monitor the effects of the change in the patient's arterial oxygen concentration; and

[0027] (3) from the data collected regarding the effect of the change in the patient's arterial oxygen concentration, determining the patient's cardiac output.

[0028] According to the present invention, the patient's cardiac output (CO) is determined based on the change in oxygen uptake versus the change in fractional arterial oxygen concentration resulting from the induced change in the arterial oxygen concentration. Stated another way:

$$CO = \frac{\text{change in the oxygen uptake}}{\text{change in the arterial oxygen concentration}} \quad (1)$$

[0029] It is important to note that the patient's arterial oxygen concentration, not their carbon dioxide concentration, is what is being manipulated in order to induce a change in the patient's oxygen uptake and fractional arterial oxygen concentration. As a result, this method can be performed on a spontaneously breathing patient, as well as a patient who is not spontaneously breathing. Unlike changing the patient's CO_2 concentration, changing the patient's arterial O_2 concentration will not cause the patient to automatically attempt to alter their breathing pattern to move the O_2 concentration back to normal. Because this cardiac output measurement technique involves inducing a change in the patient's arterial oxygen concentration, it is referred to as an oxygen concentration modification cardiac output measurement method.

[0030] In one embodiment of the present invention, which is described in detail below, the patient's fractional arterial oxygen concentration is measured non-invasively using a conventional pulse oximeter. Thus, unlike conventional cardiac output measurement methods, the oxygen concentration modification cardiac output measurement method of the

present invention can be performed non-invasively on a spontaneously breathing patient.

[0031] I. Measuring Airflow, Percent O₂ Inhaled/Exhaled, and the Fractional Arterial Oxygen Concentration

[0032] According to the present invention, the patient's quantitative airflow and a parameter indicative of the percent oxygen inhaled and exhaled by the patient are measured to determine the patient's oxygen uptake. Oxygen uptake is the amount of oxygen absorbed into the blood in the lungs. It is typically expressed in liters as VO₂ or in liters per minute (lpm) as $\dot{V}O_2$. Thus, equation (1) can be rewritten as follows:

$$CO \text{ (liters)} = \frac{\Delta VO_2}{\Delta XaO_2}, \text{ or as} \quad (2)$$

$$CO \text{ (lpm)} = \frac{\Delta \dot{V}O_2}{\Delta XaO_2}. \quad (3)$$

[0033] Oxygen uptake, which is measured during a breathing cycle, is determined by measuring the volumetric airflow Q_{patient} to and from the patient, the % O₂ inhaled, and the % O₂ exhaled during that breathing cycle. Volumetric airflow is measured using a flow meter, such as a conventional pneumotach, that is capable of quantitatively measuring the flow of gas to and from the patient's airway. U.S. Pat. No. 6,017,315 to Starr et al., the contents of which are incorporated herein by reference, describes a suitable flow meter that quantitatively measures the flow of gas to and from a patient.

[0034] The % O₂ inhaled and % O₂ exhaled is measured using a conventional oxygen analyzer. An example of a combination flow sensing element and O₂ concentration analyzer window suitable for use in the present invention is taught in provisional U.S. Patent Application No. 60/170,918, the contents of which are incorporated herein by reference. More specifically, the present invention contemplates determining the % O₂ inhaled by measuring the patient's fraction of inspired oxygen (FIO₂) as a parameter indicative of the percent oxygen inhaled and exhaled, and multiplying this FIO₂ by 100, i.e., % O₂ inhaled=FIO₂(inhaled)*100. A similar process is used to determine % O₂ exhaled.

[0035] Oxygen uptake, VO₂, for one breath, is determined as follows:

$$VO_2 \text{ inhaled} = \int_{t_1}^{t_2} (Q_{\text{patient}}[\%O_2 / 100])dt, \quad (4)$$

$$VO_2 \text{ exhaled} = \int_{t_2}^{t_3} (Q_{\text{patient}}[\%O_2 / 100])dt, \text{ and} \quad (5)$$

$$VO_2 = VO_2 \text{ inhaled} - VO_2 \text{ exhaled}, \quad (6)$$

[0036] where t_1 is the start of inhalation, t_2 is the end of inhalation or start of exhalation, and t_3 is the end of exhalation. Oxygen uptake in liters per minute is then determined as:

$$\dot{V}O_2 = VO_2 * f_{\text{breath}}, \quad (7)$$

[0037] where f_{breath} is the frequency of breaths, i.e., breaths per minute.

[0038] There are a variety of parameters indicative of fractional arterial oxygen concentration, XaO₂, of a patient that can be measured and used in the cardiac output determination method. One embodiment of the present invention contemplates measuring at least one the following blood gas constituents, SaO₂, PaO₂, and CaO₂ as the parameter indicative of the patient's fractional arterial oxygen concentration XaO₂. These parameters are measured from an arterial blood sample or using a continuously indwelling catheter. It is preferable for one or more of these constituents to be measured continuously, for example, using an indwelling catheter so that the effects of the induced change in arterial oxygen concentration on the oxygen uptake and fractional arterial oxygen concentration can be monitored on a substantially continuous basis. This is especially important because of the relatively short duration of the effects of the induced change in arterial oxygen concentration resulting from the oxygen concentration modification step.

[0039] The present invention also contemplates measuring the pulse oximetry oxygen saturation level (SpO₂) of the patient as the parameter indicative of the fractional arterial oxygen concentration XaO₂. This measurement is advantageous in that the SpO₂ can be measured non-invasively using a conventional pulse oximeter. It can also be taken on a generally continuous basis to closely monitor the effects of the induced oxygen concentration modification on the patient's actual fractional arterial oxygen concentration.

[0040] Although the SpO₂ level can be taken from almost any location on the patient, such as the finger or ear, in a preferred embodiment, the SpO₂ is measured across the nasal septum. This location is especially desirable because it represents a relatively direct flow from the carotid artery, as shown in FIG. 1.

[0041] Depending on which parameter, SpO₂, SaO₂, PaO₂, or CaO₂, indicative of fractional arterial oxygen concentration XaO₂ is measured, a conversion may be required in order to arrive at the patient's actual fractional arterial oxygen concentration XaO₂. The only parameter indicative of fractional arterial oxygen concentration XaO₂ that does not have to be converted in order to arrive at the patient's fractional arterial oxygen concentration XaO₂ is the arterial oxygen content measurement CaO₂, because CaO₂ is a direct measurement of the fractional arterial oxygen concentration. Thus, CaO₂=XaO₂, and no conversion is necessary.

[0042] Oxygen saturation, SaO₂, on the other hand, is not a direct measurement of the fractional arterial oxygen concentration XaO₂. If SaO₂ is the measured parameter, a conversion is needed, so that the measured SaO₂ can be used as the fractional arterial oxygen concentration XaO₂. For a normal adult, there is a linear relation between SaO₂ and CaO₂ and, hence, between SaO₂ and XaO₂. More specifically, the following relationship is known:

$$\frac{Vol \% O_2}{(SaO_2)} = \frac{(Hb \text{ concentration})(O_2 \text{ saturation})}{(O_2 \text{ carrying capacity of Hb})}, \quad (8)$$

[0043] where, for a normal adult, the O₂ carrying capacity of hemoglobin (Hb) is approximately 1.34 mlO₂/gmHb, and the Hb concentration is approximately 15 gmHb/100 ml blood. Thus, for a normal adult:

$$X_{aO_2} = \frac{\text{Vol \%O}_2}{100} = \frac{15 \text{ gmHb}}{100 \text{ mlblood}} * \frac{\text{SaO}_2}{100} * \frac{1.34 \text{ mlO}_2}{\text{gmHb}} \quad (9)$$

[0044] Equation (9) can be simplified as:

$$X_{aO_2} = \text{SaO}_2 * k \quad (10)$$

[0045] where, for a normal adult:

$$k = \frac{(15)(1.34)}{(100)(100)} \quad (11)$$

[0046] Of course, the values for Hb concentration (15 gmHb) and O₂ carrying capacity of Hb (1.34 mlO₂) can differ depending on the individual. Therefore, if the Hb concentration and O₂ carrying capacity of Hb for an individual are known, a more exact relationship (k value) between SaO₂ and XaO₂ can be determined. The present invention contemplates that the values for Hb concentration and/or O₂ carrying capacity of Hb can be directly input by the user, automatically input from measurements taken by a co-oximeter or other equivalent device via a communication link with such a device, manually or automatically selected from a range of values based on information about the patient, or a default value can be used.

[0047] There is also a known relationship, albeit nonlinear, between PaO₂ and SaO₂. This nonlinear relationship is graphically depicted in FIG. 2, which is referred to as an oxygen-hemoglobin dissociation curve 10. If PaO₂ is the measured parameter, it must first be converted to an SaO₂ using the dissociation curve, which can be accomplished using any conventional technique. Thereafter, the conversion factor k for SaO₂ must be used to arrive at the patient's fractional arterial oxygen concentration XaO₂ as discussed above.

[0048] A patient's SaO₂, PaO₂, or CaO₂ can only be measured by sampling the patient's arterial blood or using a continuously indwelling catheter, either of which is a relatively invasive procedure. SpO₂, on the other hand, which is an estimation of SaO₂, is measured non-invasively. Therefore, measuring the patient's SpO₂ has the advantage of being fast, easy, and non-invasive. If SpO₂ is taken as the measured parameter, it is considered an approximation of SaO₂, i.e., SpO₂=SaO₂. Thus, the conversion factor k is applied to the measured SpO₂ to arrive at the patient's fractional arterial oxygen concentration XaO₂, i.e., XaO₂=SPO₂*k.

[0049] II. Inducing a Change in Arterial Oxygen Concentration

[0050] The present technique for determining a patient's cardiac output involves inducing a change the patient's arterial oxygen concentration. This can be done in a variety of ways, several of which are discussed below, so long as there is a measurable difference between the patient's baseline arterial oxygen concentration and the patient's arterial oxygen concentration following the induced change therein. Because the goal of this process is to force a change in the patient's arterial oxygen concentration, this step in the

cardiac output measurement process of the present invention is referred to herein as the "oxygen concentration modification step."

[0051] It should be noted that the arterial oxygen concentration can either be increased or decreased depending on the condition of the patient. For example, a generally healthy patient has an oxygen saturation level of approximately 98%. As a result, there is very little room to improve oxygenation, e.g., up to 99%. Therefore, the present invention contemplates reducing the patient's oxygen saturation as one technique for inducing a change in the patient's arterial oxygen concentration, especially in those patients with a relatively high baseline SaO₂.

[0052] Reducing the patient's oxygen saturation can be accomplished by reducing the fraction of inspired oxygen (FIO₂) in the patient's inhaled gas. This can be accomplished, for example, by increasing the concentration of other inhaled gas constituents, such as nitrogen, which as the effect of lowering the patient's arterial oxygen saturation. In one embodiment of the present invention, the patient breathes nitrogen for one or more breaths, thereby reducing their arterial oxygen concentration. This technique is particularly suited for patients with a relatively high baseline oxygen concentration.

[0053] As noted above, changing the patient's arterial oxygen concentration can also be accomplished by increasing the fraction of inspired oxygen in the inhaled gas. This can be accomplished, for example, by adding supplemental oxygen to the patient's inhaled gas, and, therefore, is particularly suited for patients with a relatively low baseline oxygen concentration.

[0054] The present invention also contemplates changing the patient's arterial oxygen concentration by having the patient rebreathe expired gas. However, because this will raise the patient's CO₂ level, this technique is best used on non-spontaneously breathing patients, where increased levels of CO₂ will not cause unusual breathing patterns. For a non-spontaneously breathing patient, the present invention also contemplates changing the arterial oxygen concentration by momentarily pausing the ventilator used to provide the patient's breathing.

[0055] Rebreathing expired gas can be used to change the patient's arterial oxygen concentration in a spontaneously breathing patient if steps are taken to minimize the increase in the patient's CO₂ level. For example, the carbon dioxide CO₂ is preferably removed from the rebreathed gas so that the patient does not dramatically alter their breathing pattern due to rebreathing of exhaled carbon dioxide.

[0056] An exemplary embodiment of the present invention contemplates using a conventional CO₂ "scrubbing" technique for removing the CO₂ from the gas rebreathed by the patient. This is accomplished, for example, by placing a CO₂ scrubber in the rebreathing circuit or by passing the patient's exhaled gas through a CO₂ scrubber before it is returned to the patient. In either case, the rebreathed gas will have a lower oxygen concentration, thereby accomplishing the goal of changing the patient's arterial oxygen concentration without having the patient breathing CO₂, which will likely trigger a relatively rapid increase in the patient's breath rate.

[0057] III. Determining Cardiac Output

[0058] The present invention contemplates several techniques for calculating cardiac output based on the changes in oxygen uptake and the change in fractional arterial oxygen concentration resulting from the induced change in arterial oxygen concentration. Each of these techniques is discussed in turn below.

[0059] A. Technique 1—Calculating Cardiac Output Based on the Area Under the Curves

[0060] It is well known that the rate of flow (Q) of a fluid, which is typically expressed in liters per minute (lpm), is defined as:

$$Q = \frac{V}{t}, \tag{12}$$

[0061] where V is volume and t is time. For a given period of time, t_a to t_b , the rate of flow of fluid during that period is determined as follows:

$$Q = \frac{V}{t_b - t_a} \tag{13}$$

[0062] The following relationships are also known:

$$XaO_2 = \frac{VO_2}{V}, \text{ or} \tag{14}$$

$$V = \frac{VO_2}{XaO_2}. \tag{15}$$

[0063] Substituting equation (14) into equation (13) yields:

$$Q = \frac{VO_2}{XaO_2 * (t_b - t_a)}. \tag{16}$$

[0064] Equation (16), however, cannot be used to determine a patient's cardiac output because it does not take into consideration the fact that in the pulmonary system, the venus blood contains a predetermined level of oxygen before it is oxygenated in the lungs. In addition, this equation does not take into consideration blood that is shunted across the lungs and does not get oxygenated during a breathing cycle.

[0065] The present invention takes these items into consideration and accounts for their effect by, in essence, determining the baseline oxygen concentration and oxygen uptake for the patient, then executing the oxygen concentration modification step, in which the patient's fractional arterial oxygen concentration is changed from the baseline value. The present invention determines cardiac output by monitoring the arterial oxygen concentration and oxygen uptake during this oxygen concentration modification step

and by comparing the changes in the arterial oxygen concentration and oxygen uptake to the baseline levels.

[0066] FIG. 3 is a graph that illustrates the change in a patient's oxygen uptake, VO_2 , that takes place during the oxygen concentration modification step, in which a change in the arterial oxygen concentration, XaO_2 , is induced using any of the above-described techniques. More specifically, FIG. 3 illustrates the change in oxygen uptake that takes place by having the patient take one breath, i.e., from time t_1 to t_3 , that is relatively devoid of oxygen. It should be noted that the change in oxygen uptake is illustrated in a step fashion because oxygen uptake is measured and calculated on a breath-by-breath basis. As shown in FIG. 3, it takes several breaths for the patient's oxygen uptake to stabilize back to its baseline level. Area A in FIG. 3 represents the change in the oxygen uptake ΔVO_2 of the patient that occurs as a result of oxygen concentration modification step.

[0067] FIG. 4 illustrates the change in arterial oxygen saturation SaO_2 resulting from the induced change in arterial oxygen concentration, which, in this embodiment, involves having the patient take one breath that is devoid of oxygen. Area B in FIG. 4 represents the change in arterial oxygen concentration ΔXaO_2 that occurs as a result of oxygen concentration modification step. These changes are measured and used to calculate cardiac output as follows:

$$Q = \frac{\Delta VO_2}{\Delta XaO_2 * (t_b - t_a)}, \tag{17}$$

[0068] where:

$$\Delta VO_2 = VO_2 \text{ baseline} - VO_2 \text{ after oxygen concentration modification} \tag{18}$$

$$\Delta XaO_2 = XaO_2 \text{ baseline} - XaO_2 \text{ after oxygen concentration modification} \tag{19}$$

[0069] It can be appreciated from FIGS. 3 and 4 that although the patient takes only one breath that is devoid of oxygen, the patient's oxygen uptake will shift from its baseline level for several breaths. i.e., from time t_a to time t_b . Therefore, the present invention contemplates summing the oxygen uptake that occurs for each breath over the entire time, t_a to t_b , that the oxygen uptake is shifted from baseline, which, in effect, amounts to determining the area A under the curve, which is why this technique is referred to in the section heading as "Calculating Cardiac Output Based on the Area Under the Curves."

[0070] The patient's arterial oxygen concentration will also shift from its baseline level for a period of time t_c to t_d . Therefore, the present invention contemplates finding the average arterial oxygen concentration resulting from the oxygen concentration modification step. It should be noted that the change in arterial oxygen concentration does not coincide with the start of the oxygen concentration modification step, i.e., $t_c \neq t_a$, because it takes some time for the change in inspired oxygen level to affect the patient's arterial oxygen concentration. Thus, equation (19) for the present invention is rewritten as:

$$Q = \frac{\sum \Delta VO_2}{\Delta \bar{X} aO_2 * (t_b - t_a)} \quad (20)$$

[0071] Equation (20) can be written in greater detail as:

$$Q = \frac{\sum (VO_2 \text{ baseline} - VO_2 \text{ after oxygen concentration modification})_{t_b - t_a}}{\int_{t_c}^{t_d} \left[\frac{Sp O_2 \text{ baseline} - Sp O_2 \text{ after oxygen concentration modification}}{(t_d - t_c)} \right] dt * (t_b - t_a)} \quad (21)$$

[0072] where:

$$VO_2 = \int_{t_1}^{t_2} (Q_{\text{patient}} [\% O_2 / 100]) dt - \int_{t_2}^{t_3} (Q_{\text{patient}} [\% O_2 / 100]) dt \quad (22)$$

[0073] FIGS. 5 and 6 are similar to FIGS. 3 and 4, respectively, except that FIGS. 5 and 6 take into consideration a scenario in which the patient's blood begins to recirculate at time x during the oxygen concentration modification step. It can be appreciated from FIG. 5, that the patient's oxygen uptake may increase above baseline and then eventually return to its baseline level at time t_{b1} . In this situation, the only area of interest is the area under the baseline, i.e., area A_1 . That is, the effects of recirculation, and, hence, area A_2 should be ignored in solving equation (21). For this reason, the present invention contemplates extrapolating to determine the baseline crossing point, which corresponds to point t_b in equation (21). Thus, the change in oxygen uptake resulting from the oxygen concentration modification step, in this situation, will take into consideration the sum of areas A_1 and A_2 for purpose of solving equation (21), ignoring area A_3 above the baseline.

[0074] FIG. 6 illustrates that a second drop in the patient's arterial oxygen saturation will occur at time x due to the recirculation of the relatively oxygen poor blood. If this second drop, which is represented by area B_2 , is minimal, it can be ignored for purposes of determining the time period t_c to t_d . Thus, the time period t_c to t_{d2} associated with areas B_1 and B_2 are used to solve equation (21).

[0075] However, if this second drop is not minimal, the time period t_c to t_{d1} associated with area B_1 alone is used for solving equation (21). The location of time t_{d1} is determined using any conventional extrapolation technique. Of course, the present invention contemplates using suitable programming or other means for deciding when the effect of recirculation, and, hence the size of area B_2 is above the predetermined minimal threshold and must be accounted for in solving equation (21).

[0076] B. Technique 2—Calculating Cardiac Output Based on the Slopes of the Curves

[0077] FIGS. 7 and 8, like FIGS. 3 and 4, illustrate the changes in the patient's oxygen uptake and arterial oxygen

saturation, respectively, resulting from the oxygen concentration modification step. From FIG. 7, it can be appreciated that the change in oxygen uptake that takes place during the first breath of the oxygen concentration modification step can be defined in terms of its slope as:

$$\Delta VO_2 = \frac{\Delta y}{\Delta x} = \frac{y_2 - y_1}{x_2 - x_1} = \frac{VO_2(t_3) - VO_2(t_1)}{t_3 - t_1} \quad (23)$$

[0078] recall from above that t_i corresponds to the start of inspiration and that t_3 corresponds to the end of expiration, and where $VO_2(t_1)$ and $VO_2(t_3)$ are the oxygen uptakes at times t_1 and t_3 , respectively. It can be further appreciated that equation (23) defines the slope of dashed line C in FIG. 7.

[0079] From FIG. 8, it can be appreciated that the change in fractional arterial oxygen concentration that takes place during the same time period $t_3 - t_1$ can also be defined in terms of its slope as:

$$\Delta XaO_2 = \frac{XaO_2(t_5) - XaO_2(t_4)}{t_5 - t_4} \quad (24)$$

[0080] where, $t_5 - t_4 = t_3 - t_1$, and where $XaO_2(t_5)$ and $XaO_2(t_4)$ are the arterial oxygen concentration at times t_5 and t_4 , respectively. It can be further appreciated that equation (24) defines the slope of dashed line D in FIG. 8. Therefore, this cardiac output determination technique is referred to in the immediately preceding section heading as the "Slopes of the Curve" technique. From equation (15) it is known that:

$$\Delta V = \frac{\Delta VO_2}{\Delta XaO_2} \quad (25)$$

[0081] Substituting equations (23) and (24) in to equation (25) yields:

$$\Delta V = \left[\frac{VO_2(t_3) - VO_2(t_1)}{t_3 - t_1} \right] \left[\frac{t_5 - t_4}{XaO_2(t_5) - XaO_2(t_4)} \right] \quad (26)$$

[0082] From equations (13) and (26), the patient's cardiac output Q in liters per minute is defined as:

$$Q = \frac{\Delta V}{t_3 - t_1} = \left[\frac{VO_2(t_3) - VO_2(t_1)}{(t_3 - t_1)^2} \right] \left[\frac{t_5 - t_4}{XaO_2(t_5) - XaO_2(t_4)} \right] \quad (27)$$

[0083] It can be appreciated that determining cardiac output based on the slopes of lines C and D is advantageous in that the effects of recirculation, if any, do not influence the determination of cardiac output.

[0084] C. Technique 3—Calculating Cardiac Output Based on the Magnitude of the Curves

[0085] Yet another technique for determining cardiac output involves comparing the magnitude of the change in oxygen uptake with the magnitude of the change in arterial oxygen concentration resulting from the oxygen concentration modification step. FIGS. 9 and 10 illustrate the changes in the patient's oxygen uptake and arterial oxygen saturation, respectively, resulting from the oxygen concentration modification step. From FIG. 9, it can be appreciated that there is a relatively large initial drop in oxygen uptake at the start of the oxygen concentration modification step, i.e., from time t_1 to t_3 . The magnitude of this drop can be determined from the output of the flow sensor and the oxygen analyzer using any conventional technique. From FIG. 10, it can be appreciated that there is corresponding drop in arterial oxygen saturation. Although, as noted above, this drop in arterial oxygen concentration is delayed in time from the initial drop in oxygen uptake. This drop begins at time t_c and reaches a maximum difference from the initial baseline level at time t_m . The value of the fractional arterial oxygen concentration at t_m , $XaO_2(t_m)$, can be determined using any conventional technique.

[0086] As a side note, it is worth remembering that the oxygen concentration modification step also contemplates increasing the patient's arterial oxygen in some situations. In which case, the change in oxygen uptake will be in the positive direction, opposite that shown in FIGS. 3, 5, 7, and 9. Similarly, the change in the fractional arterial oxygen concentration will also be in the positive direction, opposite that shown in FIGS. 4, 6, 8, and 10. The techniques for determining cardiac output discussed herein are equally applicable where the oxygen concentration modification step is performed by increasing the patient's arterial oxygen.

[0087] Referring again to FIGS. 9 and 10, one embodiment of the present invention contemplates comparing the magnitude of the change in oxygen uptake from time t_1 to t_3 with the magnitude of the change in arterial oxygen concentration from time t_c to t_m , so that the patient's cardiac output is defined as:

$$CO = \frac{\Delta V O_2(\text{Magnitude } t_1 \text{ to } t_3)}{X a O_2(\text{Magnitude } t_c \text{ to } t_m)} = \frac{\Delta \dot{V} O_2(\text{Magnitude } t_1 \text{ to } t_3)}{\Delta X a O_2(\text{Magnitude } t_c \text{ to } t_m)} \quad (28)$$

[0088] It can be appreciated that equation (28) represents a direct calculation for cardiac output because the units represented by the numerator are, for example, liters/second or liters/minute, and the denominator is unitless.

[0089] Another embodiment of the present invention contemplates determining cardiac output based on the time period t_c to t_e , where $t_c = t_1$ to t_3 , so that

$$CO = \frac{\Delta V O_2(\text{Magnitude } t_1 \text{ to } t_3)}{\Delta X a O_2(\text{Magnitude } t_c \text{ to } t_e)} = \frac{\Delta \dot{V} O_2(\text{Magnitude } t_1 \text{ to } t_3)}{\Delta X a O_2(\text{Magnitude } t_c \text{ to } t_e)} \quad (29)$$

[0090] As with equation (28), equation (29) also represents a direct calculation for cardiac output because the unit represented by the numerator are, for example, liters/second or liters/minute, and the denominator is unitless. In these embodiments, the change in magnitude of the oxygen uptake and fractional arterial oxygen concentration are monitored during the oxygen modification step, which is why this technique is referred to in the preceding section heading as the "Magnitude of the Curve" technique.

[0091] D. Technique 4—Calculating Cardiac Output Based on the Volume of Blood Flow

[0092] It is known that the volume of blood flowing through the heart during a breathing cycle is defined as:

$$V_{blood} = \int_{t_1}^{t_3} \frac{\Delta \dot{V} O_2}{\Delta X a O_2} dt \quad (30)$$

[0093] and the flow of blood, i.e., cardiac output, in liters per minute, for example, it defined as:

$$Q_{blood} = \frac{V_{blood}}{t} \quad (31)$$

[0094] It can be appreciated that equation (30) can be substituted into equation (31) to determine the cardiac output.

[0095] One embodiment of the present invention contemplates determining the baseline oxygen uptake and baseline arterial oxygen concentration before performing the oxygen concentration modification step so that the changes in oxygen uptake and baseline arterial oxygen concentration resulting from the oxygen concentration modification step can be compared to this baseline. It is to be understood, however, that in an alternative embodiment of the present invention, the baseline oxygen uptake and baseline arterial oxygen concentration are established after the effects of the oxygen concentration modification step; namely, after the patient's cardio-pulmonary system has returned to a steady state following the oxygen concentration modification step.

[0096] FIGS. 11 and 12 schematically illustrate an exemplary embodiment of a cardiac output measurement device 30 used to implement the above-described cardiac output measurement method. Cardiac output measurement device 30 includes a patient flow measurement system 32 for quantitatively measuring the flow of gas to and from the patient and an oxygen analyzer 34 that measures the patient's fraction of inspired oxygen (FIO_2). Patient flow measurement system 32 includes a flow sensor 33, also

referred to as a flow element, that creates a pressure differential for measuring the flow of gas passing through the flow element Oxygen analyzer **34** includes an oxygen analyzing element **35**, which is essentially an airway adapter optical window and an O₂ transducer having phototransmitter and photodetector, that is used to measure the amount of oxygen passing in front of the optical window. Flow sensor **33** and oxygen analyzing element **35** are preferably located proximate to the patient's airway. The outputs of the patient flow and oxygen analyzing systems are provided to a microprocessor **36** for calculating the patient's oxygen uptake.

[0097] Cardiac output measurement device **30** includes means **38** for detecting a parameter indicative of the fractional arterial oxygen concentration, XaO₂, of a patient. As noted above, this parameter is any one of either SpO₂, SaO₂, PaO₂, or CaO₂. An example of a sensor that measures SpO₂ is a conventional pulse oximeter, and a sensor that measures SaO₂, PaO₂, or CaO₂ is a continuous indwelling catheter. Depending on the parameter measured, a conversion to XaO₂ may be necessary. This can be done, for example, by microprocessor **36**. In the embodiment illustrated in **FIG. 12**, the pulse oximeter includes a pulse oximeter sensor **39** in contact with the patient to measure the oxygen saturation SpO₂ of patient **37**.

[0098] The present invention contemplates that cardiac output measurement device **30** includes an input/output interface **40** for communicating with the user. For example, a display or other indicator may be provided that notifies the user when to induce that change in arterial oxygen concentration, as well as outputs the cardiac measurement result. A communication link **42** can also be provided for downloading or receiving information and commands to or from a remote location.

[0099] One embodiment of the present invention contemplates that one or more of the patient flow measurement system, the oxygen analyzing system, and the fractional arterial oxygen concentration measuring system can be implemented in a separate, stand-alone, module with the output of each being provided to processor **36**. This enables different types of patient flow, oxygen analyzing, and arterial oxygen concentration measuring systems to be used with a common cardiac output determination module. One benefit being that existing patient flow sensors, oxygen analyzers, and arterial oxygen concentration measuring systems, such as a conventional pulse oximeter, can be used to provide the required inputs to the cardiac output module.

[0100] However, the present invention also contemplates that patient flow measuring system, the oxygen analyzing system, and arterial oxygen concentration measuring system, or any combination thereof, can be integrated into a single housing **43**, as shown, for example, in **FIG. 12**. In this embodiment, the measuring elements of each system, such as the flow element **33**, the airway adapter and O₂ transducer **35**, and the pulse oximeter sensor **39**, provide inputs, e.g., electronic, optical, pneumatic, or otherwise, to one or more processing systems in housing **43**.

[0101] Also necessary for purposes of the present invention, as shown in **FIG. 12**, is a device or technique, generally indicated at **50**, for inducing a change in the patient's arterial oxygen concentration. In the illustrated exemplary embodiment, device **50** is a rebreathing system that captures the patient's expired gas in a collection reservoir **52**. A valve **54**

controls the flow of gas, so that when the cardiac output system is not actuated, the patient's airway communicates with ambient atmosphere or a conventional ventilator or pressure support system (not shown). In this embodiment, when the cardiac output is to be measured, valve **54** is controlled manually or via processor **36**, to cause the patient's exhaled gas passed to reservoir **52** where it is collected. Because the gas collected in reservoir **52** has been exhaled by the patient, its oxygen concentration is significantly reduced.

[0102] In a further embodiment of the present invention, a device **56** for removing CO₂ is included in rebreathing system **50**, so that the spontaneously breathing patient does not rebreathe significant amounts of CO₂. In a preferred embodiment of the present invention, device **56** is a CO₂ scrubber that removes CO₂ from the gas passing there-through. As noted above, for a non-spontaneously breathing patient, CO₂ removal device **56** is optional, because their breathing pattern is controlled by the ventilator regardless of the CO₂ levels inhaled by the patient.

[0103] Although the invention has been described in detail for the purpose of illustration based on what is currently considered to be the most practical and preferred embodiments, it is to be understood that such detail is solely for that purpose and that the invention is not limited to the disclosed embodiments, but, on the contrary, is intended to cover modifications and equivalent arrangements that are within the spirit and scope of the appended claims.

What is claimed is:

1. A method for measuring cardiac output comprising:
 - (1) quantitatively measuring a patient's airflow, a first parameter indicative of a percent oxygen inhaled and exhaled by such a patient, and a second parameter indicative of such a patient's fractional arterial oxygen concentration;
 - (2) inducing a change in such a patient's arterial oxygen concentration;
 - (3) repeating the airflow, the first parameter and the second parameter measurements set forth in step (1); and
 - (4) determining the patient's cardiac output based on the airflow, the first parameter, and the second parameter information collected in steps (1) and (3).
2. The method according to claim 1, wherein the second parameter indicative of fractional arterial oxygen concentration is one of SaO₂, PaO₂, CaO₂ or SpO₂.
3. The method according to claim 1, wherein measuring the airflow includes providing a flow sensor proximate to such a patient's airway, wherein the flow sensor outputs a flow signal indicative of a flow of breathing to or from such a patient.
4. The method according to claim 1, wherein measuring the first parameter includes providing an oxygen analyzing element proximate to such a patient's airway, wherein the oxygen analyzing element outputs an oxygen concentration signal indicative of an amount of oxygen in gas passing through the oxygen sensor.
5. The method according to claim 1, wherein measuring the second parameter includes providing a pulse oximeter sensor in contact with such a patient, wherein the pulse

oximeter sensor output a signal indicative of an oxygen saturation SaO_2 of such a patient.

6. The method according to claim 1, wherein inducing a change in such a patient's arterial oxygen concentration includes introducing a non-oxygen breathing gas into a stream of gas to be inhaled by such a patient.

7. The method according to claim 1, wherein inducing a change in such a patient's arterial oxygen concentration includes rebreathing gas exhaled by such a patient.

8. The method according to claim 7, wherein rebreathing includes removing carbon dioxide CO_2 from the exhaled gas before the exhaled gas is rebreathed.

9. The method according to claim 1, wherein determining the patient's cardiac output includes:

determining a deviation of such a patient's oxygen uptake from a baseline oxygen uptake level occurring responsive to the induced change in such a patient's arterial oxygen concentration in step (2);

determining a deviation of such a patient's arterial oxygen concentration from a baseline arterial oxygen concentration level occurring responsive to the induced change in such a patient's arterial oxygen concentration in step (2); and

comparing the deviation in oxygen uptake to the deviation in arterial oxygen concentration.

10. The method according to claim 9, wherein determining the deviation of such a patient's oxygen uptake includes determining an effective area between the baseline oxygen uptake level and an oxygen uptake curve occurring responsive to the execution of step (2), and wherein determining the deviation of such a patient's arterial oxygen concentration includes determining an effective area between the baseline arterial oxygen concentration level and an arterial oxygen concentration curve occurring responsive to the execution of step (2).

11. The method according to claim 9, wherein determining the deviation of such a patient's oxygen uptake includes determining a slope of a line extending between the baseline oxygen uptake level and a point on an oxygen uptake curve occurring responsive to the execution of step (2), and wherein determining the deviation of such a patient's arterial oxygen concentration includes determining a slope of a line extending between the baseline arterial oxygen concentration level and a point on an arterial oxygen concentration curve occurring responsive to the execution of step (2).

12. The method according to claim 9, wherein determining the deviation of such a patient's oxygen uptake includes determining a magnitude between the baseline oxygen uptake level and a point on an oxygen uptake curve occurring responsive to the execution of step (2), and wherein determining the deviation of such a patient's arterial oxygen concentration includes determining a magnitude between the baseline arterial oxygen concentration level and a point on an arterial oxygen concentration curve occurring responsive to the execution of step (2).

13. The method according to claim 1, further comprising outputting, in human perceivable form, an indication of the cardiac output determined in step (4).

14. An apparatus for measuring cardiac output comprising:

a patient flow measuring system adapted to quantitatively measuring a patient's airflow;

an oxygen analyzing system adapted to measure a first parameter indicative of a percent oxygen inhaled and exhaled by such a patient;

means for measuring a second parameter indicative of such a patient's fractional arterial oxygen concentration;

means for inducing a change in such a patient's arterial oxygen concentration;

a processor adapted to determine such a patient's cardiac output based on the output of the measured airflow, the first parameter, and the second parameter; and

outputting means for outputting a result indicative of such a patient's cardiac output in human perceivable form.

15. The apparatus according to claim 14, wherein the means for measuring the second parameter is a pulse oximetry system including a pulse oximeter sensor in contact with such a patient.

16. The apparatus according to claim 14, wherein the second parameter indicative of fractional arterial oxygen concentration is one of SaO_2 , PaO_2 , CaO_2 or SpO_2 .

17. The apparatus according to claim 14, wherein the patient flow measuring system includes a flow sensor disposed proximate to such a patient's airway such that gas inhaled and exhaled by the patient passes through the flow sensor.

18. The apparatus according to claim 14, wherein the oxygen analyzing system includes an oxygen analyzing element comprising (a) an airway adapter having an optical window and (b) an oxygen transducer having a photoemitter and a photodetector, and wherein the oxygen analyzing element is disposed proximate to such a patient's airway such that gas inhaled and exhaled by such a patient passes in front of the optical window.

19. The apparatus according to claim 14, wherein the means for inducing a change in such a patient's arterial oxygen concentration comprises a system for introducing a non-oxygen breathing gas into a stream of gas to be inhaled by such a patient.

20. The apparatus according to claim 14, wherein the means for inducing a change in such a patient's arterial oxygen concentration comprises a rebreathing system for causing such a patient to rebreathe gas exhaled by such a patient.

21. The apparatus according to claim 20, wherein the rebreathing system further comprises means for removing carbon dioxide CO_2 from the exhaled gas before the exhaled gas is rebreathed.

22. The apparatus according to claim 14, wherein the processor determines:

(a) a deviation of such a patient's oxygen uptake from a baseline oxygen uptake level occurring responsive to an induced a change in such a patient's arterial oxygen concentration;

(b) a deviation of such a patient's arterial oxygen concentration from a baseline arterial oxygen concentration level occurring responsive to an induced a change in such a patient's arterial oxygen concentration; and

(c) compares the deviation in oxygen uptake to the deviation in arterial oxygen concentration.

23. The apparatus according to claim 22, wherein the processor determines the deviation of such a patient's oxy-

gen uptake by determining an effective area between the baseline oxygen uptake level and an oxygen uptake curve occurring responsive to the induced change in such a patient's arterial oxygen concentration, and determines a deviation of such a patient's arterial oxygen concentration by determining an effective area between the baseline arterial oxygen concentration level and an arterial oxygen concentration curve occurring responsive to the induced change in such a patient's arterial oxygen concentration.

24. The apparatus according to claim 22, wherein the processor determines the deviation of such a patient's oxygen uptake by determining a slope of a line extending between the baseline oxygen uptake level and a point on an oxygen uptake curve occurring responsive to the induced change in such a patient's arterial oxygen concentration, and determines the deviation of such a patient's arterial oxygen concentration by determining a slope of a line extending

between the baseline arterial oxygen concentration level and a point on an arterial oxygen concentration curve occurring responsive to the induced change in such a patient's arterial oxygen concentration.

25. The apparatus according to claim 22, wherein the processor determines the deviation of such a patient's oxygen uptake by determining a magnitude between the baseline oxygen uptake level and a point on an oxygen uptake curve occurring responsive to the induced change in such a patient's arterial oxygen concentration, and determines the deviation of such a patient's arterial oxygen concentration by determining a magnitude between the baseline arterial oxygen concentration level and a point on an arterial oxygen concentration curve occurring responsive to the induced change in such a patient's arterial oxygen concentration.

* * * * *

专利名称(译)	用于确定心输出量的方法和装置		
公开(公告)号	US20040171950A1	公开(公告)日	2004-09-02
申请号	US10/763971	申请日	2004-01-23
申请(专利权)人(译)	RESPIRONICS , INC.		
当前申请(专利权)人(译)	RIC投资有限责任公司.		
[标]发明人	STARR ERIC W PENNOCK BERNARD KANDIS MOUHYIELDIN		
发明人	STARR, ERIC W. PENNOCK, BERNARD KANDIS, MOUHYIELDIN		
IPC分类号	A61B5/00 A61B5/026 A61B5/029 A61B5/08 A61B5/083 A61B5/087 A61B5/145 A61B5/1455 A61B5/02		
CPC分类号	A61B5/0833 A61B5/029		
优先权	60/161120 1999-10-22 US		
其他公开文献	US7367954		
外部链接	Espacenet USPTO		

摘要(译)

一种用于确定心输出量的方法和装置。该方法包括定量测量患者的气流，第一参数指示患者吸入和呼出的氧气百分比，以及第二参数指示患者的分数动脉血氧浓度。该方法还包括诱导患者动脉氧浓度的变化，同时进行这些测量以监测患者动脉氧浓度变化的影响。心输出量是根据收集的关于患者动脉血氧浓度变化影响的数据确定的。

