



US 20020082486A1

(19) **United States**

(12) **Patent Application Publication**

Lavery et al.

(10) **Pub. No.: US 2002/0082486 A1**

(43) **Pub. Date: Jun. 27, 2002**

(54) **FOOT TEMPERATURE AND HEALTH MONITORING SYSTEM**

Publication Classification

(51) **Int. Cl.⁷ A61B 5/00**

(52) **U.S. Cl. 600/300**

(76) **Inventors: Lawrence A. Lavery**, Naperville, IL (US); **C. Mauli Agrawal**, San Antonio, TX (US); **Kyriacos A. Athanasiou**, Houston, TX (US); **George P. Constantinides**, San Antonio, TX (US); **Dan R. Lanctot**, San Antonio, TX (US); **Ruben G. Zamorano**, San Antonio, TX (US)

(57) **ABSTRACT**

The present invention provides an apparatus and method for monitoring skin temperatures at predetermined locations on the body of a human or an animal. One embodiment includes a platform with a grid including holes on which the user stands. Under the grid is a movable array of light sensors and temperature sensors. The foot position is determined from the output of the light sensors. The temperatures at predetermined locations on the skin surface are determined by the signals obtained from the temperature sensors. Additional vital health information may be obtained by other sensors on the apparatus. The data may be stored for future retrieval, or transmitted to a remote location for off-site monitoring. Alternative embodiments include sensor blankets or wraps whereby temperature sensors monitor skin temperature for areas of pressure on the blanket or areas covered by the wrap.

Correspondence Address:

Alan R. Thiele
Jenkins & Gilchrist, P.C.
Suite 3200
1445 Ross Avenue
Dallas, TX 75202 (US)

(21) **Appl. No.: 10/029,043**

(22) **Filed: Dec. 20, 2001**

Related U.S. Application Data

(63) **Continuation-in-part of application No. 09/578,948, filed on May 25, 2000.**

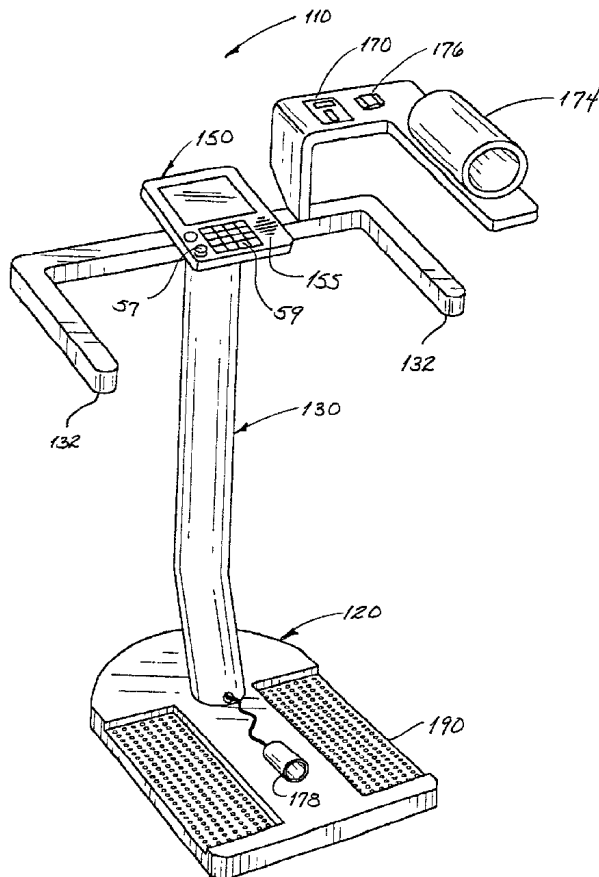

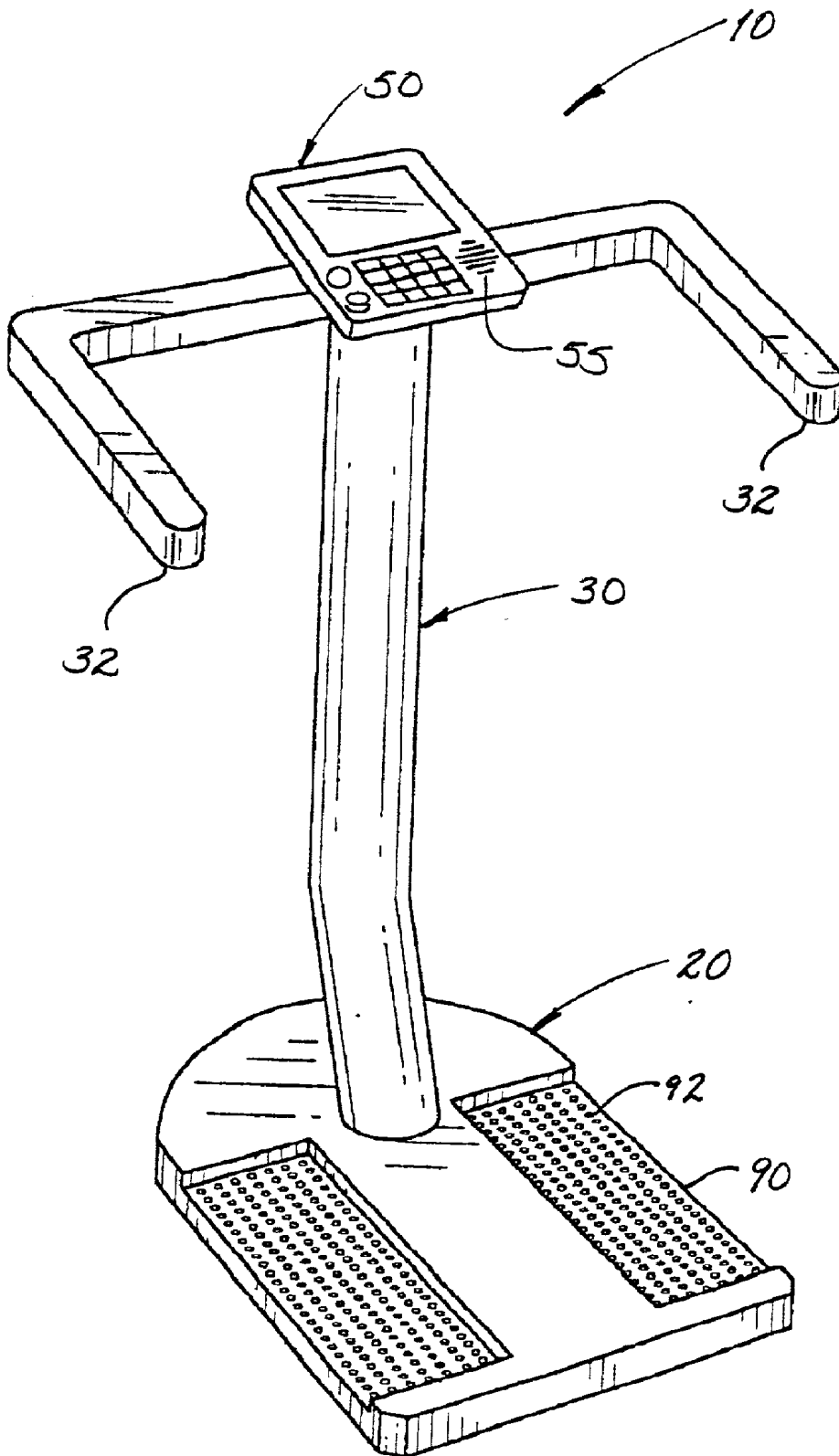

Fig. 1

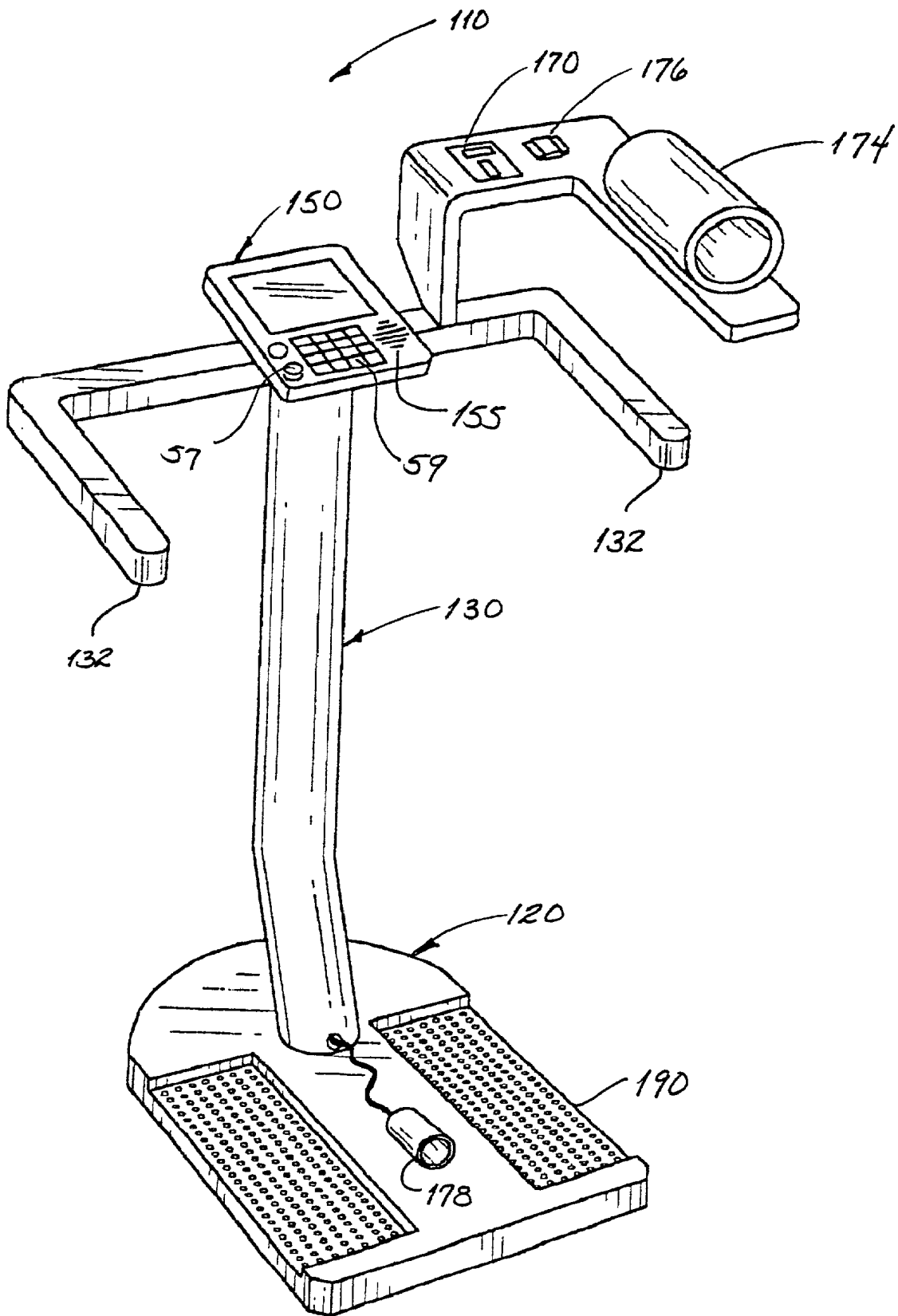
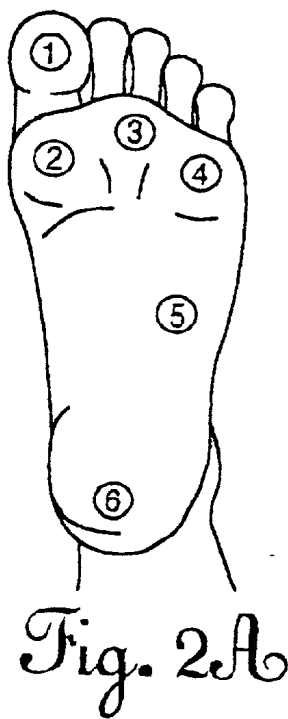
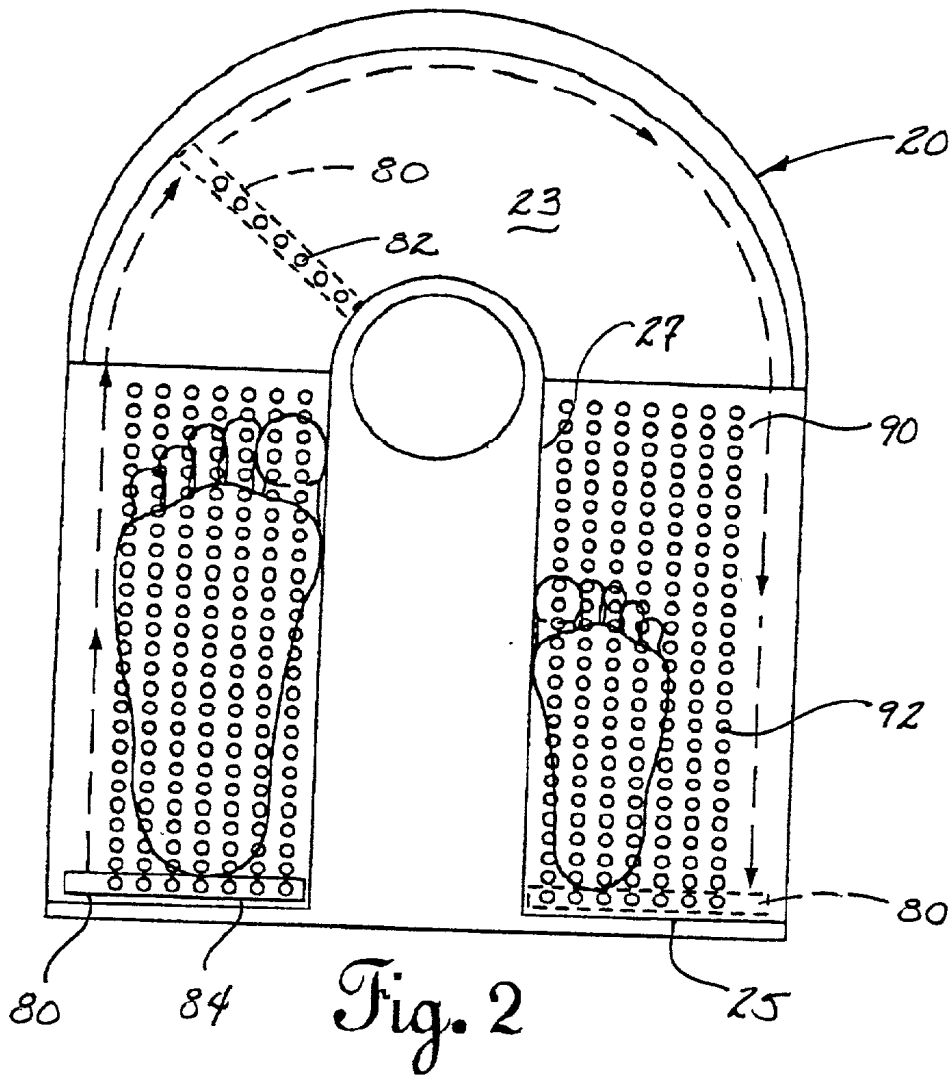

Fig. 1A



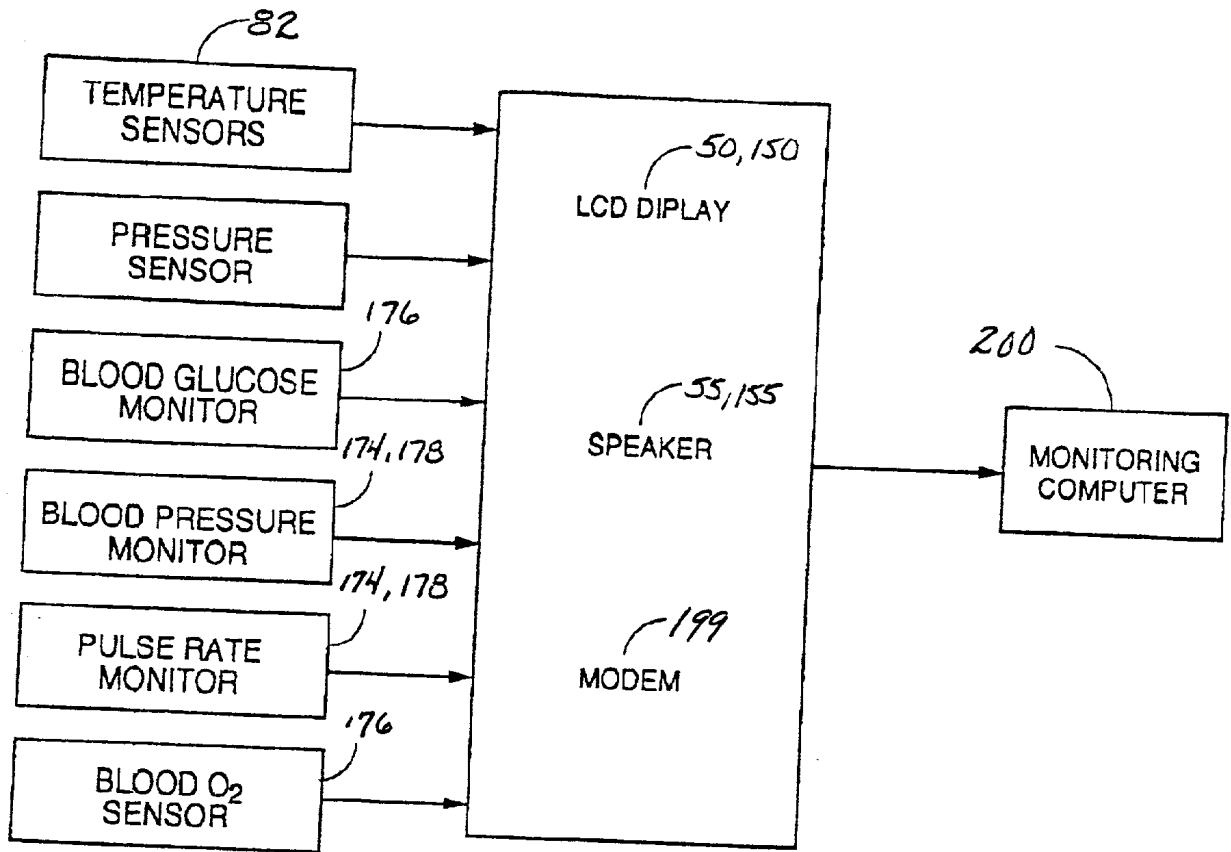

Fig. 3

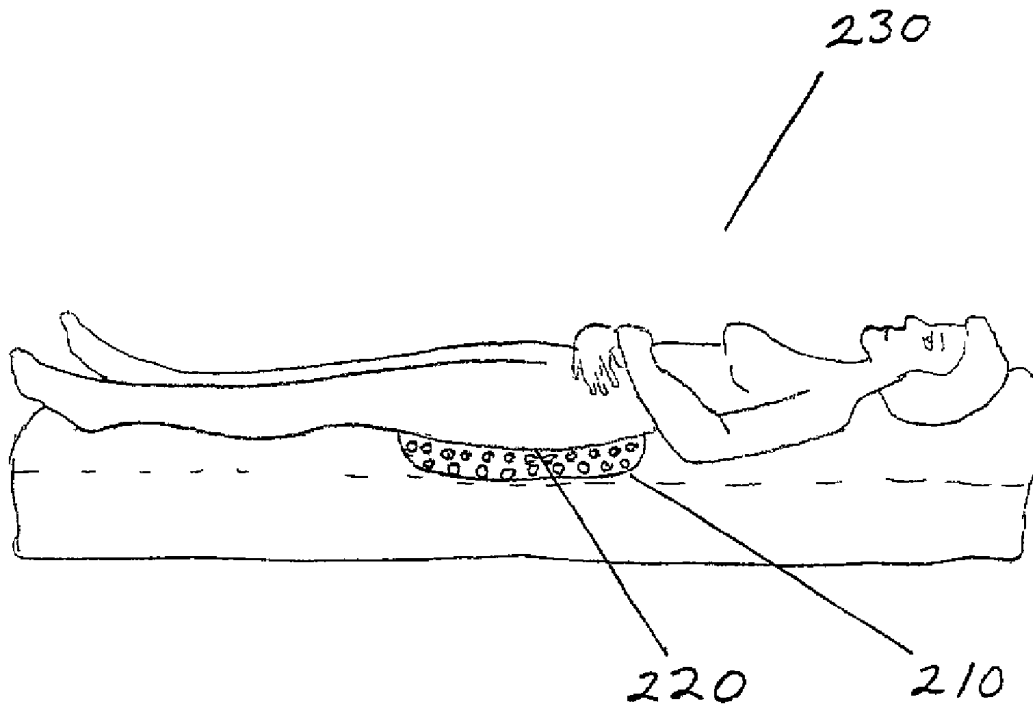

Fig. 4

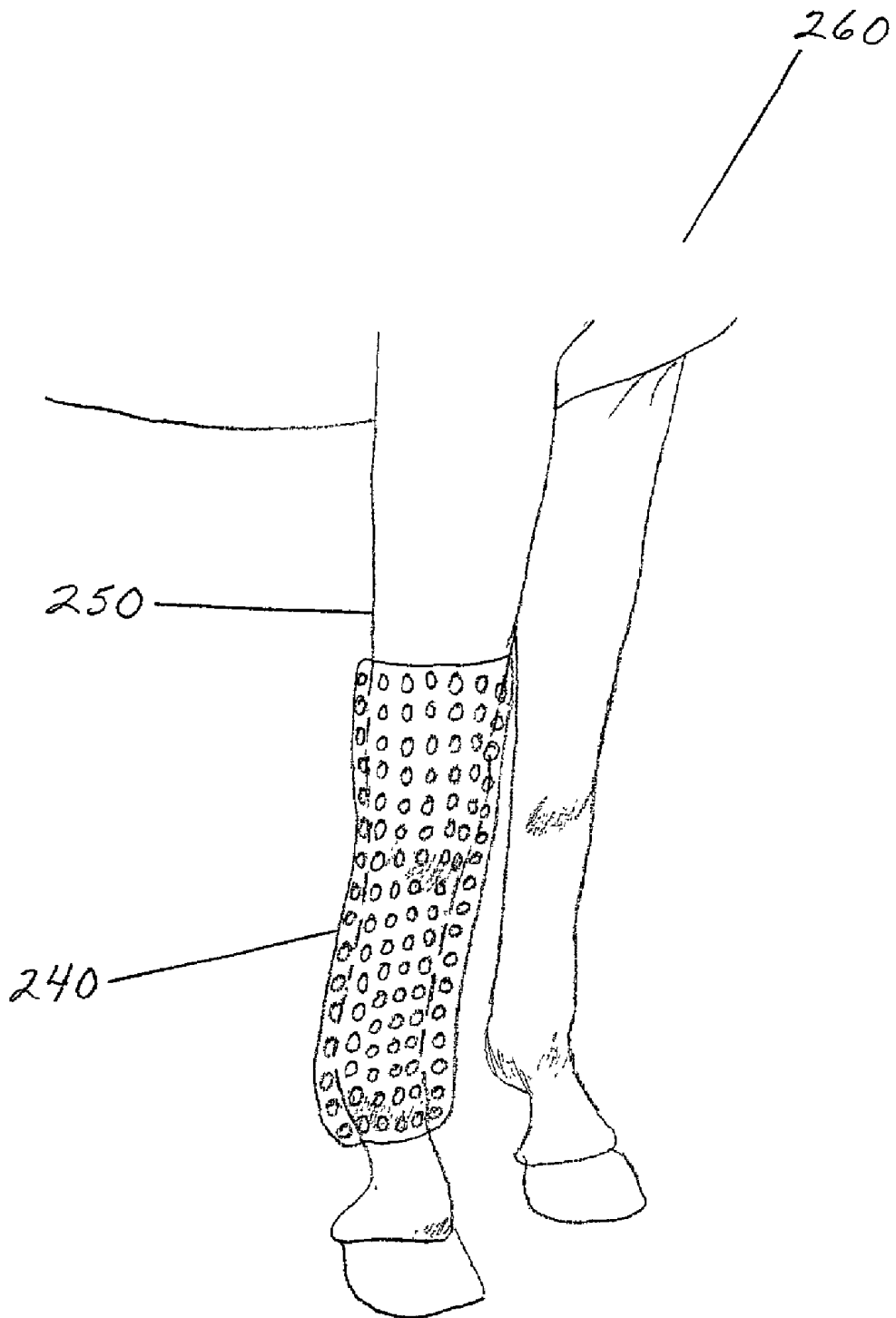

Fig. 5

FOOT TEMPERATURE AND HEALTH MONITORING SYSTEM

[0001] This is a continuation-in-part of U.S. patent application Ser. No. 09/578948, filed on May 25, 2000.

FIELD

[0002] The present invention pertains to a monitoring apparatus; more particularly, the present invention pertains to an apparatus and method for monitoring the skin temperatures of animals at different predetermined locations together with other vital information indicative of the health of a human being.

BACKGROUND

[0003] Many conditions which have a negative impact on the health of animals, to include human beings, are preceded by small changes in skin temperature, together with slight changes in weight or blood pressure. For example, a significant weight gain may be indicative of fluid retention. And fluid retention, when accompanied by an increase in blood pressure, may be predictive of the onset of congestive heart failure.

[0004] Afflictions, particularly ulcerations, can be predicted by a change in skin temperatures. Specifically, the skin temperature on the bottom of the feet can be predictive of foot problems such as ulcerations. In the United States alone, it is estimated that up to 16,000,000 people suffer from diabetes; and approximately 60-70% of these diabetics will eventually develop foot-related medical problems sometime during their lifetime. Of all diabetes-related hospitalizations, 20% of these hospitalizations are for foot-related medical problems. The number of hospitalizations for foot-related medical problems, such as sores that will not heal, can be reduced if medical personnel are forewarned of significant changes in the skin temperatures on the bottom of the feet. For example, it is well known that skin temperatures on the bottom of a person's feet will increase before a visible ulceration appears.

[0005] Afflictions that cause tissue inflammation and injury, such as tendon injuries and fractures, ulcers in persons with neuropathy or who are bedridden, can be predicted or identified by subtle changes in skin temperatures. For instance, in diabetics with neuropathy elevated skin temperatures on the sole of the foot can help medical personnel identify areas prone to ulceration or fracture. For patients who are bedridden, elevated skin temperatures can help identify specific areas on the heels, buttocks or sacrum that are injured, inflamed and are at the early stages of developing a decubitus ulceration or pressure sore. The capability of identifying locations prone to ulcerations is particularly helpful for persons with diminished cognitive function or who are so debilitated that they do not have verbal skills to provide information to their care-givers. Such patients may include those with spinal cord injury or stroke victims.

[0006] Foot problems are particularly problematic for diabetics because diabetics often lose sensation in their feet. This loss of sensation often leads to a foot fracture (Charcot) or a skin ulceration caused by friction and pressure. In extreme cases the ulceration, if not caused to heal properly, may eventually lead to an amputation of a diabetic's foot.

The foot problems typically associated with diabetic peripheral neuropathy include numbness or insensitivity to pain or temperature, tingling, burning, or prickling, sharp pains or cramps, extreme sensitivity to touch, and loss of balance and coordination. Such pain and suffering significantly diminishes the quality of life of a diabetic. In addition, foot-related medical problems substantially increase the diabetic's health care cost.

[0007] There is therefore a need in the art for a device and system which facilitates the monitoring of skin temperatures. For diabetics particularly, there is a need in the art for a device and system which will monitor skin temperatures on the bottom of a patient's feet and provides an early warning of any significant temperature differences in skin temperatures between common areas of the two feet or between neighboring sites. Such foot skin temperature monitoring may provide an early indication of conditions which can lead to ulceration, infection, wound healing problems, fracture, and even amputation.

[0008] In yet another important area for diabetics, changes in blood pressure at various locations on the human body may be indicative of reduced blood flow. Such reduced blood flow may lead to significant reduction in the health of the affected body part. Another important area of observation for diabetics would be changes in blood chemistry which may be indicative of nascent problems which are not yet symptomatic. Coupling this information together with foot skin temperatures would create an extremely powerful tool for diagnosticians.

[0009] The ability to monitor skin temperatures at predetermined areas can also be expanded to use in animals such as race horses. By serial temperature monitoring, areas prone to injury can be identified and treated before a career-ending or catastrophic injury. This methodology can also be used to evaluate and monitor the effectiveness of treatment in those animals since they are obviously unable to communicate to their veterinarian about the severity or location of the pain.

[0010] Thus, there is a significant need to develop a device to facilitate the monitoring of skin temperature at predetermined areas together with other vital health information such as weight, blood pressure, and blood glucose levels. Such monitoring of other vital information, when coupled with skin temperature readings, may provide an early indication of pending serious health problems which, if treated early, can be substantially diminished or even avoided.

SUMMARY

[0011] The present invention facilitates the monitoring of skin temperatures at predetermined locations on a human's or animal's body to include the skin temperature on the bottom, side, or top of a person's foot. In an alternate embodiment, the disclosed invention couples skin temperature readings together with other important health indicators such as body weight and blood pressure. This monitoring of vital health information is accomplished by an apparatus which is built around a system for monitoring the skin temperature at different predetermined locations. For diabetics, these predetermined locations may be on the plantar, dorsal, medial, or lateral aspects of the contra-lateral feet.

[0012] In the disclosed preferred embodiment of the invention, a platform includes a moving array of light

sensors and infrared temperature sensors positioned under a grid on which the patient stands. The light sensor portion of the moving array determines the position of the patient's feet on the grid. The infrared temperature sensors of the moving array determines foot skin temperatures as it travels under the grid. Holes in the grid allow each infrared temperature sensor to make numerous temperature measurements of the skin on the bottom of each foot. Once the foot skin temperatures have been taken through each hole in the grid covered by the patient's foot, the temperature measurements at each location can be transmitted to and stored in a computer memory. The computer memory may be located at the device itself, or the foot skin temperature data may be transmitted to a computer memory at a remote location using a built-in modem and a telephone connection or via wireless means.

[0013] If there is a significant difference between the skin temperatures on the bottom of the left foot and the bottom of the right foot, or a difference between adjacent points, an alarm signal can be provided to the user. The sensed skin temperatures can also be displayed to the user as a temperature reading, stored for future use, or sent to a central monitoring facility.

[0014] In another embodiment, force or pressure sensors co-located with the grid on which the patient stands may also be used to locate positions on the foot that will be measured with the temperature sensors. The patient's weight is measured by means of traditional force sensors located at each leg of the device. In still other embodiments, a blood pressure cuff and pulse monitor may be used. The blood pressure cuff may be placed at heart level on the user's arm or an additional pulse monitor cuff may be placed around the user's ankle or the user's toe. A further embodiment could monitor and transmit blood glucose levels.

[0015] Once vital health information has been sensed, that information may be compared to previously sensed vital health information. For example, a comparison of a patient's weight and blood pressure to prior readings may reveal a condition predictive of congestive heart failure.

[0016] All of the sensed vital health information may be displayed to the user and/or transmitted by telephone or other commonly used wireless communication systems to a central facility where medical professionals can determine if the sensed conditions are predictive of imminent medical problems. If desired, the apparatus itself may produce alarms of particularly dangerous conditions. For example, if the difference in the skin temperatures sensed on the bottom of the left foot and the bottom of the right foot or if the patient's blood pressure is above a certain level, an audible signal or a visual message can be generated, indicating an urgent need to consult with a medical professional.

[0017] In another embodiment, a blanket containing temperature sensors may be placed under a body part, particularly a body part which is most likely to develop a decubitus ulcer due to immobility. The apparatus may also be designed in the form of a wrap containing temperature sensors, which can be positioned around an extremity of a human being or animal in order to monitor the skin surface temperature of the body part contained therein.

BRIEF DESCRIPTION OF THE FIGURES

[0018] A better understanding of the apparatus and method for monitoring the temperature on the planar aspects of a

human foot and other vital health information may be had by reference to the drawings, wherein:

[0019] FIG. 1 is a perspective view of the preferred embodiment of the present invention;

[0020] FIG. 1A is a perspective view similar to FIG. 1 illustrating the inclusion of additional features;

[0021] FIG. 2 is a top plan view of the platform which is used to measure the temperatures on the plantar aspects of the user's feet;

[0022] FIG. 2A is a bottom view of a patient's foot indicating typical locations used for sensing skin temperature;

[0023] FIG. 3 is a schematic diagram of the interrelationship of the main components of the present invention;

[0024] FIG. 4 is an illustration of the skin temperature monitoring apparatus in the form of a sensor blanket placed under the buttocks of a patient; and

[0025] FIG. 5 is an illustration of the skin temperature monitoring apparatus in the form of an extremity wrap placed around the leg of a horse.

DESCRIPTION OF THE EMBODIMENTS

[0026] As may be seen in FIG. 1, the preferred embodiment of the invention 10 includes a platform assembly 20 on which the patient stands, a pedestal assembly 30, and a readout panel assembly 50. The pedestal assembly includes a pair of arms 32 which a patient may use for support when stepping on the platform assembly 20 and for mounting additional equipment as shown in FIG. 1A.

[0027] As may be seen in FIG. 2, the platform assembly 20 includes a movable substantially linear array 80 of infrared sensors 82 on a moving frame 84. In the embodiment shown in FIG. 2, the movable linear array 80 of infrared sensors includes seven sensors 82. Those of ordinary skill in the art will understand that the number of sensors 82 used in the linear array 80 is dependent on the number of locations on the bottom of the patient's foot at which a physician may request skin temperatures and the typical size of the patient's foot. The linear array 80 of infrared sensors 82 moves first under one foot and then under the other foot. Skin temperatures are taken through the holes 92 in a grid plate 90 on which the patient actually stands.

[0028] While a linear array 80 of infrared temperature sensitive sensors 82 is shown in the preferred embodiment, those of ordinary skill in the art will understand that other non-contact temperature sensing systems suitable for rapid sensing of temperatures at point locations may also be used.

[0029] As shown in FIG. 2, the linear array 80 of infrared sensors 82 begins its travel path on the left side of the platform assembly 20. To illustrate that the platform assembly is sized to accommodate a wide range of foot sizes, the linear array 80 of infrared sensors 82 is shown passing under a man's foot size 16E from heel to toe. Once the traverse of the foot on the left side of the platform assembly 20 is complete, the linear array 80 of infrared sensors 82 is guided on an arcuate path 23 to the patient's other foot on the right side. In FIG. 2, the other foot is shown as a woman's size 5A to indicate that a small foot size does not present any

difficulties for the person using the device **10**. Once the arcuate path **23** has been traversed, the linear array **80** of infrared temperature sensors **82** passes under the foot on the right side of the device **10** from toe to heel, taking skin temperature measurements along the bottom of the user's foot as it goes along.

[0030] Skin temperature measurements are available at all points at which there is an opening **92** in the grid **90** on the platform assembly **20**. A complete array of such skin temperature readings may be used to produce complex diagrams of foot skin temperatures where colors are used to represent varying ranges of foot skin temperature. Alternatively, a physician may be interested in skin temperatures at specific predetermined locations on a patient's foot such as the ones shown in **FIG. 2A**. Where skin temperature readings at only predetermined locations are required, the computer receiving the skin temperature only selects those temperature readings at the predetermined locations such as shown in **FIG. 2A** for reporting purposes and disregards the remainder. For smaller feet, at least 50 discrete skin temperature measurements can be taken. For larger feet, up to 150 discrete skin temperature measurements can be taken. For those skilled in the art, an even higher number of discrete points may be assessed.

[0031] The movement of the linear array **80** of infrared sensors **82** is facilitated by a small motor located within the platform assembly **20** (not shown). Because of the arcuate movement or U-Turn taken by the linear array **80** of infrared sensors **82** at the top of the platform assembly **20**, the same infrared sensor **82** measures the skin temperature at a predetermined location on each foot, thus minimizing any sensing error. For example, if the first infrared temperature sensor **82** in the linear array **80** measured the skin temperature on the bottom of the big toe in the left foot (location **1** in **FIG. 2A**), the same infrared temperature sensor would measure the skin temperature on the bottom of the big toe on the patient's right foot.

[0032] It is expected that the patients who would receive the greatest benefit from the disclosed apparatus are diabetics who are typically at high risk for developing medical complications on their lower extremities, particularly their feet.

[0033] In an alternate embodiment of the present invention **10** as shown in **FIG. 1A**, the patient may obtain a quick scan of the temperatures on the plantar aspects of both feet, body weight, and blood pressure. Items similar to those shown in **FIG. 1** are designated by reference numbers including a 1 in the hundreds place.

[0034] The quick scan of foot temperatures allows the detection and monitoring of differences in skin temperatures between the bottom of the left foot and the bottom of the right foot or the monitoring of foot temperatures at different locations on the bottom of the patient's foot over time. Variations in foot skin temperatures often signal conditions which are predictive of inflammation or ulceration and which conditions, if left untreated, may lead to eventual amputation of an entire lower extremity.

[0035] As shown in **FIG. 1** and **FIG. 1A**, the apparatus of the present invention **10, 110** is not unlike a commonly used bathroom scale for determining body weight. Specifically, the user is instructed to first step on the platform **20, 120**.

The location of the patient's foot is initially located by causing the heel to be placed against a first rear surface **25** and the medial aspect of the foot to be placed against a second surface **27** substantially perpendicular to the first rear surface **25**. Further information concerning the location of the patient's foot may be determined by an array of pressure sensors (not shown) located in the platform assembly **120** or an array of optical light sensors (not shown) located in the platform assembly **20**. Additional background light can be projected downward from the handles **32** of the apparatus **10** in order to clearly distinguish the outline of the patient's feet. In the disclosed embodiment, the position of each foot is determined from the information received from the light sensors included with the linear array **80** of infrared temperature sensors **92** which traverses the bottom of each foot several times. Because the pressure of a patient's foot blocks ambient light from passing through the holes in the grid, light to the light sensors will be blocked while light will pass through the uncovered holes in the grid. This provides a light picture of the position and size of a patient's foot on the grid. Once the computer receiving the information on foot size and position from the light sensors in the linear array **80** determines the position of the foot on the grid **90**, the temperature sensors measure the temperature at preselected sites on the bottom or plantar aspects of both feet. Alternatively, the position and size of a patient's foot on the grid may be located by creating a temperature picture of the patient's foot using techniques well known to those of ordinary skill in the art.

[0036] The device **10, 110** will alert the user if there is an abnormally high skin temperature gradient between the plantar, dorsal, lateral, or medial aspects of the contralateral feet. The presence of such a significant skin temperature gradient may be indicative of a pathologic inflammation or possible tissue damage at that location on the user's foot. Such inflammation or tissue damage might be an indicator of a predisposition to further tissue breakdown in the foot and/or significant morbidity which, if left untreated, may lead to an amputation or, in extreme cases, death.

[0037] As shown in **FIG. 1** and **FIG. 1A**, the apparatus of the present invention **10, 110** is built around a platform assembly **20, 120** that is placed on a hard surface (not shown). The first **25** and second surfaces **27** are used to guide the initial placement of the patient's feet on the platform assembly **20**. These surfaces assist the patient in placing his/her feet reproducibly and accurately on the platform assembly **20**. For patients with unusually shaped or deformed feet, custom fabricated foot placement surfaces or replaceable inserts may be used with the grid plate **90**.

[0038] In the preferred embodiment shown in **FIG. 1**, light sensors are used to determine the location of the user's feet on the platform **20**. This location information is then used to select the particular holes **92** in the grid **90** through which the infrared temperature sensors **82** can measure the foot sole skin temperature.

[0039] The infrared temperature sensors **82**, provide an electrical signal representative of a skin temperature level at the predetermined location of a hole **92** in the grid **90**. These electrical signals may then be displayed as either Fahrenheit or Celsius temperature readings to the patient or a medical professional.

[0040] If desired a liquid crystal display **50, 150** can either show the actual temperature values measured by one or

more infrared temperature sensors **82** and/or alert the user that a difference in temperature may exist between two sensor sites. Alternatively, the temperature readings or warnings about possibly dangerous temperature differences may be conveyed audibly to the user through one or more speakers **55**, **155**.

[0041] As shown in **FIG. 1A**, it has also been found that the utility of the apparatus **110** for monitoring the temperature of the plantar aspects of the human foot can be expanded to measure other vital health information through the use of a variety of different enhancements. Specifically, the apparatus of the present invention can easily be modified to also measure the weight of the patient by placing pressure sensitive transducers (not shown) in the platform assembly **20**. The measurement of weight is important because fluctuations in weight may be significant to patients in the different stages of congestive heart failure. Such sudden weight change usually signifies a dangerous buildup of water or liquid retention. The need to monitor fluctuations in weight is particularly important for diabetics who are prone to suffer from congestive heart failure. Thus, it is desirable for diabetics that the foot temperature variations and body weight changes be quantified and displayed on a daily basis. Selection of the health information displayed is facilitated by the use of easily accessible buttons **57** or a keypad **59** as shown in **FIG. 1A**.

[0042] If desired, body weight may be measured with the apparatus using a force or pressure transducer in the same way that force or pressure transducers are used in standard bathroom scales. The liquid crystal display **150** may be used for the display of body weight.

[0043] It has also been found that the preferred embodiment of the apparatus **110** of the present invention may be further enhanced by the addition of still other medical condition monitoring systems well known to those of ordinary skill in the art. Such other medical condition monitoring systems may measure blood glucose levels with a finger pin stick system **170**, an arm blood pressure cuff and pulse counter **174**, or a red light and light sensor **176** for transcutaneous monitoring, clipped on the end of a finger to measure blood oxygen levels. Present technology enables the measurement of blood glucose levels and blood oxygen levels using a variety of techniques including lasers, infrared percutaneous readings or assessment of blood glucose levels using the patient's saliva. Blood pressure and pulse may even be sensed on the foot or lower leg with an ankle cuff or toe cuff **178**.

[0044] As shown in **FIG. 3**, once the vital health information has been obtained by the apparatus **10**, **110** of the present invention, it may be stored internally where it can be compared with prior data to inform the user of noticeable trends in changes of weight or temperature and, if necessary, provide an alarm signal. Alternatively, the information may be sent to a central computer **200** using a modem **199** connected to a standard telephone system, the internet, cell phone, or other wireless communication means. The central computer **200** monitors the measurements of vital health information taken by the device **10**, **110** and thereby allows such measurements to be taken by patients in the comfort of their own home.

[0045] As shown in **FIG. 4**, the apparatus may be designed in the form of a sensor blanket **210**. The sensor

blanket **210** may be positioned under any of the body parts most likely to develop decubitus and other pressure sores and ulcers when a person is primarily bedridden. These areas may include the iliac crest, trochanter, ischium, sacrum, and coccyx. For the monitoring of these hip and spinal bones, the sensor blanket **210** would be positioned under the buttocks **220** when the person **230** is in a supine position as illustrated in **FIG. 4**.

[0046] As shown in **FIG. 5**, the apparatus may be designed in the form of a wrap **240**. The wrap **240** may be positioned around an extremity of a human being or animal. **FIG. 5** illustrates the wrap **240** positioned around the leg **250** of a horse **260**.

[0047] Operation

[0048] The embodiment of the present invention illustrated in **FIGS. 1, 1A, and 2** is designed to be utilized if the patient is standing. A key aspect of the present invention is to assure that the location of the patient's feet are properly located with respect to the array of infrared temperature sensors **82** located in the platform assembly **20**. Specifically, the computer receiving the sensed skin temperature information must be able to tie a location on the bottom of the patient's foot to the sensed temperature.

[0049] In a preferred embodiment the data collected by the apparatus **10**, **110** will be marked with an indication of the date and time the skin temperature readings were taken. All sensed information to include the date and time that readings were taken may be stored at the device **10**, **110** itself or transmitted to a remote location by standard telephone wires or wireless means where it may be stored and later analyzed.

[0050] If the data is transmitted to a database at a remote location, it would then be possible for a health care professional to monitor the data and determine if a significant change has occurred in the contralateral temperatures of a user's lower extremities, the user's weight, or the user's blood pressure.

[0051] The embodiment of the invention illustrated in **FIG. 4** is designed to be utilized if the person is seated or reclining. The device will monitor the temperature of the skin surface based upon the location data received from an array of pressure sensors contained within the blanket **210**. **FIG. 5** illustrates the embodiment of the invention which is designed to be utilized if the apparatus is to be positioned around an extremity wherein the temperature sensors will simply measure the temperature of the entire skin surface inside the wrap. Such system is particularly helpful for monitoring the healing of a small bone break or a sprain.

[0052] The apparatus and method of the present invention may also provide the foundation for a method of operating a health information monitoring business. Specifically, the sensed vital health information could be sent to a data storage facility and compared with past data or predetermined levels of vital health information. If this comparison yields an indication of a condition which is predictive of near term or future health problems, a health care professional may call the patient and recommend a consultation or treatment which may cure a nascent condition before life or limb-threatening symptoms are experienced. Such a vital health information monitoring system could be required for use by designated employees of an employer to reduce lost time maladies. Further, such a vital health information

monitoring system could also be required for use by life or health insurance companies to provide a basis for reassessing the risk that the insurance company will have to pay for the health care costs associated with an illness or malady or the face amount of a life insurance policy on the death of the insured. Such risk reassessment could be used to tailor premium rates to the health of individual insureds.

[0053] It will be understood by those of ordinary skill in the art that while the apparatus and method of the present invention has been described with respect to its preferred embodiment, those of ordinary skill in the art will understand the numerous other embodiments of this invention may be possible without departing from the foregoing teachings. Such other embodiments shall be included within the scope and meaning of the appended claims.

What is claimed is:

1. An apparatus for monitoring the temperature of the plantar aspects of the foot of a human being, said device comprising:

a grid having a plurality of holes therein at predetermined locations;

a movable array of light sensors and skin temperature sensors;

said movable array of light sensors and skin temperature sensors constructed and arranged to travel under said grid and produce signals representative of the location of the feet and the skin temperatures on the plantar aspects of feet through said holes in said grid;

computer means for receiving said signals representative of the location of the feet and the skin temperatures on the plantar aspects of the feet;

said computer means constructed and arranged to both determine the position of the feet with respect to said holes in said grid using said signals representative of the location of the feet and the temperatures on the plantar aspects of the feet and selecting certain of such holes for recording sensed skin temperatures;

means for displaying said recorded skin temperatures.

2. The apparatus as defined in claim 1 further including means for generating a warning if a temperature exceeding a predetermined level as between two or more similar locations on the feet or adjacent sites on one foot is sensed.

3. The apparatus as defined in claim 1 wherein said output of recorded temperatures is a visual output.

4. The apparatus as defined in claim 3 wherein said visual output is a liquid crystal display.

5. The apparatus as defined in claim 1 wherein said output of sensed temperatures is an audio output.

6. The apparatus as defined in claim 1 further including means for sensing and displaying the weight of the human being.

7. The apparatus as defined in claim 1 further including means for sensing and displaying the blood pressure of the human being.

8. The apparatus as defined in claim 1 further including means for sensing and displaying the pulse rate of the human being.

9. The apparatus as defined in claim 1 further including means for sensing and displaying the blood glucose levels of the human being.

10. The apparatus as defined in claim 1 further including means for sensing and displaying the blood oxygen levels of the human being.

11. The apparatus as defined in claim 1 further including a modem for transmitting the recorded foot temperatures to a remote location.

12. The apparatus as defined in claim 7 further including means for transmitting the sensed blood pressure to a remote location.

13. The apparatus as defined in claim 8 further including means for transmitting the sensed pulse rate to a remote location.

14. The apparatus as defined in claim 9 further including means for transmitting the sensed blood glucose level to a remote location.

15. The apparatus as defined in claim 10 further including means for transmitting the sensed blood oxygen level to a remote location.

16. A system for monitoring the temperatures of the plantar aspects of the feet of a plurality of patients, said system comprising:

a grid having a plurality of holes formed therein, said holes being located at predetermined locations;

a movable array of light sensors;

said movable array of light sensors constructed and arranged to travel under said grid and produce signals indicating the location of the patient's feet through said holes in said grid;

a movable array of skin temperature sensors;

said movable array of skin temperature sensors constructed and arranged to travel under said grid and produce signals representative of the skin temperatures on the plantar aspects of the patient's feet through said holes in said grid;

a computer for receiving said signals representative of said location of the patient's feet and said skin temperatures on the plantar aspects of the patient's feet;

said computer constructed and arranged to both determine the position of patients' feet with respect to said holes in said grid using said signals representative of said location of the patient's feet and said skin temperatures on the plantar aspects of the feet and selecting certain of said holes for recording sensed temperatures;

means for converting said signals generated by said heat sensitive probes into an output expressed in terms of temperature;

means for sending said signals to a remote location;

means for storing and analyzing said signals at said remote location;

whereby the temperatures of the feet of a plurality of human beings may be monitored at said remote location.

17. The system as defined in claim 16 wherein said means for sending said signals to a remote location is a telephone modem.

18. The system as defined in claim 16 wherein said means for sending said signals to a remote location is a wireless means.

19. The system as defined in claim 16 further including means for generating a warning if a temperature difference exceeding a predetermined level as between two or more of said probes is sensed.

20. The system as defined in claim 16 further including a visual display of sensed temperatures.

21. The system as defined in claim 19 further including means for generation of an audio warning.

22. The system as defined in claim 16 further including means for sensing and displaying the weight of a patient.

23. The system as defined in claim 16 further including means for sensing and displaying the blood pressure of a patient.

24. The system as defined in claim 16 further including means for sensing and displaying the pulse rate of a patient.

25. The system as defined in claim 16 further including means for sensing and displaying the blood glucose levels of a patient.

26. The system as defined in claim 16 further including means for sensing and displaying the blood oxygen levels of a patient.

27. The system as defined in claims 16, 22, 23, 24, 25, and 26 further including means for storing the sensed information along with the date and time when the information was sensed.

28. A health monitoring system comprising:

a grid having a plurality of holes therein at predetermined locations, said grid including a portion for the bottom of a patient's left foot and a portion for the bottom of a patient's right foot;

a movable, substantially linear array of light sensors and infrared temperature sensors:

said movable, substantially linear array of light sensors and infrared temperature sensors, constructed and arranged to travel under said grid and produce signals representative of foot location and skin temperatures on the bottom of the patient's feet covering said holes;

at least one guide per foot for enabling registration of the physical position of a patient's foot with respect to said grid;

means for receiving and displaying the foot location signals using said movable, substantially linear array of light sensors

means for receiving and displaying the skin temperatures on the bottom of the patient's feet using said movable, substantially linear array of infrared sensors.

29. A method for monitoring the temperature at predetermined locations on the feet of a human being, said method comprising the steps of:

locating the position of the feet on the top surface of a grid plate; and

sensing the skin temperatures of the predetermined locations on the bottom of the feet beneath the bottom surface of said grid plate.

30. The method of claim 29, wherein the step of locating the position of the feet on a grid plate further includes:

sensing the position of the feet on said grid plate using an array of light sensors;

whereby said light sensors are constructed and arranged to detect light shining through holes in said grid plate.

31. The method of claim 29, wherein the step of sensing the skin temperatures of the predetermined locations on the bottom of the feet further includes:

sensing the skin temperatures at predetermined locations on the bottom of a patient's feet using an array of temperature sensors;

whereby said temperature sensors are constructed and arranged to measure skin temperature through said holes in said grid plate.

32. A method for monitoring the temperature of a skin surface, said method comprising the steps of:

placing a blanket having a plurality of holes therein under a patient's skin surface;

said blanket constructed and arranged wherein an array of pressure and temperature sensors are positioned beneath said plurality of grid holes;

determining the location of the patient's skin surface with respect to said blanket by signals produced by said pressure sensors;

determining the temperature of the patient's skin surface which touches said blanket by signals produced by said temperature sensors;

transmitting said signals representative of said temperature of the patient's skin on a computer;

displaying, recording, and transmitting said recorded signals to a remote location.

33. A method for monitoring the temperature of an extremity of an animal, said method comprising the steps of:

placing a wrap having a plurality of holes therein around the extremity of an animal;

said wrap constructed and arranged wherein an array of temperature sensors are positioned beneath said plurality of holes;

determining the temperature of the skin surface of the animal's extremity which touches said wrap by signals produced by said temperature sensors;

transmitting said signals representative of said temperature of the skin surface of the animal's extremity to a computer;

displaying, recording, and transmitting said recorded signals to a remote location.

34. A method of monitoring the health of an employed human being comprising the steps of:

a) repeatedly sensing the temperatures on the bottoms of the human being's feet;

b) repeatedly sensing at least one other health indicator selected from a group including: body weight, blood pressure, pulse rate, blood glucose level, and blood oxygen level;

c) transmitting said temperatures on the bottoms of a human being's feet and said at least one health indicator to the employer;

- d) comparing said temperatures on the bottoms of a human being's feet and said at least one health indicator to other like items of health information sensed on prior occasions;
- e) alerting the employed human being of a potential health problem.

35. A method of monitoring the health of an insured or inclusion or covered plan human being comprising the steps of:

- a) repeatedly sensing the temperatures on the bottom of the feet;

- b) repeatedly sensing at least one other health indicator selected from a group including: body weight, blood pressure, pulse rate, blood glucose level, and blood oxygen level;
- c) transmitting said temperatures on the bottom of the human being's feet and said at least one health indicator to the insurer;
- d) comparing said temperatures on the bottom of a human being's feet and said at least one health indicator to other like items of health information sensed on prior occasions;
- e) re-evaluating the insurance risk of the insured human being based on the sensed health information.

* * * * *

专利名称(译)	足部温度和健康监测系统		
公开(公告)号	US20020082486A1	公开(公告)日	2002-06-27
申请号	US10/029043	申请日	2001-12-20
[标]申请(专利权)人(译)	LAVERY劳伦斯 AGRAWALçMAULI ATHANASIOU KYRIACOS一个 康斯坦丁尼GEORGE P 兰多特丹R ZAMORANO RUBEN摹		
申请(专利权)人(译)	LAVERY LAWRENCE A. C. AGRAWAL MAULI ATHANASIOU KYRIACOS A. 康斯坦丁尼GEORGE P. 兰多特DAN R. ZAMORANO RUBEN G.		
当前申请(专利权)人(译)	SALIX MEDICAL , INC.		
[标]发明人	LAVERY LAWRENCE A AGRAWAL C MAULI ATHANASIOU KYRIACOS A CONSTANTINIDES GEORGE P LANCTOT DAN R ZAMORANO RUBEN G		
发明人	LAVERY, LAWRENCE A. AGRAWAL, C. MAULI ATHANASIOU, KYRIACOS A. CONSTANTINIDES, GEORGE P. LANCTOT, DAN R. ZAMORANO, RUBEN G.		
IPC分类号	A61B5/00 A61B5/01 A61B5/022 A61B5/024		
CPC分类号	A61B5/01 A61B5/015 A61B5/022 Y10S128/92 A61B5/145 A61B5/14532 A61B5/024		
其他公开文献	US6767330		
外部链接	Espacenet USPTO		

摘要(译)

本发明提供了一种用于监测人或动物体上预定位置的皮肤温度的装置和方法。一个实施例包括具有网格的平台，网格包括用户站在其上的孔。栅格下方是可移动的光传感器阵列和温度传感器。脚位置由光传感器的输出确定。皮肤表面上预定位置的温度由从温度传感器获得的信号确定。可以通过设备上的其他传感器获得额外的重要健康信息。可以存储数据以供将来检索，或者将数据发送到远程位置以进行非现场监视。替代实施例包括传感器毯或包裹物，由此温度传感器监测毯子上的压力区域或包裹物覆盖的区域的皮肤温度。

