



US006671530B2

(12) **United States Patent**
Chung et al.

(10) **Patent No.:** **US 6,671,530 B2**
(45) **Date of Patent:** ***Dec. 30, 2003**

(54) **POSITIONING METHOD FOR PULSE OXIMETRY FETAL SENSOR**

(75) Inventors: **Christopher Chung**, Pleasanton, CA (US); **Helen M. McNamara**, Leeds (GB)

(73) Assignee: **Nellcor Puritan Bennett Incorporated**, Pleasanton, CA (US)

(*) Notice: Subject to any disclaimer, the term of this patent is extended or adjusted under 35 U.S.C. 154(b) by 0 days.

This patent is subject to a terminal disclaimer.

(21) Appl. No.: **10/080,500**

(22) Filed: **Feb. 21, 2002**

(65) **Prior Publication Data**

US 2002/0137996 A1 Sep. 26, 2002

Related U.S. Application Data

(60) Continuation of application No. 09/306,476, filed on May 6, 1999, now Pat. No. 6,370,409, which is a continuation of application No. 08/954,303, filed on Oct. 20, 1997, now Pat. No. 5,961,452, which is a continuation of application No. 08/406,761, filed on Mar. 17, 1995, now Pat. No. 5,743,260, which is a continuation of application No. 08/094,632, filed on Jul. 19, 1993, now abandoned, which is a division of application No. 07/598,850, filed on Oct. 15, 1990, now Pat. No. 5,228,440.

(30) **Foreign Application Priority Data**

Aug. 22, 1990 (EP) 90309180

(51) **Int. Cl.**⁷ **A61B 5/00**

(52) **U.S. Cl.** **600/338**

(58) **Field of Search** 600/338, 310, 600/313, 322, 323, 339, 341, 342, 344

(56) **References Cited**

U.S. PATENT DOCUMENTS

3,167,658 A 1/1965 Richter
3,326,207 A 6/1967 Egan

(List continued on next page.)

FOREIGN PATENT DOCUMENTS

CA 671279 10/1963
DE 2517129 B 6/1976
DE 1909882 B 11/1976
DE 2830412 A 1/1980
DE 3327561 A1 3/1984
DE 3810008 C1 10/1989

(List continued on next page.)

OTHER PUBLICATIONS

Goodlin, R. C., "Care of the Fetus," pp. 101-110, Masson Publishing USA, Inc., (1979).

Goodlin et al., "A New Fetal Scalp Electrode," *Obstetrics & Gynecology*, 35(4):646-647 (1970).

Goodlin et al., "Systolic Time Intervals in the Fetus and Neonate," *Obstetrics & Gynecology*, 39(2): (1972).

Goodlin et al., "Intrapartum fetal heart rate responses and plethysmographic pulse," *Am. J. of Obstetrics & Gynecology*, 110(2):210-226 (1971).

(List continued on next page.)

Primary Examiner—Eric F. Winakur

(74) *Attorney, Agent, or Firm*—Townsend and Townsend and Crew, LLP

(57) **ABSTRACT**

An intrauterine pulse oximetry apparatus and method are provided to measure fetal blood oxygen saturation at sites in a preferred region on the fetus. The sensor of the apparatus is attached to a stiff cable which can be inserted into the uterus past the presenting part and transcervical region of the fetus. The cable may have visual and tactile markings by which the user, without seeing or feeling the sensor, can guide it to an appropriate site on the fetus.

8 Claims, 6 Drawing Sheets

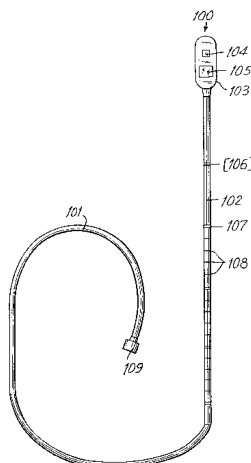

U.S. PATENT DOCUMENTS

3,402,717	A	9/1968	Doherty	
3,599,629	A	8/1971	Gordy	
3,602,213	A	8/1971	Howell et al.	
3,647,299	A	3/1972	Lavallee	
3,659,586	A	5/1972	Johns et al.	
3,704,706	A	12/1972	Herczfeld et al.	
3,769,974	A	11/1973	Smart et al.	
3,827,428	A	8/1974	Hon et al.	
3,841,314	A	10/1974	Page	
3,983,866	A	10/1976	Ulrich et al.	
4,013,067	A	3/1977	Kresse et al.	
4,041,932	A	8/1977	Fostick	
4,091,803	A	5/1978	Pinder	
4,136,681	A	1/1979	Hon	
4,197,853	A	4/1980	Parker	
4,244,375	A	1/1981	Farrar et al.	
4,281,659	A	8/1981	Farrar et al.	
4,324,256	A	4/1982	Vesterager	
4,350,165	A	9/1982	Striese	
4,370,984	A	2/1983	Cartmell	
4,396,017	A	8/1983	Delpy et al.	
4,502,490	A	3/1985	Evans et al.	
4,537,197	A	8/1985	Hulka	
4,543,965	A	10/1985	Pack et al.	
4,600,015	A	7/1986	Evans et al.	
4,658,825	A	4/1987	Hochberg et al.	
4,697,593	A	10/1987	Evans et al.	
4,718,423	A	1/1988	Willis et al.	
4,722,730	A	2/1988	Levy et al.	
4,856,527	A	8/1989	Karcher et al.	
4,873,986	A	10/1989	Wallace	
4,878,898	A	11/1989	Griffin et al.	
4,938,218	A	7/1990	Goodman et al.	
4,981,470	A	1/1991	Bombeck, IV	
5,024,226	A	6/1991	Tan	
5,025,787	A	6/1991	Sutherland et al.	
5,099,842	A	3/1992	Mannheimer et al.	
5,109,849	A	5/1992	Goodman et al.	
5,135,006	A	8/1992	Bellinson	
5,154,175	A	10/1992	Gunther	
5,218,962	A	6/1993	Mannheimer et al.	
5,228,440	A	7/1993	Chung et al.	
5,247,932	A	9/1993	Chung et al.	
5,361,757	A	11/1994	Smith et al.	
5,377,675	A	1/1995	Ruskewicz et al.	
5,411,024	A	5/1995	Thomas et al.	
5,743,260	A	4/1998	Chung et al.	
5,961,452	A	10/1999	Chung et al.	
6,370,409	B1 *	4/2002	Chung et al.	600/338

FOREIGN PATENT DOCUMENTS

DE	4304693	A1	8/1994
EP	0 001 293	A1	9/1978
EP	0 072 185	B1	2/1983
EP	0 094 749	A2	11/1983
EP	0 135 840	A2	4/1985
EP	0 303 756	A2	2/1989
EP	0 149 866	B1	4/1989
EP	0 104 619	B1	9/1991
EP	0 502 861	B1	1/1996

GB	2 216 804	A	10/1989
JP	61-139204	A	8/1961
JP	48-057495	A	8/1973
JP	49-132679	A	11/1974
JP	49-002729	A	1/1984
JP	49-040286	A	7/1984
JP	60-006504	A	1/1985
JP	61-143033	A	6/1986
JP	61-168338	A	7/1986
JP	61-139203	A	8/1986
JP	63-034412	A	3/1988
JP	63-105740	A	5/1988
JP	63-172406	A	11/1988
JP	63-288142	A	11/1988
JP	64-056031	A	3/1989
JP	1-175834	A	6/1989
JP	1-112809	A	7/1989
JP	1-285243	A	11/1989
JP	2-104014	A	8/1990
JP	2-111413	A	9/1990
JP	2-126614	A	10/1990
JP	3-21223	A	1/1991
JP	4-7806	A	1/1992
JP	4-54953	A	2/1992
JP	4-244144	A	9/1992
JP	4-317640	A	11/1992
SU	584844	A	12/1977
WO	WO 88/02616	A1	4/1988
WO	WO 89/09566	A1	10/1989
WO	WO 90/01293	A1	2/1990
WO	WO 90/04352	A1	5/1990
WO	WO 91/07910	A1	6/1991
WO	WO 91/15996	A1	10/1991

OTHER PUBLICATIONS

Jobsis, F. F., "Noninvasive, Infared Monitoring of Cerebral and Myocardial Oxygen Sufficiency and Circulatory Parameters," *Science*, 198(4323): 1264-1267 (1977).

Seeds et al., "The relationship of intercranial infared light absorbance to fetalm oxygenation," *Am. J. of Obstetrics & Gynecology*, 149(6):679-684 (1984).

Seeds et al., Near Infared Spectrophotometry: A New Technique for Assessing Fetal Hypoxia, *Surgical Forum—Gynecology & Obstetrics*, 1984.

Viniker, D. A., "The Fetal EEG (detection of oxygen deprivation)," *British Journal of Hospital Medicine*, 22(5):504-5-7, 509-510 (1979).

Weller et al., "Fetal Electroencephalography Using a New Flexible Electrode," *British J. of Obstetrics and Gynaecology*, 88(10):983-986 (1981).

Data Sheet, "Silicon Diffused Pin Photodiodes—SGD Series," EG&G Electro-Optics, Sheet D3003C-5.

Data Sheet No. 9F002, "Planar Diffused Silicon Pin Photodiodes," United Detector Technology, Hawthorne, CA.

Data Sheet B400-44-004, Rev. B, 1-3 "General Purpose Detectors," Dilicon Dectector Corporation, Newbury Park, CA.

* cited by examiner

FIG. 1

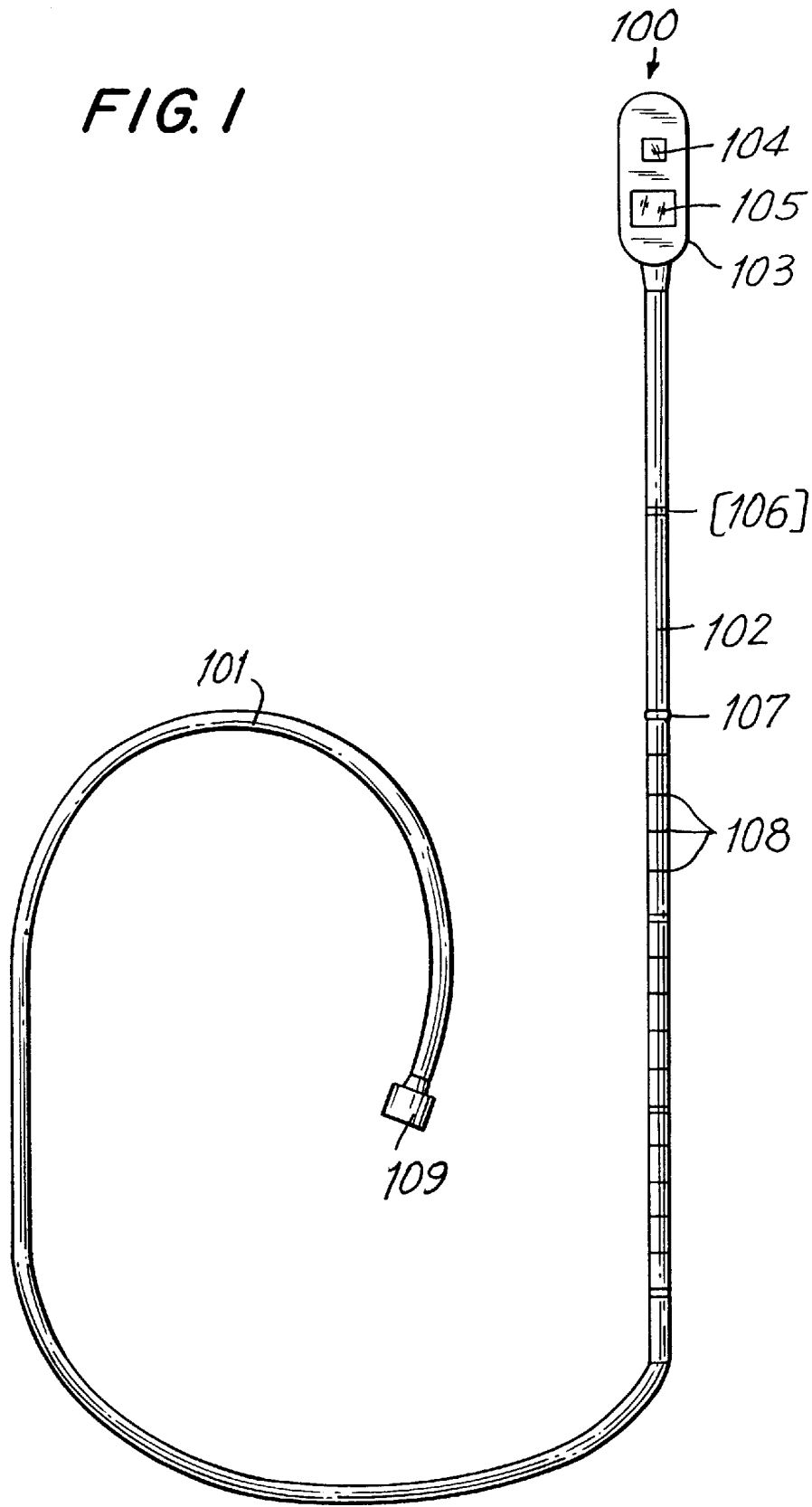

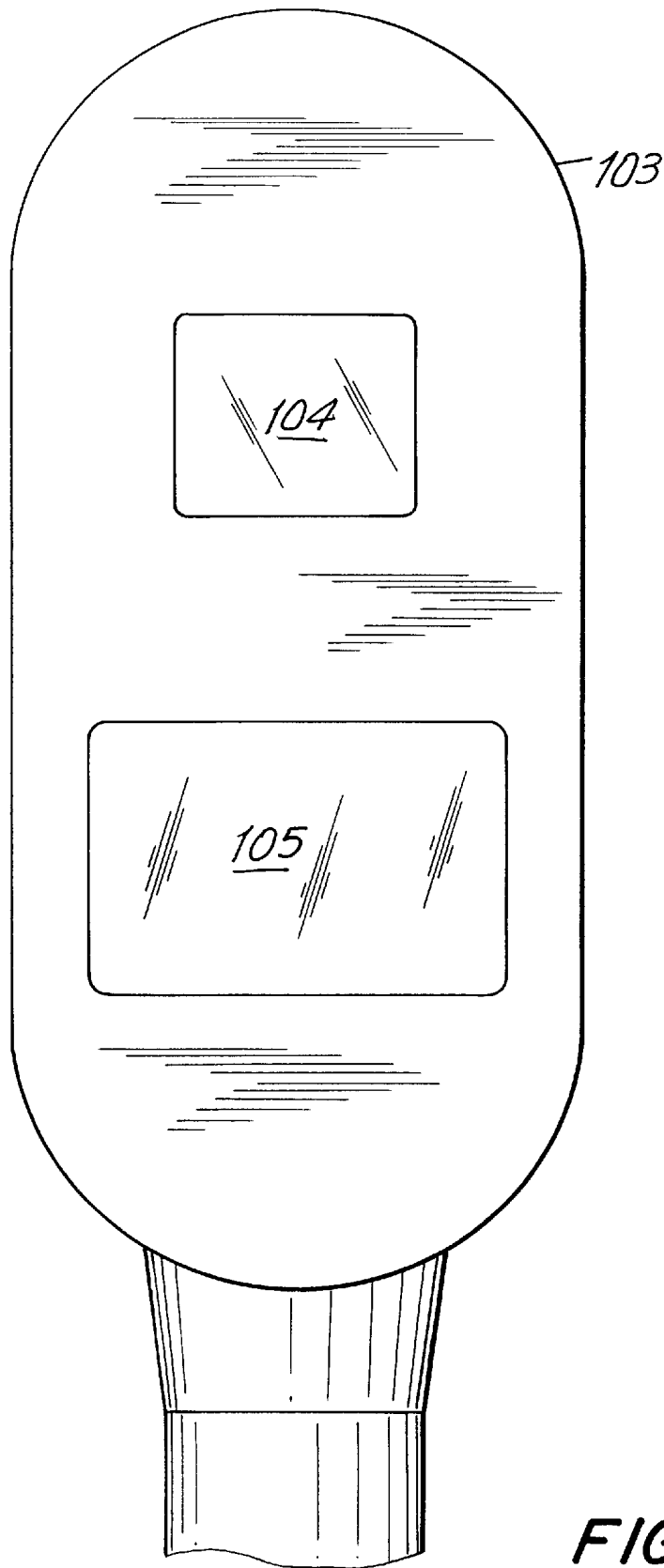

FIG. 2

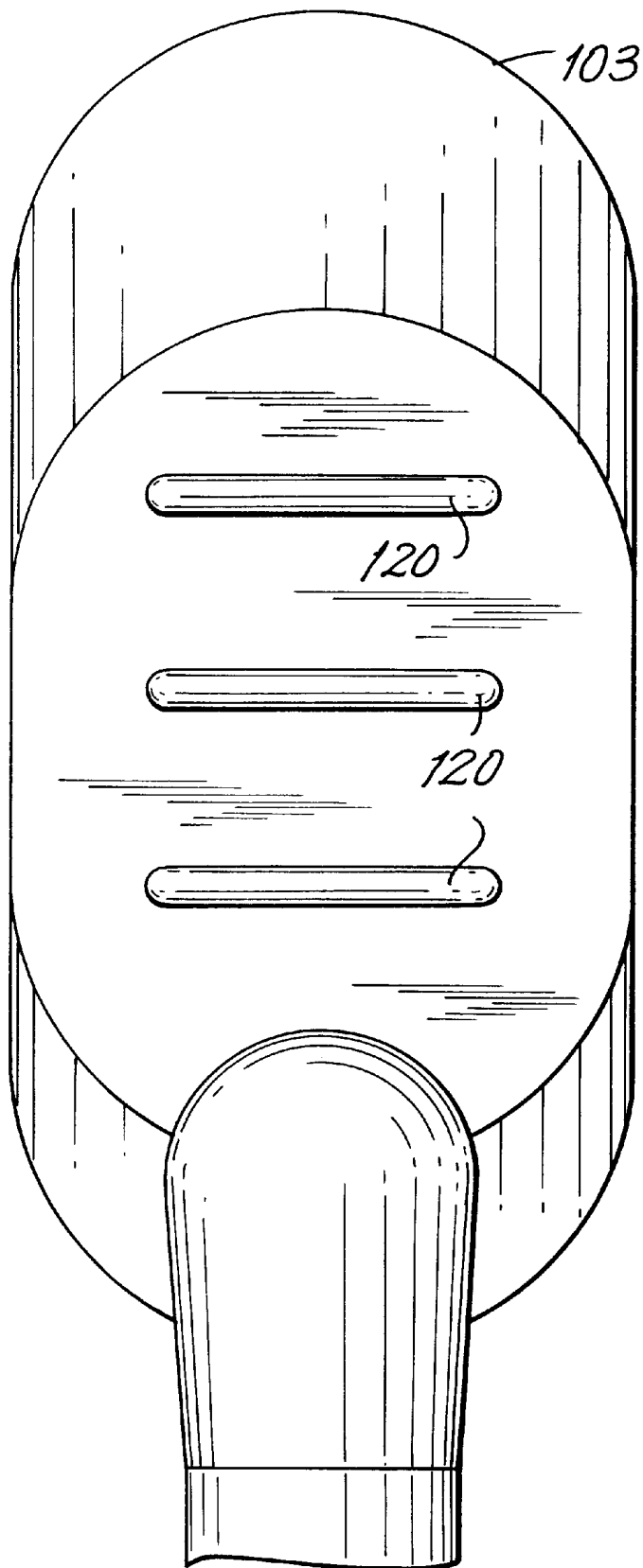

FIG. 3

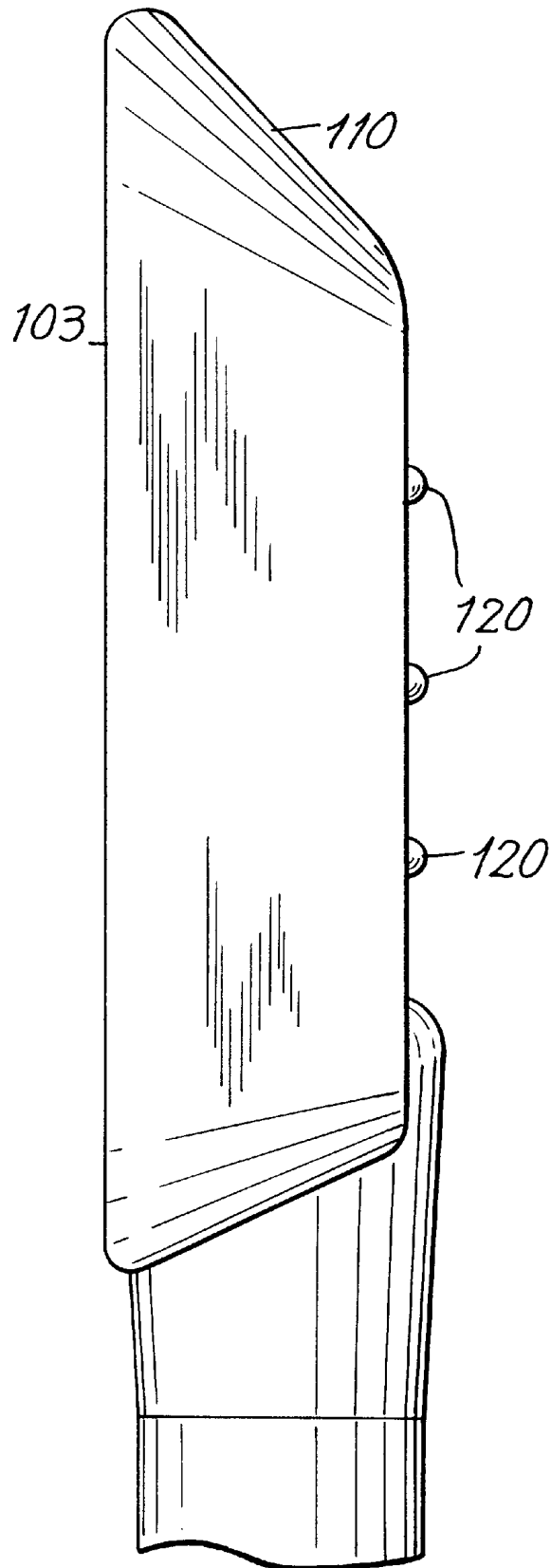

FIG. 4

FIG. 5

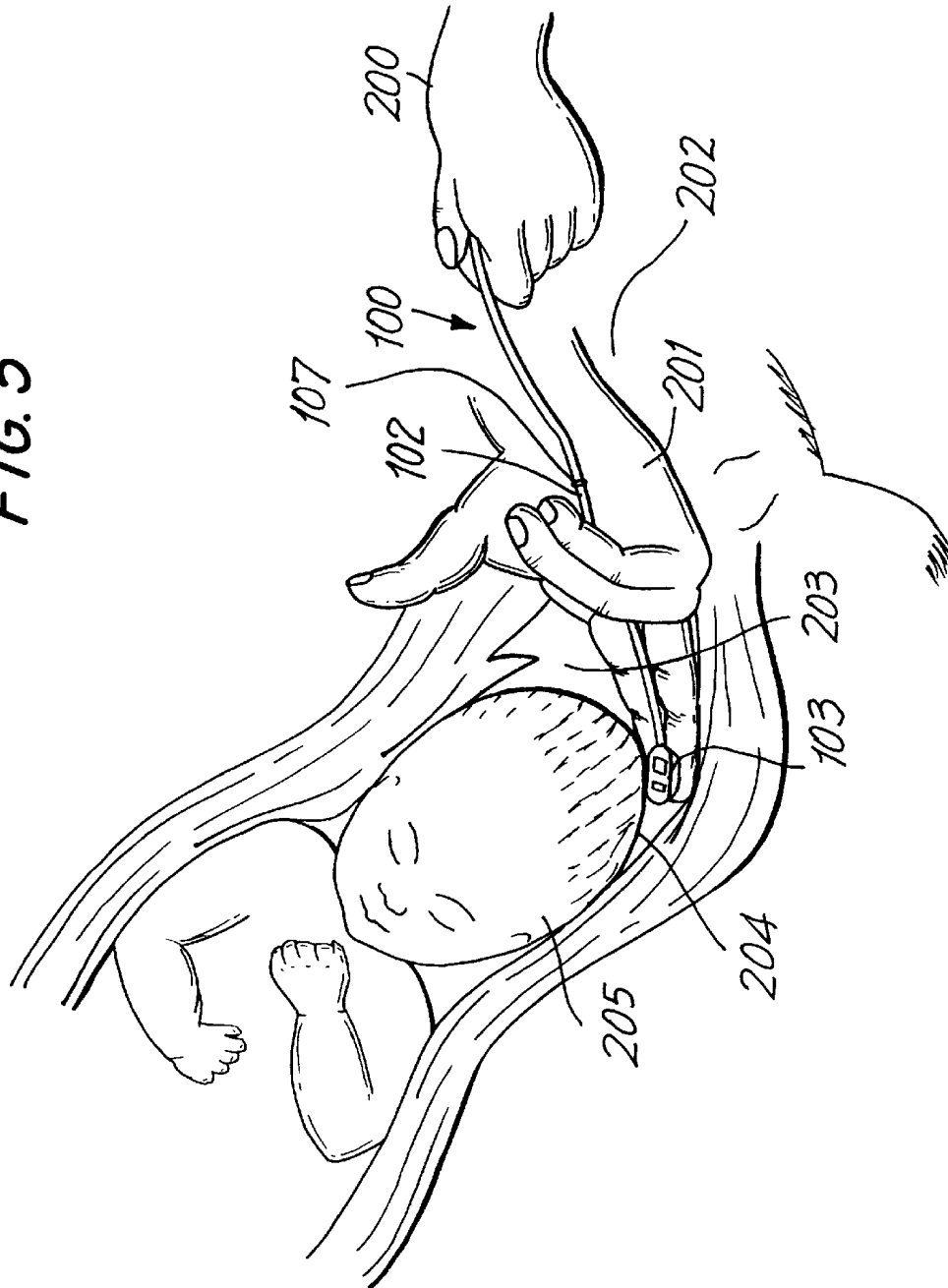

FIG. 6

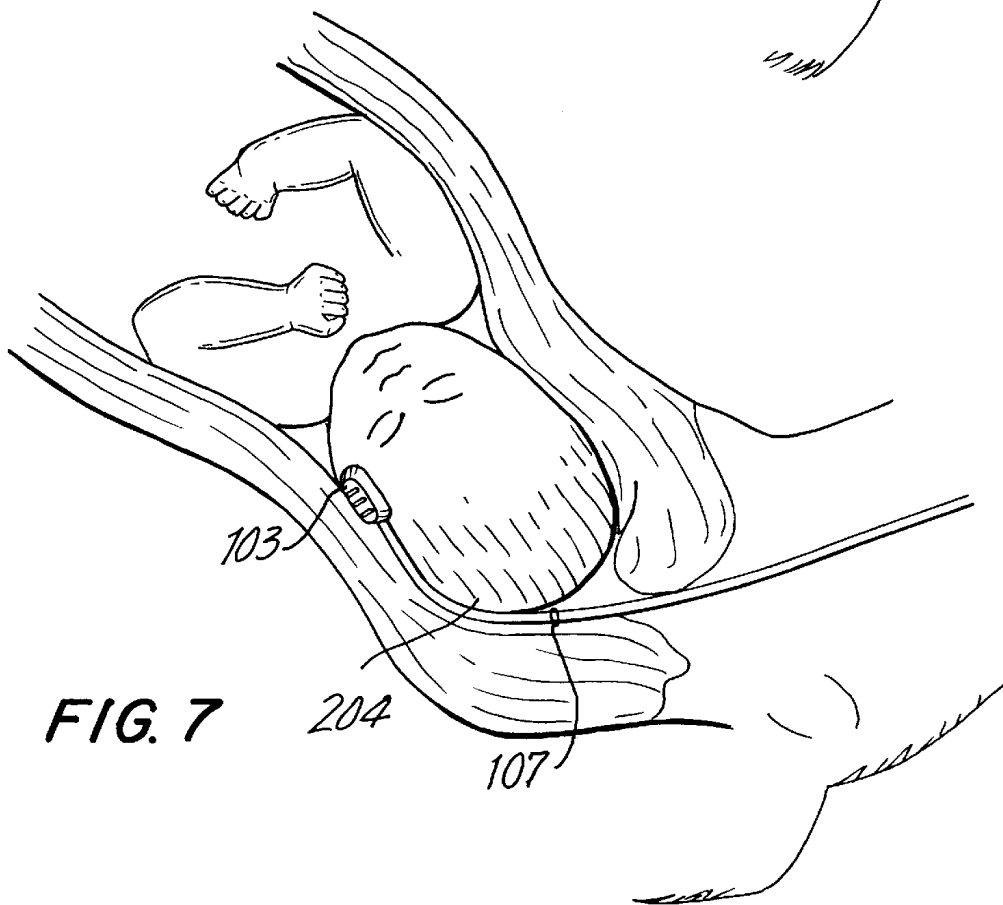
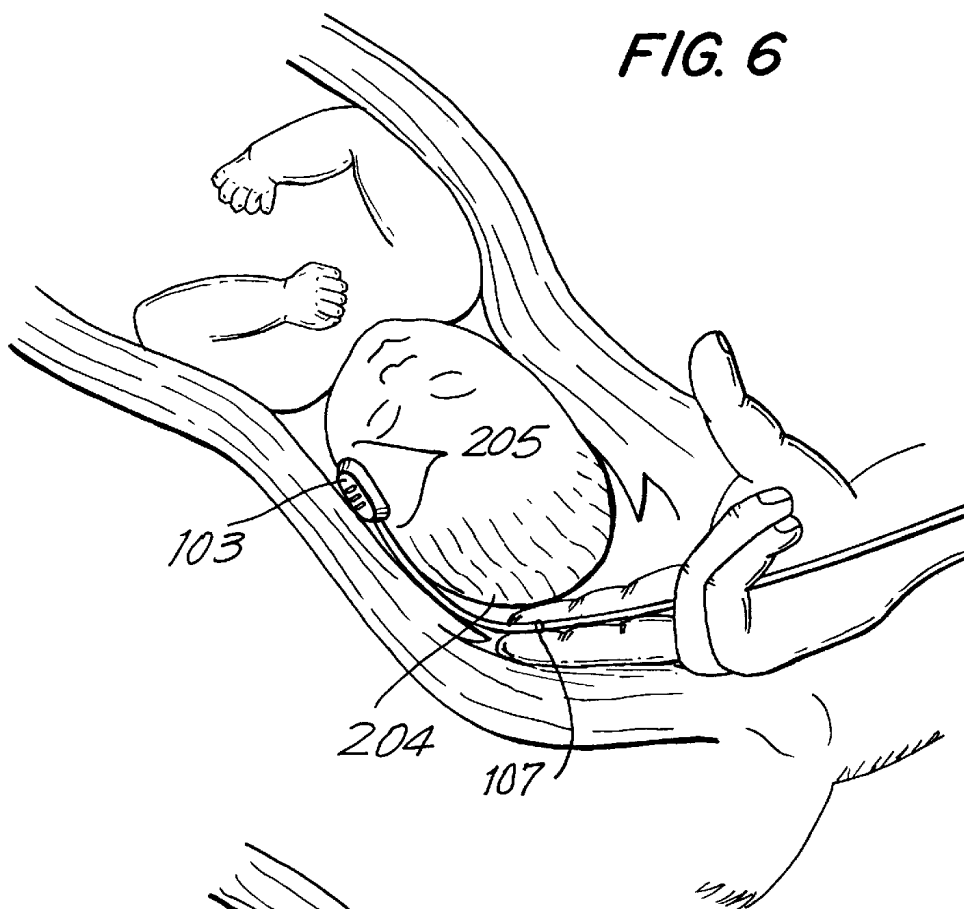

FIG. 7

POSITIONING METHOD FOR PULSE OXIMETRY FETAL SENSOR

CROSS-REFERENCE TO RELATED APPLICATIONS

This is a continuation of U.S. application Ser. No. 09/306,476 filed May 6, 1999, now U.S. Pat. No. 6,370,409; which is a continuation of U.S. application Ser. No. 08/954,303 filed Oct. 20, 1997, now U.S. Pat. No. 5,961,452; which is a continuation of Ser. No. 08/406,761 filed Mar. 17, 1995, now U.S. Pat. No. 5,743,260; which is a continuation of U.S. application Ser. No. 08/094,632 filed Jul. 19, 1993, now abandoned; which is a divisional of U.S. application Ser. No. 07/598,850 filed Oct. 15, 1990, now U.S. Pat. No. 5,228,440; which corresponds to European Application No. EP 90309180, filed Aug. 22, 1990, which disclosures are incorporated herein by reference.

BACKGROUND OF THE INVENTION

This invention relates to an intrauterine pulse oximetry apparatus and method for measuring fetal oxygen saturation during labor and delivery. The invention particularly relates to placing the apparatus within a preferred region on the fetus.

A fetal pulse oximetry apparatus may include a sensor attached to an electrical cable. The sensor, which contains a light source and a light detector, is placed on the fetus. The cable connects the sensor to a pulse oximeter. Light from the light source is transmitted through the fetal tissue and reflected back to the light detector. The amount of light received by the light detector depends on characteristics of the blood in the fetal tissue, among other things.

Fetal pulse oximetry sensors are not new. Some previous apparatus were physically attached to the fetal skin by hooks, spirals, suction, or glue. One example is the fetal pulse oximetry sensor disclosed in PCT Publication No. WO 90/01293. These attachment means were invasive or potentially harmful. Therefore the apparatus were placed only in fetal regions that the doctor or other user could reach with his or her fingers, such as on the presenting part of the fetus or on the fetus within the uterine region just beyond the cervix (the "transcervical region").

The structure of previous apparatus did not permit safe and accurate placement on the fetus in the region beyond the reach of the user. In addition, nothing was known of fetal pulse characteristics in this region. Thus placement of the apparatus beyond the presenting part or in the transcervical region was considered undesirable.

SUMMARY OF THE INVENTION

Our tests have shown that fetal pulses are stronger in the region on the fetus beyond the presenting part and beyond the transcervical region. We call this fetal region the "preferred region." The present invention monitors pulses in the preferred region.

In a vertex presentation (the fetus descending headfirst), cervical pressure on the presenting part creates local edema (caput) which can suppress the fetal pulse and make pulse oximetry readings unreliable. The amplitude of the pulse in the presenting part also will change as the cervix dilates and changes the local force on the vertex.

During the periodic contractions of the uterine wall, additional local forces on the presenting part of the fetus are exerted actively by the cervix and passively by the pelvic bones. These transient local forces may further affect pulse

amplitude. Thus, obtaining strong and consistent pulses throughout labor and delivery may be difficult.

The readings also may be affected by fetal hair. Depending on its color and amount, hair attenuates the light to various extents. Hair also may cause light to be shunted from the light source to the light detector, which adversely affects the measurement.

The present invention overcomes some of the shortcomings of previous fetal pulse oximetry apparatus and their placement methods. It provides an apparatus and a method of placing it in the preferred region, i.e. on the fetus beyond the presenting part and beyond the transcervical region. Pulse amplitudes in the preferred region are not affected by caput. They are less affected by cervical and pelvic bone forces than in the presenting part or the transcervical region. Since there is less hair (or even no hair) in the preferred region, the light transmission to and from the fetal tissue will be less attenuated and less susceptible to shunting. The apparatus and method allow the user to place the sensor without damaging the sensitive fetal eyes and fontanelles.

The preferred embodiment of the apparatus provides an electrical cable having a stiffer part adjacent to the sensor. This stiff part of the cable can be used to guide the sensor into position. The stiff part of the cable is rigid enough to be guided through the vagina and cervix without an introducer. It is flexible enough to yield when the sensor encounters an obstruction such as the uterine wall. With the sensor in position, the stiff part of the cable bends around the fetal head and conforms to the mother's pelvic curve. This conformance allows prolonged application of the sensor without discomfort to the mother.

The stiff part of the cable has calibrated visual markings and one or more tactile markings (ridges). The visual markings are particular distances from the leading edge of the sensor. The ridge is located at a position approximating the distance from the vertex of the fetal head to a site well within the preferred region on a fetus at term. The ridge may coincide with one of the visual markings.

Devices inserted into the mother's uterus must be sterile to avoid infection. As in prior art, the user must manipulate the apparatus within the vagina to place the sensor. If a prior-art device failed, the user would have to perform an additional vaginal examination to remove it. It would have to be sterilized before being reapplied. It also could be reapplied only with an introducer. If sterilizing were impractical, a new device would have to be used.

The current apparatus overcomes these limitations. If the sensor does not perform properly in its initial placement, the user can grasp the exposed stiff part of the cable and insert or withdraw it a small amount, for example 1 cm, as indicated by the visual markings. This action will reposition the sensor on a new site within the preferred region of the fetal head without removing the sensor from the uterus.

The method of using the apparatus has many advantages over prior art. It does not reintroduce anything into the vagina. Pulse oximetry readings thus can be taken without re-sterilizing the apparatus, outfitting it with an introducer, or using a new apparatus. The method typically is painless for the mother: it does not require uncomfortable manipulation of the apparatus inside the vagina. The method can be repeated during labor as necessary, for optimal sensor performance.

With the stiff part of the cable the user also can monitor the station of the fetal head (the position of the fetal head within the mother's pelvis). Fetal head station is important to evaluate the progression of labor. It is determined by

internal examination, which assesses the position of the fetal head relative to the pelvic spines. The apparatus and method of the current invention permit the user to continuously assess this position without frequent repeated internal examinations.

As the fetal head descends during labor, the sensor descends with it. If the user notes the station of the fetal head when the sensor is initially placed, the station can be correlated with the amount of the stiff part of the cable protruding from the vagina. The visual markings indicate how much of the stiff part is exposed. The exposed stiff part of the cable will represent the station of the fetal head.

One skilled in the art will recognize that the apparatus could operate as a fetal station indicator without using the oximetry sensor so long as some means is provided of placing the inner end of the tube against the fetus within a preselected region. A trailer extending from the inner end of the indicator through the mother's vagina would have visual markings correlating to the station of the fetal head.

The objects of the invention are as follows:

To obtain improved pulse oximetry readings by measuring fetal oxygen saturation in a region with stronger pulses.

To obtain improved pulse oximetry readings by measuring fetal oxygen saturation in a region less affected by caput, cervical pressures, and hair.

To obtain the improved readings safely, that is without injuring the fetus or the mother.

To obtain the readings comfortably for the mother.

To allow prolonged yet comfortable and accurate monitoring of the fetus.

To orient the apparatus effectively without seeing or ultimately feeling the sensor, since the sensor's target is beyond the reach of the user.

To reposition the sensor in the preferred region without withdrawing the apparatus from the uterus.

When repositioning, to avoid re-sterilizing the apparatus.

When repositioning, to avoid using an introducer.

When repositioning, to avoid using a new (sterile) apparatus.

When repositioning, to avoid causing discomfort to the mother.

To determine the station of the fetal head during labor without repeated internal examinations.

BRIEF DESCRIPTION OF THE DRAWINGS

In all drawings, like parts are designated by like reference numbers.

FIG. 1 is an overall view of the apparatus of the invention.

FIG. 2 is a view of the active side of the sensor, showing the light source and light detector.

FIG. 3 is a view of the inactive side of the sensor.

FIG. 4 is a cross-section of the sensor.

FIGS. 5 through 7 show the method of the invention. FIG. 5 shows the user inserting the apparatus into the vagina. FIG. 6 shows the user's hand guiding the sensor to the preferred region. FIG. 7 shows the sensor in place in the preferred region after the user removed his or her hand.

DETAILED DESCRIPTION OF THE EMBODIMENTS

The preferred embodiment of the apparatus is shown in FIG. 1. Apparatus **100** includes a sensor **103** and an elec-

trical cable **101** with a connector **109**. The electrical cable has a stiffer part **102** adjacent to the sensor. The stiffer part of the cable is rigid enough to be guided unsupported through the vagina and cervix and flexible enough to yield when the sensor encounters an obstruction such as the uterine wall.

In the preferred embodiment, a part of the cable is stiffened by enclosing it in a plastic tube. For example, the cable can be surrounded by shrink-tubing of an inner diameter of 0.25 cm and an outer diameter of 0.41 cm. To allow repositioning, this tube must be long enough, preferably 30 cm, to extend from the vagina when the sensor is in the preferred region.

The sensor **103** has one or more emitters (the light source(s)) **104** and detectors (the light detector(s)) **105**. The preferred embodiment has two emitters and a detector on one side, the active side, as shown in FIG. 2. In the preferred embodiment, the other or inactive side of the sensor has at least one tactile marking such as a bump or an indentation **120**, as shown in FIGS. 3 and 4. This marking helps the user properly orient the apparatus while inserting it into the vagina and through the cervix. The leading edge **110** of the sensor **103** is bevelled, as shown in FIG. 4, to facilitate introduction later in labor through a cervix that may be well-applied to (snug against) the fetal presenting part **204**.

The preferred embodiment of the cable **100** has a series of regularly spaced markings **108**. These markings provide a visual indication of the insertion depth of the sensor in the mother's vagina. In addition, a ridge **107** is formed on the cable at a predetermined distance from the leading edge **110** of the sensor **103**. The sensor is introduced until the ridge **107** is at the sagittal suture of the fetal head. The sensor is then in the preferred region **205**.

The method of using the apparatus is as follows. The user determines the location of the fetal back and the height and orientation of the fetal head by abdominal examination. The user then makes a vaginal assessment of cervical status using the Bishop score. This score grades the cervix on five elements: dilatation, effacement, position, station (of the fetal head: above, below, or at the ischial spine), and consistency (firm, soft, etc.). The vaginal examination also may precisely confirm the position of the fetal head.

With the examining fingers **201** already in the vagina **202** and at the posterior cervix **203**, the user grasps the apparatus **100** by the stiff part of the cable **102** with the other hand **200**. The sensor **103** is then inserted into the vagina with the active side up. It is then threaded up between the index and middle fingers **201** of the examining hand. The finger-tips of that hand feel for the bump or indentation **120** on the inactive side of the sensor **103**. See FIGS. 5, 6, and 7.

The fingers **201** of the examining hand stretch the posterior cervix **203** to make room for the sensor. The user further advances the sensor into the uterus past the presenting part and past the transcervical region. The sensor is then in the preferred region. For a fetus at term, the ridge **107** will be flush with the presenting part **204** when the sensor is in the preferred region, as in FIG. 6.

The user then removes his or her fingers from the vagina, leaving the sensor **100** in place, as in FIG. 7. If the readings from the initial placement are unsatisfactory, the sensor can be repositioned by slightly withdrawing or further inserting the stiff part of the cable **102**.

5

The preferred method of constructing the cable's features is as follows. Plastic tubing, such as polyolefin made by Raychem, is heat-shrunk over the area of the cable to become the stiff part. This first layer stiffens the cable. Regularly spaced markings are then drawn on the plastic tubing. In the preferred embodiment the markings are 1 cm apart, although any convenient marking scale can be used. The markings can take various forms, such as colors, characters, or numbers.

The ridge is formed by heat-shrinking a short segment of plastic tubing around this cable assembly at an appropriate location. In the preferred embodiment, the ridge is 15 cm from the leading edge of the sensor. That is the approximate distance from the vertex of a molded fetal head at term to the preferred region for the sensor. The ridge may be used as a visual marking as well by making it a different color from that of the cable.

After the ridge and the visual markings are applied to the cable, a clear plastic sheath is heat-shrunk over the cable assembly. The sheath smooths the edges of the ridge and protects the visual markings. It also further stiffens the cable.

We claim:

1. A fetal oximetry apparatus comprising:
a sensor for detecting oxygen saturation, said sensor being configured to contact a fetus without a positive attachment mechanism;

6

means for providing signals to and from the sensor; and means for accurately placing the sensor at a site on the fetus beyond the presenting part and beyond the transcervical region.

2. The apparatus of claim 1 wherein the means for placing comprises a substantially stiff tube.

3. The apparatus of claim 2 further comprising means for indicating the depth of insertion of the sensor into the vagina.

4. The apparatus of claim 3 wherein the means for indicating comprises visual markings on the tube.

5. The apparatus of claim 3 wherein the means for indicating comprises tactile markings on the tube.

6. The apparatus of claim 2 wherein the substantially stiff tube conforms to the pelvic curve.

7. The apparatus of claim 1 wherein the leading edge of the sensor is beveled.

8. The apparatus of claim 1 wherein the means for placing comprises means for stiffening, enabling the apparatus to remain straight enough under its own weight to be inserted unsupported into a vagina while bending slightly to avoid obstacles.

* * * * *

专利名称(译)	脉搏血氧仪胎儿传感器的定位方法		
公开(公告)号	US6671530	公开(公告)日	2003-12-30
申请号	US10/080500	申请日	2002-02-21
[标]申请(专利权)人(译)	内尔科尔普里坦贝内特公司		
申请(专利权)人(译)	NELLCOR PURITAN BENNETT, INC.		
当前申请(专利权)人(译)	NELLCOR PURITAN BENNETT INCORPORATED		
[标]发明人	CHUNG CHRISTOPHER MCNAMARA HELEN M		
发明人	CHUNG, CHRISTOPHER MCNAMARA, HELEN M.		
IPC分类号	A61B5/00 A61B5/107 A61B10/00 A61B5/145 A61B5/1455 A61B5/1464		
CPC分类号	A61B5/1076 A61B5/1464 A61B5/14542		
代理机构(译)	汤森和汤森和克鲁, LLP		
优先权	1990309180 1990-08-22 EP		
其他公开文献	US20020137996A1		
外部链接	Espacenet USPTO		

摘要(译)

提供一种子宫内脉搏血氧测定装置和方法，用于测量胎儿优选区域中的胎儿血氧饱和度。该装置的传感器连接到刚性电缆上，该电缆可以通过胎儿的呈现部分和经宫颈区域插入子宫中。电缆可以具有视觉和触觉标记，通过该标记，用户可以在不看到或感觉到传感器的情况下将其引导到胎儿上的适当部位。

