



US 20130184540A1

(19) **United States**

(12) **Patent Application Publication**
Boschetti Sacco et al.

(10) **Pub. No.: US 2013/0184540 A1**
(43) **Pub. Date: Jul. 18, 2013**

(54) **PORTABLE DEVICE FOR MONITORING AND REPORTING OF MEDICAL INFORMATION FOR THE EVIDENCE-BASED MANAGEMENT OF PATIENTS WITH CHRONIC RESPIRATORY DISEASE**

A61B 5/087 (2006.01)
A61B 5/1455 (2006.01)

(52) **U.S. Cl.**
CPC *A61B 5/4884* (2013.01); *A61B 5/14551* (2013.01); *A61B 5/1118* (2013.01); *A61B 5/087* (2013.01)
USPC **600/301**

(75) Inventors: **Paolo Boschetti Sacco**, Roma (IT); **Cesare Saltini**, Roma (IT); **Luigino Calzetta**, Roma (IT)

(73) Assignee: **MIR SRL-MEDICAL INTERNATIONAL RESEARCH**, Roma (IT)

(21) Appl. No.: **13/814,824**

(22) PCT Filed: **Aug. 9, 2010**

(86) PCT No.: **PCT/IT10/00361**

§ 371 (c)(1),
(2), (4) Date: **Apr. 3, 2013**

Publication Classification

(51) **Int. Cl.**
A61B 5/00 (2006.01)
A61B 5/11 (2006.01)

(57) **ABSTRACT**

An integrated tele-health system/device for monitoring and reporting medical information for the evidence-based management of patients with chronic respiratory disease. The device includes a central unit which measures and collects information related to the state of health of the patient, and is provided with elements for wireless or cable transmission of the collected data using a microprocessor based system with a touch screen display, USB communication port and Bluetooth. The device further includes: a removable sensor for the measurement of respiratory air flow and volume, a removable pulse oximetry sensor and a motion sensor. Stored data can be then delivered through landline, broadband, wireless and cell-phone technology to be received by a web server and can then be accessed by medical staff. Being completely portable, the device is provided with a battery of known type, which can be substituted by the user or can be rechargeable.

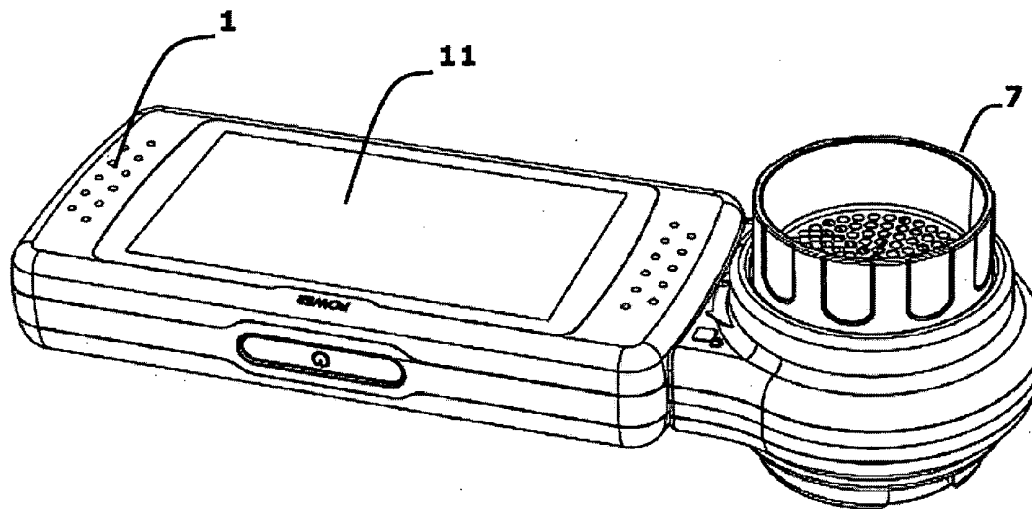

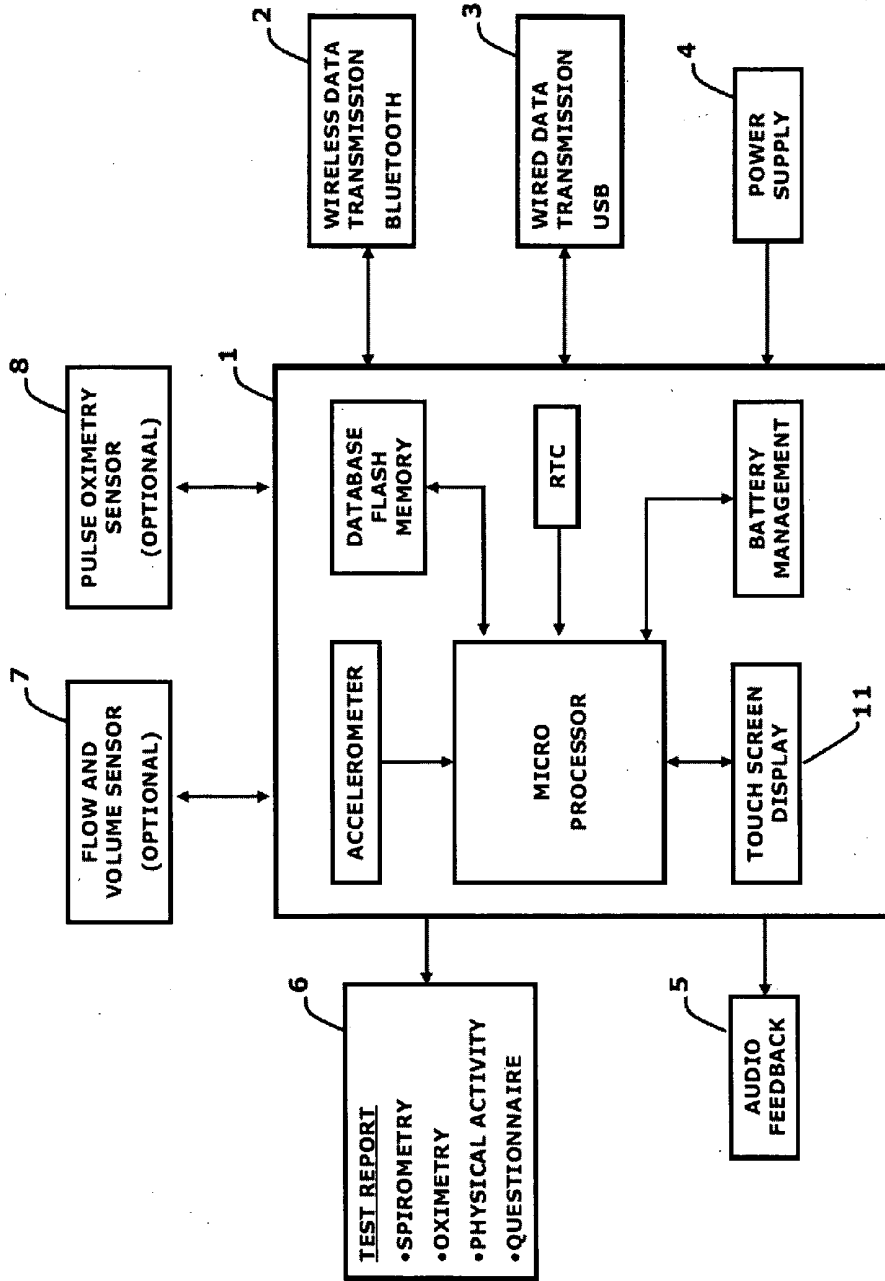

FIG. 1

tions, and for treatments of pulmonary conditions using the 6MWT for the calculation of the disease prognosis in a patient and for the evaluation of the results of a course of therapy in a patient.

* * * * *

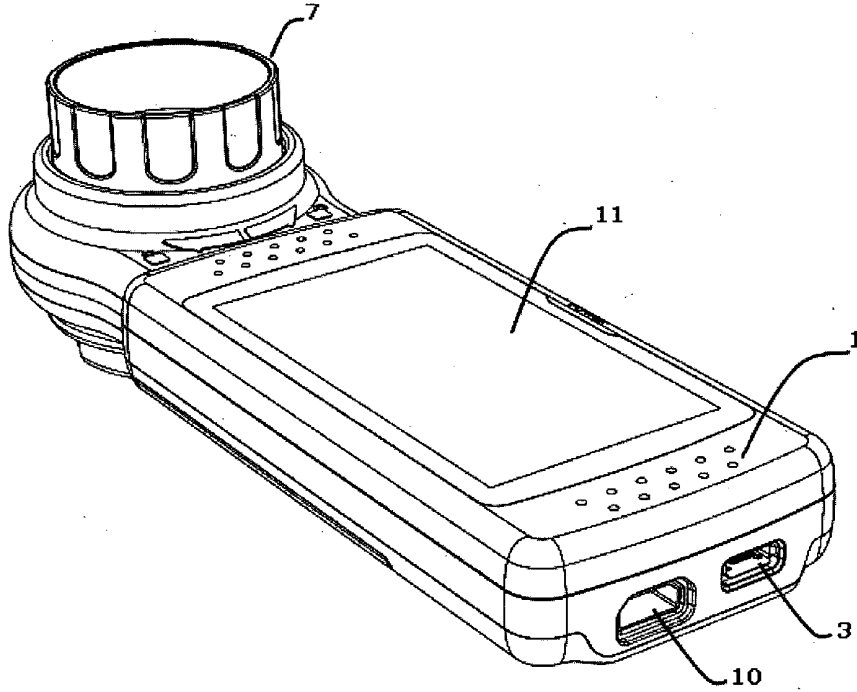

FIG. 2

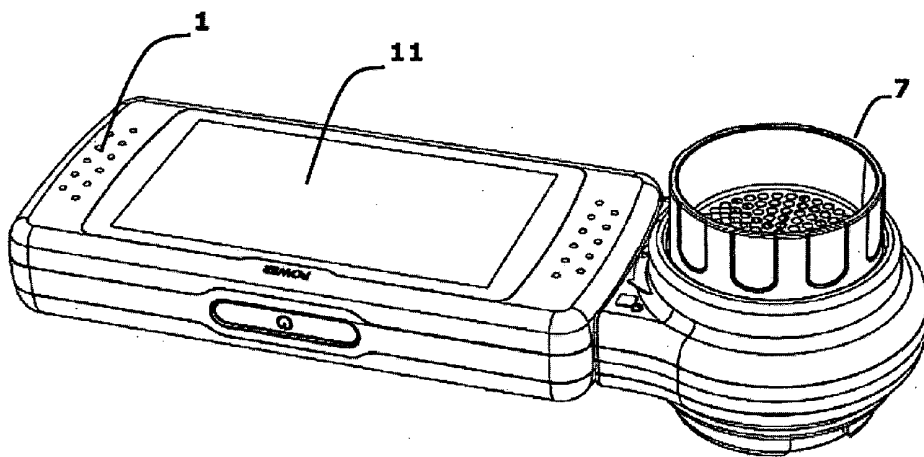

FIG. 3

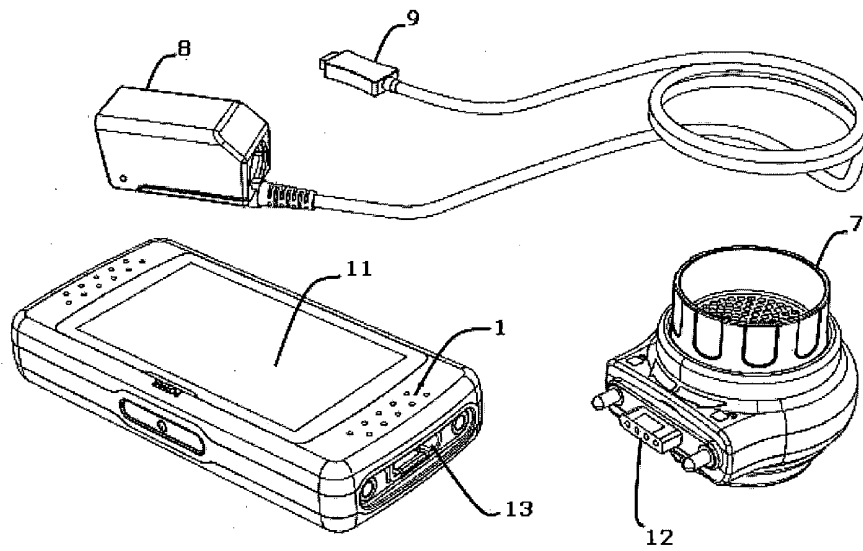

FIG. 4

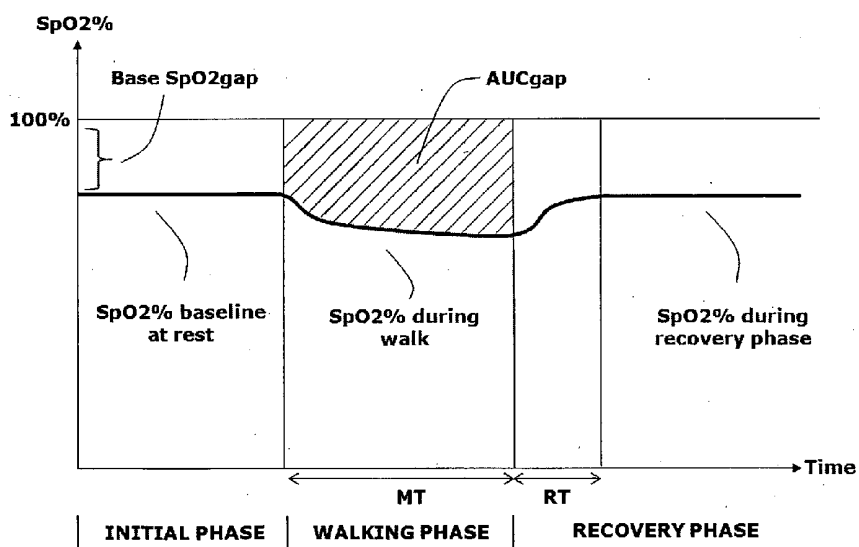

FIG. 5

**PORTABLE DEVICE FOR MONITORING
AND REPORTING OF MEDICAL
INFORMATION FOR THE EVIDENCE
-BASED MANAGEMENT OF PATIENTS WITH
CHRONIC RESPIRATORY DISEASE**

[0001] The present invention relates to an integrated tele-health system/device for the monitoring and reporting of medical information for the evidence-based management of patients with chronic respiratory disease.

[0002] The device comprises substantially a central unit which measures and collects information related to the state of health of the patient, and it is provided with means for wireless or cable transmission of the collected data using a microprocessor based system with a touch screen display, USB communication port and Bluetooth. According to the invention, the device further comprises: a removable sensor for the measurement of respiratory air flow and volume, a removable pulse oximetry sensor and a motion sensor. Stored data can be then delivered through landline, broadband, wireless and cell-phone technology to be received by a web server and can then be accessed by medical staff.

[0003] Being completely portable, the device according to the invention is provided with a battery of known type, which can be substituted by the user or it can be rechargeable.

INTRODUCTION

[0004] At the base of the new requirements for better and more intelligent treatments must be a series of evidence-based management tools to help to create a more rational and intelligent way to deal with health based on evidence.

[0005] Scientific, economic, cultural and social progress have combined to help us obtain significant advantages in health management. The average life expectancy of the population has increased over the last ten years. The conditions which society must come to terms with are those chronic degenerative diseases, which although they cannot be cured, can be kept under control with suitable pharmaceutical and behavioural therapies.

[0006] The respiratory pathologies are at the current state of play one of the most significant health problems for the number of patients afflicted - even younger people - as well as for the high rate of mortality and the prevalence, and the significantly debilitating effects on the patients and for the very high direct and indirect costs associated.

[0007] According to the American Thoracic Society (ATS) and the European Respiratory Society (ERS) "chronic obstructive pulmonary disease (COPD) affects about 210 million people globally and causes some 3 million deaths annually. The disease is a major drain on healthcare budgets with 50% of costs accounted for by hospital admissions, much of which could be avoided through development of more responsive models of care that allow earlier recognition and treatment of exacerbations".

[0008] An exacerbation can be defined as a sustained worsening of the patient's symptoms from that beyond normal day-to-day variation. Exacerbations can result in a more rapid decline of lung function, increased peripheral muscle weakness, decreased quality of life, increased health care costs, and increased mortality. It has been demonstrated that early therapy speeds exacerbation recovery, and reduces health care utilization. Patients should be instructed to respond early in the course of an exacerbation by activating their predetermined action plan.

[0009] In a self-management program, well-designed clinical trials that provide valid, reproducible and interpretable results should also instruct the patient to treat and prevent the onset of respiratory exacerbations.

[0010] Real-time patient remote monitoring and screening for homecare purposes can be delivered through landline, broadband, wireless and cell-phone technology. These tele-health applications may forever change, while dramatically improving the way healthcare will reach the ever increasing number of COPD patients worldwide.

[0011] Chronic respiratory diseases can lead to chronic respiratory failure: inadequate gas exchange by the respiratory system, with the result that arterial oxygen and/or carbon dioxide levels cannot be maintained within their normal ranges. When chronic respiratory failure occurs, there is an increase in the impact of the disease on the patient's daily life and well-being.

[0012] Lifestyle, which includes physical inactivity in daily life, plays a very important role in terms, of both disability and mortality. It is now well recognized that regular physical activity may prevent or delay the onset or progress of different chronic diseases. It is known, for instance, that in patients with chronic obstructive pulmonary disease (COPD), lower levels of physical activity in daily life are related to higher risk of hospital readmission and also to shorter survival.

[0013] One of the main consequences of chronic respiratory disease is a daily activity performance drop, which must be measured in this patient population. Therefore, the assessment of the amount and intensity of physical activity in daily life is of major importance given the close relationship between activity levels and health.

[0014] A better understanding of the present invention will be obtained with reference to the following description and with reference to the attached plates of drawings, which illustrate merely by way of non-limiting example a preferred embodiment thereof:

[0015] FIG. 1 is a block diagram of the device according to the present invention;

[0016] FIG. 2 shows a preferred embodiment of the device with flow and volume sensor connected;

[0017] FIG. 3 is a different view corresponding to FIG. 2;

[0018] FIG. 4 shows the invention with sensors disconnected; and

[0019] FIG. 5 is a diagram of SpO₂% vs time during 6MWT.

DESCRIPTION OF THE INVENTION

[0020] In view of the above, it appears clear that the state of health of a patient affected by respiratory disease like COPD requires a daily "overview" of several vital signs (or vital parameters) in order to spot in advance any potential worsening of the condition which, if not brought under control, generally leads to exacerbations and eventually to a spell in hospital.

[0021] The present invention is specifically aimed to provide a device and/or system for carry out said "overview" directly by the patient him/herself.

[0022] Often these patients are able to monitor several vital signs at home, for instance pulse oximetry, which with respect to the patients baseline resting value can be subject to a fall off under exercise or during sleep, when the spontaneous ventilation reduces for physiological reasons.

[0023] Pulse oximetry is the most simple, non-invasive method for evaluating the level of oxygen in the blood. This

measurement provides a parameter called oxygen saturation (% SpO₂), closely related to SaO₂ measured by blood sampling, a much more complicated and invasive method. There isn't life without oxygen: this is why pulse oximetry is considered a vital sign.

[0024] In the past few years through technological progress, which has enabled the production of pocket-size pulse oximeters and spirometers at reduced costs, many doctors have included the measurement of % SpO₂ and expiratory peak flow (PEF) as vital signs equally as important as the standard ones (such as body temperature, heart rate, blood pressure), used when performing a general medical check-up of a patient to identify the type of disorder present.

[0025] Performance Evaluation

[0026] A fundamental objective in the management of respiratory disease is to increase a patient's performance in routine daily activities. Performance assessment is possible by either patient reporting or by direct observation by noting the rate, speed or efficiency of a particular activity. However this impractical process is difficult to standardize and extremely time consuming.

[0027] According to the present invention, it is provided a device comprising motion detectors and activity monitors that allow for a plausible daily activity evaluation in any setting.

[0028] The precise quantification of physical activity is of particular importance in measuring the outcomes of interventions in frail, sedentary populations such as COPD and the elderly, because even small improvements in physical functioning such as walking and balance may translate into significantly improved quality of life.

[0029] Objective assessment of daily activity performance in non laboratory-settings is becoming a reality thanks to activity monitors in the form of a simple pedometer which counts the number of steps taken by a patient to more elaborate devices capable of measuring movement on three axis.

[0030] An accelerometer is a technologically very advanced device, which allow the quantity and intensity of movements to be determined and measured. The instrument is able to measure both the total amount and the intensity of spontaneous activities performed throughout the day in the subject's own environment.

[0031] Walking is now considered as the most important and common type of physical activity performed in daily life and is the activity targeted for improvement in most pulmonary rehabilitation programs. Walking more in daily life is an important indicator of improvement after respiratory rehabilitation protocols, and this walking can indeed be accurately assessed by motion sensors. Some tests can be self-paced such as the 6-minute walk test (6MWT), and require no advanced training or special equipment. The 6MWT is a very simple, safe and reproducible fitness test, and it is widely used in the evaluation of respiratory diseases. The test requires no complex instrumentation, can be made easily even by patients with a severe level of disability and, last but not least, represents more closely than any other test "normal life activity" and so is therefore an excellent indicator of the quality of life of the patient.

[0032] Guidelines for the application of the 6MWT in a clinical setting were developed by the American Thoracic Society (ATS) in 2002. The standard procedure requires that at the start of the test and then at every one minute interval during the test, a pulse oximeter is used to record (a) the

saturation (SpO₂%) and (b) the heart rate (BPM) of the patient. In addition, at the end of the test, the total distance covered should be recorded.

[0033] People who suffer of moderately severe respiratory impairment can perform a 6MWT which has proven to be extremely useful to measure patient response to therapeutic interventions for, pulmonary and cardiac disease.

[0034] It is common practice that, in the event that the SpO₂ level falls below 82% during the 6MWT, the test should be halted and then repeated with the patient given supplemental oxygen (O₂).

[0035] In this case, the test is generally repeated following a rest interval of at least 15 minutes, with increasing oxygen flow of 2, 4 and then 6 litres per minute until the patient is able to complete the test maintaining an SpO₂% level of at least 90% during the whole test.

[0036] According to the present invention, the mechanisms of exercise intolerance can now be studied in further depth through the acquisition of physiologic measurements such as the distance walked and the reduction of the oxygen level in the blood during the exercise.

[0037] Walking is a simple yet ideal form of daily exercise to evaluate the overall response of the pulmonary and cardiovascular systems, systemic circulation, peripheral circulation, blood, neuromuscular units, and muscle metabolism.

[0038] Exercise testing in the routine clinical assessment of the functional status of a patient is now considered a fundamental component because health-related quality of life, survival rates and hospitalization rates are all affected by the degree of exercise tolerance impairment in COPD patients.

[0039] Calculation of the CS Index or O₂_GAP for Long Term Oxygen Prescription

[0040] One of the objective of the invention is the use of the 6MWT to determine the prescription of long term oxygen. An equation which can be integrated into an electronic device, in order to calculate the oxygen requirement of the patient through a 6MWT carried out without any additional oxygen supply to the patient.

[0041] The equation was derived according to the following method. Ninety six patients with respiratory disease were required to carry out the 6MWT in ambient air and without any supplementary oxygen. The parameters of this 6MWT were recorded every minute ie the distance walked, the SpO₂% from the start to the end of the test, as well as the Heart Rate, the recovery time, the degree of breathlessness and fatigue, as per the international guidelines.

[0042] Then using this data, the following parameters were derived or calculated as illustrated below.

[0043] (a) AUC_{gap}, which represents the difference between the area under the curve where SpO₂%=100% vs. time and the area below the curve showing the SpO₂% vs. time of the patient during the test. The time limits for the evaluation of the area are represented by the duration of walk phase (see FIG. 4).

[0044] (b) MT, which represents the test duration expressed in minutes (from a minimum of 0 to a maximum of 6).

[0045] (c) Base SpO₂gap, which represents the difference between SpO₂%=100% and the SpO₂% baseline at rest before the start of the walk phase.

[0046] (d) RT which represents the recovery time in seconds of the patient at the end of the test, for the SpO₂ value to return to the base value recorded before the test, even if the test is stopped before the full 6 minutes.

[0047] (e) PPD which represents the percent predicted distance, which is the percentage of the distance covered by the patient during the test compared to the distance covered by a normal subject. The distance (in metres) covered by a normal subject is calculated from the equation by Enright and Sherill, where:

[0048] For males: $(7.57 \times \text{height in cm}) - (5.02 \times \text{age in years}) - (1.76 \times \text{weight in kg}) - 309$

[0049] For females: $(2.11 \times \text{height in cm}) - (5.78 \times \text{age in years}) - (2.29 \times \text{weight in kg}) - 667$

[0050] In the case that a patient has a base SpO₂% at rest below 82% prior to the start of the test, then the patient cannot make the test without a supplement of 6 L/min of oxygen.

[0051] The equation for the calculation of the CS Index or O₂_Gap, is expressed as follows:

$$\left\{ \begin{array}{l} \text{If } MT \geq 1, \text{ then:} \\ O_2(L/min) = \frac{\left\{ \frac{[(AUC_{gap} / MT) +]^2 + \sqrt{RT}}{(BaseSPO_2gap / 7)} \right\} - 9.31}{8.94} \\ \text{If } MT = 0, \text{ then:} \\ O_2(L/min) = 6 \end{array} \right.$$

[0052] This equation enables us to calculate the O₂_Gap, that we have defined also CS Index, which represents the quantity of oxygen expressed in L/min which must be given to a patient in order that the patient can complete the 6MWT without desaturating below the level of 90% SpO₂, and also without desaturating below the level of 82% SpO₂ for the patients who require 6 L/min of oxygen in order to complete the test.

[0053] The application of the CS Index equation in the calculation of the "oxygen gap" in the 6MWT carried out without the supply of supplemental oxygen, to calculate the oxygen requirement when the test is carried out with supplemental O₂.

[0054] The capacity of the 6MWT to determine the quantity of oxygen required for the test to be carried out has been evaluated using a group of patients which included:

[0055] (a) A sub group of patients able to make the test without supplemental O₂ (0 L, n=27),

[0056] (b) A sub group requiring supplemental oxygen at a flow rate of 2 L/min (2 L, n=24)

[0057] (c) A sub group requiring supplemental oxygen at a flow rate of 4 L/min (4 L, n=24)

[0058] (d) A sub group requiring supplemental oxygen at a flow rate of 6 L/min (6 L, n=21).

[0059] The application of the equation to calculate the CS Index to the analysis of the results of the 6MWT in patients within the same subgroup enables distinctions to be made between these patients.

[0060] The advantages of using the CS Index equation in clinical practice and in pulmonary/respiratory laboratories. The equation is of considerable benefit in the management of respiratory patients within pulmonary and respiratory laboratories, in the pulmonology, cardiology and rehabilitation fields as the equation, as illustrated above, enables the GAP_O₂ (ie the O₂ requirement to complete the test) to be determined by a single standard walking test without any supplemental oxygen. In this way, the successive tests with supplemental oxygen supplies of 2 L/min up to 6 L/min are no

longer required, it is sufficient to analyse the parameters measured in the 6MWT using the new equation.

[0061] This brings both a greatly reduced level of effort and stress for the patient as well as a saving for the respiratory lab in terms of physical resources as well as trained personnel due to the reduced time required, the new total time could be even 1/8-1/10 of the time required to determine the amount of oxygen necessary.

[0062] In particular, the function obtained predicts the oxygen requirement as shown in the successive 6MWT carried out with an O₂ flow from 0 to 6 L/min, showing in a statistically significant way the quantity of oxygen required to make the test without desaturating below 90% SpO₂ or below 82% for the patients needing 6 L/min O₂.

[0063] In conclusion, the equation calculates the size of the oxygen gap in the walking test with a high degree of sensibility, specificity and diagnostic accuracy. with sensibility=91.35%, specificity=92.59% and diagnostic accuracy=91.88%, in the calculation and prediction of the O₂ requirement to complete the exercise.

[0064] Quality-of-Life Measurements

[0065] Quality of life can be defined as "the gap between that which is desired in life and that which is achieved". The areas affected by health status which reflect the effect of respiratory disease on the ability to perform and enjoy daily activities are the main focus of health-related quality of life (HRQL)

[0066] Increasing documentation of the favourable effect of rehabilitation therapy for COPD patients is proof that no other therapy has the same rate of improvement in exercise endurance, dyspnea, functional capacity and overall quality of life.

[0067] According to the most recent guidelines published by the main international scientific lung societies, the assessment of patient-centered outcomes, such as symptoms, performance in daily activities, exercise capacity and health-related quality of life (HRQL), should be an integral component of pulmonary disease management. As well as the value of oxygen saturation, the management suggested by the new guide lines requires the evaluation of the improvement of the performance and of the exercise capacity, intended to mean the patient's ability to engage in activities of daily living, the measurement of the respiratory function by spirometry as well as the compilation of a specific questionnaire on the quality of life and on the symptoms.

[0068] In practice for the patient, and in particular for the older patients, it is very complex if not impossible to manage several different medical devices able to measure all of the parameters proposed by the new guide lines. In addition, it is very difficult for the patient to transfer all of the measured parameters to the medical centre.

[0069] The innovative new device/system according to the present invention, is developed to measure and to transmit all of the required diagnostic parameters for the "home care" monitoring of a patient with chronic respiratory disease. However, it has become clear that regardless of the type of respiratory disease, patients experience a substantial morbidity from secondary impairments, such as peripheral muscle, cardiac, nutritional, and psychosocial dysfunction.

[0070] This device carries out the functions required by the healthcare givers, who need to provide a better level of care based on new high technology at low cost with complete integration. The clinical application consists of non invasive and high technology testing, with low cost and easy to use

instruments and sensors. The device is simple to use which is a new development for home care, where the technology has not always been simple, especially for older patients.

[0071] So the traditional concept of a visit to the doctor is extended to a virtual visit, as every patient can make use of these services even staying at home. And thus a new intelligent and completely digital ambient is created, combining diagnostic instrumentation with information technology as well as communications.

[0072] A Comparison of the Physical Activity Carried Out by a Patient

[0073] According to the latest, scientific publications in the field of pneumology, the distance walked is of fundamental importance in the evaluation of the state of health of a patient with chronic respiratory disease. In addition, when two tests by the same patient are compared, then if the trend of the desaturation (in other words the reduction of the % SpO₂) during the test is different, then the evaluation only of the distance walked is not sufficient.

[0074] Let us therefore define an innovative index/parameter: Desaturation Area/Movement.

[0075] This parameter represents the area under the curve, including the baseline value at rest of the % SpO₂ value and the graph of the % SpO₂ during exercise, for instance during walking, shown in relation to the total movement recorded in all three directions by the accelerometer activity during the test. This area under the curve can also be shown in relation to the movement represented by the number of steps taken, also calculated by the accelerometer.

[0076] Considering that the device according to the present invention is able to measure simultaneously the % SpO₂ (pulse oximetry) as well as the physical activity (accelerometry), the device is also able to calculate said index (Desaturation Area/Movement) and to show it on the display at the end of a measurement session.

[0077] This represents a peculiar feature of the invention and has a very significant implication in the evidence-based evaluation of the cardio-respiratory system during physical exercise, and thus in the evidence-informed manner. Indeed until now, as well as the difficulty of having to use two different devices, for instance a pedometer and a pulse oximeter, to measure the SpO₂ values and the distance walked, this index was simply not available.

[0078] The current situation gives great difficulties both to the patient seeking efficient self-management, as well as to the medical staff. Using the present invention these problems can be completely overcome.

[0079] In other words, if we consider a car which is in perfect mechanical condition, it is logical to think that this car is able to cover a greater distance with a litre of fuel compared to a car which is not in perfect mechanical condition. In the same way, a patient during physical activity will have a lesser or a greater level of fall of the % SpO₂ (desaturation) according to his or her state of health. The relationship between Desaturation Area and Movement indicates the level of desaturation in relation to the movement or the distance covered and can therefore be considered an index of the performance of the patient.

[0080] The Desaturation Area/Movement enables the comparison of two measurement sessions in order to measure the variation in the state of health of the patient through their own performance and exercise capacity.

[0081] Description of the Sensors

[0082] The heart of the system is the central unit which is based on microprocessor technology. The invention is also provided with input/output means by which the user interfaces with the unit. These I/O means are preferably constituted by a touch-screen display.

[0083] In a preferred embodiment, when the device is switched on, it requires the insertion of some general and some respiratory specific health-related quality of-life questions. This questionnaire is first configured for the patient by the health team, who can switch on or off the various optional questions according to the specific patients requirements. Individual components of quality of life, for instance working or resting activity etc., include symptoms, functional status, mood. Questionnaires can measure these components individually or with a composite score. When the information session is completed then the patient can select the type of diagnostic test to be carried out.

[0084] One of the main advantages offered by this invention is that the central unit comprises an electrical and mechanical connection assembling system for connecting to a removable sensor for the measurement of respiratory air flow and volume. In order to allow a simpler access to the other functions the system offers, this sensor can be completely removed from the central unit when spirometry testing is not required. When the flow measurement head has been connected to the central unit through the associated conjugated connector with conjugate contact elements, spirometry tests can be carried out to determine the most important spirometry parameters such as the PEF, FEV1, FEF25%-75%. At the end of the test, the unit displays the results and compares them to the reference values which have been set by the doctor during the device setup. Thus the patient can view various messages about his/her state of health. When the test is finished the respiratory measurement head (the complete sensor) can be removed from the central unit.

[0085] The central unit can be placed within a belt worn close to the body on the waist, wrist or ankle of the patient, and then a finger probe is worn connected to the central unit for the pulse oximetry, to measure both the % SpO₂ and the Pulse Rate (BPM). The test can be carried out at rest, or during physical exercise or even overnight during sleep.

[0086] According to a peculiar feature of the invention, at the same time as the pulse oximetry is measured and recorded, the triaxial accelerometer which is integrated into the central unit, carries out the function of activity monitor as well as motion detector.

[0087] If the patient walks then the number of paces can be detected and recorded as well as the physical activity in each of the three directions. If instead the patient sleeps then the position of the body can be recorded during sleep face up, facedown, right side or left side, etc., as well as the movements during the complete test period.

[0088] At the end of the test, any periods of arterial desaturation, will be analyzed and compared to the results of the physical activity measured by the accelerometer. Indeed, it is well known that in many cases patients with chronic respiratory conditions will have a rapid fall off in arterial oxygen saturation following exercise, even very modest exercise.

[0089] Specifically the calculation of the index Desaturation Area/Movement or the steps taken, will give very important information for each test, or on the improvement or deterioration in the respiratory condition by comparing the current test with a previous test made: this also enables effective

tive self management by the patient who has objective data with which to compare his or her exercise tolerance and to remain within the limits suggested by the doctor.

[0090] A further and very significant advantage of the invention is the possibility to transmit the test data to a web server so that the test data can then be seen by the doctor and thus the doctor can vary the therapy as required very quickly indeed. In some cases, these patients are treated with oxygen at home in order to compensate any desaturation.

[0091] In addition, desaturation during sleep, and above all the rapid desaturation caused by sleep apnea, can be linked to a body position and the analysis of the sleeping position is possible thanks to the accelerometer within the device. Also, even minimum periods during sleeping hours when the patient stands up or walks can be identified as waking hours and thus excluded from the sleep analysis.

[0092] Further Advantages of the Invention

[0093] The subject of this invention is a new device with a specific and innovative way of use both for the patient who uses it and also for the manufacturer.

[0094] The patient has the advantage of being able to use and to purchase, if required, a single product - i.e. the central unit - which carries out four functions: questionnaire, spirometer, pulse oximeter and activity monitor or motion detector. Furthermore, as an alternative, he/she can also reduce the number of sensors depending on his/her specific diagnostic or therapeutic requirements. Then later on if the requirements change, additional sensors can be purchased without the need of substitute the central unit.

[0095] Having a single central unit Which is able to manage and to integrate with every sensor within the system guarantees a major simplicity of use as well as an economic advantage, and the device fully respects the recommendations of the international guide lines for the management of chronic respiratory disease.

[0096] The manufacturer has the advantage of manufacturing a single product which can include one or more sensors, according to the needs of the customer. This will reduce the production costs and also optimize the level of stock required to be held, given that only one instead of three different devices needs to be manufactured.

[0097] In more detail, the respiratory measurement head through the associated conjugate connector with conjugate contact elements, which then connects to the central unit, represents a very innovative technology and simplifies the use for the patient.

[0098] For instance, during the walking test to measure the pulse oximetry and the movement, it is very convenient to reduce the size of the device to be carried by removing the respiratory measurement head and thus facilitate walking. The same advantage is also available when measuring overnight pulse oximetry, when the patient is connected to the device worn on the belt.

[0099] All of these aspects improve the use of the device and enable multiple devices to be incorporated into a single system able to carry out a multitude of fundamental diagnostic tests, vital for the home management of chronic respiratory disease.

[0100] So to summarize, the integration into a single device of three different sensors for spirometry, pulse oximetry and for motion analysis and of the derived index which compares the desaturation with the movement, completely and totally follows the recommendations of the latest guide lines of the

major Scientific Societies for the home management of patients with chronic respiratory disease.

[0101] So the very significant strength of this new invention is the real application of these guide lines using a single and simple to use device.

LIST OF REFERENCE USED IN DRAWINGS:

- [0102]** (1) central unit
- [0103]** (2) Bluetooth module
- [0104]** (3) USB port for data transmission
- [0105]** (4) external power supply
- [0106]** (5) speaker for audio feedback
- [0107]** (6) test report output
- [0108]** (7) flow and volume sensor
- [0109]** (8) pulse oximetry finger sensor
- [0110]** (9) oximetry sensor male connector
- [0111]** (10) oximetry sensor female connector
- [0112]** (11) touch screen display
- [0113]** (12) flow and volume sensor female conjugated connector
- [0114]** (13) central unit male, conjugated connector.

1-16. (canceled)

17. Device for monitoring and reporting of medical information for the evidence-based management of patients with chronic respiratory disease, said device being portable and substantially comprising a central unit (1) which measures and collects information related to the state of health of the patient, a removable sensor for the measurement of respiratory air flow and volume with special connecting means, a removable pulse oximetry sensor and motion sensor/detector means, characterized in that it is provided with means for measuring simultaneously a parameter called oxygen saturation or % SpO₂ (pulse oximetry) as well as a physical activity of the patient (accelerometry), wherein the central unit (1) is able to calculate a CS index or O₂_Gap representing the quantity of oxygen expressed in L/min which must be given to the patient in order that the patient can complete a 6-minute walking test or 6MWT without desaturating below the level of 90% SpO₂, and also without desaturating below the level of 82% SpO₂ for the patients who require 6 L/min of oxygen in order to complete the test, said central unit (1) showing said CS index on a display at the end of a measurement session.

18. Device according to claim 17, characterized in that said CS index or O₂_gap is calculated by using the following equation:

$$\begin{cases}
 \text{If } MT \geq 1, \text{ then:} \\
 \quad O_2(L/min) = \frac{\left[\frac{(AUC_{gap} / MT) + \sqrt{RT}}{(BaseSPO_{2gap} / 7)} \right]^2 + \sqrt{RT}}{8.94} - 9.31 \\
 \text{If } MT = 0, \text{ then:} \\
 \quad O_2(L/min) = 6
 \end{cases}$$

where:

AUC_{gap} represents the difference between the area under a curve where SpO₂%=100% vs. time and the area below a curve showing the SpO₂% vs. time of the patient during the test;

MT represents the test duration expressed in minutes (from a minimum of 0 to a maximum of 6);

Base SpO₂gap represents the difference between SpO₂%=100% and the SpP₂% baseline at rest before the start of the walk phase of the 6MWT;

RT represents the recovery time in seconds of the patient at the end of said test, for the SpO₂ value to return to the base value recorded before the test, even if the test is stopped before the full 6 minutes;

PPD represents the percent predicted distance, which is the percentage of the distance covered by the patient during said test compared to the distance covered by a normal subject.

19. Device according to claim 17, characterized in that it is provided with means for wireless or cable transmission of the collected/stored information using a microprocessor based system comprised in said central unit (1); said information related to the patient being delivered through landline, broadband, wireless and cell-phone technology to be received by web server and can then be accessed by medical staff.

20. Device according to claim 17, characterized in that it is provided with an input/output touch screen display, USB communication port and/or Bluetooth and/or wireless communication means.

21. Device according to claim 17, characterized in that said motion sensor/detector means comprise motion detectors and activity monitors for evaluation of a plausible daily activity of the patient in any setting.

22. Device according to claim 21, characterized in that said motion sensor/detector means comprise a triaxial accelerometer for "activity monitor", that is suitable to discriminate between low, moderate and high overall activity levels as well as to categorise individuals as sedentary, moderately active or active and it is also able to detect a variety of body positions and physical activities; the output of the accelerometer being measured in the three dimensions —X=anteroposterior, Y=vertical, Z=mediolateral vectors—and being then integrated by the central unit (1) to represent movement as velocity over time using the square root of the sum of squares of each individual vector.

23. Device according to claim 17, characterized in that the collecting/storing information relating to the patient comprise the acquisition of physiologic measurements such as the distance walked and the reduction of the oxygen level in the blood during the exercise.

24. Device according to claim 22, characterized in that it is provided with means for measuring simultaneously the % SpO₂ (pulse oximetry) as well as the physical activity (accelerometry), wherein the central unit (1) is able to calculate a Desaturation Area/Movement index and to store and show it on a display at the end of a measurement session; said index representing the area under the % SpO₂ curve, including the baseline value at rest of the % SpO₂ value and the graph of the % SpO₂ during exercise, for instance during the 6-minute walking test, obtained in relation to a total movement recorded in all three directions by the accelerometer activity during the test.

25. Device according to claim 17, characterized in that the central unit (1) comprises an electrical and mechanical connection assembling system (12, 13) connecting to a removable spirometry sensor (7) for the measurement of respiratory air flow and volume thereby obtaining that when spirometry testing is not required the device is absolutely and completely operational for providing its other functions to the user.

26. Device according to claim 25, characterized in that when the spirometry sensor has been connected, to the central

unit (1) through the electrical and mechanical connection assembling system, comprising an associated conjugated connector (12) with conjugate contact elements (13), spirometry tests can be carried out to determine the most important spirometry parameters like the PEF, FEV₁, FEF_{25%-75%}, thereby obtaining that at the end of the test, the central unit (1) displays the results and compares them to the reference values which have been set by the doctor during the device setup, further providing to the patient suitable various messages about his/her state of health, when the test is finished the spirometry sensor head being removed from the central unit (1).

27. Device according to claim 17, characterized in that the central unit (1) can be placed within a belt worn close to the body on the waist, wrist or ankle of the patient, and then a finger probe which is removably connected to the central unit (1) is worn for the pulse oximetry test, for measuring both the % SpO₂ and a Pulse Rate (PPM), thereby obtaining that the test can be carried out at rest, or during physical exercise or even overnight during sleep; wherein at the same time as the pulse oximetry is measured and recorded, a triaxial accelerometer which is integrated into the central unit (1), carries out the function of activity monitor as well as motion detector.

28. Device according to claim 22, characterized in that said central unit (1) comprises data processing and storing means and the triaxial accelerometer, so that when the patient walks then the number of paces can be detected and recorded as well as the physical activity in each of the three directions, while when the patient sleeps then the position of the body can be recorded during sleep: face up, face down, right side or left side etc., as well as the movements during the complete test per

29. Device according to claim 28, characterized in that said data processing means are suitable for linking a level of fall of the % SpO₂ or desaturation during sleep, and above all any rapid desaturation caused by sleep apnea, to a body position, even minimum periods during sleeping hours when the patient stands up or walks being furthermore identified as waking hours and thus excluded from the sleep analysis.

30. Device according to claim 17, characterized in that it comprises means for transmission of the collected data of a patient to a web server so that said data can then be seen by a doctor and thus the doctor can vary the therapy as required very quickly indeed; in some cases, these patients being treated with oxygen at home in order to compensate any desaturation.

31. Method of using the device according to claim 17 for the analysis of a six minute walk test (6MWT), said device being provided with means for calculating a CS index representing the quantity of oxygen expressed in L/min which must be given to the patient in order that the patient can complete the 6-minute walking test or 6MWT without desaturating below the level of 90% SpO₂, and also without desaturating below the level of 82% SpO₂ for the patients who require 6 L/min of oxygen in order to complete the test, the method being carried out in the following clinical applications

the Calculation of the requirement of oxygen during exercise using the 6MWT for the prescription of long term oxygen therapy (LTOT); and/or

the Calculation of the oxygen requirement using the 6MWT in the field of rehabilitation therapy; and/or

the Calculation of the severity of a lung disease such as COPD, pulmonary fibrosis and other respiratory condi-

专利名称(译)	便携式设备，用于监测和报告基于证据的慢性呼吸道疾病患者管理的医疗信息		
公开(公告)号	US20130184540A1	公开(公告)日	2013-07-18
申请号	US13/814824	申请日	2010-08-09
[标]申请(专利权)人(译)	博斯凯蒂萨科PAOLO SALTINI CESARE calzetta LUIGINO		
申请(专利权)人(译)	博斯凯蒂萨科PAOLO SALTINI, CESARE CALZETTA, LUIGINO		
当前申请(专利权)人(译)	MIR SRL医学国际研究		
[标]发明人	BOSCHETTI SACCO PAOLO SALTINI CESARE CALZETTA LUIGINO		
发明人	BOSCHETTI SACCO, PAOLO SALTINI, CESARE CALZETTA, LUIGINO		
IPC分类号	A61B5/00 A61B5/11 A61B5/087 A61B5/1455		
CPC分类号	A61B5/087 A61B5/14551 A61B5/4884 G06F19/3418 A61B5/1118 A61B2560/0431 G06F19/00 G16H40/63		
其他公开文献	US10201308		
外部链接	Espacenet USPTO		

摘要(译)

一种综合远程保健系统/设备，用于监测和报告医疗信息，用于慢性呼吸道疾病患者的循证管理。该设备包括中央单元，其测量和收集与患者的健康状态有关的信息，并且具有用于使用具有触摸屏显示器的USB微处理器系统，USB通信端口和用于无线或有线传输所收集的数据的元件。蓝牙。该装置还包括：用于测量呼吸空气流量和体积的可拆卸传感器，可拆卸脉搏血氧饱和度传感器和运动传感器。然后，存储的数据可以通过固定电话，宽带，无线和蜂窝电话技术传送，由网络服务器接收，然后由医务人员访问。由于完全便携，该装置设有已知类型的电池，该电池可由用户代替或可以是可充电的。

