



US 20100331639A1

(19) **United States**

(12) **Patent Application Publication**  
**O'Reilly**

(10) **Pub. No.: US 2010/0331639 A1**

(43) **Pub. Date: Dec. 30, 2010**

(54) **PULSE OXIMETRY SYSTEM FOR ADJUSTING MEDICAL VENTILATION**

**Publication Classification**

(76) Inventor: **Michael O'Reilly**, Dana Point, CA (US)

(51) **Int. Cl.**  
**A61B 5/00** (2006.01)

Correspondence Address:  
**KNOBBE MARTENS OLSON & BEAR LLP**  
**2040 MAIN STREET, FOURTEENTH FLOOR**  
**IRVINE, CA 92614 (US)**

(52) **U.S. Cl.** ..... **600/323**

(21) Appl. No.: **12/824,087**

(57) **ABSTRACT**

(22) Filed: **Jun. 25, 2010**

**Related U.S. Application Data**

(60) Provisional application No. 61/222,087, filed on Jun. 30, 2009.

A physiological monitoring system can include a physiological monitor having one or more processors that can derive oxygen saturation values from a patient. The oxygen saturation values can correspond to values of oxygen saturation in blood at a tissue site of the patient. The physiological monitor can output an indication of amplitude of the differences per respiratory cycle in the oxygen saturation values.

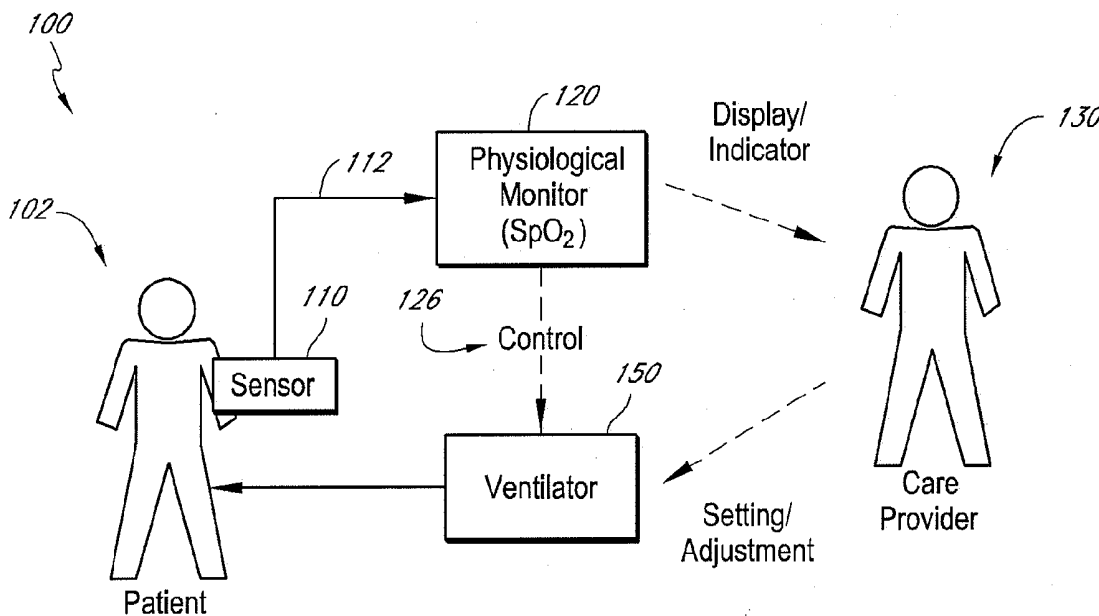

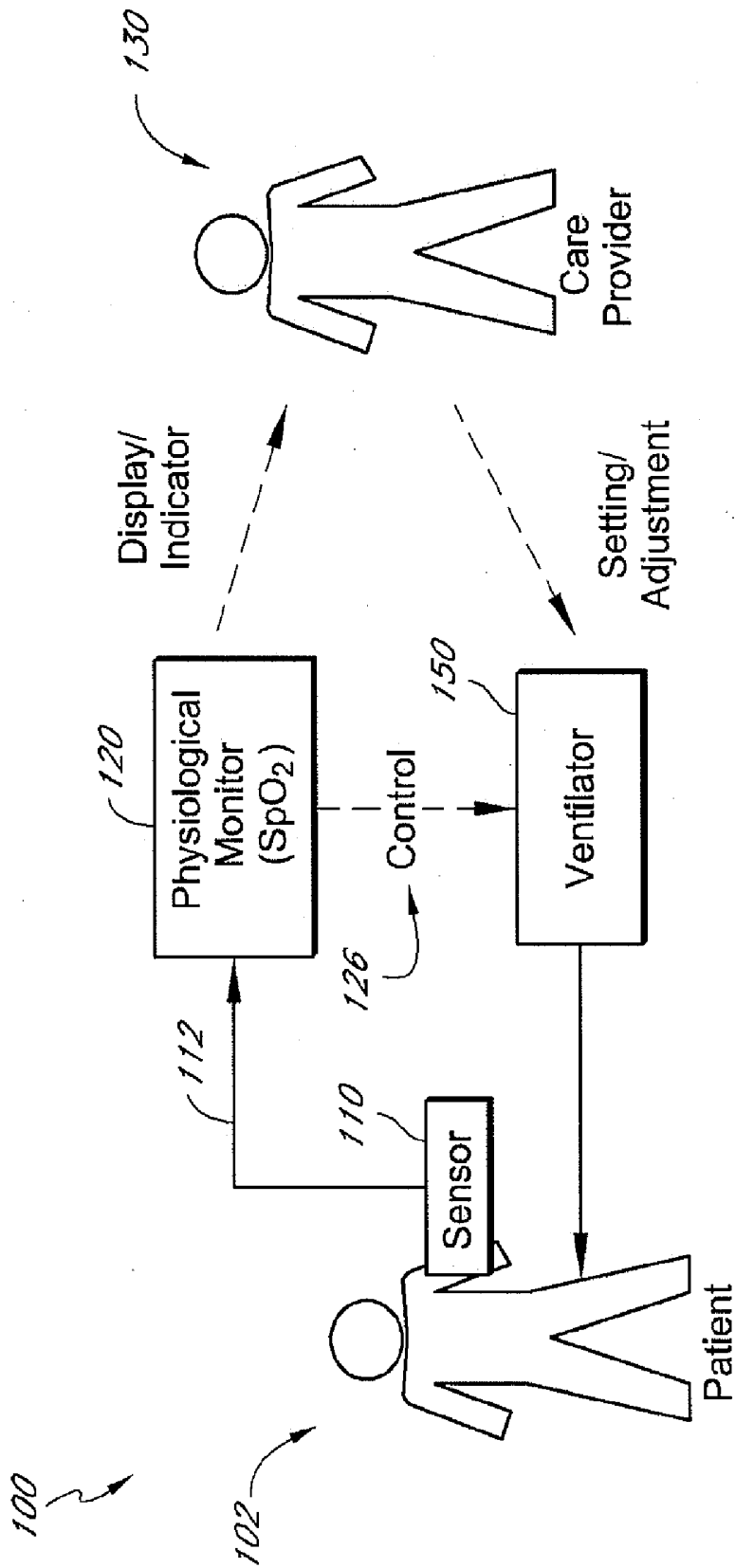

FIG. 1

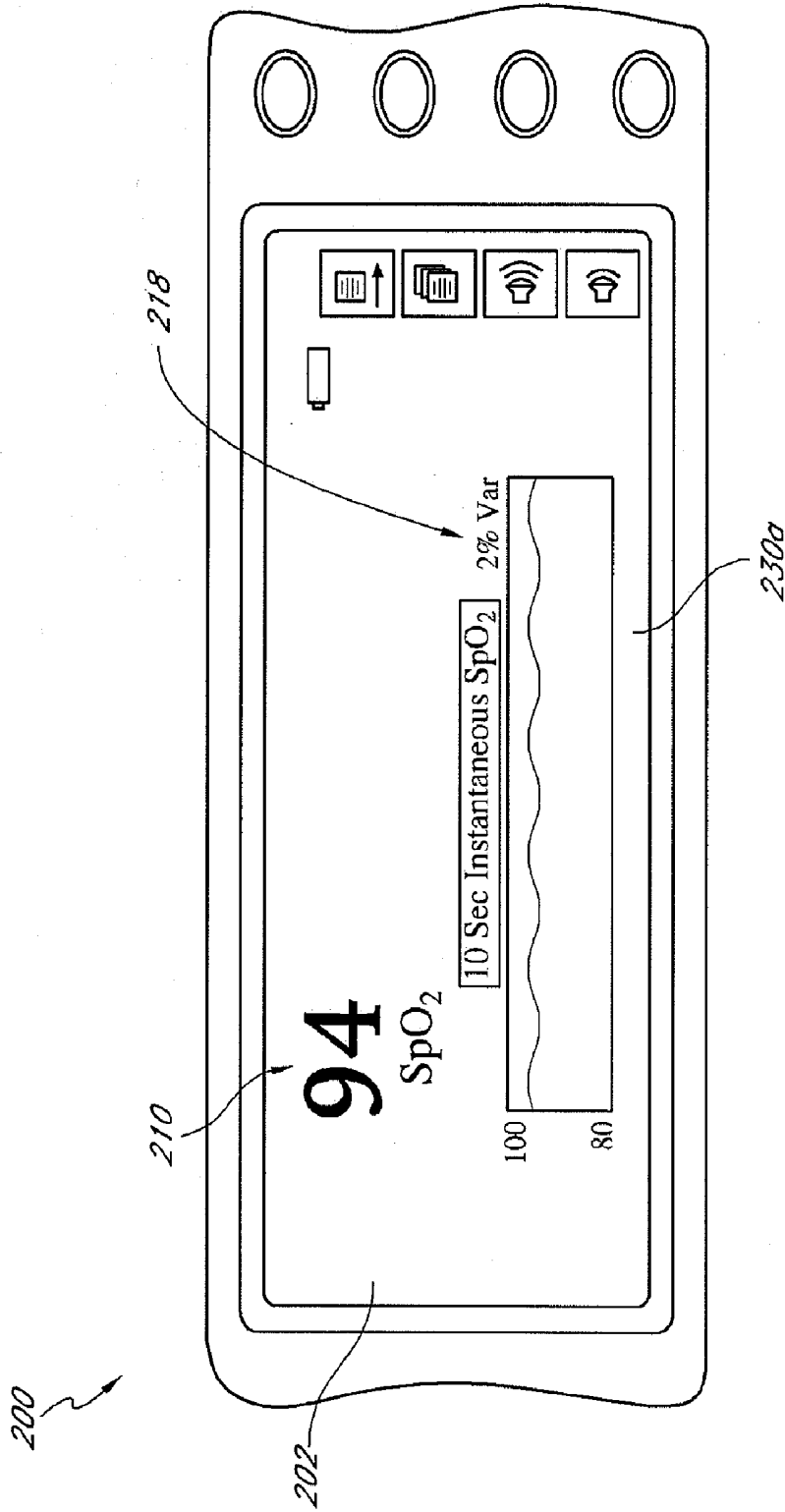

FIG. 2

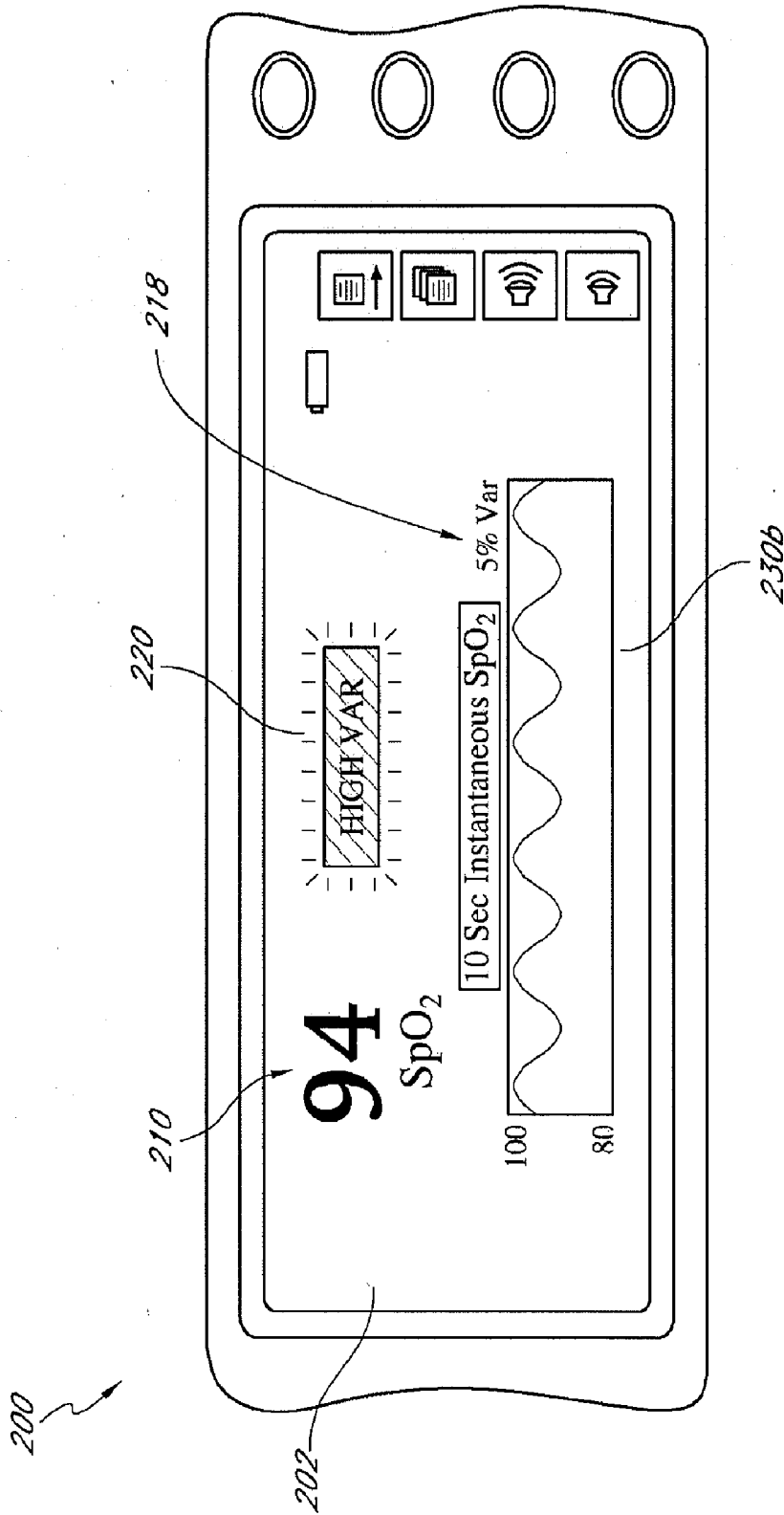

FIG. 3

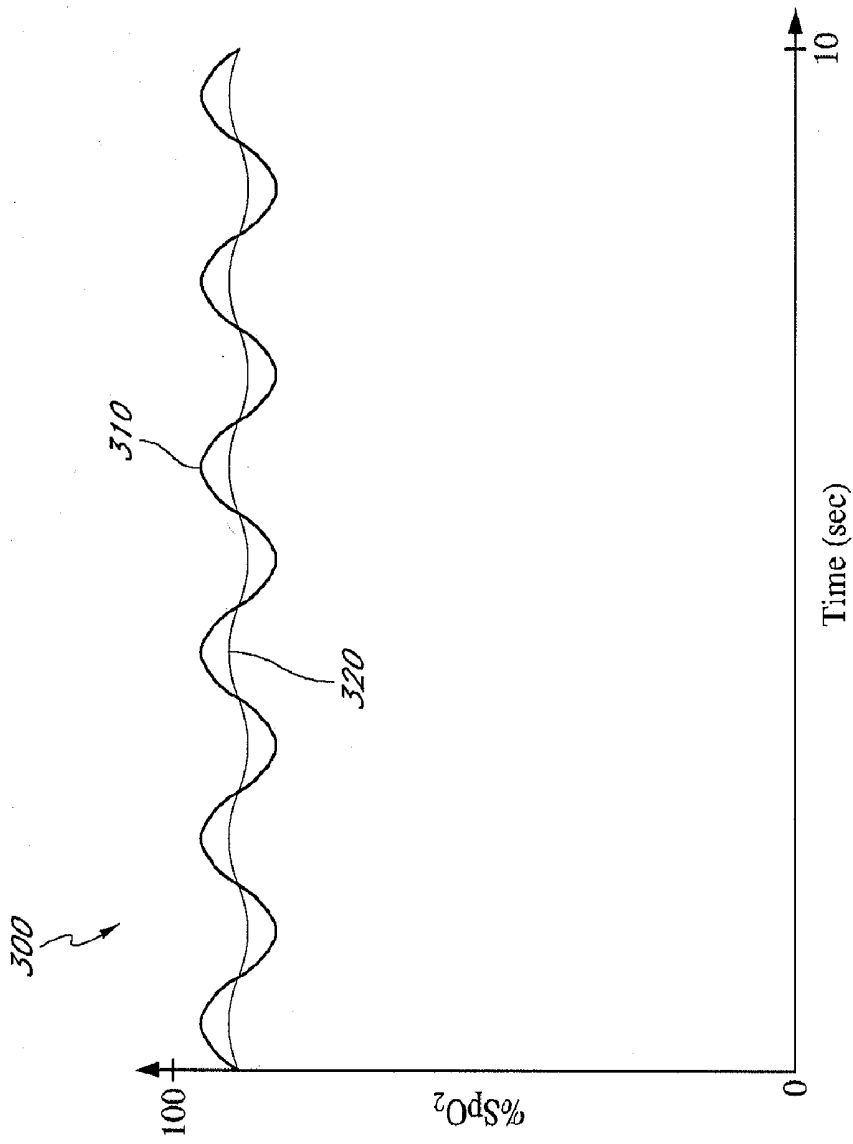

FIG. 4

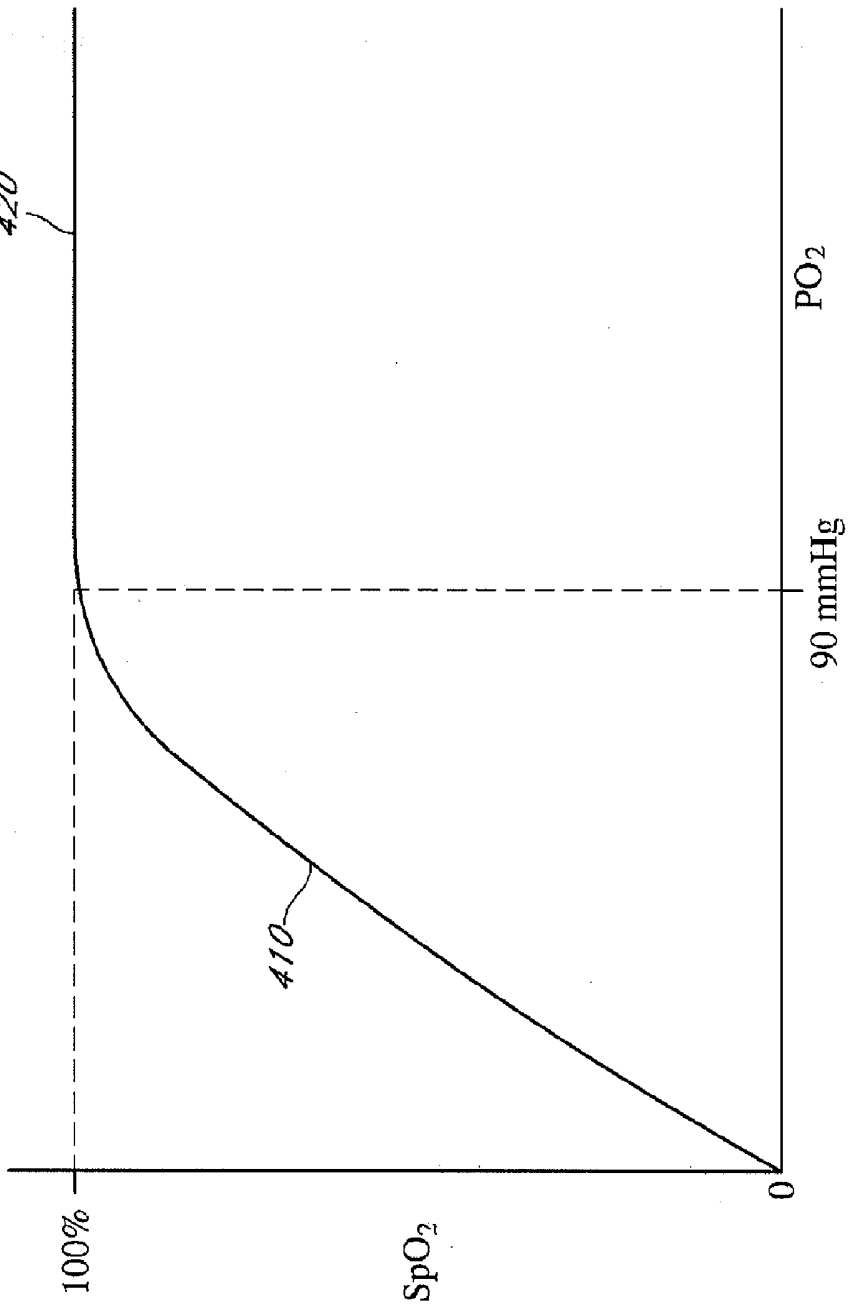

FIG. 5

## PULSE OXIMETRY SYSTEM FOR ADJUSTING MEDICAL VENTILATION

### REFERENCE TO RELATED APPLICATIONS

**[0001]** This application claims priority benefit under 35 U.S.C. §119(e) of U.S. Provisional Application No. 61/222,087 filed Jun. 30, 2009, entitled "Pulse Oximetry System for Adjusting Medical Ventilation." The present application incorporates the disclosure of the foregoing application herein by reference in its entirety.

### FIELD OF INVENTION

**[0002]** The present disclosure relates to patient monitors and medical ventilation.

### BACKGROUND

**[0003]** Hospitals, nursing homes, and other patient care facilities typically include patient monitoring devices at one or more bedsides in the facility. Patient monitoring devices generally include sensors, processing equipment, and displays for obtaining and analyzing a patient's physiological parameters. Physiological parameters include, for example, blood pressure, respiratory rate, oxygen saturation ( $SpO_2$ ) level, other blood constituents and combinations of constituents, and pulse, among others. Clinicians, including doctors, nurses, and certain other caregiver personnel use the physiological parameters obtained from the patient to diagnose illnesses and to prescribe treatments. Clinicians can also use the physiological parameters to monitor a patient during various clinical situations to determine whether to increase the level of care given to the patient. Various patient monitoring devices are commercially available from Masimo Corporation ("Masimo") of Irvine, Calif.

### BRIEF DESCRIPTION OF THE DRAWINGS

**[0004]** FIG. 1 illustrates an embodiment of a patient monitoring system for determining oxygen saturation variability;

**[0005]** FIGS. 2 and 3 illustrate example physiological monitor display providing indications of oxygen saturation variability; and

**[0006]** FIG. 4 illustrates variability of example  $SpO_2$  oxygen saturation waveforms.

**[0007]** FIG. 5 illustrates a graph of  $SpO_2$  versus the partial pressure of oxygen dissolved in the blood,  $PO_2$ .

### DETAILED DESCRIPTION

**[0008]** Medical ventilators are often used to assist patients with breathing. Ventilators can deliver oxygen into a patient's lungs and control the removal of carbon dioxide. Ventilators typically include different settings or parameters that can be adjusted to provide an appropriate amount of ventilation to a patient. These parameters might include, for example, pressure, volume of air provided, and respiration rate. An artisan will recognize from the disclosure herein a wide variety of commercially available ventilator systems, other ventilator systems, and characteristics of ventilator systems known to the ventilator device community.

**[0009]** Significant damage can occur to the lungs, and in particular, to the alveoli structures in the lungs, when ventilation parameters are not appropriate. For instance, too much volume can cause the delicate alveoli to stretch and then collapse, causing injury to the lungs and pulmonary failure.

To avoid this problem, clinicians adjust the ventilation to reduce the distention and collapse the alveoli to prevent lung injury. Thus, a clinician often tries to balance the several ventilation parameters to avoid serious lung damage while providing sufficient air to a patient but not have the alveoli collapse.

**[0010]** This disclosure describes certain systems and methods for indicating when clinicians should consider adjusting ventilation parameters of a medical ventilator. In certain embodiments, a physiological monitor measures at least a patient's blood oxygen saturation noninvasively. The physiological monitor may provide an indication of the amplitude of the difference between a low and high value in the patient's blood oxygen saturation over a predetermined time and/or respiration cycle. A clinician may infer from the indication of the amplitude of the difference of oxygen saturation measurements that adjustment of the ventilation parameters is desired. In response to the clinician adjusting the parameters properly, the amplitude of the differences of the oxygen saturation may advantageously decrease, thereby stabilizing the patient's oxygen and finding the foregoing balance that can ensure proper lung ventilator interactions. The amplitude indication can therefore provide the clinician with feedback that can help advantageously reduce the risk of lung failure.

**[0011]** FIG. 1 illustrates an example patient monitoring system 100. The patient monitoring system 100 may be used to monitor the health status of a patient, including the status of a patient's blood oxygen saturation, although many other parameters may also be monitored. The patient monitoring system 100 can assist a care provider 130 with determining when to adjust ventilator parameters to reduce the risk of lung damage to a patient 102.

**[0012]** In the depicted embodiment, the patient 102 is receiving breathing assistance from a ventilator 150. The patient 102 could receive air from the ventilator 150 through a face mask, intubation tube, or the like. The ventilator 150 may include controls that allow adjustment of ventilation parameters such as inspiratory pressure, air volume, desired respiratory rate, end-expiratory pressure (PEEP), inspiration: expiration ratio (I:E), Fraction of Inspired Oxygen ( $FiO_2$ ), tidal volume (TV), and the like.

**[0013]** The patient 102 is also being monitored by a noninvasive sensor 110. The sensor 110 can be an optical sensor that irradiates a tissue site of the patient 102 with one or more wavelengths of optical radiation. The sensor 110 can detect radiation transmitted through the tissue site of the patient and provide an absorption signal 112 to a physiological monitor 120.

**[0014]** The physiological monitor 120 may have one or more processors that can analyze the absorption signal 112 to determine one or more blood constituents of the patient 102, such as blood oxygen saturation. The physiological monitor 120 can measure oxygen saturation values. The oxygen saturation values measured by the physiological monitor 120 can be somewhat averaged over a respiratory cycle. In other words, in certain embodiments, a shorter averaging time is applied to the oxygen saturation values so as to obtain oxygen saturation values that more closely track actual or instantaneous oxygen saturation over a respiratory cycle. In other embodiments, the physiological monitor 120 does not apply any averaging to the oxygen saturation values.

**[0015]** Advantageously, in certain embodiments, the physiological monitor 120 detects the amplitude of the difference between the highest and lowest oxygen saturation measure-

ments over a set amount of time. Increases and decreases in the oxygen saturation can track or approximately track the patient's **102** respiratory cycle (e.g., a cycle of recruitment and collapse of alveoli). The magnitude of the differences in the oxygen saturation values over time can reflect the degree of recruitment and collapse of alveoli in the respiratory cycle. The physiological monitor **120** can calculate the amplitude of the difference of the lowest and highest values from the set of values included in a window defined by the peak-to-peak oxygen saturation amplitudes with each respiratory cycle or with a selection of respiratory cycles.

**[0016]** In some patients, such as in a ventilated patient **102**, high amplitude of differences of oxygen saturation over each respiratory cycle can reflect overextension of the alveoli of the lungs. This overextension may be caused by too much air pressure or volume followed by too little air pressure or volume. A normal or healthy amplitude of the differences between oxygen saturation high and low values may be, for example, about 2% to about 3% or less, about 1% to about 2% or less, or the like. An amplitude of differences between high and low values that can reflect a risk of lung damage might be greater than about 2% to about 3%, greater than about 4% to about 5%, or the like. Normal and abnormal ranges of the amplitude of oxygen saturation differences can depend on the age of the patient (e.g., neonate versus child versus adult), the gender of the patient, comorbidity of the patient, and the like. When the foregoing measurements show greater amplitude of differences than discussed, particularly when the increases and decreases in oxygen saturation tracks or substantially tracks each respiratory cycle, then ventilation adjustment may advantageously reduce the amplitude of the difference between the high and low values over a respiratory cycle.

**[0017]** The physiological monitor **120** can advantageously provide an indication of the amplitude of the difference in oxygen saturation over a respiratory cycles for presentation to the care provider **130**. For example, the physiological monitor **120** can display oxygen saturation values, an oxygen saturation graph, an amplitude of the differences indicator, combinations of the same, or the like. In some implementations, the physiological monitor **120** outputs an audio and/or visual alarm that alerts the care provider **130** to high amplitude of differences in oxygen saturation high and low values over respiratory cycles. Example monitor **120** displays are described below with respect to FIGS. 2 and 3.

**[0018]** The care provider **130** can use the information provided by the physiological monitor **120** to determine whether to adjust settings **142** of the ventilator **150**. For example, the care provider **130** could adjust one or more of air pressure, air volume, respiratory rate, end-expiratory pressure (PEEP), inspiration: expiration ratio (I:E),  $\text{FiO}_2$ , tidal volume (TV), and the like. In one scenario, if the amplitude of the differences between the high and low values over a respiratory cycle is too high, the care provider **130** might reduce the air pressure and/or air volume provided by the ventilator **150** while increasing the respiratory rate to provide the patient **102** with sufficient air. Adjusting the ventilation parameters could cause the amplitude of the differences in the oxygen saturation to decrease with each respiratory cycle from the previous high amplitude. The physiological monitor **120** could output an indication of the decreased amplitude. The care provider **130** could continue to adjust the ventilation parameters until the physiological monitor **120** reflects a reduced or minimized amplitude of the differences.

**[0019]** In alternative embodiments, the physiological monitor **120** can provide a control signal **126** directly to the ventilator **150** based at least partly on the detected amplitude of the differences in oxygen saturation. The control signal **126** can cause the ventilator **150** to automatically adjust one or more of the ventilation parameters described above. Alternatively, the control signal **126** can cause the ventilator **150** to alarm or to display a recommendation to adjust ventilation parameters on a display of the ventilator **150**, as opposed to fully controlling the ventilator **150**. The physiological monitor **120** can generate this control signal **126** instead of or in addition to providing a saturation value, oxygen saturation graph, indicator, alarm, or the like.

**[0020]** FIG. 2 illustrates an example physiological monitor **200** having a display **202**. The display **202** includes parameter data for oxygen saturation, including a measured value of  $\text{SpO}_2$  **210**, an  $\text{SpO}_2$  graph **230a**, and an amplitude of the differences indicator **218**. The measured value **210** of  $\text{SpO}_2$  can be an  $\text{SpO}_2$  value that is partially averaged over a respiratory cycle or not averaged at all. The  $\text{SpO}_2$  graph **230a** depicts these  $\text{SpO}_2$  values over several respiratory cycles. In the example display **202** shown, the  $\text{SpO}_2$  graph **230a** exemplifies a normal amplitude of differences over a respiratory cycle. A present amplitude of differences of 2% is shown by the amplitude indicator **218**.

**[0021]** FIG. 3 illustrates the example physiological monitor **200** of FIG. 2 when high amplitude of differences between oxygen saturation values occurs over respiratory cycles. As shown, the  $\text{SpO}_2$  graph **230b** depicts a higher amplitude of differences in the oxygen saturation, and the amplitude indicator **218** indicates that 5% amplitude of differences is present.

**[0022]** A visual oxygen saturation alarm **220** is also shown. The oxygen saturation alarm **220** includes text that indicates that the oxygen saturation amplitude of differences is high. The oxygen saturation alarm **220** may be displayed, for example, when a patient's oxygen saturation amplitude of differences increases above a threshold value. The visual oxygen saturation alarm **220** may be accompanied by or be replaced by an audio alarm in certain embodiments. The visual oxygen saturation alarm **220** and/or audible alarm may indicate to a care provider that adjustment to ventilation parameters is desired.

**[0023]** The example display **202** depicted in FIGS. 2 and 3 are merely illustrative. Other displays can include fewer than all the features shown in the display **202**. For instance, the alarm **220** and amplitude indicator **218** may be omitted, and a care provider could make a variability determination solely based on the  $\text{SpO}_2$  graph **230**. Alternatively, the  $\text{SpO}_2$  graph **230** could be omitted, and the alarm **220** and/or indicator **218** may be displayed instead. Many other variations may be provided in other implementations.

**[0024]** FIG. 4 illustrates an example graph **300** that plots oxygen saturation values over time for a patient receiving ventilation. The graph **300** plots an illustrative signal **310** with a relatively higher amplitude of difference and an illustrative signal **320** with a relatively lower amplitude of differences between high and low values over a respiratory cycle. These plots **310**, **320** could be output, for example, by a physiological monitor as oxygen saturation graphs.

**[0025]** The signal **310** with higher amplitude of differences between maximum and minimum values of oxygen saturation over a respiratory cycle can reflect a stressed condition of the patient's lungs, caused by ventilation that is too extreme.

In response to observing the high amplitude of the differences between the high and low values in the signal **310**, a care giver could adjust ventilator parameters as described above. In response, the care giver could adjust the ventilation parameters as needed to maintain a lower amplitude of differences in the signal **320**.

[0026] In an embodiment, one ventilation parameter a caregiver may monitor and adjust to maintain a desired amplitude of the differences in the percentage of oxygen saturation over a respiratory cycle or cycles is the fraction of inspired oxygen ( $\text{FiO}_2$ ). The gases provided to the patient through a ventilator **150** (ventilation gases) may be composed of the types and percentages of gases found in ambient air, or may have different amounts of types of gases. For example, the percentage of oxygen a patient breathes in through a ventilator may be called the fraction of inspired oxygen, or  $\text{FiO}_2$ . Specifically, increased  $\text{FiO}_2$  may be administered in order to maintain a patient's oxygen saturation within certain ranges.

[0027] In order for a caregiver to maintain adequate oxygen saturation by maintaining an appropriate  $\text{FiO}_2$  to a patient, the oxygen saturation can be monitored according to the methods disclosed herein and the  $\text{FiO}_2$  can be adjusted accordingly. FIG. 5 illustrates a graph of  $\text{SpO}_2$  versus the partial pressure of oxygen dissolved in the blood,  $\text{PO}_2$ . This graph illustrates the relationship between the percentage of hemoglobin in the blood bound to oxygen to the partial pressure of oxygen dissolved in the blood. As the partial pressure of oxygen in the blood increases the increase the percentage of oxygen saturation of the hemoglobin will increase.

[0028] When the partial pressure of oxygen in the blood reaches about 90 mmHg, the oxygen saturation of the hemoglobin will plateau at 100 percent oxygen saturation. If the partial pressure of oxygen in the blood is increased to about 90 mmHg, the oxygen saturation will stay 100 percent saturated, and will not increase as no more oxygen may bind to the hemoglobin. This leaves a large range of partial pressures of oxygen dissolved in the blood that will result in an oxygen saturation of the hemoglobin at 100 percent. Therefore, this illustrates that the partial pressure of oxygen in the blood will affect the oxygen saturation of the hemoglobin.

[0029] Therefore, a caregiver may control the partial pressure of oxygen in the blood in order to manipulate or control the oxygen saturation of the hemoglobin. One way to do this is to manipulate the  $\text{FiO}_2$  or fraction of inspired oxygen to a patient. When a caregiver increases the fraction of inspired oxygen to a patient, the partial pressure of oxygen in the alveolar sacs will increase. This will cause more of the oxygen in the lungs to be dissolved into the blood of the arteries, which may or may not bind to hemoglobin, depending on the  $\text{SpO}_2$  level. Similarly, if a caregiver decreases the fraction of inspired oxygen the partial pressure of oxygen in the blood will decrease.

[0030] A caregiver may only change or manipulate the  $\text{SpO}_2$  or oxygen saturation of the hemoglobin, if the partial pressure of oxygen is low enough so that the oxygen saturation is less than 100 percent saturated. Otherwise if the  $\text{SpO}_2$  is 100 percent, and the partial pressure of the oxygen in a patient's blood is on the flat portion of the graph marked **420**, changes in the partial pressure of oxygen dissolved in the blood will have no effect on the  $\text{SpO}_2$  and therefore changes in the  $\text{FiO}_2$  or the fraction of oxygen inspired by a patient will not effect or change the level of  $\text{SpO}_2$ . Similarly if the patient's  $\text{PO}_2$  is in the range marked **420**, the patient's  $\text{SpO}_2$  will remain

constant, and therefore changes in the  $\text{SpO}_2$  due to the respiratory cycle (or other non- $\text{FiO}_2$  related changes) will not be observable.

[0031] Therefore, in order to utilize  $\text{FiO}_2$  to control  $\text{SpO}_2$  the  $\text{FiO}_2$  must be decreased until the  $\text{SpO}_2$  levels fall below 100 percent. This will place the  $\text{SpO}_2$  on the portion of the graph marked **410** where changes in the  $\text{FiO}_2$  will produce changes in the  $\text{SpO}_2$  of a patient. This will allow a caregiver to monitor the changes in the  $\text{SpO}_2$  levels and adjust the levels by changing the  $\text{FiO}_2$  that is delivered to a patient.

[0032] In an embodiment, in order limit the amplitude in the difference of the  $\text{SpO}_2$  over the course of the respiration cycle, it may be advantageous to control the  $\text{FiO}_2$  delivered to a patient on the ventilator **150** so that it corresponds or stays within the range of the  $\text{FiO}_2$  values on the part of the slope of the graph marked **410** in FIG. 5. In order to do this, the  $\text{FiO}_2$  could begin at a value that provides an  $\text{SpO}_2$  value of or near 100 percent generally within the range of the graph marked **420**. Next, the  $\text{FiO}_2$  could be lowered until the  $\text{SpO}_2$  falls within a range known by persons of skill in the art to be on the part of the curve marked **410**, while still providing a safe and adequate blood oxygenation level. Thereafter, a servo mechanism could raise the  $\text{FiO}_2$  when it begins to decrease further, and lower the  $\text{FiO}_2$  as soon as it begins to increase and then again raise the  $\text{FiO}_2$  as soon as the  $\text{SpO}_2$  begins to decrease, and so on. In another embodiment, other controls known in the art may keep the  $\text{SpO}_2$  within a range that corresponds to a portion of the curve marked **410** by controlling the  $\text{FiO}_2$  through any mechanisms or controls known in the art. In an embodiment, this range may be between 80-99, 85-99, 91-99, 91-97, 92-98, 93-97, 92-99, 95-97, or 96-97 percent  $\text{SpO}_2$  or any other percentages of  $\text{SpO}_2$  known in the art to be safe and withing the portion of the curve marked as **410** in FIG. 5.

[0033] FIG. 1 illustrates an embodiment of a physiological monitor **120** set up to provide an optimal  $\text{FiO}_2$  to a patient. The ventilator **150** provides ventilation gas to the patient and can vary the  $\text{FiO}_2$  of the ventilation gas provided to the patient. In an embodiment, the ventilator **150** may also be connected to the physiological monitor **120**. In an embodiment, the physiological monitor **120** could provide information regarding the oxygen saturation or  $\text{SpO}_2$  detected from the patient and send to the ventilator **150** to determine whether the  $\text{FiO}_2$  should be increased or decreased or held constant. In another embodiment, the physiological monitor **120** could determine, based on the oxygen saturation or  $\text{SpO}_2$ , whether the  $\text{FiO}_2$  should be increased or decreased or held constant and send a corresponding command signal through the control **126** to the ventilator **150**. In an embodiment, the command signal could be a simple data message indicating the amount the  $\text{FiO}_2$  should be increased or decreased.

[0034] Additional embodiments of using pulse oximetry to adjust ventilator parameters are described in the attached Appendices, which is to be considered a part of this application.

[0035] Conditional language used herein, such as, among others, "can," "could," "might," "may," "e.g.," and the like, unless specifically stated otherwise, or otherwise understood within the context as used, is generally intended to convey that certain embodiments may include, while other embodiments may not include, certain features, elements and/or steps. Thus, such conditional language is not generally intended to imply that features, elements and/or steps are in any way required for one or more embodiments or that one or more embodiments necessarily include logic for deciding,

with or without user input or prompting, whether these features, elements and/or steps are included or are to be performed in any particular embodiment.

**[0036]** Depending on the embodiment, certain acts, events, or functions of any of the methods described herein can be performed in a different sequence, may be added, merged, or left out all together (e.g., not all described acts or events are necessary for the practice of the method). Moreover, in certain embodiments, acts or events may be performed concurrently, e.g., through multi-threaded processing, interrupt processing, or multiple processors or processor cores, rather than sequentially.

**[0037]** The various illustrative logical blocks, modules, circuits, and algorithm steps described in connection with the embodiments disclosed herein may be implemented as electronic hardware, computer software, or combinations of both. To clearly illustrate this interchangeability of hardware and software, various illustrative components, blocks, modules, circuits, and steps have been described above generally in terms of their functionality. Whether such functionality is implemented as hardware or software depends upon the particular application and design constraints imposed on the overall system. The described functionality may be implemented in varying ways for each particular application, but such implementation decisions should not be interpreted as causing a departure from the scope of the disclosure.

**[0038]** While the above detailed description has shown, described, and pointed out novel features as applied to various embodiments, it will be understood that various omissions, substitutions, and changes in the form and details of the device or process illustrated may be made without departing from the spirit of the disclosure. As will be recognized, certain embodiments of the inventions described herein may be embodied within a form that does not provide all of the features and benefits set forth herein, as some features may be used or practiced separately from others. The scope of certain inventions disclosed herein is indicated by the appended claims rather than by the foregoing description. All changes which come within the meaning and range of equivalency of the claims are to be embraced within their scope.

What is claimed is:

1. A noninvasive method of analyzing the amplitude of the differences in oxygen saturation of a patient, the method comprising:

deriving oxygen saturation values from a patient, the oxygen saturation values reflecting oxygen saturation of blood at a tissue site; and

outputting an indication of the amplitude of the differences in the oxygen saturation values per respiratory cycle.

2. The method of claim 1, wherein the amplitude of the differences in the oxygen saturation reflects a health status of the lungs of the patient.

3. The method of claim 1, wherein the amplitude of the differences tracks a respiratory cycle of the patient.

4. The method of claim 1, wherein said outputting the indication of amplitude of the differences comprises outputting a graph of oxygen saturation values.

5. The method of claim 1, wherein said outputting the indication of amplitude of the differences comprises outputting a percentage value of variability.

6. The method of claim 1, further comprising determining whether the amplitude of the differences in the oxygen saturation is above a threshold value.

7. The method of claim 1, wherein said outputting the indication of amplitude of the differences comprises generating an alarm in response to the variability being above the threshold value.

8. The method of claim 1, further comprising providing a control signal to a ventilator responsive to the amplitude of the differences in oxygen saturation.

9. The method of claim 1, wherein the control signal to the ventilator increases or decreases an  $\text{FiO}_2$  amount delivered by the ventilator to the patient

10. The method of claim 9, wherein the  $\text{FiO}_2$  amount is increased or decreased to keep the patient's oxygen saturation values on a steep part of a  $\text{SpO}_2$  versus  $\text{FiO}_2$  curve of the patient.

11. A physiological monitoring system, the system comprising:

a physiological monitor comprising one or more processors configured to:

derive oxygen saturation values from a patient, the oxygen saturation values corresponding to values of oxygen saturation in blood at a tissue site, and

output an indication of the amplitude of the differences per respiratory cycle in the oxygen saturation values.

12. The system of claim 11, wherein the amplitude of the differences in the oxygen saturation reflects a health status of the lungs of the patient.

13. The system of claim 11, wherein the amplitude of the differences tracks a respiratory cycle of the patient.

14. The system of claim 11, wherein the physiological monitor is further configured to output the indication of amplitude of the differences by at least outputting a graph of oxygen saturation values.

15. The system of claim 11, wherein the physiological monitor is further configured to output the indication of amplitude of the differences by at least outputting a percentage value of amplitude of the differences.

16. The system of claim 11, the physiological monitor is further configured to determine whether the amplitude of the differences in the oxygen saturation is above a threshold value.

17. The system of claim 16, wherein the physiological monitor is further configured to output the indication of amplitude of the differences by at least generating an alarm in response to the amplitude of the differences being above the threshold value.

18. The system of claim 11, physiological monitor is further configured to provide a control signal to a ventilator responsive to the amplitude of the differences in oxygen saturation.

19. The system of claim 18, wherein the control signal to a ventilator increases or decreases an  $\text{FiO}_2$  amount delivered to the patient.

20. The system of claim 19, wherein the  $\text{FiO}_2$  amount is increased or decreased to keep the patient's oxygen saturation values on a steep part of a  $\text{SpO}_2$  versus  $\text{FiO}_2$  curve of the patient.

21. The system of claim 11, wherein the physiological monitor is further configured to derive the oxygen saturation values from a physiological signal obtained by a noninvasive optical sensor.

专利名称(译)	脉搏血氧仪调整医用通气系统		
公开(公告)号	<a href="#">US20100331639A1</a>	公开(公告)日	2010-12-30
申请号	US12/824087	申请日	2010-06-25
[标]申请(专利权)人(译)	奥莱利MICHAEL		
申请(专利权)人(译)	MICHAEL O'REILLY		
当前申请(专利权)人(译)	MICHAEL O'REILLY		
[标]发明人	OREILLY MICHAEL		
发明人	O'REILLY, MICHAEL		
IPC分类号	A61B5/00		
CPC分类号	A61B5/14551 A61M16/0051 A61M2230/205 A61M2230/005 A61M16/024		
优先权	61/222087 2009-06-30 US		
其他公开文献	US8670811		
外部链接	<a href="#">Espacenet</a> <a href="#">USPTO</a>		

摘要(译)

生理监测系统可以包括具有一个或多个处理器的生理监测器，所述处理器可以从患者获得氧饱和度值。氧饱和度值可以对应于患者组织部位的血液中的氧饱和度值。生理监测器可输出氧饱和度值中每呼吸周期的差异幅度的指示。

