



US007197357B2

(12) **United States Patent**  
**Istvan et al.**

(10) **Patent No.:** **US 7,197,357 B2**  
(45) **Date of Patent:** **Mar. 27, 2007**

(54) **WIRELESS ECG SYSTEM**

3,199,508 A 8/1965 Roth  
3,495,584 A 2/1970 Schwalm

(75) Inventors: **Rud Istvan**, Fort Lauderdale, FL (US);  
**Bill Gregory**, Fort Lauderdale, FL  
(US); **Kenneth Solovay**, Weston, FL  
(US); **David Paul Chastain**, Acton, MA  
(US); **John David Gundlach**, Acton,  
MA (US); **Nicholas C. Hopman**, Lake  
Zurich, IL (US); **Daniel L. Williams**,  
Norwell, MA (US); **Franco Lodato**,  
Weston, FL (US); **Michael Salem**, Ft.  
Lauderdale, FL (US)

(Continued)

**FOREIGN PATENT DOCUMENTS**

DE 1805444 5/1970  
DE 2535858 2/1976  
DE 3732714 4/1989

(Continued)

**OTHER PUBLICATIONS**

(73) Assignee: **Life Sync Corporation**, Fort  
Lauderdale, FL (US)

(\*) Notice: Subject to any disclaimer, the term of this  
patent is extended or adjusted under 35  
U.S.C. 154(b) by 0 days.

(21) Appl. No.: **09/998,733**

(22) Filed: **Nov. 30, 2001**

(65) **Prior Publication Data**

US 2003/0105403 A1 Jun. 5, 2003

**Related U.S. Application Data**

(63) Continuation-in-part of application No. 09/908,509, filed on  
Jul. 17, 2001, now Pat. No. 6,611,705.

(51) **Int. Cl.**  
**A61B 5/04** (2006.01)

(52) **U.S. Cl.** ..... **600/509**

(58) **Field of Classification Search** ..... 600/509,  
600/512, 301, 372, 382, 386-391, 393, 523;  
128/903

See application file for complete search history.

(56) **References Cited**

**U.S. PATENT DOCUMENTS**

2,958,781 A 11/1960 Marchal et al.

Kimmich, H.,P., "Clinical Telemetry and Patient Monitoring", Biotelemetry II: Proceedings of the Second International Symposium on Biotelemetry, 1974, pp. 190-195, Switzerland.

Zerzawy, R., "Simultaneous Wireless Telemetry for Several Biologic Measurements. Technics and Application of a New 4-Channel Telemetry", periodical—Z Kreislaufforsch, Feb. 1971, pp 162-169, vol. 60 part 2.

Retzke, F., "Experience with a Mobile Monitoring System for Fetal and Neonatal Cardiotachometry", periodical—Zentrabl Gynakol, 1984, pp 545-549, vol. 106.

Van Rijn, A.C.M., "Modelling of Biopotential Recordings and It's Implications for Instrumentation Design", doctoral thesis—available from the National Technical Information Service, Springfield, VA., Nov. 8, 1993, 153 pages.

(Continued)

*Primary Examiner*—George Manuel

*Assistant Examiner*—Dana D. Greene

(74) *Attorney, Agent, or Firm*—Lott & Friedland, P.A.

(57) **ABSTRACT**

A cardiac monitoring system and, more particularly, a wireless electrocardiograph (ECG) system. The present invention detects electrical signals from a patient's heart and transmits the signals digitally to a remote base station via telemetry. The base station converts the digital signals back to an analog electrical signals that can be read by an ECG monitor.

**25 Claims, 13 Drawing Sheets**

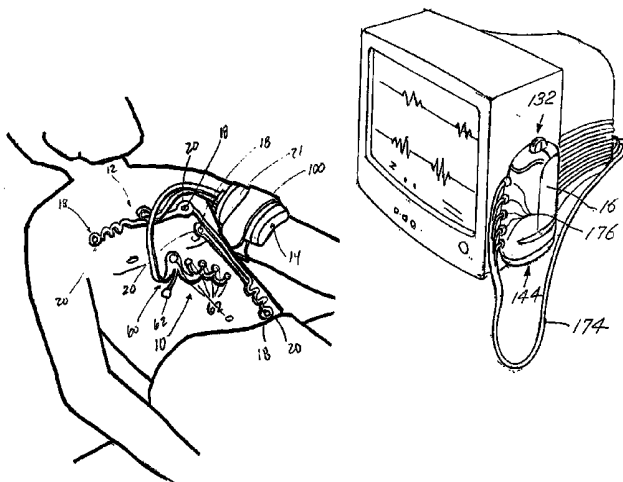

U.S. PATENT DOCUMENTS			
3,602,215 A	8/1971	Parnell	4,784,162 A 11/1988 Ricks et al.
3,603,881 A	9/1971	Thornton	4,791,933 A 12/1988 Asai et al.
3,727,190 A	4/1973	Vogelman	4,794,532 A 12/1988 Leckband et al.
3,729,708 A	4/1973	Wolfer	4,799,059 A 1/1989 Grindahl
3,757,778 A	9/1973	Graham	4,802,222 A 1/1989 Weaver
3,774,594 A	11/1973	Huszar	4,803,625 A 2/1989 Fu et al.
3,810,102 A	5/1974	Parks, III	4,805,631 A 2/1989 Roi du Maroc, II.
3,830,228 A	8/1974	Foner	4,835,372 A 5/1989 Gombrich
3,834,373 A	9/1974	Sato	4,839,806 A 6/1989 Goldfischer
3,905,364 A	9/1975	Cudahy	4,850,009 A 7/1989 Zook
3,910,260 A	10/1975	Sarnoff	4,852,572 A 8/1989 Nakahashi et al.
3,925,762 A	12/1975	Heitlinger	4,860,759 A 8/1989 Kahn et al.
3,943,918 A *	3/1976	Lewis ..... 600/392	4,865,044 A 9/1989 Wallace
3,970,996 A	7/1976	Yasaka	4,883,064 A 11/1989 Olson
3,986,498 A	10/1976	Lewis	4,889,131 A 12/1989 Salem et al.
4,027,663 A	6/1977	Fischler	4,889,132 A 12/1989 Hutcheson
4,042,906 A	8/1977	Ezell	4,909,260 A 3/1990 Salem et al.
4,051,522 A	9/1977	Healy	4,916,441 A 4/1990 Gombrich
4,074,228 A	2/1978	Jonscher	4,928,187 A 5/1990 Rees
4,121,573 A	10/1978	Crovella et al.	4,955,075 A 9/1990 Anderson
4,124,894 A	11/1978	Vick	4,957,109 A 9/1990 Groeger et al.
4,141,351 A	2/1979	James et al.	4,958,645 A 9/1990 Cadell et al.
4,150,284 A	4/1979	Trenkler et al.	4,966,154 A 10/1990 Cooper et al.
4,156,867 A	5/1979	Bench	4,974,607 A 12/1990 Miwa
4,173,221 A	11/1979	McLaughlin	4,981,141 A 1/1991 Segalowitz
4,173,971 A	11/1979	Karz	5,012,411 A 4/1991 Policastro et al.
4,186,749 A	2/1980	Fryer	5,025,452 A 6/1991 Sohner
4,216,462 A	8/1980	McGrath	5,025,808 A 6/1991 Hafner
4,233,241 A	11/1980	Kalopissis	5,026,462 A 6/1991 Butterfield et al.
4,237,900 A	12/1980	Schulman et al.	5,036,869 A 8/1991 Inahara
4,260,951 A	4/1981	Lewyn	5,042,498 A 8/1991 Dukes
4,262,632 A	4/1981	Hanton	5,051,799 A 9/1991 Paul et al.
4,281,664 A	8/1981	Duggan	5,072,383 A 12/1991 Brimm
4,321,933 A	3/1982	Baessler	5,077,753 A 12/1991 Grau
4,328,814 A	5/1982	Arkans	5,078,134 A 1/1992 Heilman
4,353,372 A	10/1982	Ayer	5,085,224 A 2/1992 Galen
4,396,906 A	8/1983	Weaver	5,109,845 A 5/1992 Yuuchi et al.
4,425,921 A	1/1984	Fujisaki	5,113,869 A 5/1992 Nappholz et al.
4,441,498 A	4/1984	Nordling	5,127,404 A 7/1992 Wyborny
4,449,536 A	5/1984	Weaver	5,131,399 A 7/1992 Sciarra
4,471,786 A	9/1984	Inagaki et al.	5,137,022 A 8/1992 Henry
4,475,208 A	10/1984	Ricketts	5,153,584 A 10/1992 Engira
4,494,552 A	1/1985	Heath	5,157,604 A 10/1992 Axford
4,510,495 A	4/1985	Sigrimis	5,168,874 A 12/1992 Segalowitz
4,521,918 A	6/1985	Challen	5,171,977 A 12/1992 Morrison
4,531,526 A	7/1985	Genest	5,177,765 A 1/1993 Holland
4,539,995 A	9/1985	Segawa	5,177,766 A 1/1993 Holland
4,556,061 A	12/1985	Barreras et al.	5,179,569 A 1/1993 Sawyer
4,556,063 A	12/1985	Thompson et al.	5,179,571 A 1/1993 Schilling
4,562,840 A	1/1986	Batina et al.	5,181,519 A 1/1993 Bible
4,573,026 A	2/1986	Curtis	5,184,620 A 2/1993 Cudahy
4,583,548 A	4/1986	Schmid	5,191,886 A * 3/1993 Paeth et al. .... 600/382
4,583,549 A	4/1986	Manoli	5,192,949 A 3/1993 Suzuki
4,585,004 A	4/1986	Brownlee	5,205,294 A 4/1993 Flach et al.
4,586,508 A	5/1986	Batina et al.	5,212,476 A 5/1993 Maloney
4,598,281 A	7/1986	Maas	5,212,715 A 5/1993 Pickert
4,599,723 A	7/1986	Eck	5,224,479 A 7/1993 Sekine
4,601,043 A	7/1986	Hardt	5,224,485 A 7/1993 Powers
4,606,352 A	8/1986	Geddes	5,226,431 A 7/1993 Bible et al.
4,608,987 A	9/1986	Mills	5,238,001 A 8/1993 Gallant et al.
4,618,861 A	10/1986	Gettens et al.	5,270,811 A 12/1993 Ishibashi
4,625,733 A	12/1986	Saynajakangas	5,272,477 A 12/1993 Tashima
RE32,361 E	2/1987	Duggan	5,292,343 A 3/1994 Blanchette
4,653,068 A	3/1987	Kadin	5,305,202 A 4/1994 Gallant
4,681,118 A	7/1987	Asai et al.	5,305,353 A 4/1994 Weerackody
4,709,704 A	12/1987	Lukasiewicz	5,307,372 A 4/1994 Sawyer
4,724,435 A	2/1988	Moses	5,307,817 A 5/1994 Guggenbuhl
4,747,413 A	5/1988	Bloch	5,307,818 A * 5/1994 Segalowitz ..... 600/509
4,754,483 A	6/1988	Weaver	5,309,920 A 5/1994 Gallant et al.
4,783,844 A	11/1988	Higashiyama et al.	5,314,450 A 5/1994 Thompson
			5,319,363 A 6/1994 Welch et al.

US 7,197,357 B2

5,327,888 A	7/1994	Imran		5,759,199 A	6/1998	Snell et al.	
5,335,664 A	8/1994	Nagashima		5,767,791 A	6/1998	Stoop et al.	
5,339,824 A	* 8/1994	Engira .....	600/525	5,776,057 A	7/1998	Swenson	
5,341,806 A	8/1994	Gadsby et al.		5,779,630 A	7/1998	Fein	
5,342,408 A	8/1994	deCoriolis		5,782,238 A	7/1998	Beitler	
5,343,869 A	9/1994	Pross		5,788,633 A	8/1998	Mahoney	
5,343,870 A	9/1994	Gallant et al.		5,800,204 A	9/1998	Nitsu	
5,348,008 A	9/1994	Bornn et al.		5,813,404 A	9/1998	Devlin	
5,353,791 A	10/1994	Tamura		5,819,740 A	10/1998	Muhlenberg	
5,353,793 A	10/1994	Bornn		5,820,567 A	10/1998	Mackie	
5,354,319 A	10/1994	Wyborny		5,827,179 A	10/1998	Lichter	
5,359,641 A	10/1994	Schull		5,855,550 A	1/1999	Lai	
5,365,530 A	11/1994	Yoshida		5,862,803 A	1/1999	Besson et al.	
5,375,604 A	12/1994	Kelly et al.		5,865,733 A	2/1999	Malinouskas et al.	
5,377,222 A	12/1994	Sanderford, Jr.		5,865,741 A	2/1999	Kelly et al.	
5,381,798 A	1/1995	Burrows		5,868,671 A	2/1999	Mahoney	
5,392,771 A	2/1995	Mock		5,871,451 A	2/1999	Unger et al.	
5,394,882 A	3/1995	Mawhinney		5,873,369 A	2/1999	Laniado	
5,400,794 A	3/1995	Gorman		5,873,821 A	2/1999	Chance et al.	
5,417,222 A	5/1995	Dempsey		5,882,300 A	3/1999	Malinouskas et al.	
5,438,607 A	8/1995	Pzygoda		5,899,928 A	5/1999	Sholder et al.	
5,441,047 A	8/1995	David et al.		5,899,931 A	5/1999	Deschamp et al.	
5,444,719 A	8/1995	Cox et al.		5,907,291 A	5/1999	Chen et al.	
5,458,122 A	10/1995	Hethuin		5,913,827 A	6/1999	Gorman	
5,458,123 A	10/1995	Unger		5,916,159 A	6/1999	Kelly et al.	
5,458,124 A	10/1995	Stanko et al.		5,917,414 A	6/1999	Oppelt	
5,464,021 A	11/1995	Birnbaum		5,919,141 A	7/1999	Money et al.	
5,485,848 A	1/1996	Jackson et al.		5,919,214 A	7/1999	Ciciarelli et al.	
5,491,474 A	2/1996	Suni et al.		5,931,791 A	8/1999	Saltzstein	
5,507,035 A	4/1996	Bantz		5,935,078 A	8/1999	Feierbach	
5,511,553 A	4/1996	Segalowitz		5,938,597 A	8/1999	Stratbucker	
5,522,396 A	6/1996	Langer et al.		5,944,659 A	8/1999	Flach et al.	
5,524,637 A	6/1996	Erickson		5,949,352 A	9/1999	Ferrari	
5,538,007 A	7/1996	Gorman		5,954,536 A	9/1999	Fuerst et al.	
5,544,649 A	8/1996	David et al.		5,954,719 A	9/1999	Chen et al.	
5,544,661 A	8/1996	Davis et al.		5,957,854 A	9/1999	Besson et al.	
5,546,950 A	8/1996	Schoeckert et al.		5,959,529 A	9/1999	Kail, IV	
5,549,113 A	8/1996	Halleck et al.		5,961,448 A	10/1999	Swenson	
5,564,429 A	10/1996	Bornn		5,963,650 A	10/1999	Simionescu et al.	
5,568,814 A	10/1996	Gallant et al.		5,964,701 A	10/1999	Asada et al.	
5,575,284 A	11/1996	Athan et al.		5,970,105 A	10/1999	Dacus	
5,576,952 A	11/1996	Stutman		5,999,857 A	12/1999	Weijand et al.	
5,579,001 A	11/1996	Dempsey		6,009,350 A	12/1999	Renken	
5,579,378 A	11/1996	Arlinghaus		6,010,359 A	1/2000	Etters et al.	
5,579,775 A	12/1996	Iempsey		6,027,363 A	2/2000	Watt et al.	
5,579,781 A	12/1996	Cooke		6,039,600 A	3/2000	Etters et al.	
5,582,180 A	12/1996	Manset		6,047,201 A	4/2000	Jackson, III	
5,586,552 A	12/1996	Sakai		6,053,887 A	4/2000	Levitas	
5,617,871 A	4/1997	Burrows		6,055,448 A	4/2000	Anderson et al.	
5,623,925 A	4/1997	Swenson		6,057,758 A	5/2000	Dempsey et al.	
5,628,324 A	5/1997	Sarbach		6,066,093 A	5/2000	Kelly	
5,628,326 A	5/1997	Arand et al.		6,074,345 A	6/2000	van Oostrom et al.	
5,634,468 A	6/1997	Platt et al.		6,076,003 A	* 6/2000	Rogel .....	600/390
5,640,953 A	6/1997	Bishop		6,077,124 A	6/2000	Etters et al.	
5,645,059 A	7/1997	Fein et al.		6,083,248 A	7/2000	Thompson	
5,645,571 A	* 7/1997	Olson et al. ....	607/5	6,086,412 A	7/2000	Watt et al.	
5,646,701 A	7/1997	Duckworth		6,093,146 A	7/2000	Filangeri	
5,664,270 A	9/1997	Bell		6,102,856 A	8/2000	Groff et al.	
5,669,391 A	9/1997	Williams		6,115,622 A	* 9/2000	Minoz .....	600/361
5,678,545 A	10/1997	Stratbucker		6,117,076 A	9/2000	Cassidy	
5,678,562 A	10/1997	Sellers		6,119,029 A	* 9/2000	Williams .....	600/361
5,685,303 A	11/1997	Rollman		6,139,495 A	* 10/2000	De La Huerga .....	600/300
5,690,119 A	11/1997	Rytky et al.		6,141,575 A	10/2000	Price	
5,694,940 A	12/1997	Unger et al.		6,146,190 A	11/2000	Fuerst et al.	
5,704,351 A	1/1998	Mortara et al.		6,147,618 A	11/2000	Halleck	
5,718,234 A	2/1998	Warden et al.		6,149,602 A	11/2000	Arcelus	
5,720,771 A	2/1998	Snell		6,150,951 A	* 11/2000	Olejniczak .....	340/2.8
5,738,102 A	4/1998	Lemelson		6,154,676 A	11/2000	Levine	
5,746,207 A	* 5/1998	McLaughlin et al. ....	600/372	6,157,851 A	12/2000	Kelly et al.	
5,748,103 A	5/1998	Flach et al.		6,198,394 B1	3/2001	Jacobsen	
5,755,230 A	5/1998	Schmidt et al.		6,206,837 B1	3/2001	Brugnoli	

6,213,942	B1	4/2001	Flach et al.	
6,219,568	B1	4/2001	Kelly et al.	
6,219,569	B1	4/2001	Kelly et al.	
6,225,901	B1	5/2001	Kail	
6,236,874	B1	5/2001	Devlin	
6,238,338	B1	5/2001	DeLuca et al.	
6,244,890	B1	6/2001	Fuerst et al.	
6,259,939	B1	7/2001	Rogel .....	600/390
6,267,723	B1	7/2001	Matsumura	
6,287,252	B1	9/2001	Lugo	
6,289,238	B1	9/2001	Besson	
6,295,466	B1	9/2001	Ishikawa et al.	
6,304,774	B1	10/2001	Gorman	
6,319,200	B1	11/2001	Lai	
6,332,094	B1	12/2001	Gorman	
6,364,834	B1	4/2002	Reuss	
6,389,308	B1	5/2002	Shusterman	
6,408,200	B1	6/2002	Takashina	
6,415,169	B1	7/2002	Kornrumpf et al.	
6,416,471	B1	7/2002	Kumar	
6,440,067	B1	8/2002	DeLuca	
6,441,747	B1	8/2002	Khair	
6,443,890	B1	9/2002	Schulze et al.	
6,450,953	B1	9/2002	Place	
6,453,186	B1	9/2002	Lovejoy et al.	
6,454,708	B1	9/2002	Ferguson et al.	
6,470,893	B1	10/2002	Boesen	
6,480,733	B1	11/2002	Turcott	
6,496,705	B1	12/2002	Ng	
6,544,173	B2	4/2003	West et al.	
6,544,174	B2	4/2003	West et al.	
6,560,473	B2	5/2003	Dominguez	
6,602,191	B2	8/2003	Quy	
6,616,606	B1	9/2003	Petersen et al.	
6,654,631	B1	11/2003	Sahai	
6,694,180	B1	2/2004	Boesen	

FOREIGN PATENT DOCUMENTS

DE	4034019	7/1992
EP	0212278	3/1987
EP	0354251	2/1990
EP	0719108	7/1996
EP	880 936 A2	12/1998
FR	0 048 187 A1	7/1981
JP	5-329121	6/1992
JP	5-220119	8/1993
JP	5-298589	11/1993
JP	5-329120	12/1993
JP	H05 334458	12/1993
JP	H09-19409	1/1997
WO	WO 87/06113	10/1987
WO	WO 90/08501	9/1990
WO	WO9401039	1/1994
WO	WO 95/07048	3/1995
WO	WO9516388	6/1995
WO	WO 97/49077	12/1997
WO	WO 00/62663	10/2000
WO	WO 00/62664	10/2000
WO	WO 00/62665	10/2000
WO	WO0062667	10/2000
WO	WO 00/62667	10/2000
WO	WO 01/89362	11/2001

OTHER PUBLICATIONS

Niitani, H., "Telemetry with Special Reference to Wireless Transmission of Electrocardiogram", periodical—Nippon Rinsho, Dec. 1969, pp 2873–2882, vol. 27 part 12.

Kimmich, H.P., "Biotelemetry in Anesthesia and Intensive Care", periodical—Anesth Analg (Paris), 1979, pp 383–387, vol. 36 part 9–10.

Henne, B., "Comparison Between Wilson's Thoracic Leads and the Telemetrically Transmitted Lead CM6 in Patients with Heart Diseases During Exertion", periodical—Z Kardiol, Mar. 1975, pp 274–280, vol. 64 part 3.

Baumgarten, K., "Wireless Transmission of the Fetal Electrocardiogram and Fetal Heart Beat During Pregnancy and Labor", periodical—Arch Gynakol, 1967, pp 267–268, vol. 204 part 2.

Muller, S., "Multifrequency Selective RF Pulses for Multi-slice MR Imaging", periodical—Magnetic Resonancy in Medicine, 1988, pp 364–372, vol. 6 part 3.

Harlow, H.J., "Adrenal Responsiveness in Domestic Sheep (Ovis aries) to Acute and Chronic Stressors as Predicted by Remote Monitoring of Cardiac Frequency", periodical—Canadian Journal of Zoology, 1987, pp 2021–2027, vol. 65 part 8.

Spraggins, T.A., "Wireless Retrospective Gating: Application to Cine Cardiac Imaging", periodical—Magnetic Resonance Imaging, 1990, pp 675–681, vol. 8 part 6.

White, R.D., "Electrocardiograph—Independent, "Wireless" Cardiovascular Cine MR Imaging", periodical—Magnetic Resonance Imaging, May–Jun. 1991, pp 347–355, vol. 1 part 3.

Watkinson, W.P., "Improved technique for Monitoring Electrocardiograms During Exposure to Radio-Frequency Radiation", periodical—AM J Physiological Society, 1986, pp H320–324, vol. 250 part 2.

Annovazzi-Lodi, Valerio, "Optoelectronic Telemetry of Electrophysiological Signals", periodical—Proceedings of SPIE, 1990, pp 113–119, vol. 1355.

Schulze, H.J., "The Telemetric Emergency Electrocardiography—Practical Use and Methodologic Effectiveness", periodical—Z Gesamete Inn Med, Dec. 15, 1986, pp 685–689, vol. 41 part 24.

Jones, J.W., "Remote Monitoring of Free Flaps with Telephonic Transmission of Photoplethysmograph Waveforms", periodical—Journal of Reconstructive Microsurgery, Apr. 1989, pp 141–144, vol. 5 part 2.

Bashein, G., "Anesthesia and Remote Monitoring for Intra-operative Radiation Therapy", periodical—Anesthesiology, Jun. 1986, pp 804–807, vol. 64 part 6.

Athan, Stephan, "Benefits of Spread Spectrum Technology in Present and Future Health Care Applications", conference—15<sup>th</sup> Annual International Conference IEEE Eng in Med & bio Soc, San Diego, CA, 1993, pp 1045–1046, vol. 15 part 2.

Hanley, J., "Telemetry in Health Care", periodical—Biomedical Engineering, Aug. 1976, pp 269–272, vol. 11 part 8.

\* cited by examiner

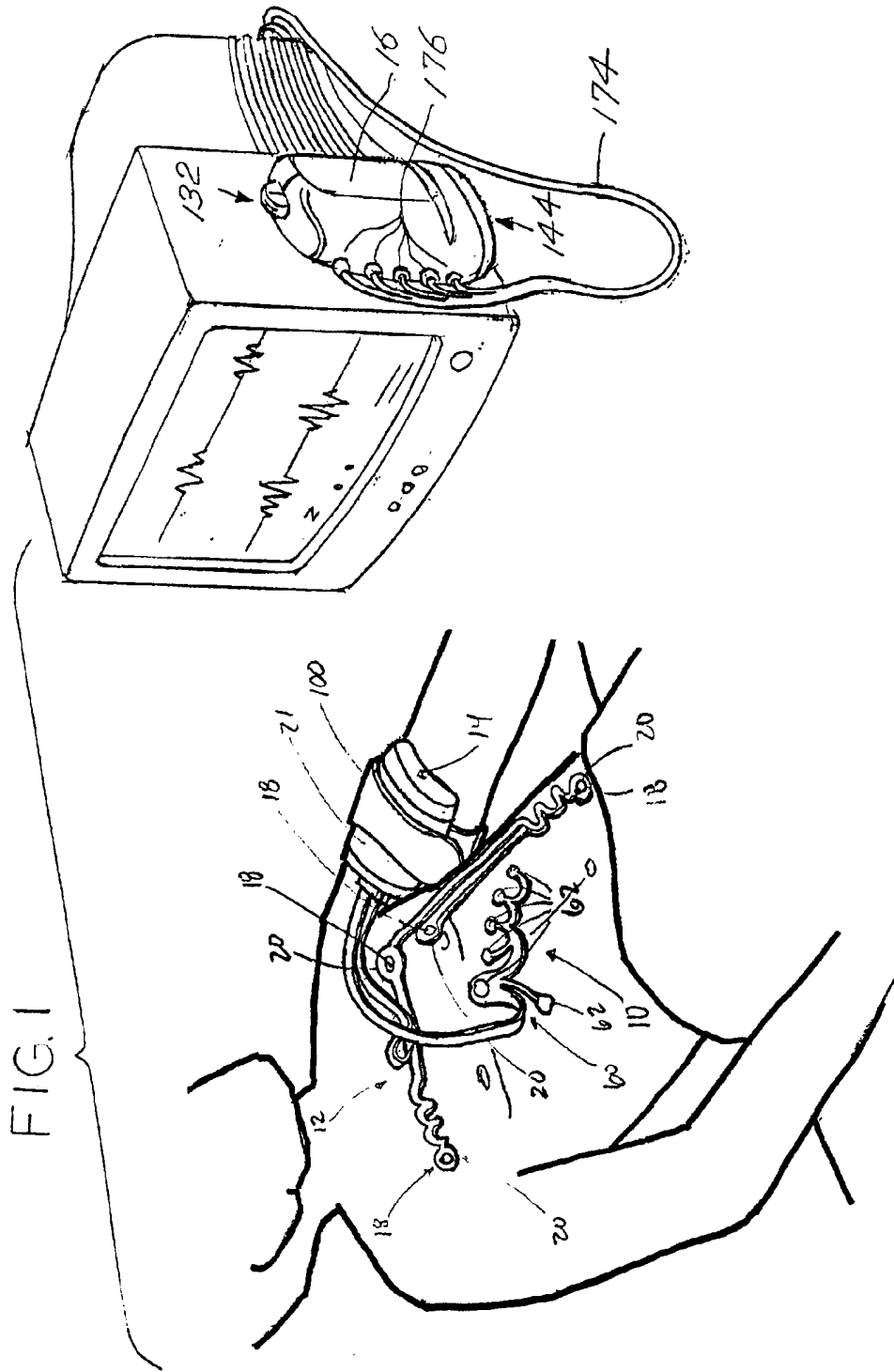

FIG. 2

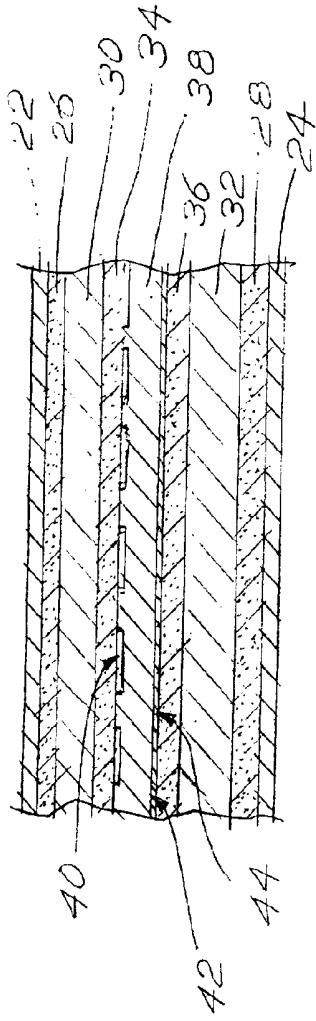
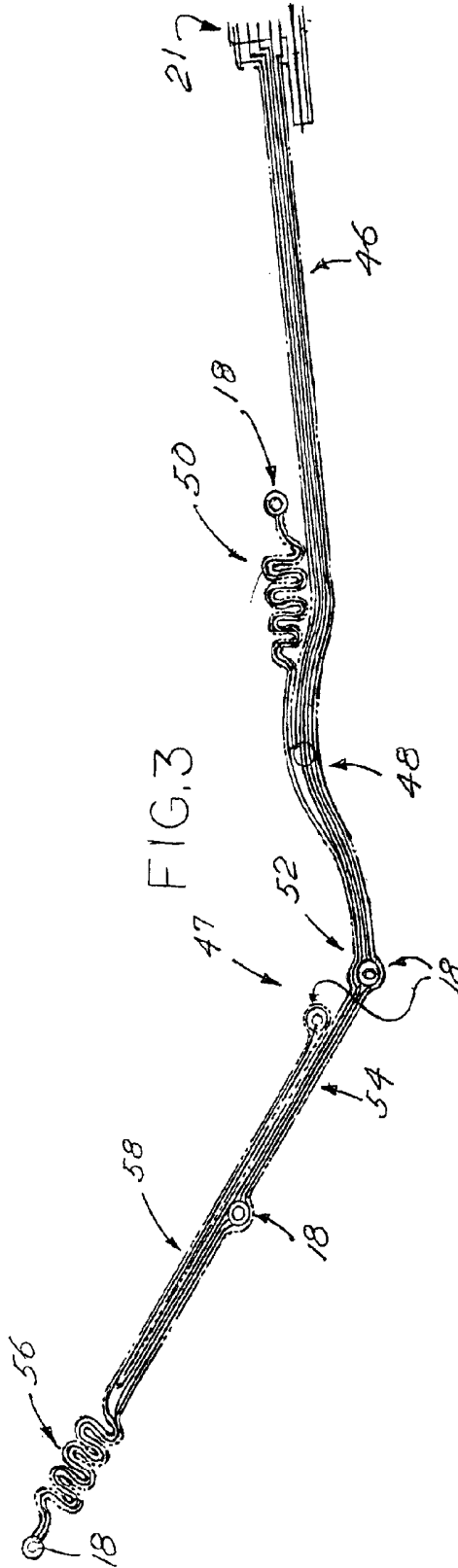

FIG. 3



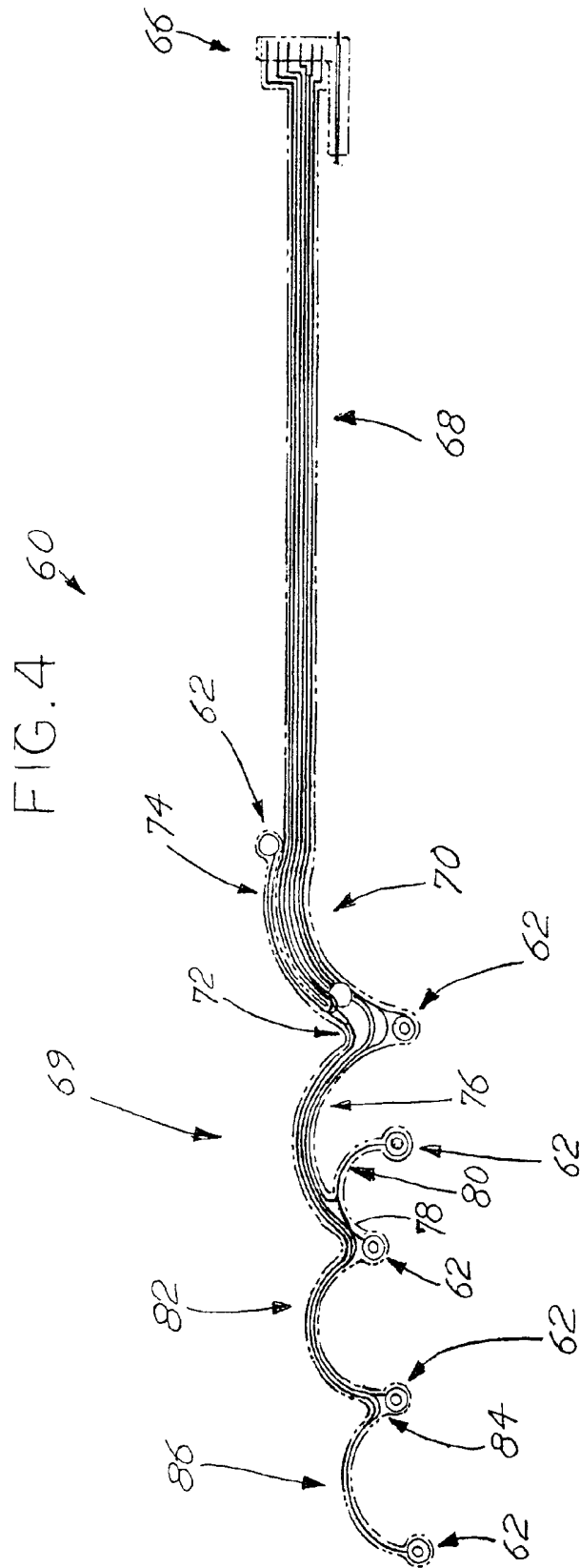

FIG. 5

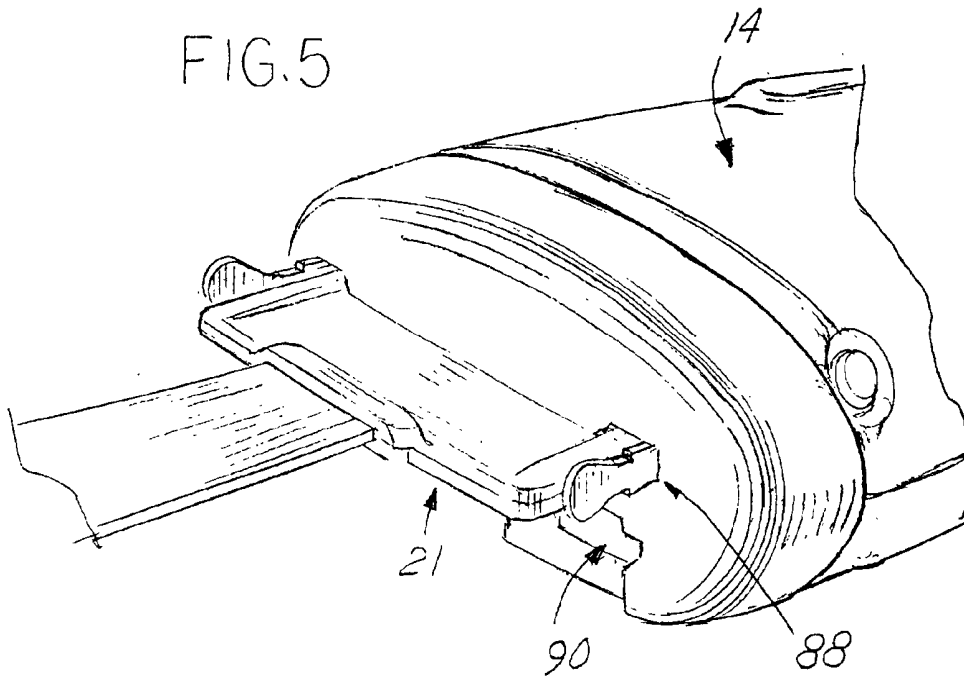
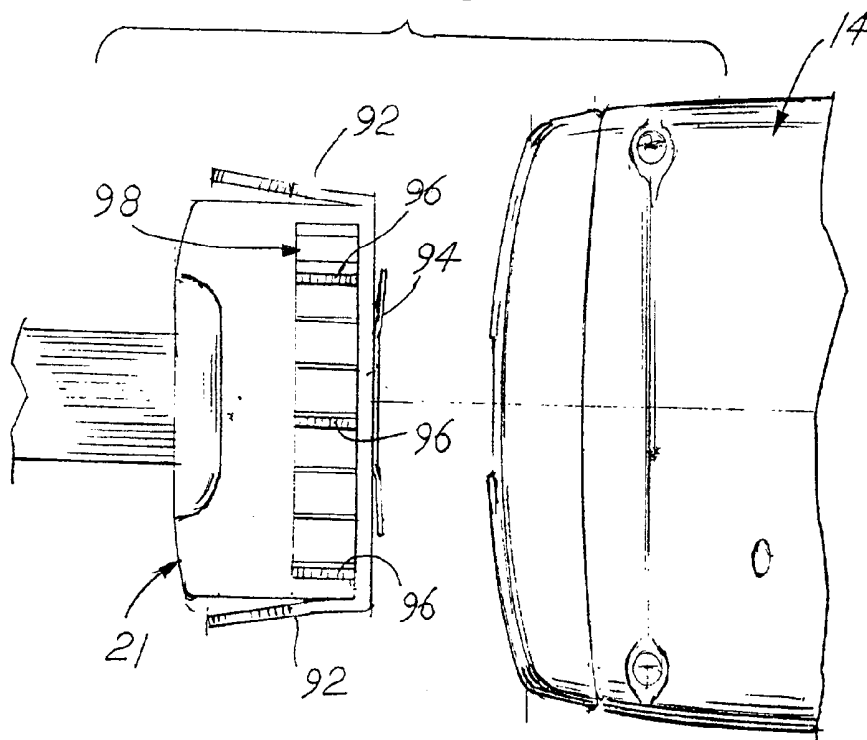

FIG. 6



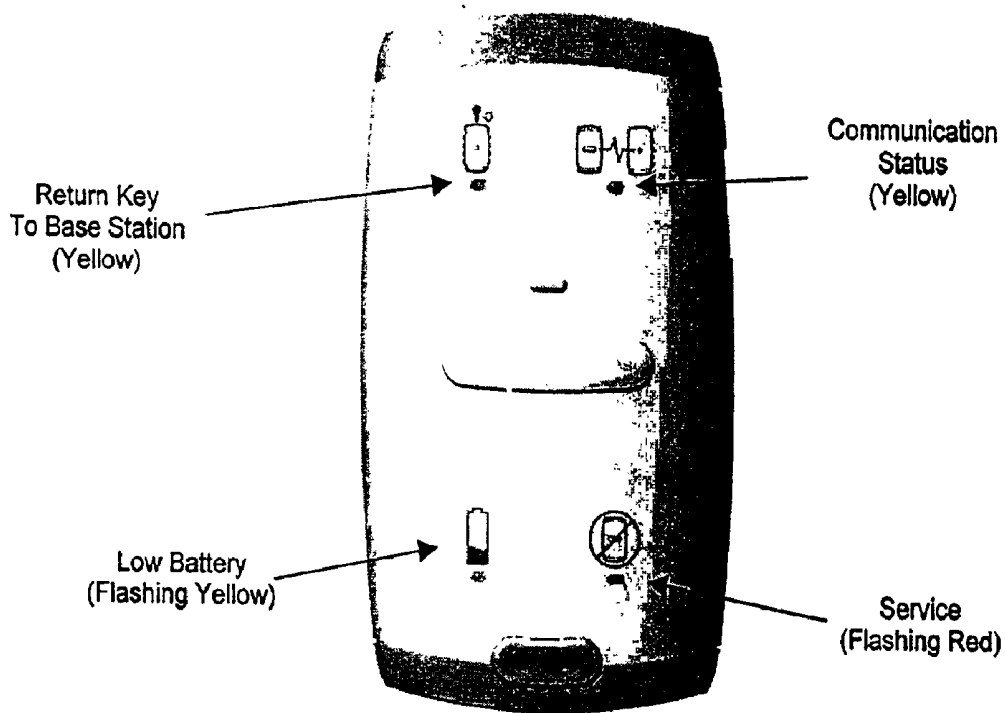
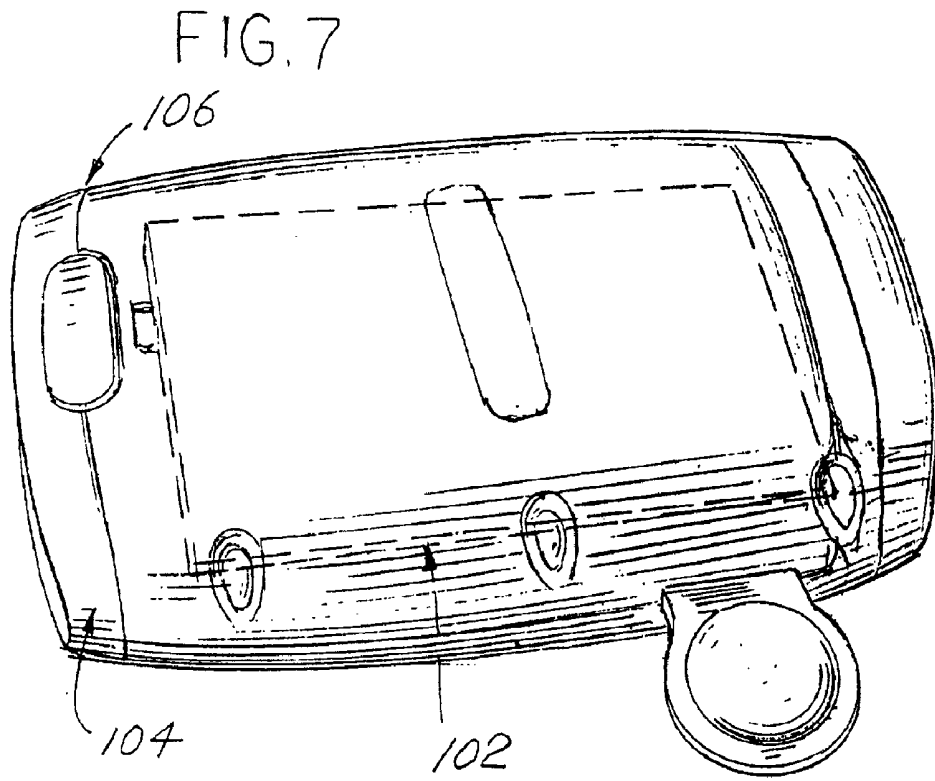
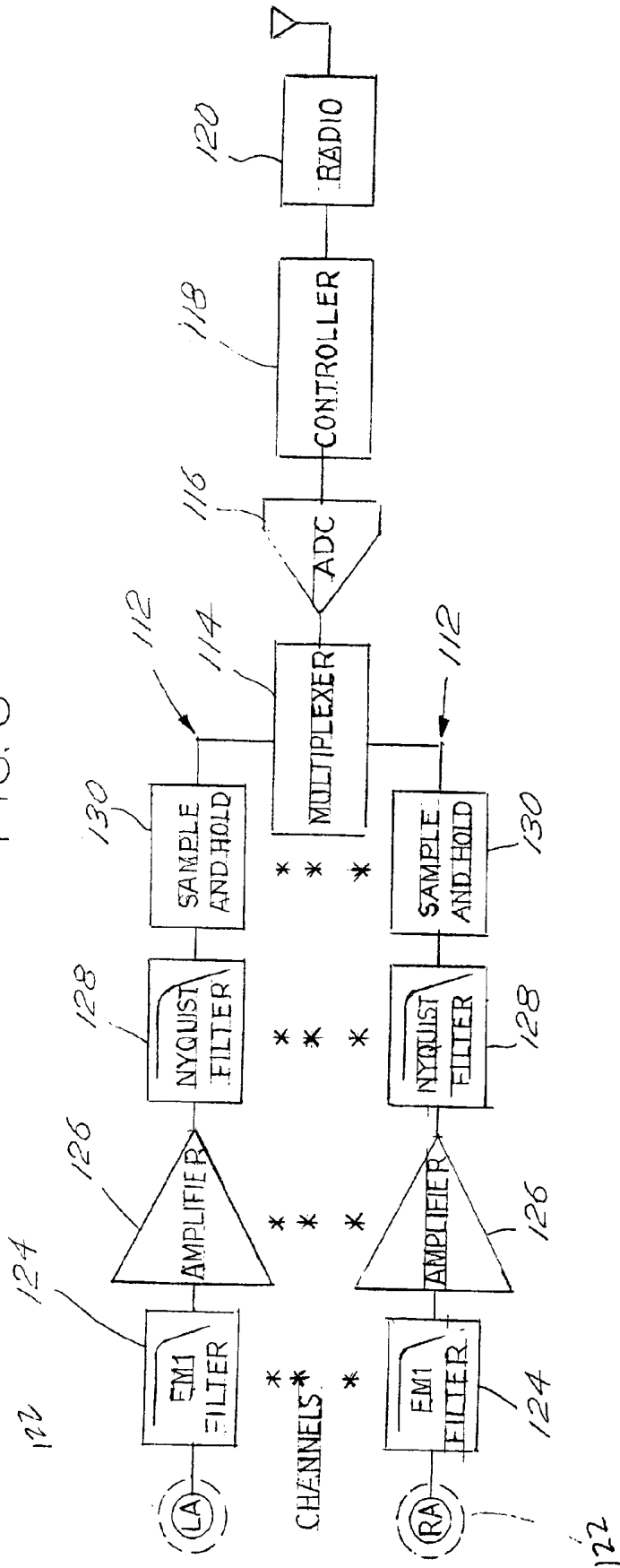

FIG. 7A

FIG. 8



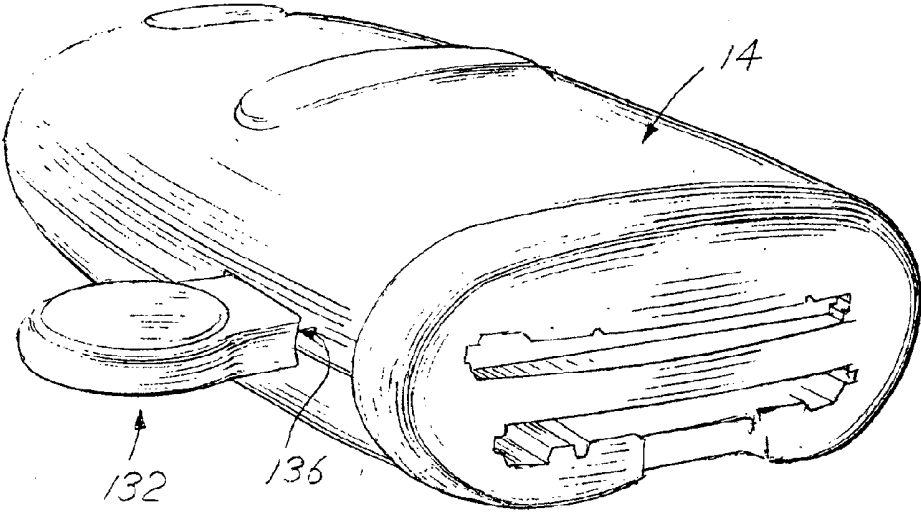
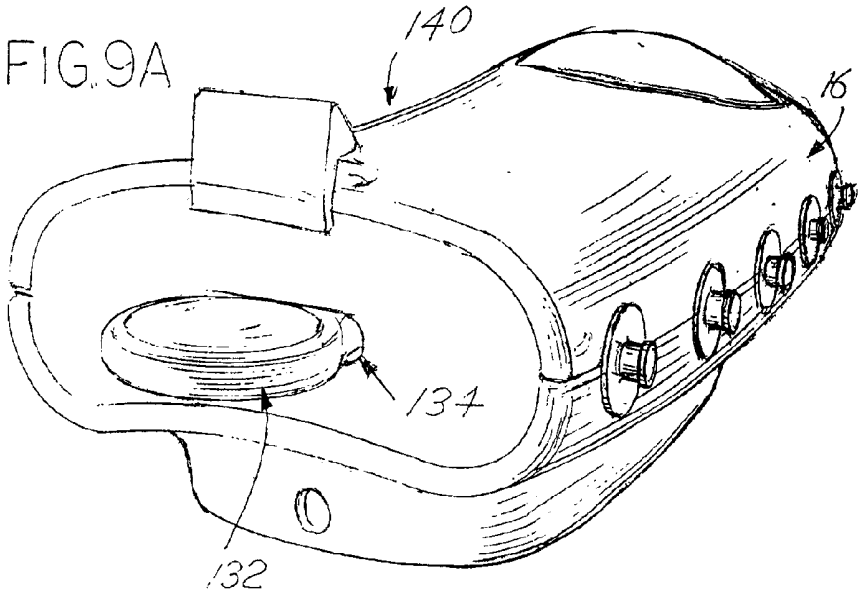

FIG. 9B

FIG. 10

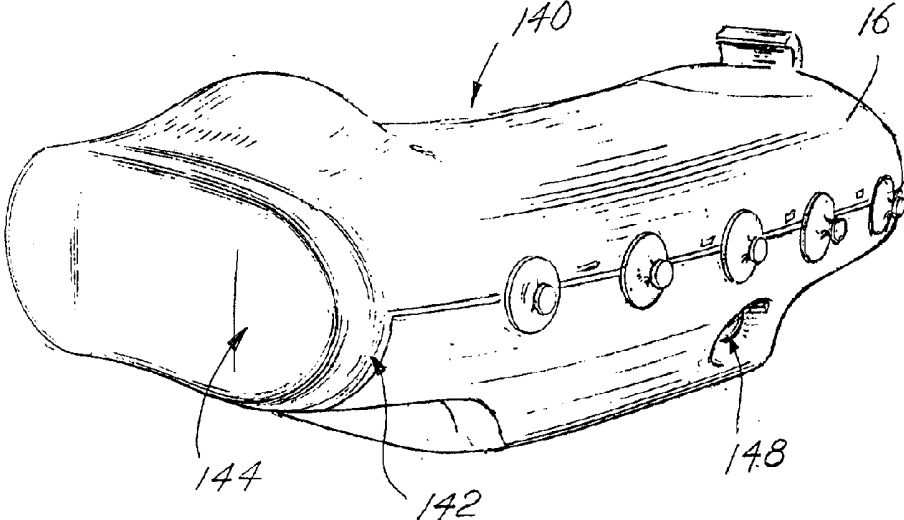
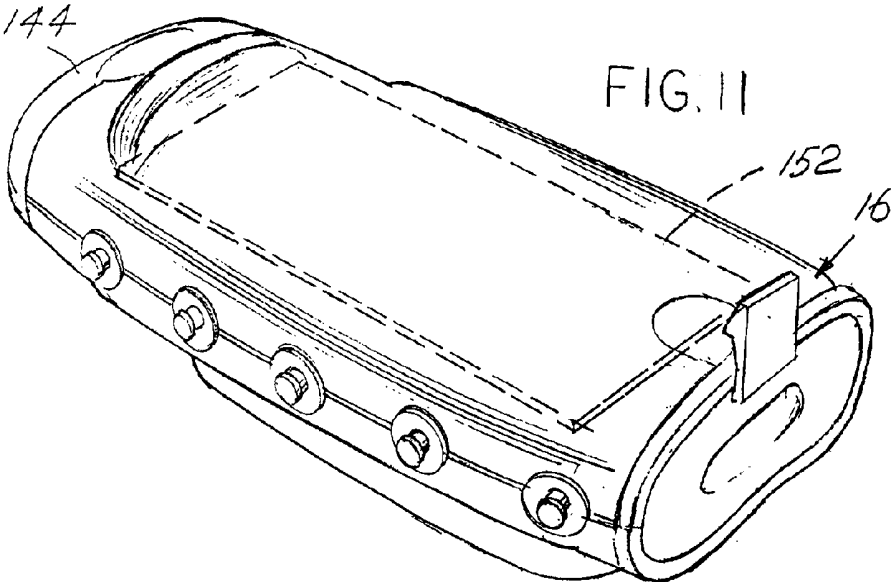

FIG. 11



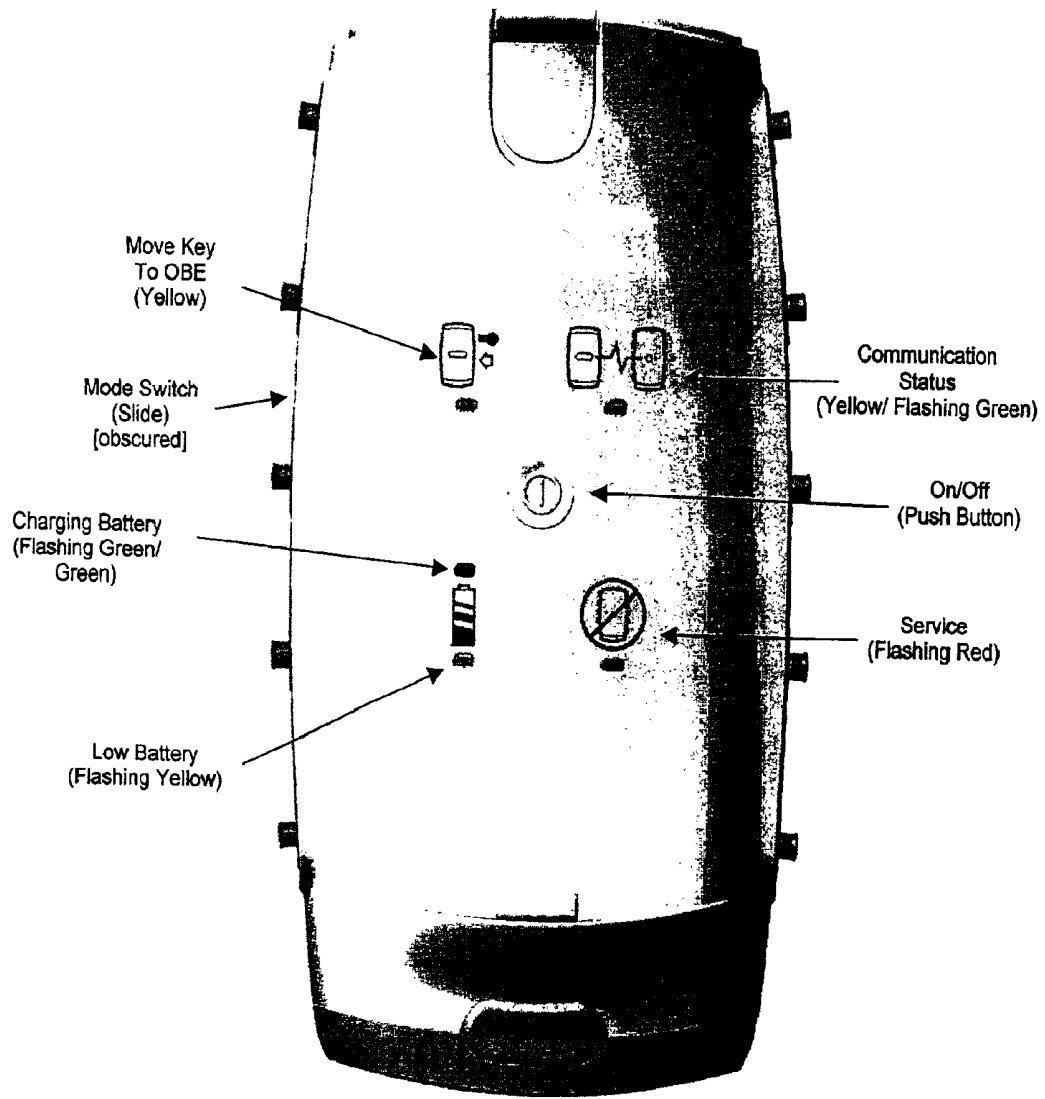
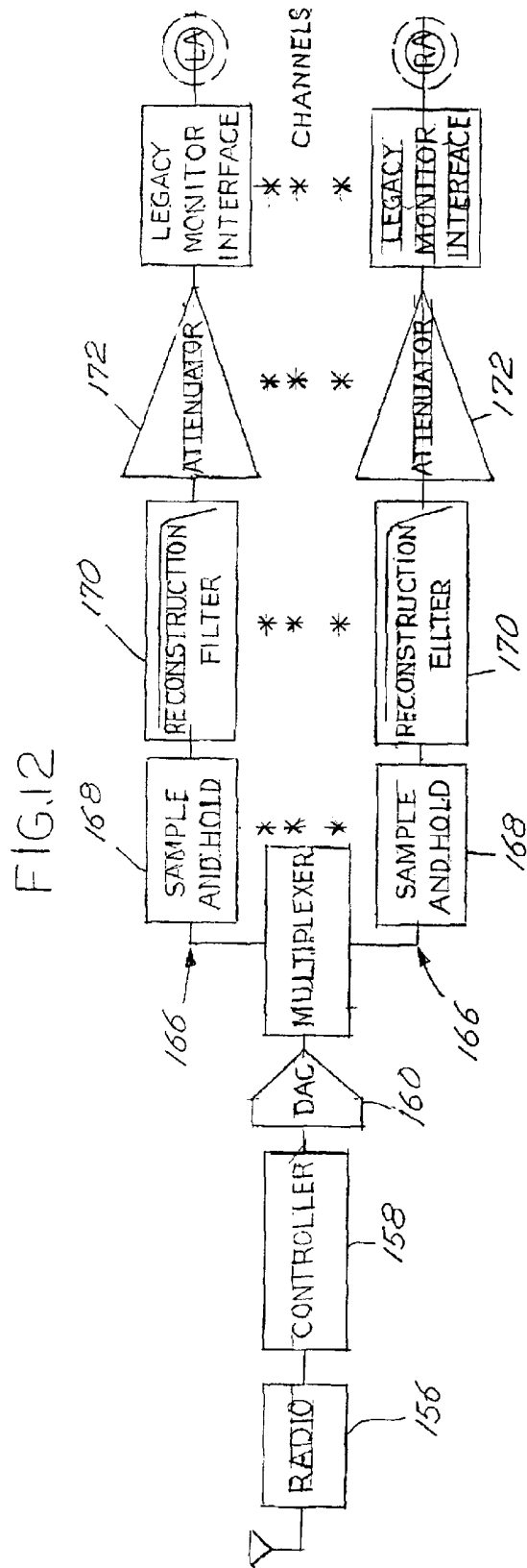

FIG. 11A.





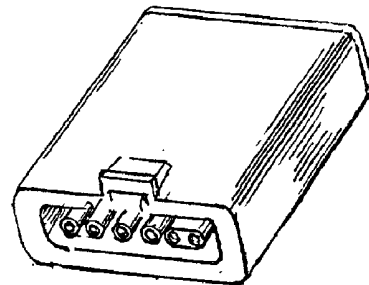
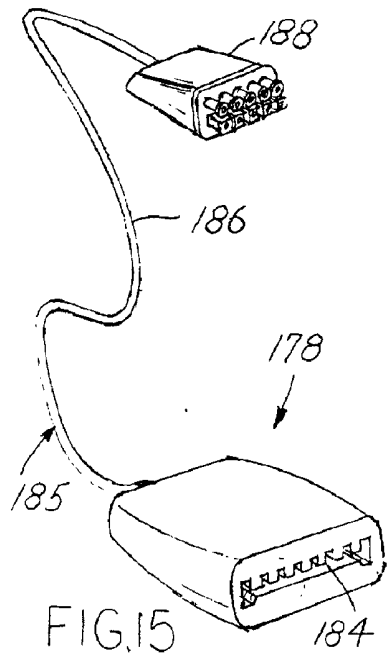
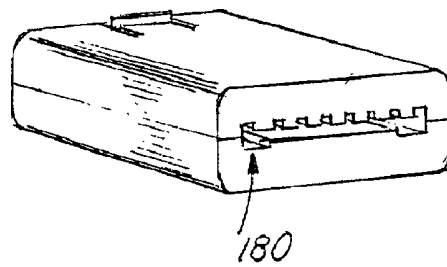

FIG. 14



180

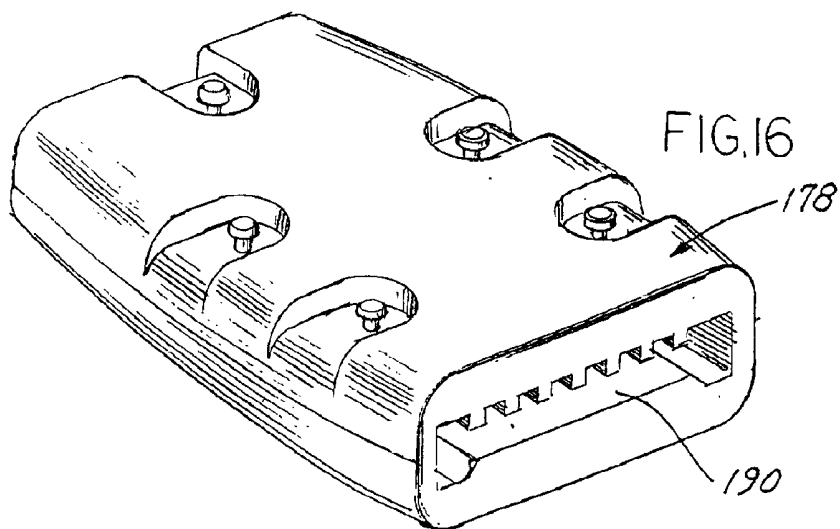
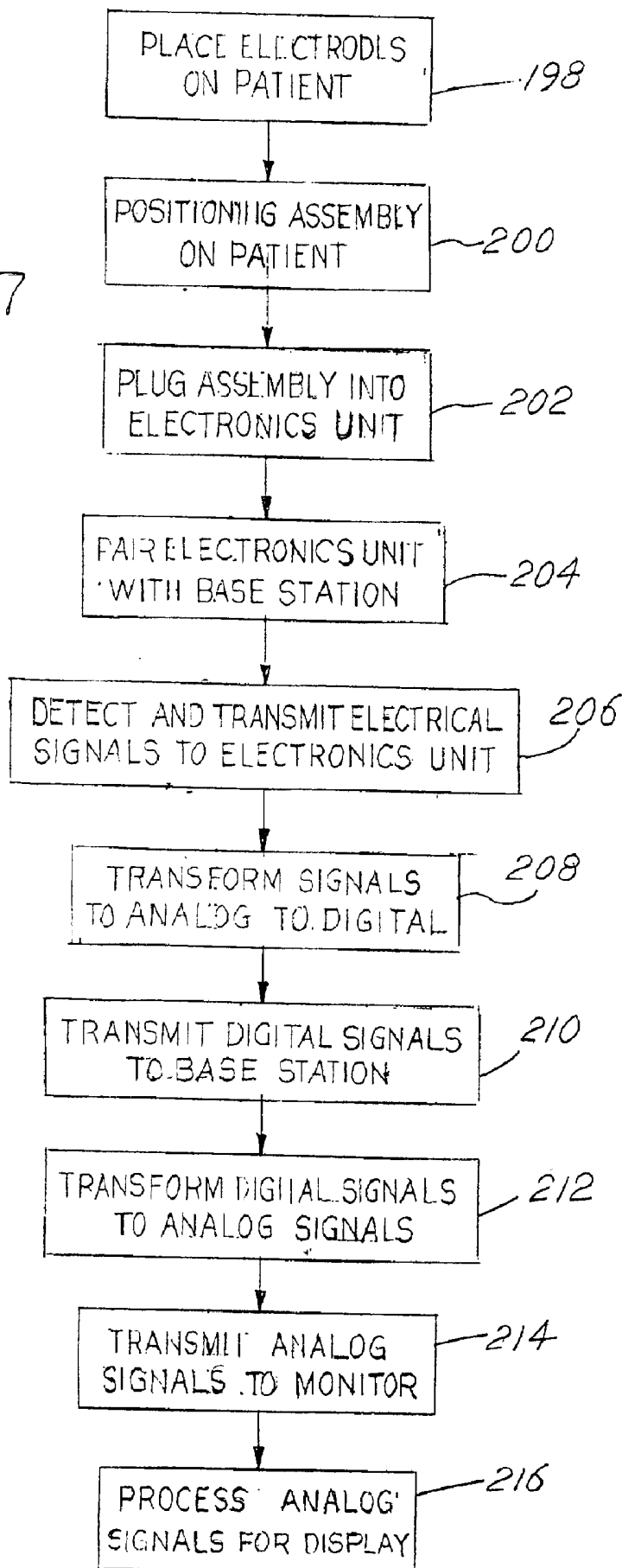

FIG. 16

190

FIG. 17



**WIRELESS ECG SYSTEM**

## RELATED APPLICATIONS

This application is a continuation-in-part and claims the benefit of the filing date pursuant to 35 U.S.C. §120 application Ser. No. 09/908,509, for a WIRELESS ELECTROCARDIOGRAPH SYSTEM AND METHOD, filed Jul. 17, 2001 now U.S. Pat. No. 6,611,705, the disclosure and content of which is hereby incorporated by reference in its entirety.

A portion of the disclosure of this patent document contains material that is subject to copyright protection. The copyright owner has no objection to the facsimile reproduction by anyone of the patent document or the patent disclosure, as it appears in the Patent and Trademark Office patent file or records, but otherwise reserves all copyright rights whatsoever.

## FIELD OF THE INVENTION

The present invention relates to a cardiac monitoring system and, more particularly, to a wireless electrocardiograph (ECG) system.

## BACKGROUND OF THE INVENTION

An electrocardiograph (ECG) system monitors heart electrical activity in a patient. Conventional ECG systems utilize conductive pads or electrodes placed on a patient in specific locations to detect electrical impulses generated by the heart during each beat. In response to detection of the electrical impulses from the heart, the electrodes produce electrical signals indicative of the heart activity. Typically, these electrical signals are directly transferred from the electrodes to a stationary ECG monitor via multiple cables or wires. The ECG monitor performs various signal processing and computational operations to convert the raw electrical signals into meaningful information that can be displayed on a monitor or printed out for review by a physician.

Doctors have used ECG systems to monitor a patient's heart activity for decades. Currently, there are several different systems that use ECG signals to monitor a patient's heart activity. These systems, however, are generally stationary and are not developed or suitable for portable use. While portable telemetry systems exist, they are not a direct replacement for stationary ECG monitors. Moreover, because conventional systems use multiple cables or wires, and are cumbersome and uncomfortable for the patient, and require a significant amount of set up time. Thus, a need exists for an ECG system that solves the aforementioned problems.

## BRIEF SUMMARY OF THE INVENTION

The present invention relates to a wireless ECG system that is universally compatible with existing or conventional ECG monitors. The ECG system comprises a chest assembly, a body electronics unit, and a base station. The chest assembly connects to electrodes specifically located on a patient's body for detecting electrical signals from the patient's heart. The electrical signals are detected by the chest assembly—thus, providing up to a “7 lead” analysis of the heart. Alternatively, the chest assembly can be augmented with a precordial assembly that connects to electrodes specifically located on the patient's body—thus, providing a “12 lead” analysis of the heart.

The electrical signals are transmitted through the chest assembly and the precordial assembly to the body electron-

ics unit, which removably secures to the patient via an armband. The body electronics unit transmits the electrical signals to the base station via radio transmission. The base station transmits the electrical signals to a conventional ECG monitor via standard cabling, which, in turn, processes or transforms the electrical signals into meaningful information that can be displayed on the ECG monitor for review by a physician.

The ECG system eliminates the wires that ordinarily tethers an ECG patient to an ECG monitor by replacing conventional wires with a radio link. The present invention is lightweight and portable—thereby providing increased comfort and mobility to the patient. In addition, the present invention requires decreased setup times and is more convenient for health practitioners to use than conventional ECG systems.

These as well as other novel advantages, details, embodiments, features, and objects of the present invention will be apparent to those skilled in the art from the following detailed description of the invention, the attached claims and accompanying drawings, listed herein below which are useful in explaining the invention.

## BRIEF DESCRIPTION OF THE DRAWING

The foregoing aspects and many of the advantages of the present invention will become readily appreciated by reference to the following detailed description of the preferred embodiment, when taken in conjunction with the accompanying drawings, wherein:

FIG. 1 is a perspective view of an exemplary embodiment of the ECG system;

FIG. 2 is a cross sectional view of the chest assembly and the precordial assembly;

FIG. 3 is a top view of an exemplary embodiment of the chest assembly;

FIG. 4 is a top view of an exemplary embodiment of the precordial assembly;

FIG. 5 is a perspective view of an exemplary embodiment of the body electronics unit;

FIG. 6 is a top view an exemplary embodiment of the assembly connectors;

FIG. 7 is a front view of an exemplary embodiment of the body electronics unit;

FIG. 7a is an exemplary embodiment of the user interface of the electronics body unit;

FIG. 8 is a block diagram of an exemplary embodiment of the transmitter;

FIG. 9a is a perspective view of an exemplary embodiment of the base station used in conjunction with the token key;

FIG. 9b depicts the body electronics unit used in conjunction with the token key;

FIG. 10 is a perspective view of an exemplary embodiment of the base station;

FIG. 11 is a front view of an exemplary embodiment of the base station;

FIG. 11a is an exemplary embodiment of the user interface of the base station;

FIG. 12 is a block diagram of an exemplary embodiment of the receiver;

FIG. 13 is a perspective view of an exemplary embodiment of the base station;

FIG. 14 is an exemplary embodiment of the adaptor assembly;

FIG. 15 is another exemplary embodiment of the adaptor assembly;

FIG. 16 is another exemplary embodiment of the adaptor assembly; and

FIG. 17 is a flow chart of an exemplary embodiment for operation of the ECG system.

#### DESCRIPTION OF THE PREFERRED EMBODIMENT

For a better understanding of the present invention, reference may be had to the following detailed description taken in conjunction with the appended claims and accompanying drawings. Briefly, the present invention relates to a wireless, portable ECG system. Referring to FIG. 1, the ECG system 10 comprises a chest assembly 12, a body electronics unit 14, and a base station 16.

The chest assembly 12 is a one-piece flexible circuit that connects a plurality of electrode connectors 18, which are individually labeled 18a, 18b, 18c, 18d, and 18e. The electrode connectors 18 have releasable connections that connect to electrodes 20, which are individually labeled 20a, 20b, 20c, 20d, and 20e. Preferably, the electrode connectors 18 have snap terminals that connect to electrodes 20 having snap terminals. Each electrode connector 18 connects to an electrically conductive element or trace for transmitting electrical signals. The electrically conductive elements or traces run along the chest assembly 12 and connect to a chest assembly connector 21.

Referring to FIG. 2, the chest assembly 12 has outer layers 22, 24 that are constructed of a lightweight and reasonably moisture resistant material, such as DuPont Sontara® or other suitable fabric. Adhesive layers 26, 28 secure insulating layers 30, 32 to the outer layers 22, 24 respectively. Insulating layers 30, 32 are constructed of Mylar® (polyester) film or other suitable insulating material. Adhesive layers 34, 36 secure the insulating layers 30, 32 to a base layer 38. The base layer 38 is preferably constructed of Mylar film and has a first side 40 and a second side 42. The electrically conductive elements or traces that connect to the electrode connectors 18 are located on the first side 40 of the base layer 38. One such conductive element or trace is shown at 39. A shielding layer 44 for reducing any external interferences or radio frequency noise with the chest assembly 12 is located on the second side 42 of the base layer 38. The shielding layer 44 may be constructed of single or multiple layers of dielectric, or electrically or magnetically conductive material. The back of the electrode connector 18 may also be covered with Mylar to further insulate the chest assembly 12 and prevent an externally applied electric potential from entering the ECG system. The shielding layer preferably comprises an X-patterned grid (graphically represented with hash marks on shielding layer 44 in FIG. 2.)

Referring back to FIG. 1, the chest assembly 12 attaches to five electrodes 20 and provides a means for generally positioning the electrodes on the patient, thereby providing up to a "7 lead" analysis of the electrical activity of the heart. The electrode connectors 18 are preferably labeled and color-coded to ensure that the chest assembly 12 is properly positioned on the patient and connected to the appropriate electrodes 20. For instance, the electrode connectors 18a, 18b, 18c, 18d, 18e are labeled RL, LA, LL, RA, and V, respectively. The chest assembly 12 is constructed such that the RA electrode connector is connected to an electrode positioned on the right side of the patient's chest about level of the first and second intercostal space, the LA electrode connector is connected to an electrode positioned on the left

side of the patient's chest about level of the first and second intercostal space, the RL and LL electrode connectors are connected to electrodes positioned on the left side of the patient's torso, and the V electrode connector is connected to an electrode positioned in the middle of the patient's chest about level of the fourth and fifth intercostal space. The chest assembly 12 is designed such that it is centered on the chest below the patient's clavicle.

Referring to FIG. 3, the chest assembly 12 is configured to provide flexible positioning of the chest assembly 12 on the patient. FIG. 3 is for illustrative purposes only, and thus, the chest assembly 12, as depicted in FIG. 3, is not limited to any particular shape or configuration. The chest assembly 12 has a linear section or tail 46 extending from the chest assembly connector 21. Referring back to FIG. 1, the tail 46 has a securing means 46a which allows the tail 46 to extend to either side of the patient. This securing means 46a may be any suitable mechanical device although adhesive or a clip is most preferred. Referring back to FIG. 3, the tail 46 flows into an electrode retaining section 47. The electrode retaining section 47 has an arcuate section 48. A first expandable arm 50 attaches to the arcuate section 48. The RA electrode connector attaches to the first expandable arm 50. The arcuate section 48 flows into a transition section 52. The LA electrode connector attaches to the transition section 52. The transition section 52 flows into a linear run 54. The RL electrode connector attaches to the linear run 54. A second expandable arm 56 and an extension arm 58 attach to the linear run 54. The V electrode connector attaches to the second extension arm 58 and the LL electrode connector attaches to the second expandable arm 56.

The expandable arms 50, 56 are die cut in a serpentine pattern. The expandable arms 50, 56 comprise polypropylene or polyethylene fabric, Kapton, Mylar, or other flexible, memoryless material. The expandable arms 50, 56 expand, if necessary, by elongating the serpentine pattern. When expanded, a portion or all of the expandable arm is extended. Where only a portion of the expandable arm is extended, another portion remains folded. The expandable arms 50, 56 allow for extension as needed to so that the chest assembly 12 can fit patients of various sizes and also allow for patient movement when the patient is wearing the chest assembly 12. The extension arm 58 allows for flexible positioning of the V electrode connector in the middle of the patient's chest such as placement at electrode position V1, V2 or V3. In some instances, the health care practitioner may desire not to utilize the extension arm 58 for taking electrocardiograph measurements. Thus, to keep the extension arm 58 secured to the linear run 58 and to ensure that the extension arm 58 will not interfere with the placement and positioning of the chest assembly 12, the extension arm 58 is die cut with a perforated seam that connects the extension arm 58 and the linear run 54 along the length of the extension arm 58. If the health care practitioner desires to use the extension arm 58, the perforated seam is unbroken so that the extension arm 58 can be selectively positioned on the patient's chest.

The chest assembly 12 can be used with a precordial assembly 60 to provide a "12-lead" analysis of the electrical activity of the heart. Similar to the chest assembly 12, the precordial assembly 60 is a one-piece flexible circuit that connects a plurality of electrode connectors 62. The electrode connectors 62 have releasable connections that connect to electrodes 64. Preferably, the electrode connectors 62 have snap terminals that connect to electrodes 64 having snap terminals. Each electrode connector 62 connects to an electrically conductive element or trace for transmitting electrical signals from a patient's heart. The electrically

conductive elements or traces run along the precordial assembly 60 and connect to a precordial assembly connector 66. The precordial assembly 60 has the construction as shown in FIG. 2.

As depicted in FIG. 1, the precordial assembly 60 attaches to six electrodes 64 that are selectively positioned on the abdomen and middle chest of the patient. The electrode connectors 62 of the precordial assembly 60 are preferably labeled and color-coded so as to prevent a health care provider from applying or positioning the precordial assembly onto the patient improperly. For instance, the electrode connectors 62a, 62b, 62c, 62d, 62e, and 62f are labeled V1, V2, V3, V4, V5, and V6 respectively. When the precordial assembly 60 is used, the V electrode connector on the chest assembly 12 is removed from its electrode and replaced with an electrode connector on the precordial assembly 60.

As shown in FIG. 4, the precordial assembly 60 is configured to provide flexible positioning of the precordial assembly 60 on the patient. FIG. 4 is for illustrative purposes only, and thus, the precordial assembly 60, as depicted in FIG. 4, is not limited to any particular shape or configuration. The precordial assembly has a linear section or tail 68 extending from the precordial assembly connector 66. The linear section or tail 68 flows into an electrode retaining section 69. The electrode retaining section 69 has a first arcuate section 70 having a first transition section 72. The V2 electrode connector attaches to the first transition section 72. The V1 electrode connector attaches to a first extension arm 74 connected to the first transition section 72. A second arcuate section 76 extends from the first transition section 72. A second transition section 78 abuts the second arcuate section 76 and the V4 electrode connector attaches to the second transition section 76. The V3 electrode connector attaches to a second extension arm 80 connected to the second transition section 78. A third arcuate section 82 flows from the second transition section 78. The third arcuate section 82 abuts a third transition section 84. The V5 electrode connector attaches to the third transition section 84. A fourth arcuate section 86 extends from the third transition section 84. The V6 electrode attaches to the fourth arcuate section 86. The configuration of the precordial assembly 60 allows the health care provider or physician to flexibly position the electrode connectors 62 as needed to properly situate the precordial assembly 60 on the patient and to allow for patient movement when the patient is wearing the precordial assembly 60.

In operation, the chest assembly 12 and the precordial assembly 60 detect electrical signals generated by the heart during each beat and transfer these signals to the body electronics unit 14. When the system is operating in “7 lead” mode (i.e. when only the chest assembly 12 is being used) the body electronics unit 14 acquires signals from the RL, RA, LL, LA, and V electrodes. The body electronics unit 14 uses the RL electrode as a ground reference. When the system is operating in the “12 lead” mode (i.e. the chest assembly 12 and the precordial assembly 60 are being used) the body electronics unit 14 acquires signals from the RL, RA, LL, and LA electrodes via the chest assembly 12 and acquires signals from the V1, V2, V3, V4, V5, and V6 electrodes via the precordial assembly 60. Alternatively, a various number of electrodes may be monitored by the system. For example, the health care provider or physician may choose to use only two electrodes to monitor the heart, seven electrodes to monitor the heart, or the like. In other words, the present system is not limited to performing a “7 lead” and “12 lead” analysis of the heart. In addition, to detecting electrical signals from the heart, the chest assem-

bly 12 and the precordial assembly 60 may be constructed to detect other vital signs of the patient, for example, pulse, respiration rate, heart rate, temperature EEG signals, and pulse oximeter signals.

Referring to FIG. 5, the chest assembly 12 connects to the body electronics unit 14 via a chest assembly connector 21. Specifically, the chest assembly connector 21 inserts into a chest assembly port 88 located in the body electronics unit 14. Similarly, the precordial assembly 60 connects to the body electronics unit 14 via the precordial assembly connector 66. Specifically, the precordial assembly connector 66 (not shown) inserts into a precordial assembly port 90. Resistors are connected to the chest assembly port 88 and the precordial assembly port 90 to prevent excessive electrical current from entering the body electronics unit 14—thereby ensuring that the body electronics unit 14 continues to operate properly in the presence a strong electrical current caused by a defibrillator (i.e. a 5 kV defibrillation excitation). The chest assembly connector 21 and the precordial assembly connector 66 are specifically keyed or configured to prevent the assembly connectors 21, 66 from being inserted into the assembly ports 88, 90 backwards, misaligned or otherwise improperly. Moreover, the chest assembly connector 21 is keyed or configured such that it is not compatible with the precordial assembly port 90. Likewise, the precordial assembly connector 66 is keyed or configured such that it is not compatible with the chest assembly port 88. Specifically, as shown in FIG. 5A, the chest assembly connector 21 has tongues 21a specifically configured or arranged to fit into corresponding grooves 21b of the chest assembly port 88. Accordingly, the chest assembly connector 21 can only be connected to the chest assembly port 88 in one orientation. For example, if the tongues 21a are not aligned with the grooves 21b, the chest assembly connector 21 will not couple to the chest assembly port 88. Likewise, the precordial assembly connector 66 has tongues (not shown) specifically configured or arranged to fit into corresponding grooves (not shown) of the precordial assembly port 90.

As shown in FIG. 6, the chest assembly connector 21 and the precordial assembly connector 66 (not shown) have retaining clips or flanges 92 located on the sides of the connectors 21, 66 for removably securing the connectors 21, 66 into the assembly ports 88, 90. However, other means may be used to removably secure the connectors 21, 66 in the assembly ports 88, 90, such as screws, pins or the like. In addition, the assembly connectors 21, 66 may have spring flanges or clips 94 located at the tip of the connectors 21, 66 for providing a bias or tension against the assembly ports 88, 90. The spring flanges or clips 94 provide the connectors 21, 66 with a secure fit within the assembly ports 88, 90, thereby reducing any play or movement of the connectors 21, 66 within the assembly ports 88, 90. The electrically conductive elements or traces are specifically configured on the connectors 21, 66 so as to ensure that the electrical signals from the heart are properly transmitted to the body electronics unit 14. In other words, the electrically conductive elements or traces must be sufficiently spaced apart or otherwise isolated in some manner to prevent arcing across the electrically conductive elements. In addition, the spacing of the electrically conductive elements or traces permits the chest assembly and the precordial assembly to withstand defibrillation shock. Furthermore, the connectors 21, 66 have ribs 96 for preventing the electrically conductive elements or traces from coming into contact with metal objects or the like when the connectors 21, 66 are not inserted into the assembly ports 88, 90.

The chest assembly connector **21** has a sensor pin or ground pin **98** that completes a circuit within the body electronics unit **14** when the chest assembly connector **21** is plugged into the chest assembly port **88**, thereby activating the power and bringing the body electronic unit **14** out of “sleep mode.” The sensor pin has specific tongue that corresponds and fits into a groove located in the chest assembly port **88**. The sensor pin **98** serves as a means for the body electronics unit **14** to identify the chest assembly **12** and to prevent the use of other chest assemblies or electrocardiograph wearables that are not designed to be used with the on-body electronic unit **14**. In other words, the power of the body electronics unit **14** will not activate unless the body electronics unit **14** identifies or recognizes the sensor pin **98** of the chest assembly **12**.

The outside casing of the body electronics unit **14** is constructed of lightweight, molded plastic, such as acrylonitrile-butadiene-styrene (ABS) or other suitable material. The shape and configuration of the body electronics **14** unit is not limited to any particular shape or configuration. As shown FIG. **1**, the body electronic unit **14** removably secures to the patient’s arm via an armband **100**, thus making the body electronics unit **14** readily accessible to the patient. The armband **100** wraps around either the patient’s right or left arm and attaches via Velcro or other suitable fastening means such as pins, snaps, or the like. The body electronics unit **14** slides under a strap or pocket on the armband **100**. Referring to FIG. **7**, the body electronic unit **14** has a user interface **102** and a battery **104**. The user interface **102** provides information to the patient pertaining to the system’s operating status or functionality. For example, an exemplary embodiment of the user interface **102** may provide information on whether the body electronics unit **14** is communicating or transmitting normally to the base station **16**, whether the battery **104** of the body electronics unit **14** is charging or the battery **104** is low, whether the power of the body electronics unit **12** is activated, or whether the body electronics unit **14** or base station is malfunctioning. In addition the user interface **102** may provide instructions on the correct order or procedure for pairing or coupling the body electronics unit **14** with the base station **16**. Such information may be communicated to the patient via the user interface **102** in various ways, for example, LEDs, LCD, text, audible tones, etc. An exemplary embodiment of the user interface is shown in FIG. **7a**. The user interface **102** is readily accessible to the patient when the body electronics unit **14** is secured to the armband **100**.

The battery **104** is inserted into a battery port **106** located in the bottom of the body electronics unit **14**. The battery **104** is retained in the battery port **106** by latches or other suitable fastening means, such as clips, screws or the like. The battery **104** is preferably a 3.6 V Li-ion rechargeable battery. The battery **104** is readily accessible to the patient when the body electronics unit **14** is secured to the armband **100**.

The body electronics unit **14** controls the acquisition of the ECG signals from the chest assembly **12** and the precordial assembly **60**. A transmitter **108** within the body electronics unit **14** receives or acquires ECG signals from the chest assembly **12** and the precordial assembly **60** preferably at 3 kbps. When the system is operating in “7 lead” mode (i.e. when only the chest assembly **12** is being used) the body electronics unit **14** acquires signals from the RL, RA, LL, LA, and V electrodes. When the system is operating in the “12 lead mode” (i.e. the chest assembly **12** and the precordial assembly **60** are being used) the body electronics unit **14** acquires signals from the RL, RA, LL,

and LA electrodes via the chest assembly **12** and acquires signals from the V1 thru V6 electrodes via the precordial assembly **60**. In addition, other vital signs of the patient may be detected by the system and transmitted to the body electronics unit **14**, for example pulse, respiration rate, heart rate, temperature, EEG signals and pulse oximeter signals.

As shown in FIG. **8**, the transmitter **108** comprises an application specific integrated circuit, a processor or other circuit **110**, a plurality of signal channels **112**, a multiplexer **114**, an analog-to digital converter (ADC) **116**, a controller **118**, and a radio **120**. Additionally, fewer or different components can be used. The body electronics unit **14** has nine signal channels **112** corresponding to the ten electrodes connected to the chest assembly **12** and the precordial assembly **60**. The electrode channels **112** each comprise a connector **122**, a filter **124**, an amplifier **126**, a Nyquist filter **128** and a track and hold circuit **130**. The connectors **122** of the signal channels **112** connect to either the chest assembly port **88** or the precordial assembly port **90**, depending on whether the electrode channel **112** corresponds to an electrode located on the chest assembly **12** or the precordial assembly **60**. The filter **124** comprises a low pass filter, such as for removing electromagnetic interference signals. The amplifier **126** amplifies the signals from the electrodes. The Nyquist filter **128** comprises a low pass filter for removing out-of-band high frequency content of the amplified signals to avoid sampling error. The track and hold circuit **130** enables the system to sample all nine electrode channels signals **112** at a same or relative times so that there is not differential error created when these signals are combined later in an ECG monitor.

The multiplexer **114** sequentially selects signals from the electrode signal channels **112** using time division multiplexing. One of ordinary skill in the art, however, recognizes that other combination functions can be used. The ADC **116** converts the combined analog signals to digital signals for transmission. Preferably the controller **118** comprises a digital signal processor (DSP) that decimates the digitized signals as to lessen the bandwidth required to transmit the signals. The radio **120** modulates the digital signals with a carrier signal for transmission. In an exemplary embodiment, the radio **120** includes a demodulator for receiving information. The controller **118** digitally transmits the ECG data to the base station **16**. In addition to transmitting ECG data, the controller **118** may transmit signals pertaining to pacemaker information, battery level information, electrode disconnection information, and other information as required. For example, vital signs such as pulse, respiration rate, heart rate, temperature, EEG signals, and pulse oximeter signals may be transmitted.

The body electronics unit continuously monitors the integrity of all patient electrode connections. In the event a lead is disconnected, the body electronics unit will send a signal to the base station which in turn causes the base station to trigger the “lead off” alarm on the ECG monitor. Additionally, the body electronics unit has a self-test function which monitors the integrity of the primary functions including the microprocessor, data acquisition, internal voltage references, and radio functionality. In the event a failure is detected, the body electronics unit will capture the fault condition, stop data acquisition and transmission and indicate that fault has occurred through the lead off alarm.

The body electronics unit **14** operates to minimize undesired noise or signals. For example, components are matched such that later application to a differential amplifier in a legacy ECG monitor for determining a heart vector is accurate. ECG vectors are not formed by the ECG system

10, but rather by the legacy ECG monitor. Because the ECG system 10 is essentially “in-series” with the legacy ECG monitor, any error may produce undesirable results. One potential source of error is differential error. This differential error can be observed on the legacy ECG monitor when the ECG monitor forms the ECG lead signals by combining the individual electrode signals in the ECG monitor input stage. This input stage comprises a difference, or differential, amplifier to eliminate common mode interference from the signals produced at the electrodes 20.

An artifact will be present if there is any difference in how each of the electrode signals are processed when the legacy ECG’s differential amplifier forms the ECG lead signals or ECG vectors. For example, if there is a difference in the gain of the amplifier, a difference in the phase shift associated with the anti-aliasing (Nyquist) filters, or a difference in how the respective track and hold circuits treat the electrode signals, then this differential error creates an artifact on the legacy ECG monitor. One important technique to minimize this potential source of differential errors is to choose a Nyquist filter cutoff frequency that is very high. This is because each individual filter will have differing group delay performance. To mitigate that difference, the frequency that this group delay will affect is much higher than the frequency of the ECG signals, which are about 0.05 Hz to 150 Hz. By choosing a high cutoff frequency for the Nyquist filters, any mismatch in the Nyquist filter components will not affect accuracy of the individual electrode ECG signals. For example, picking a filter cutoff frequency of 1,200 Hz mitigates this source of error. With this approach, the individual electrode ECG signals are over sampled at about 3,000 Hz in order to not introduce aliasing. Of course higher filter cutoff frequencies and correspondingly higher sampling rates may further reduce error. Lower cutoff frequencies and/or sampling rate may be used.

Because the electrode signals are now sampled at such a high rate, these signals may be decimated to minimize the required transmission bandwidth. For example the digital samples are decimated by a factor of eight in the controller 118. Greater or lesser rates of decimation can be used, such as decimation as a function of the bandwidth available for transmission, the number of electrode signals to be represented, and the Nyquist sampling rate. Referring back to FIG. 1, the base station 16 receives the transmitted signals sent from the body electronics unit 14. The signals are transmitted as radio or other signals modulated with a carrier signal. Various air-interfaces can be used for transmission, such as Bluetooth or IEEE 802.11b. To establish proper communication between the body electronics unit 14 and the base station 16, the base station 16 and body electronics unit 14 need to be paired such that the base station 16 and the body electronics unit 14 only recognize signals from the its pair. This may be accomplished in number of ways including direct connection of the base station 16 and the body electronics unit 14. Preferably, a token key 132 is used to pair or radio frequency link the body electronics unit 14 and the base station 16. Referring to FIG. 9a, the token key 132 has memory chip and may optionally have a plurality of tongues or pins 133 that fit within grooves located in a token key port 134 of the base station 16 and within grooves of a token key port 136 of the body electronics unit 14. As shown in FIG. 9b, the token key 132 inserts into the token key port 134 of the base station and reads and records an identification number for the base station 16. The token key 132 is then removed from the token key port 134 and inserted into the token key port 136 located in the body electronics unit 14. The electronics unit 14 receives the identification num-

ber for the base station 16 from the token key 132. In turn, the token key 132 reads and records the identification number for the body electronics unit 14. The token key 132 is then removed from the body electronics unit 14 and reinserted into the token key port 134 of the base station 16 whereby the base station 16 confirms the presence of its own identification number on the token key 132 and also reads the identification number for the body electronics unit 14 from the token key 132. The body electronics unit 14 and the base station 16 are paired. Alternatively, pairing or coupling can be accomplished by first inserting the token key 132 into the body electronics unit 14, removing the token key 132 and inserting the token key 132 into the base station 16, removing the token key 132 and reinserting the token key 132 into the body electronics unit 14. In other words, the order in which the token key 132 is inserted into the body electronics unit 14 and the base station 16 is not critical to the proper operation of the system. Referring back to FIG. 7, the user interface 102 may provide the user or health care provider with instructions on the correct order for pairing the body electronics unit 14 with the base station 16. The use of the token key 132 allows the pairing function to occur while the body electronics unit 14 is worn by the patient. This feature eliminates the need to disconnect and reconnect the body electronics unit 14 when a patient needs to be connected to different ECG monitors as a result of being moved around a hospital. The patient’s body electronics unit 14 is just repaired with a new base station using the token key 132.

After the body electronics unit 14 and the base station 16 are paired, the body electronics unit 14 and the base station 16 will remain communicating with each other as long as the token key 132 remains in the token key port 134 of the base station 16 (or the token key port 136 of the body electronics unit 14, depending on the order of the pairing process). In other words, as soon as the token key 132 is removed from the base station 16, the electronics unit 14 and the base station 16 will discontinue or cease communication. Any specific token key 132 can be used to pair any specific base station 16 with any specific body electronics unit 14.

The outside casing of the base station 16 is constructed of lightweight, molded plastic, such as acrylonitrile-butadiene-styrene (ABS) or other suitable material. The shape and configuration of the base station 16 is not limited to any particular shape or configuration. The base station 16 is removably secured to an ECG monitor 138 via suitable mounting means, such as Velcro®, dual-lock strips, double-sided foam tape, or the like. Preferably, the base station 16 is removably mounted to a mounting plate secured near the ECG monitor 138 via suitable mounting means. As shown in FIG. 10, the base station 16 has a cradle 140 for storing the body electronics unit 14 when the body electronics unit 14 is not in use or otherwise off the patient. In addition, the base station 16 has a battery port 142 in which a base station battery 144 is removably inserted. The base station 16 may be constructed to have a plurality of battery ports that store and charge batteries when the batteries are not being used. When the base station 16 is not plugged into an AC wall power inlet, the base station battery 144 provides power to the base station 16. When the base station 16 is operating on AC wall power, the base station 16 charges the base station battery 144 when the base station battery 144 is in the battery port 142. The base station 16 has a power switch 146 that activates/deactivates the power to the base station 16 and a power cord connection 148 for connecting a power cord to an AC wall power inlet. The base station battery 144 is preferably a 3.6 V Li-ion rechargeable battery.

Accordingly, the base station battery **144** and the body electronics unit battery **104** are preferably identical and interchangeable, such that each battery can be used in either the body electronics unit **14** or the base station **16**. The system is designed such that a discharged body electronics unit battery **104** is swapped for a charged base station battery **144**. In this manner a charged battery is always readily available for the body electronics unit. In addition, the base station **16** has a lead switch **150** that allows the health care provider to instruct the base station **16** to operate in “7 lead” mode or “12 lead” mode.

As depicted in FIG. **11**, the base station **16** has a user interface **152** that provides information to the health provider or patient pertaining to the system’s operating status or functionality. For example, the user interface **152** may provide information on whether the body electronics unit **14** is communicating or transmitting normally to the base station **16**, whether the base station battery **144** is charging or the battery **144** is low, whether the body electronics unit battery **104** is low, or whether the power of the base station **16** is activated, whether the base station **16** is malfunctioning or otherwise requires servicing. In addition the user interface **102** may provide instructions on the correct order or procedure for pairing or coupling the body electronics unit **14** with the base station **16**. Such information may be communicated to the health care provider or patient via the user interface **152** in various ways, for example, LED’s, LCD, text, audible tones, etc. An exemplary embodiment of the user interface **102** is shown in FIG. **11a**.

Additionally, the base station has a self-test function which monitors the integrity of the primary functions including the microprocessor, data acquisition, internal voltage references, and radio functionality. In the event a failure is detected, the body electronics unit will capture the fault condition, stop data acquisition and transmission and indicate that fault has occurred through the lead off alarm.

A receiver **154** located within the base station **16** receives signals sent to the base station **16** from the body electronics unit **14**. As shown in FIG. **12**, the receiver **154** includes a radio **156**, a controller **158**, a digital-to-analog converter (DAC) **160**, a demultiplexer **162**, a transceiver **164**, and a plurality of electrode signal channels **166**. The radio **156** demodulates the received signals for identifying digital data representing the combined electrode signals. In an exemplary embodiment, the radio **156** includes a modulator for transmitting control information. The controller **158** controls operation of the various components and may further process the signals from the radio **156**, such as interpolating data, converting the signals to digital information, generating control signals for the transmitter **108** in the electronics unit **14**, operating any user output or input devices, and diagnosing operation of the ECG system. Preferably, the controller **118** interpolates the electrode signals to return the effective sample rate to about 3 kHz or another frequency. This enables the reconstruction filters to have a cutoff frequency many times the bandwidth of the electrode signals, thus minimizing any differences in group delay at the frequencies of interest, i.e. less than 150 Hz. The DAC **160** converts the digital signals to analog signals. The demultiplexer **162** separates the individual regenerated electrode signals onto the separate electrode signal channels **166**. The transceiver **164** operates operable pursuant to the Bluetooth specification for two-way communication with the transmitter **108**.

The receiver **154** has nine electrode signal channels **166** corresponding to the **10** electrodes connected to the chest assembly **12** and the precordial assembly **60**. The electrode

signal channels **166** each comprise a sample and hold circuit **168**, a filter **170**, and an attenuator **172**. The sample and hold circuit **168** is controlled by the controller **118** so that the converted electrode signals appear simultaneously on each electrode signal channel **166**. Other embodiments may include individual DAC’s that provide the signal substantially simultaneously. The filter **170** comprises a low pass reconstruction filter for removing high frequency signals associated with the DAC conversion process. The attenuator **172** comprises an amplifier for decreasing the amplitude to a level associated with signals at the electrodes, which were earlier amplified in the amplifiers of the body electronics unit **14**. This results in a unity system gain so as not to introduce error between the electrodes and the conventional ECG monitor.

The base station **16** transmits the ECG signals to the ECG monitor **138** via preexisting or conventional monitor cables **174**. In turn, the information is displayed on the ECG monitor and reviewed by a physician. As depicted in FIG. **13**, the monitor cables **174** removably insert onto snap terminals **176** located on the base station **16**. Preferably, the base station **16** has ten snap terminals **176** arranged on the left and right side of the base station **16**. The snap terminals **176** and the monitor cables **174** are preferably labeled and color-coded so that the monitor cables **174** are properly connected to the base station **16**. For instance, the five snap terminals **176** located on the left side of the base station **16** and the monitor cable **174** may be labeled as RL, LA, LL, RA, and V/V1. In addition, the five snap terminals **176** on the right side of the base station **16** and the monitor cable **174** may be labeled V2, V3, V4, V5, and V6. When the ECG system is operating in “7 lead” mode (i.e. only the chest assembly **12** is used) the monitor cable **174** is plugged into the five snap terminals **176** on the left side of the base station **16**. When the ECG system is operating in “12 lead” mode (i.e. both the chest assembly **12** and the precordial assembly **60** is used) both the monitor cables **174** are plugged into the snap terminals **176**—the top four snap terminals **176** on the left side of the base station **16** will be used for chest assembly electrodes and the remaining six snap terminals **176** will be used for precordial assembly electrodes.

There may be instances where a base station **16** will not be in every ward or hospital room for use with the body electronics unit **14**. In such instances, an adaptor assembly **178** may be used to connect the chest assembly **12** or the precordial assembly **60** to the ECG monitor **138**. In one exemplary embodiment, the adaptor assembly **178** allows the chest assembly **12** or precordial assembly **60** to be plugged directly into a conventional or existing telemetry transmitter. FIG. **14** depicts the adaptor assembly **178** having an assembly receptacle **180** that connects to the chest assembly **12** or the precordial assembly **60** and a telemetry box receptacle **182** that connects to a conventional or existing telemetry transmitter. In another exemplary embodiment, the adaptor assembly **178** allows the chest assembly **12** or precordial assembly **60** to be plugged directly into a conventional or existing ECG monitor trunk cables. FIG. **15** depicts the adaptor assembly **178** having an assembly receptacle **184** for connecting to the chest assembly **12** or the precordial assembly **60** and a cable assembly **185** for connecting to a conventional or existing ECG monitor trunk cable. The cable assembly **185** has a cable **186** that connects to a trunk cable adaptor **188** for connecting to an ECG monitor trunk cable. In another exemplary embodiment, the adaptor assembly **178** allows the chest assembly **12** or precordial assembly **60** to be plugged directly into standard lead wires that connect to an ECG

monitor. FIG. 16 depicts the adaptor 178 having an assembly receptacle 190 for connecting to the chest assembly 12 or the precordial assembly 60 and a lead wire cable assembly 192 for connecting to a lead wire assembly. The cable assembly 192 has a cable 194 that connects to a lead wire adaptor 196 for connecting to standard lead wires. Various configurations of the adapter 178 are possible depending on the connector configuration of the standard lead wires.

FIG. 17 depicts the method of monitoring the cardiac activity in the patient's heart using the wireless ECG system of the present invention. In step 198, electrodes are placed on the patient's body. In step 200, the chest assembly 12 and/or precordial assembly 60 are positioned on the patient's body by connecting the electrode connectors 21, 62 to the electrodes. In step 202, the chest assembly 12 and/or the precordial assembly 60 are plugged into the body electronics unit 14. In step 204, the electronics unit 14 and the base station 16 are paired or coupled by inserting the token key 132 into the base station 16, removing the token key 132 from the base station 16, inserting the token key 132 into the body electronics unit 14, removing the token key 132 from the electronics unit 14, and reinserting the token key 132 into the base station 16. Alternatively, coupling can be accomplished by inserting the token key 132 into the body electronics unit 14, removing the token key 132 from the body electronics unit, inserting the token key 132 into the base station 16, removing the token key 132 from the base station 16 and reinserting the token key 132 into the body electronics unit 14. In step 206, electrical signals from the patient's heart are detected and transmitted to the body electronics unit 14 via chest assembly 12 and the precordial assembly 60. In step 208, the electrical signals from the heart are transformed by the body electronics unit 14 from analog signals to digital signals. In step 210, the body electronics unit 14 transmits the digital signals to the base station 16 via radio transmission. In step 212, the base station 16 transforms the digital signals into analog signals. In step 214, the base station 16 transmits the analog signals to the ECG monitor 138 via monitor cables 174. In step 216, the ECG monitor 138 processes the analog signals into meaningful information that can be displayed on the monitor 138.

In the foregoing specification, the present invention has been described with reference to specific exemplary embodiments thereof. It will be apparent to those skilled in the art, that a person understanding this invention may conceive of changes or other embodiments or variations, which utilize the principles of this invention without departing from the broader spirit and scope of the invention. The specification and drawings are, therefore, to be regarded in an illustrative rather than restrictive sense. Accordingly, it is not intended that the invention be limited except as may be necessary in view of the appended claims.

We claim:

1. A system for converting a conventional, non-wireless electrocardiograph monitoring system to a wireless electrocardiograph monitoring system comprising:

a body electronics unit for acquiring electrical signals from a chest or precordial assembly and wirelessly transmitting the electrical signals to a base station, the base station having a plurality of terminals for directly transmitting the electrical signals to any conventional electrocardiograph monitor, the base station having a user interface for communicating information to the user and further comprising an apparatus for pairing the base station with the body electronics unit wherein the apparatus is a removable token key being

physically separable from said body electronics unit and said base station.

2. The system of claim 1 wherein the base station controls the data collected by the chest assembly.

3. The system of claim 1 wherein the chest assembly has five electrode connectors for connecting to electrodes.

4. The system of claim 3 wherein an electrode is positioned on the right side of a patient's chest about level of the first and second intercostal space, an electrode is positioned on the left side of the patient's chest about level of the first and second intercostals space, an electrode is positioned in the middle of the patient's chest about level of the fourth and fifth intercostals space, and two electrodes are positioned on the left side of the patient's torso.

5. The system of claim 1 wherein the on body electronics unit and the base station each have a battery port for removably retaining a battery.

6. The system of claim 5 wherein the battery is compatible with the battery port of the body electronics unit and the battery port of the base station.

7. A method of pairing the body electronics unit of claim 1 with the base station by:

inserting the token key into a token key port of the base station to record an identification number of the base station;

removing the token key from the token key port of the base station;

inserting the token key into the token key port of the body electronics unit to record an identification number of the body electronics unit and to transmit the identification number of the base station to the body electronics unit;

removing the token key port from the token key port of the body electronics unit;

and inserting the token key into the token key port of the base station to transfer the identification number of the body electronics unit to the base station.

8. A method of pairing the body electronics unit of claim 1 with the base station by

inserting the token key into the token key port of the body electronics unit to record an identification number or the body electronics unit;

removing the token key from the token key port of the body electronics unit;

inserting the token key into a token key port of the base station to record an identification number of the base station and to transmit the identification number of the body electronics unit to the base station;

removing the token key port from the token key port of the base station; and

inserting the token key into the token key port of the body electronics to transfer the identification number of the base station to the body electronics unit.

9. A system for monitoring cardiac activity in a patient comprising, in combination:

an assembly having a plurality of electrode connectors removably connected to a plurality of electrodes that detect electrical signals from a patient's heart;

a body electronics unit removably connected to the assembly, the body electronics unit acquiring the electrical signals from the assembly and transmitting the electrical signals to a base station via radio transmission, the body electronics unit having a user interface for communicating information to the user;

the base station including a receiver for receiving the electrical signals and a plurality of terminals for

15

directly connecting to an electrocardiograph monitor via monitor cables, the base station having a user interface for communicating information to the user and further comprising a removable token key for pairing the body electronics unit with the base station, said token key being physically separable from said body electronics unit and said base station.

10. The system of claim 9 wherein the user interfaces of the body electronics unit and the base station communicate information pertaining to the system's operating status.

11. The system of claim 9 wherein the base station includes a cradle for storing the body electronics unit.

12. A system for monitoring cardiac activity in a patient comprising, in combination:

a chest assembly having a plurality of electrode connectors removably connected to a plurality of electrodes that detects electrical signals from a patient's heart;

a precordial assembly having a plurality of electrode connectors removably connected to a plurality of electrodes that detect electrical signals from a patient's heart;

a body electronics unit removably connected to the chest assembly connector and the precordial assembly connector, the body electronics unit receiving the electrical signals from the chest assembly and the precordial assembly;

a base station for acquiring the electrical signals from the body electronics unit via radio frequency transmission, the base station having a plurality of terminals the connecting to electrocardiograph monitor cables, the electrical signals transmitted to an electrocardiograph monitor via the electrocardiograph monitor cables further comprising a removable token key for pairing the body electronics unit with the base station wherein said token key is physically separable from said body electronics unit and said base station.

13. The system of claim 12 wherein the body electronics unit includes a user interface for communicating information to the user.

14. The system of claim 12 wherein the base station includes a user interface for communicating information to the user.

15. The system of claim 12 wherein the base station includes a cradle for storing the body electronics unit.

16. A system for wireless transmission of physiological signals from a physiological sensor to a monitor comprising:

a body electronics unit, the physiological sensor removably coupled to the body electronics unit, the physiological signals transmitted to the body electronics unit whereby the body electronics unit wirelessly transmits the physiological signals to a base station, the base station having a plurality of terminals for directly transmitting the physiological signals to any conventional monitor, the base station having a user interface for communicating information to the user and further comprising a token key for pairing the body electronics unit with the base station, said removable token key

16

physically separable from said body electronics unit and said base station.

17. The system of claim 16 wherein the physiological signals pertain to information selected from the group consisting of pulse, respiration rate, heart rate, temperature, EEG signals, and pulse oximeter signals.

18. A base station for use in a system for monitoring cardiac activity in a patient comprising:

a receiver for receiving electrical signals sent from a body electronics unit; and

a plurality of terminals for directly connecting to conventional electrocardiograph monitor cables for transmitting the electrical signals to a conventional electrocardiograph monitor and a removable token key for pairing the body electronics unit to the base station.

19. The base station of claim 18 further comprising a user interface for communicating information to a user.

20. The base station of claim 19 wherein the information pertains to the system's operating status.

21. The base station of claim 18 further comprising a battery port for removably receiving a base station battery.

22. The base station of claim 21 wherein the base station battery is interchangeable with a body electronics unit battery.

23. The base station of claim 18 further comprising a lead switch for instructing the base station to operate in either a 7 lead mode or 12 lead mode.

24. The base station of claim 18 wherein the base station is removably secured to an ECG monitor.

25. A method of monitoring the cardiac activity in a patient comprising the steps of:

positioning a chest assembly on a patient's body, the chest assembly having a plurality of electrode connectors for connecting to a plurality of electrodes;

plugging the chest assembly into a body electronics unit, the body electronics unit having a user interface that communicates information to a user and wherein the body electronics unit is activated by plugging the chest assembly into the body electronics unit;

pairing the body electronics unit with a base station through the use of a removable token key;

detecting electrical signals from the patient's heart with the chest assembly;

transmitting the electrical signals from the chest assembly to the body electronics unit;

transforming the electrical signals from analog signals into digital signals;

transmitting the digital signals to the base station via radio transmission, the base station having a user interface for communicating information to the user and a plurality of terminals for transmitting the electrical signals to an electrocardiograph monitor;

transforming the digital signals into analog signals; and

transmitting the analog signals directly to the electrocardiograph monitor via the terminals.

\* \* \* \* \*

UNITED STATES PATENT AND TRADEMARK OFFICE  
**CERTIFICATE OF CORRECTION**

PATENT NO. : 7,197,357 B2  
APPLICATION NO. : 09/998733  
DATED : March 27, 2007  
INVENTOR(S) : Istvan et al.

Page 1 of 1

It is certified that error appears in the above-identified patent and that said Letters Patent is hereby corrected as shown below:

On the title page (73), delete "Life Sync" and insert therefor --LifeSync--.

Signed and Sealed this

Twenty-second Day of May, 2007

A handwritten signature in black ink on a light gray dotted background. The signature reads "Jon W. Dudas" in a cursive style.

JON W. DUDAS  
*Director of the United States Patent and Trademark Office*

专利名称(译)	无线心电图系统		
公开(公告)号	<a href="#">US7197357</a>	公开(公告)日	2007-03-27
申请号	US09/998733	申请日	2001-11-30
[标]申请(专利权)人(译)	GMP强心保健公司		
申请(专利权)人(译)	GMP公司, INC.		
当前申请(专利权)人(译)	LIFE SYNC CORPORATION		
[标]发明人	ISTVAN RUD GREGORY BILL SOLOVAY KENNETH CHASTAIN DAVID PAUL GUNDLACH JOHN DAVID HOPMAN NICHOLAS C WILLIAMS DANIEL L LODATO FRANCO SALEM MICHAEL		
发明人	ISTVAN, RUD GREGORY, BILL SOLOVAY, KENNETH CHASTAIN, DAVID PAUL GUNDLACH, JOHN DAVID HOPMAN, NICHOLAS C. WILLIAMS, DANIEL L. LODATO, FRANCO SALEM, MICHAEL		
IPC分类号	A61B5/04 A61B5/00 A61B5/0408		
CPC分类号	A61B5/04085 A61B5/0006		
其他公开文献	US20030105403A1		
外部链接	<a href="#">Espacenet</a> <a href="#">USPTO</a>		

摘要(译)

心脏监测系统，更具体地，无线心电图（ECG）系统。本发明检测来自患者心脏的电信号，并通过遥测技术将信号数字地发送到远程基站。基站将数字信号转换回可由ECG监视器读取的模拟电信号。

