



(19) **United States**

(12) **Patent Application Publication**
Teixeira

(10) **Pub. No.: US 2012/0277545 A1**

(43) **Pub. Date: Nov. 1, 2012**

(54) **PROBABILISTIC BIOMEDICAL
PARAMETER ESTIMATION APPARATUS
AND METHOD OF OPERATION THEREFOR**

(52) **U.S. Cl. 600/301**

(57) **ABSTRACT**

(75) **Inventor: Rodrigo E. Teixeira, Madison, AL (US)**

A probabilistic digital signal processor for medical function is described. Initial probability distribution functions are input to a dynamic state-space model, which operates on state and/or model probability distribution functions to generate a prior probability distribution function, which is input to a probabilistic updater. The probabilistic updater integrates sensor data with the prior to generate a posterior probability distribution function passed to a probabilistic sampler, which estimates one or more parameters using the posterior, which is output or re-sampled in an iterative algorithm. For example, the probabilistic processor operates using a physical model on data from a medical meter, where the medical meter uses a first physical parameter, such as blood oxygen saturation levels from a pulse oximeter, to generate a second physical parameter not output by the medical meter, such as a heart stroke volume, a cardiac output flow rate, and/or a blood pressure.

(73) **Assignee: Streamline Automation, LLC, Huntsville, AL (US)**

(21) **Appl. No.: 13/096,876**

(22) **Filed: Apr. 28, 2011**

Publication Classification

(51) **Int. Cl. A61B 5/00 (2006.01)**

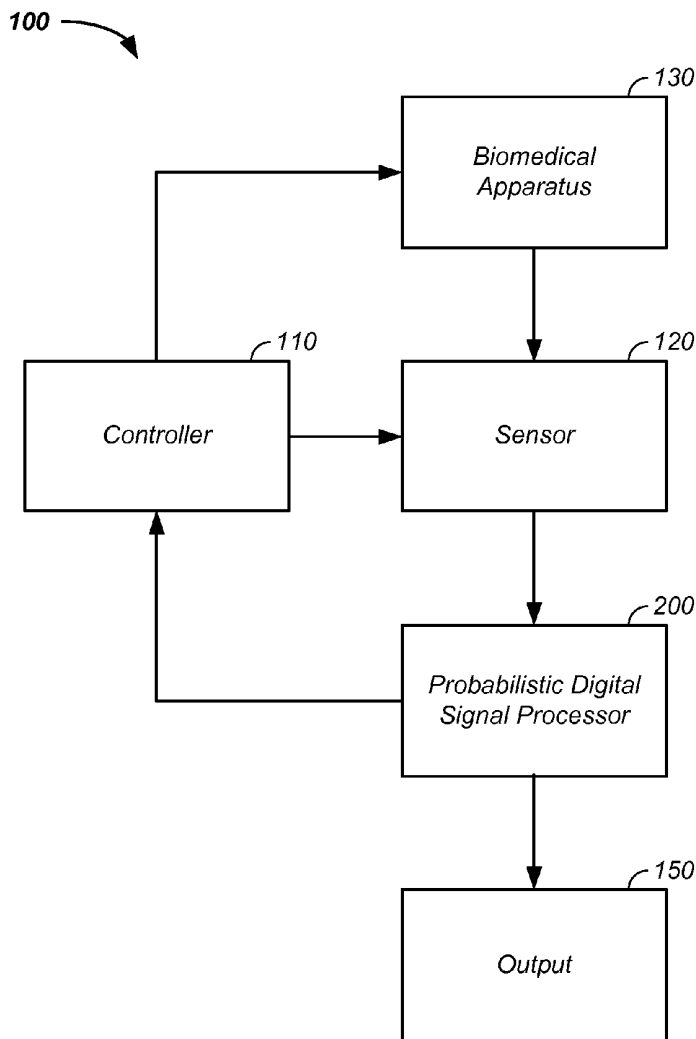

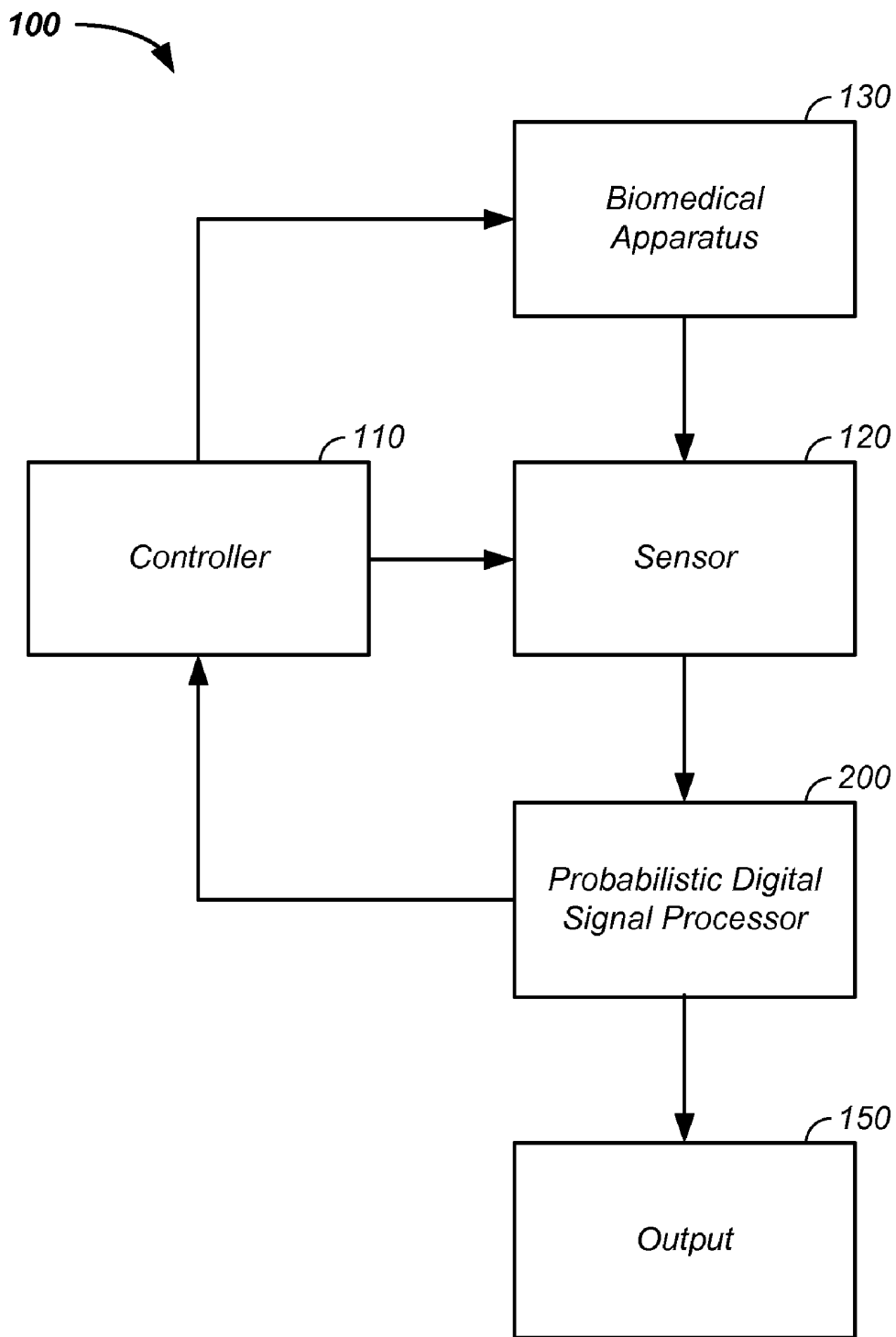

FIG. 1

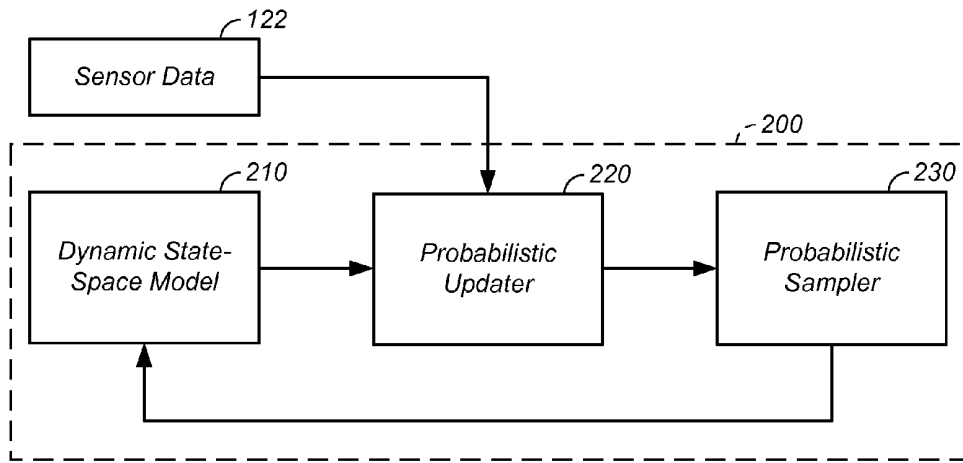

FIG. 2

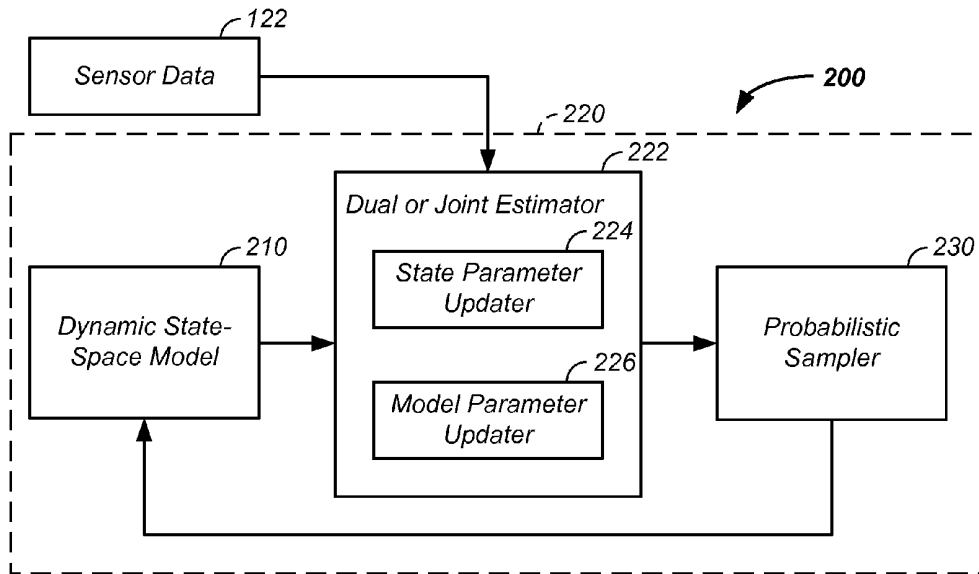

FIG. 4

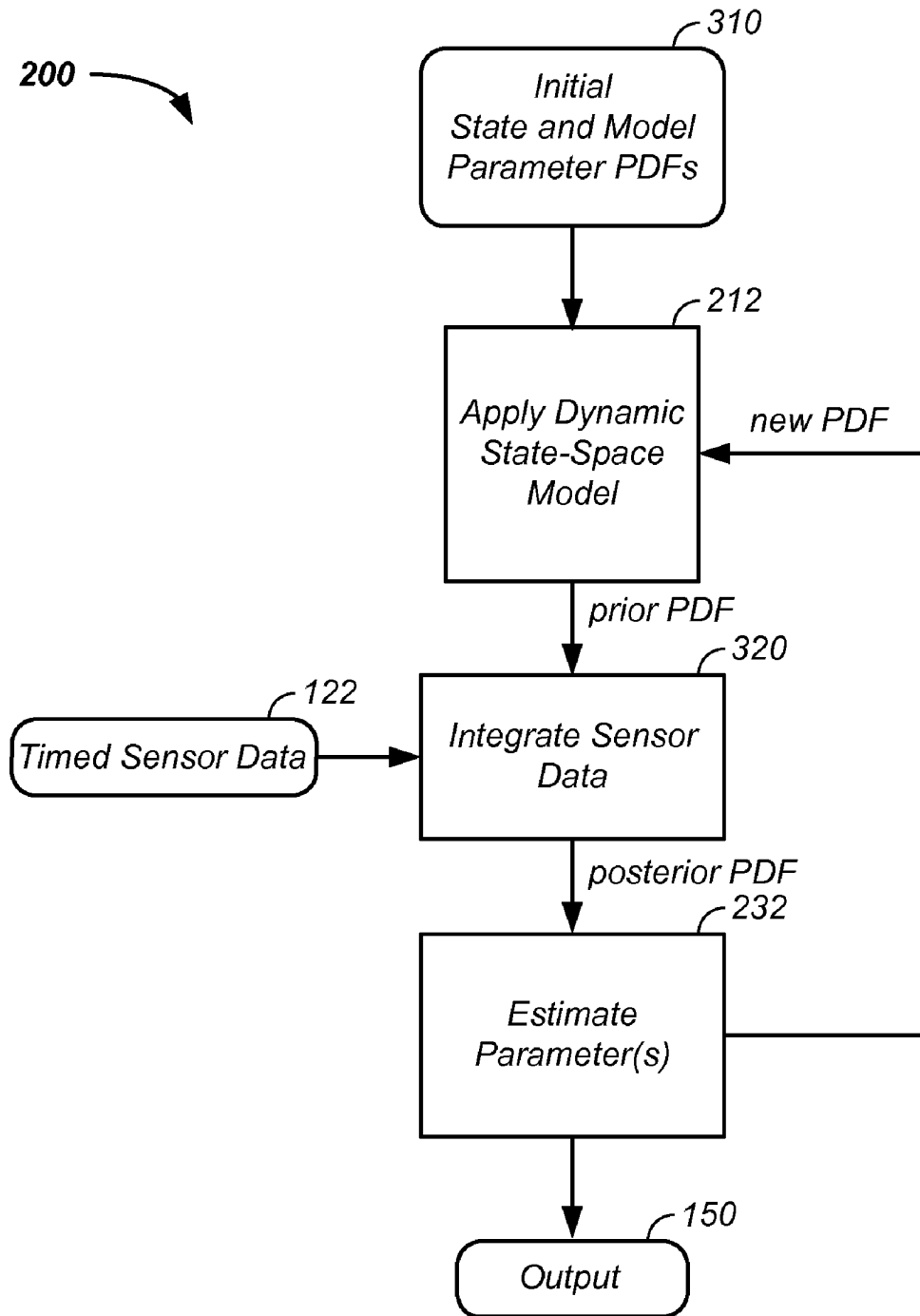

FIG. 3

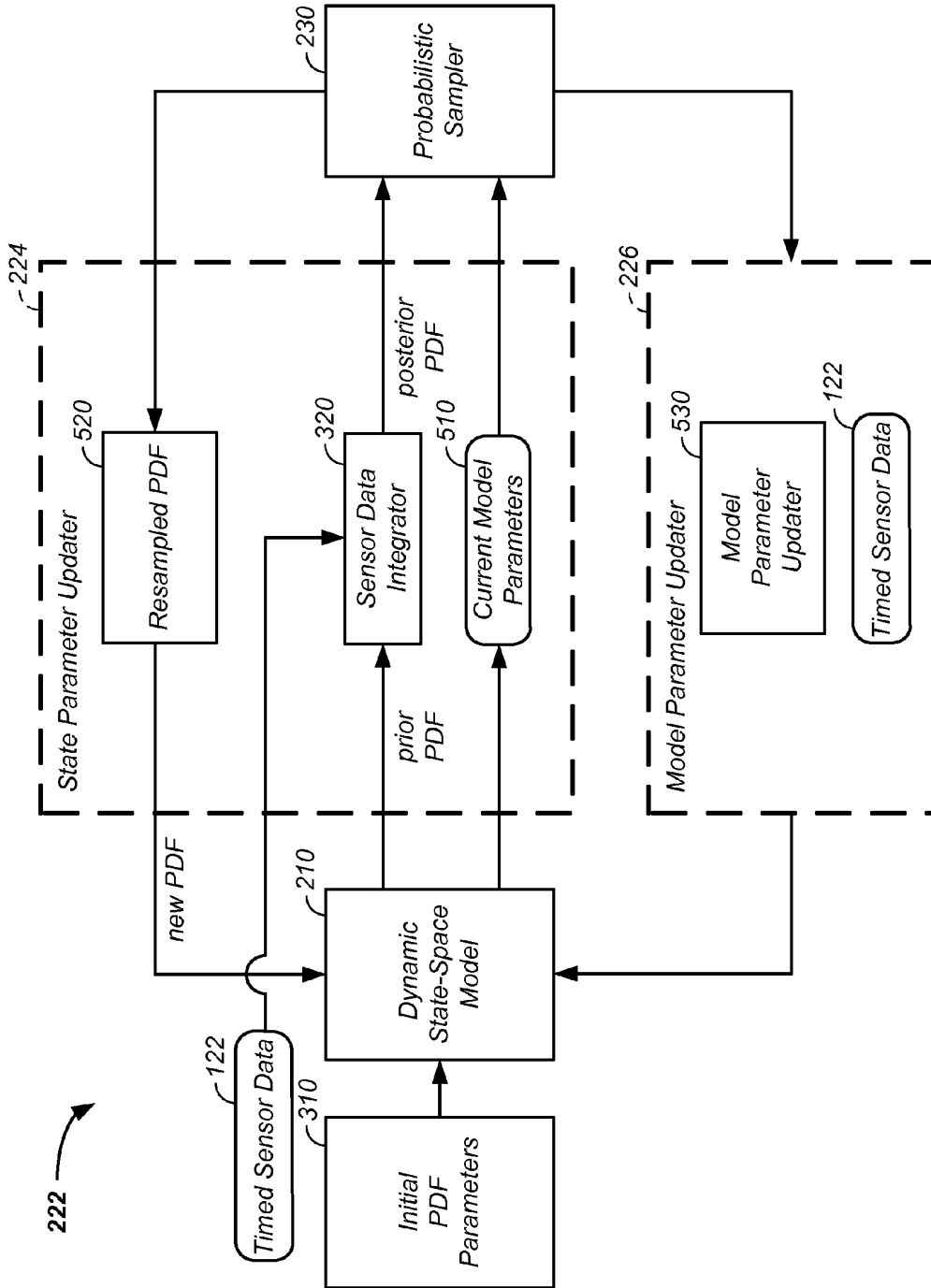

FIG. 5

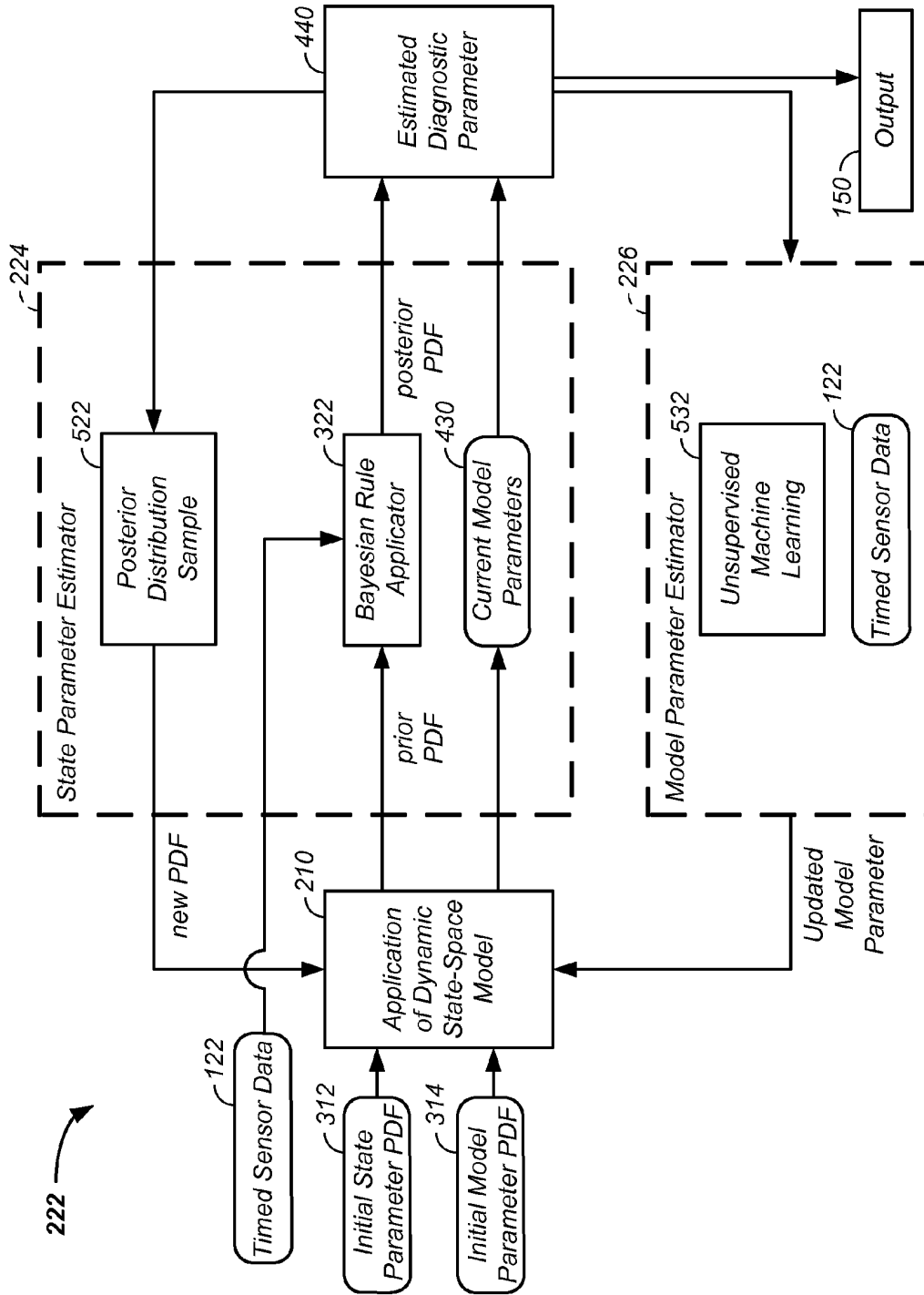

FIG. 6

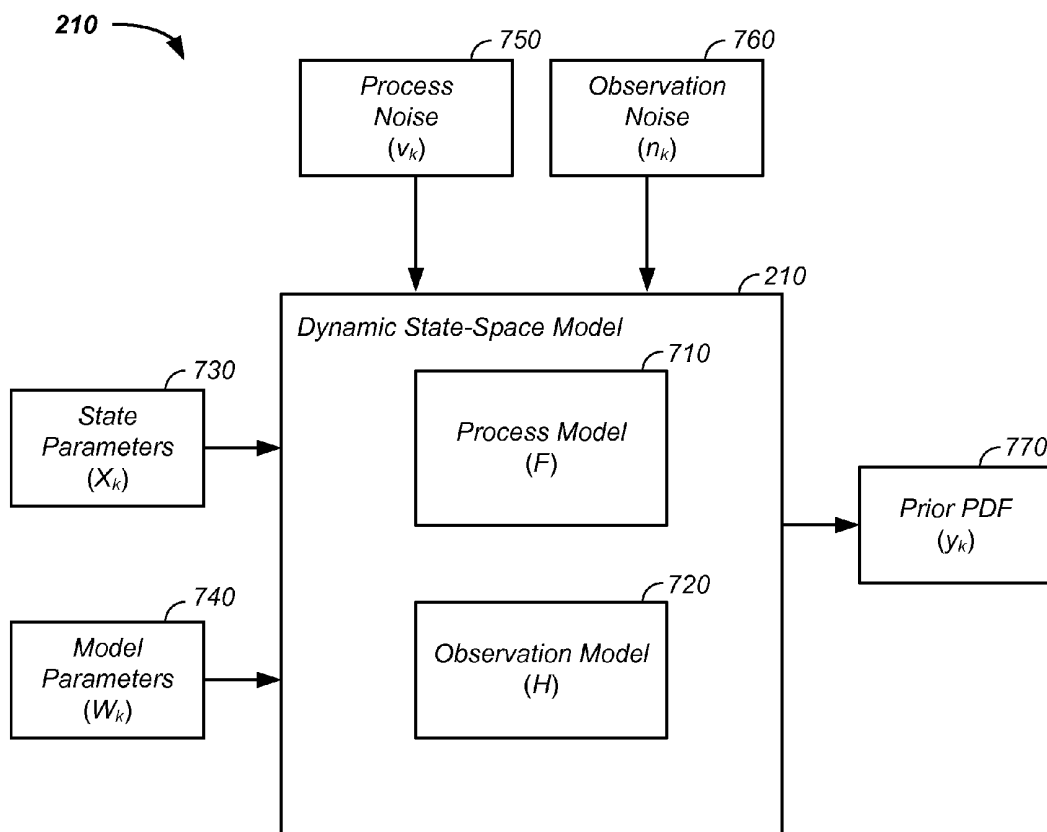

FIG. 7

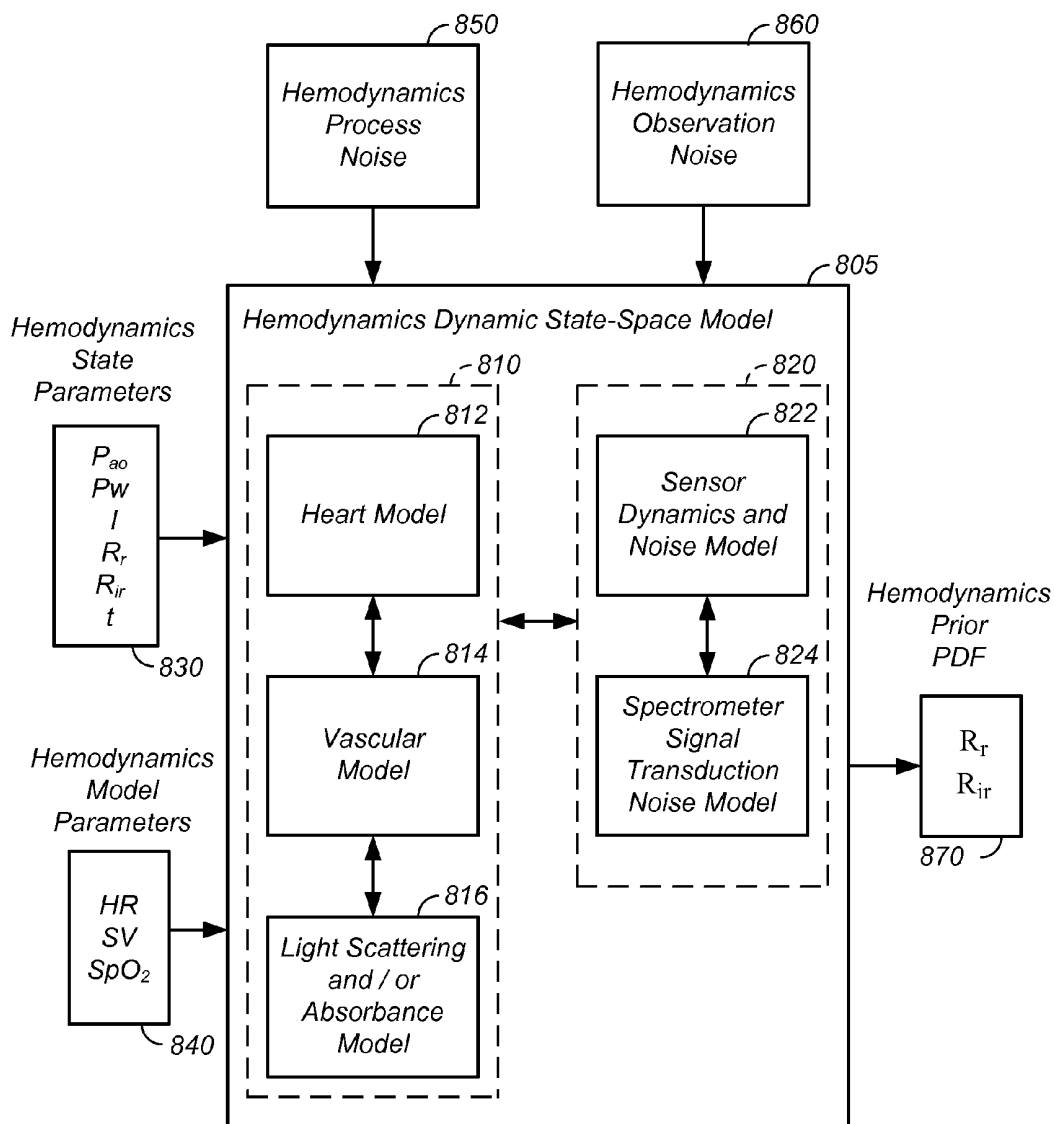

FIG. 8

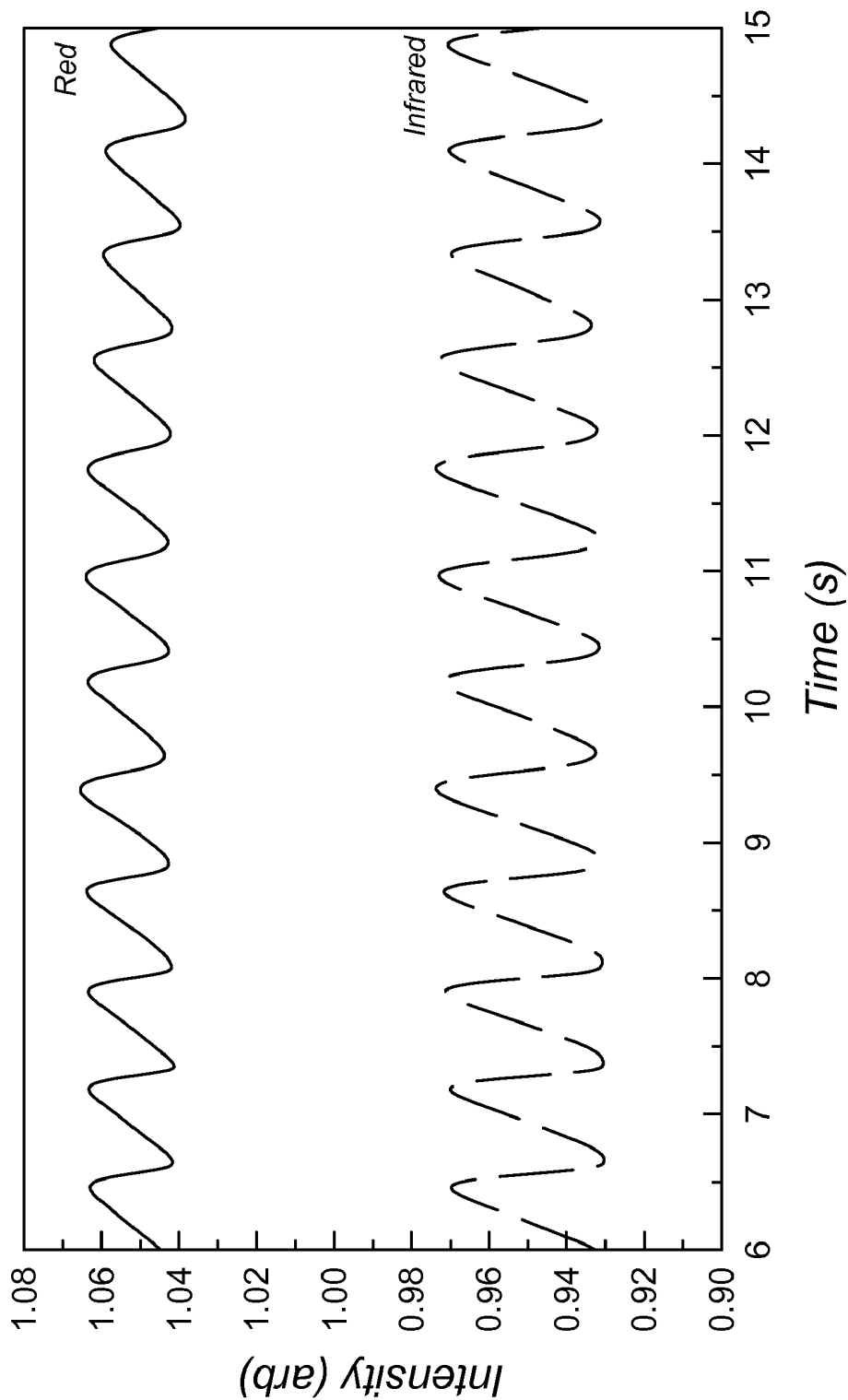

FIG. 9A

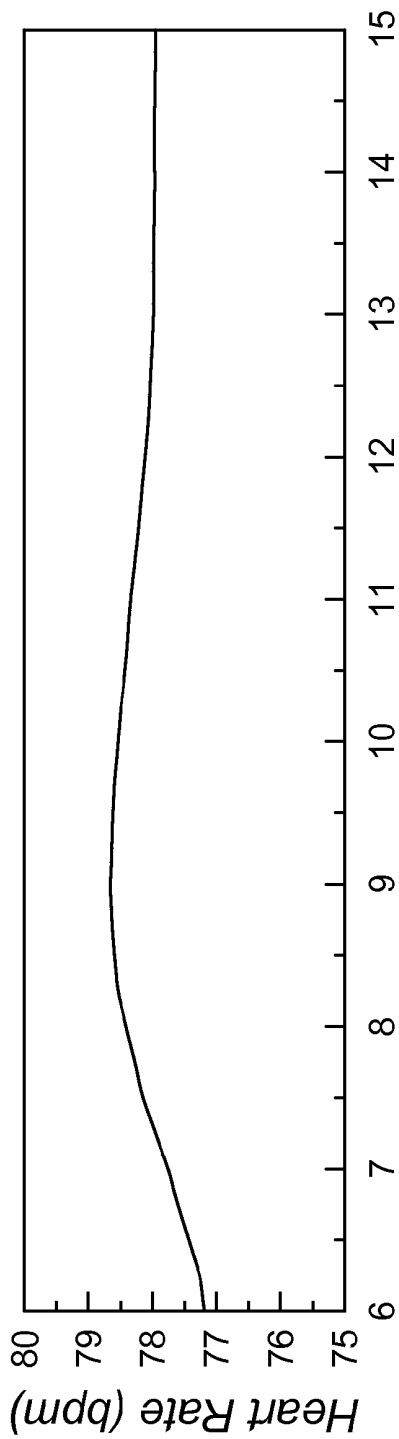

FIG. 9B

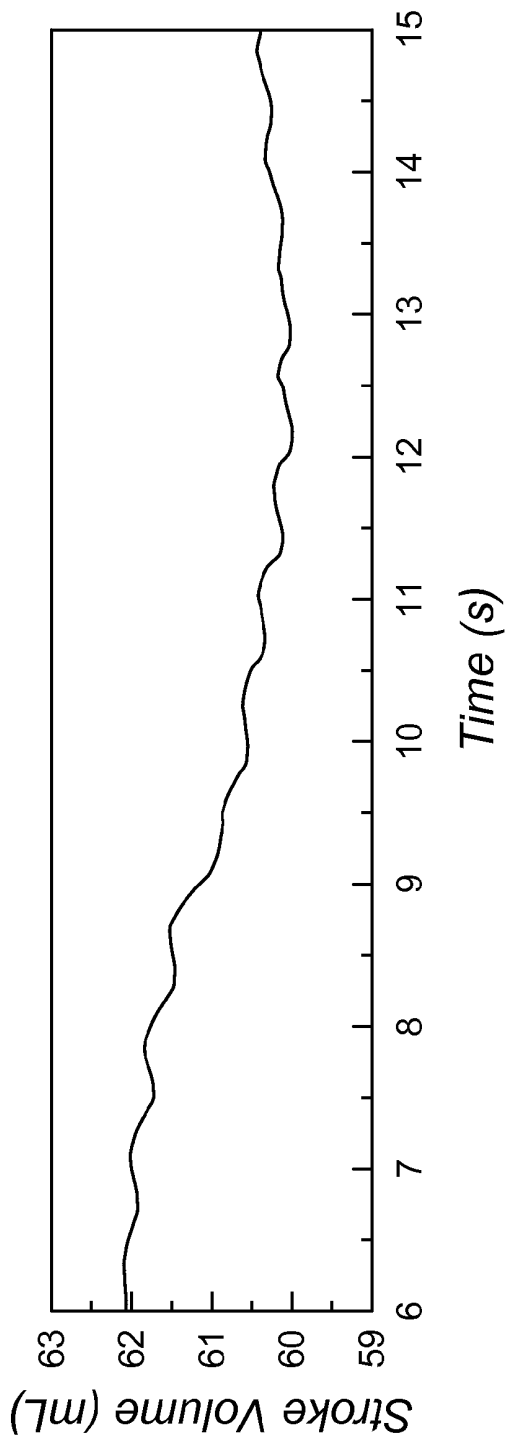

FIG. 9C

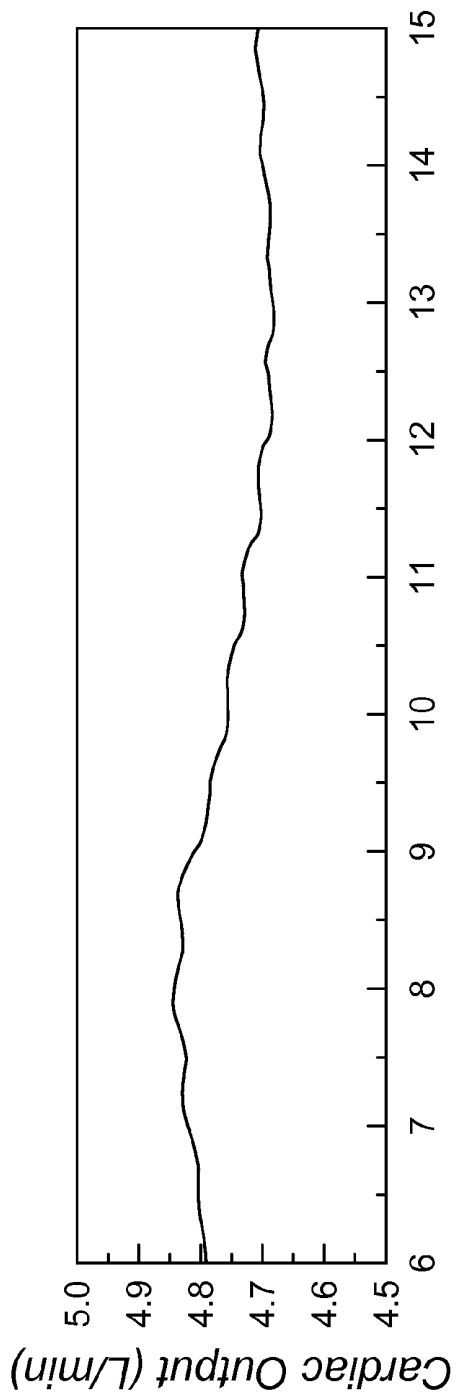

FIG. 9D

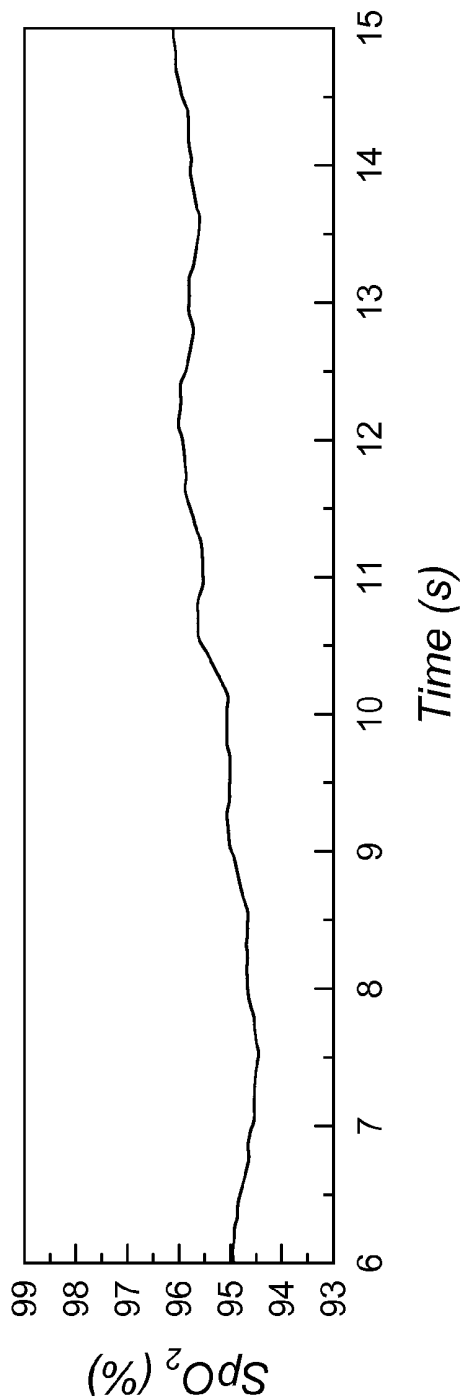

FIG. 9E

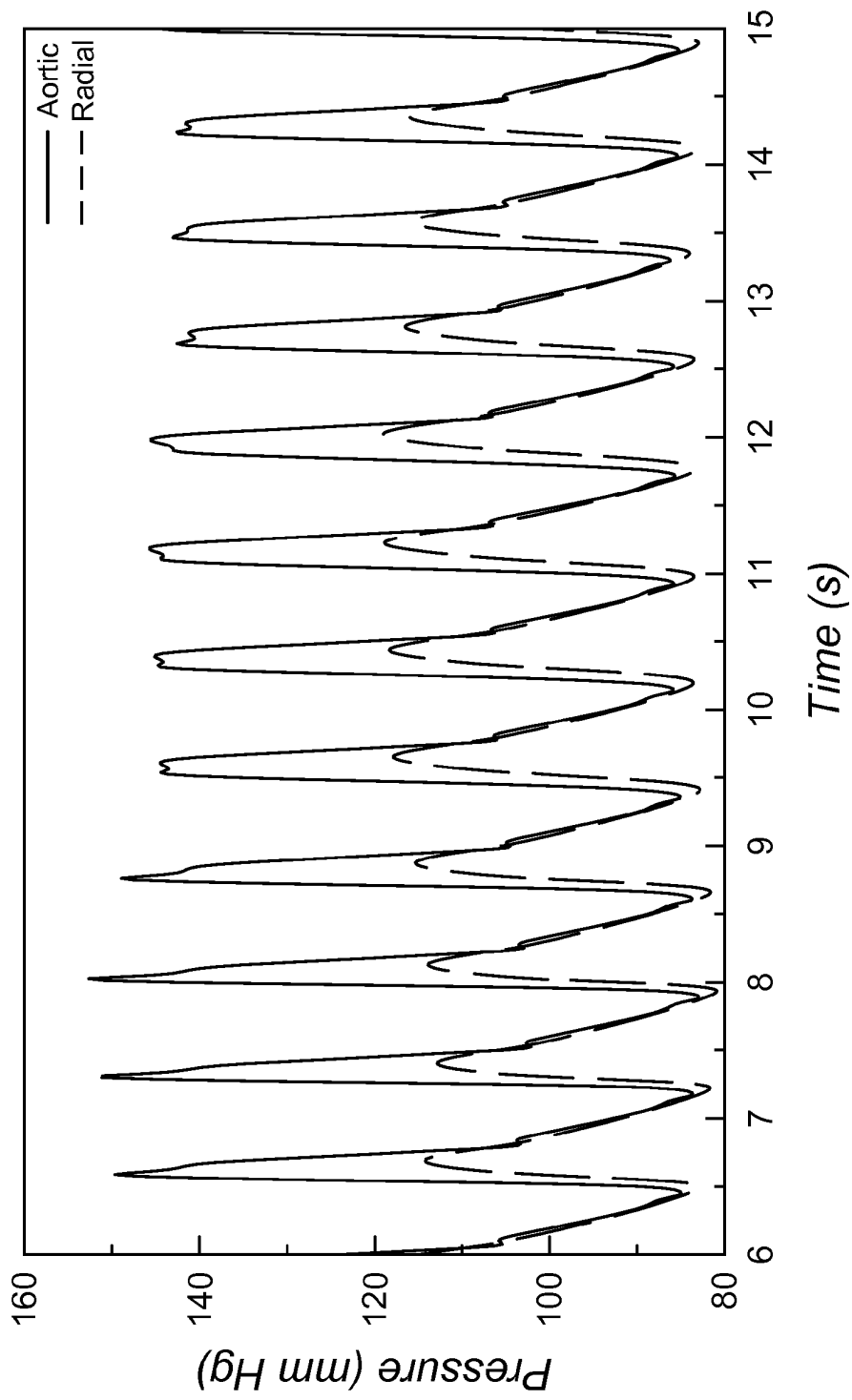

FIG. 9F

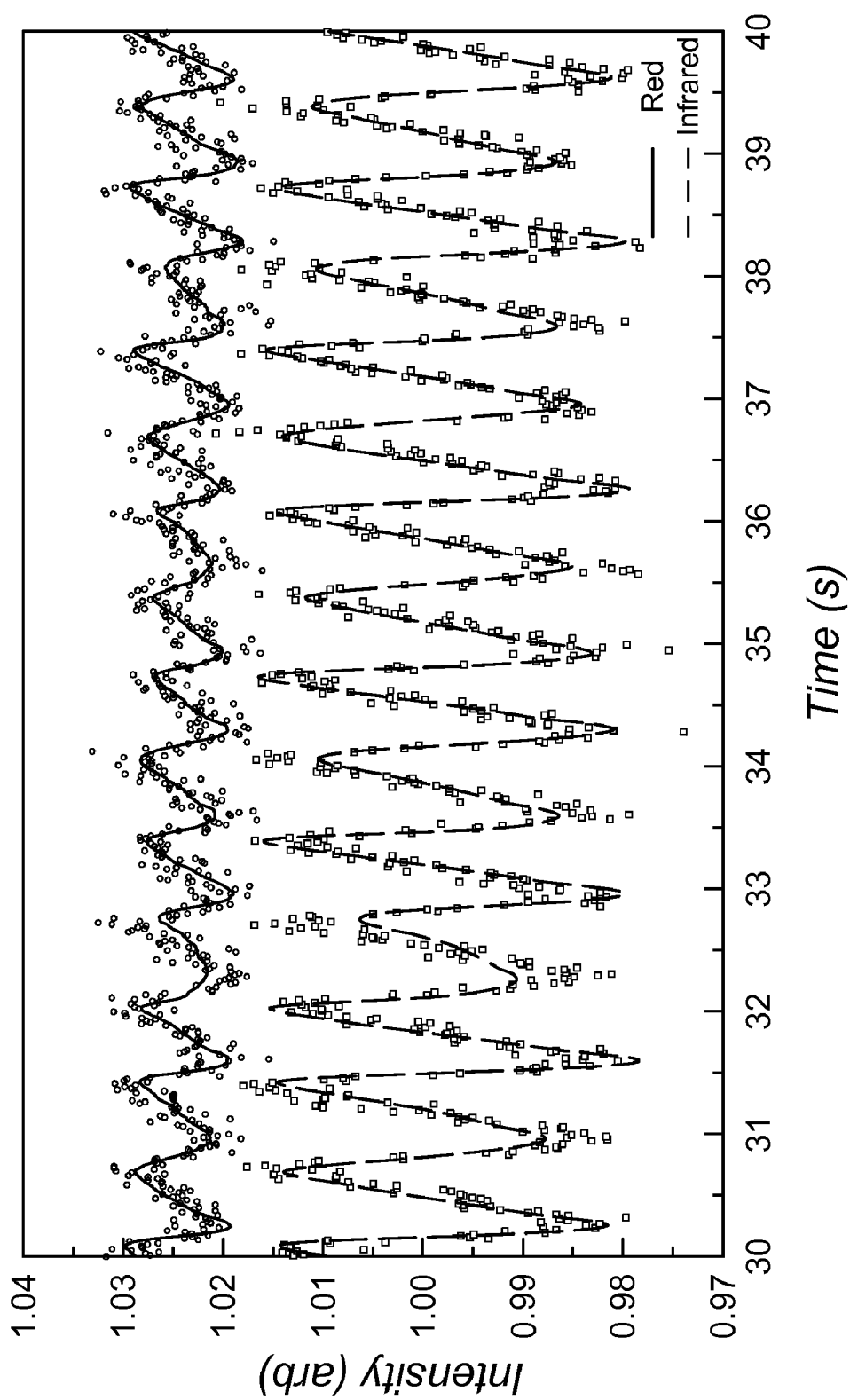

FIG. 10A

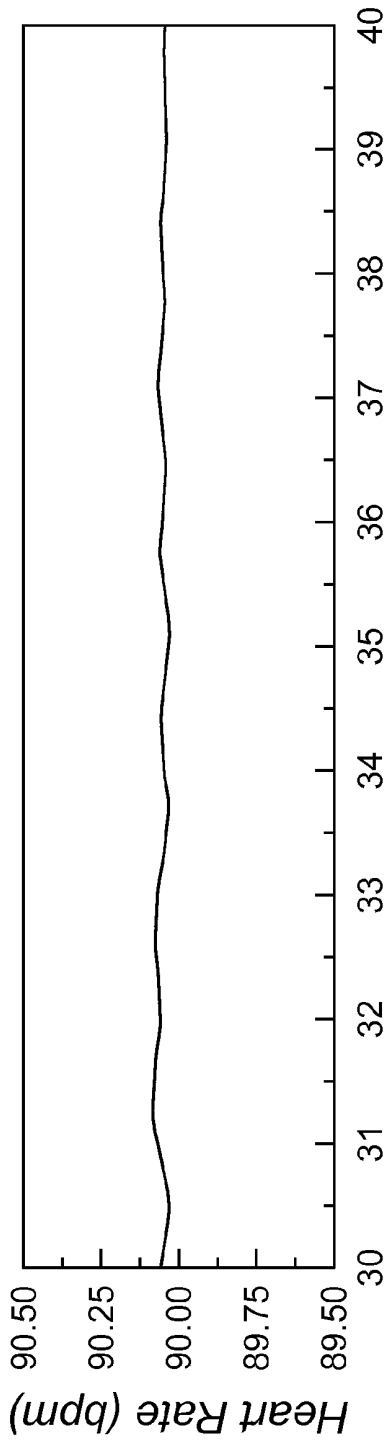

FIG. 10B

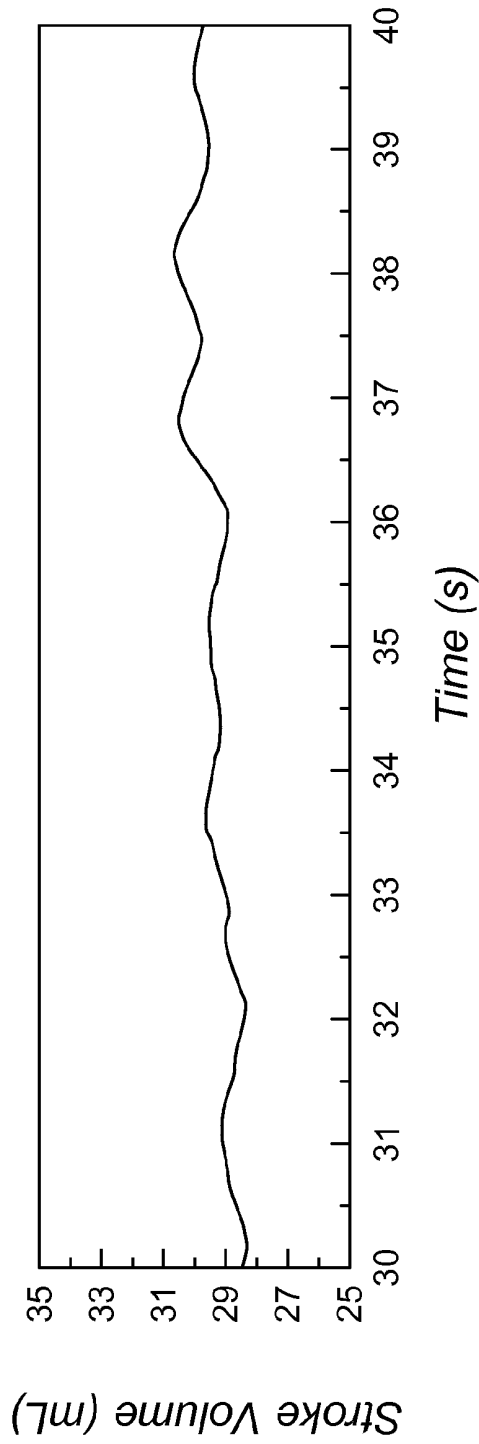

FIG. 10C

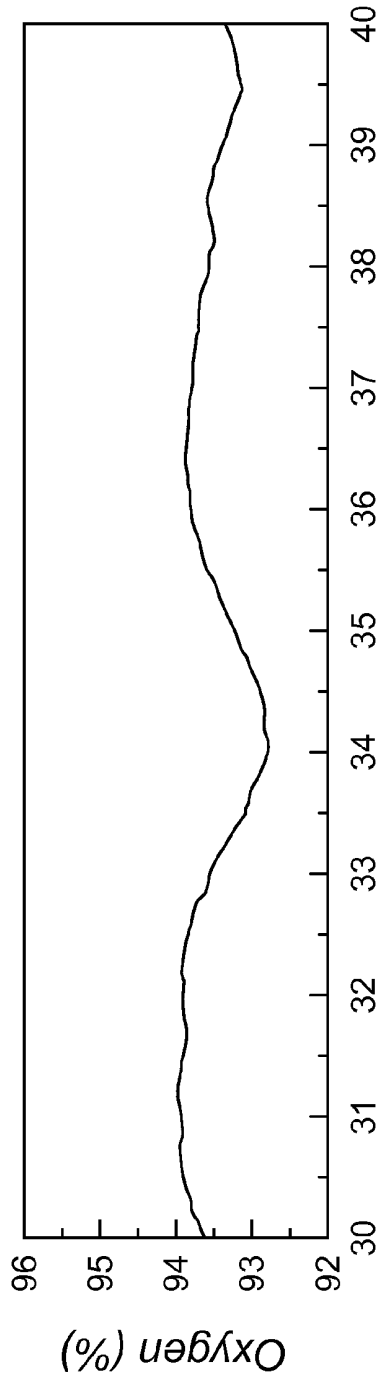

FIG. 10D

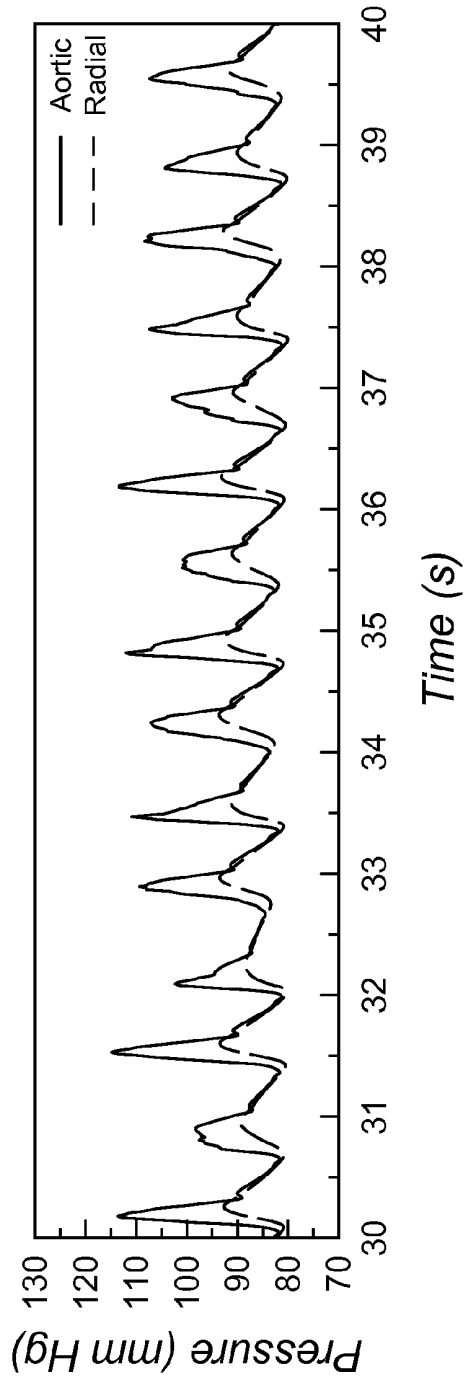

FIG. 10E

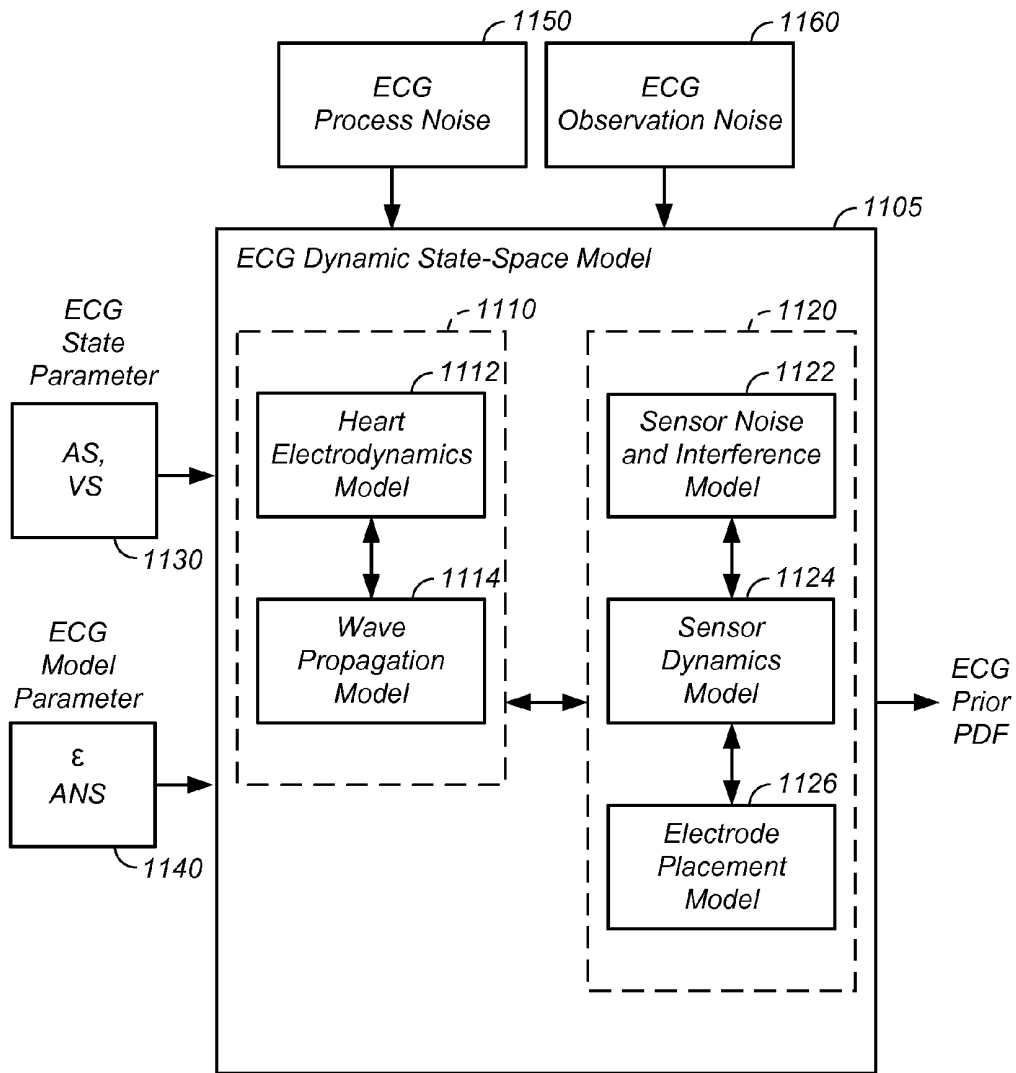

FIG. 11

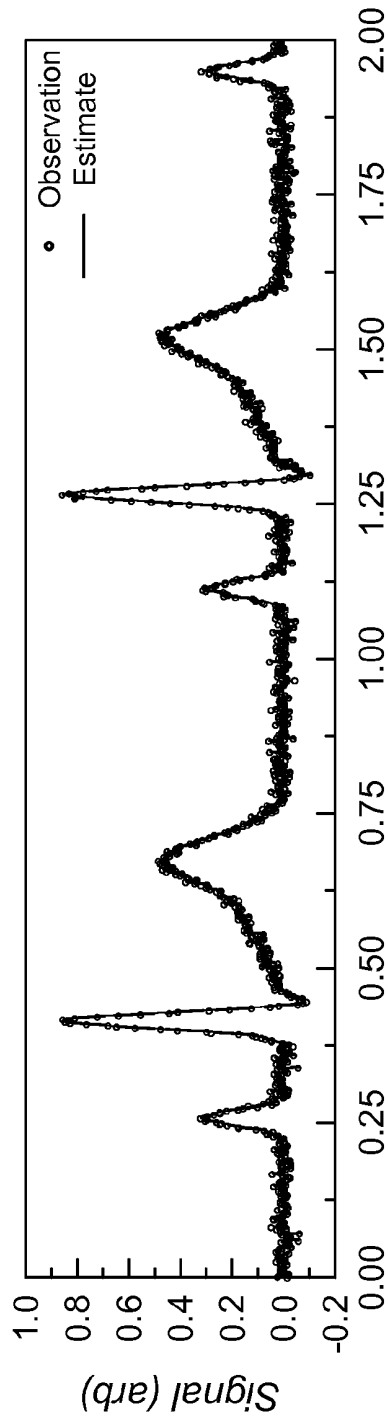

FIG. 12A

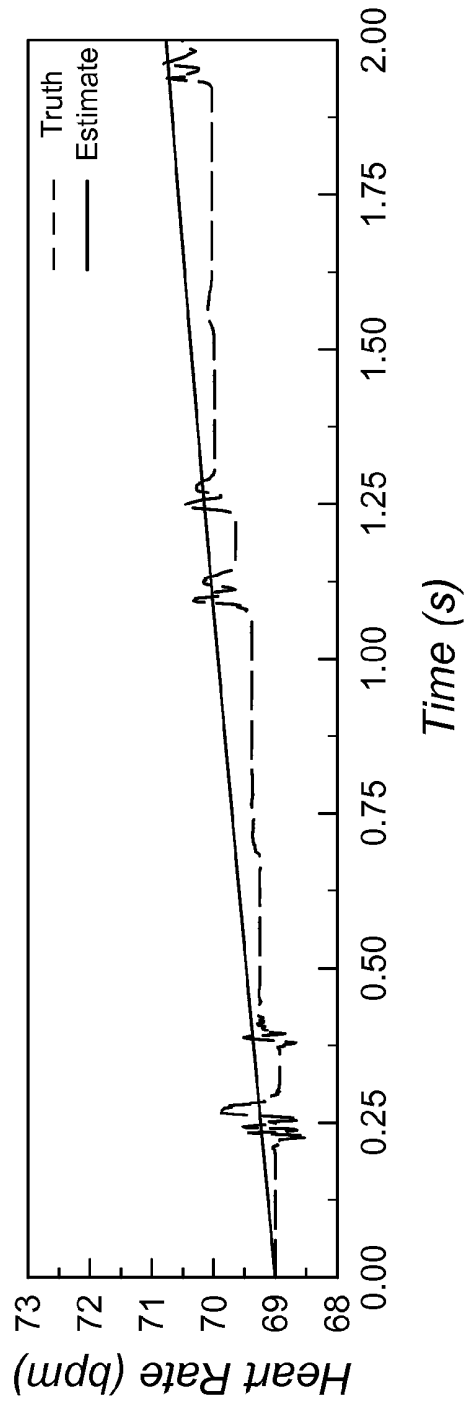

FIG. 12B

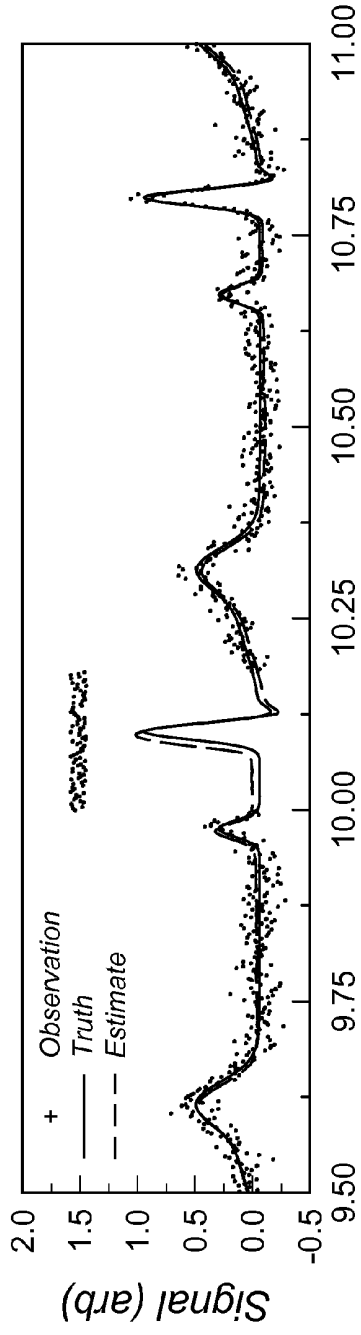

FIG. 13A

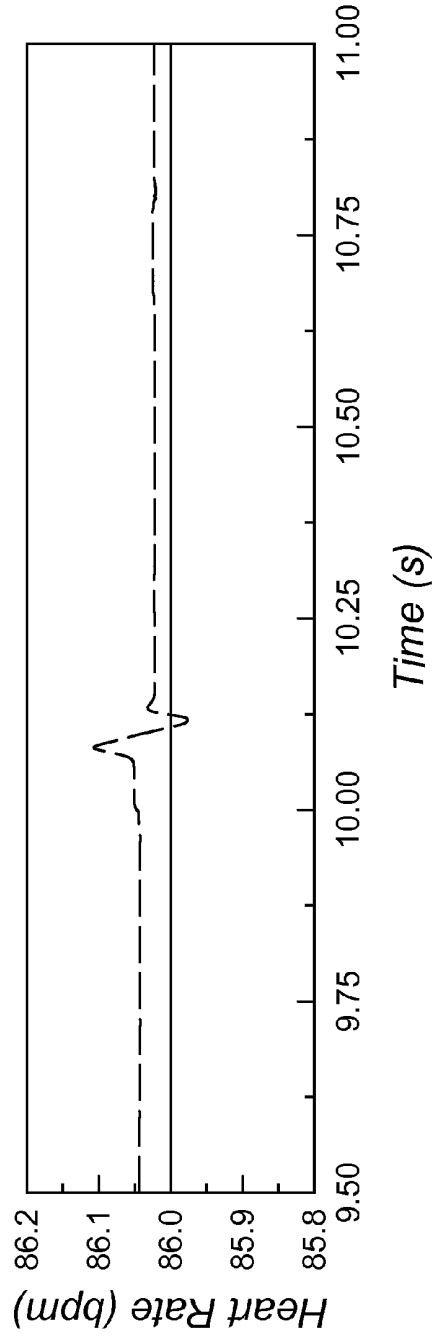

FIG. 13B

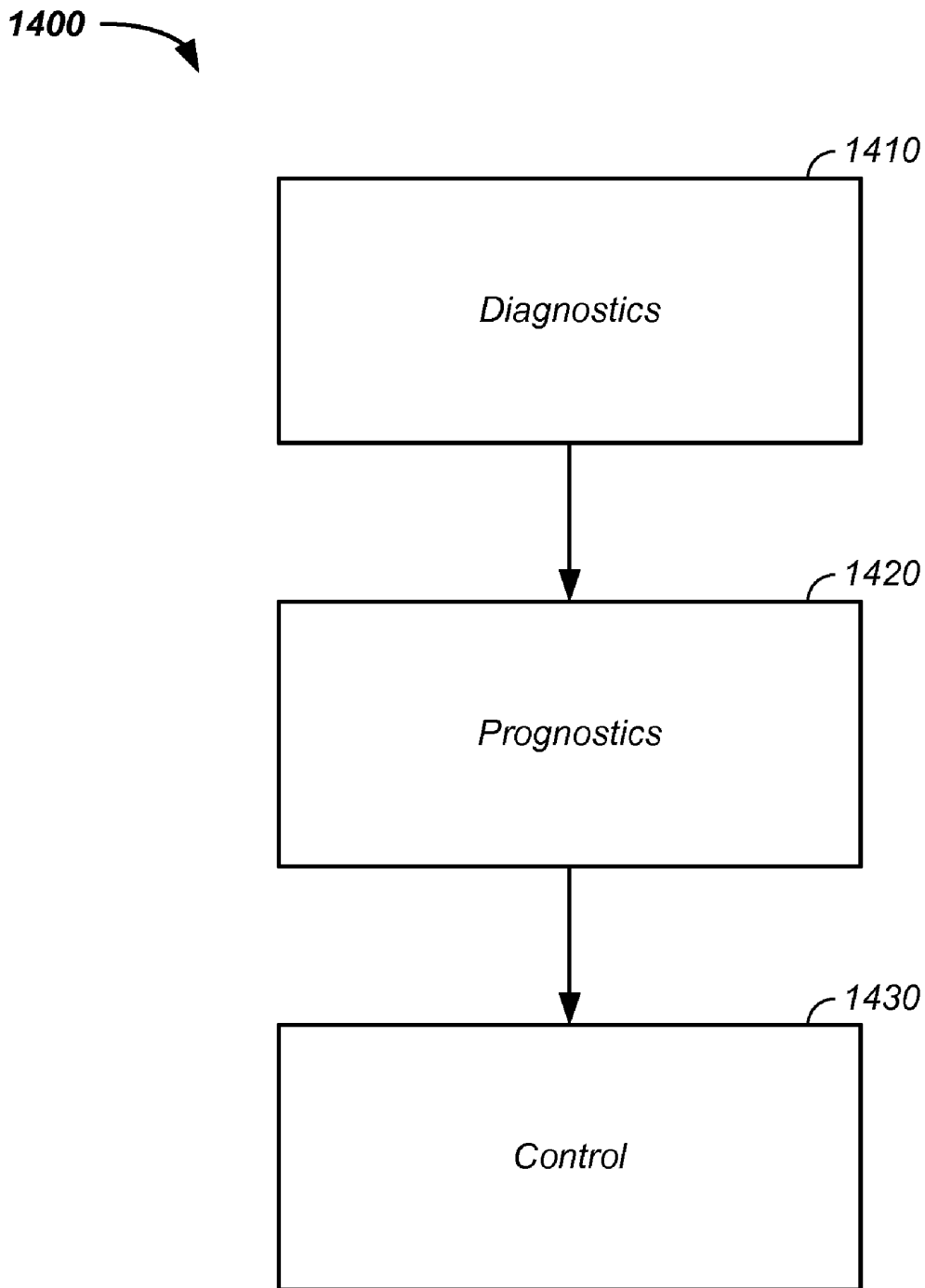

FIG. 14

**PROBABILISTIC BIOMEDICAL
PARAMETER ESTIMATION APPARATUS
AND METHOD OF OPERATION THEREFOR**

CROSS-REFERENCES TO RELATED
APPLICATIONS

- [0001]** This application claims:
[0002] priority to U.S. patent application Ser. No. 12/796,512, filed Jun. 8, 2010, which claims priority to U.S. patent application Ser. No. 12/640,278, filed Dec. 17, 2009, which under 35 U.S.C. 120 claims benefit of U.S. provisional patent application No. 61/171,802, filed Apr. 22, 2009,
[0003] benefit of U.S. provisional patent application No. 61/366,437 filed Jul. 21, 2010;
[0004] benefit of U.S. provisional patent application No. 61/372,190 filed Aug. 10, 2010; and
[0005] benefit of U.S. provisional patent application No. 61/373,809 filed Aug. 14, 2010,
[0006] all of which are incorporated herein in their entirety by this reference thereto.

STATEMENT REGARDING FEDERALLY
SPONSORED RESEARCH OR DEVELOPMENT

- [0007]** The U.S. Government may have certain rights to this invention pursuant to Contract Number IIP-0839734 awarded by the National Science Foundation.

BACKGROUND OF THE INVENTION

- [0008]** 1. Field of the Invention
[0009] The present invention relates generally to apparatus and methods for processing and/or representing physiological sensor data.
[0010] 2. Discussion of the Related Art
[0011] Biomedical monitoring devices such as pulse oximeters, glucose sensors, electrocardiograms, capnometers, fetal monitors, electromyograms, electroencephalograms, and ultrasounds are sensitive to noise and artifacts. Typical sources of noise and artifacts include baseline wander, electrode-motion artifacts, physiological artifacts, high-frequency noise, and external interference. Some artifacts can resemble real processes, such as ectopic beats, and cannot be removed reliably by simple filters; however, these are removable by the techniques taught herein.
[0012] Patents related to the current invention are summarized herein.
[0013] Mechanical Systems
[0014] Several reports of diagnostics and prognostics applied to mechanical systems have been reported.
[0015] Vibrational Analysis
[0016] R. Klein "Method and System for Diagnostics and Prognostics of a Mechanical System", U.S. Pat. No. 7,027,953 B2 (Apr. 11, 2006) describes a vibrational analysis system for diagnosis of health of a mechanical system by reference to vibration signature data from multiple domains, which aggregates several features applicable to a desired fault for trend analysis of the health of the mechanical system.
[0017] Intelligent System
[0018] S. Patel, et.al. "Process and System for Developing Predictive Diagnostic Algorithms in a Machine", U.S. Pat. No. 6,405,108 B1 (Jun. 11, 2002) describe a process for developing an algorithm for predicting failures in a system, such as a locomotive, comprising conducting a failure mode analysis to identify a subsystem, collecting expert data on the

subsystem, and generating a predicting signal for identifying failure modes, where the system uses external variables that affect the predictive accuracy of the system.

[0019] C. Bjornson, "Apparatus and Method for Monitoring and Maintaining Plant Equipment", U.S. Pat. No. 6,505,145 B1 (Jan. 11, 2003) describes a computer system that implements a process for gathering, synthesizing, and analyzing data related to a pump and/or a seal, in which data are gathered, the data is synthesized and analyzed, a root cause is determined, and the system suggests a corrective action.

[0020] C. Bjornson, "Apparatus and Method for Monitoring and Maintaining Plant Equipment", U.S. Pat. No. 6,728,660 B2 (Apr. 27, 2004) describes a computer system that implements a process for gathering, synthesizing, and analyzing data related to a pump and/or a seal, in which data are gathered, the data is synthesized and analyzed, and a root cause is determined to allow a non-specialist to properly identify and diagnose a failure associated with a mechanical seal and pump.

[0021] K. Pattipatti, et.al. "Intelligent Model-Based Diagnostics for System Monitoring, Diagnosis and Maintenance", U.S. Pat. No. 7,536,277 B2 (May 19, 2009) and K. Pattipatti, et.al. "Intelligent Model-Based Diagnostics for System Monitoring, Diagnosis and Maintenance", U.S. Pat. No. 7,260,501 B2 (Aug. 21, 2007) both describe systems and methods for monitoring, diagnosing, and for condition-based maintenance of a mechanical system, where model-based diagnostic methodologies combine or integrate analytical models and graph-based dependency models to enhance diagnostic performance.

[0022] Inferred Data

[0023] R. Tryon, et.al. "Method and Apparatus for Predicting Failure in a System", U.S. Pat. No. 7,006,947 B2 (Feb. 28, 2006) describe a method and apparatus for predicting system failure or reliability using a computer implemented model relying on probabilistic analysis, where the model uses data obtained from references and data inferred from acquired data. More specifically, the method and apparatus uses a pre-selected probabilistic model operating on a specific load to the system while the system is under operation.

[0024] Virtual Prototyping

[0025] R. Tryon, et.al. "Method and Apparatus for Predicting Failure of a Component", U.S. Pat. No. 7,016,825 B1 (Mar. 21, 2006) describe a method and apparatus for predicting component failure using a probabilistic model of a material's microstructural-based response to fatigue using virtual prototyping, where the virtual prototyping simulates grain size, grain orientation, and micro-applied stress in fatigue of the component.

[0026] R. Tryon, et.al. "Method and Apparatus for Predicting Failure of a Component, and for Determining a Grain Orientation Factor for a Material", U.S. Pat. No. 7,480,601 B2 (Jan. 20, 2009) describe a method and apparatus for predicting component failure using a probabilistic model of a material's microstructural-based response to fatigue using a computer simulation of multiple incarnations of real material behavior or virtual prototyping.

[0027] Medical Systems

[0028] Several reports of systems applied to biomedical systems have been reported.

[0029] Lung Volume

[0030] M. Sackner, et.al. "Systems and Methods for Respiratory Event Detection", U.S. patent application no. 2008/0082018 A1 (Apr. 3, 2008) describe a system and method of

processing respiratory signals from inductive plethysmographic sensors in an ambulatory setting that filters for artifact rejection to improve calibration of sensor data and to produce output indicative of lung volume.

[0031] Pulse Oximeter

[0032] J. Scharf, et.al. "Separating Motion from Cardiac Signals Using Second Order Derivative of the Photo-Plethysmograph and Fast Fourier Transforms", U.S. Pat. No. 7,020,507 B2 (Mar. 28, 2006) describes the use of filtering photo-plethysmograph data in the time domain to remove motion artifacts.

[0033] M. Diab, et.al. "Plethysmograph Pulse Recognition Processor", U.S. Pat. No. 6,463,311 B1 (Oct. 8, 2002) describe an intelligent, rule-based processor for recognition of individual pulses in a pulse oximeter-derived photo-plethysmograph waveform operating using a first phase to detect candidate pulses and a second phase applying a plethysmograph model to the candidate pulses resulting in period and signal strength of each pulse along with pulse density.

[0034] C. Baker, et.al. "Method and Apparatus for Estimating Physiological Parameters Using Model-Based Adaptive Filtering", U.S. Pat. No. 5,853,364 (Dec. 29, 1998) describe a method and apparatus for processing pulse oximeter data taking into account physical limitations using mathematical models to estimate physiological parameters.

[0035] Cardiac

[0036] J. McNames, et.al. "Method, System, and Apparatus for Cardiovascular Signal Analysis, Modeling, and Monitoring", U.S. patent application publication no. 2009/0069647 A1 (Mar. 12, 2009) describe a method and apparatus to monitor arterial blood pressure, pulse oximetry, and intracranial pressure to yield heart rate, respiratory rate, and pulse pressure variation using a statistical state-space model of cardiovascular signals and a generalized Kalman filter to simultaneously estimate and track the cardiovascular parameters of interest.

[0037] M. Sackner, et.al. "Method and System for Extracting Cardiac Parameters from Plethysmograph Signals", U.S. patent application publication no. 2008/0027341 A1 (Jan. 31, 2008) describe a method and system for extracting cardiac parameters from ambulatory plethysmographic signal to determine ventricular wall motion.

[0038] Hemorrhage

[0039] P. Cox, et.al. "Methods and Systems for Non-Invasive Internal Hemorrhage Detection", International Publication no. WO 2008/055173 A2 (May 8, 2008) describe a method and system for detecting internal hemorrhaging using a probabilistic network operating on data from an electrocardiogram, a photoplethysmogram, and oxygen, respiratory, skin temperature, and blood pressure measurements to determine if the person has internal hemorrhaging.

[0040] Disease Detection

[0041] V. Karlov, et.al. "Diagnosing Inapparent Diseases From Common Clinical Tests Using Bayesian Analysis", U.S. patent application publication no. 2009/0024332 A1 (Jan. 22, 2009) describe a system and method of diagnosing or screening for diseases using a Bayesian probability estimation technique on a database of clinical data.

[0042] Statement of the Problem

[0043] The influence of multiple sources of contaminating signals often overlaps the frequency of the signal of interest, making it difficult, if not impossible, to apply conventional filtering. Severe artifacts such as occasional signal dropouts

due to sensor movement or large periodic artifacts are also difficult to filter in real time. Biological sensor hardware can be equipped with a computer comprising software for post-processing data and reducing or rejecting noise and artifacts. Current filtering techniques typically use some knowledge of the expected frequencies of interest where the sought-after physiological information should be found, and do not contain a mathematical model describing either the physiological processes that are measured or the physical processes that measure the signal.

[0044] Adaptive filtering has been used to attenuate artifacts in pulse oximeter signals corrupted with overlapping frequency noise bands by estimating the magnitude of noise caused by patient motion and other artifacts, and canceling its contribution from pulse oximeter signals during patient movement. Such a time correlation method relies on a series of assumptions and approximations to the expected signal, noise, and artifact spectra, which compromises accuracy, reliability, and general applicability.

[0045] Biomedical filtering techniques based on Kalman and extended Kalman techniques offer advantages over conventional methods and work well for filtering linear systems or systems with small nonlinearities and Gaussian noise. These filters, however, are not adequate for filtering highly nonlinear systems and non-Gaussian/non-stationary noise. Therefore, obtaining reliable biomedical signals continue to present problems, particularly when measurements are made in mobile, ambulatory, and physically active patients.

[0046] Existing data processing techniques, including adaptive noise cancellation filters, are unable to extract information that is hidden or embedded in biomedical signals and also discard some potentially valuable information.

[0047] Existing medical sensors sense a narrow spectrum of medical parameters and states. What is needed is a system readily expanding the number of biomedical states determined.

[0048] A method or apparatus for extracting additional useful information from a biomedical system, component, or sub-component is needed to provide users and/or health care providers additional and/or clearer biomedical information.

SUMMARY OF THE INVENTION

[0049] The invention comprises use of a probabilistic model to extract and/or estimate physiological information from a biomedical sensor.

DESCRIPTION OF THE FIGURES

[0050] A more complete understanding of the present invention is derived by referring to the detailed description and claims when considered in connection with the Figures, wherein like reference numbers refer to similar items throughout the Figures.

[0051] FIG. 1 illustrates operation of an intelligent data extraction algorithm on a biomedical apparatus;

[0052] FIG. 2 provides a block diagram of a data processor;

[0053] FIG. 3 is a flow diagram of a probabilistic digital signal processor;

[0054] FIG. 4 illustrates a dual estimator;

[0055] FIG. 5 expands the dual estimator;

[0056] FIG. 6 illustrates state and model parameter estimators;

[0057] FIG. 7 provides inputs and internal operation of a dynamic state-space model;

[0058] FIG. 8 is a flow chart showing the components of a hemodynamics dynamic state-space model;

[0059] FIG. 9 is a chart showing input sensor data, FIG. 9A; processed output data of heart rate, FIG. 9B; stroke volume, FIG. 9C; cardiac output, FIG. 9D; oxygen, FIG. 9E; and pressure, FIG. 9F from a data processor configured to process pulse oximetry data;

[0060] FIG. 10 is a chart showing input sensor data, FIG. 10A, and processed output data, FIGS. 10A-10E, from a data processor configured to process pulse oximetry data under a low blood perfusion condition;

[0061] FIG. 11 is a flow chart showing the components of an electrocardiograph dynamic state-space model;

[0062] FIG. 12 is a chart showing noisy non-stationary ECG sensor data input, FIG. 12A and FIG. 12B and processed heart rate and ECG output, FIG. 12A and FIG. 12B, for a data processor configured to process ECG sensor data;

[0063] FIG. 13A and FIG. 13B are charts showing input ECG sensor data and comparing output data from a data processor according to the present invention with output data generating using a Savitzky-Golay FIR data processing algorithm; and

[0064] FIG. 14 provides a flowchart of dynamic state-space model diagnostics used as prognosis and control.

DETAILED DESCRIPTION OF THE INVENTION

[0065] The invention comprises use of a method, a system, and/or an apparatus using a probabilistic model for monitoring and/or estimating a physiological or medical parameter using a biomedical apparatus.

[0066] In one embodiment, an intelligent data extraction algorithm (IDEA) is used in a system, which combines a dynamic state-space model with a probabilistic digital signal processor to estimate a parameter, such as a biomedical parameter. Initial probability distribution functions are input to a dynamic state-space model, which iteratively operates on probability distribution functions, such as state and model probability distribution functions, to generate a prior probability distribution function, which is input to a probabilistic updater. The probabilistic updater integrates sensor data with the prior probability distribution function to generate a posterior probability distribution function passed to a probabilistic sampler, which estimates one or more parameters using the posterior, which is output or re-sampled and used as an input to the dynamic state-space model in the iterative algorithm. In various embodiments, the probabilistic data signal processor is used to filter output and/or estimate a value of a new physiological parameter from a biomedical device using appropriate physical models, which optionally include biomedical, chemical, electrical, optical, mechanical, and/or fluid based models. For clarity, examples of heart and cardiovascular medical devices are provided.

[0067] In various embodiments, the probabilistic digital signal processor comprises one or more of a dynamic state-space model, a dual or joint updater, and/or a probabilistic sampler, which process input data, such as sensor data and generates an output. Preferably, the probabilistic digital signal processor (1) iteratively processes the data and/or (2) uses a physical model in processing the input data.

[0068] The probabilistic digital signal processor optionally:

[0069] operates using data from a medical meter, where the medical meter yields a first physical parameter from

raw data, to generate a second physical parameter not output by the medical meter;

[0070] operates on discrete/non-probabilistic input data from a medical device to generate a probabilistic output function;

[0071] iteratively circulates a probability distribution function through at least two of the dynamic state-space model, the dual or joint updater, and/or the probabilistic sampler;

[0072] fuses or combines output from multiple medical devices; and

[0073] prognosticates probability of future events.

[0074] To facilitate description of the probabilistic digital signal processor, a non-limiting example of a hemodynamics process model is provided. In this example, the probabilistic digital signal processor is provided:

[0075] raw sensor data, such as current, voltage, and/or resistance; and/or

[0076] output from a medical device to a first physical parameter.

[0077] In this example, the medical device is a pulse oximeter and the first physical parameter from the pulse oximeter provided as input to the probabilistic digital signal processor is one or more of:

[0078] raw data;

[0079] heart rate; and/or

[0080] blood oxygen saturation.

[0081] The probabilistic digital signal processor uses a physical model, such as a probabilistic model, to operate on the first physical parameter to generate a second physical parameter, where the second physical parameter is not the first physical parameter. For example, the output of the probabilistic digital signal processor when provided with the pulse oximeter data is one or more of:

[0082] a heart stroke volume;

[0083] a cardiac output flow rate;

[0084] an aortic blood pressure; and/or

[0085] a radial blood pressure.

[0086] Optionally, the output from the probabilistic model is an updated, error filtered, and/or smoothed version of the original input data, such as a smoothed blood oxygen saturation percentage as a function of time.

[0087] Deterministic vs. Probabilistic Models

[0088] Typically, computer-based systems use a mapping between observed symptoms of failure and the equipment where the mapping is built using deterministic techniques. The mapping typically takes the form of a look-up table, a symptom-problem matrix, trend analysis, and production rules. In stark contrast, alternatively probabilistic models are used to analyze a system. An example of a probabilistic model, referred to herein as an intelligent data extraction system is provided, infra.

[0089] Intelligent Data Extraction System

[0090] Referring now to FIG. 1, an algorithm based intelligent data extraction system 100 is illustrated. The intelligent data extraction system 100 uses a controller 110 to control a sensor 120. In one embodiment, the controller 110 comprises a microprocessor in a computer or computer system, an embedded processor, and/or an embedded device. The sensor 120 is used to measure a parameter and/or is incorporated into a biomedical apparatus 130. Optionally, the controller 110 additionally controls the medical apparatus and/or is built into the biomedical apparatus 130. The sensor 120 provides readings to a data processor or a probabilistic digital signal

processor 200, which provides feedback to the controller 110 and/or provides output 150. In one embodiment, the controller 110 comprises a microprocessor in a computer or computer system.

[0091] Herein, to enhance understanding and for clarity of presentation, non-limiting examples of an intelligent data extraction system operating on a hemodynamics biomedical devices are used to illustrate methods, systems, and apparatus described herein. Generally, the methods, systems, and apparatus described herein extend to any apparatus having a moveable part and/or to any medical device. Examples of the dynamic state-space model with a probabilistic digital signal processor used to estimate parameters of additional biomedical systems are provided after the details of the processing engine are presented.

[0092] Still referring to FIG. 1, in a pulse oximeter example the controller 110 controls a sensor 120 in the pulse oximeter apparatus 130. The sensor 120 provides readings, such as a spectral reading to the probabilistic digital signal processor 200, which is preferably a probability based data processor. The probabilistic digital signal processor 200 optionally operates on the input data or provides feedback to the controller 110, such as state of the patient, as part of a loop, iterative loop, time series analysis, and/or generates the output 150, such as a smoothed biomedical state parameter or a new biomedical state parameter. For clarity, the pulse oximeter apparatus is used repetitively herein as an example of the biomedical apparatus 130 upon which the intelligent data extraction system 100 operates. The probabilistic digital signal processor 200 is further described, *infra*.

[0093] Data Processor

[0094] Referring now to FIG. 2, the probabilistic digital signal processor 200 of the intelligent data extraction system 100 is further described. Generally, the data processor includes a dynamic state-space model 210 (DSSM) and a probabilistic updater 220 that iteratively or sequentially operate on sensor data 122 from the sensor 120. The probabilistic updater 220 outputs a probability distribution function (PDF) to a parameter updater or a probabilistic sampler 230, which generates one or more parameters, such as an estimated diagnostic parameter, which is sent to the controller 110, is used as part of an iterative loop as input to the dynamic state-space model 210, and/or is a basis of the output 150. The dynamic state-space model 210 and probabilistic updater 220 are further described, *infra*.

[0095] Referring now to FIG. 3, the probabilistic digital signal processor 200 is further described. Generally, initial probability distribution functions 310 are input to the dynamic state-space model 210. In a process 212, the dynamic state-space model 210 operates on the initial probability distribution functions 310 to generate a prior probability distribution function, hereinafter also referred to as a prior or as a prior PDF. For example, an initial state parameter 312 probability distribution function and an initial model parameter 314 probability distribution function are provided as initial inputs to the dynamic state-space model 210. The dynamic state-space model 210 operates on the initial state parameter 312 and/or initial model parameter 314 to generate the prior probability distribution function, which is input to the probabilistic updater 220. In a process 320, the probabilistic updater 220 integrates sensor data, such as timed sensor data 122, by operating on it and on the prior probabilistic distribution function to generate a posterior probability distribution function, herein also referred to as a posterior or as

a posterior PDF. In a process 232, the probabilistic sampler 230 estimates one or more parameters using the posterior probability distribution function. The probabilistic sampler 230 operates on the state and model parameter probability distribution functions from the state and model parameter updaters 224, 226, respectively or alternatively operates on the joint parameter probability distribution function and calculates an output. The output is optionally:

[0096] the state or joint parameter PDF, passed to the PDF resampler 520; and/or

[0097] output values resulting from an operation on the inputs to the output 150 or output display or the 110 controller

[0098] In one example, expectation values such as mean and standard deviation of a state parameter are calculated from the state parameter PDF and output to the user, such as for diagnosis. In another example, expectation values, such as the mean value of state and model parameters, are calculated and then used in a model to output a more advanced diagnostic or prognostic parameter. In a third example, expectation values are calculated on a PDF that is the result of an operation on the state parameter PDF and/or model parameter PDF. Optionally, the output is the same as the state parameter PDF or model parameter PDF. Other data, such as user-input data, is optionally used in the output operation. The estimated parameters of the probabilistic sampler 230 are optionally used as a feedback to the dynamic state-space model 210 or are used to estimate a biomedical parameter. The feedback to the dynamic state-space model 210 is also referred to as a new probability function or as a new PDF, which is/are updates of the initial state parameter 312 and/or are updates of the initial model parameter 314. Again, for clarity, an example of an estimated parameter 232 is a measurement of the heart/cardiovascular system, such as heartbeat stroke volume.

[0099] Dual Estimator

[0100] In another embodiment, the probabilistic updater 220 of the probabilistic digital signal processor 200 uses a dual or joint estimator 222. Referring now to FIG. 4, the joint estimator 222 or dual estimation process uses both a state parameter updater 224 and a model parameter updater 226. Herein, for clarity, a dual estimator 222 is described. However, the techniques and steps described herein for the dual estimator are additionally applicable to a joint estimator as the state parameter and model parameter vector and/or matrix of the dual estimator are merely concatenated in a joint parameter vector and/or are joined in a matrix in a joint estimator.

[0101] State Parameter Updater

[0102] A first computational model used in the probabilistic updater 220 includes one or more state variables or state parameters, which correspond to the parameter being estimated by the state parameter updater 224. In the case of the hemodynamics monitoring apparatus, state parameters include time, intensity, reflectance, and/or a pressure. Some or all state parameters are optionally chosen such that they represent the 'true' value of noisy timed sensor data. In this case, calculation of such a posterior state parameter PDF constitutes a noise filtering process and expectation values of the PDF optionally represent filtered sensor values and associated confidence intervals.

[0103] Model Parameter Updater

[0104] A second computational model used in the probabilistic updater 220 includes one or more model parameters updated in the model parameter updater 226. For example, in

the case of the hemodynamics monitoring apparatus, model parameters include time interval, a heart rate, a stroke volume, and/or a blood oxygenation percentage.

[0105] Hence, the dual estimator 222 optionally simultaneously or in an iterative loop updates or calculates one or both of the state parameters and model parameters. The probabilistic sampler 230 is used to determine the estimated value for the biomedical parameter, which is optionally calculated from a state parameter, a model parameter, or a combination of one or more of the state parameter and/or model parameter.

[0106] Referring still to FIGS. 3 and 4 and now referring to FIG. 5, a first example of the dual estimator 222 is described and placed into context of the dynamic state-space model 210 and probabilistic sampler 230 of the probabilistic digital signal processor 200. The state parameter updater 224 element of the dual estimator 222 optionally:

[0107] uses a sensor data integrator 320 operating on the prior PDF being passed from the dynamic state-space model 210, and optionally operates on new timed sensor data 122, to produce the posterior PDF passed to the probabilistic sampler 230;

[0108] operates on current model parameters 510; and/or

[0109] in a process 520, the state parameter updater 224 optionally re-samples a probability distribution function passed from the probabilistic sampler 230 to form the new probability distribution function passed to the dynamic state-space model 210.

[0110] In addition, in a process 530 the model parameter updater 226 optionally integrates new timed sensor data 122 with output from the probabilistic sampler 230 to form new input to the dynamic state-space model 210.

[0111] Referring now to FIG. 6, a second example of a dual estimator 222 is described. In this example:

[0112] initial state parameter probability distribution functions 312 are passed to the dynamic state-space model 210; and/or

[0113] initial model parameter probability distribution functions 314 are passed to the dynamic state-space model 210;

[0114] Further, in this example:

[0115] a Bayesian rule applicator 322 is used as an algorithm in the sensor data integrator 320;

[0116] a posterior distribution sample algorithm 522 is used as the algorithm in the resampling of the PDF process 520; and

[0117] a supervised or unsupervised machine learning algorithm 532 is used as the algorithm in the model parameter updater 530.

[0118] Filtering

[0119] In various embodiments, algorithms, data handling steps, and/or numerical recipes are used in a number of the steps and/or processes herein. The inventor has determined that several algorithms are particularly useful: sigma point Kalman filtering, sequential Monte Carlo, and/or use of a sampler. In a first example, either the sigma point Kalman filtering or sequential Monte Carlo algorithms are used in generating the probability distribution function. In a second example, either the sigma point Kalman filtering or sequential Monte Carlo algorithms are used in the unsupervised machine learning 532 step in the model parameter updater 530 to form an updated model parameter. The sigma point Kalman filtering, sequential Monte Carlo algorithms, and use of a sampler are further described, infra.

[0120] Sigma Point Kalman Filter

[0121] Filtering techniques based on Kalman and extended Kalman techniques offer advantages over conventional methods and work well for filtering linear systems or systems with small nonlinearities and Gaussian noise. These Kalman filters, however, are not optimum for filtering highly nonlinear systems and/or non-Gaussian/non-stationary noise. In stark contrast, sigma point Kalman filters are well suited to data having nonlinearities and non-Gaussian noise.

[0122] Herein, a sigma point Kalman filter (SPKF) refers to a filter using a set of weighted sigma-points that are deterministically calculated, such as by using the mean and square-root decomposition, or an equivalent, of the covariance matrix of a probability distribution function to about capture or completely capture at least the first and second order moments. The sigma-points are subsequently propagated in time through the dynamic state-space model 210 to generate a prior sigma-point set. Then, prior statistics are calculated using tractable functions of the propagated sigma-points and weights, and new measurements.

[0123] Sigma point Kalman filter advantages and disadvantages are described herein. A sigma point Kalman filter interprets a noisy measurement in the context of a mathematical model describing the system and measurement dynamics. This gives the sigma point Kalman filter inherent superior performance to all 'model-less' methods, such as Wiener filtering, wavelet de-noising, principal component analysis, independent component analysis, nonlinear projective filtering, clustering methods, adaptive noise cancelling, and many others.

[0124] A sigma point Kalman filter is superior to the basic Kalman filter, extended Kalman filter, and related variants of the Kalman filters. The extended Kalman filter propagates the random variable using a single measure, usually the mean, and a first order Taylor expansion of the nonlinear dynamic state-space model 210. Conversely, a sigma point Kalman filter decomposes the random variable into distribution moments and propagates those using the unmodified nonlinear dynamic state-space model 210. As a result, the sigma point Kalman filter yields higher accuracy with equal algorithm complexity, while also being easier to implement in practice.

[0125] In the sigma-point formalism the probability distribution function is represented by a set of values called sigma points, those values represent the mean and other moments of the distribution which, when input into a given function, recovers the probability distribution function.

[0126] Sequential Monte Carlo

[0127] Sequential Monte Carlo (SMC) methods approximate the prior probability distribution function through use of a set of weighted sample values without making assumptions about its form. The samples are then propagated in time through the unmodified dynamic state-space model 210. The resulting samples are used to update the posterior via Bayes rule and the latest noisy measurement or timed sensor data 122.

[0128] In the sequential Monte Carlo formalism the PDF is actually discretized into a collection of probability "particles" each representing a segment of the probability density in the probability distribution function.

[0129] SPKF and SMC

[0130] In general, sequential Monte Carlo methods have analysis advantages compared to the sigma point Kalman filters, but are more computationally expensive. However, the

SPKF uses a sigma-point set, which is an exact representation only for Gaussian probability distribution functions (PDFs). As a result, SPKFs lose accuracy when PDFs depart heavily from the Gaussian form, such as with bimodal, heavily-tailed, or nonstationary distributions. Hence, both the SMC and SPKF filters have advantages. However, either a SMC or SPKF is used to propagate the prior using the unmodified DSSM. Herein, generally when a SMC filter is used a SPKF filter is optionally used and vice-versa.

[0131] A SPKF or SMC algorithm is used to generate a reference signal in the form of a first probability distribution from the model's current (time= t) physiological state. The reference signal probability distribution and a probability distribution generated from a measured signal from a sensor at a subsequent time (time= $t+n$) are convoluted using Bayesian statistics to estimate the true value of the measured physiological parameter at time= $t+n$. The probability distribution function is optionally discrete or continuous. The probability distribution function is optionally used to identify the probability of each value of an unidentified random variable (discrete) or the probability of the value falling within a particular interval (continuous).

[0132] In one embodiment, optionally an estimation filter operates on the prior probability distribution function, having an initial distribution, in generation of the posterior probability distribution function, where the posterior probability distribution function has a model parameter distribution that is narrower than the initial distribution.

[0133] Characteristic Samplers

[0134] Probability distribution functions (PDFs) are optionally continuous or discrete. In the continuous case the probability distribution function is represented by a function. In the discrete case, the variable space is binned into a series of discrete values. In both the continuous and discrete cases, probability distribution functions are generated by first decomposing the PDF into a set of samplers that are characteristic of the probability distribution function and then propagating those samplers via computations through the DSSM (prior generation) and sensor data integrator (posterior generation). Herein, a sampler is a combination of a value and label. The value is associated with the x-axis of the probability distribution function, which denotes state, model, or joint parameters. The label is associated with the y-axis of the probability distribution function, which denotes the probability. Examples of labels are: weight, frequency, or any arbitrary moment of a given distribution, such as a first Gaussian moment. A powerful example of characteristic sampler use is decomposing the PDF into a series of state values with attached first Gaussian moment labels. This sum of several Gaussian distributions with different values and moments usually gives accurate approximations of the true probability distribution function.

[0135] Probabilistic Digital Signal Processor

[0136] As described, supra, in various embodiments, the probabilistic digital signal processor **200** comprises one or more of a dynamic state-space model **210**, a dual or joint estimator **222**, and/or a probabilistic sampler **230**, which processes input data, such as sensor data **122** and generates an output **150**. Preferably, the probabilistic digital signal processor **200** (1) iteratively processes the data and/or (2) uses a physical model in processing the input data.

[0137] The probabilistic digital signal processor **200** optionally:

[0138] operates using data from a medical meter, where the medical meter yields a first physical parameter from raw data, to generate a second physical parameter not output by the medical meter;

[0139] operates on discrete/non-probabilistic input data from a medical device to generate a probabilistic output function;

[0140] iteratively circulates a probability distribution function through at least two of the dynamic state-space model, the dual or joint updater, and/or the probabilistic sampler;

[0141] fuses or combines output from multiple medical devices; and

[0142] prognosticates probability of future events.

[0143] A hemodynamics example of a probabilistic digital signal processor **200** operating on data from a pulse oximeter is used to describe these processes, infra.

[0144] Dynamic State-Space Model

[0145] The dynamic state-space model **210** is further described herein.

[0146] Referring now to FIG. 7, schematics of an exemplary dynamic state-space model **210** (DSSM) used in the processing of data is provided. The dynamic state-space model **210** typically and optionally includes a process model **710** and/or an observation model **720**. The process model **710**, F, which mathematically represents mechanical processes involved in generating one or more biomedical parameters, is measured by a sensor and/or a sensor sensing a mechanical element and describes the state of the biomedical apparatus, output of the biomedical apparatus, and/or state of the patient over time in terms of state parameters. This mathematical model optimally includes mathematical representations accounting for process noise **750**, such as mechanically caused artifacts that may cause the sensor to produce a digital output that does not produce an accurate measurement for the biomedical parameter being sensed. The dynamic state-space model **210** also comprises an observational model **720**, H, which mathematically represents processes involved in collecting sensor data measured by the mechanical sensor. This mathematical model optimally includes mathematical representations accounting for observation noise produced by the sensor apparatus that may cause the sensor to produce a digital output that does not produce an accurate measurement for a biomedical parameter being sensed. Noise terms in the mathematical models are not required to be additive.

[0147] While the process and observational mathematical models **710**, **720** are optionally conceptualized as separate models, they are preferably integrated into a single mathematical model that describes processes that produce a biomedical parameter and processes involved in sensing the biomedical parameter. The integrated process and observation model, in turn, is integrated with a processing engine within an executable program stored in a data processor, which is configured to receive digital data from one or more sensors and to output data to a display and/or another output format.

[0148] Still referring to FIG. 7, inputs into the dynamic state-space model **210** include one or more of:

[0149] state parameters **730**, such as the initial state parameter probability distribution function **312** or the new PDF;

[0150] model parameters 740, such as the initial noise parameter probability distribution function 314 or an updated model parameter from the unsupervised machine learning module 532;

[0151] process noise 750; and/or

[0152] observation noise 760.

[0153] Hemodynamics Dynamic State-Space Model

[0154] A first non-limiting specific example is used to facilitate understanding of the dynamic state-space model 210. Referring now to FIG. 8, a hemodynamics dynamic state-space model 805 flow diagram is presented. Generally, the hemodynamics dynamic state-space model 805 is an example of a dynamic state-space model 210. The hemodynamics dynamic state-space model 805 combines sensor data 122, such as a spectral readings of skin, with a physical parameter based probabilistic model. The hemodynamics dynamic state-space model 805 operates in conjunction with the probabilistic updater 220 to form an estimate of heart/cardiovascular state parameters.

[0155] To facilitate description of the probabilistic digital signal processor, a non-limiting example of a hemodynamics process model is provided. In this example, the probabilistic digital signal processor is provided:

[0156] raw sensor data, such as current, voltage, and/or resistance; and/or

[0157] a first physical parameter output from a medical device.

[0158] In this example, the medical device is a pulse oximeter collecting raw data and the first physical parameter from the pulse oximeter provided as input to the probabilistic digital signal processor is one or more of:

[0159] a heart rate; and/or

[0160] a blood oxygen saturation.

[0161] The probabilistic digital signal processor uses a physical model, such as a probabilistic model, to operate on the first physical parameter and/or the raw data to generate a second physical parameter, where the second physical parameter is not the first physical parameter. For example, the output of the probabilistic digital signal processor using a physical hemodynamic models, when provided with the pulse oximeter data, is one or more of:

[0162] a heart stroke volume;

[0163] a cardiac output flow rate;

[0164] an aortic blood pressure; and/or

[0165] a radial blood pressure.

[0166] Optionally, the output from the probabilistic model is an updated, error filtered, and/or smoothed version of the original input data, such as a smoothed blood oxygen saturation percentage as a function of time.

[0167] Still referring to FIG. 8, to facilitate description of the hemodynamics dynamic state-space model 805, a non-limiting example is provided. In this example, the hemodynamics dynamic state-space model 805 is further described. The hemodynamics dynamic state-space model 805 preferably includes a hemodynamics process model 810 corresponding to the dynamic state space model 210 process model 710. Further, the hemodynamics dynamic state-space model 805 preferably includes a hemodynamics observation model 820 corresponding to the dynamic state space model 210 observation model 720. The hemodynamics process model 810 and hemodynamics observation model 820 are further described, infra.

[0168] Still referring to FIG. 8, the hemodynamics process model 810 optionally includes one or more of a heart model

812, a vascular model 814, and/or a light scattering or a light absorbance model 816. The heart model 812 is a physics based probabilistic model of the heart and movement of blood in and/or from the heart. The vascular model 814 is a physics based probabilistic model of movement of blood in arteries, veins, and/or capillaries. The various models optionally share information. For example, blood flow or stroke volume exiting the heart in the heart model 812 is optionally an input to the arterial blood in the vascular model 814. The light scattering and/or absorbance model 816 relates spectral information, such as from a pulse oximeter, to additional hemodynamics dynamic state-space model parameters, such as heart rate (HR), stroke volume (SV), and/or whole-blood oxygen saturation (SpO₂) or oxyhemoglobin percentage.

[0169] Still referring to FIG. 8, the hemodynamics observation model 820 optionally includes one or more of a sensor dynamics and noise model 822 and/or a spectrometer signal transduction noise model 824. Each of the sensor dynamics and noise model 822 and the spectrometer signal transduction noise model 824 are physics based probabilistic models related to noises associated with the instrumentation used to collect data, environmental influences on the collected data, and/or noise due to the human interaction with the instrumentation, such as movement of the sensor. As with the hemodynamics process model 810, the sub-models of the hemodynamics observation model 820 optionally share information. For instance, movement of the sensor noise is added to environmental noise. Optionally and preferably, the hemodynamics observation model 820 shares information with and/provides information to the hemodynamics process model 810.

[0170] The hemodynamics dynamic state-space model 805 receives inputs, such as one or more of:

[0171] hemodynamics state parameters 830;

[0172] hemodynamics model parameters 840;

[0173] hemodynamics process noise 850; and

[0174] hemodynamics observation noise 860.

[0175] Examples of hemodynamics state parameters 830, corresponding to state parameters 730, include: radial pressure (P_r), aortic pressure (P_{ao}), time (t), a spectral intensity (I) or a related absorbance value, a reflectance or reflectance ratio, such as a red reflectance (R_r) or an infrared reflectance (R_{ir}), and/or a spectral intensity ratio (I_R). Examples of hemodynamics model parameters 840, corresponding to the more generic model parameters 740, include: heart rate (HR), stroke volume (SV), and/or whole-blood oxygen saturation (SpO₂). In this example, the output of the hemodynamics dynamic state-space model 805 is a prior probability distribution function with parameters of one or more of the input hemodynamics state parameters 830 after operation on by the heart dynamics model 812, a static number, and/or a parameter not directly measured or output by the sensor data. For instance, an input data stream is optionally a pulse oximeter yielding spectral intensities, ratios of intensities, and a percent oxygen saturation. However, the output of the hemodynamics dynamic state-space model is optionally a second physiological value, such as a stroke volume of the heart, which is not measured by the input biomedical device.

[0176] The hemodynamics dynamic state-space model 805 optionally receives inputs from one or more additional models, such as an irregular sampling model, which relates information collected at irregular or non-periodic intervals to the hemodynamics dynamic state-space model 805.

[0177] Generally, the hemodynamics dynamic state-space model 805 is an example of a dynamic state-space model 210,

which operates in conjunction with the probabilistic updater **220** to form an estimate of a heart state parameter and/or a cardiovascular state parameter.

[0178] Generally, the output of the probabilistic signal processor **200** optionally includes a measure of uncertainty, such as a confidence interval, a standard deviation and/or a standard error. Optionally, the output of the probabilistic signal processor **200** includes:

[0179] a filtered or smoothed version of the parameter measured by the medical meter; and/or

[0180] a probability function associated with a parameter not directly measured by the medical meter.

EXAMPLE I

[0181] An example of a pulse oximeter with probabilistic data processing is provided as an example of the hemodynamics dynamic state-space model **805**. The model is suitable for processing data from a pulse oximeter model. In this example, particular equations are used to further describe the hemodynamics dynamic state-space model **805**, but the equations are illustrative and non-limiting in nature.

[0182] Heart Model

[0183] An example of the heart model **812** is used to further described an example of the hemodynamics dynamic state-space model **805**. In this example, cardiac output is represented by equation 1,

$$Q_{CO}(t) = \bar{Q}_{CO} \sum_{k=1}^6 a_k \exp\left[\frac{-(t-b_k)^2}{c_k^2}\right] \quad (1)$$

where cardiac output $Q_{CO}(t)$, is expressed as a function of heart rate (HR) and stroke volume (SV) and where $Q_{CO} = (HR \times SV)/60$. The values a_k , b_k , and c_k are adjusted to fit data on human cardiac output.

[0184] Vascular Model

[0185] An example of the vascular model **814** of the hemodynamics state-space model **805** is provided. The cardiac output function pumps blood into a Windkessel 3-element model of the vascular system including two state variables: aortic pressure, P_{ao} , and radial (Windkessel) pressure, P_w , according to equations 2 and 3,

$$P_{w,k+1} = \frac{1}{C_w R_p} ((R_p + Z_0) Q_{CO} - P_{CO,k}) \delta t + P_{w,k} \quad (2)$$

$$P_{ao,k+1} = P_{w,k+1} + Z_0 Q_{CO} \quad (3)$$

where R_p and Z_0 are the peripheral resistance and characteristic aortic impedance, respectively. The sum of these two terms is the total peripheral resistance due to viscous (Poiseuille-like) dissipation according to equation 4,

$$Z_0 = \sqrt{\rho / AC_l} \quad (4)$$

where ρ is blood density and C_l is the compliance per unit length of artery. The elastic component due to vessel compliance is a nonlinear function including thoracic aortic cross-sectional area, A : according to equation 5,

$$A(P_{CO}) = A_{max} \left[\frac{1}{2} + \frac{1}{\pi} \arctan\left(\frac{P_{CO} - P_0}{P_1}\right) \right] \quad (5)$$

where A_{max} , P_0 , and P_1 are fitting constants correlated with age and gender according to equations 6-8.

$$A_{max} = (5.62 - 1.5(\text{gender})) \cdot \text{cm}^2 \quad (6)$$

$$P_0 = (76 - 4(\text{gender}) - 0.89(\text{age})) \cdot \text{mmHg} \quad (7)$$

$$P_1 = (57 - 0.44(\text{age})) \cdot \text{mmHg} \quad (8)$$

[0186] The time-varying Windkessel compliance, C_w , and the aortic compliance per unit length, C_p , are related in equation 9,

$$C_w = l C_1 = l \frac{dA}{dP_\infty} = l \frac{A_{max} l (\pi P_1)}{1 + \left(\frac{P_\infty - P_0}{P_1}\right)^2} \quad (9)$$

[0187] where l is the aortic effective length. The peripheral resistance is defined as the ratio of average pressure to average flow. A set-point pressure, P_{set} , and the instantaneous flow are related to the peripheral resistance, R_p , according to equation 10,

$$R_p = \frac{P_{set}}{(HR \cdot SV)/60} \quad (10)$$

are used to provide compensation to autonomic nervous system responses. The value for P_{set} is optionally adjusted manually to obtain 120 over 75 mmHg for a healthy individual at rest.

[0188] Light Scattering and Absorbance Model

[0189] The light scattering and absorbance model **816** of the hemodynamics dynamic state-space model **805** is further described. The compliance of blood vessels changes the interactions between light and tissues with pulse. This is accounted for using a homogenous photon diffusion theory for a reflectance or transmittance pulse oximeter configuration according to equation 11,

$$R = \frac{I_{ac}}{I_{dc}} = \frac{\Delta I}{I} = \frac{3}{2} \sum_s^1 K(\alpha, d, r) \sum_a^{art} \Delta V_0 \quad (11)$$

for each wavelength. In this example, the red and infrared bands are centered at about 660 ± 100 nm and at about 880 ± 100 nm. In equation 11, I (no subscript) denotes the detected intensity, R , is the reflected light, and the, I_{ac} , is the pulsating or ac intensity or signal, I_{dc} , is the background or dc intensity, α , is the attenuation coefficient, d , is the illumination length scale or depth of photon penetration into the skin, and, r , is the distance between the source and detector.

[0190] Referring again to the vascular model **814**, V_a is the arterial blood volume, which changes as the cross-sectional

area of illuminated blood vessels, ΔA_w , according to equation 12,

$$\Delta V_{\alpha} \approx r \cdot \Delta A_w \quad (12)$$

where r is the source-detector distance.

[0191] Referring again to the light scattering and absorbance model **816**, the tissue scattering coefficient, $\Sigma'_{s,s}$, is assumed constant but the arterial absorption coefficient, $\Sigma'_{a,art}$, which represents the extinction coefficients, depends on blood oxygen saturation, SpO_2 , according to equation 13,

$$\sum_a^{art} = \frac{H}{v_i} [SpO_2 \cdot \sigma_0^{100\%} + (1 - SpO_2) \cdot \sigma_0^{0\%}] \quad (13)$$

which is the Beer-Lambert absorption coefficient, with hematocrit, H , and red blood cell volume, v_i . The optical absorption cross-sections, proportional to the absorption coefficients, for red blood cells containing totally oxygenated (HbO_2) and totally deoxygenated (Hb) hemoglobin are $\sigma_a^{100\%}$ and $\sigma_a^{0\%}$, respectively.

[0192] The function $K(\alpha, d, r)$, along with the scattering coefficient, the wavelength, sensor geometry, and oxygen saturation dependencies, alters the effective optical path-lengths, according to equation 14.

$$K(\alpha, d, r) \approx \frac{-r^2}{1 + \alpha r} \quad (14)$$

[0193] The attenuation coefficient α is provided by equation 15,

$$\alpha = \sqrt{3\Sigma_a(\Sigma_s + \Sigma_a)} \quad (15)$$

where Σ_a and Σ_s are whole-tissue absorption and scattering coefficients, respectively, which are calculated from Mie Theory.

[0194] Red, $\overline{K_r}$, and infrared, $\overline{K_{ir}}$, K values as a function of SpO_2 are optionally represented by two linear fits, provided in equations 16 and 17

$$\overline{K_r} \approx -4.03 \cdot SpO_2 - 1.17 \quad (16)$$

$$\overline{K_{ir}} \approx 0.102 \cdot SpO_2 - 0.753 \quad (17)$$

in mm^2 . The overbar denotes the linear fit of the original function. Referring yet again to the vascular model **814**, the pulsatile behavior of ΔA_w , which couples optical detection with the cardiovascular system model, is provided by equation 18,

$$\Delta A_w = \frac{A_{w,max}}{\pi} \frac{P_{w,1}}{P_{w,1}^2 + (P_{w,k+1} - P_{w,0})^2} \Delta P_w \quad (18)$$

with $P_{w,0} = (1/3)P_0$ and $P_{w,1} = (1/3)P_1$ to account for the poorer compliance of arterioles and capillaries relative to the thoracic aorta. The subscript k is a data index and the subscript $k+1$ or $k+n$ refers to the next or future data point.

[0195] Referring yet again to the light scattering and absorbance models, third and fourth state variables, the red and infrared reflected intensity ratios, $R = I_{\alpha c} / I_{dc}$, are provided by equations 19 and 20.

$$R_{r,k+1} = c \Sigma'_{s,s} \overline{K_r} \Sigma'_{a,art} \Delta A_w + R_{r,k} + v_r \quad (19)$$

$$R_{ir,k+1} = c \Sigma'_{s,s} \overline{K_{ir}} \Sigma'_{a,art} \Delta A_w + R_{ir,k} + v_{ir} \quad (20)$$

[0196] Here, v is a process noise, such as an added random number or are Gaussian-distributed process noises intended to capture the baseline wander of the two channels, $\Sigma'_{s,s}$ and $\Sigma'_{a,art}$ are scattering coefficients, and $\Sigma'_{a,art}$ and $\Sigma'_{a,ir}$ are absorption coefficients.

[0197] Sensor Dynamics and Noise Model

[0198] The sensor dynamics and noise model **822** is further described. The constant c subsumes all factors common to both wavelengths and is treated as a calibration constant. The observation model adds noises, n , with any probability distribution function to R_r and R_{ir} , according to equation 21.

$$\begin{bmatrix} y_{r,k} \\ y_{ir,k} \end{bmatrix} = \begin{bmatrix} R_{r,k} \\ R_{ir,k} \end{bmatrix} + \begin{bmatrix} n_{r,k} \\ n_{ir,k} \end{bmatrix} \quad (21)$$

[0199] A calibration constant, c , was used to match the variance of the real $I_{\alpha c} / I_{dc}$ signal with the variance of the dynamic state-space model generated signal for each wavelength. After calibration, the age and gender of the patient was entered. Estimates for the means and covariances of both state and parameter PDFs are optionally entered.

[0200] Referring now to FIG. 9, processed data from a relatively high signal-to-noise ratio pulse oximeter data source is provided for a fifteen second stretch of data. Referring now to FIG. 9A, input photoplethysmographic waveforms are provided. Using the hemodynamics dynamic state-space model **805**, the input waveforms were used to extract heart rate (FIG. 9B), left-ventricular stroke volume (FIG. 9C), cardiac output (FIG. 9D), blood oxygen saturation (FIG. 9E), and aortic and systemic (radial) pressure waveforms (FIG. 9F). Several notable points are provided. First, the pulse oximeter provided a first physical value of a hemoglobin oxygen saturation percentage. However, the output blood oxygen saturation percentage, FIG. 9E, was processed by the probabilistic digital signal processor **200**. Due to the use of the sensor dynamics and noise model **822** and the spectrometer signal transduction noise model, noisy data, such as due to ambulatory movement of the patient, is removed in the smoothed and filtered output blood oxygen saturation percentage. Second, some pulse oximeters provide a heart rate. However, in this case the heart rate output was calculated using the physical probabilistic digital signal processor **200** in the absence of a heart rate input data source **122**. Third, each of the stroke volume, FIG. 9C, cardiac output flow rate, FIG. 9D, aortic blood pressure, FIG. 9E, and radial blood pressure, FIG. 9E, are second physical parameters that are different from the first physical parameter measured by the pulse oximeter photoplethysmographic waveforms.

[0201] Referring now to FIG. 10, a second stretch of photoplethysmographic waveforms are provided that represent a low signal-to-noise ratio signal from a pulse oximeter. Low signal-to-noise photoplethysmographic waveforms (FIG. 10A) were used to extract heart rate (FIG. 10B), left-ventricular stroke volume (FIG. 10C), blood oxygen saturation (FIG. 10D), and aortic and systemic (radial) pressure waveforms (FIG. 10E) using the hemodynamics dynamic state-space model **805**. In each case, the use of the probabilistic digital signal processor **200** configured with the optional sensor dynamics and noise model **822** and spectrometer signal trans-

duction model **824** overcame the noisy input stream to yield smooth and functional output data for medical use.

EXAMPLE II

[0202] A second example of a dynamic state-space model **210** coupled with a dual or joint estimator **222** and/or a probabilistic sampler **230** in a probabilistic updater **220** in a medical or biomedical application is provided.

[0203] Electrocardiograph with Probabilistic Data Processing

[0204] FIG. **11** is a schematic of an electrocardiograph dynamic state-space model suitable for processing electrocardiogram data, including components required to describe the processes occurring in a subject. The combination of SPKF or SMC filtering in state, joint, or dual estimation modes is optionally used to filter electrocardiograph (ECG) data. Any physiology model adequately describing the ECG signal can be used, as well as any model of noise and artifact sources interfering or contaminating the signal. One non-limiting example of such a model is a model using a sum of arbitrary wave functions with amplitude, center and width, respectively, for each wave (P, Q, R, S, T) in an ECG. The observation model includes the state plus additive Gaussian noise, but more realistic pink noise or any other noise distributions can be used.

[0205] Still referring to FIG. **11**, to facilitate description of the electrocardiograph dynamic state-space model **1105**, a non-limiting example is provided. In this example, the electrocardiograph dynamic state-space model **1105** is further described. The electrocardiograph dynamic state-space model **1105** preferably includes a heart electrodynamics model **1110** corresponding to the dynamic state space model **210** process model **710**. Further, the electrocardiograph dynamic state-space model **1105** preferably includes a heart electrodynamics observation model **1120** corresponding to the dynamic state space model **210** observation model **720**. The electrocardiograph process model **1110** and hemodynamics observation model **1120** are further described, infra.

[0206] Still referring to FIG. **11**, the electrocardiograph process model **1110** optionally includes one or more of a heart electrodynamics model **1112** and a wave propagation model **1114**. The heart electrodynamics **1112** is a physics based probabilistic model of the electrical output of the heart. The wave propagation model **1114** is a physics based probabilistic model of movement of the electrical pulses through the lungs, fat, muscle, and skin. An example of a wave propagation model **1114** is a thorax wave propagation model modeling electrical wave movement in the chest, such as through an organ. The various models optionally share information. For example, the electrical pulse of the heart electrodynamics model **1112** is optionally an input to the wave propagation model **1114**, such as related to one or more multi-lead ECG signals.

[0207] Still referring to FIG. **11**, the electrocardiogram observation model **1120** optionally includes one or more of a sensor noise and interference model **1122**, a sensor dynamics model **1124**, and/or an electrode placement model **1126**. Each of the sensor noise and interference model **1122** and the sensor dynamics models **1124** are physics based probabilistic models related to noises associated with the instrumentation used to collect data, environmental influences on the collected data, and/or noise due to the human interaction with the instrumentation, such as movement of the sensor. The electrode placement model **1126** relates to placement of the elec-

trocardiograph leads on the body, such as on the arm, leg, or chest. As with the electrocardiograph process model **1110**, the sub-models of the electrocardiograph observation model **820** optionally share information. For instance, movement of the sensor noise is added to environmental noise related to changes in room temperature. Optionally and preferably, the electrocardiograph observation model **1120** shares information with and/provides information to the electrocardiograph process model **1110**.

[0208] The electrocardiograph dynamic state-space model **1105** receives inputs, such as one or more of:

[0209] electrocardiograph state parameters **1130**;

[0210] electrocardiograph model parameters **1140**;

[0211] electrocardiograph process noise **1150**; and

[0212] electrocardiograph observation noise **1160**.

[0213] Examples of electrocardiograph state parameters **1130**, corresponding to state parameters **730**, include: atrium signals (AS), ventricle signals (VS) and/or an ECG lead. Examples of electrocardiograph model parameters **1140**, corresponding to the more generic model parameters **740**, include: permittivity, ϵ , and autonomous nervous system (ANS) tone. In this example, the output of the electrocardiograph dynamic state-space model **1105** is a prior probability distribution function with parameters of one or more of the input electrocardiograph state parameters **1130** after operation on by the heart electrodynamics model **1112**, a static number, and/or a parameter not measured or output by the sensor data.

[0214] Referring now to FIG. **12A** and FIG. **12B**, the results of processing a noisy non-stationary ECG signal are shown. Heart rate oscillations representative of normal respiratory sinus arrhythmia are present in the ECG. The processor accomplishes accurate, simultaneous estimation of the true ECG signal and a heart rate that follows closely the true values. Referring now to FIGS. **13A** and FIG. **13B**, the performance of the processor using a noise and artifact-corrupted signal is shown. A clean ECG signal representing one heart beat (truth) was contaminated with additive noise and an artifact in the form of a plateau at R and S peaks (beginning at time=10 sec). Estimates by the processor remain close to the true signal despite the noise and artifact.

[0215] The above description describes an apparatus for generation of a physiological estimate of a physiological process of an individual from input data, where the apparatus includes a biomedical instrument, a biomedical device, and/or a biomedical monitoring device having a data processor configured to run a dual estimation algorithm, where the biomedical monitoring device is configured to produce the input data, and where the input data includes at least one of: a photoplethysmogram and an electrocardiogram. The dual estimation algorithm is configured to use a dynamic state-space model to operate on the input data using both an iterative state estimator and an iterative model parameter estimator in generation of the physiological estimate, where the dynamic state-space model is configured to mathematically represent probabilities of physiological processes that generate the physiological estimate and mathematically represent probabilities of physical processes that affect collection of the input data. Generally, the algorithm is implemented using a data processor, such as in a computer, operable in or in conjunction with a biomedical monitoring device.

[0216] In yet another embodiment, the method, system, and/or apparatus using a probabilistic model to extract physiological information from a biomedical sensor, described

supra, optionally uses a sensor providing time-dependent signals. More particularly, pulse ox and ECG examples were provided, infra, to describe the use of the probabilistic model approach. However, the probabilistic model approach is more widely applicable.

[0217] The above description describes an apparatus for generation of a physiological estimate of a physiological process of an individual from input data, where the apparatus includes a biomedical monitoring device having a data processor configured to run a dual estimation algorithm, where the biomedical monitoring device is configured to produce the input data and where the input data includes at least one of: a photoplethysmogram; and an electrocardiogram. The dual estimation algorithm is configured to use a dynamic state-space model to operate on the input data using both an iterative state estimator and an iterative model parameter estimator in generation of the physiological estimate, where the dynamic state-space model is configured to mathematically represent probabilities of physiological processes that generate the physiological estimate and mathematically represent probabilities of physical processes that affect collection of the input data. Generally, the algorithm is implemented using a data processor, such as in a computer, operable in or in conjunction with a biomedical monitoring device.

[0218] In yet another embodiment, the method, system, and/or apparatus using a probabilistic model to extract physiological information from a biomedical sensor, described supra, optionally uses a sensor providing time-dependent signals. More particularly, pulse ox and ECG examples were provided, infra, to describe the use of the probabilistic model approach. However, the probabilistic model approach is more widely applicable.

[0219] Some examples of physiological sensors used for input into the system with a corresponding physiological model include:

- [0220]** an ECG having two to twelve leads yielding an ECG waveform used to determine an RR-interval and/or various morphological features related to arrhythmias;
- [0221]** pulse photoplethysmography yielding a PPG waveform for determination of hemoglobins and/or total hemoglobin;
- [0222]** capnography or IR absorption yielding a real time waveform for carbon dioxide determination, end-tidal CO₂, an inspired minimum, and/or respiration rate;
- [0223]** a temperature sensor for continuous determination of core body temperature and/or skin temperature;
- [0224]** an anesthetic gas including nitrous oxide, N₂O, and/or carbon dioxide, CO₂, used to determine minimum alveolar concentration of an inhaled anesthetic;
- [0225]** a heart catheter yielding a thermodilution curve for determination of a cardiac index and/or a blood temperature;
- [0226]** an impedance cardiography sensor yielding a thoracic electrical bioimpedance reading for determination of thoracic fluid content, accelerated cardiac index, stroke volume, cardiac output, and/or systemic vascular resistance;
- [0227]** a mixed venous oxygen saturation catheter for determination of SvO₂;
- [0228]** an electroencephalogram (EEG) yielding an EEG waveform and characteristics thereof, such as spectral edge frequency, mean dominant frequency, peak power frequency, compressed spectral array analysis, color

pattern display, and/or delta-theta-alpha-beta band powers, any of which are used for cardiac functions described herein;

- [0229]** electromyography (EMG) yielding an EMG waveform including frequency measures, event detection, and/or amplitude of contraction;
 - [0230]** auscultation yielding sound pressure waveforms;
 - [0231]** transcutaneous blood gas sensors for determination of carbon dioxide, CO₂, and oxygen, O₂;
 - [0232]** a pressure cuff yielding a pressure waveform for determination of systolic pressure, diastolic pressure, mean arterial pressure, heart rate, and/or hemodynamics;
 - [0233]** spirometry combining capnography and flow waveforms for information on respiratory rate, tidal volume, minute volume, positive end-expiratory pressure, peak inspiratory pressure, dynamic compliance, and/or airway resistance;
 - [0234]** fetal and/or maternal sensors, such as ECG and sound (auscultatory) sensors for determination of fetal movement, heart rate, uterine activity, and/or maternal ECG;
 - [0235]** laser Doppler flowmetry yielding a velocity waveform for capillary blood flow rate;
 - [0236]** an ultrasound and/or Doppler ultrasound yielding a waveform, such as a two-dimensional or three-dimensional image, for occlusion of blood vessel walls, blood flow velocity profile, and other body site dependent measures;
 - [0237]** a perspirometer yielding a continuous or semi-continuous surface impedance for information on skin perspiration levels; and
 - [0238]** a digital medical history database to calibrate the model or to screen the database for patient diseases and/or conditions.
- [0239]** Some examples of non-physiological sensors used for input into the system with a corresponding physiological model include:
- [0240]** an accelerometer;
 - [0241]** a three axes accelerometer;
 - [0242]** a gyroscope;
 - [0243]** a compass;
 - [0244]** light or a light reading;
 - [0245]** a global positioning system, for air pressure data, ambient light, humidity, and/or temperature;
 - [0246]** a microphone; and/or
 - [0247]** an ambient temperature sensor.
- [0248]** While specific dynamic state-space models and input and output parameters are provided for the purpose of describing the present method, the present invention is not limited to the described dynamic state-space models, sensors, biological monitoring devices, inputs, and/or outputs.
- [0249]** Diagnosis/Prognosis
- [0250]** Referring now to FIG. 14, the output of the probabilistic digital signal processor 200 optionally is used to diagnose 1410 a system element or component. The diagnosis 1410 is optionally used in a process of prognosis 1420 and/or in control 1430 of the system.
- [0251]** Although the invention has been described herein with reference to certain preferred embodiments, one skilled in the art will readily appreciate that other applications may be substituted for those set forth herein without departing

from the spirit and scope of the present invention. Accordingly, the invention should only be limited by the Claims included below.

1. An apparatus for state parameter estimation, comprising: a monitoring device configured with a system processor, said system processor configured to process sensor data representing a first physical parameter, said processor comprising:
 - a dynamic state-space model configured to provide a prior probability distribution function; and
 - a probabilistic processor configured to operate on the prior probability distribution function to produce a posterior probability distribution function,
 wherein output correlated with the posterior probability distribution function relates to a second physical parameter, wherein said second physical parameter comprises a physical parameter other than said first physical parameter.
2. The apparatus of claim 1, wherein said sensor data comprises data generated using a pulse oximeter, wherein said second physical parameter comprises at least one of:
 - a heart stroke volume;
 - a cardiac output flow rate;
 - an aortic blood pressure;
 - a vasomotor tone; and
 - a radial blood pressure.
3. The apparatus of claim 1, said dynamic state-space model further comprising:
 - a hemodynamic dynamic state-space model comprising at least one equation related to blood movement.
4. The apparatus of claim 3, wherein a hemodynamics state parameter input to said hemodynamics dynamic state-space model comprises at least one of:
 - an aortic pressure; and
 - a radial pressure.
5. The apparatus of claim 1, said dynamic state-space model further comprising at least one of:
 - a hemodynamics process model configured to represent state of a patient over time in terms of said second physical parameter; and
 - a hemodynamics observation model configured to represent processes involved in collecting the sensor data.
6. The apparatus of claim 5, said hemodynamics process model further comprising:
 - a heart model configured to relate cardiac output to heart rate.
7. The apparatus of claim 1, said dynamic state-space model further comprising:
 - a physics based vascular model configured to represent movement of blood in at least one of:
 - arteries;
 - veins; and
 - capillaries.
8. The apparatus of claim 1, said monitoring device comprising a biomedical monitoring device, wherein the sensor data comprises discrete non-probabilistic input data to said probabilistic processor, said probabilistic processor configured to generate a probabilistic output function.
9. The apparatus of claim 1, said probabilistic processor configured to iteratively circulate a probability distribution function through at least two of:
 - said dynamic state-space model;
 - a probabilistic updater; and
 - a probabilistic sampler.

10. A method for state parameter estimation, comprising the steps of:
 - providing sensor data representative of a first physical parameter from a first monitoring device;
 - processing the sensor data using a computer containing a probabilistic digital signal processor configured to use a dynamic state-space model;
 - generating a prior probability distribution function using said dynamic state-space model; and
 - operating on the prior probability distribution function to produce a posterior probability distribution function, wherein output correlated with the posterior probability distribution function relates to a second physical parameter, wherein the second physical parameter comprises a physical parameter other than the first physical parameter.
11. The method of claim 10, wherein the sensor data comprises spectral readings of skin.
12. The method of claim 10, wherein the sensor data comprises electrical readings of skin.
13. The method of claim 10, said step of operating further comprising the step of:
 - using a probabilistic updater to iteratively receive updated sensor data, the sensor data updated in successive iterations of use of said dynamic state-space model.
14. The method of claim 10, further comprising the step of: iteratively converting output of said prior probability distribution function using iterative data of the sensor data to generate iterative output of the posterior probability distribution function.
15. The method of claim 10, further comprising the step of: processing said prior probability distribution function, wherein said prior probability distribution function comprises a first distribution of a parameter, wherein said step of processing generates a second distribution of said parameter, wherein said second distribution comprises a narrower distribution compared to said first distribution.
16. The method of claim 15, wherein said second model parameter distribution comprises a distribution of at least one of:
 - reflectance values;
 - pressure values; and
 - intensity values.
17. The method of claim 10, said probabilistic digital signal processor further configured with at least one of:
 - a light scattering model configured to relate scattered light readings to the second physical parameter; and
 - an absorbance model configured to relate absorbed light readings to the second physical parameter.
18. The method of claim 10, said dynamic state-space model further comprising at least one of the steps of:
 - using a hemodynamic process model to represent state of a patient over time in terms of state parameters; and
 - using a hemodynamic observation model to represent processes involved in collecting the sensor data.
19. The method of claim 18, said observation model further comprising the step of:
 - using a sensor noise model to add noise as a noise probability distribution function to a function representing light values of the sensor data.
20. An apparatus for estimation of a biomedical state of a body, comprising:
 - a digital signal processor integrated into a biomedical device, said processor configured to:
 - iteratively operate on biomedical data representing a first physical parameter;

utilize a physical model representative of at least a component of the body;
process the data to generate a second physical parameter and a third physical parameter using both (1) said physical model and (2) at least one probability distribution function,

wherein the first physical parameter, the second physical parameter, and the third physical parameter represent three different physical parameters, respectively.

* * * * *

专利名称(译)	概率生物医学参数估计设备及其操作方法		
公开(公告)号	US20120277545A1	公开(公告)日	2012-11-01
申请号	US13/096876	申请日	2011-04-28
[标]申请(专利权)人(译)	流线自动化		
申请(专利权)人(译)	流线自动化有限责任公司		
[标]发明人	TEIXEIRA RODRIGO E		
发明人	TEIXEIRA, RODRIGO E.		
IPC分类号	A61B5/00		
CPC分类号	A61B5/0075 A61B5/0205 A61B5/7275 A61B5/441 A61B5/14551 G16H50/30 G16H50/50		
优先权	61/171802 2009-04-22 US 61/372190 2010-08-10 US 61/366437 2010-07-21 US 61/373809 2010-08-14 US		
其他公开文献	US9375171		
外部链接	Espacenet USPTO		

摘要(译)

描述了一种用于医疗功能的概率数字信号处理器。初始概率分布函数被输入到动态状态空间模型，该动态状态空间模型对状态和/或模型概率分布函数进行操作以生成先验概率分布函数，其被输入到概率更新器。概率更新器将传感器数据与先前集成，以产生传递给概率采样器的后验概率分布函数，概率采样器使用后验估计一个或多个参数，其在迭代算法中输出或重新采样。例如，概率处理器使用来自医疗仪表的数据的物理模型来操作，其中医疗仪表使用第一物理参数，例如来自脉搏血氧仪的血氧饱和度水平，以生成不由医疗仪器输出的第二物理参数。仪表，例如心脏搏出量，心输出量和/或血压。

