



US 20110301435A1

(19) **United States**

(12) **Patent Application Publication**
Albert et al.

(10) **Pub. No.: US 2011/0301435 A1**

(43) **Pub. Date: Dec. 8, 2011**

(54) **HEART MONITORING SYSTEM USABLE WITH A SMARTPHONE OR COMPUTER**

Publication Classification

(51) **Int. Cl.**
A61B 5/00 (2006.01)
A61B 5/0402 (2006.01)
(52) **U.S. Cl.** **600/301; 600/509**

(75) **Inventors:** **David Albert**, Oklahoma City, OK (US); **Bruce Richard Satchwell**, Carrara (AU); **Kim Norman Barnett**, Mt. Tamborine (AU)

(57) **ABSTRACT**

A personal monitoring device has a sensor assembly configured to sense physiological signals upon contact with a user's skin. The sensor assembly produces electrical signals representing the sensed physiological signals. A converter assembly, integrated with, and electrically connected to the sensor assembly, converts the electrical signals generated by the sensor assembly to a frequency modulated physiological audio signal having a carrier frequency in the range of from about 6 kHz to about 20 kHz.

(73) **Assignee:** **AliveUSA LLC**

(21) **Appl. No.:** **12/796,188**

(22) **Filed:** **Jun. 8, 2010**

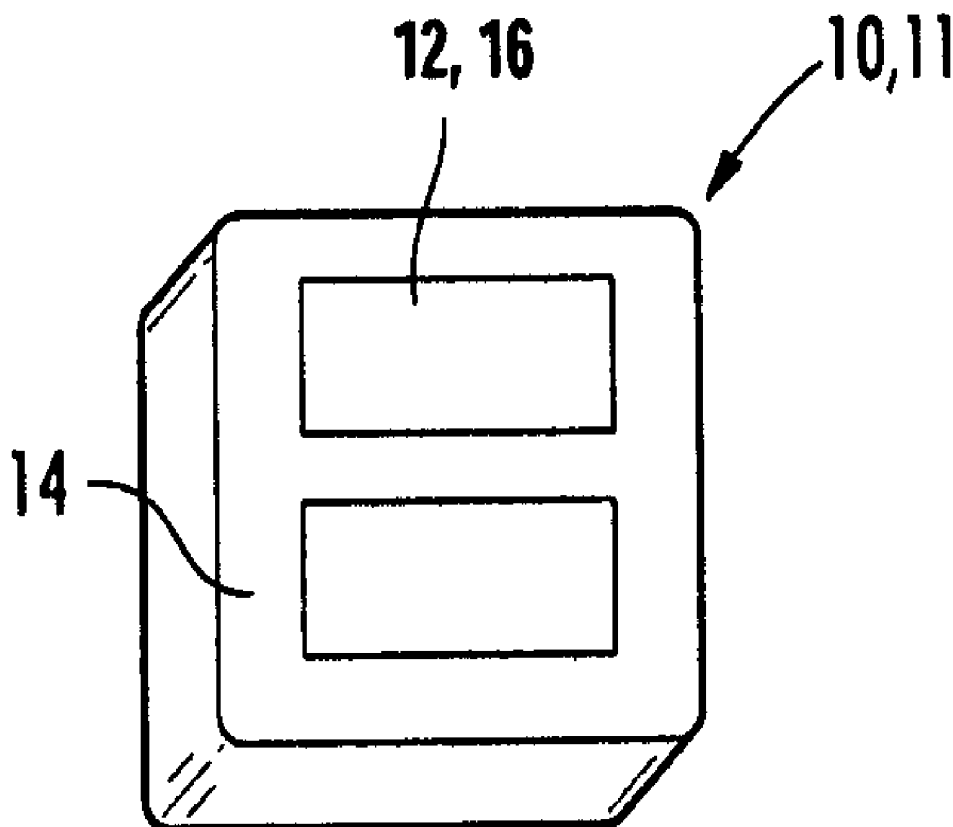

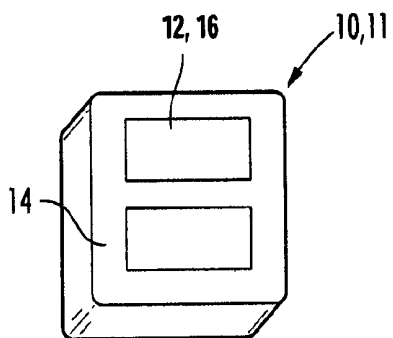

FIG. 1

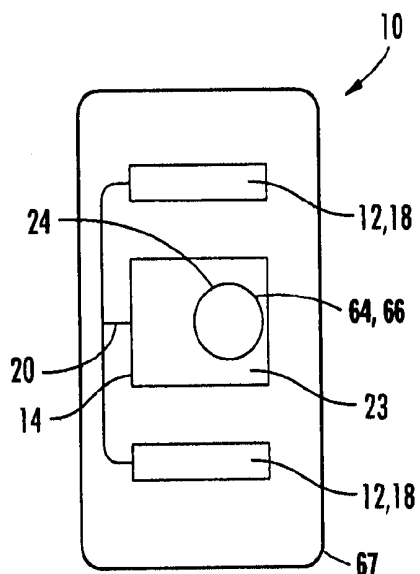

FIG. 2

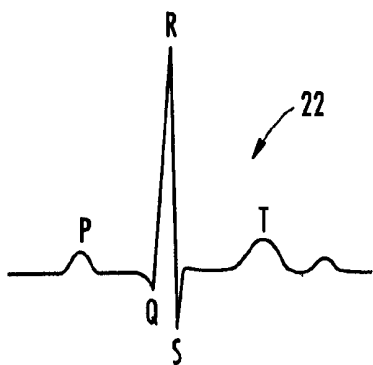

FIG. 3

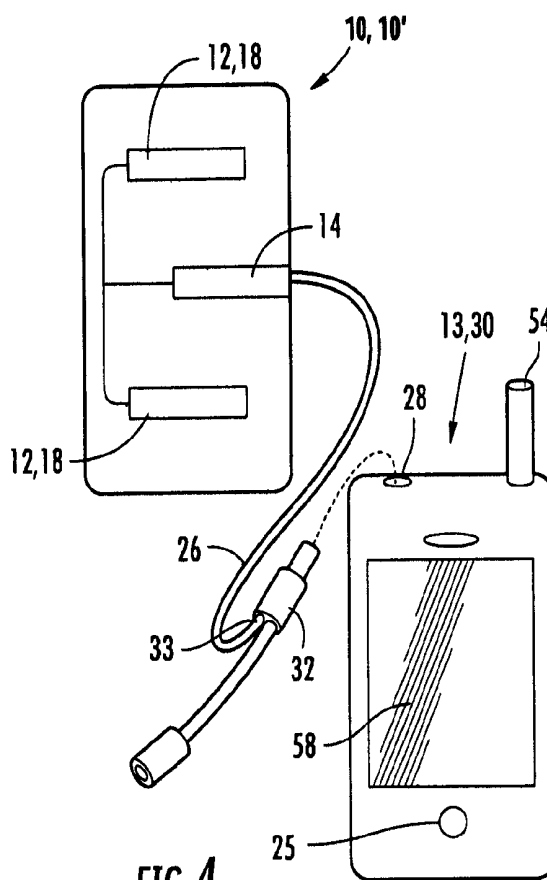

FIG. 4

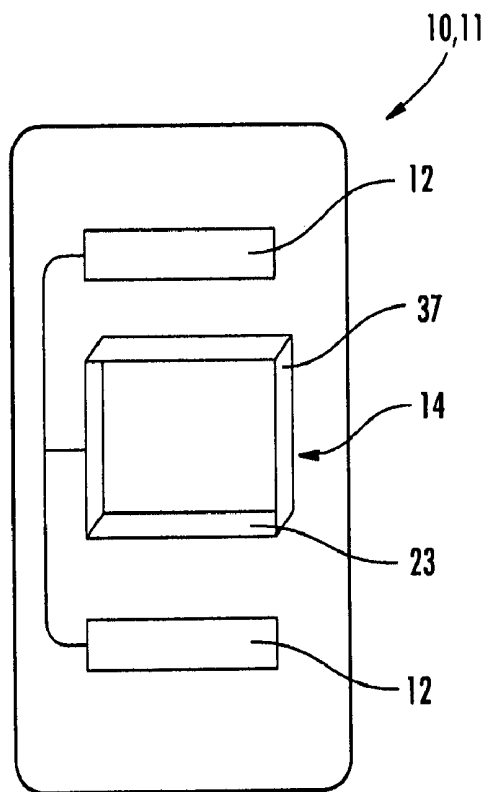

FIG. 5

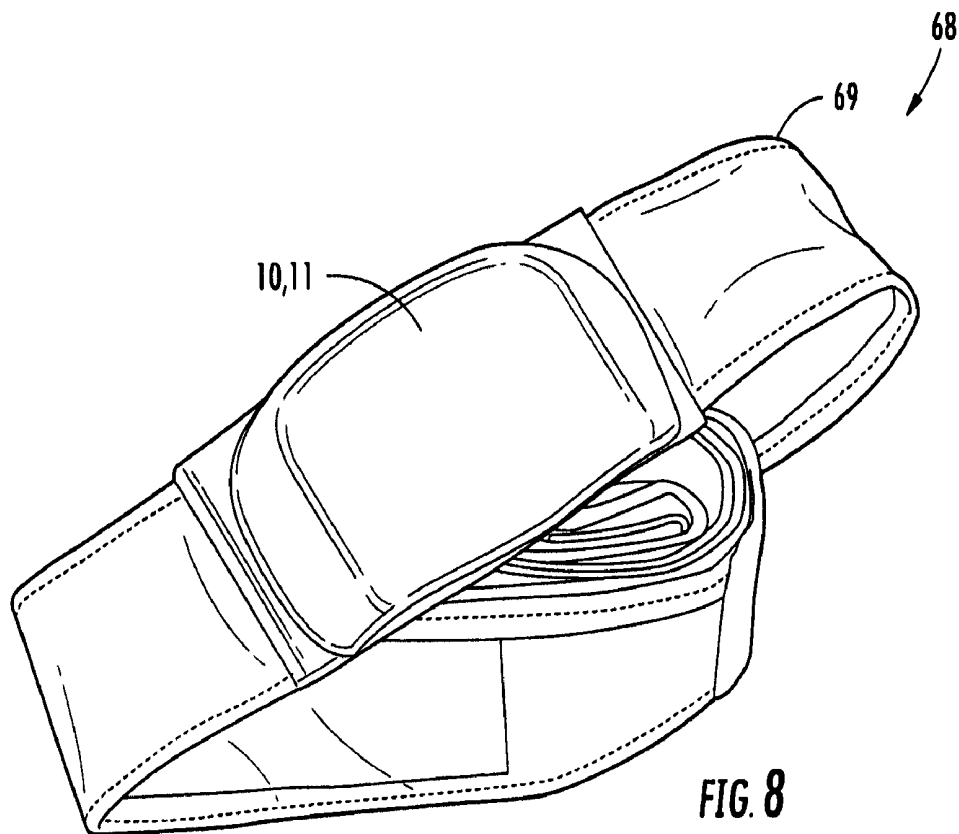

FIG. 8

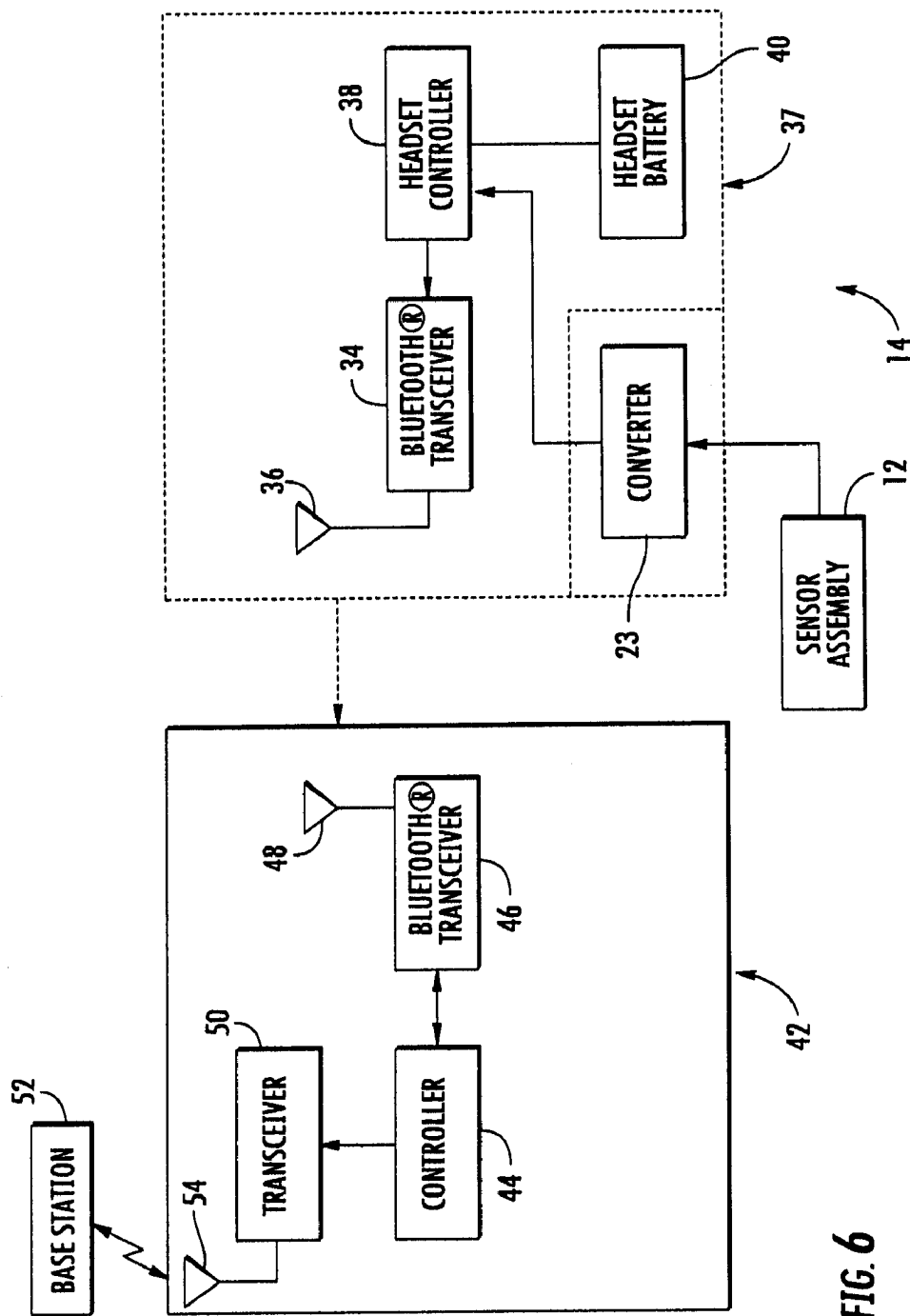

FIG. 6

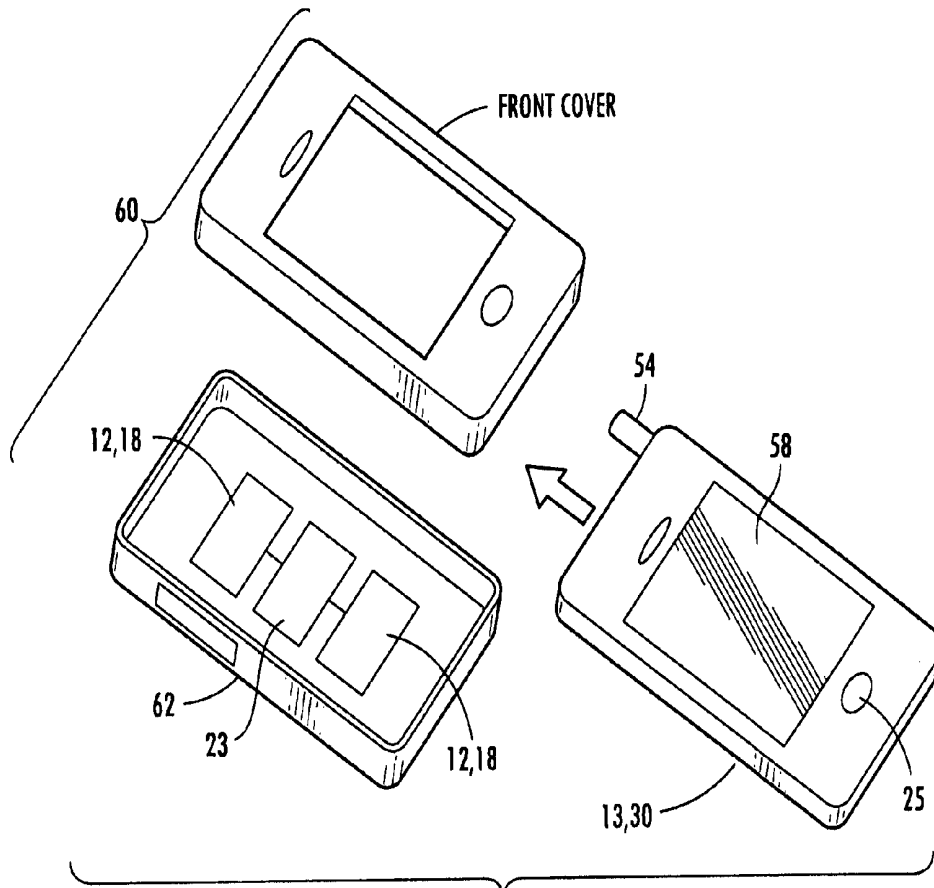

FIG. 7

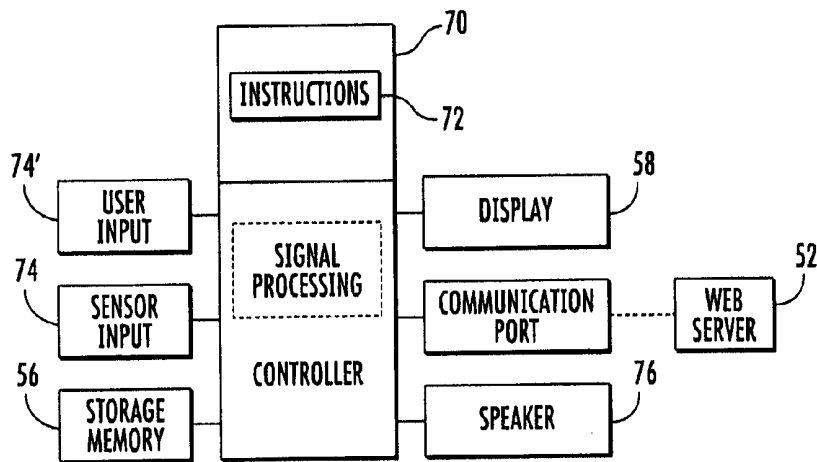

FIG. 9

HEART MONITORING SYSTEM USABLE WITH A SMARTPHONE OR COMPUTER

CROSS REFERENCE TO RELATED APPLICATIONS

[0001] Not Applicable.

STATEMENT REGARDING FEDERALLY SPONSORED RESEARCH OR DEVELOPMENT

[0002] Not applicable.

BACKGROUND

[0003] 1. Field of Invention

[0004] The presently claimed and disclosed inventive concept(s) relates generally to personal physiology monitoring devices and methods and, more particularly, but not by way of limitation, to devices, systems and software for providing ECG, heart rate and cardiac arrhythmia monitoring utilizing a computing device such as a smartphone.

[0005] 2. Background of the Invention

[0006] The prior art includes numerous systems wherein ECG data or the like is monitored and/or transmitted from a patient to a particular doctor's office or health service center. For example, U.S. Pat. No. 5,735,285 discloses use of a handheld device that converts a patient's ECG signal into a frequency modulated audio signal that may then be analyzed by audio inputting via a telephone system to a selected handheld computer device or to a designated doctor's office. Similarly, U.S. Pat. No. 6,264,614 discloses a heart monitor, which is manipulated by the patient to sense a biological function such as a heart beat, and outputs an audible signal to a computer microphone. The computer processes the audible signal and sends resulting data signals over a network or Internet. U.S. Pat. No. 6,685,633 discloses a heart monitor that a patient can hold against his or her chest. The device outputs an audible signal responsive to the function or condition, such as the beating of the heart, to a microphone connected to a computer.

[0007] U.S. Pat. App. Publication No. 20100113950 discloses an electronic device having a heart sensor including several leads for detecting a user's cardiac signals. The leads are coupled to interior surfaces of the electronic device housing to hide the sensor from view. Using the detected signals, the electronic device can then identify or authenticate the user.

[0008] Limitations of the prior art utilizing acoustic signals include a signal to noise ratio that is diminished by talking or any other noisy activity in the vicinity, thus potentially jeopardizing the integrity of the heart monitoring data signals. Additionally, the audible signals can be heard by anyone in the vicinity of the computer and heart monitor, which can be bothersome to the user as well as to others in the vicinity. Other applications fail to provide a reliable, inexpensive personal monitoring device that is readily compatible with existing computing devices such as smartphones. It would be advantageous if these issues were addressed in a personal monitoring device transmitting real time physiological data.

SUMMARY OF THE INVENTION

[0009] Embodiments of the presently claimed and disclosed invention are directed to a personal monitoring device having a sensor assembly configured to sense physiological signals upon contact with a user's skin. The sensor assembly

produces electrical signals representing the sensed physiological signals. A converter assembly, integrated with, and electrically connected to the sensor assembly, converts the electrical signals generated by the sensor assembly to a frequency modulated physiological audio signal. In one embodiment, the frequency modulated physiological audio signal has a carrier frequency in the range of from about 6 kHz to about 20 kHz.

[0010] In another embodiment, the personal monitoring device includes a cable connected to the converter assembly for transmitting the frequency modulated physiological audio signal to a 3.5 mm headphone jack on a smartphone, wherein the converter assembly is electrically isolated from the smartphone by an audio isolation transformer. In this case, the frequency modulated physiological audio signal has a carrier frequency in the range of from about 1 kHz to about 20 kHz.

[0011] In yet another embodiment, the personal monitoring device includes a wireless radio transmitter configured to utilize Bluetooth® headset technology to transmit the frequency modulated physiological audio signal, having a carrier frequency in the range of from about 1 kHz to about 20 kHz, to a Bluetooth® enabled computing device.

[0012] An ECG device of the presently claimed and disclosed inventive concept(s) includes an electrode assembly configured to sense heart-related signals upon contact with a user's skin, and to convert the sensed heart-related signals to an ECG electric signal. A converter assembly, integrated with, and electrically connected to the electrode assembly, is configured to convert the electric ECG signal generated by electrode assembly to a frequency modulated ECG audio signal having a carrier frequency in the range of from about 6 kHz to about 20 kHz.

[0013] In one embodiment, a smartphone protective case, usable as an ECG device, is provided. An electrode assembly, configured to sense heart-related signals upon contact with a user's skin, and to convert the sensed heart-related signals to an ECG electric signal, is provided. A converter assembly, integrated with, and electrically connected to the electrode assembly, is configured to convert the electric ECG signal generated by the electrode assembly to a frequency modulated ECG audio signal having a carrier frequency in the range of from about 6 kHz to about 20 kHz, and further configured to output the ECG audio signal through an audio transmitter at a signal strength capable of being received by a smartphone positioned within the smartphone protective case.

[0014] In a second embodiment, an ECG device is provided in a housing having an electrode assembly configured to sense heart-related signals upon contact with a user's skin, and to convert the sensed heart-related signals to an ECG electric signal. A converter assembly integrated with, and electrically connected to the electrode assembly, is configured to convert the electric ECG signal generated by electrode assembly to a frequency modulated ECG audio signal having a carrier frequency in the range of from about 6 kHz to about 20 kHz, and further configured to output the ECG audio signal through an audio transmitter at a signal strength capable of being received by a smartphone located near the ECG device.

[0015] In another embodiment, an ECG device is provided having an electrode assembly configured to sense heart-related signals upon contact with a user's skin, and to convert the sensed heart-related signals to an ECG electric signal. A converter assembly integrated with, and electrically connected to the electrode assembly, is configured to convert the

electric ECG signal generated by electrode assembly to a frequency modulated ECG audio signal. A cable is provided for transmitting the frequency modulated ECG audio signal to a 3.5 mm headphone jack on a smartphone, wherein the converter assembly is electrically isolated from the smartphone by an audio isolation transformer.

[0016] In yet another embodiment, a computer-readable storage medium is provided for storing a set of instructions capable of being executed by one or more computing devices, causing the one or more computing devices to digitize and demodulate a frequency modulated ECG audio signal having a carrier frequency in the range of from about 6 kHz to about 20 kHz to produce real time demodulated digital ECG data, and to display on a display screen of the computing device, the real time ECG signal represented by the demodulated digital ECG data.

[0017] Thus, utilizing (1) the technology known in the art; (2) the above-referenced general description of the presently claimed and disclosed inventive concept(s); and (3) the detailed description of the invention that follows, the advantages and novelties of the presently claimed and disclosed inventive concept(s) would be readily apparent to one of ordinary skill in the art.

BRIEF DESCRIPTION OF THE DRAWINGS

[0018] FIG. 1 is a schematic representation of an embodiment of a personal monitoring device of the present invention.

[0019] FIG. 2 is a schematic representation of another embodiment of a personal monitoring device of the present invention.

[0020] FIG. 3 is an example of graphical ECG representation.

[0021] FIG. 4 is a schematic representation of an embodiment wherein a personal monitoring device includes an audio cable that can input to a smartphone.

[0022] FIG. 5 is a schematic representation of an embodiment of an ECG device of the present invention utilizing a wireless radio transmitter.

[0023] FIG. 6 is a schematic representation of an embodiment of a personal monitoring device of the present invention connecting via Bluetooth® to a computing device.

[0024] FIG. 7 is a schematic representation of an embodiment of a personal monitoring device of the present invention.

[0025] FIG. 8 is a schematic representation of an embodiment of an ECG device of the present invention included positioned within a chest strap.

[0026] FIG. 9 is a schematic representation of a computer-readable storage medium embodiment of the present invention.

DETAILED DESCRIPTION OF THE INVENTION

[0027] Before explaining at least one embodiment of the invention in detail, it is to be understood that the invention is not limited in its application to the details of construction, experiments, exemplary data, and/or the arrangement of the components set forth in the following description. The invention is capable of other embodiments or of being practiced or carried out in various ways. Also, it is to be understood that the terminology employed herein is for purpose of description and should not be regarded as limiting.

[0028] The presently claimed and disclosed inventive concepts provide a personal monitoring device 10, embodiments of which are shown schematically in FIGS. 1 and 2. The

acquisition electronics 11 of the monitoring device 10 includes a sensor assembly 12 configured to sense physiological signals upon contact with a user's skin. The sensor assembly 12 produces electrical signals representing the sensed physiological signals, which input to a converter assembly 14, integrated with the sensor assembly 12. Converter assembly 14 converts the electrical signals generated by the sensor assembly 12 to a frequency modulated physiological audio signal having a carrier frequency in the range of from about 1 kHz to about 20 kHz. In one embodiment, the frequency modulated physiological audio signal has a carrier frequency in the range of from about 6 kHz to about 20 kHz.

[0029] The sensor assembly 12 can include any suitable sensor operative to detect a physiological signal that a user desires to monitor. Nonlimiting examples of such physiological signals include, but are not limited to, respiration, heart beat, heart rate, electrocardiogram (ECG), electromyogram (EMG), electrooculogram (EOG), pulse oximetry, photoplethysmogram (PPG) and electroencephalogram (EEG).

[0030] A respiration detector can be a conventional microphone assisted stethoscope 16. Heart beat and heart rate can be detected as well using a conventional microphone assisted stethoscope 16, or by using an electrode assembly 18 to sense electrical signals generated by the heart over time. Such electrodes 18 can also be used to detect the electrical activity of the heart over time for electrocardiography (ECG). An ECG is a measurement of the small electrical changes on the skin generated when the heart muscle depolarizes during each heart beat. The output from a pair of electrodes 18 is known as a lead 20. Small rises and falls in the voltage between two electrodes placed on either side of the heart can be processed to produce a graphical ECG representation 22 such as the example ECG shown in FIG. 3.

[0031] Electromyography (EMG) detects the electrical potential generated by muscle cells when the cells are electrically or neurologically activated. The signals can be analyzed to detect medical abnormalities. Electrooculography (EOG) is a technique for measuring the resting potential of the retina. Usually, pairs of electrodes 18 are placed either above and below the eye, or to the left and right of the eye, and a potential difference measurement is a measure for the eye position.

[0032] The oxygenation of a person's hemoglobin can be monitored indirectly in a noninvasive manner using a pulse oximetry sensor, rather than measuring directly from a blood sample. The sensor is placed on a thin part of the person's body, such as a fingertip or earlobe, and a light containing both red and infrared wavelengths is passed from one side to the other. The change in absorbance of each of the two wavelengths is measured and the difference used to estimate oxygen saturation of a person's blood and changes in blood volume in the skin. A photoplethysmogram (PPG) can then be obtained using the pulse oximeter sensor or with an optical sensor using a single light source. The PPG can be used to measure blood flow and heart rate. An electroencephalogram (EEG) can be monitored using electrodes attached to the scalp and measures voltages generated by brain activity.

[0033] The converter assembly 14 converts the electrical signals generated by the sensor assembly 12 to a frequency modulated physiological audio signal that can be received by a computing device 13. In the embodiment shown in FIG. 2, the converter assembly 14 includes a converter 23 and an audio transmitter 24 for outputting frequency modulated physiological signals having a carrier frequency in the range

of from about 6 kHz to about 20 kHz as frequency modulated acoustic signals. Nonlimiting examples of suitable audio transmitters **24** include, but are not limited to, miniature speakers, piezoelectric buzzers, and the like. The acoustic signals can be received by, for example, a microphone **25** in a computing device **13** such as a smartphone, personal digital assistant (PDA), tablet personal computer, pocket personal computer, notebook computer, desktop computer, server computer, and the like.

[0034] Prior art devices have used frequency modulated physiological signals to communicate between acquisition hardware and a computing device. The signals have a carrier frequency within the audible range such as the traditional 1.9 kHz FM frequency used to transmit ECG signals. However, it has been discovered that by using “high frequency” audio frequencies as the carrier, such as frequencies in the range of from about 6 kHz to about 20 kHz, the acoustic communication between the acquisition electronics **11** of the personal monitoring device **10**, and a computing device **13** such as a smartphone, is virtually silent and far more noise-immune than the traditional 1.9 kHz FM ECG frequency. In fact, measurements of the audio signal power in the 1.5 kHz to 15 kHz range determined that carrier frequencies of 6 kHz and higher provide communication that is immune to ambient and voice “noise” contamination. Also, by using a carrier frequency in the 10 kHz to 15 kHz range, we create both a lower noise and a silent communication between the acquisition electronics **11** and the computing device **13** or smartphone. An additional reason for using high carrier frequencies, such as in the 6 kHz to 15 kHz range or in the 10 kHz to 15 kHz range, is to allow simultaneous recording of voice and physiological signals over a single audio channel, where voice and the FM signal are in different frequency bands that can be filtered and separated. The clinical applications of this embodiment can include fast and inexpensive cardiac rhythm diagnosis for physicians as well as personal ECG acquisition for patients.

[0035] In another embodiment, such as that shown in FIG. 4, the converter assembly **14** is configured to convert the electrical signals generated by the sensor assembly **12** to a frequency modulated physiological audio signal which is transmitted by a cable **26** to a 3.5 mm headphone jack **28** on a smartphone **30**. This configuration is totally silent and immune to ambient acoustic noise. In this embodiment the converter assembly **14** is electrically isolated from the smartphone **30** by an audio isolation transformer **32**. The audio isolation transformer **32** preferably conforms to medical safety performance standards such as, for example, those outlined in IEC 60601 along with national and regional deviations. The cable **26** for transmitting the frequency modulated ECG audio signal to the 3.5 mm headphone jack **28** on the smartphone **30** can include a splitter **33** configured, as understood by those skilled in the art, to allow the user to listen to music and voice messages while transmitting the frequency modulated ECG audio signal. The splitter **33** can also allow the user to utilize a mic or headset to record spoken voice messages, such as comments and notes regarding physical symptoms, simultaneously with the ECG audio signal. Using a high carrier frequency of around 10 kHz, or in the 6 kHz to 20 kHz range, allows simultaneous recording of voice and physiological signals over a single audio channel, where the voice and the frequency modulated signal are in different frequency bands that can be readily filtered and separated.

[0036] In yet another embodiment, shown in FIGS. 5 and 6, the converter assembly **14** includes a wireless radio transmitter **37** configured to convert and transmit the electrical signals generated by the sensor assembly **12** using a headset profile (HSP) of the Bluetooth® wireless communications standard is defined by the Bluetooth Special Interest Group (SIG) and available at URL address www.bluetooth.org. The electrical signals generated by the sensor assembly **12** are converted and transmitted using a Bluetooth® transceiver **34** and antenna **36** and communicated to the computing device **13**, preferably a smartphone **30**, according to instructions provided by a headset controller **38**. Economy, as well as isolation and convenience, are provided by using a commercially available headset controller **38**, Bluetooth® transceiver **34**, and antenna **36**, powered by a headset battery **40**, wherein the electronics are commercially configured and mass-produced for communicating with computing devices **13** such as smartphones **30**.

[0037] Computing device electronics **42** typically include a controller **44**, a Bluetooth® transceiver **46** and antenna **48** for receiving input from a wireless Bluetooth® device. Most computing devices, and all smartphones, include a memory **56**, a display screen **58**, and a transceiver **50** for transmitting/receiving information signals to/from a base station or web server **52** via a cellular antenna **54**. Thus, the computing device electronics **42** can be used to store information from the personal monitoring device **10** in memory **56**, and/or transmit the information to the base station **52** or a specific communication address via wireless communication technology well understood by those skilled in the art.

[0038] In some cases, the personal monitoring device **10** can be considered an ECG device **10'** and includes an electrode assembly **18** configured to sense heart-related signals upon contact with a user's skin, and to convert the sensed heart-related signals to an ECG electric signal. As discussed in detail hereinafter, the ECG device **10'** transmits a frequency modulated ECG audio signal to a smartphone **30** via a wired audio jack connection, a wireless headset, or acoustically. Software running on the smartphone **30** digitizes and processes the audio in real-time, where the frequency modulated ECG signal is demodulated. The ECG can be further processed using algorithms to calculate heart rate and identify arrhythmias. The ECG, heart rate, and rhythm information can be displayed on the smartphone **30**, stored locally for later retrieval, and/or transmitted in real-time to a web server **52** via a 2G/3G, WiFi or other Internet connection on the smartphone **30**. In addition to the display and local processing of the ECG data, the smartphone **30** can transmit, in real-time, the ECG, heart rate and rhythm data via a secure web connection for viewing, storage and further analysis via a web browser interface (using the 2G/3G or WiFi connectivity of the smartphone **30**). Server software provides for storage, further processing, real-time or retrospective display and formulation of a PDF ECG rhythm strip document and/or other reports and formats for printing remotely or locally.

[0039] In one embodiment, the converter assembly **14** of ECG device **10'** is integrated with, and electrically connected to the electrode assembly **18** and is configured to convert the electric ECG signal generated by electrode assembly **18** to a frequency modulated ECG audio signal having a carrier frequency in the range of from about 6 kHz to about 20 kHz. It is sometimes desirable to utilize a carrier frequency in the 10 kHz to 15 kHz range in order to create both a lower noise and

a silent communication between the acquisition electronics 11 and the computing device 13 or smartphone 30.

[0040] In one configuration, the ECG device 10' is usable as a smartphone protective case 60 as shown in FIG. 7. One example configuration utilizes a "slip-on" protective case 60 for an iPhone® or other smartphone 30, the protective case 60 including an integrated ECG electrode assembly 18 and acquisition electronics 11 (2, 3 or 4 electrodes for generating a single lead of ECG data). The ECG electrodes are located on the side 62 of the case 60 opposite of the display screen 58. The smartphone 30, in its ECG-adapted protective case 60, is held in both hands (generating a lead one, Left Arm minus Right Arm) or is placed on a person's chest to generate a modified chest lead. The ECG is measured by the acquisition electronics 11 and converted into a frequency modulated signal with a carrier or center frequency from about 6 kHz to 20 kHz, or in some embodiments from 10 kHz to 15 kHz. The frequency modulated signal is output by a miniature speaker 64 or a piezoelectric buzzer 66.

[0041] In another configuration, the ECG device 10', as shown schematically in FIG. 2, is usable as a standalone real-time ECG acquisition device. The ECG device is identical to the "case" electronics, but is present in its own housing 67 rather than being integrated into a protective case 60 for a smartphone 30. This embodiment allows for use of the device to acquire ECG data and have it communicated acoustically to a PC or other computing device for demodulation, processing, storage and display via a web application and connection.

[0042] In either configuration, the smartphone 30 utilizes its built-in microphone 25 and CPU to acquire, digitize, demodulate, process and then display the ECG data in real-time. Also, the smartphone 30 can calculate a real-time heart rate measurement and determine a cardiac rhythm diagnosis like atrial fibrillation. The smartphone 30 can utilize its 2G, 3G, Bluetooth® and WiFi connectivity to transmit the ECG and other data to a secure web server 52 for real-time distant display, storage and analysis. Also, the ECG data can be stored locally on the smartphone 30 for later review or transmission.

[0043] In another embodiment, shown schematically in FIG. 8, the ECG device 10' is usable as a chest strap device 68 like a fitness heart rate monitor. The chest strap 69 with integrated ECG electrode assembly 18 and acquisition electronics 11 "pod" generate the frequency modulated ECG signal and send it by one of two modes to the smartphone 30. In one mode, a cable 26, as described above, plugs into the 3.5 mm headphone jack 28 on the iPhone®, Blackberry® or other smartphone 30 which provides an audio input (normally used for a headphone mic). This configuration is totally silent and immune to ambient acoustic noise. The ECG data is isolated from the smartphone 30 by an audio isolation transformer 32. In another mode, the frequency modulated audio signal is transmitted by a Bluetooth® headset chip, as described above, and the smartphone 30 receives it and performs the other processing steps. This configuration preferably makes use of mass-produced headset electronics and includes a rechargeable battery. This configuration is wireless, which provides isolation and convenience.

[0044] Software on the smartphone 30 can also combine data and signals from other sensors built into the smartphone 30 such as a GPS and accelerometer. Further processing of this data provides additional information related to the user, such as speed, location, distance, steps, cadence, body position, fall detection and energy expenditure. The raw signals

from the sensors and derived information can be displayed and stored locally on the smartphone 30, as well as being transmitted to the web server 52 over an Internet connection. Software on the web server 52 provides a web browser interface for real-time or retrospective display of the signals and information received from the smartphone 30, and also includes further analysis and reporting.

[0045] Referring now to FIG. 9, a computer-readable storage medium 56 stores a set of instructions 72, wherein the instructions 72 are capable of being executed by one or more computing devices 13. Nonlimiting examples of suitable computing devices 13 include smartphones 30, personal digital assistants (PDAs), tablet personal computers, pocket personal computers, notebook computers, desktop computers, and server computers. When executed, the one or more computing devices 13 is caused to digitize and demodulate a sensor input 74 such as a frequency modulated ECG audio signal having a carrier frequency in the range of from about 6 kHz to about 20 kHz to produce real-time demodulated digital ECG data. The instructions 72 can cause the real-time demodulated digital ECG data to display on a display screen 58 of the computing device 13.

[0046] Sensor input 74 can also include real-time information from additional sensors as well as user input 74'. For example, in embodiments wherein the computing device 13 is a smartphone 30, the input 74 can include real-time information from a GPS and/or accelerometer in the smartphone 30 in addition to the demodulated digital ECG data. User input 74' can also include spoken voice messages entered through a microphone of the computing device 13. Instructions 72 can cause the sensor and/or user input 74 and 74' to be recorded and maintained in a storage memory 56 of the computing device 13.

[0047] In one embodiment, the set of instructions 72, when executed by the one or more computing devices 13, can further cause the one or more computing devices 13 to calculate and display in real-time, a heart rate represented by the frequency modulated ECG audio signal. In addition, demodulated digital ECG data can be processed to identify the occurrence of an arrhythmia. In such designs, the storage medium 70 can include instructions 72 to cause the computing device 13 to display a warning on a display screen 58 or emit an audible alert through the speaker 76 at the occurrence of an arrhythmia.

[0048] Instructions 72 can cause the computing device 13 to store the demodulated digital ECG data in a memory 56 of the one or more computing devices 13 for later retrieval. The set of instructions 72 can further cause the one or more computing devices 13 to retrieve and transmit, upon demand, the stored demodulated digital ECG data to a web server 52 via an internet connection on the computing device 13. Recorded spoken voice messages can be stored and transmitted to the web server 52, simultaneously with the demodulated digital ECG data.

[0049] In other embodiments, the instructions 72 can cause the one or more computing devices 13 to transmit the demodulated digital ECG data, and/or voice messages, to the web server 52 in real-time.

[0050] A version of the smartphone software is packaged as a software library that can be integrated with other third party software applications. This provides a simplified and standard method for third party applications to use the ECG device 10' to obtain heart rate and other derived information

without having to develop their own data acquisition, demodulation, and signal processing algorithms.

[0051] A version of the software also runs on a PC and includes demodulation, processing, storage and transmission to the web server **52**. The software includes the audio acquisition, demodulation, ECG analysis, and acceleration analysis modules.

[0052] The audio acquisition module selects the appropriate audio input and samples the audio. On the iPhone®, audio is sampled and processed using the audio unit framework, which provides low latency audio acquisition and processing. The audio unit framework also allows automatic selection of the appropriate audio source, internal mic, audio jack connection, or Bluetooth® headset. The sampling rate will typically be at 44 kHz when the modulation carrier frequency is greater than 10 kHz, but for lower carrier frequencies, it may use a lower audio sampling rate. On other devices this module will use the most appropriate API's for efficient, low latency audio sampling.

[0053] The demodulation module demodulates a frequency modulated ECG audio signal, using a linear approximation and zero crossings algorithm. The demodulator allows selection of different modulation parameters to match the particular ECG device. Demodulation using zero crossings and linear approximation works well for carrier frequencies 6 kHz and lower and has the advantage that it is simple and fast. Above 10 kHz with 44 kHz sampling, the errors from linear approximation become large, although the effect is somewhat reduced if applying a 40 Hz filter to the demodulated ECG. Application of sine or other curve fitting methods can be used to reduce the error associated with linear approximation for carrier frequencies above 10 kHz. Audio samples from the audio acquisition module are first passed through a digital band-pass filter to remove unwanted frequencies outside the modulation range. The digital band-pass filter is most effective when receiving acoustically coupled audio which can be contaminated with noise. When using a center frequency above 6 kHz, the band-pass filter is able to provide good noise immunity from voice and background ambient noise which is typically below 5 kHz. The band-pass filter stage could be eliminated to save processing power when receiving audio via a wired or Bluetooth® connection which would not be susceptible to background noise contamination. To demodulate the signal it is necessary to estimate the frequency of the audio waveform. The algorithm looks at the sign of incoming data. When the sign changes it draws a straight line between the two points and interpolates the zero value. It uses this to determine the average frequency over a 3.333 ms interval, which provides ECG data at the output sampling rate of 300 Hz.

[0054] The ECG analysis module includes algorithms that process the ECG to detect and classify beats, and provides a heart rate estimate. Beat-to-beat heart rate is calculated from the interval between beats and a more robust measurement of heart rate is calculated using median filtering of the RR intervals.

[0055] The acceleration analysis module includes algorithms that process signals from the built-in 3 axis accelerometer sensor in the smartphone **30**, to derive an estimate of a person's energy expenditure, steps, cadence, and body position and to detect falls.

[0056] From the above descriptions, it is clear that the presently disclosed and claimed inventive concept(s) are well adapted to carry out the objects and to attain the advantages

mentioned herein, as well as those inherent in the presently disclosed and claimed inventive concept(s). While the presented embodiments have been described for purposes of this disclosure, it will be understood that numerous changes may be made which will readily suggest themselves to those skilled in the art and which are accomplished within the spirit of the presently disclosed and claimed inventive concept(s).

What is claimed is:

1. A personal monitoring device comprising:

a sensor assembly configured to sense physiological signals upon contact with a user's skin and to produce electrical signals representing the sensed physiological signals; and

a converter assembly integrated with, and electrically connected to the sensor assembly, the converter assembly configured to convert the electrical signals generated by the sensor assembly to a frequency modulated physiological audio signal having a carrier frequency in the range of from about 6 kHz to about 20 kHz.

2. The personal monitoring device of claim 1, wherein the converter assembly comprises an audio transmitter for outputting the frequency modulated physiological audio signal as a frequency modulated physiological acoustic signal having a carrier frequency in the range of from about 6 kHz to about 20 kHz.

3. The personal monitoring device of claim 2, wherein the audio transmitter is configured to output the physiological acoustic signal to a microphone in a computing device within range of the audio transmitter.

4. The personal monitoring device of claim 1, wherein the physiological signals sensed are selected from the group consisting of electrocardiogram (ECG), electromyogram (EMG), electrooculogram (EOG), photoplethysmogram (PPG), respiration, heart rate, pulse oximetry, electroencephalogram (EEG) and a combination thereof.

5. A personal monitoring device comprising:

a sensor assembly configured to sense physiological signals upon contact with a user's skin, and to produce electrical signals representing the sensed physiological signals;

a converter assembly integrated with, and electrically connected to the sensor assembly, the converter assembly configured to convert the electrical signals generated by the sensor assembly to a frequency modulated physiological audio signal; and

a cable connected to the converter assembly for transmitting the frequency modulated physiological audio signal to a 3.5 mm headphone jack on a smartphone, wherein the converter assembly is electrically isolated from the smartphone by an audio isolation transformer.

6. The personal monitoring device of claim 5, wherein the physiological signals sensed are selected from the group consisting of electrocardiogram (ECG), electromyogram (EMG), electrooculogram (EOG), photoplethysmogram (PPG), respiration, heart rate, pulse oximetry, electroencephalogram (EEG) and a combination thereof.

7. A personal monitoring device comprising:

a sensor assembly configured to sense physiological signals upon contact with a user's skin, and to produce electrical signals representing the sensed physiological signals;

a converter assembly integrated with, and electrically connected to the sensor assembly, the converter assembly configured to convert the electrical signals generated by

the sensor assembly to a frequency modulated physiological audio signal, the converter assembly further comprising a wireless radio transmitter configured to utilize Bluetooth® headset technology to transmit the frequency modulated physiological audio signal via a short distance wireless network to a Bluetooth® enabled computing device.

8. The personal monitoring device of claim 7, wherein the physiological signals sensed are selected from the group consisting of electrocardiogram (ECG), electromyogram (EMG), electrooculogram (EOG), photoplethysmogram (PPG), respiration, heart rate, pulse oximetry, and a combination thereof.

9. An ECG device comprising:

an electrode assembly configured to sense heart-related signals upon contact with a user's skin, and to convert the sensed heart-related signals to an ECG electric signal; and

a converter assembly integrated with, and electrically connected to the electrode assembly, the converter assembly configured to convert the electric ECG signal generated by electrode assembly to a frequency modulated ECG audio signal having a carrier frequency in the range of from about 6 kHz to about 20 kHz.

10. The ECG device of claim 9, wherein the frequency modulated ECG audio signal has a carrier frequency in the range of from about 10 kHz to about 15 kHz.

11. The ECG device of claim 9, wherein the electrode assembly comprises two electrodes.

12. The ECG device of claim 9, wherein the converter assembly comprises an audio transmitter for outputting the frequency modulated ECG audio signal as a frequency modulated ECG acoustic signal.

13. The ECG device of claim 12, wherein the audio transmitter is a speaker.

14. The ECG device of claim 12, wherein the audio transmitter is a piezoelectric buzzer.

15. The ECG device of claim 12, wherein the audio transmitter is configured to output the ECG acoustic signal to a microphone in a computing device within range of the audio transmitter.

16. The ECG device of claim 15, wherein the computing device is selected from the group consisting of smartphones, personal digital assistants (PDAs), tablet personal computers, pocket personal computers, notebook computers, desktop computers, and server computers.

17. The ECG device of claim 12, wherein the electrode assembly is positioned on an outer surface of a smartphone protective case, and wherein the ECG acoustic signal output from the audio transmitter is detectable by a microphone in a smartphone when the smartphone is positioned within the smartphone protective case.

18. The ECG device of claim 12, wherein the frequency modulated ECG audio signal has a carrier frequency in the range of from about 10 kHz to about 15 kHz.

19. A smartphone protective case, usable as an ECG device, comprising:

an electrode assembly configured to sense heart-related signals upon contact with a user's skin, and to convert the sensed heart-related signals to an ECG electric signal; and

a converter assembly integrated with, and electrically connected to the electrode assembly, the converter assembly configured to convert the electric ECG signal generated

by the electrode assembly to a frequency modulated ECG audio signal having a carrier frequency in the range of from about 6 kHz to about 20 kHz, and further configured to output the ECG audio signal through an audio transmitter at a signal strength capable of being received by a smartphone positioned within the smartphone protective case.

20. An ECG device, contained at least partially within a housing, the ECG device comprising:

an electrode assembly connected to the housing, the electrode assembly configured to sense heart-related signals upon contact with a user's skin, and to convert the sensed heart-related signals to an ECG electric signal; and

a converter assembly integrated with, and electrically connected to the electrode assembly, the converter assembly configured to convert the electric ECG signal generated by the electrode assembly to a frequency modulated ECG audio signal having a carrier frequency in the range of from about 6 kHz to about 20 kHz, and further configured to output the ECG audio signal through an audio transmitter.

21. An ECG device comprising:

an electrode assembly configured to sense heart-related signals upon contact with a user's skin, and to convert the sensed heart-related signals to an ECG electric signal;

a converter assembly integrated with, and electrically connected to the electrode assembly, the converter assembly configured to convert the electric ECG signal generated by electrode assembly to a frequency modulated ECG audio signal; and

a cable for transmitting the frequency modulated ECG audio signal to a 3.5 mm headphone jack on a smartphone, wherein the converter assembly is electrically isolated from the smartphone by an audio isolation transformer.

22. The ECG device of claim 21, wherein the electrode assembly is positioned within a chest strap.

23. The ECG device of claim 21, wherein the audio isolation transformer provides medical grade isolation.

24. The ECG device of claim 21, wherein the cable for transmitting the frequency modulated ECG audio signal to the 3.5 mm headphone jack on the smartphone includes a splitter configured to allow the user to listen to music and voice messages while transmitting the frequency modulated ECG audio signal.

25. The ECG device of claim 24, wherein the splitter is further configured to allow the user to record spoken voice messages to record comments and symptoms.

26. An ECG device comprising:

an electrode assembly configured to sense heart-related signals upon contact with a user's skin, and to convert the sensed heart-related signals to an ECG electric signal;

a converter assembly integrated with, the electrode assembly, the converter assembly configured to convert the electric ECG signal generated by electrode assembly to a frequency modulated ECG audio signal; and

a wireless radio transmitter configured to utilize Bluetooth headset technology to transmit the frequency modulated ECG audio signal to a computing device.

27. The ECG device of claim 26, wherein the electrode assembly is positioned within a chest strap.

28. A computer-readable storage medium storing a set of instructions capable of being executed by one or more computing devices, that when executed by the one or more computing devices causes the one or more computing devices to: digitize and demodulate a frequency modulated ECG audio signal having a carrier frequency in the range of from about 6 kHz to about 20 kHz to produce real time demodulated digital ECG data, and to display on a display screen of the computing device, the real-time ECG signal represented by the demodulated digital ECG data.

29. The computer-readable storage medium of claim **28**, wherein the computing device is a smartphone.

30. The computer-readable storage medium of claim **29**, wherein the set of instructions, when executed by the one or more smartphones, further causes the smartphone to record real-time information from a GPS and/or accelerometer in the smartphone.

31. The computer-readable storage medium of claim **28**, wherein the set of instructions, when executed by the one or more computing devices, further causes the one or more computing devices to record spoken voice messages simultaneously with the real-time demodulated digital ECG data.

32. The computer-readable storage medium of claim **28**, wherein the set of instructions, when executed by the one or more computing devices, further causes the one or more computing devices to calculate and display in real-time, a heart rate represented by the frequency modulated ECG audio signal.

33. The computer-readable storage medium of claim **28**, wherein the set of instructions, when executed by the one or more computing devices, further causes the one or more computing devices to process the demodulated digital ECG data to identify the occurrence of an arrhythmia.

34. The computer-readable storage medium of claim **33**, wherein the set of instructions, when executed by the one or

more computing devices, further causes the one or more computing devices to display a warning at the occurrence of an arrhythmia.

35. The computer-readable storage medium of claim **28**, wherein the set of instructions, when executed by the one or more computing devices, further causes the one or more computing devices to store the demodulated digital ECG data in a memory of the one or more computing devices for later retrieval.

36. The computer-readable storage medium of claim **35**, wherein the set of instructions, when executed by the one or more computing devices, further causes the one or more computing devices to retrieve and transmit, upon demand, the stored demodulated digital ECG data to a web server via an internet connection on the computing device.

37. The computer-readable storage medium of claim **36**, wherein the set of instructions, when executed by the one or more computing devices, further causes the one or more computing devices to record spoken voice messages simultaneously with the demodulated digital ECG data, and to transmit the spoken voice messages with the demodulated digital ECG data to the web server.

38. The computer-readable storage medium of claim **28**, wherein the set of instructions, when executed by the one or more computing devices, further causes the one or more computing devices to transmit the demodulated digital ECG data to a web server in real-time.

39. The computer-readable storage medium of claim **38**, wherein the set of instructions, when executed by the one or more computing devices, further causes the one or more computing devices to record spoken voice messages simultaneously with the demodulated digital ECG data, and to transmit the spoken voice messages with the demodulated digital ECG data to the web server.

* * * * *

专利名称(译)	可用于智能手机或计算机的心脏监测系统		
公开(公告)号	US20110301435A1	公开(公告)日	2011-12-08
申请号	US12/796188	申请日	2010-06-08
[标]申请(专利权)人(译)	ALIVEUSA		
申请(专利权)人(译)	ALIVEUSA LLC		
当前申请(专利权)人(译)	ALIVECOR INC.		
[标]发明人	ALBERT DAVID SATCHWELL BRUCE RICHARD BARNETT KIM NORMAN		
发明人	ALBERT, DAVID SATCHWELL, BRUCE RICHARD BARNETT, KIM NORMAN		
IPC分类号	A61B5/00 A61B5/0402		
CPC分类号	A61B5/0404 A61B5/055 A61B5/0402 A61B2560/045 A61B2560/0468 A61B2505/07 A61B5/0205 A61B5/02416 A61B5/02438 A61B5/04085 A61B5/0476 A61B5/0488 A61B5/0816 A61B5/6898 A61B5/742		
其他公开文献	US8509882		
外部链接	Espacenet USPTO		

摘要(译)

个人监测设备具有传感器组件，该传感器组件被配置为在与用户的皮肤接触时感测生理信号。传感器组件产生表示所感测的生理信号的电信号。与传感器组件集成并电连接的转换器组件将由传感器组件产生的电信号转换成频率调制的生理音频信号，其载波频率在约6kHz至约20kHz的范围内。

