



(19) **United States**

(12) **Patent Application Publication**

(10) **Pub. No.: US 2003/0166996 A1**

Kim et al.

(43) **Pub. Date:**

Sep. 4, 2003

(54) **METHOD AND APPARATUS FOR MEASURING ANIMAL'S CONDITION BY ACQUIRING AND ANALYZING ITS BIOLOGICAL SIGNALS**

(57) **ABSTRACT**

(75) Inventors: **Kyung-hwan Kim**, Seongnam-city (KR); **Seok-won Bang**, Seoul (KR); **Hyoung-ki Lee**, Suwon-city (KR)

A method and apparatus for measuring the biological condition of an animal by acquiring and analyzing its biological signals are provided. The biological signals from skin temperature, a photoplethysmogram (PPG), an electrocardiogram (ECG), electrodermal activity (EDA), an electromyogram (EMG), and an electrogastrogram (EGG) are detected using a biological signal detection unit which is attached to the animal's skin. Feature vectors, including the mean heart rate of the photoplethysmogram and its standard deviation, the very low frequency, low frequency, and high frequency components of heart rate variability, the frequency and mean amplitude of skin conductance responses, and the mean and maximum skin temperatures, are extracted from the detected biological signals. The biological condition, including needs and emotions, of the animal as to whether or not the animal feels hunger or fear, how much the animal is stressed, or whether or not the animal needs to have a bowel movement, is determined using a pattern classifier which has learned reference vectors, which reflect the behaviors, needs, and emotions of different kinds of animals for various biological conditions and are stored in a predetermined database. Therefore, the biological condition of the animal can be determined through instrumental communication, not through human languages, and the breeding of pets can be efficiently managed.

Correspondence Address:
BURNS DOANE SWECKER & MATHIS L L P
POST OFFICE BOX 1404
ALEXANDRIA, VA 22313-1404 (US)

(73) Assignee: **Samsung Electronics Co., Ltd.**, Suwon-city (KR)

(21) Appl. No.: **10/339,461**

(22) Filed: **Jan. 10, 2003**

(30) **Foreign Application Priority Data**

Jan. 11, 2002 (KR) 2002-1696

Publication Classification

(51) **Int. Cl.⁷** **A61B 5/00**

(52) **U.S. Cl.** **600/300**

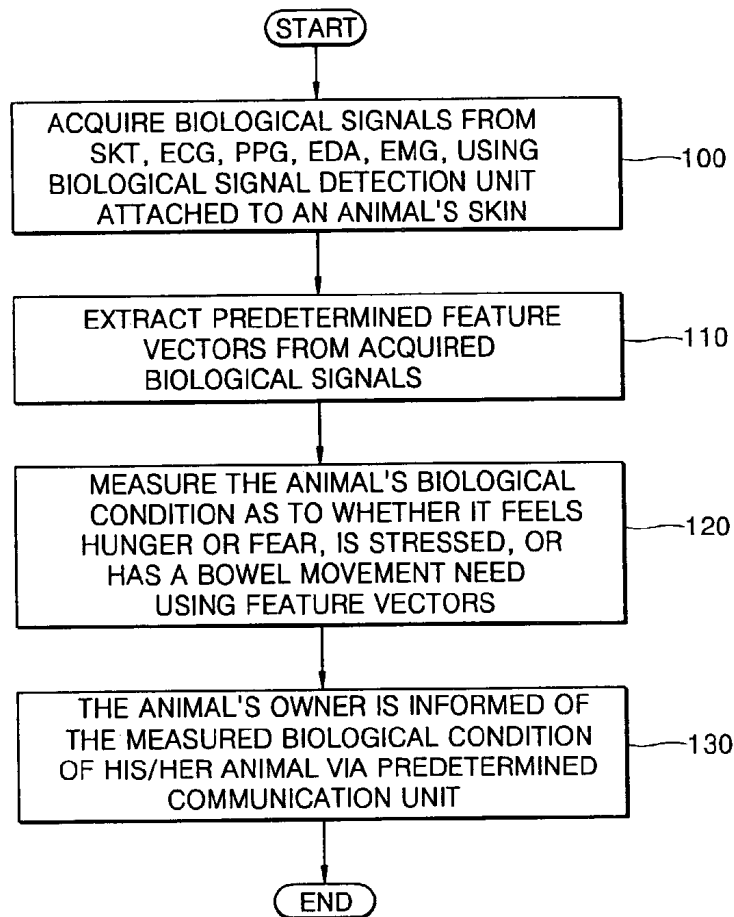

FIG. 1

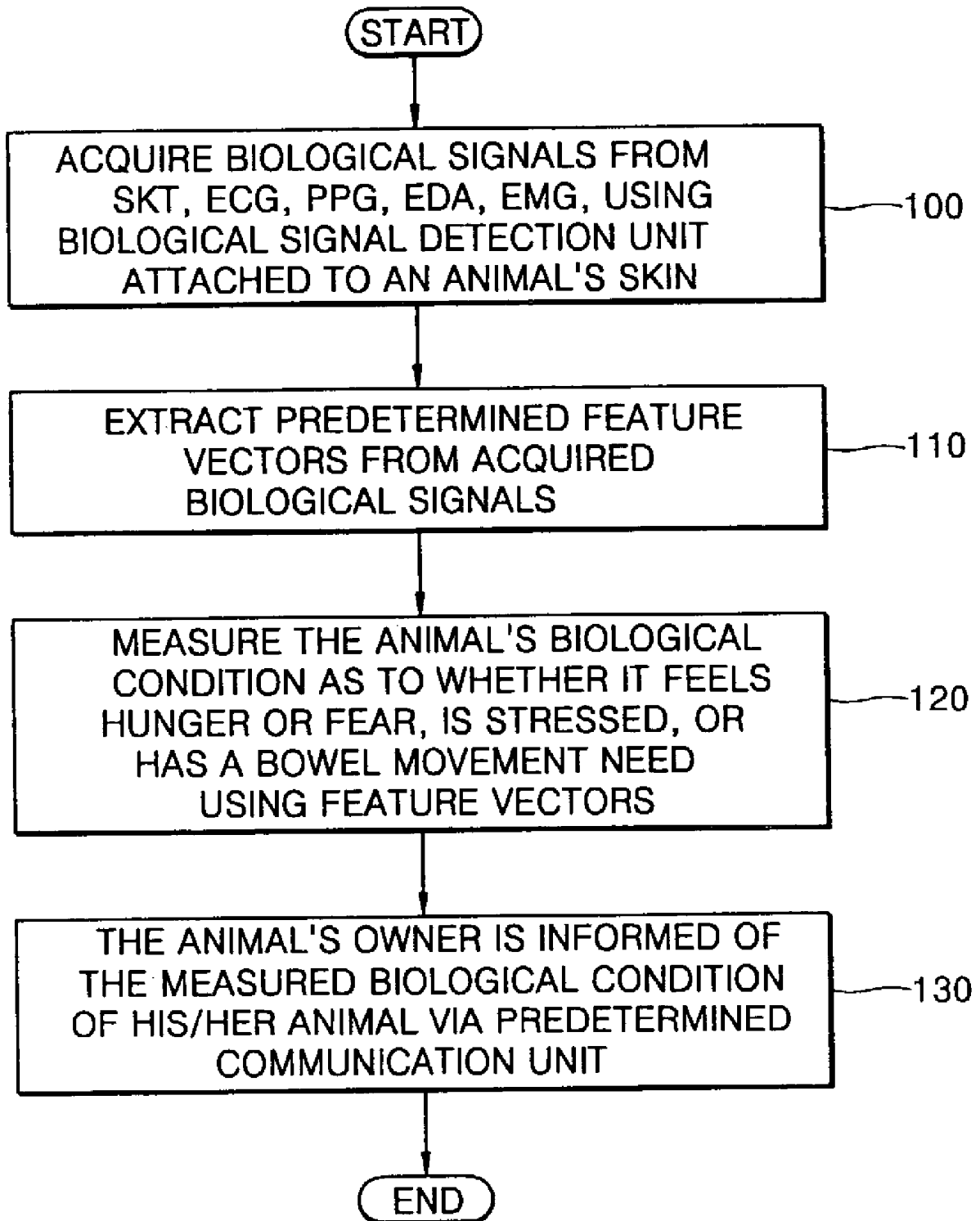

FIG. 2

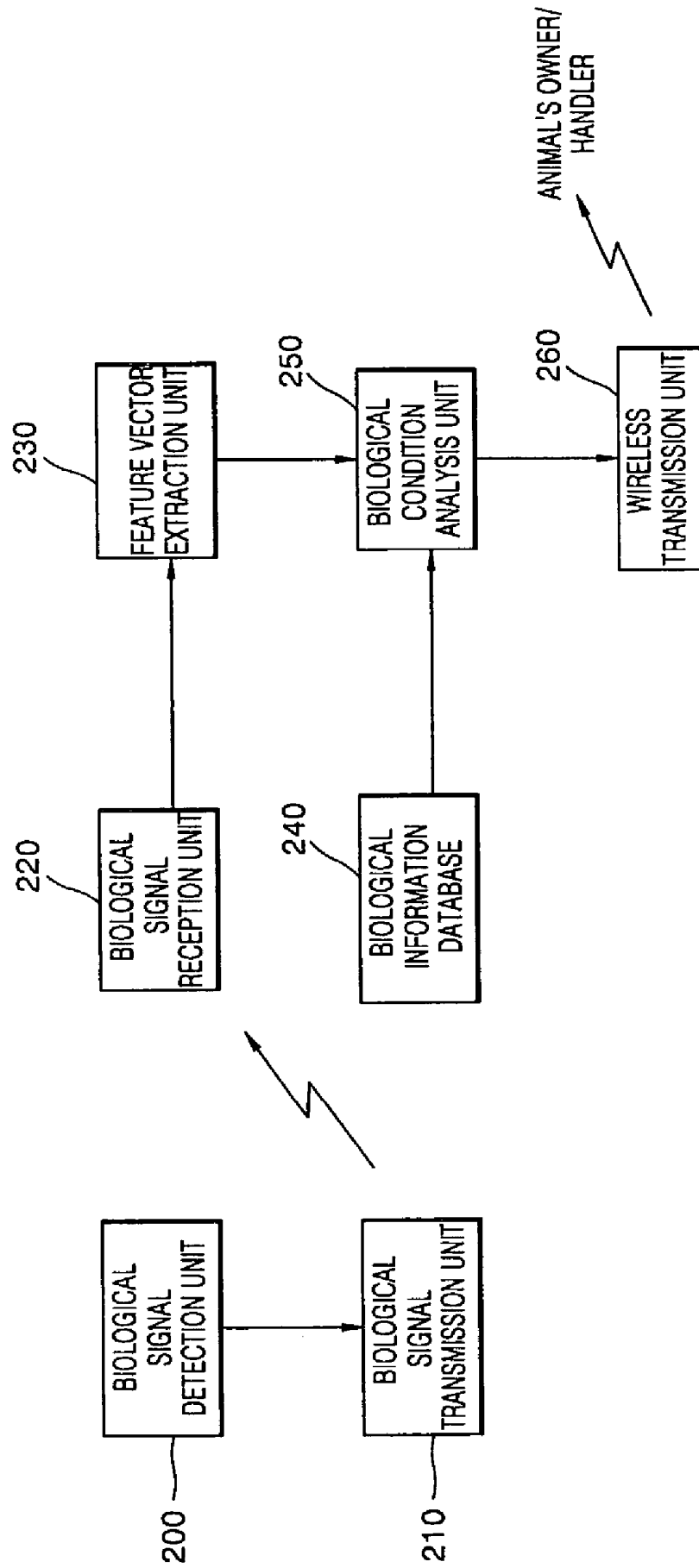

FIG. 3A

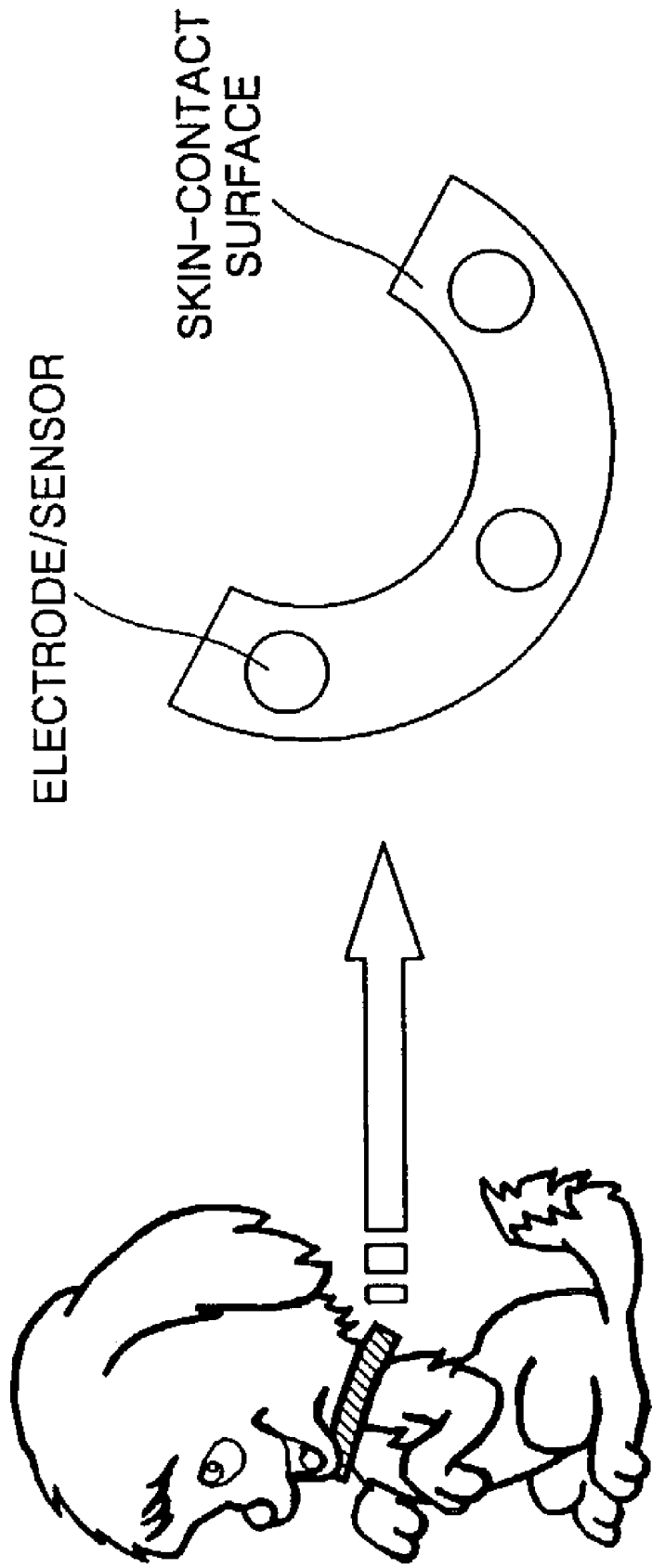

FIG. 3B

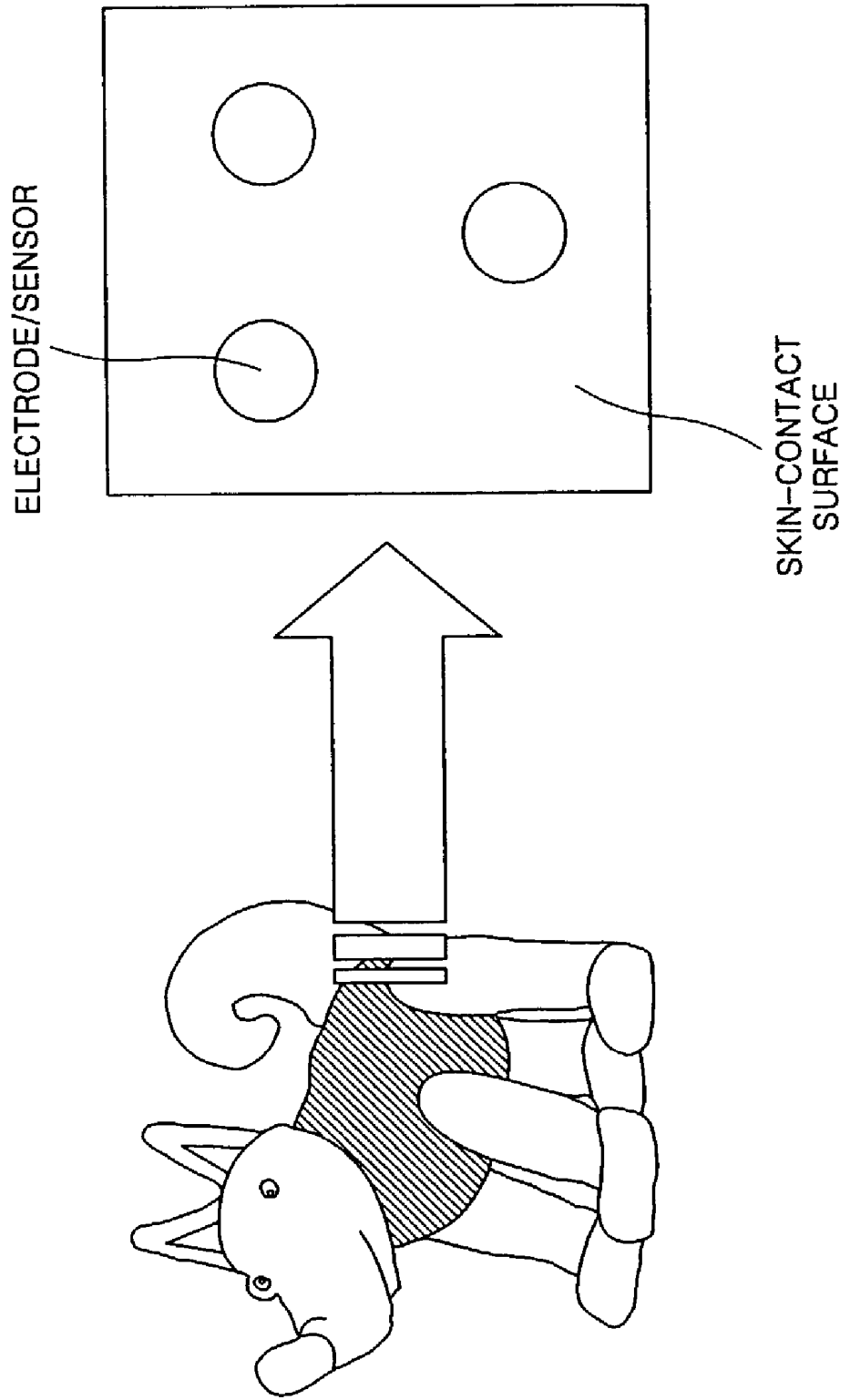

FIG. 4A

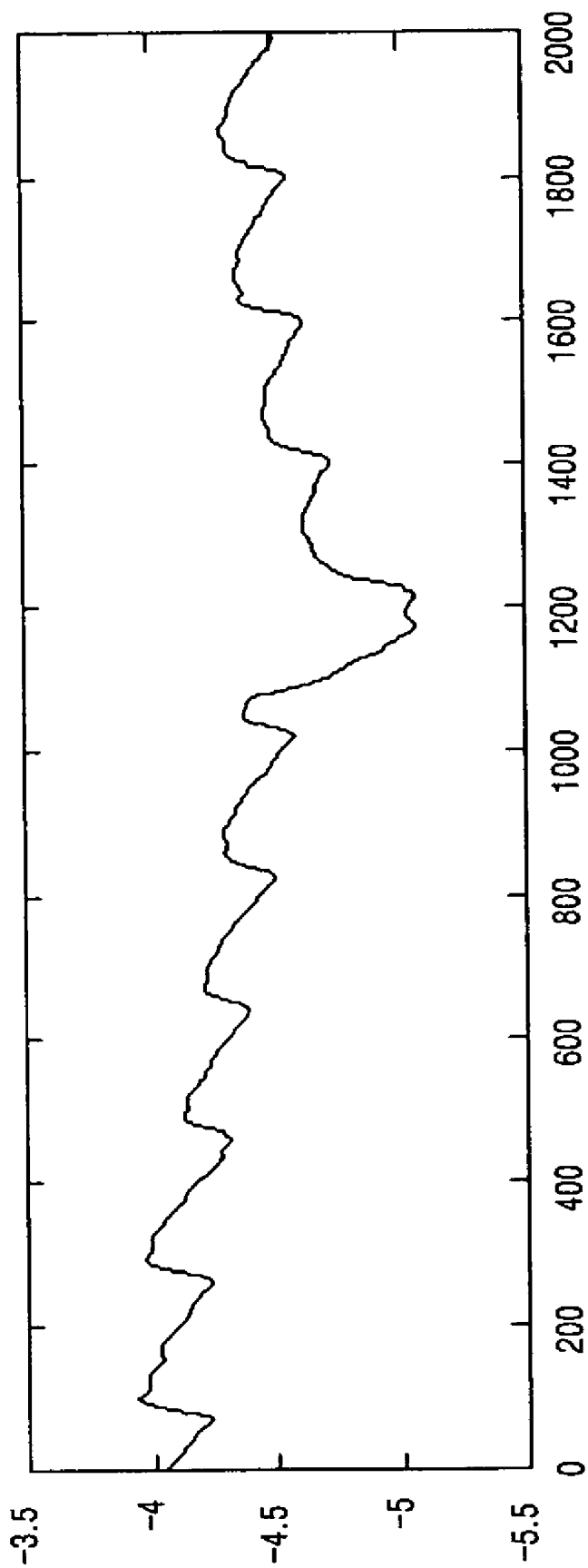

FIG. 4B

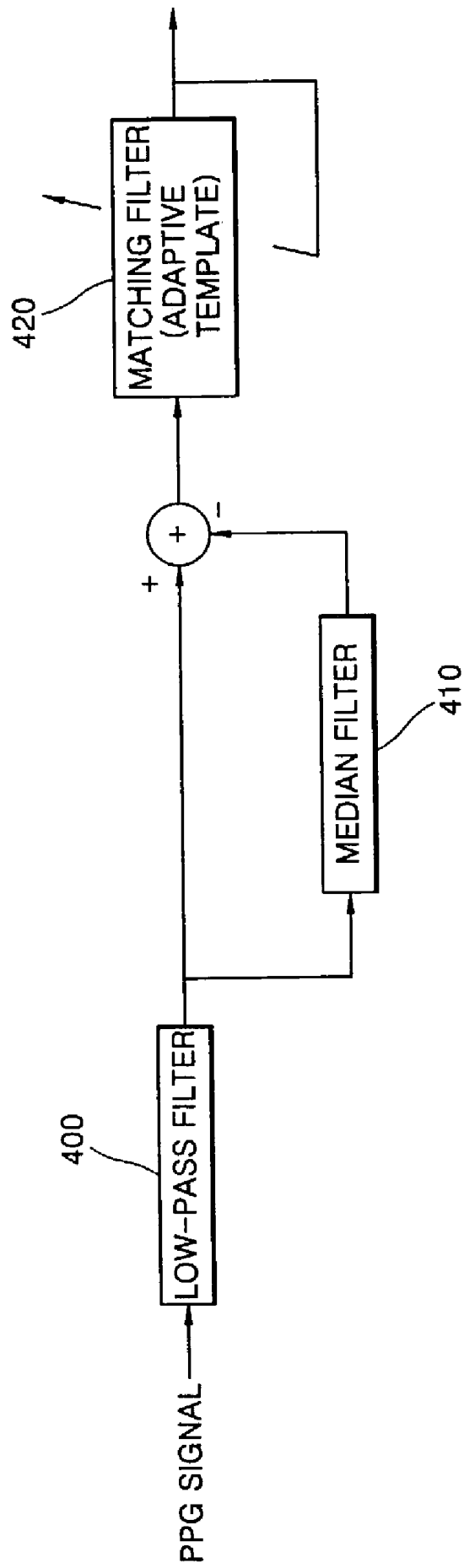

FIG. 5A

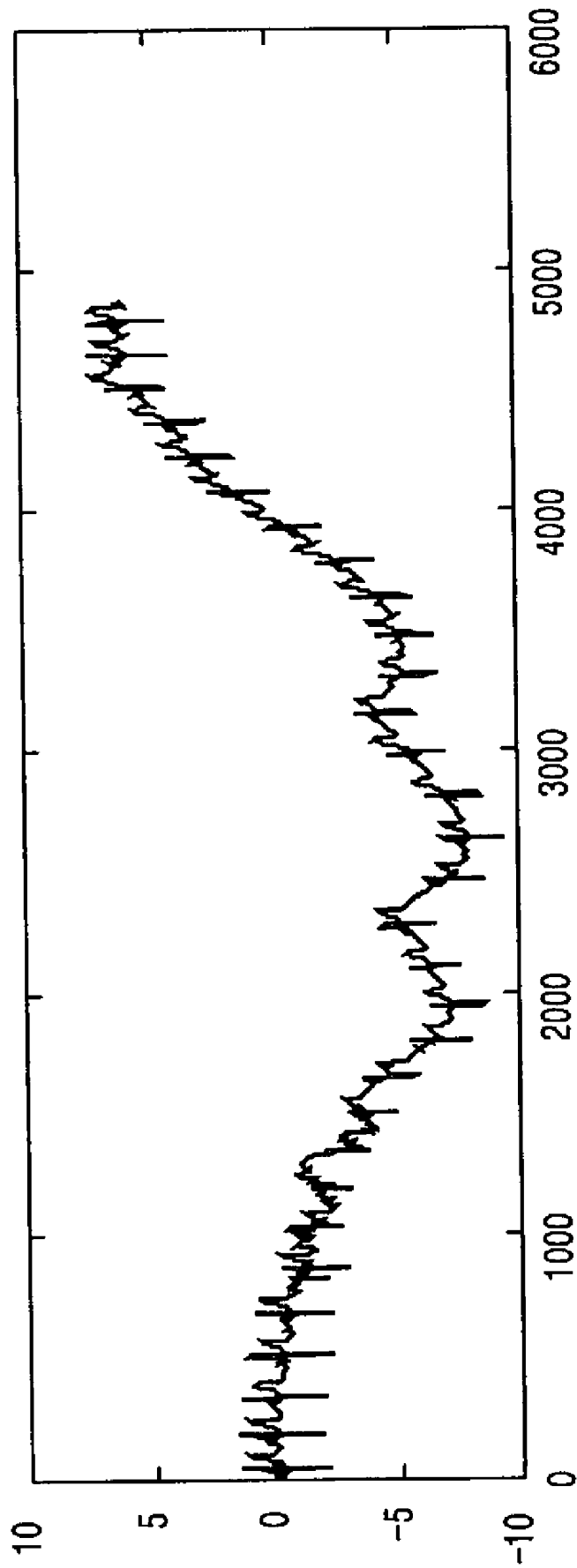

FIG. 5B

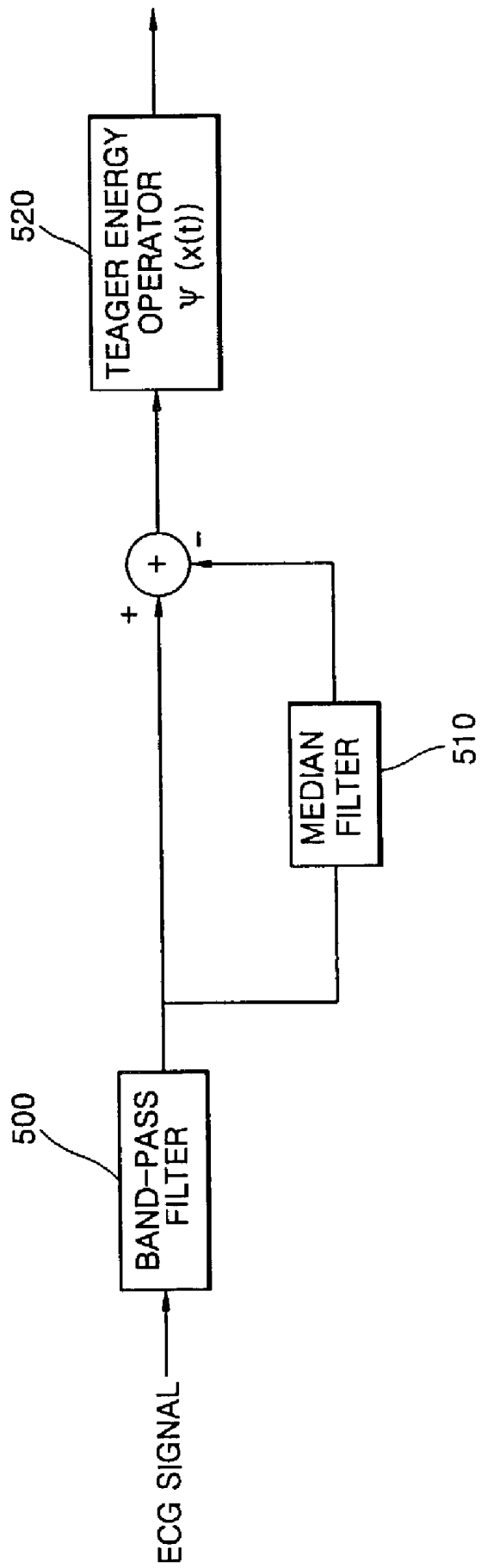

FIG. 5C

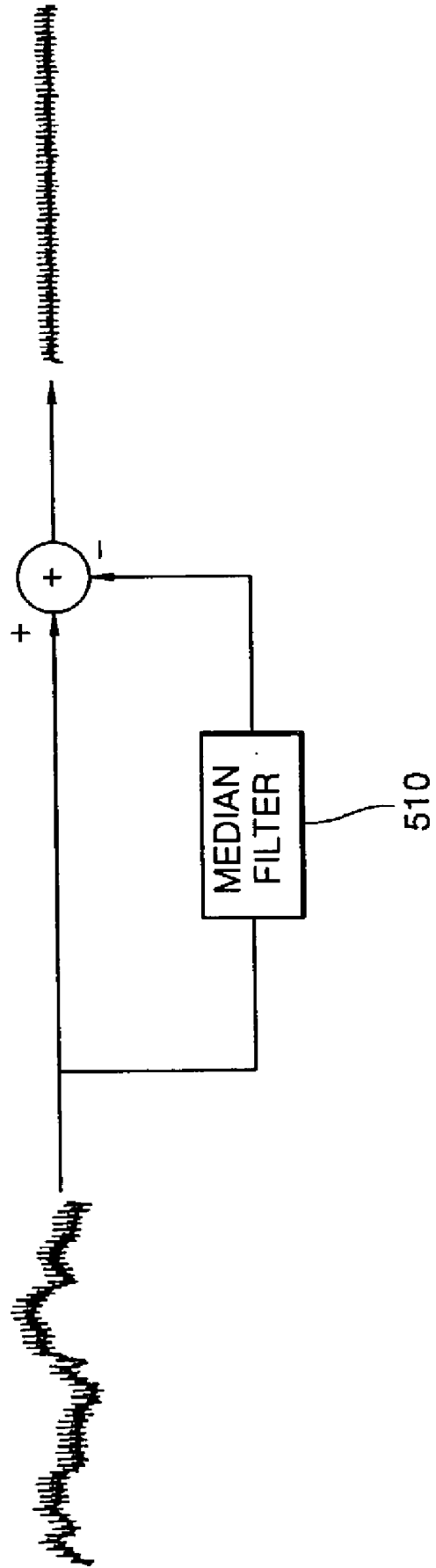

FIG. 5D

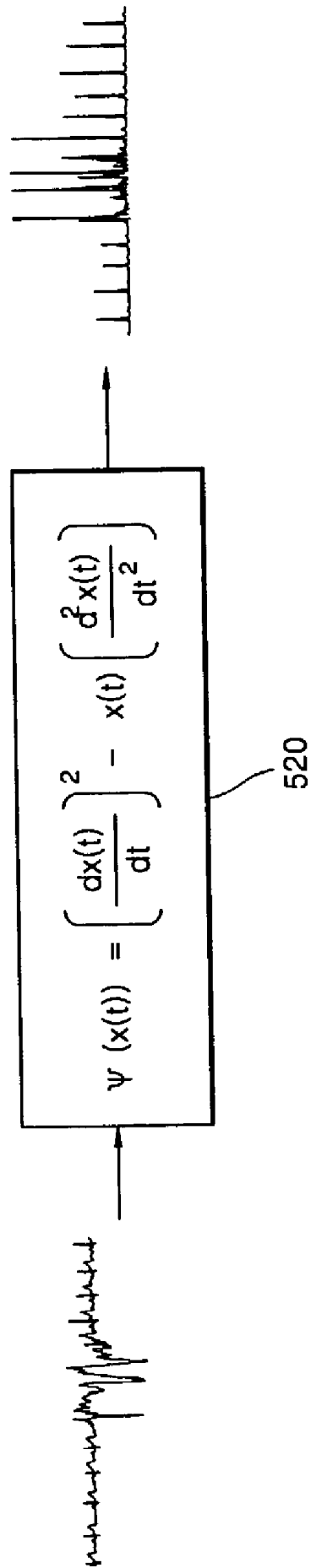

FIG. 6

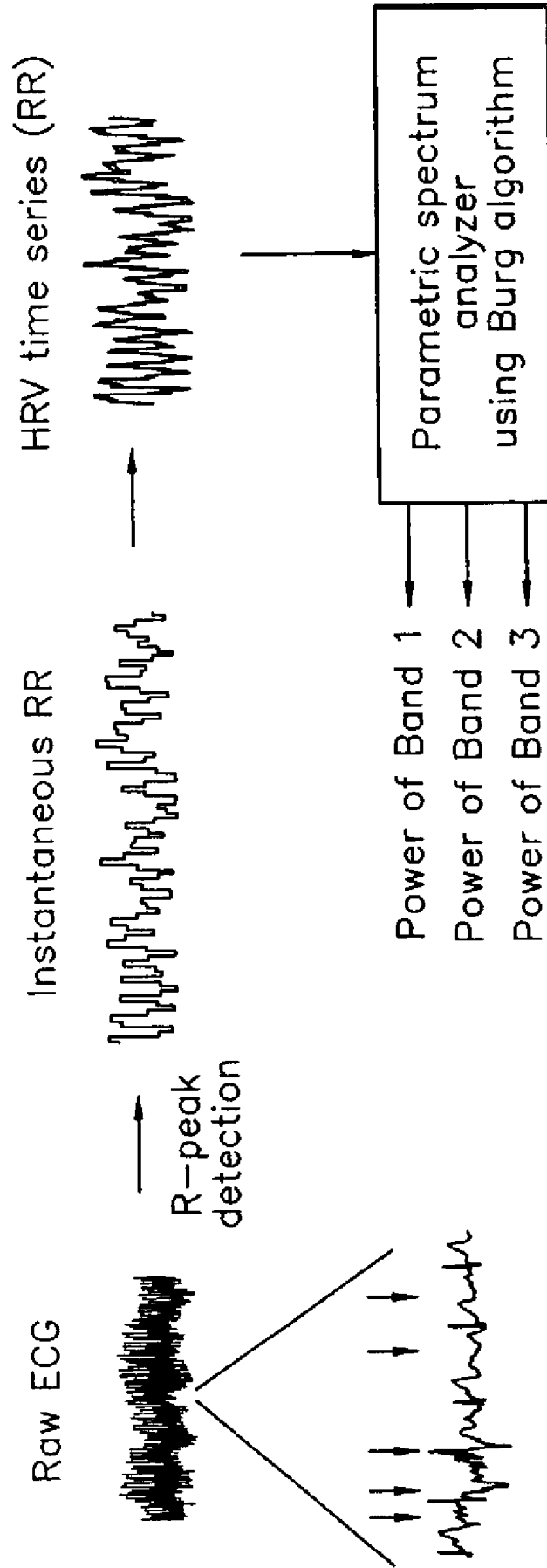

FIG. 7A

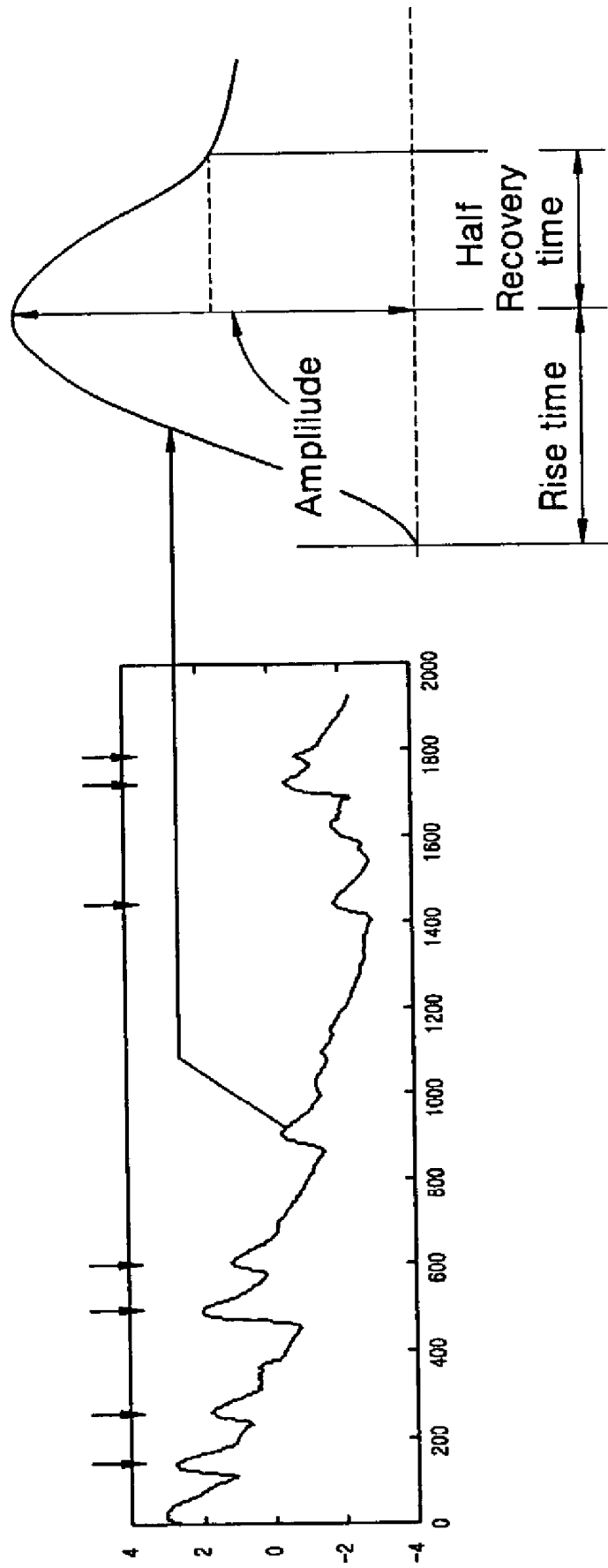

FIG. 7B

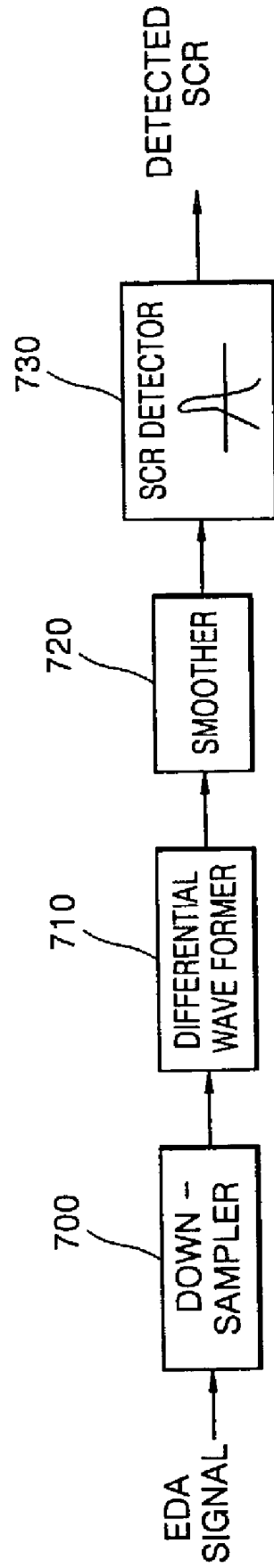

FIG. 8

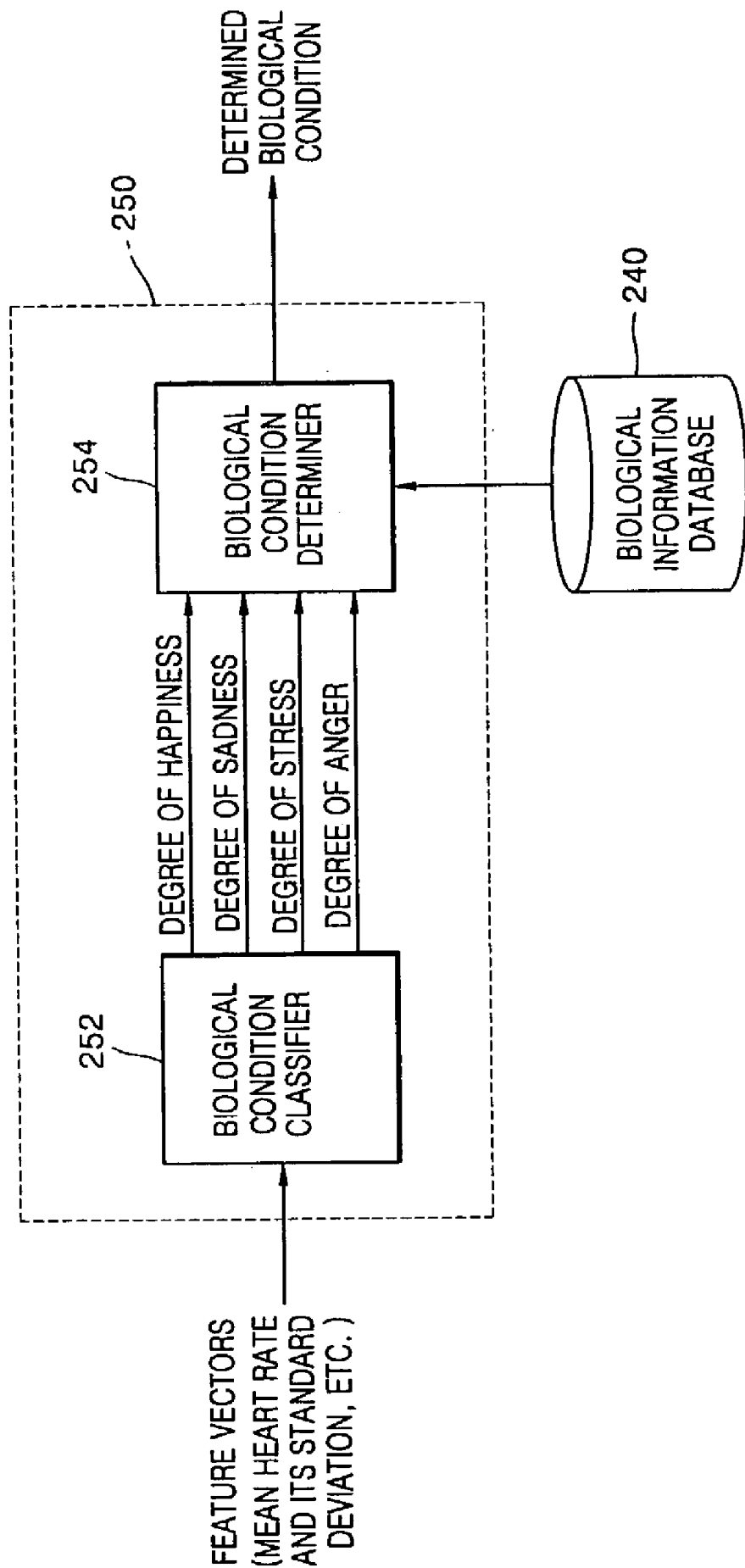

FIG. 9A

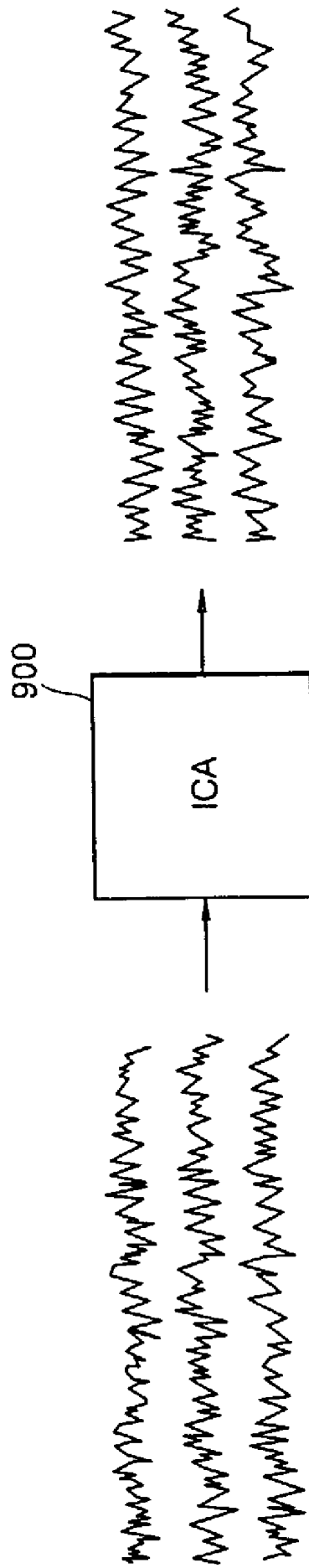

FIG. 9B

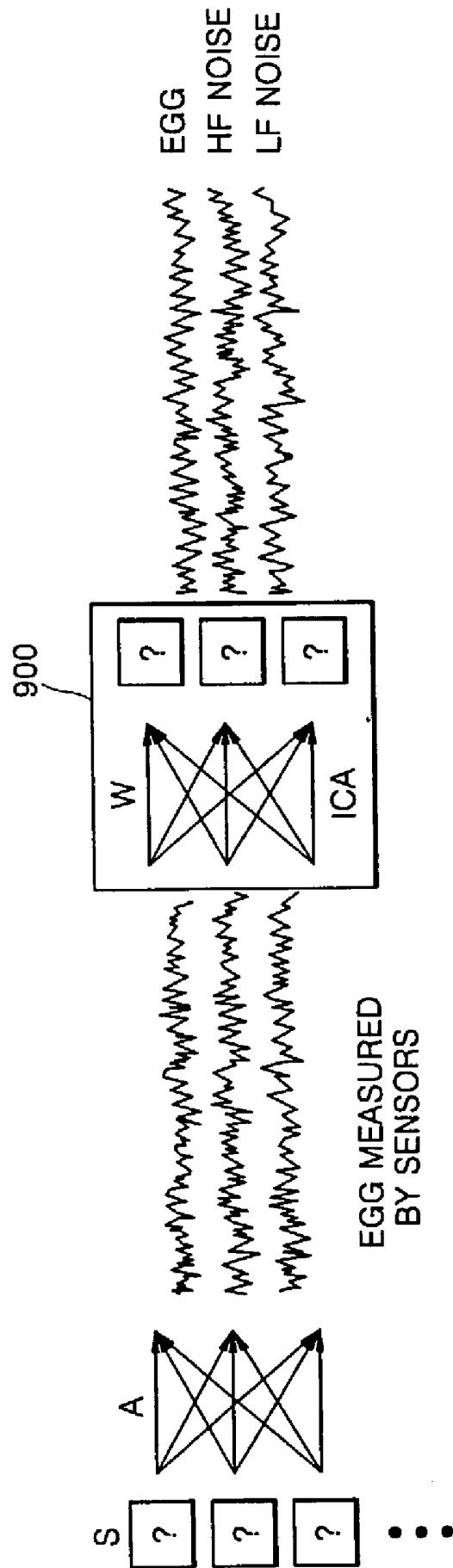

FIG. 10A

EGG WAVEFORMS

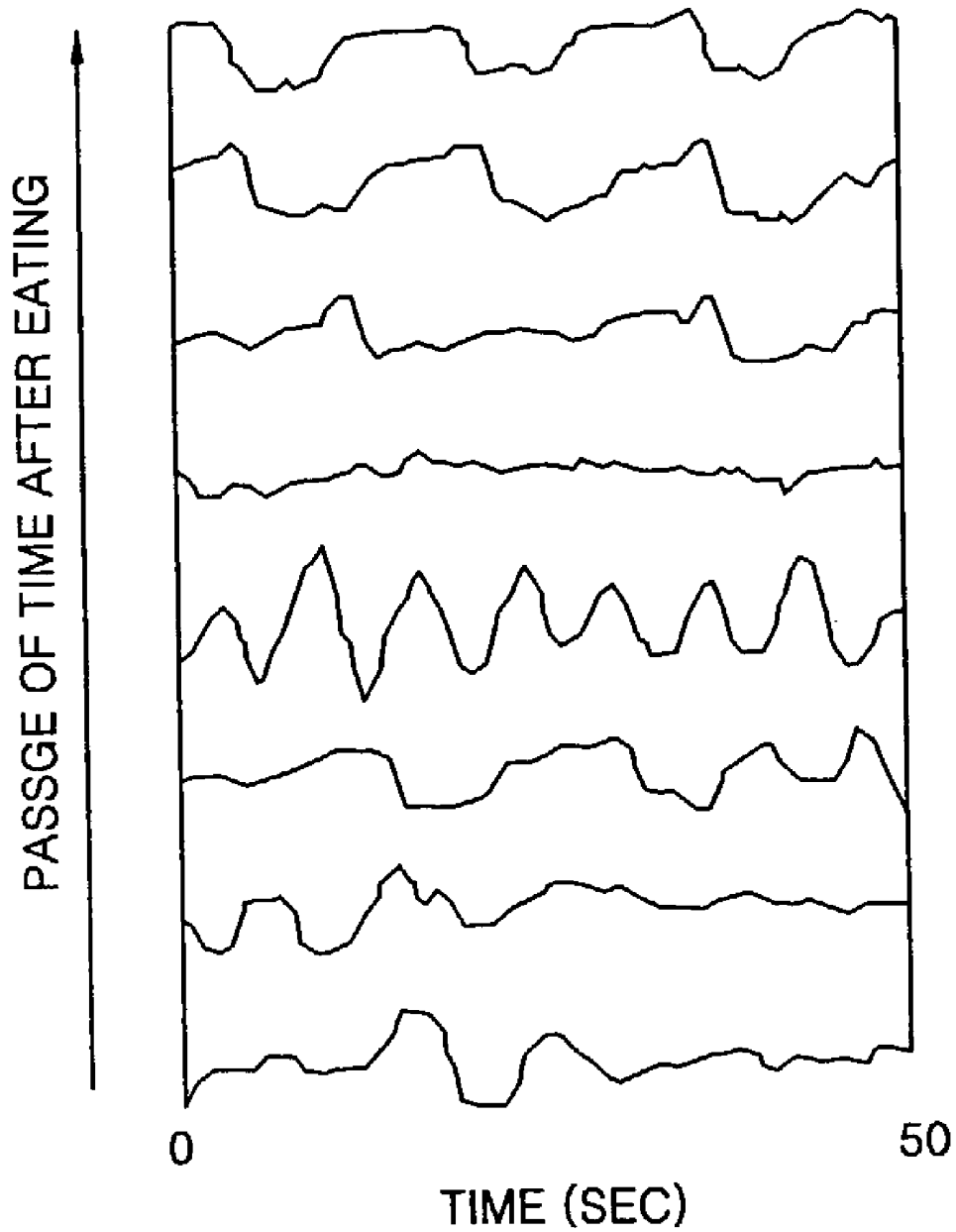

FIG. 10B

SPECTRUM

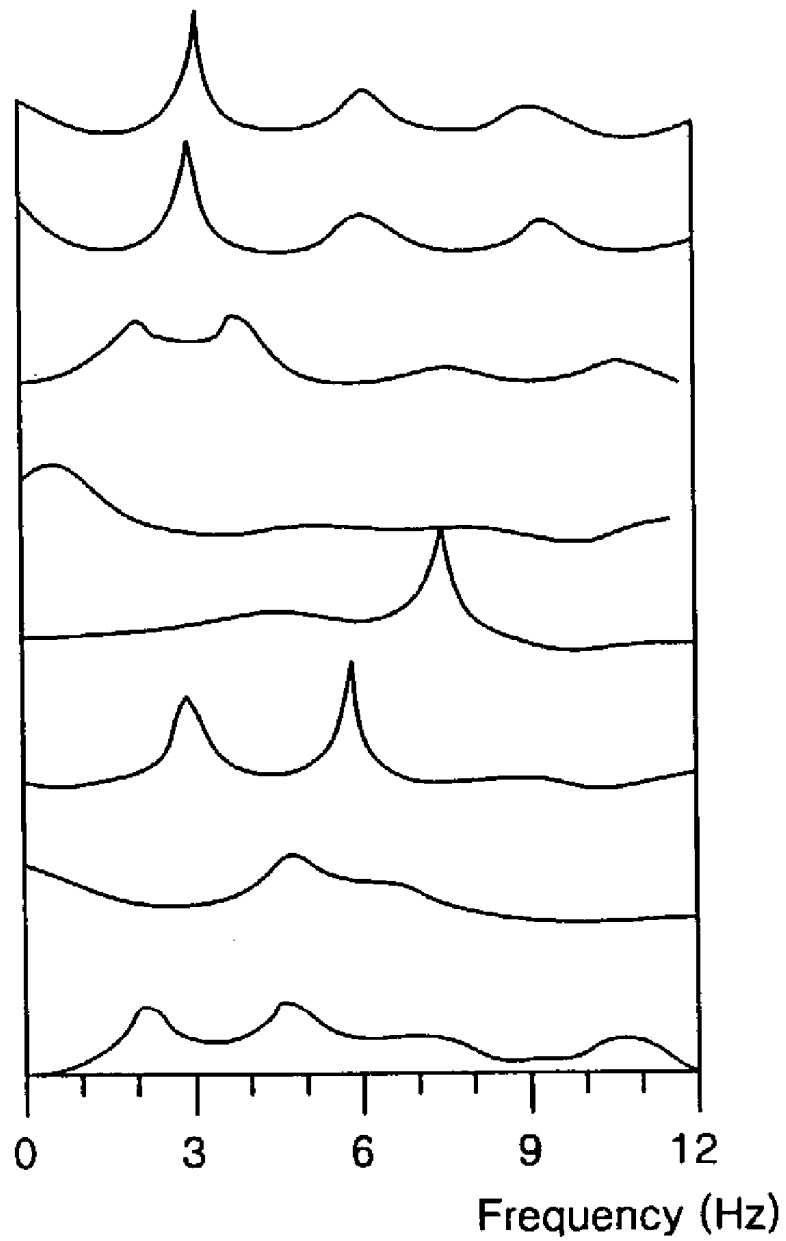

FIG. 11

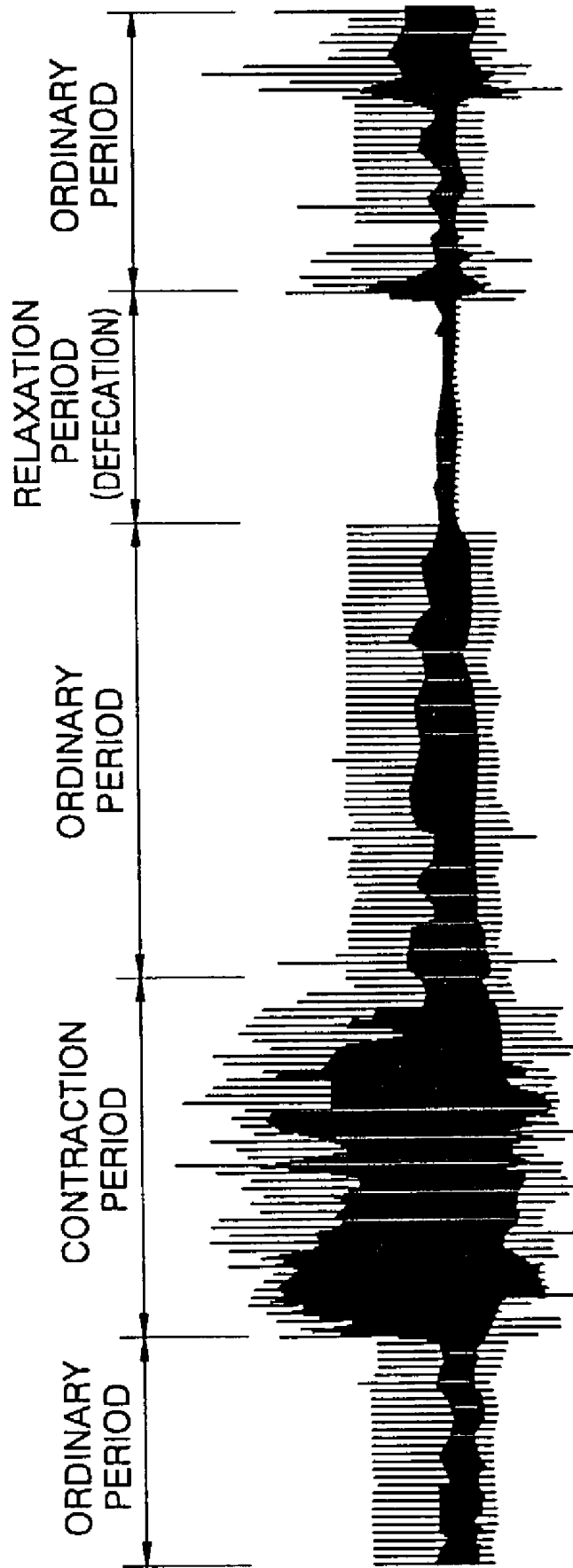
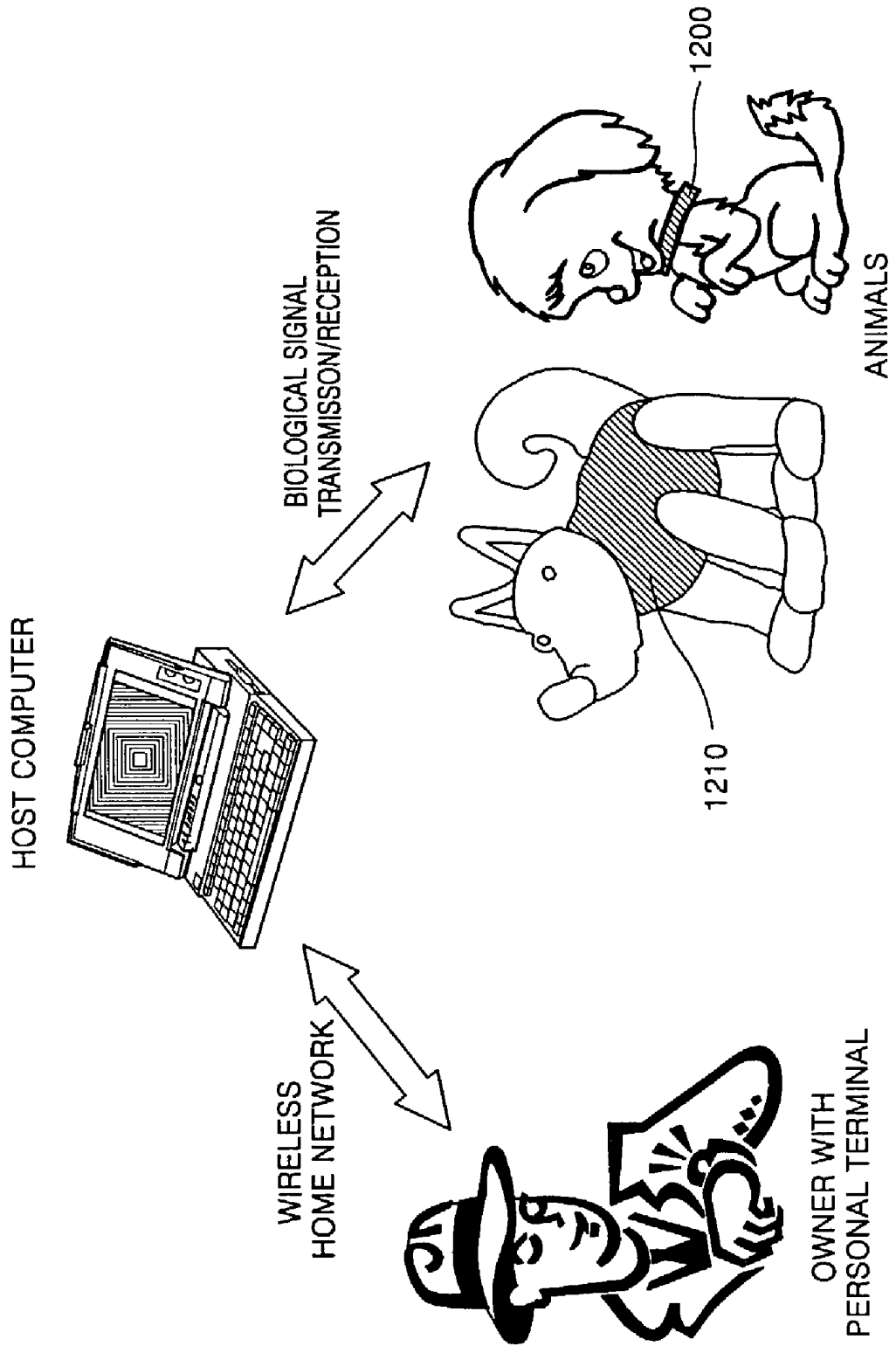

FIG. 12



METHOD AND APPARATUS FOR MEASURING ANIMAL'S CONDITION BY ACQUIRING AND ANALYZING ITS BIOLOGICAL SIGNALS

BACKGROUND OF THE INVENTION

[0001] This application claims priority from Korean Patent Application No. 2002-1696, filed Jan. 11, 2002 in the Korean Industrial Property Office, which is incorporated herein in its entirety by reference.

[0002] 1. Field of the Invention

[0003] The present invention relates to processing a biological signal, and more particularly, to a method and apparatus for measuring an animal's emotional condition and needs by acquiring and analyzing biological signals of an animal, which enable animal-to-human communications.

[0004] 2. Description of the Related Art

[0005] The breeding of pets continues to increase worldwide. Reportedly, about two million pets are bred in South Korea alone, forming a two hundred billion won pet related market.

[0006] Since it is absolutely impossible to communicate with animals using human languages, pet owners yearn to know the mental and physical condition of his/her pet(s). Attempts have been made to measure the physical and emotional condition of pets, but no progress has been made.

[0007] Korean Patent Application No. 2000-41437 discloses a remote pet breeding method via the Internet. In the disclosure, a pet is remotely monitored via the Internet and is fed by clicking on an instruction with a mouse. However, the disclosure is far removed from the measurement of the pet's physical and emotional state.

[0008] Japanese Laid-open Patent Application No. 2001-28961 discloses a pet monitoring and feeding system to be used when the pet's owner is away. According to the disclosure, the location of a pet can be traced by attaching an RF tag to the pet, and the point of time for feeding and giving water the pet is controlled by a timer. However, this disclosure seems to be unrelated to informing the pet owner of the state of his/her pet.

[0009] Japanese Laid-open Patent Application No. 2001-3479 discloses an animal's intention translation method. An animal's sound or motion is transmitted to an animal's intention interpretative system and compared with previously stored reference data. A reference data corresponding to the animal's sound or motion is selected, and the animal's intention is translated based on the selected data in a human language so as to inform the owner of his/her animal's intention. However, the disclosure is not fully described such as to implement the method, for example, how to interpret the animal's sound and how to read the animal's intention from an image signal of an animal's motion. Accordingly, it seems impossible to understand the animal's intention or emotional state using the disclosed method.

[0010] U.S. Pat. No. 5,046,453 discloses an animal training apparatus. According to the disclosure, when a dog barks or does not behave in a trained way, a command signal is wirelessly transmitted to a receiver attached to its collar, in order to flow a cold fluid so as to stop the unexpected behavior of the dog. U.S. Pat. No. 5,054,428 discloses a

method and apparatus for remote conditioned cue control of animal training stimulus. In the disclosure, when a trained dog behaves in an unexpected way, an electrical stimulus signal is applied to the dog for a short duration to call the dog's attention, and the intensity of the electrical stimulus signal is gradually increased when calling the dog's attention is unsuccessful. However, both U.S. applications described above seem to be unrelated to understanding the mental and physical state of animals.

[0011] PCT Patent Publication No. WO99/42968 discloses a pet locator system, which controls the location of a movable object, such as a pet, and informs a user when the movable object does not reach a specific place on time. PCT Patent Publication No. 96/30882 discloses a wireless pet containment system for keeping a pet within a space using a wireless transceiver. These two disclosures are not related to understanding the physical and mental state of animals.

[0012] As described above, conventionally, owners of trainers of pets of animals cannot be aware of the physical or mental state of the pets or animals, which cannot communicate with people using human languages.

SUMMARY OF THE INVENTION

[0013] Accordingly, the invention provides a method and apparatus for measuring animal's biological condition by acquiring and analyzing its biological signals.

[0014] In one aspect, the invention provides a method for determining the biological condition of an animal by acquiring and analyzing a biological signal, the method comprising: (a) acquiring a predetermined biological signal using a biological signal detection unit which is attached to the animal; (b) extracting a predetermined feature vector from the acquired predetermined biological signal; and (c) analyzing and determining the biological condition of the animal, including emotions and needs of the animal, from the predetermined feature vector.

[0015] In another aspect, the invention provides a method for determining the biological condition of an animal by acquiring and analyzing biological signals, the method comprising: (a) acquiring biological signals from skin temperature, a photoplethysmogram (PPG), an electrocardiogram (ECG), electrodermal activity (EDA), an electromyogram (EMG), and an electrogastrogram (EGG) using a biological signal detection unit which is attached to the animal's skin; (b) extracting feature vectors from the acquired biological signals, the feature vectors including the mean heart rate of the photoplethysmogram and its standard deviation, the very low frequency, low frequency, and high frequency components of heart rate variability, the frequency and mean amplitude of skin conductance responses which are obtainable from the electrodermal activity, and the mean and maximum skin temperatures; and (c) analyzing and determining the biological condition, including needs and emotions, of the animal as to whether or not the animal feels hunger or fear, how much the animal is stressed, or whether or not the animal needs to have a bowel movement, using a support vector machine which has learned reference vectors, which reflect the behaviors, needs, and emotions of different kinds of animals for various biological conditions and are stored in a predetermined database.

[0016] In another aspect, the invention provides an apparatus for measuring the biological condition of an animal by

acquiring and analysing biological signals, the apparatus comprising: a biological signal detection unit which is attached to the animal's skin and detects a biological signal of the animal; and a condition analysis unit which determines the biological condition, including needs and emotions, of the animal using a predetermined feature vector extracted by analysing the biological signal detected by the biological signal detection unit.

[0017] In another aspect, the invention provides an apparatus for measuring the biological condition of an animal by acquiring and analysing biological signals, the apparatus comprising: a biological signal detection unit including a plurality of sensors and electrodes, which is attached to the animal's skin and detects biological signals from skin temperature, an electrocardiogram (ECG), a photoplethysmogram (PPG), electrodermal activity (EDA), an electromyogram (EMG), and an electrogastrogram (EGG); a feature vector extraction unit which extracts feature vectors from the biological signals detected by the biological signal detection unit, the feature vectors including the mean heart rate of the photoplethysmogram and its standard deviation, the very low frequency, low frequency, and high frequency components of heart rate variability, the frequency and mean amplitude of skin conductance responses, and the mean and maximum skin temperatures; a biological information database which stores reference vectors reflecting the behaviors, needs, and emotions of different kinds of animals for various biological conditions; and a biological condition analysis unit which compares the feature vectors extracted by the feature vector extraction unit with reference vectors of the biological information database and determines the biological condition, including needs and emotions, of the animal as to whether or not the animal feels hunger or fear, how much the animal is stressed, or whether or not the animal needs to have a bowel movement.

BRIEF DESCRIPTION OF THE DRAWINGS

[0018] The above features and advantages of the present invention will become more apparent by describing in detail exemplary embodiments thereof with reference to the attached drawings in which:

[0019] **FIG. 1** is a flowchart of a method for measuring the biological condition of an animal by acquiring and analysing its biological signals, according to the present invention;

[0020] **FIG. 2** is a block diagram of an apparatus for performing the method of **FIG. 1** for measuring the biological condition of an animal by acquiring and analysing its biological signals;

[0021] **FIGS. 3A and 3B** show a collar type sensor module and a wearable sensor module, respectively, attached to the animal as a biological signal detection unit according to the present invention;

[0022] **FIG. 4A** shows an example of a photoplethysmogram (PPG);

[0023] **FIG. 4B** is a block diagram of an example of a PPG signal processor;

[0024] **FIG. 5A** shows an electrocardiogram (ECG) waveform of an animal measured using a two-electrode or three-electrode method;

[0025] **FIGS. 5B through 5D** are block diagrams of an embodiment of an ECG signal processor according to the present invention for detecting R-peaks of the ECG;

[0026] **FIG. 6** illustrates a process for calculating the power of particular frequency bands from time-series heart rate variability through autoregressive modelling using the Burg algorithm;

[0027] **FIG. 7A** shows an example of an electrodermal activity (EDA) waveform obtained using the sensor module of **FIG. 3A** or **3B** as the biological signal detection unit attached to the animal's body;

[0028] **FIG. 7B** is a block diagram of an embodiment of an apparatus for detecting skin conductance responses, which can be used in extracting feature vectors, from an EDA signal according to the present invention;

[0029] **FIG. 8** is a detailed block diagram of a biological condition analysis unit according to the present invention;

[0030] **FIG. 9A** shows raw electrogastrographic (EGG) waveforms and EGG waveforms after pre-processing by independent component analysis (ICA);

[0031] **FIG. 9B** illustrates EGG waveforms sensed from unknown sources by sensors of the biological signal detection unit, which includes noise, and EGG waveforms from which the noise is removed by ICA;

[0032] **FIG. 10A** shows EGG waveforms after pre-processing;

[0033] **FIG. 10B** shows a time-varying spectrum obtained using the EGG waveforms of **FIG. 10A**;

[0034] **FIG. 11** shows an example of an electromyographic (EMG) waveform related to bowel movement; and

[0035] **FIG. 12** illustrates a system for measuring the biological condition of an animal, which is constructed of a collar type sensor module or a wearable sensor module and contacts the animal's body, a host computer which determines the biological condition of the animal by receiving and processing biological signals, and a wireless personal terminal which receives the result of the animal's determined biological condition.

DETAILED DESCRIPTION OF THE INVENTION

[0036] **FIG. 1** is a flowchart for illustrating a method for measuring the biological condition of an animal by acquiring and analysing its biological signals, according to the present invention. Biological signals of an animal are acquired by determining the animal's skin temperature (SKT), electrocardiogram (ECG) reading, photoplethysmogram (PPG) reading, electrodermal activity (EDA), electromyogram (EMG) reading, and electrogastrogram (EGG) reading using a biological signal detection unit attached to the animal's skin, and the acquired biological signals are transmitted (step 100). The transmitted biological signals are received, and predetermined feature vectors are extracted from the received biological signals (step 110). Next, the biological condition of the animal, as to whether it feels hunger or fear, how much it is stressed, or whether or not it has a bowel movement need, is measured in step 120 using the feature vectors. Reference vectors which reflect the behaviors, needs, and emotions of different kinds of animals

for various biological conditions and which previously stored in a predetermined database are compared with the extracted feature vectors in order to measure the animal's biological condition as to whether it feels hungry or fear, how much it is stressed, or whether or not it has a bowel movement need.

[0037] Next, the animal's owner is informed of the measured biological condition of his/her animal via a predetermined communication unit in step 130.

[0038] When the animal's owner wishes to provide an expert, such as a veterinarian, with the information on the biological condition of his/her animal, the biological signals obtained in step 100 or the biological condition measured in step 120 are transmitted to the expert via a predetermined communication unit, such as a wireless communication unit. In this case, it is preferable that the animal's owner be informed of the result of a diagnosis performed by the expert based on the biological signals and the measured biological condition via a predetermined communication unit.

[0039] FIG. 2 is a block diagram of an apparatus for performing the method of FIG. 1 for measuring the biological condition of an animal by acquiring and analyzing its biological signals. The apparatus of FIG. 2 includes a biological signal detection unit 200 including a plurality of sensors and electrodes, which is attached to the animal's skin so as to detect the animal's biological signals, a biological signal transmission unit 210 which wirelessly transmits the biological signals, as detected by the biological signal detection unit 200, using a predetermined method, a biological signal reception unit 220 which receives the transmitted biological signals, and a feature vector extraction unit 230 which extracts feature vectors indicative of the animal's biological condition, including the mean heart rate and its standard deviation, the very low frequency (VLF), low frequency (LF), and high frequency (HF) components of the ECG, the frequency and mean amplitude of skin conductance responses, and the mean and maximum skin temperatures. The apparatus of FIG. 2 includes a biological information database 240 which stores reference vectors, which reflect the behaviors, needs, and emotions of different kinds of animals for various biological conditions, and a biological condition analysis unit 250 which analyzes the animal's biological condition as to whether it feels hunger or fear, how much it is stressed, or whether or not it has a bowel movement need, by comparing the feature vectors extracted by the feature vector extraction unit 230 with the reference vectors.

[0040] Preferably, the biological condition measuring apparatus of FIG. 2 further includes a wireless transmission unit 260 which wirelessly transmits the biological condition of the animal, as measured by the biological condition analysis unit 250, to the owner of the animal.

[0041] The biological signals detected by the biological signal detection unit 200 or the animal's biological condition measured by the biological condition analysis unit 250 can be transmitted to an expert, such as a veterinarian, via the wireless transmission unit 260, for diagnostic purposes.

[0042] Embodiments of the present invention will be described in detail based on the method of FIG. 1 and the structure of FIG. 2.

[0043] Human beings communicate with one another mostly through dialogues. Accordingly, new technologies of

human-computer interaction (HCI) for conveying human intentions to artificial electronic systems, such as computers or robots, have been developed based on voice-related techniques, such as speed recognition and voice synthesis.

[0044] Human beings have also communicated partially with pets, such as dogs or cats, which are on intimate terms with their owners, from his/her pet's groans or particular gestures.

[0045] According to the present invention, biological signals which reflect a pet's needs and emotional condition are detected using a sensor module attached to the animal's skin as the biological logical condition detection unit and are wirelessly transmitted so as to be processed by a processor using a predetermined signal processing method and pattern recognition, so that the physical and mental conditions of the pet can be measured. Next, information on the pet's physical and mental conditions is transferred to an expert, such as a veterinarian.

[0046] Like human beings, an animals' emotional condition affects its autonomic nervous system (sympathetic and parasympathetic nervous systems), and thus biological signals reflect the condition of the autonomic nervous system, i.e., related to heart rate variability, electrodermal activity, skin temperature, etc. Also, an animal's need for a bowel movement or its feeling of hunger can be reflected in the biological signals of the EMG and EGG. By continuously detecting appropriate biological signals among various biological signals, which indicate the biological condition of the animal, and appropriately processing and interpreting the detected biological signals, information on the animal's emotional condition or its needs can be extrapolated.

[0047] FIGS. 3A and 3B illustrate examples of the sensor module attached to animals and serving as the biological signal detection unit according to the present invention. FIG. 3A shows a collar type sensor module, and FIG. 3B shows a wearable sensor module. Sensors and electrodes are attached to the inner surface of the sensor module to contact the animal's skin.

[0048] It is preferable that the sensor module serving as the biological signal detection unit 200 be configured to continuously detect biological signals of the pet without discomforting the pet. To this end, the sensor module can be implemented as a collar type or a wearable type, as shown in FIGS. 3A and 3B, respectively, with electrodes and sensors attached on a rigid support. In this case, the electrodes and sensors must directly contact the skin of the neck or abdomen of the animal.

[0049] Biological signals are acquired from the SKT, ECG, PPG, EDA, EMG, and EGG using the sensors/electrodes of the biological signal detection unit 200 attached to the animal's skin (Step 100). The acquired biological signals are processed by a preamplifier, a filter, a main amplifier, etc, subjected to time divisional multiplexing, analog-to-digital conversion, and modulation, and wirelessly transmitted via an RF transmitter. Those processes are performed in the biological signal transmission unit 210.

[0050] The biological signal reception unit 220 receives the biological signals transmitted from the biological signal transmission unit 210 via an RF receiver and restores the original biological signals through a series of processes, such as demodulation, signal recovery, etc. The restored

biological signals can be analog signals which are detected by the biological signal detection unit **200** or digital signals. However, it is preferable that the restored biological signals be digital signals in the following case.

[**0051**] The restored biological signals are transmitted to the feature vector extraction unit **230** so as to extract feature vectors indicating the biological condition of the animal. The feature vector extraction unit **230** can be implemented using hardware, for example, as an add-on card, in a computer system. Alternatively, the feature vector extraction unit **230** can be implemented in hardware, such as a computer system, using software.

[**0052**] Hereinafter, the operation and function of the feature vector extraction unit **230** will be described. When the sympathetic or parasympathetic nervous systems of the animal are stimulated due to an emotional change, the stimulation is transferred to the sinoatrial (SA) node acting as a cardiac pacemaker and varies the heart rate in a particular pattern. The heart rate pattern varies with emotional changes. The heart rate of pets can be measured by a variety of methods, for example, by electrocardiography (ECG), phonocardiography, photoplethysmography (PPG), etc.

[**0053**] When a collar type sensor module as shown in **FIG. 3A** is used as the biological signal detection unit **200**, a PPG is measured from the carotid, and the heart rate is measured using the alternating current (AC) signal of the PPG. As a result, heart rate variability can be measured. A method for constructing a photoplethysmographic sensor module is described in "Medical Instrumentation" (J. G. Webster, 1999).

[**0054**] Alternatively, when a sensor module as shown in **FIG. 3B** is used, an ECG can be obtained using a two-electrode or three-electrode method.

[**0055**] An example of the PPG described above is shown in **FIG. 4A**. **FIG. 4B** is a block diagram of an example of a PPG signal processor according to the present invention.

[**0056**] Referring to **FIG. 4B**, a PPG signal is passed through a low-pass filter **400** to remove high-frequency noise. The PPG signal output from the low-pass filter **400** is passed through a median filter **410** to estimate a very low frequency baseline variation. The very low frequency baseline variation is subtracted from the low-pass filtered PPG signal in order to obtain a waveform, from which the very low frequency baseline variation and direct current and high frequency components are removed. The resulting signal is passed through a matching filter to read PPG peaks. Heart rate and heart rate variability are measured using the PPG peaks.

[**0057**] **FIG. 5A** shows an ECG of an animal obtained using the two-electrode or three-electrode method. **FIGS. 5B through 5D** are block diagrams of an embodiment of an ECG signal processor according to the present invention, for detecting R-peaks from an ECG signal in order to determine the instant the heart beat.

[**0058**] In particular, **FIG. 5B** is an overall block diagram of the ECG signal processor, which performs a time series analysis of heart rate variability by processing an ECG signal. The ECG signal of **FIG. 5A** is passed through a band-pass filter **500** to remove background noise that does

not belong to the QRS complex frequency band. The ECG signal from the band-pass filter **500** is passed through a median filter **510** to estimate a baseline variation. The baseline variation is subtracted from the band-pass filtered ECG signal in order to obtain a waveform from which the baseline variation and background noise are removed. **FIG. 5C** illustrates an input and an output of the median filter **510** so as to visualize the function of the median filter **510**.

[**0059**] The signal output from the median filter **510** is applied to a Teager energy operator (TEO) **520** ("Neural spike sorting under nearly 0 dB signal-to-noise ratio using non-linear energy operation and artificial neural network classifier, *Kyung Hwan Kim* et al., IEEE Transactions on Biomedical Engineering, 2000) in order to detect R-peaks in which the amplitude and frequency abruptly rise and to measure time-series heart rate variability from the intervals of the R-peaks.

[**0060**] **FIG. 5D** illustrates an input, an output, and the operating function of the TEO **520** to explain the function of the TEO **520**.

[**0061**] After detecting heart beats, time-series heart rate variability is measured through smoothing and down-sampling. This process is widely known to those of ordinary skill in the art and can be easily implemented by such people ("An efficient algorithm for spectral analysis of heart rate variability", R. D. Berger et al., IEEE Trans. Biomed. Eng., Vol. 33).

[**0062**] **FIG. 6** illustrates a process for calculating the power of particular frequency bands from the time-series heart rate variability through autoregressive modelling using the Burg algorithm.

[**0063**] Through the autoregressive modelling using the Burg algorithm, the power of three frequency bands, a very low frequency (VLF) band of 0.0043-0.04 Hz, a low frequency (LF) band of 0.04-0.15 Hz, and a high frequency (HF) band of 0.15-0.4 Hz, are calculated from the time-series heart rate variability. The autoregressive modelling using the Burg algorithm is described in "Statistical Digital Signal Processing and Modelling", M. Hayes, Wiley, 1996.

[**0064**] In addition to the frequency domain features, time-domain features, such as the mean heart rate in a time interval or its standard deviation, are used as feature vectors indicating the biological condition of an animal. When the standard deviation is calculated, the heart rates within 10% of the maximum and minimum heart rates are eliminated so as to reduce misdetection of the R-peaks.

[**0065**] **FIG. 7A** shows an example of an EDA waveform obtained using the sensor module of **FIG. 3A** or **3B**. The EDA waveform can be obtained by measuring the voltage difference between two metal electrodes of the sensor module of **FIG. 3A** or **3B** after flowing a small amount of current across the metal electrodes. The EDA waveform reflects the activity of the glandulae sudoriferae that is controlled by the sympathetic nervous system and is mostly influenced by the degree of stimulation and stress.

[**0066**] Parameters reflecting the EDA features in **FIG. 7A** include the mean level of the EDA waveform, the amplitude and duration of feature waveforms, which are called "skin conductance responses (SCRs)", the frequency of SCRs in a

unit period of time, etc. In order to extract those parameters, the SCRs are detected as follows.

[0067] **FIG. 7B** is a block diagram of an embodiment of an apparatus for detecting SCRs, which can be used in extracting feature vectors, from an EDA signal, according to the present invention. Initially, the input EDA waveform has a sampling rate of about 256 Hz. The sampling rate is lowered to $\frac{1}{10}$ -12 by a down-sampler **700**. A differential waveform is obtained by a differential wave former **710**. In a smoother **720**, the differential waveform is smoothed by convolution with a Bartlett window, for example, having a length of 20 ("Statistical Digital Signal Processing and Modelling", M. Hayes, Wiley, 1996). In a SCR detector **730**, two points of the smoothed waveform that intersects a threshold level are taken as the start and end points of an SCR.

[0068] Skin temperature (SKT) can be measured using a small thermal sensor, such as a semiconductor thermal sensor, a thermistor, etc. The mean, maximum, and minimum temperatures in a predetermined time interval, and preferably, the mean and maximum temperature, are used as major parameters.

[0069] The feature vector extraction unit **202** extracts feature waveforms indicative of the animal's biological condition using the sensed biological signals and extracts feature vectors reflecting the animal's current emotional condition related with the autonomic nervous system, as described above.

[0070] According to the present invention, 9 feature vectors, including the mean heart rate and its standard deviation (from which the heart rates within 10% of the upper and lower limits are excluded), the VLF, LF, and HF components of the heart rate variability, the frequency and mean amplitude of SCRs of the EDA, and the mean and maximum skin temperatures, are extracted.

[0071] The biological condition analysis unit **250** receives the feature vectors extracted by the feature vector extraction unit **230** using the biological signals, which indicate the condition of the autonomic nervous system, and compares the feature vectors with reference vector data previously stored in the biological information database **240** so as to select maximum likelihood biological information, which is most likely to match the animal's current condition, among a predetermined number of biological information categories stored in the biological information database **240**. The reference vector data refers to the predetermined number of biological information categories for different kinds of animals that reflect their behaviors, needs, and emotions in various biological conditions. As a result, the physical and mental conditions of animals can be measured.

[0072] Extracting reference information on the animal's emotional conditions from the biological information database **240** and determining which reference information best reflects the feature vectors extracted by the biological condition analysis unit **250** using the biological signals can be achieved using the following principles.

[0073] If the feature vectors reflecting particular emotional conditions form one probability distribution in multi-dimensional space and the probability density function for each of the emotional conditions is known, a statically

optimal classifier can be configured using the Bayes rule (Pattern Classification, 2nd Ed., R. O. Duda, P. E. Hart, and D. G. Stock, 2000, Wiley).

[0074] However, it is practically impossible to obtain accurate probability density functions. For this reason, a multiplayer perceptron, a Parzen window classifier implemented based on significant rules that are equivalent to the Bayes rule, through learning of a limited number of data, etc. are commonly used. However, this type of classifier is highly likely to operate inaccurately when unlearned new data are used. In other words, those classifiers show poor generalization performance. An attempt has been made to eliminate this drawback by Fisher projection, which provides the maximum amount of separation between clusters, among other linear projection techniques. As a result of projecting data distribution of higher dimensions into two dimensions, as can be expected, the variance within each cluster was great, and the degree of overlap of clusters was high. In other words, the sizes of the feature vector clusters were very large, and feature vector clusters of different conditions overlapped considerably. Therefore, the classifier using a limited number of learned data is highly likely to operate inaccurately.

[0075] According to the present invention, support vector machine (SVM) known to provide better generalization performance than the two above-described methods is used as a classifier. The SVM is implemented based on the fact that linear mapping into higher dimensions can increase the probability of linear separation and using a Vapnik statistical learning theory-based method for configuring a linear classifier having optimal generalization performance.

[0076] Parameters that define the learning rule in the classifier are determined by establishing a higher dimensional linear classifier equation capable of minimizing classification errors and maximizing generalization performance using given learned data. Based on the solutions of this equation, a linear mapping method for mapping the original dimension into a higher dimension can be realized.

[0077] A detailed description on the SVM will not be provided here (V. Vapnik, "An Overview of Statistical Learning Theory", IEEE Transactions on neural network, Vol. 10, No. 5, pp. 988-999, 1999).

[0078] **FIG. 8** is a detailed block diagram of the biological condition analysis unit **250** according to the present invention. A biological condition classifier **252** classifies the feature vectors extracted by the feature vector extraction unit **230**, according to biological condition categories using the above describe SVM, for example, degree of happiness, degree of sadness, degree of stress, degree of anger, degree of tension, and degree of fear, etc. In a biological condition determiner **254**, the biological condition categories of the animal are compared with the reference vector data on the basic biological conditions of animals stored in the biological information database **240** in order to determine the final biological condition of the animal, and the result of the determination is output.

[0079] **FIG. 9A** shows an EGG waveform of an animal and an EGG waveform of the animal after pre-processing by independent component analysis (ICA). **FIG. 9B** illustrates EGG waveforms taken from unknown sources by sensors on the biological signal detection unit **200**, which include noise,

and EGG waveforms from which noise has been removed by an independent component analyser (ICA) **900**.

[**0080**] To measure how hungry an animal is, an EGG is taken from which parameters indicative of the electrical activity of gastric myoblasts can be extracted. To this end, the wearable sensor module as shown in **FIG. 3B** is used. The electrodes are arranged in the sensor module such as to contact appropriate positions of the animal's abdomen so as to detect electrical signals.

[**0081**] According to the present invention, since the animal is forced to wear the sensor module serving as the biological signal detection unit **200** so that the electrical signals can be continuously detected, a large motion artifact due to the motion of the animal can result. To eliminate this problem, it is preferable to further perform a pre-process of blind source separation in the ICA so as to separate a motion waveform, an instrumental noise waveform, and a target EGG signal, after measuring an EGG using a multi-channel electrode array in the sensor module corresponding to the biological signal detection unit **200**. A detailed description on ICA can be found in "Independent Component Analysis", Aapo Hyvarinen, Wiley, 2001).

[**0082**] **FIG. 10A** shows EGG waveforms after pre-processing, and **FIG. 10B** shows a time-varying spectrum obtained using the EGG waveforms of **FIG. 10A**. The EGG waveforms after post-processing as shown in **FIG. 9** are cut to, for example, a length of about 50 seconds, as shown in **FIG. 10A**, and overlapped by 10 seconds in order to obtain the time-varying spectrum of **FIG. 10B**.

[**0083**] It is preferable that the time-varying spectrum be obtained using a Burg algorithm-based autoregressive model.

[**0084**] *J. Chen et al.* reported EGG spectrum variations with respect to the amount of time passed after eating in *IEEE Transactions on Biomedical Engineering*, 1993, under the title of "Spectral Analysis of Episodic Rhythmic Variations in the Cutaneous Electrogastrogram". Based on this report, the gastric condition of the animal can be measured using the EGG spectrum.

[**0085**] The feature vector extraction unit **230** measures EGG spectra several times before and after eating using a particular pet, classifies the level of hunger into one of many levels, and generates 2-dimensional feature vector data which is constituted of spectral peaks and widths. The values of the spectral peaks and widths can be obtained using the time-varying spectra of **FIG. 10B**. The feature vector extraction unit **230**.

[**0086**] The biological condition analysis unit **250** compares the feature vector related to the level of hunger with the reference vector stored in the biological information database **240** and determines the current gastric condition of the animal corresponding to the level of hunger.

[**0087**] **FIG. 11** shows an example of an EMG waveform related to a bowel movement. In order to determine whether the animal needs to have a bowel movement, an EMG of the anal muscles is measured by contacting an electrode/sensor of the sensor module to the anal muscles, and the amplitude of the EMG signal is compared with reference data for the normal condition. As a result, it can be determined whether the animal needs to have a bowel movement from the

contraction of the anal muscles. The bowels are emptied after a predetermined ordinary period following the contraction period. The condition of the bowels can be measured from an EMG taken of the excretive organic muscles.

[**0088**] In the ordinary period, a basal electrical activity is detected. As the sphincter ani are contracted to control the bowl movement need, the electrical activity increases. When the sphincter ani are strained to allow bowel movement, the sphincter ani are relaxed, and the electrical activity decreases.

[**0089**] The magnitude of EMG signals can be easily measured by those of ordinary skill in the art, using an envelope detection method including zero-clipping and smoothing processes.

[**0090**] The levels of tension and fear can be determined from the heart rate variability, EDA, and skin temperature. One of ordinary skill in the art can easily determine the levels of tension and fear using the method according to the present invention.

[**0091**] After the determination of the biological condition of the animal by the biological condition analysis unit **250** is completed, it is preferable that the animal's owner be informed of the result of the determination through the wireless transmission unit **260**.

[**0092**] Alternatively, the biological signals of the animal detected in step **100** or the biological condition of the animal determined in step **120** can be transmitted to an expert, such as a veterinarian, via the wireless transmission unit **260** for special examination. In this case, the result of the special examination can be fed back to the owner through wireless transmission.

[**0093**] Accordingly, the owner can communicate with his/her pet by being informed of the biological condition of the pet.

[**0094**] **FIG. 12** illustrates a system for measuring the biological condition of an animal, which is constructed of a collar type sensor module **1200** or a wearable sensor module **1210**, which contacts the animal's body, a host computer which determines the biological condition of the animal by receiving and processing biological signals, and a wireless personal terminal which receives the result of the animal's determined biological condition.

[**0095**] The collar type sensor module **1200** put around the neck of a pet, which serves as the biological signal detection unit **200**, may include a sensor for measuring PPG from the caroticum, a small semiconductor thermal sensor for sensing the skin temperature, and two metal electrodes for measuring EDA. The sensor for measuring the PPG can be constructed with a photodiode or a light emitting diode (LED). The collar type sensor module **1200** includes a basic signal processing circuit for amplification and filtering and a circuit for wireless transmission.

[**0096**] The PPG, the skin temperature, and the EDA measured and transmitted by the collar type sensor module **1200** are transmitted to a computer via a wireless receiver and a home network. The biological signals transmitted via the wireless receiver can be transmitted to the computer via an interface, for example, RS-232C.

[**0097**] In the computer which receives the biological signals, the feature vector extraction unit **230**, the biological

information database **240**, the biological condition analysis unit **250**, etc. are implemented using software. From these elements, it can be determined whether the response of the animal's autonomic nervous system is joy, sorrow, impatience, or anger. The determined information is transmitted from the computer to a terminal that is carried by the owner, such as a personal data assistant (PDA) or watch-like terminal, and displayed as an icon or text. Alternatively, when the biological condition of the animal is determined to be poor, the result of the determination and the detected biological signals can be immediately transmitted to a previously assigned expert, such as a veterinarian, for diagnostic purposes.

[**0098**] When the wearable sensor module **1210** is used as the biological signal detection unit **200** so as to measure the condition of the animal, an ECG, EGG, and anal EMG can be additionally measured. As a result, in addition to the above-listed emotions, the biological needs of the animals, such as hunger or bowel movement, can be determined.

[**0099**] While the present invention has been particularly shown and described with reference to preferred embodiments thereof, it will be understood by those of ordinary skill in the art that various changes in form and details may be made to the present invention without departing from the spirit and scope of the present invention as defined by the appended claims. The above-described embodiments are provided for illustrative purposes so that the present invention will be thorough and complete and are not intended to limit the spirit and scope of the present invention.

[**0100**] It will be appreciated by one of ordinary skill in the art that each of the steps in the animal's condition determination method according to the present invention can be variously embedded using software by general programming or using hardware.

[**0101**] Some steps of the method according to the present invention may be embodied as computer-readable program code units embedded in a computer-usable medium, including but not limited to storage media such as magnetic storage media (e.g., ROM's, floppy disks, hard disks, etc.), optically-readable media (e.g., CD-ROMs, DVDs, etc.), and carrier waves (e.g., transmission over the Internet). The computer-readable medium has embodied thereon computer-readable program codes that can be run on a number of computer systems connected via a network.

[**0102**] According to the present invention, biological signals of an animal are obtained from the skin temperature, ECG, PPG, EDA, EMG, and EGG measured using a biological signal detection unit attached to the animal skin, and feature vectors, including the mean heart rate in the PPG and its standard deviation, the VLF, LF, and HF components of heart rate variability, the frequency and mean amplitude of skin conductance responses in the EDA, and the mean and maximum skin temperatures, can be extracted from the biological signals. The feature vectors are compared with reference vectors stored in a predetermined database, which reflect the behaviors, needs, and emotions of different animals for various biological conditions, to determine the biological condition of the animal, for example, whether the animal feels hunger or fear, how much the animal is stressed, or whether the animal needs to have a bowel movement. As a result, although human languages are not used, an animal's owner or handler can determine the animal's biological

condition through communication with his/her animal, thereby providing an efficient pet breeding method.

[**0103**] When a biological signal-based system is applied to people for non-medical purposes, one inconvenience that is apparent is that sensors must always be attached to the object. However, this inconvenience does not seem serious for the pets.

[**0104**] According to the present invention, an animal's owner can reliably measure the emotional condition or some biological needs of his/her pets through instrumental communication, not through human languages. In addition, the animal's owner can monitor the condition of his/her pet outdoors using a home network, a wireless phone, or a PDA, which have become increasingly popular.

What is claimed is:

1. A method for determining the biological condition of an animal by acquiring and analyzing a biological signal, the method comprising:

- (a) acquiring a predetermined biological signal using a biological signal detection unit which is attached to the animal;
- (b) extracting a predetermined feature vector from the acquired predetermined biological signal; and
- (c) analyzing and determining the biological condition of the animal, including emotions and needs of the animal, from the predetermined feature vector.

2. A method for determining the biological condition of an animal by acquiring and analyzing biological signals, the method comprising:

- (a) acquiring biological signals from skin temperature, a photoplethysmogram (PPG), an electrocardiogram (ECG), electrodermal activity (EDA), an electromyogram (EMG), and an electrogastragram (EGG) using a biological signal detection unit which is attached to the animal's skin;
- (b) extracting feature vectors from the acquired biological signals, the feature vectors including the mean heart rate of the photoplethysmogram and its standard deviation, the very low frequency, low frequency, and high frequency components of heart rate variability, the frequency and mean amplitude of skin conductance responses which are obtainable from the electrodermal activity, and the mean and maximum skin temperatures; and
- (c) analyzing and determining the biological condition, including needs and emotions, of the animal as to whether or not the animal feels hunger or fear, how much the animal is stressed, or whether or not the animal needs to have a bowel movement, using a support vector machine which has learned reference vectors, which reflect the behaviors, needs, and emotions of different kinds of animals for various biological conditions and are stored in a predetermined database.

3. The method of claim 2, wherein extracting the mean heart rate as one of the feature vectors in step (b) from the photoplethysmogram, which is acquired as a biological signal in step (a), comprises:

- (b1) low-pass filtering the photoplethysmogram to remove high frequency noise;

- (b2) median-filtering an output signal in step (b1), from which the high frequency noise is removed, to estimate a baseline variation to a very low frequency;
- (b3) subtracting an output signal in step (b2) from the output signal in step (b1) to obtain a waveform from which the baseline variation and direct current and high frequency components are removed; and
- (b4) matching-filtering an output signal in step (b3) to obtain the location of peaks of the photoplethysmogram and measure the heart rate and heart rate variability.

4. The method of claim 2, wherein extracting the very low frequency, low frequency, and high frequency components of heart rate variability as feature vectors in step (b) from the electrocardiogram, which is acquired as a biological signal in step (a), comprises:

- (b1') bandpass-filtering the electrocardiogram to remove background noise which does not belong to the electrocardiographic frequency band;
- (b2') median-filtering an output signal in step (b1') from which the background noise is removed to estimate a baseline variation;
- (b3') subtracting an output signal in step (b1') from the output signal in step (b2') to obtain a waveform from which the baseline variation and noise which does not belong to the frequency band are removed;
- (b4') applying an output signal in step (b3') to a Teager energy operator to detect R-peaks in which the amplitude and frequency abruptly rise;
- (b5') measuring time-series heart rate variability from the intervals of the R-peaks; and
- (b6') calculating the power of particular frequency bands from the measured time-series heart rate variability through autoregressive modelling using the Burg algorithm.

5. The method of claim 4, wherein when the standard deviation of heart rates is calculated as one of the feature vectors in step (b), the heart rates within a predetermined range of the maximum and minimum heart rates are excluded.

6. The method of claim 2, wherein extracting the frequency and amplitude of skin conductance responses as feature vectors in step (b) from the electrodermal activity, which is acquired as a biological signal in step (a), comprises:

- (b1'') down-sampling an input electrodermal activity waveform;
- (b2'') obtaining a differential waveform from an output waveform in step (b1'');
- (b3'') smoothening the differential waveform in step (b2'') by convolution with a Bartlett window having a predetermined length; and
- (b4'') determining two points of the smoothened waveform that have a predetermined threshold level as the start and end points of a skin conductance response, respectively.

7. The method of claim 2, wherein in step (c), whether or not the animal feels hunger is determined using a feature vector extracted from the electrogastrogram acquired as a biological signal in step (a).

8. The method of claim 7, wherein in step (b), blind source separation is performed on the electrogastrogram acquired in step (a) by independent component analysis in order to remove noise from an animal's motion and an instrumental noise waveform, and the resulting electrogastrogram is cut to a time length and overlapped by a predetermined time period to obtain a time-varying spectrum through autoregressive modelling using the Burg algorithm as a feature vector indicating the degree of hunger of the animal, and

in step (c), based on a plurality of electrogastrograms measured in step (b), the degree of hunger is classified into a predetermined number of levels, 2-dimensional feature vector data which are constituted of spectral peaks and widths for each level are generated, and the degree of hunger of the animal is determined by comparing the 2-dimensional feature vector with the reference vector stored in a predetermined support vector machine.

9. The method of claim 2, wherein in step (c), whether or not the animal feels fear and how much the animal is stressed are determined using the feature vectors extracted from the electrocardiogram, electrodermal activity, and skin temperature acquired in step (a).

10. The method of claim 2, wherein in step (c), whether or not the animal needs to have a bowel movement is determined using a feature vector extracted from the electromyogram acquired in step (a) of anal muscles.

11. The method of claim 2, further comprising (d) informing an animal's owner of the biological condition, including needs and emotions, of the animal via a predetermined communication unit.

12. The method of claim 2, further comprising:

(e) transmitting the biological signals of the animal acquired in step (a) and/or the biological condition, including needs and emotions, of the animal determined in step (c) to an animal's handler via a predetermined communication unit; and

(f) the animal's handler informing an animal's owner of the result of a diagnosis performed using the biological signals and/or the biological condition of the animal via a predetermined communication unit.

13. An apparatus for measuring the biological condition of an animal by acquiring and analysing biological signals, the apparatus comprising:

a biological signal detection unit which is attached to the animal's skin and detects a biological signal of the animal; and

a condition analysis unit which determines the biological condition, including needs and emotions, of the animal using a predetermined feature vector extracted by analyzing the biological signal detected by the biological signal detection unit.

14. The apparatus of claim 13, further comprising a transmission unit which wirelessly transmits the biological condition, including needs and emotions, of the animal that has been analyzed by the condition analysis unit to an animal's owner.

15. The apparatus of claim 13, further comprising a transmission unit which wireless transmits the biological signal(s) detected by the biological signal detection unit or the biological condition determined by the condition analysis unit to a predetermined expert, including a veterinarian.

16. An apparatus for measuring the biological condition of an animal by acquiring and analysing biological signals, the apparatus comprising:

a biological signal detection unit including a plurality of sensors and electrodes, which is attached to the animal's skin and detects biological signals from skin temperature, an electrocardiogram (ECG), a photoplethysmogram (PPG), electrodermal activity (EDA), an electromyogram (EMG), and an electrogastrogram (EGG);

a feature vector extraction unit which extracts feature vectors from the biological signals detected by the biological signal detection unit, the feature vectors including the mean heart rate of the photoplethysmogram and its standard deviation, the very low frequency, low frequency, and high frequency components of heart rate variability, the frequency and mean amplitude of skin conductance responses, and the mean and maximum skin temperatures;

a biological information database which stores reference vectors reflecting the behaviors, needs, and emotions of different kinds of animals for various biological conditions; and

a biological condition analysis unit which compares the feature vectors extracted by the feature vector extraction unit with reference vectors of the biological information database and determines the biological condition, including needs and emotions, of the animal as to whether or not the animal feels hunger or fear, how much the animal is stressed, or whether or not the animal needs to have a bowel movement.

17. The apparatus of claim 16, further comprising a transmission unit which wirelessly transmits the biological condition, including needs and emotions, of the animal that has been analyzed by the biological condition analysis unit to an animal's owner.

18. The apparatus of claim 16, further comprising a transmission unit which wireless transmits the biological signal(s) detected by the biological signal detection unit or the biological condition determined by the biological condition analysis unit to a predetermined expert, including a veterinarian.

* * * * *

专利名称(译)	通过获取和分析其生物信号来测量动物状况的方法和装置		
公开(公告)号	US20030166996A1	公开(公告)日	2003-09-04
申请号	US10/339461	申请日	2003-01-10
[标]申请(专利权)人(译)	三星电子株式会社		
申请(专利权)人(译)	SAMSUNG ELECTRONICS CO., LTD.		
当前申请(专利权)人(译)	SAMSUNG ELECTRONICS CO., LTD.		
[标]发明人	KIM KYUNG HWAN BANG SEOK WON LEE HYOUNG KI		
发明人	KIM, KYUNG-HWAN BANG, SEOK-WON LEE, HYOUNG-KI		
IPC分类号	A01K67/00 A01K29/00 A61B5/01 A61B5/024 A61B5/0245 A61B5/026 A61B5/04 A61B5/0402 A61B5/0452 A61B5/0456 A61B5/0488 A61B5/05 A61B5/16 A61D13/00 A61B5/00		
CPC分类号	A01K29/00 A61B5/024 A61B5/04 Y10S128/92 A61B5/0488 A61B5/16 A61B5/7264 A61B5/0456 A61B5/165		
优先权	1020020001696 2002-01-11 KR		
其他公开文献	US7282028		
外部链接	Espacenet USPTO		

摘要(译)

提供了一种通过获取和分析其生物信号来测量动物的生物状况的方法和装置。来自皮肤温度，光电脉搏波图（PPG），心电图（ECG），皮肤电活动（EDA），肌电图（EMG）和胃电图（EGG）的生物信号使用附着于生物信号检测单元的生物信号检测单元进行检测。动物的皮肤。特征向量，包括光动态描记图的平均心率及其标准偏差，心率变异性的极低频率，低频率和高频率分量，皮肤电导响应的频率和平均幅度，以及平均和最大皮肤温度从检测到的生物信号中提取。动物关于动物是否感到饥饿或恐惧，动物受到多大压力，动物是否需要排便的生物状况（包括需求和情绪）是使用模式分类器确定的。它已经学习了参考向量，它反映了不同种类动物对各种生物条件的行为，需求和情绪，并存储在预定的数据库中。因此，动物的生物学状况可以通过仪器交流而不是通过人类语言来确定，并且可以有效地管理宠物的繁殖。

