

(19)



(11)

EP 2 967 224 B1

(12)

EUROPEAN PATENT SPECIFICATION

(45) Date of publication and mention of the grant of the patent:
17.01.2018 Bulletin 2018/03

(51) Int Cl.:
A47C 27/08 ^(2006.01) **A47C 31/12** ^(2006.01)
A61B 5/11 ^(2006.01) **A61B 5/00** ^(2006.01)

(21) Application number: **14716711.8**

(86) International application number:
PCT/US2014/026526

(22) Date of filing: **13.03.2014**

(87) International publication number:
WO 2014/143634 (18.09.2014 Gazette 2014/38)

(54) INFLATABLE AIR MATTRESS SYSTEM WITH DETECTION TECHNIQUES

AUFBLASBARES LUFTMATRATZENSYSYSTEM MIT ERKENNUNGSVERFAHREN

SYSTÈME DE MATELAS PNEUMATIQUE GONFLABLE AYANT DES TECHNIQUES DE DÉTECTION

(84) Designated Contracting States:
AL AT BE BG CH CY CZ DE DK EE ES FI FR GB GR HR HU IE IS IT LI LT LU LV MC MK MT NL NO PL PT RO RS SE SI SK SM TR

- **TILSTRA, Matthew Wayne**
Rogers, MN 55374 (US)
- **YOUNG, Steven**
Campbell, CA 95008 (US)
- **HEWITT, Carl**
Campbell, CA 95008 (US)
- **ZHOVNIROVSKY, Yuri**
Campbell, CA 95008 (US)

(30) Priority: **14.03.2013 US 201361781311 P**

(43) Date of publication of application:
20.01.2016 Bulletin 2016/03

(74) Representative: **Conroy, John**
Fish & Richardson P.C.
Highlight Business Towers
Mies-van-der-Rohe-Straße 8
80807 München (DE)

(73) Proprietors:
• **SELECT COMFORT CORPORATION**
Minneapolis, Minnesota 55442 (US)
• **SleepIQ Labs Inc.**
San Jose CA 95113 (US)

(72) Inventors:
• **NUNN, Rob**
Eden Prairie, MN 55346 (US)
• **PALASHEWSKI, Wade Daniel**
Minneapolis, MN 55442 (US)

(56) References cited:
EP-A1- 2 649 908 **WO-A1-2009/108228**
US-A1- 2003 221 261 **US-A1- 2011 015 495**
US-A1- 2011 144 455

EP 2 967 224 B1

Note: Within nine months of the publication of the mention of the grant of the European patent in the European Patent Bulletin, any person may give notice to the European Patent Office of opposition to that patent, in accordance with the Implementing Regulations. Notice of opposition shall not be deemed to have been filed until the opposition fee has been paid. (Art. 99(1) European Patent Convention).

Description

[0001] This application claims the benefit of priority of U.S. Provisional Application No. 61/781,311 as filed on March 14, 2013.

CROSS-REFERENCES

[0002] The subject matter described in this application is related to subject matter disclosed in the following applications: U.S. Application Serial No. 61/781,266 (Attorney Docket No. 3500.049PRV), filed on March 14, 2013, titled "INFLATABLE AIR MATTRESS ALARM AND MONITORING SYSTEM"; U.S. Application Serial No. 61/781,503 (Attorney Docket No. 3500.050PRV), filed on March 14, 2013, titled "INFLATABLE AIR MATTRESS SYSTEM ARCHITECTURE"; U.S. Application Serial No. 61/781,541 (Attorney Docket No. 3500.051PRV), filed on March 14, 2013, titled "INFLATABLE AIR MATTRESS AUTOFILL AND OFF BED PRESSURE ADJUSTMENT"; U.S. Application Serial No. 61/781,571 (Attorney Docket No. 3500.052PRV), filed on March 14, 2013, titled "INFLATABLE AIR MATTRESS SLEEP ENVIRONMENT ADJUSTMENT AND SUGGESTIONS"; U.S. Application Serial No. 61/782,394 (Attorney Docket No. 3500.053PRV), filed on March 14, 2013, titled "INFLATABLE AIR MATTRESS SNORING DETECTION AND RESPONSE"; U.S. Application Serial No. 61/781,296 (Attorney Docket No. 3500.054PRV), filed on March 14, 2013, titled "INFLATABLE AIR MATTRESS WITH LIGHT AND VOICE CONTROLS."

TECHNICAL FIELD

[0003] This patent document pertains generally to air mattresses and more particularly, but not by way of limitation, to an inflatable air mattress system.

BACKGROUND

[0004] Air bed systems, such as the one described in U.S. Pat. No. 5,904,172, generally allow a user to select a desired pressure for each air chamber within the mattress. Upon selecting the desired pressure, a signal is sent to a pump and valve assembly in order to inflate or deflate the air bladders as necessary in order to achieve approximately the desired pressure within the air bladders.

[0005] In various examples, an air mattress control system allows a user to adjust the firmness or position of an air mattress bed. The mattress may have more than one zone thereby allowing a left and right side of the mattress to be adjusted to different firmness levels. Additionally, the bed may be adjustable to different positions. For example, the head section of the bed may be raised up while the foot section of the bed stays in place. In various examples, two separate remote controls are used to adjust the position and firmness, respectively.

[0006] WO 2009/108228 describes a system for controlling a bedroom environment includes an environmental data collector configured to collect environmental data relating to the bedroom environment; a sleep data collector configured to collect sleep data relating to a person's state of sleep; an analysis unit configured to analyze the collected environmental data and the collected sleep data and to determine an adjustment of the bedroom environment that promotes sleep of the person; and a controller configured to effect the adjustment of the bedroom environment.

[0007] US 20110015495 describes A sleep management method and system for improving the quality of sleep of a user which monitors one or more objective parameters relevant to sleep quality of the user when in bed and receives from the user in waking hours via a portable device such as a mobile phone feedback from objective test data on cognitive and/or psychomotor performance.

[0008] US 20030221261 describes mattress for supporting a reclining body. The mattress includes a resilient top member having a top region possessing uniform displacement parameters and also includes resilient supporting means supporting the top member with variable displacement.

BRIEF DESCRIPTION OF DRAWINGS

[0009] Some embodiments are illustrated by way of example and not limitation in the figures of the accompanying drawings in which:

FIG. 1 is a diagrammatic representation of an air bed system, according to an example.

FIG. 2 is a block diagram of various components of the air bed system of FIG. 1, according to an example.

FIG. 3 is a block diagram of an air bed system architecture, according to an example.

FIG. 4 is a block diagram of machine in the example form of a computer system within which a set instructions, for causing the machine to perform any one or more of the methodologies discussed herein, may be executed.

FIG. 5 is a flow diagram depicting an example method of detecting motion of a user of an air mattress, in accordance with various techniques of this disclosure.

FIG. 6 is a flow diagram depicting an example method of detecting the presence of a user of an air mattress, in accordance with various techniques of this disclosure.

FIG. 7 is a flow diagram depicting an example method of detecting the presence of a user of an air mattress, in accordance with various techniques of this disclosure.

DETAILED DESCRIPTION

[0010] FIG. 1 is a diagrammatic representation of air bed system 10 in an example embodiment. System 10 can include bed 12, which can comprise at least one air chamber 14 surrounded by a resilient border 16 and encapsulated by bed ticking 18. The resilient border 16 can comprise any suitable material, such as foam.

[0011] As illustrated in FIG. 1, bed 12 can be a two chamber design having a first air chamber 14A and a second air chamber 14B. First and second air chambers 14A and 14B can be in fluid communication with pump 20. Pump 20 can be in electrical communication with a remote control 22 via control box 24. Remote control 22 can communicate via wired or wireless means with control box 24. Control box 24 can be configured to operate pump 20 to cause increases and decreases in the fluid pressure of first and second air chambers 14A and 14B based upon commands input by a user through remote control 22. Remote control 22 can include display 26, output selecting means 28, pressure increase button 29, and pressure decrease button 30. Output selecting means 28 can allow the user to switch the pump output between the first and second air chambers 14A and 14B, thus enabling control of multiple air chambers with a single remote control 22. For example, output selecting means may be a physical control (e.g., switch or button) or an input control displayed on display 26. Alternatively, separate remote control units can be provided for each air chamber and may each include the ability to control multiple air chambers. Pressure increase and decrease buttons 29 and 30 can allow a user to increase or decrease the pressure, respectively, in the air chamber selected with the output selecting means 28. Adjusting the pressure within the selected air chamber can cause a corresponding adjustment to the firmness of the air chamber.

[0012] FIG. 2 is a block diagram detailing data communication between certain components of air bed system 10 according to various examples. As shown in FIG. 2, control box 24 can include power supply 34, processor 36, memory 37, switching means 38, and analog to digital (A/D) converter 40. Switching means 38 can be, for example, a relay or a solid state switch. Switching means 38 can be located in the pump 20 rather than the control box 24.

[0013] Pump 20 and remote control 22 can be in two-way communication with the control box 24. Pump 20 can include a motor 42, a pump manifold 43, a relief valve 44, a first control valve 45A, a second control valve 45B, and a pressure transducer 46, and can be fluidly connected with the first air chamber 14A and the second air chamber 14B via a first tube 48A and a second tube 48B, respectively. First and second control valves 45A and 45B can be controlled by switching means 38, and can be operable to regulate the flow of fluid between pump 20 and first and second air chambers 14A and 14B, respectively.

[0014] In an example, pump 20 and control box 24 can be provided and packaged as a single unit. Alternatively, pump 20 and control box 24 can be provided as physically separate units.

[0015] In operation, power supply 34 can receive power, such as 110 VAC power, from an external source and can convert the power to various forms required by certain components of the air bed system 10. Processor 36 can be used to control various logic sequences associated with operation of the air bed system 10, as will be discussed in further detail below.

[0016] The example of the air bed system 10 shown in FIG. 2 contemplates two air chambers 14A and 14B and a single pump 20. However, other examples may include an air bed system having two or more air chambers and one or more pumps incorporated into the air bed system to control the air chambers. In an example, a separate pump can be associated with each air chamber of the air bed system or a pump may be associated with multiple chambers of the air bed system. Separate pumps can allow each air chamber to be inflated or deflated independently and simultaneously. Furthermore, additional pressure transducers can also be incorporated into the air bed system such that, for example, a separate pressure transducer can be associated with each air chamber.

[0017] In the event that the processor 36 sends a decrease pressure command to one of air chambers 14A or 14B, switching means 38 can be used to convert the low voltage command signals sent by processor 36 to higher operating voltages sufficient to operate relief valve 44 of pump 20 and open control valves 45A or 45B. Opening relief valve 44 can allow air to escape from air chamber 14A or 14B through the respective air tube 48A or 48B. During deflation, pressure transducer 46 can send pressure readings to processor 36 via the A/D converter 40. The A/D converter 40 can receive analog information from pressure transducer 46 and can convert the analog information to digital information useable by processor 36. Processor 36 may send the digital signal to remote control 22 to update display 26 on the remote control in order to convey the pressure information to the user.

[0018] In the event that processor 36 sends an increase pressure command, pump motor 42 can be energized, sending air to the designated air chamber through air tube 48A or 48B via electronically operating corresponding valve 45A or 45B. While air is being delivered to the designated air chamber in order to increase the firmness of the chamber, pressure transducer 46 can sense pressure within pump manifold 43. Again, pressure transducer 46 can send pressure readings to processor 36 via A/D converter 40. Processor 36 can use the information received from A/D converter 40 to determine the difference between the actual pressure in air chamber 14A or 14B and the desired pressure. Processor 36 can send the digital signal to remote control 22 to update display 26 on the remote control in order to convey the pressure information to the user.

[0019] Generally speaking, during an inflation or deflation process, the pressure sensed within pump manifold 43 provides an approximation of the pressure within the air chamber. An example method of obtaining a pump manifold pressure reading that is substantially equivalent to the actual pressure within an air chamber is to turn off pump 20, allow the pressure within the air chamber 14A or 14B and pump manifold 43 to equalize, and then sense the pressure within pump manifold 43 with pressure transducer 46. Thus, providing a sufficient amount of time to allow the pressures within pump manifold 43 and chamber 14A or 14B to equalize may result in pressure readings that are accurate approximations of the actual pressure within air chamber 14A or 14B. In various examples, the pressure of 48A/B is continuously monitored using multiple pressure sensors.

[0020] In an example, another method of obtaining a pump manifold pressure reading that is substantially equivalent to the actual pressure within an air chamber is through the use of a pressure adjustment algorithm. In general, the method can function by approximating the air chamber pressure based upon a mathematical relationship between the air chamber pressure and the pressure measured within pump manifold 43 (during both an inflation cycle and a deflation cycle), thereby eliminating the need to turn off pump 20 in order to obtain a substantially accurate approximation of the air chamber pressure. As a result, a desired pressure setpoint within air chamber 14A or 14B can be achieved without the need for turning pump 20 off to allow the pressures to equalize. The latter method of approximating an air chamber pressure using mathematical relationships between the air chamber pressure and the pump manifold pressure is described in detail in U.S. Application Serial No. 12/936,084.

[0021] FIG. 3 illustrates an example air bed system architecture 300. Architecture 300 includes bed 301, central controller 302, firmness controller 304, articulation controller 306, temperature controller 308 in communication with one or more temperature sensors 309, external network device 310, remote controllers 312, 314, and voice controller 316. While described as using an air bed, the system architecture may also be used with other types of beds.

[0022] As illustrated in FIG. 3, network bed architecture 300 is configured as a star topology with central controller 302 and firmness controller 304 functioning as the hub and articulation controller 306, temperature controller 308, external network device 310, remote controls 312, 314, and voice controller 316 functioning as possible spokes, also referred to herein as components. Thus, in various examples, central controller 302 acts a relay between the various components.

[0023] In yet another example, central controller 302 listens to communications (e.g., control signals) between components even if the communication is not being relayed through central controller 302. For example, consider a user sending a command using remote 312 to

temperature controller 308. Central controller 302 may listen for the command and check to determine if instructions are stored at central controller 302 to override the command (e.g., it conflicts with a previous setting). Central controller 302 may also log the command for future use (e.g., determining a pattern of user preferences for the components).

[0024] In other examples, different topologies may be used. For example, the components and central controller 302 may be configured as a mesh network in which each component may communicate with one or all of the other components directly, bypassing central controller 302. In various examples, a combination of topologies may be used. For example, remote controller 312 may communicate directly to temperature controller 308 but also relay the communication to central controller 302.

[0025] In various examples, the controllers and devices illustrated in FIG. 3 may each include a processor, a storage device, and a network interface. The processor may be a general purpose central processing unit (CPU) or application-specific integrated circuit (ASIC). The storage device may include volatile or non-volatile static storage (e.g., Flash memory, RAM, EPROM, etc.). The storage device may store instructions which, when executed by the processor, configure the processor to perform the functionality described herein. For example, a processor of firmness control 304 may be configured to send a command to a relief valve to decrease the pressure in a bed.

[0026] In various examples, the network interface of the components may be configured to transmit and receive communications in a variety of wired and wireless protocols. For example, the network interface may be configured to use the 802.11 standards (e.g., 802.11a/b/c/g/n/ac), PAN network standards such as 802.15.4 or Bluetooth, infrared, cellular standards (e.g., 3G/4G etc.), Ethernet, and USB for receiving and transmitting data. The previous list is not intended to be exhaustive and other protocols may be used. Not all components of FIG. 3 need to be configured to use the same protocols. For example, remote control 312 may communicate with central controller 302 via Bluetooth while temperature controller 308 and articulation controller 306 are connected to central controller using 802.15.4. Within FIG. 3, the lightning connectors represent wireless connections and the solid lines represent wired connections, however, the connections between the components is not limited to such connections and each connection may be wired or wireless.

[0027] Moreover, in various examples, the processor, storage device, and network interface of a component may be located in different locations than various elements used to affect a command. For example, as in FIG. 1, firmness controller 302 may have a pump that is housed in a separate enclosure than the processor used to control the pump. Similar separation of elements may be employed for the other controllers and devices in FIG. 3.

[0028] In various examples, firmness controller 304 is

configured to regulate pressure in an air mattress. For example, firmness controller 304 may include a pump such as described with reference to FIG. 2 (see e.g., pump 20). Thus, in an example, firmness controller 304 may respond to commands to increase or decrease pressure in the air mattress. The commands may be received from another component or based on stored application instructions that are part of firmness controller 304.

[0029] As illustrated in FIG. 3 central controller 302 includes firmness controller 304 and pump 305. Thus, in an example, the processor of central controller 302 and firmness control 304 may be the same processor. Furthermore, the pump may also be part of central controller 302. Accordingly, central controller 302 may be responsible for pressure regulation as well as other functionality as described in further portions of this disclosure.

[0030] In various examples, articulation controller 306 is configured to adjust the position of a bed (e.g., bed 301) by adjusting the foundation that supports the bed. In an example, separate positions may be set for two different beds (e.g., two twin beds placed next to each other). The foundation may include more than one zone that may be independently adjusted. Articulation control 306 may also be configured to provide different levels of massage to a person on the bed.

[0031] In various examples, temperature controller 308 is configured to increase, decrease, or maintain the temperature of a user. For example, a pad may be placed on top of or be part of the air mattress. Air may be pushed through the pad and vented to cool off a user of the bed. Conversely, the pad may include a heating element that may be used to keep the user warm. In various examples, the pad includes the temperature sensor 309 and temperature controller 308 receives temperature readings from the temperature sensor 309. In other examples, the temperature sensor 309 can be separate from the pad, e.g., part of the air mattress or foundation.

[0032] In various examples, additional controllers may communicate with central controller 302. These controllers may include, but are not limited to, illumination controllers for turning on and off light elements placed on and around the bed and outlet controllers for controlling power to one or more power outlets.

[0033] In various examples, external network device 310, remote controllers 312, 314 and voice controller 316 may be used to input commands (e.g., from a user or remote system) to control one or more components of architecture 300. The commands may be transmitted from one of the controllers 312, 314, or 316 and received in central controller 302. Central controller 302 may process the command to determine the appropriate component to route the received command. For example, each command sent via one of controllers 312, 314, or 316 may include a header or other metadata that indicates which component the command is for. Central controller 302 may then transmit the command via central controller 302's network interface to the appropriate component. In some examples, the commands may be transmitted

to one or more cloud-based servers for processing.

[0034] For example, a user may input a desired temperature for the user's bed into remote control 312. The desired temperature may be encapsulated in a command data structure that includes the temperature as well as identifies temperature controller 308 as the desired component to be controlled. The command data structure may then be transmitted via Bluetooth to central controller 302. In various examples, the command data structure is encrypted before being transmitted. Central controller 302 may parse the command data structure and relay the command to temperature controller 308 using a PAN. Temperature controller 308 may be then configured its elements to increase or decrease the temperature of the pad depending on the temperature originally input into remote control 312.

[0035] In various examples, data may be transmitted from a component back to one or more of the remote controls. For example, the current temperature as determined by a sensor element of temperature controller 308, e.g., temperature sensor 309, the pressure of the bed, the current position of the foundation or other information may be transmitted to central controller 302. Central controller 302 may then transmit the received information and transmit it to remote control 312 where it may be displayed to the user.

[0036] In various examples, multiple types of devices may be used to input commands to control the components of architecture 300. For example, remote control 312 may be a mobile device such as a smart phone or tablet computer running an application. Other examples of remote control 312 may include a dedicated device for interacting with the components described herein. In various examples, remote controls 312/314 include a display device for displaying an interface to a user. Remote control 312/314 may also include one or more input devices. Input devices may include, but are not limited to, keypads, touchscreen, gesture, motion and voice controls.

[0037] Remote control 314 may be a single component remote configured to interact with one component of the mattress architecture. For example, remote control 314 may be configured to accept inputs to increase or decrease the air mattress pressure. Voice controller 316 may be configured to accept voice commands to control one or more components. In various examples, more than one of the remote controls 312/314 and voice controller 316 may be used.

[0038] With respect to remote control 312, the application may be configured to pair with one or more central controllers. For each central controller, data may be transmitted to the mobile device that includes a list of components linked with the central controller. For example, consider that remote control 312 is a mobile phone and that the application has been authenticated and paired with central controller 302. Remote control 312 may transmit a discovery request to central controller 302 to inquiry about other components and available services, e.g., services or components available in the cloud.

In response, central controller 302 may transmit a list of services that includes available functions for adjusting the firmness of the bed, position of the bed, and temperature of the bed. In various embodiments, the application may then display functions for increasing/decreasing pressure of the air mattress, adjusting positions of the bed, and adjusting temperature. If components are added/removed to the architecture under control of central controller 302, an updated list may be transmitted to remote control 312 and the interface of the application may be adjusted accordingly.

[0039] In various examples, central controller 302 is configured as a distributor of software updates to components in architecture 300. For example, a firmware update for temperature controller 308 may become available. The update may be loaded into a storage device of central controller 302 (e.g., via a USB interface, a smartphone over Bluetooth, and from the cloud over WiFi). In wireless applications, the central controller 302 may, for example, receive updates from the cloud either from wifi or from a mobile connection over Bluetooth. Central controller 302 may then transmit the update to temperature controller 308 with instructions to update. Temperature controller 308 may attempt to install the update. A status message may be transmitted from temperature controller 308 to central controller 302 indicating the success or failure of the update.

[0040] In various examples, central controller 302 is configured to analyze data collected by a pressure transducer (e.g., transducer 46 with respect to FIG. 2) to determine various states of a person lying on the bed. For example, central controller 302 may determine the heart rate or respiration rate of a person lying in the bed. Additional processing may be done using the collected data to determine a possible sleep state of the person. For example, central controller 302 may determine when a person falls asleep and, while asleep, the various sleep states of the person.

[0041] In various examples, external network device 310 includes a network interface to interact with an external server for processing and storage of data related to components in architecture 300. For example, the determined sleep data as described above may be transmitted via a network (e.g., the Internet) from central controller 302 to external network device 310 for storage. In an example, the pressure transducer data may be transmitted to the external server for additional analysis. The external network device 310 may also analyze and filter the data before transmitting it to the external server.

[0042] In an example, diagnostic data of the components may also be routed to external network device 310 for storage and diagnosis on the external server. For example, if temperature controller 308 detects an abnormal temperature reading (e.g., a drop in temperature over one minute that exceeds a set threshold) diagnostic data (sensor readings, current settings, etc.) may be wireless transmitted from temperature controller 308 to central controller 302. Central controller 302 may then transmit

this data via USB to external network device 310. External device 310 may wirelessly transmit the information to a WLAN access point where it is routed to the external server for analysis. In some examples, the external device 310 can transmit a message to a customer service division to initiate a repair call if necessary.

EXAMPLE MACHINE ARCHITECTURE AND MACHINE-READABLE MEDIUM

[0043] FIG. 4 is a block diagram of machine in the example form of a computer system 400 within which instructions, for causing the machine to perform any one or more of the methodologies discussed herein, may be executed. In alternative embodiments, the machine operates as a standalone device or may be connected (e.g., networked) to other machines. In a networked deployment, the machine may operate in the capacity of a server or a client machine in server-client network environment, or as a peer machine in a peer-to-peer (or distributed) network environment. The machine may be a personal computer (PC), a tablet PC, a set-top box (STB), a Personal Digital Assistant (PDA), a cellular telephone, a web appliance, a network router, switch or bridge, or any machine capable of executing instructions (sequential or otherwise) that specify actions to be taken by that machine. Further, while only a single machine is illustrated, the term "machine" shall also be taken to include any collection of machines that individually or jointly execute a set (or multiple sets) of instructions to perform any one or more of the methodologies discussed herein.

[0044] The example computer system 400 includes a processor 402 (e.g., a central processing unit (CPU), a graphics processing unit (GPU), ASIC or a combination), a main memory 404 and a static memory 406, which communicate with each other via a bus 408. The computer system 400 may further include a video display unit 410 (e.g., a liquid crystal display (LCD) or a cathode ray tube (CRT)). The computer system 400 also includes an alphanumeric input device 412 (e.g., a keyboard and/or touchscreen), a user interface (UI) navigation device 414 (e.g., a mouse), a disk drive unit 416, a signal generation device 418 (e.g., a speaker) and a network interface device 420.

MACHINE-READABLE MEDIUM

[0045] The disk drive unit 416 includes a machine-readable medium 422 on which is stored one or more sets of instructions and data structures (e.g., software) 424 embodying or utilized by any one or more of the methodologies or functions described herein. The instructions 424 may also reside, completely or at least partially, within the main memory 404 and/or within the processor 402 during execution thereof by the computer system 400, the main memory 404 and the processor 402 also constituting machine-readable media.

[0046] While the machine-readable medium 422 is

shown in an example embodiment to be a single medium, the term "machine-readable medium" may include a single medium or multiple media (e.g., a centralized or distributed database, and/or associated caches and servers) that store the one or more instructions or data structures. The term "machine-readable medium" shall also be taken to include any tangible medium that is capable of storing, encoding or carrying instructions for execution by the machine and that cause the machine to perform any one or more of the methodologies of the present invention, or that is capable of storing, encoding or carrying data structures utilized by or associated with such instructions. The term "machine-readable medium" shall accordingly be taken to include, but not be limited to, solid-state memories, and optical and magnetic media. Specific examples of machine-readable media include non-volatile memory, including by way of example semiconductor memory devices, e.g., Erasable Programmable Read-Only Memory (EPROM), Electrically Erasable Programmable Read-Only Memory (EEPROM), and flash memory devices; magnetic disks such as internal hard disks and removable disks; magneto-optical disks; and CD-ROM and DVD-ROM disks.

TRANSMISSION MEDIUM

[0047] The instructions 424 may further be transmitted or received over a communications network 426 using a transmission medium. The instructions 424 may be transmitted using the network interface device 420 and any one of a number of well-known transfer protocols (e.g., HTTP). Examples of communication networks include a local area network ("LAN"), a wide area network ("WAN"), the Internet, mobile telephone networks, Plain Old Telephone (POTS) networks, and wireless data networks (e.g., WiFi and WiMax networks). The term "transmission medium" shall be taken to include any intangible medium that is capable of storing, encoding or carrying instructions for execution by the machine, and includes digital or analog communications signals or other intangible media to facilitate communication of such software.

DETECTION TECHNIQUES

[0048] In addition to the techniques described above, this disclosure is directed to techniques for detection of various aspects of a user of system architecture 300. As described in more detail below, user sleeping motion, user presence, and/or user sleeping position can be detected using various techniques described in this disclosure

[0049] Regarding sleeping motion detection, the system architecture 300 can detect the motion of a user while the user is sleeping ("sleeping motion") and determine from the detected motion the restlessness of the user. Using the determined restlessness, the system architecture 300 and, in particular, the central controller 302 can determine a sleep quality metric, index, number, or the

like. In one example, the user can query the system architecture 300 to retrieve a previously determined sleep quality metric. In another example, the system architecture 300 can determine the sleep quality metric when queried by the user. In yet another example, the system architecture 300 can automatically, e.g., without user intervention, determine and report a sleep quality metric to the user, e.g., via a display.

[0050] In accordance with this disclosure, the central controller 302 can detect user sleeping motion via pressure changes. For example, the pressure transducer 46 (of FIG. 2) can be used to monitor the air pressure in the air mattress of the bed 301. If the user on the air mattress is not moving, the air pressure in the mattress can be substantially constant and, as such, the pressure transducer 46 and the central controller 302 will measure no significant pressure changes. When the user on the air mattress is moving, however, the air pressure in the mattress can fluctuate and, as such, the pressure transducer 46 and the central controller 302 can measure pressure changes. Thus, pressure changes measured by the pressure transducer 46 and the central controller 302 can indicate motion of the user on the air mattress.

[0051] In one example implementation, the central controller 302 can execute instructions that cause the pressure transducer 46 to measure air pressure values at a sample rate. In one example, the central controller 302 can store the sampled air pressure values in a memory device. Using a moving (or rolling) average (or other central tendency), for example, the central controller 302 can determine average (or other central tendency) air pressure values and then determine whether the user has moved on the air mattress based on the rolling average. When the user is stationary, the rolling average will be substantially constant, e.g., no pressure changes. When the user moves, e.g., rolls to the side, the air pressure values may fluctuate, thereby changing the value of the rolling average. The central controller 302 can calculate a difference between the rolling average values and determine that the user is moving based on the calculated difference. In some examples, the central controller 302 can initiate a timer using the rolling average values in order to determine how long the user was moving. For example, the central controller 302 can initiate a timer when the rolling average value exceeded a specified value and stop the timer when the rolling average value drops below the specified value. The accumulated time of the timer indicates how long the user was restless during their sleep.

[0052] As indicated above, the central controller 302 can determine a user's sleep state, e.g., rapid eye movement ("REM") or non-rapid eye movement ("NREM"). The central controller 302 can determine a user's sleep state by using various biometric signals such as heart rate, respiration, and/or movement of the user. Techniques for monitoring a user's sleep using heart rate information, respiration rate information, and other user information are disclosed in U.S. Patent Application Pub-

lication No. 20100170043 to Steven J. Young et al., titled "APPARATUS FOR MONITORING VITAL SIGNS". Using the techniques described above, the central controller 302 can detect user motion and correlate the detected motion with a determined sleep state.

[0053] FIG. 5 is a flow diagram depicting an example method of detecting motion of a user of an air mattress. In FIG. 5, the central controller 302 executes instructions that cause the pressure transducer 46 to measure air pressure values at a sample rate (500). The central controller 302 determines rolling average values, for example, based on the measured air pressure values (502). The central controller 302 calculates a difference value between the rolling average values and determines a pressure change based on calculated differences (504). The central controller 302 compares the determined pressure change to a threshold value, e.g., stored in a memory device, and determines that the user is moving if the determined pressure change is above the threshold value (506). In this manner, the central controller can detect sleeping motion of a user.

[0054] In some implementations, the example method shown in FIG. 5 further includes the optional act of the central controller 302 determining a sleep state, e.g., REM or NREM, of the user.

[0055] In addition to the techniques described above, this disclosure is directed to techniques for detecting whether a user is present on the bed 301. In one example implementation, the central controller 302 can detect user presence via gross pressure changes. For example, the central controller 302 and the pressure transducer 46 (of FIG. 2) can be used to monitor the air pressure in the air mattress of the bed 301. If the user sits or lies down on the air mattress, the air pressure in the air mattress changes, e.g., increases, due to the additional weight of the user, which results in a gross pressure change. The central controller 302 determines whether the user is now on the bed based on the gross pressure change, e.g., over some time period. According to the invention, by determining a rate of change of pressure, e.g., over 1-10 minutes, and comparing the determined rate of change to a threshold value, the central controller can determine whether the user is now on the bed.

[0056] Similarly, if the user is on the bed and then gets out of bed, the air pressure in the air mattress changes, e.g., decreases, which results in a gross pressure change. The central controller 302 determine whether the user left the bed based on the gross pressure change, e.g., over some time period. According to the invention, by determining a rate of change of pressure, e.g., over 1-10 minutes, and comparing the determined rate of change to a threshold value, the central controller 302 can determine whether the user left the bed.

[0057] In some example implementations, the techniques for detecting whether a user is present on the bed 301 can be combined with the techniques for detecting user movement described above. For example, in addition to determining a rate of change of pressure and com-

paring the determined rate of change to a threshold value in order to determine whether the user is in or out of the bed 301, the central controller 302 can also use the rolling average techniques described above to detect user movement. For instance, if the central controller 302 determines that a rate of change of pressure is greater than a threshold value, thereby indicating that a user has either gotten into or out of the bed 301, the central controller 302 can further analyze rolling averages of received air pressure values from the pressure transducer 46 (of FIG. 2) to confirm that the user is in the bed 301. If the rolling averages fluctuate, as would be consistent with movement of the user, then the central controller 302 can determine that the user is in the bed 301.

[0058] FIG. 6 is a flow diagram depicting an example method of detecting the presence of a user of an air mattress. In FIG. 6, the central controller 302 executes instructions that cause the pressure transducer 46 to measure air pressure values at a sample rate (600). The central controller 302 determines a rate of gross pressure change, for example, based on the measured air pressure values (602). Then, the central controller 302 compares the determined rate of change to a threshold value (604). If the central controller 302 determines that the rate of change is greater than a threshold value, the central controller 302 determines that the user has either transitioned into or out of the bed 301. If the rate of change is negative, then the central controller determines that the user has gotten out of bed. In this manner, the central controller can detect the presence or absence of a user.

[0059] In some examples, the central controller 302 can confirm the presence of the user in the bed 301, as shown in the optional steps 606-610 of FIG. 6. To determine that the user remains in the bed 301, the central controller 302 determines rolling average values, for example, based on the measured air pressure values (606). The central controller 302 calculates a difference value between the rolling average values and determines a pressure change based on calculated differences (608). The central controller 302 compares the determined pressure change to a threshold value, e.g., stored in a memory device, and determines that the user is moving if the determined pressure change is above the threshold value (610). The threshold value may be a static value, e.g., a specified or fixed value, or a dynamic value, e.g., a value that adjusts over time.

[0060] In some examples, the central controller 302 can detect user presence using instantaneous pressure changes. Then, presence can be verified via the detection of known biometric signals, for example.

[0061] In one example implementation, the central controller 302 can detect user presence using temperature changes detected in the mattress, e.g., using one or more temperature sensors positioned in or on the mattress. The temperature sensors and the central controller 302 can detect a rise in temperature, e.g., over a specified period of time, and determine that a user is present in the bed. For example, if the central controller 302 detects

a rise in temperature and then determines that the detected rise in temperature was not caused by the system's temperature controller 308, the central controller 302 can determine that the user is present.

[0062] In addition to the techniques described above, this disclosure is directed to techniques for detecting a sleeping position of a user of the bed 301, e.g., lying on a side, lying on a back, lying on a front. In one example implementation, the central controller 302 can determine a sleeping position of the user by first detecting user movement, e.g., via changes in a rolling average, and then a gross pressure change, as described in more detail below.

[0063] In one example implementation, the central controller 302 can execute instructions that cause the pressure transducer 46 to measure air pressure values at a sample rate. In one example, the central controller 302 can store the sampled air pressure values in a memory device. Using a moving (or rolling) average, for example, the central controller 302 can determine average (or other central tendency) air pressure values and then determine whether the user has moved on the air mattress based on the rolling average. That is, when the user is stationary, the rolling average will be substantially constant, e.g., no pressure changes. When the user moves, e.g., rolls to the side, the air pressure values may fluctuate, thereby changing the value of the rolling average. The central controller 302 can calculate a difference between the rolling average values and determine that the user is moving based on the calculated difference.

[0064] Once the movement has substantially stopped, the central controller 302 can determine a gross pressure change from the measured air pressure values to determine whether the user is on their side, back, or front. That is, because the pressure in an air mattress is different depending on whether the user is lying on their side, back, or front, the central controller 302 can determine a gross pressure change based on the air pressure in the air mattress before and after the detected movement. If the gross pressure change is positive and within a range of values, then the central controller 302 determines that the user has moved from their back to their side, for example. If the gross pressure change is negative and within a range of values, then the central controller 302 determines that the user has moved from their side to their back, for example. In this manner, the central controller 302 can determine a sleeping position of a user.

[0065] In addition, the central controller 302 can use biometric data to determine a sleeping position of the user. That is, because the received respiration rate signal, heart rate signal, and/or other biometric signals of the user may be different depending on whether the user is lying on their side, back, or front, the central controller 302 can determine a sleeping position based on the received biometric signals.

[0066] FIG. 7 is a flow diagram depicting an example method of detecting the presence of a user of an air mattress. In FIG. 7, the central controller 302 executes in-

structions that cause the pressure transducer 46 to measure air pressure values at a sample rate (700). The central controller 302 determines rolling average values, for example, based on the measured air pressure values (702). The central controller 302 calculates a difference value between the rolling average values and determines a pressure change based on calculated differences (704). The central controller 302 compares the determined pressure change to a threshold value, e.g., stored in a memory device, and determines that the user is moving, e.g., from their front to their side, if the determined pressure change is above the threshold value (706).

[0067] The central controller 302 determines a gross pressure change value, for example, based on the measured air pressure values (708) before and after the user movement. Then, the central controller 302 compares the determined gross pressure change to a range of values (710). If the gross pressure change is positive and within the range of values, then the central controller 302 determines that the user has moved from their back to their side, for example. If the gross pressure change is negative and within a range of values, then the central controller 302 determines that the user has moved from their side to their back, for example. In this manner, the central controller 302 can determine a sleeping position of a user.

Claims

1. A method comprising:

receiving, at a central controller (302) of an air mattress system, a plurality of air pressure values;
determining (502) a plurality of average values using the plurality of the received air pressure values;
calculating (504) a difference value between a first one of the plurality of average values and a second one of the plurality of average values;
comparing the difference value to a threshold value;
determining (506), based on the comparison, whether a user of the air mattress system moved;
initiating a timer upon determining that the user of the air mattress system moved; and
stopping the timer upon determining that the user of the air mattress system has stopped moving,
wherein an accumulated time in the timer represents a total amount of time that the user has moved.

2. The method of claim 1, wherein the average values are rolling average values.

3. The method of claim 1, determining a sleep quality index based on the accumulated time.
4. The method of claim 3, further comprising:
 5 upon determining the sleep quality index, displaying the index to the user.
5. The method of any one of claims 1 to 4, wherein the method is for determining restlessness of the user of the air mattress system (300). 10
6. A method comprising:
 15 detecting whether a user is present on an air mattress, comprising:
 20 receiving, at a central controller (302) of an air mattress system, a plurality of air pressure values;
 25 determining (602) a rate of air pressure change using the plurality of the received air pressure values;
 30 comparing (604) the determined rate of air pressure change to a threshold value; and determining (606), based on the comparison, whether a user of the air mattress transitioned out of and left the air mattress or transitioned onto and is now on the air mattress.
7. The method of claim 1, wherein:
 35 determining the plurality of average values comprises determining a plurality of rolling average values;
 40 calculating the difference value comprises calculating a difference value between a first one of the plurality of rolling average values and a second one of the plurality of rolling average values; and
 45 the method further comprises calculating a pressure change value using a difference between a first one of the plurality of the air pressure values received prior to the user movement beginning and a second one of the plurality of the air pressure values received after the user movement has terminated,
 50 comparing the calculated pressure change value to a threshold value, and determining, based on the comparison, a position of the user of the air mattress system.
8. A bed system (10, 300) comprising: 55
 an inflatable air mattress;
 an adjustable foundation;
- a pump (20, 305); and
 a central controller (302) comprising
 a processor (36, 402) configured to:
 receive a plurality of air pressure values;
 determine a plurality of average values using the plurality of the received air pressure values;
 calculate a difference value between a first one of the plurality of average values and a second one of the plurality of average values;
 compare the difference value to a threshold value; and
 determine, based on the comparison, whether a user of the air mattress system moved
 initiate a timer upon determining that the user of the air mattress system moved; and
 stop the timer upon determining that the user of the air mattress system has stopped moving,
 wherein an accumulated time in the timer represents a total amount of time that the user has moved.
9. The system of claim 8, wherein the average values are rolling average values.
10. The system of claim 9, wherein the processor is configured to determine a sleep quality index based on the accumulated time.
11. The system of claim 10, wherein the processor is configured to:
 upon determining the sleep quality index, display the index to the user.
12. A bed system (10, 300) comprising:
 an inflatable air mattress;
 an adjustable foundation;
 a pump (20, 305); and
 a central controller (302) comprising a processor (36, 402) configured to detect whether a user is present on the air mattress, the detection comprising:
 receive a plurality of air pressure values;
 determine a rate of air pressure change using the plurality of the received air pressure values;
 compare the determined rate of air pressure change to a threshold value; and
 determine, based on the comparison, whether a user of the air mattress transitioned out of and left the air mattress or transitioned onto and is now on the air mattress.

sitioned onto and is now on the air mattress.

13. The bed system of claim 8, wherein the processor is configured to:

determine the plurality of average values by determining a plurality of rolling average values using the plurality of the received air pressure values;
 calculate the difference value by calculating a difference value between a first one of the plurality of rolling average values and a second one of the plurality of rolling average values;
 calculate a pressure change value using a difference between a first one of the plurality of the air pressure values received prior to the user movement beginning and a second one of the plurality of the air pressure values received after the user movement has terminated;
 compare the calculated pressure change value to a threshold value; and
 determine, based on the comparison, a position of the user of the air mattress system.

Patentansprüche

1. Verfahren, das die folgenden Schritte umfasst:

Empfangen von mehreren Luftdruckwerten bei einer zentralen Steuerung (302) eines Luftmatratzensystems;
 Bestimmen (502) von mehreren Mittelwerten unter Verwendung der mehreren empfangenen Luftdruckwerte;
 Berechnen (504) eines Differenzwerts zwischen einem ersten der mehreren Mittelwerte und einem zweiten der mehreren Mittelwerte;
 Vergleichen des Differenzwerts mit einem Schwellenwert;
 Feststellen (506) auf der Basis des Vergleichs, ob sich ein Benutzer des Luftmatratzensystems bewegt;
 Starten eines Zeitmessers bei der Feststellung, dass sich der Benutzer des Luftmatratzensystems bewegt; und
 Stoppen des Zeitmessers bei der Feststellung, dass der Benutzer des Luftmatratzensystems aufgehört hat, sich zu bewegen, wobei eine akkumulierte Zeit in dem Zeitmesser eine Gesamtzeitdauer darstellt, in der sich der Benutzer bewegt hat.

2. Verfahren nach Anspruch 1, wobei die Mittelwerte gleitende Mittelwerte sind.
 3. Verfahren nach Anspruch 1, das einen Schlafqualitätsindex auf der Basis der akkumulierten Zeit be-

stimmt.

4. Verfahren nach Anspruch 3, das ferner den folgenden Schritt umfasst:

beim Bestimmen des Schlafqualitätsindex Anzeigen des Index für den Benutzer.

5. Verfahren nach einem der Ansprüche 1 bis 4, wobei das Verfahren zur Bestimmung der Ruhelosigkeit des Benutzers des Luftmatratzensystems (300) dient.

6. Verfahren, das die folgenden Schritte umfasst:

Detektieren, ob sich ein Benutzer auf einer Luftmatratze befindet, wobei das Verfahren die folgenden Schritte umfasst:

Empfangen von mehreren Luftdruckwerten bei einer zentralen Steuerung (302) eines Luftmatratzensystems;
 Bestimmen (602) einer Luftdruck-Änderungsrate unter Verwendung der mehreren empfangenen Luftdruckwerte;
 Vergleichen (604) der bestimmten Luftdruck-Änderungsrate mit einem Schwellenwert; und
 Feststellen (606) auf der Basis des Vergleichs, ob ein Benutzer der Luftmatratze wechselt und die Luftmatratze verlassen hat oder wechselt und sich nun auf der Luftmatratze befindet.

7. Verfahren nach Anspruch 1, wobei:

das Bestimmen der mehreren Mittelwerte das Bestimmen von mehreren gleitenden Mittelwerten umfasst;
 das Berechnen des Differenzwerts das Berechnen eines Differenzwerts zwischen einem ersten der mehreren gleitenden Mittelwerte und einem zweiten der mehreren gleitenden Mittelwerte umfasst; und
 das Verfahren ferner die folgenden Schritte umfasst:

Berechnen eines Druckänderungswerts unter Verwendung einer Differenz zwischen einem ersten der mehreren Luftdruckwerte, der vor dem Beginn der Bewegung des Benutzers empfangen wurde, und einem zweiten der mehreren Luftdruckwerte, der empfangen wurde, nachdem die Bewegung des Benutzers aufgehört hat, Vergleichen des berechneten Druckänderungswerts mit einem Schwellenwert, und Bestimmen auf der Basis des Vergleichs ei-

- ner Position des Benutzers des Luftmatratzensystems.
8. Bettssystem (10, 300), das Folgendes umfasst:
- eine aufblasbare Luftmatratze;
 - einen einstellbaren Sockel;
 - eine Pumpe (20, 305); und
 - eine zentrale Steuerung (302), die Folgendes umfasst:
- einen Prozessor (36, 402), der ausgelegt ist zu Folgendem:
 - Empfangen von mehreren Luftdruckwerten;
 - Bestimmen von mehreren Mittelwerten unter Verwendung der mehreren empfangenen Luftdruckwerte;
 - Berechnen eines Differenzwerts zwischen einem ersten der mehreren Mittelwerte und einem zweiten der mehreren Mittelwerte;
 - Vergleichen des Differenzwertes mit einem Schwellenwert; und
 - Feststellen auf der Basis des Vergleichs, ob sich ein Benutzer des Luftmatratzensystems bewegt hat,
 - Starten eines Zeitmessers bei der Feststellung, dass sich der Benutzer des Luftmatratzensystems bewegt hat; und
 - Stoppen des Zeitmessers bei der Feststellung, dass der Benutzer des Luftmatratzensystems aufgehört hat, sich zu bewegen,
- wobei eine akkumulierte Zeit in dem Zeitmesser eine Gesamtzeitdauer darstellt, in der sich der Benutzer bewegt hat.
9. System nach Anspruch 8, wobei die Mittelwerte gleitende Mittelwerte sind.
10. System nach Anspruch 9, wobei der Prozessor ausgelegt ist, einen Schlafqualitätsindex auf der Basis der akkumulierten Zeit zu bestimmen.
11. System nach Anspruch 10, wobei der Prozessor ausgelegt ist, beim Bestimmen des Schlafqualitätsindex den Index für den Benutzer anzuzeigen.
12. Bettssystem (10, 300), das Folgendes umfasst:
- eine aufblasbare Luftmatratze;
 - einen einstellbaren Sockel;
 - eine Pumpe (20, 305); und
 - eine zentrale Steuerung (302), die einen Prozessor (36, 402) umfasst, der ausgelegt ist, zu
- detektieren, ob sich ein Benutzer auf der Luftmatratze befindet, wobei das Detektieren die folgenden Schritte umfasst:
- Empfangen von mehreren Luftdruckwerten;
 - Bestimmen einer Luftdruck-Änderungsrate unter Verwendung der mehreren empfangenen Luftdruckwerte;
 - Vergleichen der bestimmten Luftdruck-Änderungsrate mit einem Schwellenwert; und
 - Feststellen auf der Basis des Vergleichs, ob ein Benutzer der Luftmatratze wechselt und die Luftmatratze verlassen hat oder wechselt und sich nun auf der Luftmatratze befindet.
13. Bettssystem nach Anspruch 8, wobei der Prozessor für die folgenden Schritte ausgelegt ist:
- Bestimmen der mehreren Mittelwerte durch Bestimmen von mehreren gleitenden Mittelwerten unter Verwendung der mehreren empfangenen Luftdruckwerte;
 - Berechnen des Differenzwerts durch Berechnen eines Differenzwerts zwischen einem ersten der mehreren gleitenden Mittelwerte und einem zweiten der mehreren gleitenden Mittelwerte;
 - Berechnen eines Druckänderungswerts unter Verwendung einer Differenz zwischen einem ersten der mehreren Luftdruckwerte, der vor dem Beginn der Bewegung des Benutzers empfangen wurde, und einem zweiten der mehreren Luftdruckwerte, der empfangen wurde, nachdem die Bewegung des Benutzers aufgehört hat;
 - Vergleichen des berechneten Druckänderungswerts mit einem Schwellenwert; und
 - Bestimmen auf der Basis des Vergleichs einer Position des Benutzers des Luftmatratzensystems.
- Revendications**
1. Procédé consistant à :
- recevoir, au niveau d'un contrôleur central (302) d'un système de matelas pneumatique, une pluralité de valeurs de pression d'air ;
 - déterminer (502) une pluralité de valeurs moyennes au moyen de la pluralité des valeurs de pression d'air reçues ;
 - calculer (504) une valeur de différence entre une première valeur moyenne de la pluralité de valeurs moyennes et une seconde valeur moyenne de la pluralité de valeurs moyennes ; com-

- parer la valeur de différence à une valeur de seuil ;
détérminer (506), sur la base de la comparaison, si un utilisateur du système de matelas pneumatique a bougé ;
démarrer une minuterie lorsqu'il est déterminé que l'utilisateur du système de matelas pneumatique a bougé ; et
arrêter la minuterie lorsqu'il est déterminé que l'utilisateur du système de matelas pneumatique a arrêté de bouger,
un temps cumulé dans le minuteur représentant une durée totale pendant laquelle l'utilisateur a bougé.
2. Procédé selon la revendication 1, dans lequel les valeurs moyennes sont des valeurs moyennes mobiles.
3. Procédé selon la revendication 1, consistant à déterminer un indice de qualité de sommeil sur la base du temps cumulé.
4. Procédé selon la revendication 3, consistant en outre à :
- à la détermination de l'indice de qualité de sommeil, afficher l'indice à l'utilisateur.
5. Procédé selon l'une quelconque des revendications 1 à 4, le procédé consistant à déterminer une agitation de l'utilisateur du système de matelas pneumatique (300).
6. Procédé consistant à :
- détecter si un utilisateur est présent sur un matelas pneumatique, ce qui consiste à :
- recevoir, au niveau d'un contrôleur central (302) d'un système de matelas pneumatique, une pluralité de valeurs de pression d'air ;
déterminer (602) un taux de variation de pression d'air au moyen de la pluralité des valeurs de pression d'air reçues ;
comparer (604) le taux déterminé de variation de pression d'air à une valeur de seuil ;
et
déterminer (606), sur la base de la comparaison, si un utilisateur du matelas d'air abandonne et quitte le matelas pneumatique ou se place sur le matelas d'air et est maintenant dessus.
7. Procédé selon la revendication 1, dans lequel :
- la détermination de la pluralité de valeurs

moyennes consiste à déterminer une pluralité de valeurs moyennes mobiles ;
le calcul de la valeur de différence consiste à calculer une valeur de différence entre une première valeur moyenne mobile de la pluralité de valeurs moyennes mobiles et une seconde valeur moyenne mobile de la pluralité de valeurs moyennes mobiles ; et
le procédé consistant en outre à :

calculer une valeur de variation de pression au moyen d'une différence entre une première valeur de pression d'air de la pluralité des valeurs de pression d'air reçues avant que l'utilisateur n'ait commencé à bouger et une seconde valeur de pression d'air de la pluralité des valeurs de pression d'air reçues après que l'utilisateur a fini de bouger ;
comparer la valeur de variation de pression calculée à une valeur de seuil ; et
déterminer, sur la base de la comparaison, une position de l'utilisateur du système de matelas pneumatique.

8. Système de lit (10, 300) comprenant :

un matelas pneumatique gonflable ;
une base réglable ;
une pompe (20, 305) ; et
un contrôleur central (302) comprenant un processeur (36, 402) conçu pour :

recevoir une pluralité de valeurs de pression d'air ;
déterminer une pluralité de valeurs moyennes au moyen de la pluralité des valeurs de pression d'air reçues ;
calculer une valeur de différence entre une première valeur moyenne de la pluralité de valeurs moyennes et une seconde valeur moyenne de la pluralité de valeurs moyennes ;
comparer la valeur de différence à une valeur de seuil ; et
déterminer, sur la base de la comparaison, si un utilisateur du système de matelas pneumatique a bougé ;

démarrer une minuterie lorsqu'il est déterminé que l'utilisateur du système de matelas pneumatique a bougé ; et
arrêter la minuterie lorsqu'il est déterminé que l'utilisateur du système de matelas pneumatique a arrêté de bouger,
un temps cumulé dans le minuteur représentant une durée totale pendant laquelle l'utilisateur a bougé.

9. Système selon la revendication 8, dans lequel les valeurs moyennes sont des valeurs moyennes mobiles.
10. Système selon la revendication 9, dans lequel le processeur est conçu pour déterminer un indice de qualité de sommeil sur la base du temps cumulé. 5
11. Système selon la revendication 10, dans lequel le processeur est conçu pour : à la détermination de l'indice de qualité de sommeil, afficher l'indice à l'utilisateur. 10
12. Système de lit (10, 300) comprenant : 15
- un matelas pneumatique gonflable ;
 - une base réglable ;
 - une pompe (20, 305) ; et
 - un contrôleur central (302) comprenant un processeur (36, 402) conçu pour détecter si un utilisateur est présent sur le matelas pneumatique, la détection consistant à : 20
 - recevoir une pluralité de valeurs de pression d'air ; 25
 - déterminer un taux de variation de pression d'air au moyen de la pluralité des valeurs de pression d'air reçues ;
 - comparer le taux déterminé de variation de pression d'air à une valeur de seuil ; et 30
 - déterminer, sur la base de la comparaison, si un utilisateur du matelas d'air abandonne et quitte le matelas pneumatique ou se place sur le matelas d'air et est maintenant dessus. 35
13. Système de lit selon la revendication 8, dans lequel le processeur est conçu pour :
- déterminer la pluralité de valeurs moyennes en déterminant une pluralité de valeurs moyennes mobiles au moyen de la pluralité des valeurs de pression d'air reçues ; 40
 - calculer la valeur de différence en calculant une valeur de différence entre une première valeur moyenne mobile de la pluralité de valeurs moyennes mobiles et une seconde valeur moyenne mobile de la pluralité de valeurs moyennes mobiles ; 45
 - calculer une valeur de variation de pression au moyen d'une différence entre une première valeur de pression d'air de la pluralité des valeurs de pression d'air reçues avant que l'utilisateur n'ait commencé à bouger et une seconde valeur de pression d'air de la pluralité des valeurs de pression d'air reçues après que l'utilisateur a fini de bouger ; 50
 - comparer la valeur de variation de pression cal-

culée à une valeur de seuil ; et déterminer, sur la base de la comparaison, une position de l'utilisateur du système de matelas pneumatique.

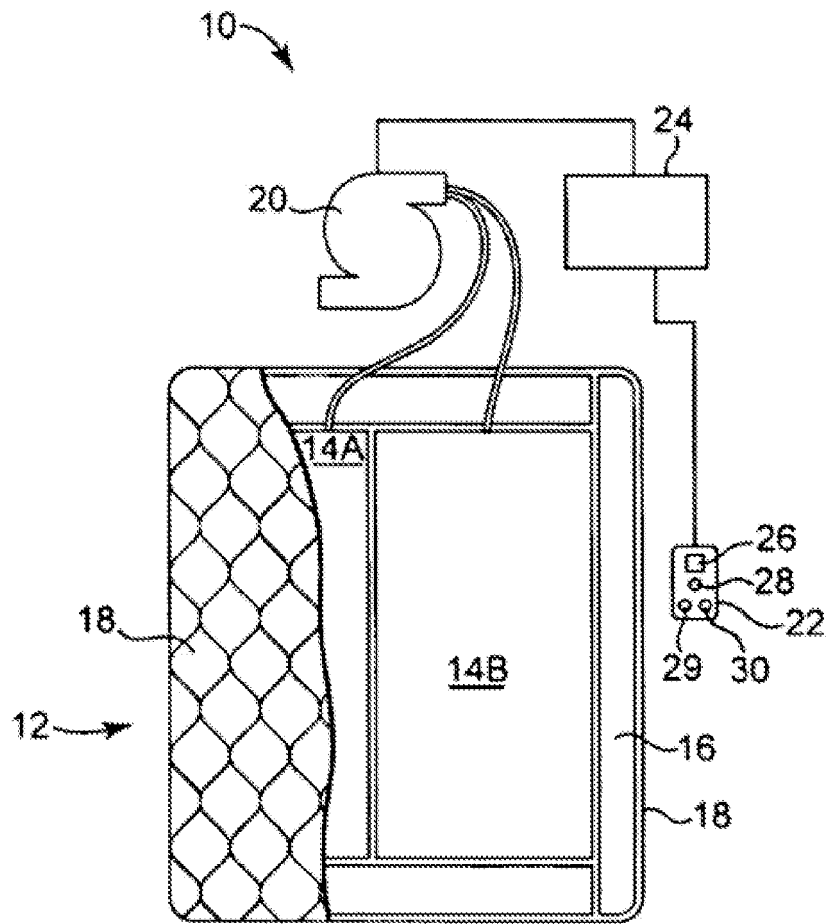

Fig. 1

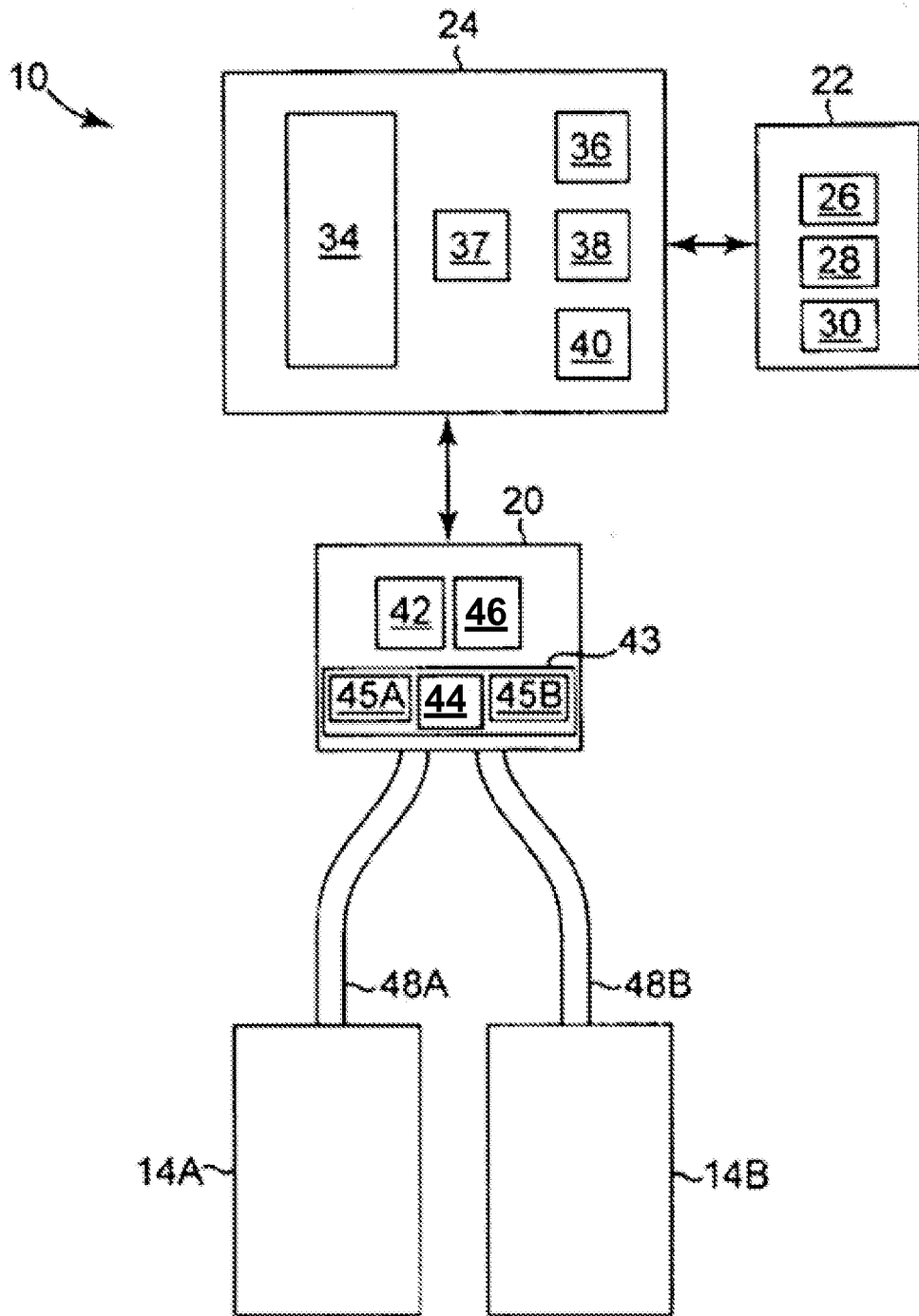

Fig. 2

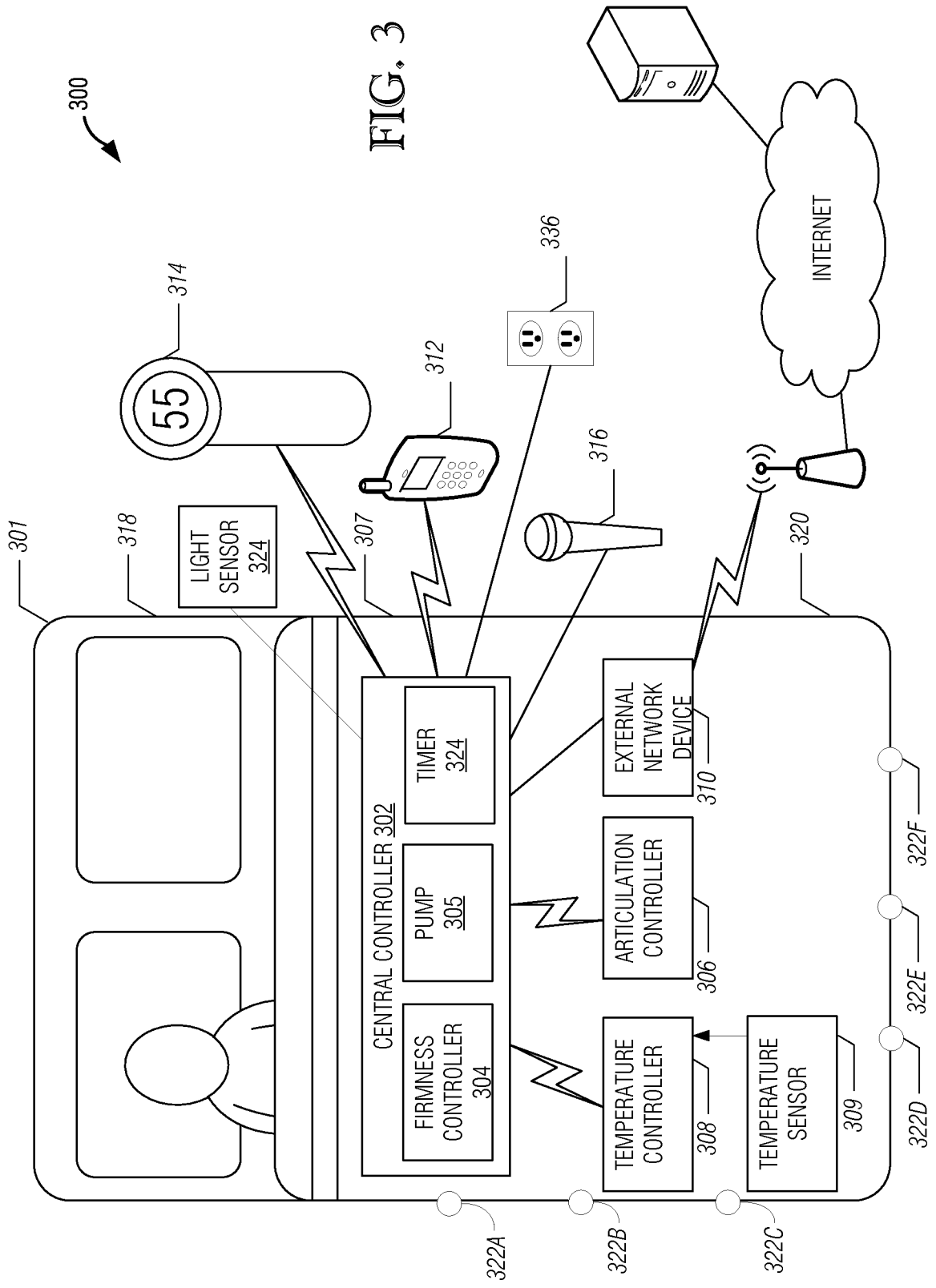

FIG. 3

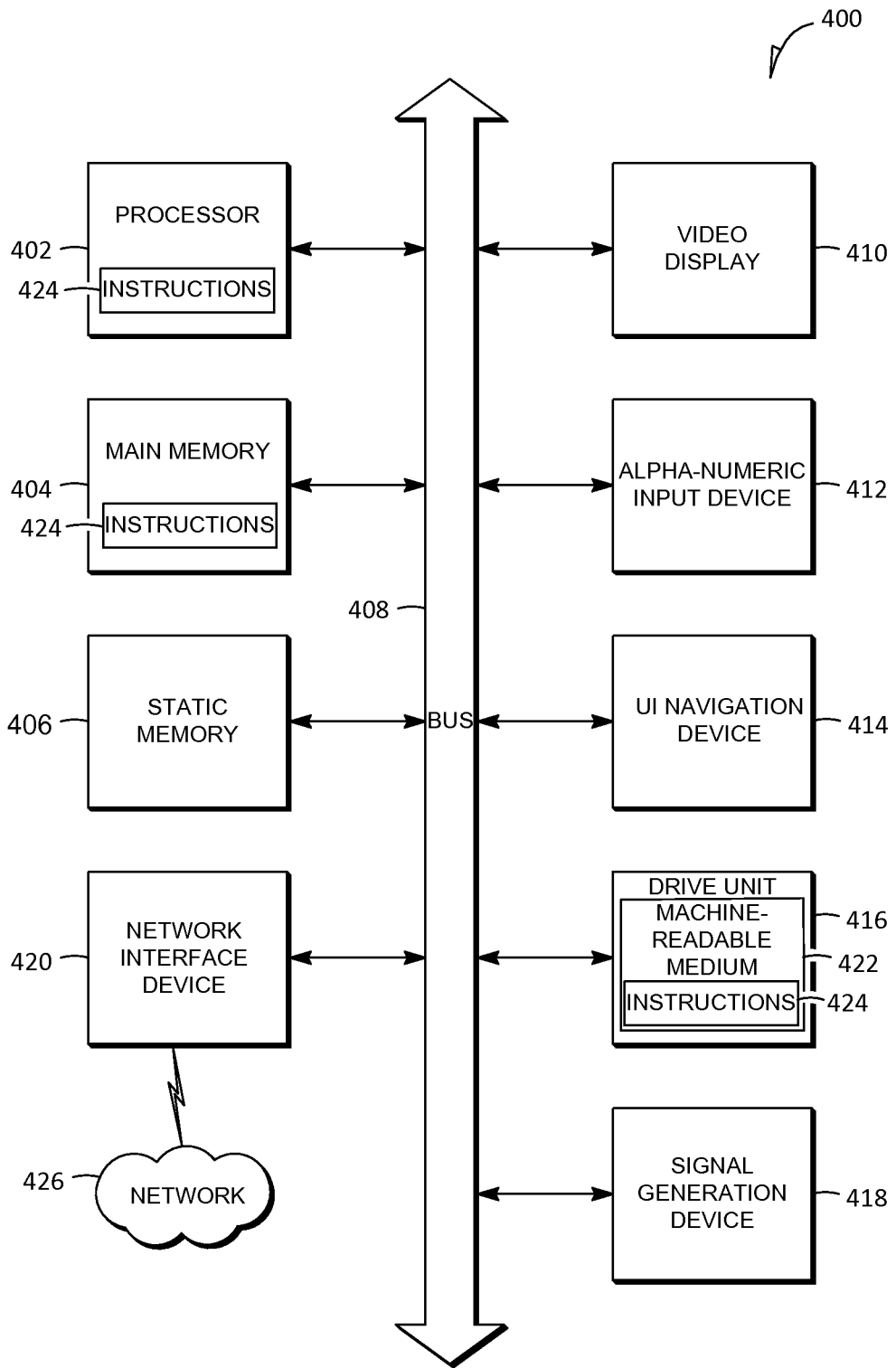

FIG. 4

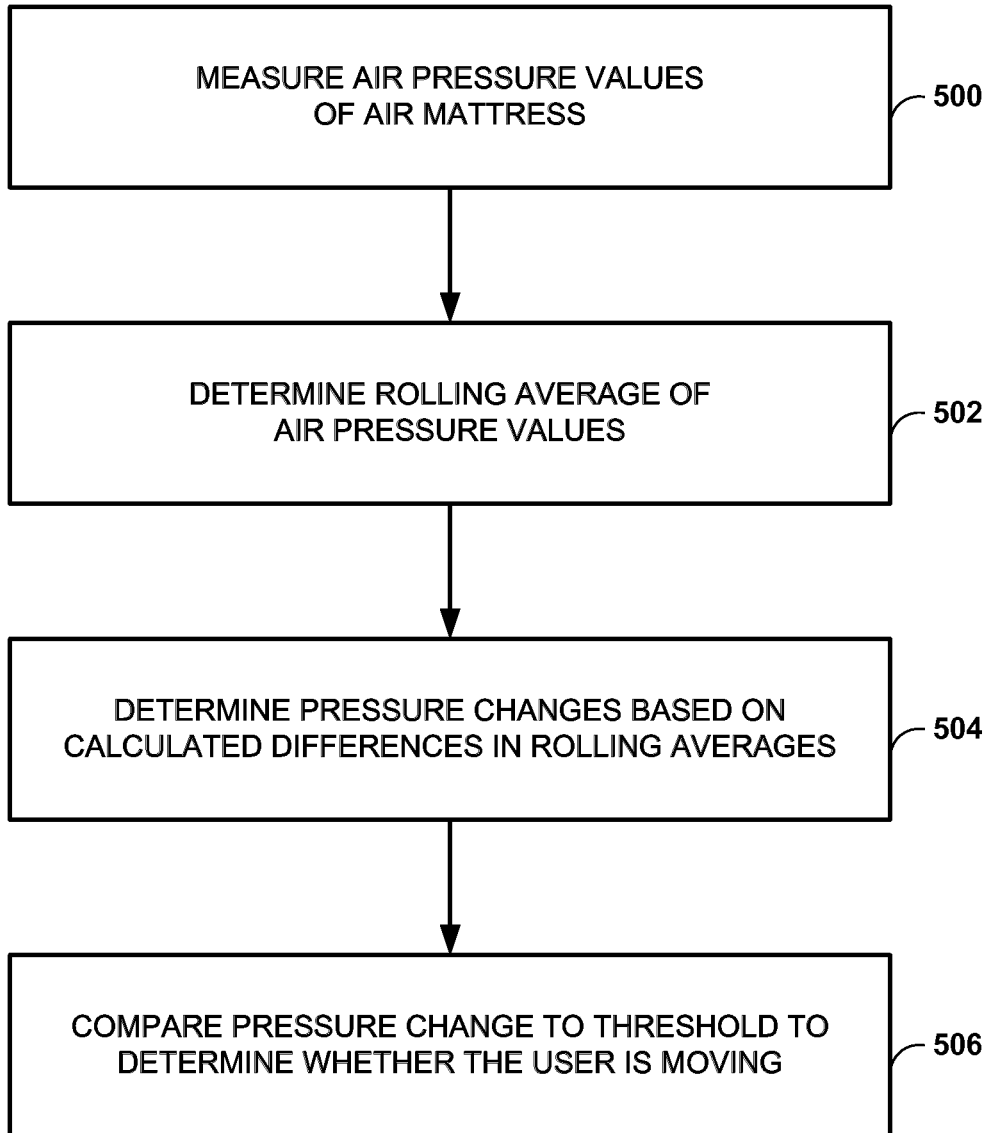

FIG. 5

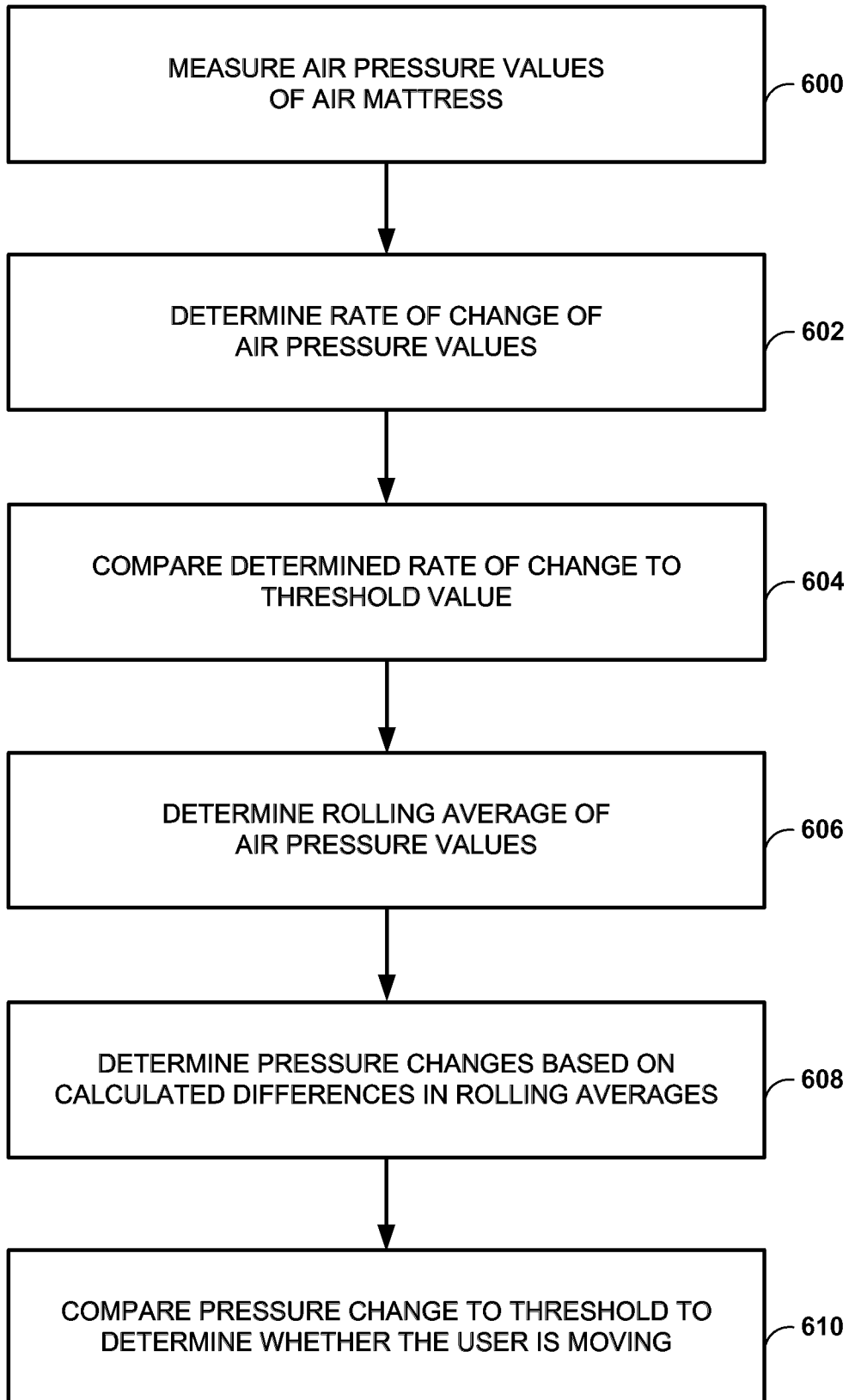

FIG. 6

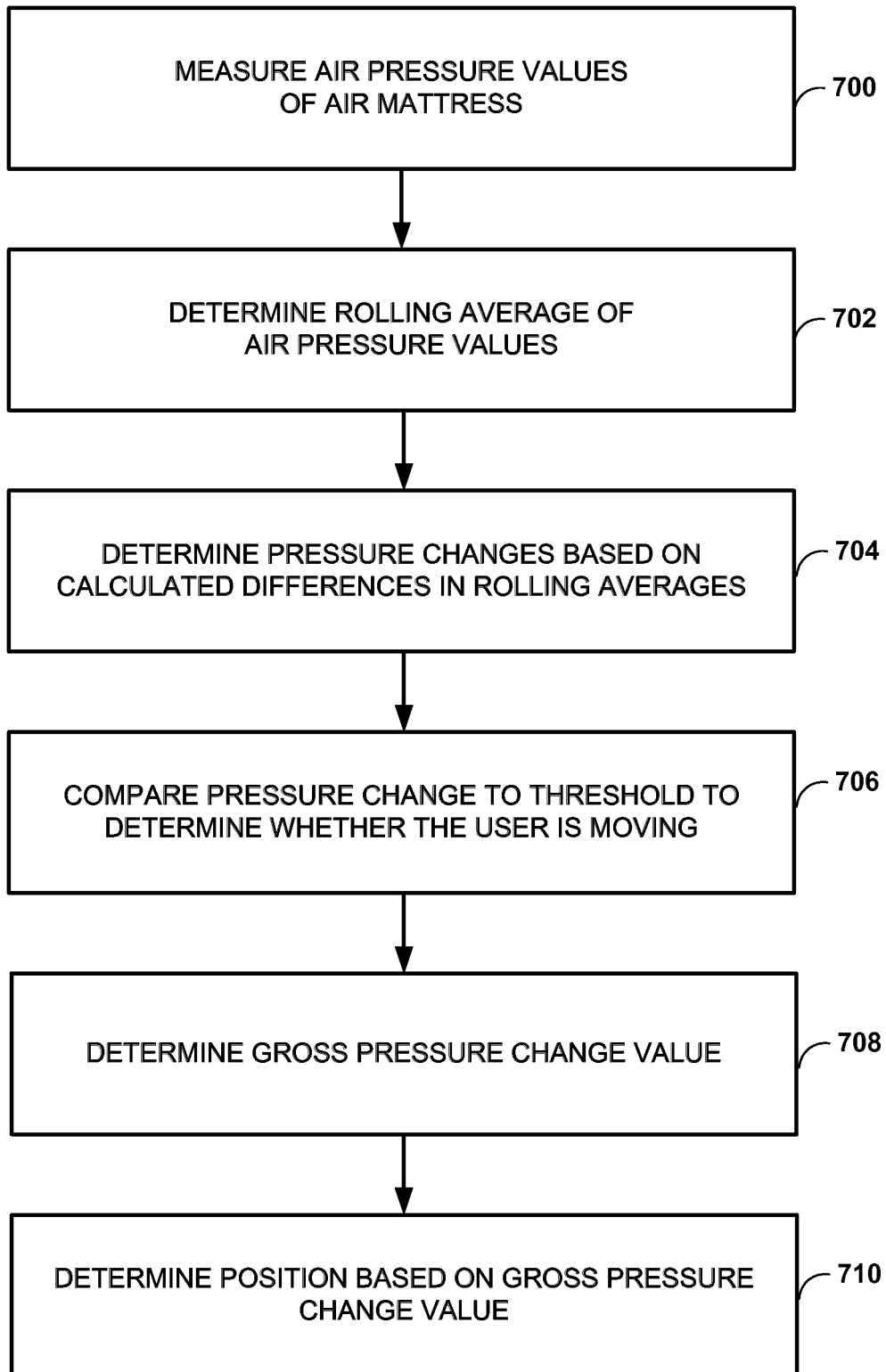

FIG. 7

REFERENCES CITED IN THE DESCRIPTION

This list of references cited by the applicant is for the reader's convenience only. It does not form part of the European patent document. Even though great care has been taken in compiling the references, errors or omissions cannot be excluded and the EPO disclaims all liability in this regard.

Patent documents cited in the description

- US 61781311 A [0001]
- US 61781266 A [0002]
- US 61781503 A [0002]
- US 61781541 A [0002]
- US 61781571 A [0002]
- US 61782394 A [0002]
- US 61781296 A [0002]
- US 5904172 A [0004]
- WO 2009108228 A [0006]
- US 20110015495 A [0007]
- US 20030221261 A [0008]
- US 936084 A [0020]
- US 20100170043 A, Steven J. Young [0052]

专利名称(译)	充气床垫系统，带检测技术		
公开(公告)号	EP2967224A1	公开(公告)日	2016-01-20
申请号	EP2014716711	申请日	2014-03-13
[标]申请(专利权)人(译)	Select Comfort的 BAM LABS		
申请(专利权)人(译)	Select Comfort的CORPORATION BAM实验室，Inc.		
当前申请(专利权)人(译)	Select Comfort的CORPORATION BAM实验室，Inc.		
[标]发明人	NUNN ROB PALASHEWSKI WADE DANIEL TILSTRA MATTHEW WAYNE YOUNG STEVEN HEWITT CARL ZHOVNIROVSKY YURI		
发明人	NUNN, ROB PALASHEWSKI, WADE DANIEL TILSTRA, MATTHEW WAYNE YOUNG, STEVEN HEWITT, CARL ZHOVNIROVSKY, YURI		
IPC分类号	A47C27/08 A47C31/12 A61B5/11 A61B5/00		
代理机构(译)	康罗伊，JOHN		
优先权	61/781311 2013-03-14 US		
其他公开文献	EP2967224B1		
外部链接	Espacenet		

摘要(译)

在一个示例中，本公开描述了一种方法，包括在气垫系统的中央控制器处接收多个气压值，使用多个接收的气压值确定多个平均值，计算两者之间的差值。在多个平均值中的第一个和多个平均值中的第二个中，将差值与阈值进行比较，基于该比较确定气垫系统的用户是否移动。