

(19)



(11)

EP 2 898 326 B1

(12)

EUROPEAN PATENT SPECIFICATION

(45) Date of publication and mention of the grant of the patent:
14.03.2018 Bulletin 2018/11

(51) Int Cl.:
G01N 33/48 (2006.01) A61B 5/1455 (2006.01)
A61B 5/00 (2006.01)

(21) Application number: **13852589.4**

(86) International application number:
PCT/US2013/068956

(22) Date of filing: **07.11.2013**

(87) International publication number:
WO 2014/074720 (15.05.2014 Gazette 2014/20)

(54) **EFFICIENT MODULATED IMAGING**

EFFIZIENTE MODULIERTE ABBILDUNG

IMAGERIE MODULÉE EFFICACE

(84) Designated Contracting States:
AL AT BE BG CH CY CZ DE DK EE ES FI FR GB GR HR HU IE IS IT LI LT LU LV MC MK MT NL NO PL PT RO RS SE SI SK SM TR

- **MAZHAR, Amaan**
Irvine
California 92617 (US)

(30) Priority: **07.11.2012 US 201261723721 P**
15.03.2013 US 201361793331 P

(74) Representative: **Hanna Moore + Curley**
Garryard House
25/26 Earlsfort Terrace
Dublin 2, D02 PX51 (IE)

(43) Date of publication of application:
29.07.2015 Bulletin 2015/31

(56) References cited:
WO-A1-00/20843 US-A1- 2003 023 172
US-A1- 2003 023 172 US-A1- 2006 029 350
US-A1- 2006 029 350 US-A1- 2006 247 532
US-A1- 2010 049 056 US-A1- 2010 210 931
US-A1- 2011 124 988 US-B2- 6 958 815
US-B2- 7 418 118 US-B2- 7 418 118

(73) Proprietor: **Modulated Imaging Inc.**
Irvine, California 92612 (US)

(72) Inventors:
• **CUCCIA, David**
Costa Mesa
California 92627 (US)

EP 2 898 326 B1

Note: Within nine months of the publication of the mention of the grant of the European patent in the European Patent Bulletin, any person may give notice to the European Patent Office of opposition to that patent, in accordance with the Implementing Regulations. Notice of opposition shall not be deemed to have been filed until the opposition fee has been paid. (Art. 99(1) European Patent Convention).

Description

FIELD

[0001] The embodiments described herein generally relate to modulated imaging for quantitative characterization of tissue structure and function and, more particularly, to systems and methods that facilitate efficient modulated imaging.

BACKGROUND

[0002] Quantitative characterization of tissue structure and function is one of the most challenging problems in medical imaging. Diffuse optical methods can be used to measure biological tissues or other turbid (i.e. light-scattering) samples with resolution and depth sensitivity from microns to centimeter length scales, limited by fundamental light-tissue interactions. Important tissue components (referred to as chromophores) such as oxy-hemoglobin, deoxy-hemoglobin and water can be detected optically and correlate to various indicators or indices of local tissue health or physiological status. Examples of such indices include the tissue oxygen saturation (stO₂, or fraction of oxygenated blood), total blood volume (ct-Hb), tissue water fraction (ctH₂O), and tissue perfusion or metabolism. These indices can provide a powerful means for physicians to perform diagnoses and/or guide therapies. These chromophores can be detected because they have absorption spectra with detectable features, in the visible and/or near infrared regions. In essence, a light source can be used to illuminate a tissue sample, and the remitted light can be used to measure the absorption features in tissue and quantify the chromophore of interest. Practically, this is a difficult measurement due to the presence of scattering in tissue. A class of probe-based technologies have been described in academia and have also been translated commercially by a number of companies (Somanetics, Hutchinson, Vi-Optix). Each of these technologies use a number of different algorithms and hardware components (illumination sources, spectral detection) to approach the problem to account, correct, or control for tissue scattering to derive meaningful information about hemoglobin and tissue oxygenation. These probes take advantage of the large selection of single point detectors that enable spectral flexibility and high sensitivity. However, contact probes suffer from some major limitations. By nature, contact probes are not imaging technologies and thus not ideal for assessing large areas of tissue. This is important because tissue health is often spatially variant, for example, in tissue wounds (burns, ulcers, skin flaps, etc.), where spatial contrast can be present both between normal tissue and the wound, as well as within the wound itself (e.g. wound boundary vs. wound center). With contact probes, in order to synthesize a low resolution image, multiple contact probes must be placed in a number of tissue locations, or the probe must be scanned across

the surface. Typical wounds can vary from a few mm in size to many cm, presenting a challenge for probe technologies to design for, address, and/or adapt to this large range.

[0003] Camera based optical spectral imaging methods have also been developed in academia and commercially. A multi-spectral imaging technology using visible light (HyperMed) has been applied to measure tissue oxygenation over a wide field of view (~ 10cm x 10 cm) and has been applied to monitoring of diabetic wounds. Multi-spectral imaging methods typically employ wavelengths which sample only top superficial (<1mm deep) layers of tissue. While near-infrared (650-1000nm) penetrates much more deeply, the chromophore contrast in the reflected or transmitted light signal is more challenging to isolate and quantify, due to the presence of a strong tissue scattering coefficient (i.e. compared to absorption). A technology that can overcome this limitation and assesses tissue health over a wide field of view in a non-contact manner both in superficial layers (~100um deep) layer as well as subsurface layers (1-10mm) is more valuable and is therefore desired.

[0004] A novel optical imaging method called Modulated Imaging (MI), which enables quantitative analysis of disease progression and therapeutic response in a wide field of view and depth of the tissue without requiring direct contact, was recently introduced. MI has been described in US patent 6,958,815 B2, herein referred to as Bevilacqua et al. This technique comprises illuminating biological tissue or other turbid medium (a sample that is both scattering and absorbing) with a spatially modulated light (or "structured light") pattern at one or more optical wavelengths and analyzing the resulting collected back reflected and scattered light from the tissue. A preferred embodiment of MI is called Spatial Frequency Domain Imaging (SFDI), in which the spatial light pattern, or structure, is sinusoidal, which provides an algorithmically simple way of detecting the structured light contrast from a small number (typically 3-15 per wavelength) of structured light measurements. When combined with multi-spectral imaging, the optical properties at two or more wavelengths can be used to quantitatively determine the in-vivo concentrations of chromophores that are relevant to tissue health, e.g. oxy-hemoglobin (ctO₂Hb), deoxy-hemoglobin (ctHHb) and water (ctH₂O).

[0005] In order to perform spectroscopic (wavelength-dependent) measurements of absorbing chromophores, the MI technique requires collection of remitted spatially structured light from tissue at various wavelengths. This has been accomplished to-date by repeating the disclosed technique of Bevilacqua et al for each desired wavelength. *Thus, total imaging times scale directly with the number of wavelengths measured.* This can be particularly challenging for some wavelengths in the near-infrared where illumination sources are less bright, optical throughput is low, and detector quantum efficiencies are low due to CCD limitations. For low throughput wavelengths, long integration times (10s to 100s of ms) are

required to obtain adequate signal to noise ratio. Light intensity must be increased at those wavelengths in order to reduce integration time. However, this is limited by the étendue, or light throughput, limitations of structured light projection hardware, including that of both light source (e.g. LEDs, lasers, white light bulb), optical relay system (e.g. lenses, waveguides, mirrors), and pattern generation technology (e.g. reflective digital micromirror array or liquid-crystal-on-silicon, patterned transmissive material or LCD array, or holographic element). "Brute force" increases in intensity of weak or inefficient wavelength bands can have other effects including increased power consumption, increased thermal stress (which can lead to further source inefficiency and instability) and increased cooling requirements. Longer imaging times also create a practical issue in medical (or other motion-sensitive) applications as it leads to artifacts in the final image due to small movements of the measurement sample (e.g. tissue) under study. It is therefore desirable to provide an apparatus and method that improves the capability of the current modulated imaging methods while maintaining accuracy but improving system efficiency and reducing the imaging time.

[0006] As described briefly above, MI comprises illumination of a sample with one or more spatially structured intensity patterns over a large (many cm^2) area of a tissue (or other turbid) sample and collecting and analyzing the resulting light received back from the sample. An analysis of the amplitude and/or phase of the spatially-structured light received back from the sample as a function of spatial frequency or periodicity, often referred to as the modulation transfer function (MTF) can be used to determine the sample's optical property information at any discrete wavelength. Examples of tissue optical properties include light absorption, light scattering (magnitude and/or angular-dependence), and light fluorescence. Analysis of this light-dependent data (model based or empirically-derived) can be used to generate 2D or 3D maps of the quantitative absorption (μ_a) and reduced scattering (μ_s') optical properties. Region-wise (multi-pixel) assessments can also be produced by averaging or otherwise accumulating multiple spatial optical property or derived results. By using the spatial frequency or periodicity information at various wavelengths, MI can separate absorption (μ_a) and fluorescence (μ_a) from scattering (μ_s) effects, which each result from physically distinct contrast mechanisms.

[0007] Mapping the absorption coefficient, (μ_a), at multiple wavelengths, by MI, in turn, enables quantitative spectroscopy of tissue chromophores including but not limited to oxy- and deoxy-hemoglobin and water (ctO₂Hb, ctHHb, and ctH₂O) and derived physiology parameters such as tissue oxygen saturation and blood volume (stO₂ and ctTHb). The spatially-varying phase of the light collected from the tissue can also be simultaneously measured, and yields topological surface information. This combination of measurements enables visualization of the 3D tissue profile, as well as calibration data for ac-

commodating curved surfaces in the analysis. A typical data flow is shown in Figure 1.

[0008] A present issue in measurement and analysis of MI is imaging time. Longer imaging times increase sensitivity to motion and ambient lighting, which can result in artifacts in the two dimensional maps of the measured biological metrics - particularly in clinical applications. Hardware limitations are a key cause for long imaging times. High power light sources, such as light emitting diodes (LEDs), can ameliorate the issue but measurement time remains an issue in the near infrared. This is because LED power and camera sensitivity can depend strongly on wavelength and LED power is limited by cooling requirements and size of the apparatus.

[0009] Figure 2 shows an example dataset of an infant burn wound, collected with a prior art modulated imaging apparatus which exhibits motion artifacts. Figure 2(b) shows reflectance data versus wavelength and spatial frequency. Note the artifact high spatial frequency striped pattern in the demodulated 970nm data (right, bottom). Here the term demodulated data means the extracted amplitude of the light received from the tissue normalized to the amplitude of the light illumination at each spatial frequency. In other words the demodulated data is the modulation transfer function of the illuminated tissue. These artifacts are due to motion during the long integration times required for this wavelength. As Figure 2(c) highlights, a 10x longer integration time (i.e. 5s) is required to acquire the data set at 970 nm compared to other shorter wavelengths (i.e. only 0.5s). Using all wavelength information to produce chromophore or scattering amplitude/slope measurements results in sinusoidal artifacts in the derived data as shown in average scatter amplitude image in Figure 2(d).

[0010] It has been shown that if the 970nm wavelength measurement (and thus analysis of water concentration (ctH₂O) is excluded ctO₂Hb and ctHHb can still be accurately calculated by assuming a typical tissue water fraction. Figure 2(e) shows the resulting analysis when 970nm data are excluded which correctly identifies a high-scattering region in the upper left corner of the infant's arm, indicated by the black arrow. This region corresponds to the most severe location of the burn and is useful to identify. However, water sensitivity is highly desirable in many studies, so excluding 970 nm data is not desirable.

[0011] In general, therefore, it is desirable to have the flexibility to capture spectral contrast measurements of target chromophores at various wavelengths, while simultaneously having minimal increases in complexity, if any, to the structured light requirements of the core modulated imaging technique. It is therefore desirable to provide an apparatus and a method to remove the effects of artifacts at wavelengths with poor performance/sensitivity in order to provide full information about the concentrations and/or distributions of all relevant components including ctH₂O, ctO₂Hb, ctHHb, and others (e.g. bilirubin, methemoglobin, lipids, exogenous agents).

[0012] The US patent US7418118 B2 describes a system for on-site detection of microscopic contaminants in microscope samples. The US patent document US2006/029350 discloses an integration rod for use in a digital projector. The US patent document US 2003/023172 discloses a technique for measuring broadband near-infrared absorption spectra of turbid media. US 2011/0124988 discloses systems and methods for measurement of scattering and absorption coefficients of a turbid sample.

SUMMARY

[0013] The present application provides an apparatus and method for the measurement of a turbid sample in accordance with the claims which follow.

[0014] The systems, methods, features and advantages of the invention will be or will become apparent to one with skill in the art upon examination of the following figures and detailed description. It is intended that all such additional methods, features and advantages be included within this description, be within the scope of the invention, and be protected by the accompanying claims. It is also intended that the invention is not limited to require the details of the example embodiments.

BRIEF DESCRIPTION OF THE FIGURES

[0015] The accompanying drawings, which are included as part of the present specification, illustrate the presently preferred embodiment and, together with the general description given above and the detailed description of the preferred embodiment given below, serve to explain and teach the principles of the present invention.

Figure 1 shows a flowchart of modulated imaging (MI) data processing and typical MI data products, (a) shows modulated intensity patterns projected onto the surface. (b) shows the patterns amplitude demodulated and calibrated at each frequency (three phase images per frequency), (c) shows the patterns fit to a multi-frequency model to determine optical properties. (d) shows that phase demodulation separately provides information on tissue height, which can be used for both curvature calibration and visualization. Data are processed for each pixel, generating spatial maps of optical properties, (e) shows typical MI data products for a rat pedicle flap, with the distal end demonstrating MI sensitivity to lowered perfusion (stO₂), blood pooling (ctHHb & ctTHb), edema (ctH₂O), and degradation of matrix ultrastructure/necrosis (μ s').

Figure 2 are images that show that long measurement times in a pediatric burn patient cause visible artifacts in raw and recovered MI data. (a) is a photograph of burn tissue under study; (b) are raw data images showing demodulated diffuse reflectance data at spatial frequency = 0.1 mm⁻¹ (bottom) and

spatial frequency = 0 mm⁻¹ (top), for 4 wavelengths, from left to right 658 nm, 730 nm, 850 nm, and 970 nm; (c) highlights that a 10x longer integration time (i.e. 5s) is required to acquire the data set at 970nm compared to other shorter wavelengths (i.e. only 0.5s); (d) is an image showing recovered tissue oxygenation (StO₂) data, from an analysis including 970 nm data, containing data artifacts; (e) is an image showing recovered tissue oxygenation (StO₂) data, from an analysis excluding the demodulated 970 nm data. A black arrow indicates a spatial area of increased oxygenation in the wounded burn region, as compared to the surrounding tissue. This result is obscured in (d) from the motion artifacts associated with the 970nm measurement.

Figure 3 shows an embodiment of an increased efficiency apparatus for modulated imaging, (a) shows a light ring for planar external light illumination, a projection system for structured light illumination, and an off-center camera, (b) shows a light ring pattern and camera showing rectangular structured light field in the center, superimposed by planar light illumination both of which are detected by the camera.

Figure 4 shows a planar light source with 9 positions to be populated with different wavelength LED.

Figure 5 shows a planar illumination light ring with removable LED modules.

Figure 6 is a workflow diagram of an efficient MI analysis using structured and non-structured light.

Figure 7 shows example data showing a comparison between scattering and absorption coefficients obtained from the modulated imaging apparatus described in prior art and the present efficient modulated imaging apparatus and method, (a) is an image of a 'Port Wine Stain (PWS)' imaged with a prior art apparatus. Note that the PWS region on the cheek has a higher stO₂ concentration compared to the surrounding areas due to increased vascularization. (b) is a graph of the scattering coefficient as a function of wavelength comparing prior art (full fit line) and efficient apparatus and method of the present invention (reduced data lines), (c) is a graph of the absorption coefficient as a function of wavelength comparing prior art (full fit line) and efficient apparatus and method of the present invention (reduced data lines)

Figure 8 are graphs showing a comparison of extracted scattering and absorption data from a Port Wine Stain (a) and Burn tissue (b) using the efficient modulated imaging apparatus (y axis) versus using prior art modulated imaging apparatus (x axis).

Figure 9a is a schematic showing an apparatus with light sources configured to illuminate the sample with light not containing spatial structure and light containing spatial structure.

Figure 9b is a schematic showing the apparatus in Figure 9a with an illumination condition using the light having spatial structure.

Figure 9c is a schematic showing the apparatus in Figure 9a with an illumination condition using the light not having spatial structure.

Figure 10 shows an embodiment of a modulating imaging instrument with structured and unstructured light sources, and an off axis camera.

Figure 11 is a graph showing an example of the relative efficiency of typical LEDs.

Figure 12 are graphs showing (top) a comparison of Full and Efficient methods for recovery of absorption optical properties, and (bottom) a comparison, in percent deviation from the "gold standard" full analysis, shows generally less than 1% difference in accuracy between the approaches, thus validating the Efficient method.

[0016] It should be noted that the figures are not necessarily drawn to scale and that elements of similar structures or functions are generally represented by like reference numerals for illustrative purposes throughout the figures. It also should be noted that the figures are only intended to facilitate the description of the various embodiments described herein. The figures do not necessarily describe every aspect of the teachings disclosed herein and do not limit the scope of the claims.

DESCRIPTION

[0017] The embodiments provided herein are directed to systems and methods that facilitate efficient modulated imaging for quantitative characterization of tissue structure and function. In conventional systems, the same spatially structured light pattern (or patterns) was (were) illuminated at all relevant wavelengths. In one embodiment, an apparatus for increased efficiency modulated imaging system separates the light sources into spatially structured illumination and spatially un-modulated light (planar) illumination. Here planar light is defined as light with substantially no spatial intensity pattern or structure and structured light is defined as light illumination with spatial intensity pattern or structure. The wavelengths of the planar and structured light illuminations are chosen to optimize sensitivity as described below. Systems and methods for efficient modulated imaging are described in U.S. Provisional Application Nos. 61/793,331 and 61/723,721, which applications are incorporated by reference.

[0018] Figure 3(a) shows a preferred embodiment of an increased efficiency modulated imaging apparatus 10. The apparatus 10 comprises an illumination source 12 having a number of external non-structured (planar) light sources 14 on its perimeter and configured to illuminate an area of a tissue sample, a projection system 16 that provides patterned (structured) light to illuminate the area of the tissue sample, and a detector or camera 18 positioned off center from both the projection system 16 and the external planar light source 12 and configured to collect light from the area of the tissue sample illumi-

nated by the projection system 16 and the external planar light source 12. The planar light source 12, projection system 16 and camera 18 are coupled to a printed circuit board (PCB) 22, which includes a processor, power, drivers, memory and software executable on the processor and stored in memory. The light data collected by the camera 18 can be processed using the stored software and processor or ported out to a computer or other processor for processing. The projection system 16, camera 18 and PCB 22 are mounted to an imaging base 20 having a heat sink 21. Two position filters 23 are coupled to the camera 18 and projection system 16.

[0019] The external planar light source 12 is shown in Figure 3(a) as a ring light assembly but could be other externally mounted light sources, including LEDs or lasers, that provide non-spatially structured illumination that does not go through the projection system 16. The ring light assembly includes a plurality of planar light sources 14 positioned about the periphery of a ring base 13. The base 13 along with a cover 11 are externally mounted to a cover 15 of the modulated imaging apparatus 10.

[0020] The selection of wavelengths is flexible in both the projection system 16 and planar, non-structured source(s) 12, 14. The projection system 16, which may include a DLP projector, a LOCOS projector, and the like, may comprise a number of switchable light sources such as Light Emitting Diodes (LEDs) of various wavelengths, such as, e.g., the LEDs 17 and 17' shown in Figure 4 with regard to the planar light source 12, and is capable of providing modulated light of various spatial frequencies or other structured light patterns. The light sources 14 on the external planar illuminator 12 may also be LEDs with one or more wavelengths but specifically provide uniform illumination without spatial structure. The structured projection 16 and external planar light sources 12 are directed to generally the same area on the tissue sample. The camera 18 is off center from both beam axes of the planar light and structured light beam paths and collects light from generally the same area on the tissue sample that has been illuminated. A major benefit of the configuration of the external planar illumination source 12 is increased transfer of non-structured light to the sample due to the relaxed, "non-imaging" constraints which do not require the light to be patterned and optically relayed onto the samples. This configuration improves system efficiency, reduces imaging times to obtain a desired signal-to-noise ratio (SNR), and increases feasibility for applications when measurement times are constrained by practical considerations such as usability and portability.

[0021] In a preferred embodiment, the camera 18 is placed behind and off-axis from the external planar source 12, permitting minimal cross-talk from light scattering directly from the source 12 to camera 18. In a preferred embodiment, the camera 18 is a 12-bit monochrome CCD camera but may include any commercial CMOS camera.

[0022] In Figure 3(b) an example shows a configuration where light is imaged through the middle of a collection of sources, oriented in a ring. Other embodiments are possible, but all have the feature that the structured light and planar light sources 16 and 12 are illuminating generally the same area on the tissue sample and that the camera 18 is configured to image generally the same area illuminated by the structured and planar light sources 16 and 12.

[0023] In another embodiment, as shown in Figure 4, each light source 14 on the planar source 12 has 9 positions that can be populated with any wavelength, which allows the flexible extension of modulated imaging analysis to biological metrics that are sensitive to other wavelengths, see, e.g., a multiple color LED module 17 and a single color LED module 17', which may be complementary to the wavelengths used to perform the core modulated imaging (structured light) measurement. Although shown as 9 positions, each light source 14 on the planar light source 12 can have 9 positions, 12 positions, etc.

[0024] In another embodiment, as shown in Figure 5, the base 13 of the external planar illuminator 12 provides sockets 24 into which the external light sources 14, such as LED modules 17, can be plugged into or taken out of allowing for a reconfigurable wavelength selection.

[0025] In another embodiment, as shown in Figure 4, each light source 14, e.g. an LED module 17, incorporates a beam homogenizer 26, such as an integrating rod or diffuser, to spatially flatten and combine the output from the multiple individually addressable LED chips on the same source.

[0026] *Method of operation and Analysis:* The apparatus 10 for modulated imaging is operated as follows. Modulated imaging typically collects data at a number of discrete wavelengths $\lambda_1, \lambda_2, \dots, \lambda_n$, each of which has a different throughput or signal to noise ratio (SNR) at the camera or detector. The efficient apparatus 10 provided herein separates these n wavelengths into two categories: 1) spatially-structured wavelengths,

$\lambda_1^S, \lambda_2^S, \dots, \lambda_j^S$ and non-structured planar wavelengths

$\lambda_1^P, \lambda_2^P, \dots, \lambda_k^P$. As described above, the motion artifacts tend to appear for wavelengths for which throughput or signal to noise ratio (SNR) is low. The low SNR may result from a low source power, poor projector-source coupling, reduced projector throughput, low received signal or poor detector sensitivity for that wavelength. A low SNR wavelength requires a correspondingly higher integration, (i.e. camera exposure time), making it susceptible to motion. In a demonstration example of the method provided herein, spatially structured illumination was performed with high SNR wavelengths and non-structured planar illumination was performed with low SNR wavelengths. The efficient apparatus 10 provided herein treats the spatially structured and non-structured light differently in the analysis shown in Figure 6 and described in the

following steps as shown in Figures 9b and 9c. As shown schematically in Figure 9a, the efficient apparatus 10 is shown to include a planar light source 12, a structured light source 16 and a camera 18 positioned above a tissue or turbid sample 30.

1) As shown in Figure 9b, the structured light sources 16 are turned on and scanned on the tissue sample 30 at one or a small number of high SNR wave-

lengths (e.g. $\lambda_j^S = \lambda_1^S, \lambda_2^S, \lambda_3^S$), as described briefly in US patent 6958815. The structured light illuminates the sample 30 at these wavelengths with a number of spatial frequencies, and the light reflected and scattered from the sample 30 is collected by the camera 18. This data can then be analyzed to obtain the modulation transfer function and/or optical property information of the sample, for example the spatially-resolved absorption and reduced scattering

$(\mu_a(\lambda_j^S))$ and $\mu_s'(\lambda_j^S)$ maps, using either a physical model for scattering of light in biological tissue, or empirical data-lookup based on a catalog of measurements or simulations. Examples of physical models which account for sample turbidity are the Standard Diffusion Equation and Radiative Transport models of light transport.

2) Next, the measurements at spatially structured wavelengths λ_j^S can be interpolated or extrapolated

to non-structured wavelengths, λ_k^P , based on the wavelength-dependent features of optical properties in the sample of interest. For example, in the near-infrared region, the derived scattering coefficient

$\mu_s'(\lambda_j^S)$ can be fit to a power law function of wavelength such as $\mu_s'(\lambda) = A*\lambda^{-b}$, or more generally $\mu_s'(\lambda) = A_1*\lambda^{-b_1} + A_2*\lambda^{-b_2} + \dots + A_n*\lambda^{-b_n}$, interpolated or extrapolated at each pixel in the image detected by the camera 18 to provide an estimated value for the scattering coefficient for the non-structured

wavelengths, $\mu_s'(\lambda_k^P)$. For the stated equations A and b parameters are free, non-negative variables, and n is at least 1. Note that by deriving property such as the scattering coefficient for a non-structured (ie. low SNR) wavelength from the structured (high SNR) wavelength data, imaging time can be reduced by eliminating the need to acquire structured light

images to directly measure $\mu_s'(\lambda_k^P)$. This permits use of a single non-structured light pattern to deter-

mine the remaining parameter, $\mu_a(\lambda_k^P)$, hence reducing overall acquisition time and avoiding motion artifacts.

3) As shown in Figure 9c, the structured light sources 16, which are at high SNR wavelengths, are then turned off, and the planar light sources 12, which are low SNR wavelengths, are then turned on and used to illuminate the sample 30. The light reflected from the sample 30 is detected by the camera system 18, providing remitted light at the desired wavelengths,

such as the diffuse reflectance coefficients, $R_d(\lambda_k^P)$. As an illustrative example, the diffuse reflectance is measured at 970 nm to determine ctH₂O sensitivity. Note that this Step can alternatively be performed before Step 1, or interleaved with measurements within Step 1.

4) In the last step of the analysis the optical properties at the low SNR wavelengths, λ_k^P are calculated by using the combination of planar and extrapolated or interpolated structured light source measurements.

For example, diffuse reflectivity values ($R_d(\lambda_k^P)$) and the fitted scattering coefficients ($\mu_s'(\lambda) = A*\lambda^{-b}$) evaluated at λ_k^P ; i.e. $\mu_s'(\lambda_k^P) = A*(\lambda_k^P)^{-b}$ can be combined with a 1-parameter fit or lookup-table calculation using a physical scattering/reflection

model for biological tissue, hence yielding $\mu_a(\lambda_k^P)$.

5) At this stage the optical property (e.g. scattering and absorption) coefficients are fully determined for all wavelengths measured directly from the modulation transfer function for data derived from structured illumination wavelengths (i.e. high SNR) and light data derived from non-structured planar illumination wavelengths (i.e. low SNR).

6) Chromophore concentrations and physiology indices can now be derived from the full wavelength dependent scattering and absorption coefficients.

[0027] Note that Steps 2, 4 and/or 6 can be performed at any stage post-measurement of the underlying data. Moreover, instead of being performed sequentially, Steps 2, 4 and/or 6 can be performed together in a direct "global" fit, or simultaneous analysis of all the input data to provide the desired output, such as to obtain the concentration of absorbing or fluorescent molecules.

[0028] Figure 7 shows an example comparison between 1) a full modulated imaging analysis as obtained by the system prescribed by prior art (full fit lines), and 2) the present efficient apparatus and method with reduced number of wavelengths (reduced data lines). There is excellent agreement between the two apparatus and methods. Note, however, that the advantage of the present efficient apparatus is in removal of motion artifacts while providing good fidelity in the optical property (e.g. scattering and absorption) coefficients at all wavelengths.

[0029] To assess the scope of measurements and pa-

tient populations that could be addressed with this refined method, 10 port-wine stain and 10 burn patient measurements were collected and analyzed with a prior art apparatus and method as well as the efficient modulated imaging apparatus 10 and method presented here. Figure 8 shows plots of scattering (Fig. 8a) and absorption coefficients (Fig. 8b) for various wavelengths obtained by the present efficient apparatus (y axis) versus that obtained from the prior art apparatus (x axis). These data are diverse in terms of their absorption coefficients: blood pooling in PWS cases and tissue blanching/loss of epidermal melanin in burn cases exhibit high- and low-absorption, respectively. Nevertheless, Figure 8 shows a one-to-one correspondence of the two as indicated by a straight line with slope = 1.

[0030] In the present description the term camera refers to an optical detection system which images an area of a tissue sample onto an array of pixilated detectors, where the area of the sample imaged is much larger than the smallest spatial feature of the structured light illumination. In another embodiment the light reflected from the sample is collected by a single detector, such that light is collected from an area of the sample which is smaller than the smallest spatial feature of the structured light illuminating it from the projection system.

[0031] Recently, an MI system embodiment implemented both LED flood (unstructured) illumination on the front of the instrument, as well as standard MI LED-based structured projection from a Digital Micromirror Device.

[0032] Figure 10 shows an embodiment of an MI device 110 with structured 116 and unstructured light 112 sources. A camera 118 is configured to view both structured and unstructured light reflecting off of a target positioned approximately one foot (1') in front of the instrument.

[0033] Figure 11 shows an example of the relative efficiency of typical LEDs. Weak wavelengths (low peak values) result in poor imaging speed when required to emit through the projector. These are optimal candidates for flood (unstructured) illumination, avoiding the need to use a low-light-throughput (low etendue) projector.

[0034] Figure 12 (top) shows a comparison of Full and Efficient methods for recovery of absorption optical properties. A measurement of a standardized tissue-simulating phantom with known optical properties was used as an imaging target. For the Full analysis, standard spatial frequency domain measurements were performed. For the Efficient analysis, a subset of the Full analysis was performed for 3 wavelengths (620, 690, 810nm), and then optical scattering values were extrapolated or interpolated to the other desired wavelengths (660, 730, 850, 970nm) to obtain the absorption coefficient with unstructured (planar) data only. This was repeated "in reverse" with structured (660, 730, 850nm) and unstructured (620, 690, 810nm) wavelengths. Bottom: A comparison, in percent deviation from the "gold standard" full analysis, shows generally less than 1% difference in accuracy between the approaches, thus validating the Efficient meth-

od.

[0035] While the invention is susceptible to various modifications, and alternative forms, specific examples thereof have been shown in the drawings and are herein described in detail. It should be understood, however, that the invention is not to be limited to the particular forms or methods disclosed, but to the contrary, the invention is to cover all modifications, equivalents and alternatives falling within the scope of the appended claims.

[0036] In the description above, for purposes of explanation only, specific nomenclature is set forth to provide a thorough understanding of the present disclosure. However, it will be apparent to one skilled in the art that these specific details are not required to practice the teachings of the present disclosure.

[0037] The various features of the representative examples and the dependent claims may be combined in ways that are not specifically and explicitly enumerated in order to provide additional useful embodiments of the present teachings. It is also expressly noted that all value ranges or indications of groups of entities disclose every possible intermediate value or intermediate entity for the purpose of original disclosure, as well as for the purpose of restricting the claimed subject matter.

[0038] It is understood that the embodiments described herein are for the purpose of elucidation and should not be considered limiting the subject matter of the disclosure. Various modifications, uses, substitutions, combinations, improvements, methods of productions without departing from the scope of the present invention would be evident to a person skilled in the art. For example, the reader is to understand that the specific ordering and combination of process actions described herein is merely illustrative, unless otherwise stated, and the invention can be performed using different or additional process actions, or a different combination or ordering of process actions. As another example, each feature of one embodiment can be mixed and matched with other features shown in other embodiments. Features and processes known to those of ordinary skill may similarly be incorporated as desired. Additionally and obviously, features may be added or subtracted as desired. Accordingly, the invention is not to be restricted except in light of the attached claims and their equivalents.

Claims

1. An apparatus for the measurement of a turbid sample comprising:

an illumination apparatus (12, 112) having a plurality of light sources (14) configured to illuminate a target area of a turbid sample with planar non-structured light at a plurality of wavelengths, a projection system (16, 116) configured to illuminate said target area of turbid sample with

spatially structured light at a plurality of wavelengths, wherein the illumination apparatus and the projection system have different optical projection paths, a sensor (18) configured to collect a plurality of wavelengths of planar non-structured light and a plurality of wavelengths of spatially structured light remitted from the target area of the turbid sample, and a processor (22) configured to analyze data of the remitted planar non-structured light and the remitted spatially structured light collected by the sensor to determine the scattering and absorption coefficients of the turbid sample.

- 2.** An apparatus as in Claim 1, wherein the plurality of light sources configured to illuminate the target area of the turbid sample with planar non-structured light are arranged on the perimeter of the illumination apparatus.
- 3.** An apparatus as in Claim 1, wherein the illumination apparatus comprises a light ring assembly.
- 4.** An apparatus as in Claim 3, wherein the light ring assembly includes a ring body with sockets (24) formed about the perimeter of the ring body, wherein the light sources are removably mounted within the sockets
- 5.** An apparatus as in Claim 4, wherein the light sources comprise LED modules.
- 6.** An apparatus as in Claim 1, wherein the sensor is a camera.
- 7.** An apparatus as in Claim 1, wherein the sensor is positioned off axis to the illumination apparatus and the projection system.
- 8.** An apparatus as in Claim 1, wherein the light sources include a beam homogenizer (26).
- 9.** An apparatus as in Claim 8, wherein the beam homogenizer is an integrating rod.
- 10.** An apparatus as in Claim 1, wherein the projection system comprises a number of switchable light sources.
- 11.** An apparatus as in Claim 10, wherein the switchable light sources include LEDs having different wavelengths.
- 12.** An apparatus as in Claims 1 through 11, wherein the wavelengths of the planar non-structured light are different from the wavelengths of the spatially struc-

tured light.

13. An apparatus as in Claim 1, wherein the collected light comprises planar light from the target area and structured light from the target area. 5
14. An apparatus as in Claim 1, wherein the wavelength of the collected planar non-structured light differs from the wavelength of the collected spatially structured light. 10
15. A method for the measurement of a turbid sample comprising the steps of illuminating a turbid sample with spatially structured light, collecting light reflected from the turbid sample to obtain remitted spatially structured light of the turbid sample at a plurality of wavelengths, λ_j , illuminating the turbid sample with planar non-structured light, collecting light reflected from the turbid sample to obtain remitted planar non-structured light of the sample at a plurality of wavelengths, λ_k , and combining measurements of the remitted spatially structured light and the remitted planar non-structured light collected from the turbid sample and determining the scattering and absorption coefficients of the turbid sample wherein determining the scattering and absorption coefficients includes determining fit parameters of the turbid sample, wherein the fit parameters include one or more of the optical properties of the turbid sample at a number of wavelengths-and the concentration of absorbing or fluorescent molecules, **characterised in that** the optical projection path for illuminating the turbid sample with spatially structured light is different to the optical projection path for illuminating the turbid sample with planar non-structured light. 25
16. A method as in Claim 15, wherein the wavelengths of the planar non-structured light, λ_k , are different from the wavelengths of the spatially structured light, λ_j . 30
17. A method as in Claim 15, wherein combining the measurements of the remitted spatially structured light and the remitted planar non-structured light collected from the turbid sample is performed using a scattering function with a dependence of scattering on wavelength to interpolate or extrapolate measurements at discrete wavelengths λ_j of remitted spatially structured light collected from the turbid sample to obtain estimates for scattering at wavelengths λ_k of remitted non-structured light collected from the turbid sample. 40

Patentansprüche

1. Vorrichtung zur Messung einer trüben Probe, umfassend:

eine Beleuchtungsvorrichtung (12, 112), die eine Vielzahl von Lichtquellen (14) aufweist, die ausgelegt ist, um einen Zielbereich einer trüben Probe mit planarem unstrukturierten Licht bei einer Vielzahl von Wellenlängen zu beleuchten, ein Projektionssystem (16, 116), das ausgelegt ist, um den Zielbereich der trüben Probe mit räumlich strukturiertem Licht bei einer Vielzahl von Wellenlängen zu beleuchten, wobei die Beleuchtungsvorrichtung und das Projektionssystem unterschiedliche optische Projektionsstrecken aufweisen, einen Sensor (18), der ausgelegt ist, um eine Vielzahl von Wellenlängen von planarem unstrukturierten Licht und eine Vielzahl von Wellenlängen von räumlich strukturiertem Licht, das von dem Zielbereich der trüben Probe zurückgeschickt wird, zu sammeln, und einen Prozessor (22), der ausgelegt ist, um Daten des zurückgeschickten planaren unstrukturierten Lichts und des zurückgeschickten räumlich strukturierten Lichts, das von dem Sensor gesammelt wurde, zu analysieren, um die Streu- und Absorptionskoeffizienten der trüben Probe zu bestimmen.

2. Vorrichtung nach Anspruch 1, wobei die Vielzahl von Lichtquellen, die ausgelegt ist, um den Zielbereich der trüben Probe mit planarem unstrukturierten Licht zu beleuchten, an dem Umfang der Beleuchtungsvorrichtung angeordnet ist.
3. Vorrichtung nach Anspruch 1, wobei die Beleuchtungsvorrichtung eine Lichtringanordnung umfasst.
4. Vorrichtung nach Anspruch 3, wobei die Lichtringanordnung einen Ringkörper mit Fassungen (24) beinhaltet, die um den Umfang des Ringkörpers gebildet sind, wobei die Lichtquellen entfernbar innerhalb der Fassungen angebracht sind.
5. Vorrichtung nach Anspruch 4, wobei die Lichtquellen LED-Module umfassen.
6. Vorrichtung nach Anspruch 1, wobei der Sensor eine Kamera ist.
7. Vorrichtung nach Anspruch 1, wobei der Sensor außerhalb der Achse zu der Beleuchtungsvorrichtung und dem Projektionssystem positioniert ist.
8. Vorrichtung nach Anspruch 1, wobei die Lichtquellen einen Strahlhomogenisator (26) beinhalten.
9. Vorrichtung nach Anspruch 8, wobei der Strahlhomogenisator ein Integratorstab ist.
10. Vorrichtung nach Anspruch 1, wobei das Projekti-

- onssystem eine Anzahl von schaltbaren Lichtquellen umfasst.
11. Vorrichtung nach Anspruch 10, wobei die schaltbaren Lichtquellen LEDs beinhalten, die unterschiedliche Wellenlängen aufweisen. 5
12. Vorrichtung nach Anspruch 1 bis 11, wobei sich die Wellenlängen des planaren unstrukturierten Lichts von den Wellenlängen des räumlich strukturierten Lichts unterscheiden. 10
13. Vorrichtung nach Anspruch 1, wobei das gesammelte Licht planares Licht von dem Zielbereich und strukturiertes Licht von dem Zielbereich umfasst. 15
14. Vorrichtung nach Anspruch 1, wobei sich die Wellenlänge des gesammelten planaren unstrukturierten Lichts von der Wellenlänge des gesammelten räumlich strukturierten Lichts unterscheidet. 20
15. Verfahren zur Messung einer trüben Probe, umfassend die Schritte des
 Beleuchtens einer trüben Probe mit räumlich strukturiertem Licht, 25
 Sammelns von Licht, das von der trüben Probe reflektiert wird, um zurückgeschicktes räumlich strukturiertes Licht der trüben Probe bei einer Vielzahl von Wellenlängen, λ_j , zu erhalten, Beleuchtens der trüben Probe mit planarem unstrukturierten Licht, 30
 Sammelns von Licht, das von der trüben Probe reflektiert wird, um zurückgeschicktes planares unstrukturiertes Licht der Probe bei einer Vielzahl von Wellenlängen, λ_k , zu erhalten, und Kombinierens von Messungen des zurückgeschickten räumlich strukturierten Lichts und des zurückgeschickten planaren unstrukturierten Lichts, das von der trüben Probe gesammelt wurde, und Bestimmens der Streu- und Absorptionskoeffizienten der trüben Probe, wobei das Bestimmen der Streu- und Absorptionskoeffizienten das Bestimmen von geeigneten Parametern der trüben Probe beinhaltet, wobei die geeigneten Parameter eine oder mehrere der optischen Eigenschaften der trüben Probe bei einer Anzahl von Wellenlängen und die Konzentration von absorbierenden oder fluoreszierenden Molekülen beinhalten, **dadurch gekennzeichnet, dass** sich die optische Projektionsstrecke zum Beleuchten der trüben Probe mit räumlich strukturiertem Licht von der optischen Projektionsstrecke zum Beleuchten der trüben Probe mit planarem unstrukturierten Licht unterscheidet. 40
 45
 50
16. Verfahren nach Anspruch 15, wobei sich die Wellenlängen des planaren unstrukturierten Lichts, λ_k , von den Wellenlängen des räumlich strukturierten Lichts, λ_j , unterscheiden. 55

17. Verfahren nach Anspruch 15, wobei das Kombinieren der Messungen des zurückgeschickten räumlich strukturierten Lichts und des zurückgeschickten planaren unstrukturierten Lichts, das von der trüben Probe gesammelt wurde, unter Verwendung einer Streufunktion mit einer Abhängigkeit der Streuung von der Wellenlänge durchgeführt wird, um Messungen bei einzelnen Wellenlängen λ_j von zurückgeschicktem räumlich strukturiertem Licht, das von der trüben Probe gesammelt wurde, zu interpolieren oder zu extrapolieren, um Schätzungen für die Streuung bei Wellenlängen λ_k von zurückgeschicktem unstrukturiertem Licht, das von der trüben Probe gesammelt wurde, zu erhalten.

Revendications

1. Appareil de mesure d'un échantillon trouble comprenant :
- un appareil d'éclairage (12, 112) ayant une pluralité de sources de lumière (14) conçues pour éclairer une zone cible d'un échantillon trouble avec une lumière non structurée plane à une pluralité de longueurs d'onde,
 un système de projection (16, 116) conçu pour éclairer ladite zone cible de l'échantillon trouble avec une lumière structurée spatialement à une pluralité de longueurs d'onde,
 dans lequel l'appareil d'éclairage et le système de projection ont des trajets de projection optique différents,
 un capteur (18) conçu pour collecter une pluralité de longueurs d'onde de la lumière non structurée plane et une pluralité de longueurs d'onde de la lumière structurée spatialement renvoyées à partir de la zone cible de l'échantillon trouble, et
 un processeur (22) conçu pour analyser des données de la lumière non structurée plane renvoyée et de la lumière structurée spatialement renvoyée collectées par le capteur pour déterminer les coefficients de diffusion et d'absorption de l'échantillon trouble.
2. Appareil selon la revendication 1, dans lequel la pluralité de sources de lumière conçues pour éclairer la zone cible de l'échantillon trouble avec une lumière non structurée plane sont disposées sur le périmètre de l'appareil d'éclairage.
3. Appareil selon la revendication 1, dans lequel l'appareil d'éclairage comprend un ensemble annulaire d'éclairage.
4. Appareil selon la revendication 3, dans lequel l'ensemble annulaire d'éclairage comprend un corps an-

- nulaire avec des douilles (24) formées autour du périmètre du corps annulaire, dans lequel les sources de lumière sont montées de manière amovible à l'intérieur des douilles.
5. Appareil selon la revendication 4, dans lequel les sources de lumière comprennent des modules à DEL. 5
6. Appareil selon la revendication 1, dans lequel le capteur est une caméra. 10
7. Appareil selon la revendication 1, dans lequel le capteur est positionné hors axe par rapport à l'appareil d'éclairage et au système de projection. 15
8. Appareil selon la revendication 1, dans lequel les sources de lumière comprennent un homogénéisateur de faisceau (26). 20
9. Appareil selon la revendication 8, dans lequel l'homogénéisateur de faisceau est une tige d'intégration.
10. Appareil selon la revendication 1, dans lequel le système de projection comprend un certain nombre de sources de lumière commutables. 25
11. Appareil selon la revendication 10, dans lequel les sources de lumière commutables comprennent des DEL ayant des longueurs d'onde différentes. 30
12. Appareil selon les revendications 1 à 11, dans lequel les longueurs d'onde de la lumière non structurée plane sont différentes des longueurs d'onde de la lumière structurée spatialement. 35
13. Appareil selon la revendication 1, dans lequel la lumière collectée comprend une lumière plane provenant de la zone cible et une lumière structurée provenant de la zone cible. 40
14. Appareil selon la revendication 1, dans lequel la longueur d'onde de la lumière non structurée plane collectée est différente de la longueur d'onde de la lumière structurée spatialement collectée. 45
15. Procédé de mesure d'un échantillon trouble comprenant les étapes d'éclairage d'un échantillon trouble avec une lumière structurée spatialement, de collecte de la lumière réfléchie à partir de l'échantillon trouble pour obtenir une lumière structurée spatialement renvoyée de l'échantillon trouble à une pluralité de longueurs d'onde, λ_j , d'éclairage de l'échantillon trouble avec une lumière non structurée plane, de collecte de la lumière réfléchie à partir de l'échan-
- tillon trouble pour obtenir une lumière non structurée plane renvoyée de l'échantillon à une pluralité de longueurs d'onde, λ_k , et de combinaison de mesures de la lumière structurée spatialement renvoyée et de la lumière non structurée plane renvoyée collectées à partir de l'échantillon trouble et de détermination des coefficients de diffusion et d'absorption de l'échantillon trouble dans lequel la détermination des coefficients de diffusion et d'absorption comprend la détermination de paramètres d'ajustement de l'échantillon trouble, dans lequel les paramètres d'ajustement comprennent une ou plusieurs des propriétés optiques de l'échantillon trouble à un certain nombre de longueurs d'onde et la concentration de molécules absorbantes ou fluorescentes, **caractérisé en ce que** le trajet de projection optique pour éclairer l'échantillon trouble avec une lumière structurée spatialement est différent du trajet de projection optique pour éclairer l'échantillon trouble avec une lumière non structurée plane.
16. Procédé selon la revendication 15, dans lequel les longueurs d'onde de la lumière non structurée plane, λ_k , sont différentes des longueurs d'onde de la lumière structurée spatialement, λ_j .
17. Procédé selon la revendication 15, dans lequel la combinaison des mesures de la lumière structurée spatialement renvoyée et de la lumière non structurée plane renvoyée collectées à partir de l'échantillon trouble est réalisée en utilisant une fonction de diffusion avec une dépendance de la diffusion sur la longueur d'onde pour interpoler ou extrapoler des mesures à des longueurs d'onde discrètes λ_j de la lumière structurée spatialement renvoyée collectées à partir de l'échantillon trouble pour obtenir des estimations de la diffusion aux longueurs d'onde λ_k de la lumière non structurée renvoyée collectées à partir de l'échantillon trouble.

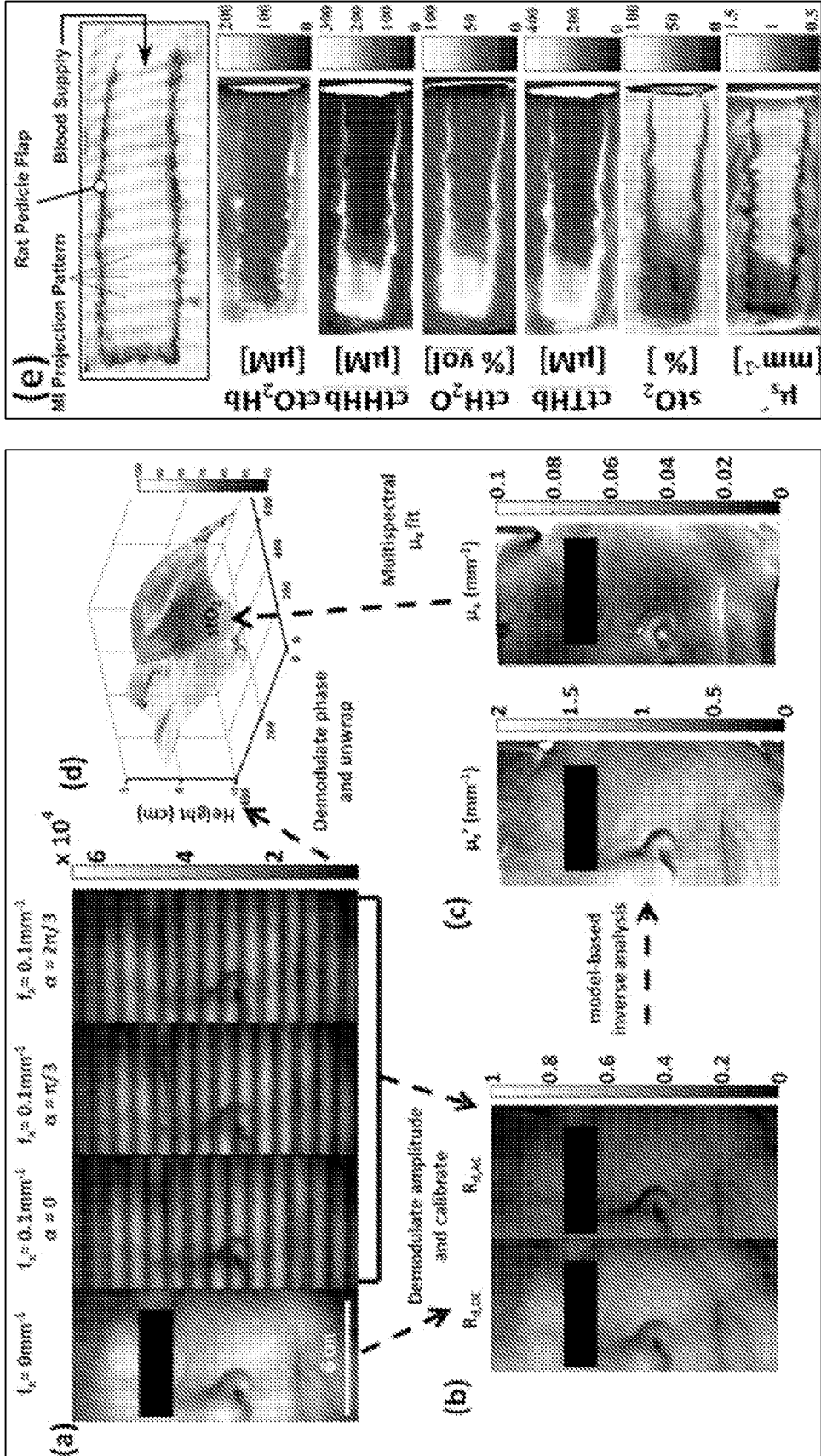

FIG. 1

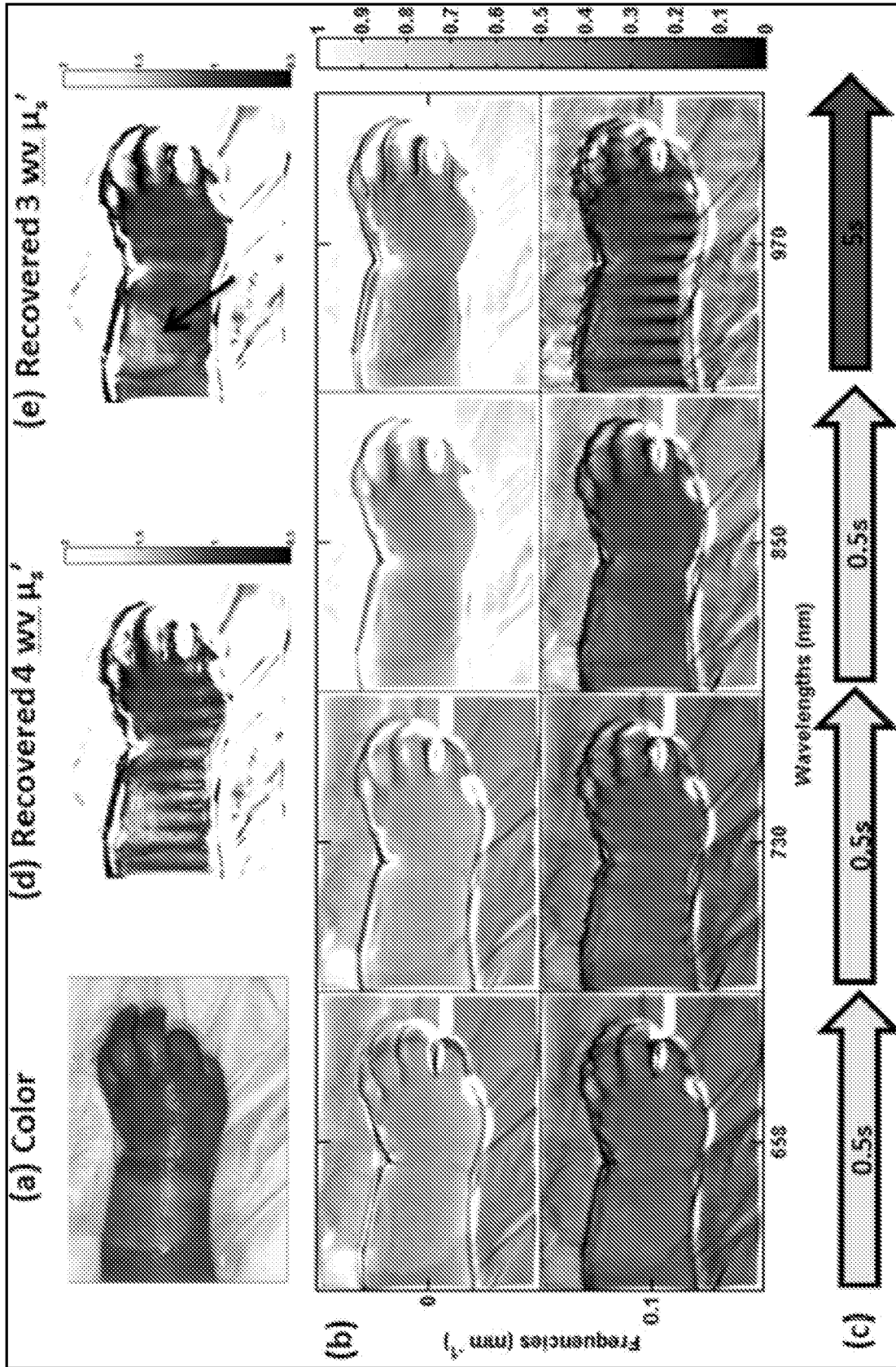

FIG. 2

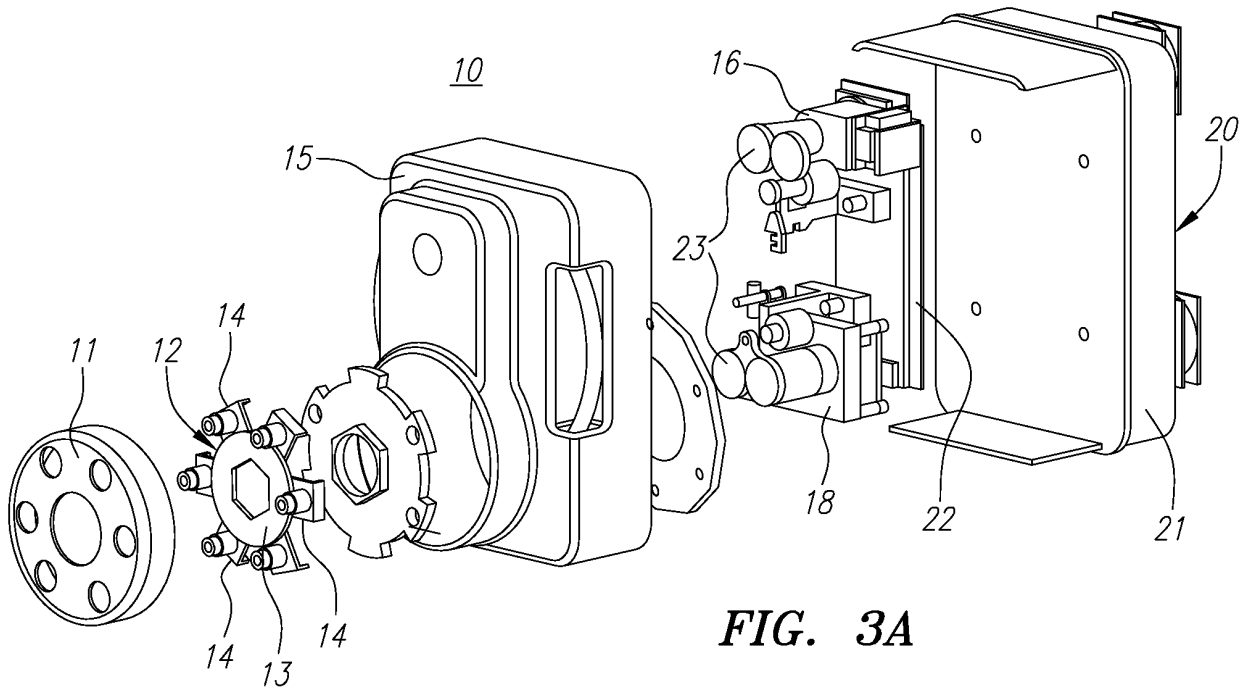

FIG. 3A

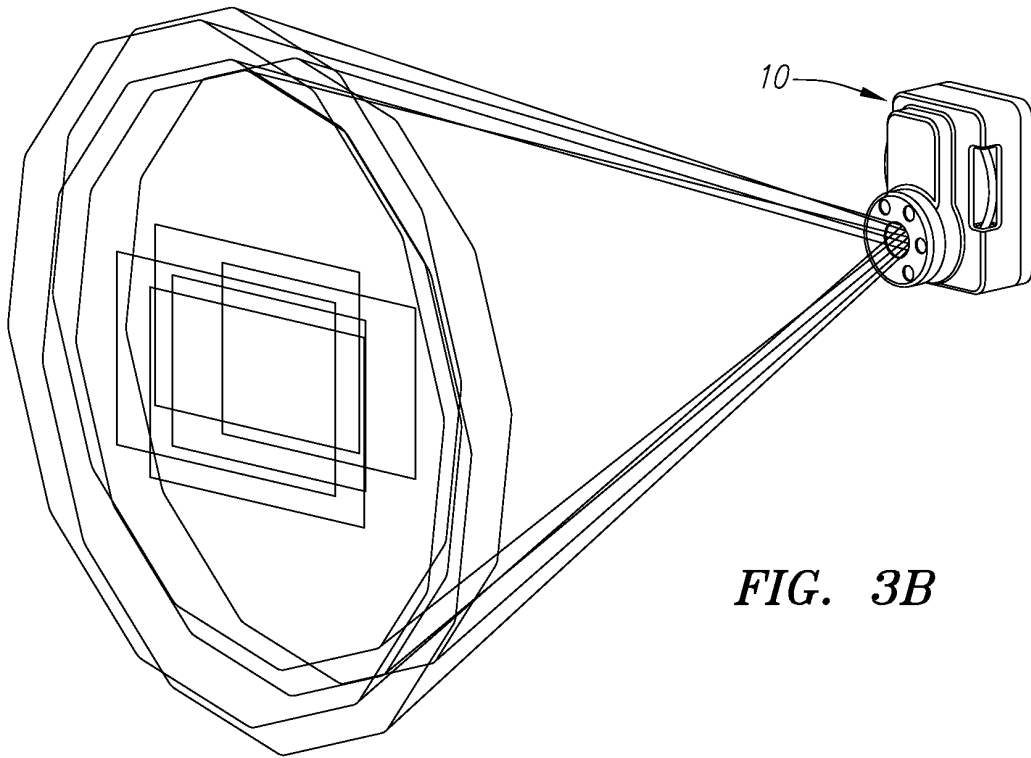

FIG. 3B

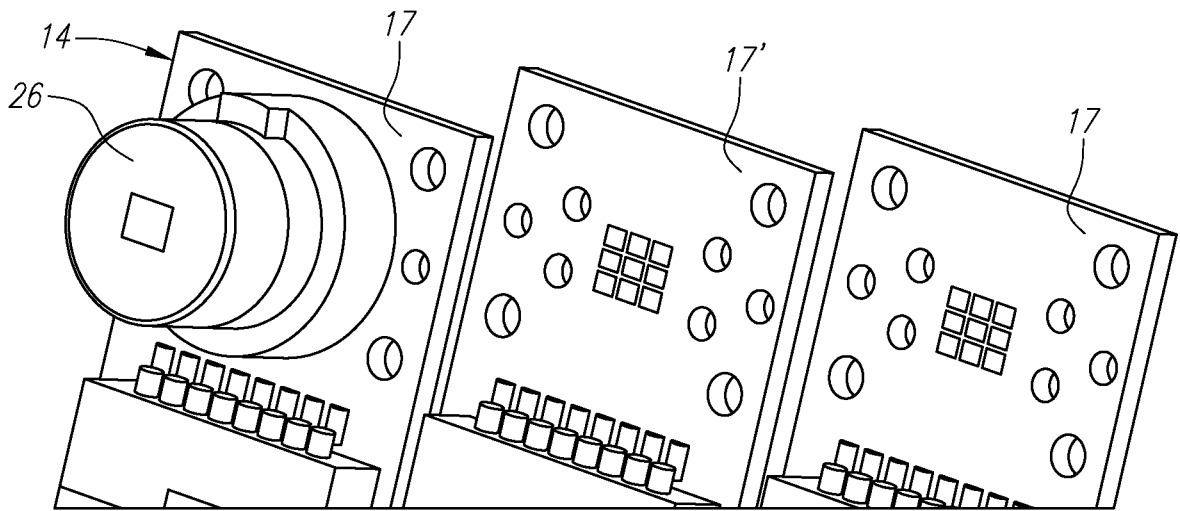

FIG. 4

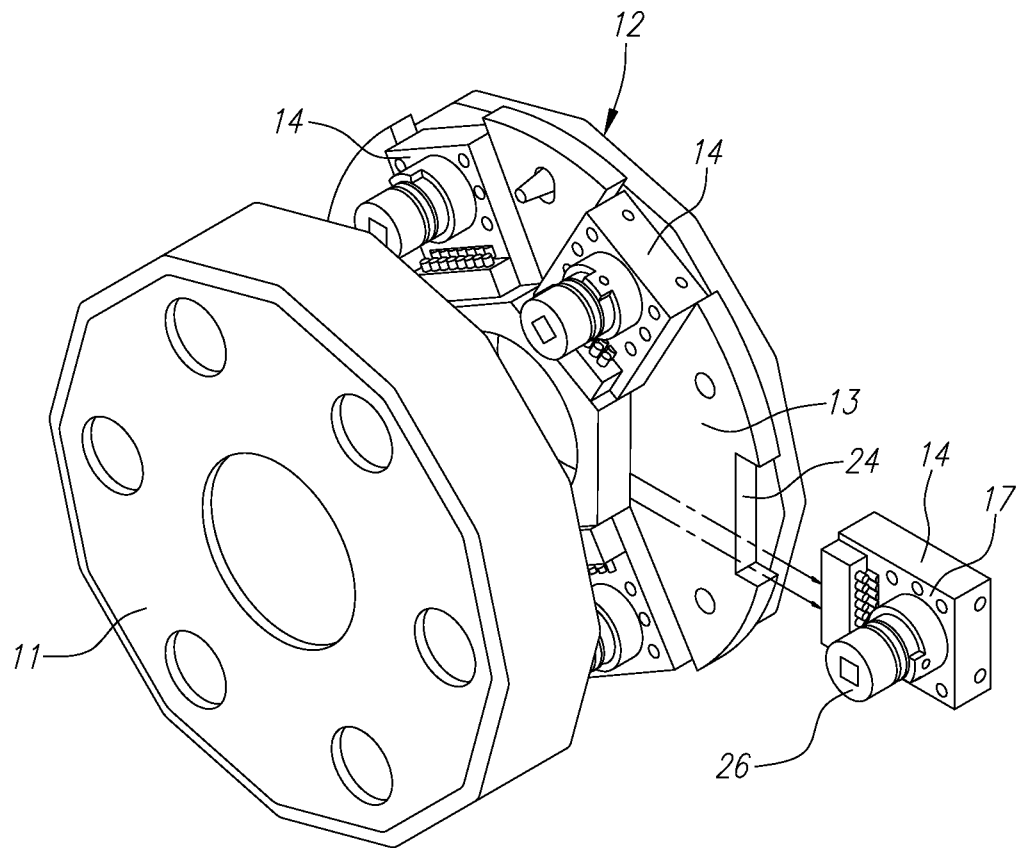

FIG. 5

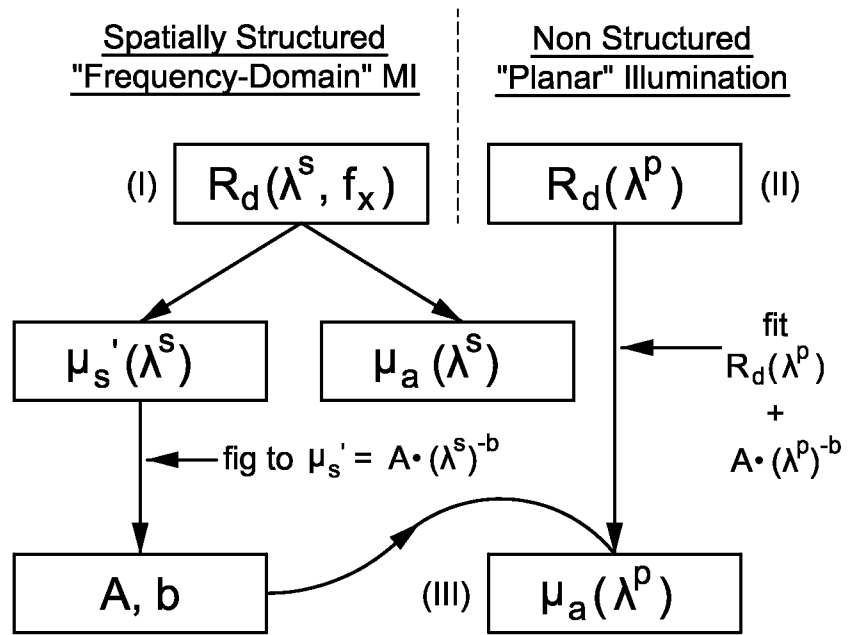

FIG. 6

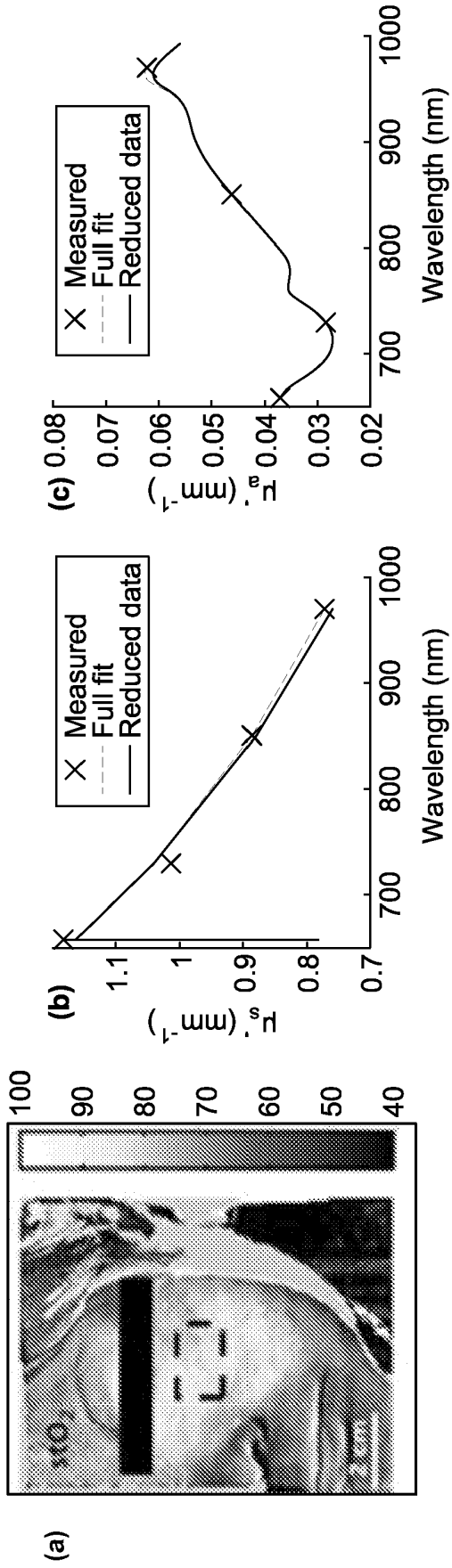

FIG. 7

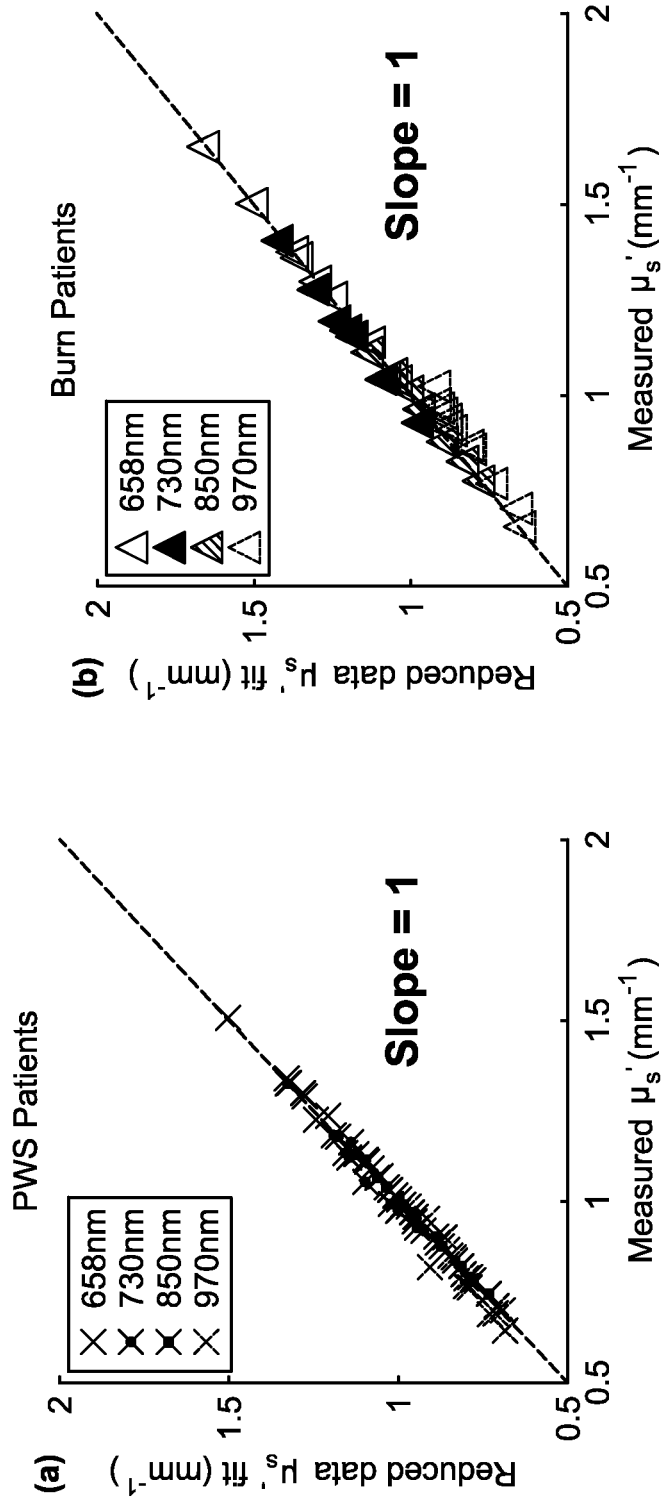

FIG. 8

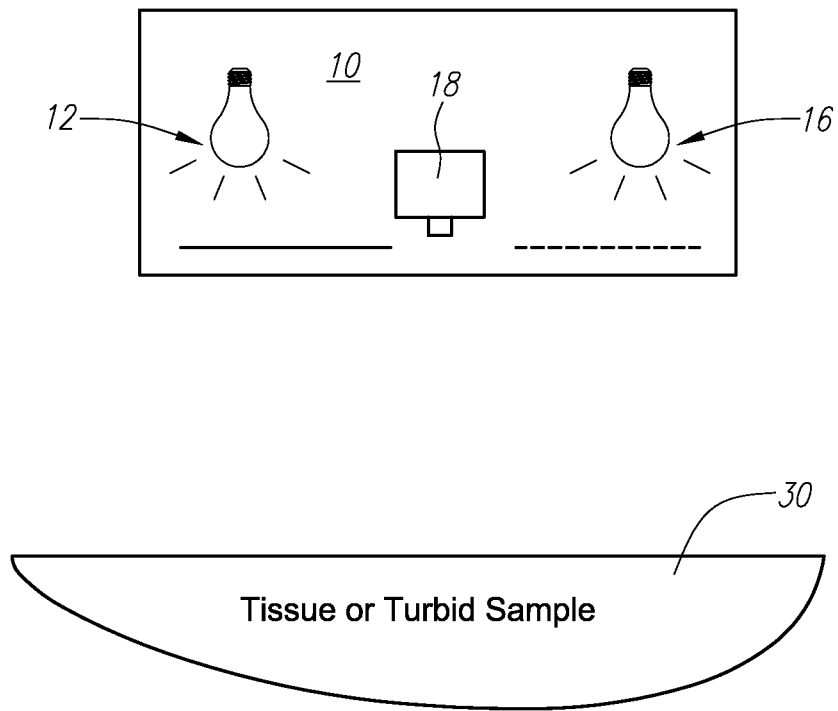

FIG. 9a

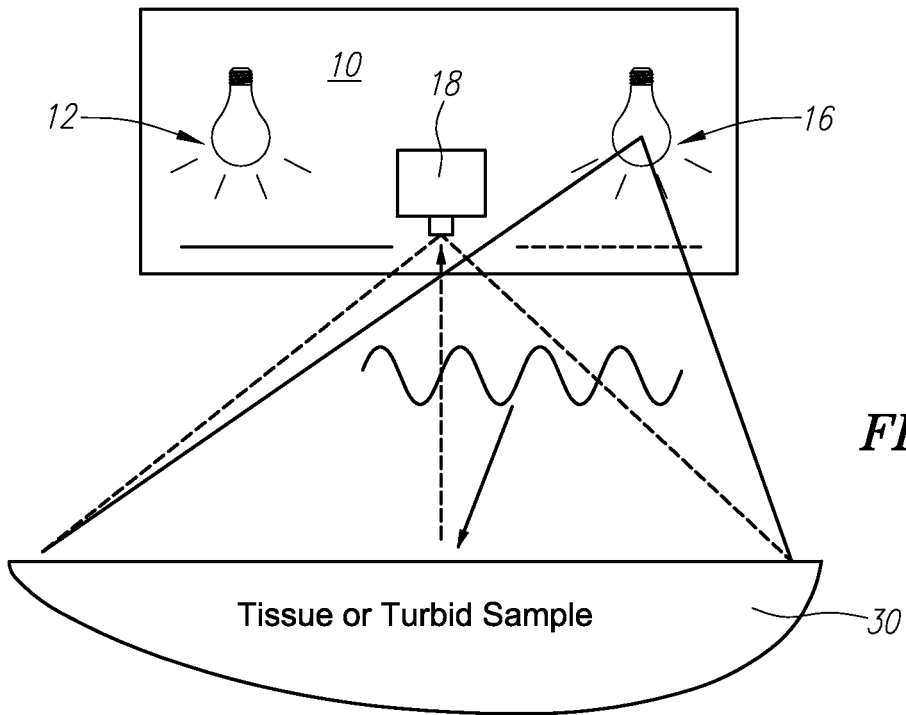

FIG. 9b

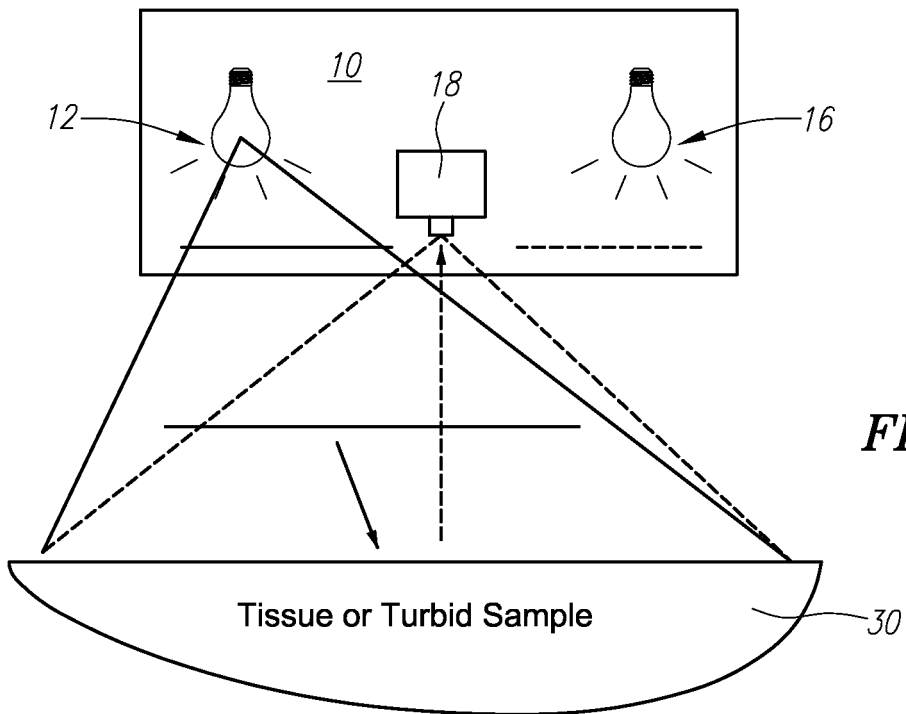

FIG. 9c

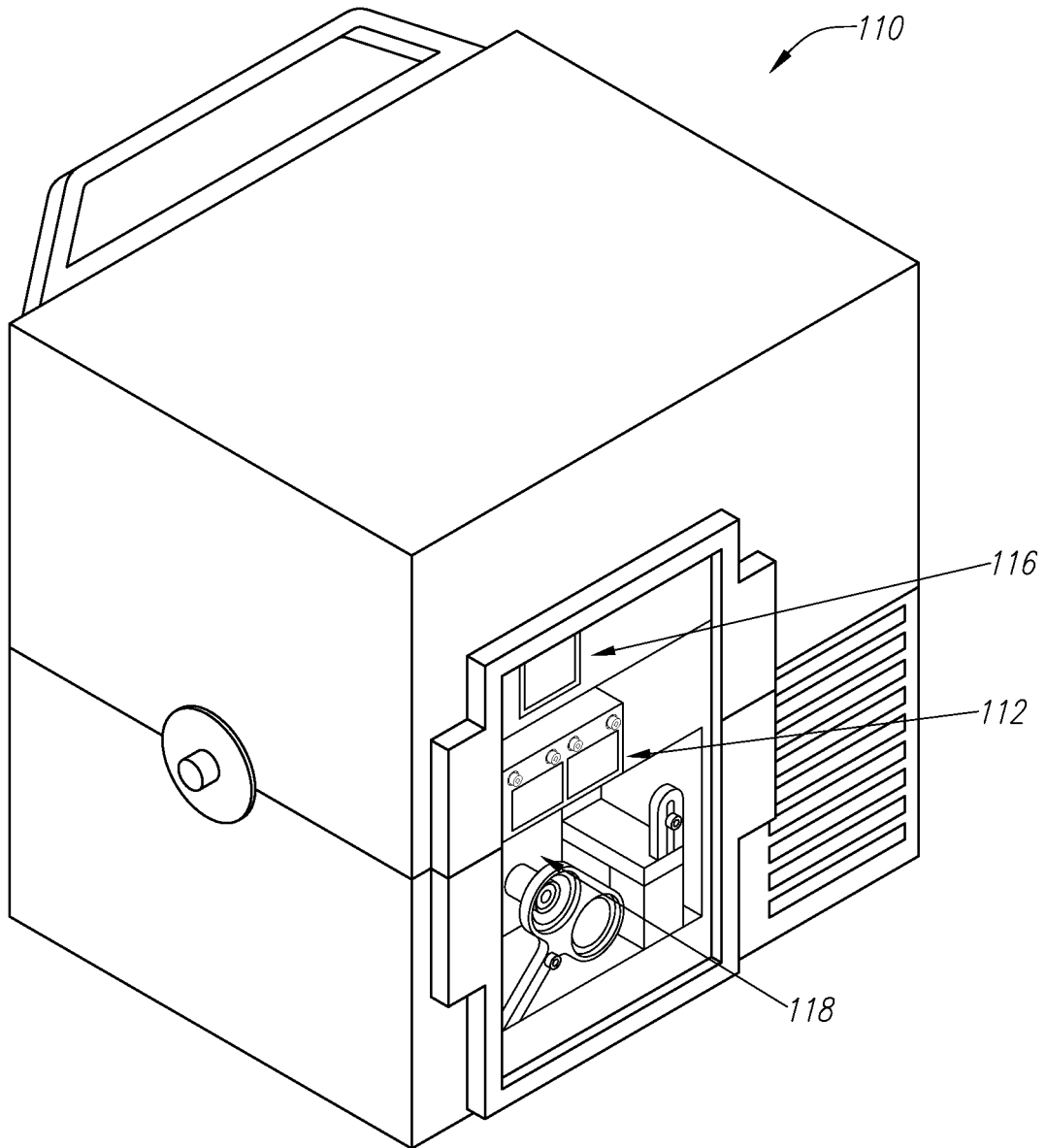

FIG. 10

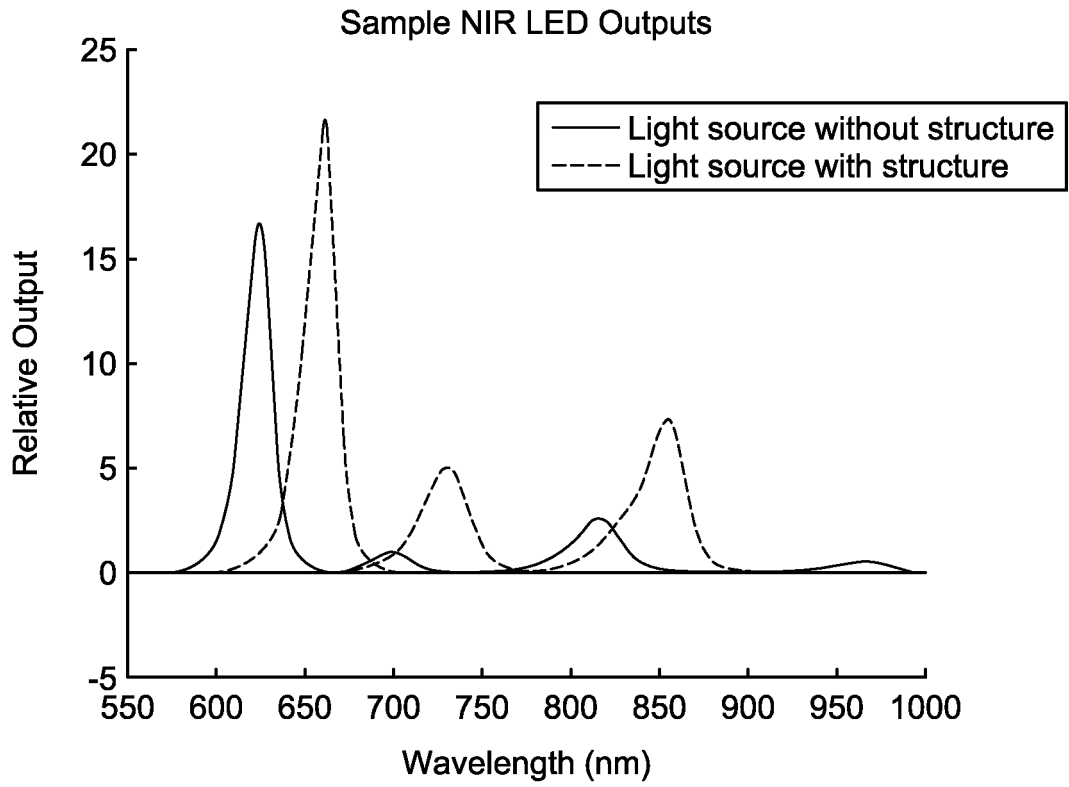
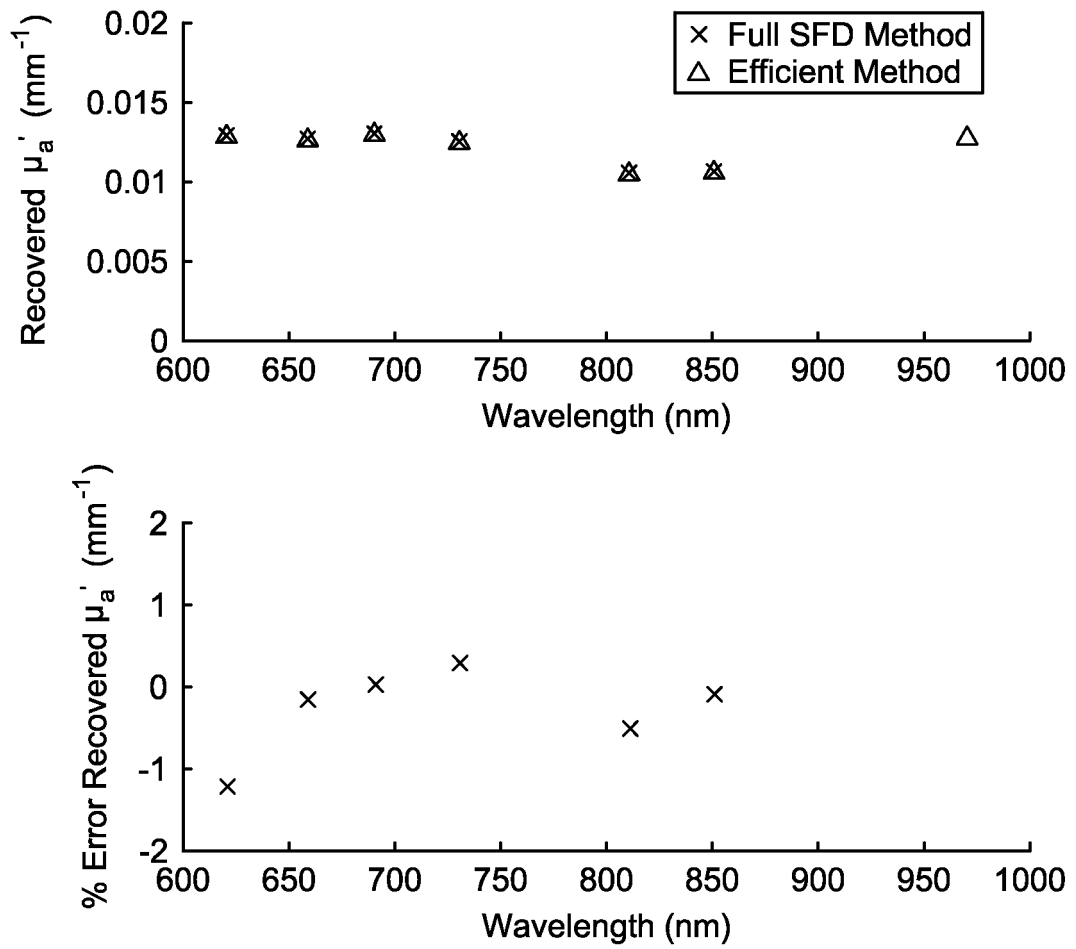

FIG. 11

*FIG. 12*

REFERENCES CITED IN THE DESCRIPTION

This list of references cited by the applicant is for the reader's convenience only. It does not form part of the European patent document. Even though great care has been taken in compiling the references, errors or omissions cannot be excluded and the EPO disclaims all liability in this regard.

Patent documents cited in the description

- US 6958815 B2 [0004]
- US 7418118 B2 [0012]
- US 2006029350 A [0012]
- US 2003023172 A [0012]
- US 20110124988 A [0012]
- US 61793331 A [0017]
- US 61723721 B [0017]
- US 6958815 B [0026]

专利名称(译)	高效的调制成像		
公开(公告)号	EP2898326A1	公开(公告)日	2015-07-29
申请号	EP2013852589	申请日	2013-11-07
申请(专利权)人(译)	调制的IMAGING INC.		
当前申请(专利权)人(译)	调制的IMAGING INC.		
[标]发明人	CUCCIA DAVID MAZHAR AMAAN		
发明人	CUCCIA, DAVID MAZHAR, AMAAN		
IPC分类号	G01N33/48 A61B5/1455 A61B5/00		
CPC分类号	A61B5/0064 A61B5/0077 A61B5/0071		
优先权	61/723721 2012-11-07 US 61/793331 2013-03-15 US		
其他公开文献	EP2898326A4 EP2898326B1		
外部链接	Espacenet		

摘要(译)

一种用于混浊样本测量的装置，包括用于利用非空间结构光照射混浊样本目标区域的多个光源，用于利用空间结构光照射混浊样本目标区域的投影系统，用于从混浊样本收集光的传感器目标区域和处理器，用于分析传感器捕获的数据，以产生混浊样品的散射和吸收系数。一种方法包括用空间结构光照射样品，收集从多个波长的样品反射的光，用非空间结构光照射样品，收集从多个波长的样品反射的光，并组合测量结果。收集的光以获得样品的光学性质和/或吸收或荧光分子的浓度。空间和非空间光源的波长优选是不同的。