

(19)



(11)

EP 2 680 920 B1

(12)

EUROPEAN PATENT SPECIFICATION

(45) Date of publication and mention of the grant of the patent:
09.08.2017 Bulletin 2017/32

(51) Int Cl.:
A61B 8/08 ^(2006.01) **A61B 5/00** ^(2006.01)
A61M 5/142 ^(2006.01) **A61M 25/06** ^(2006.01)
A61M 5/152 ^(2006.01) **A61N 1/05** ^(2006.01)
A61N 1/36 ^(2006.01) **A61M 25/01** ^(2006.01)

(21) Application number: **12786621.8**

(22) Date of filing: **18.05.2012**

(86) International application number:
PCT/US2012/038504

(87) International publication number:
WO 2012/159000 (22.11.2012 Gazette 2012/47)

(54) CONTINUOUS ANESTHESIA NERVE CONDUCTION APPARATUS

KONTINUIERLICHE ANÄSTHESIE-NERVENLEITUNGSVORRICHTUNG

APPAREIL D'ANESTHÉSIE CONTINUE DE LA CONDUCTION NERVEUSE

(84) Designated Contracting States:
AL AT BE BG CH CY CZ DE DK EE ES FI FR GB GR HR HU IE IS IT LI LT LU LV MC MK MT NL NO PL PT RO RS SE SI SK SM TR

(74) Representative: **Hanna Moore + Curley**
Garryard House
25/26 Earlsfort Terrace
Dublin 2, D02 PX51 (IE)

(30) Priority: **18.05.2011 US 201161487555 P**
08.09.2011 US 201161532316 P

(56) References cited:
US-A- 5 158 544 **US-A1- 2001 032 003**
US-A1- 2002 026 209 **US-A1- 2003 093 104**
US-A1- 2004 181 206 **US-A1- 2005 020 965**
US-A1- 2005 043 709 **US-A1- 2005 171 478**
US-A1- 2005 192 638 **US-A1- 2005 257 751**
US-A1- 2005 283 111 **US-A1- 2006 015 068**
US-A1- 2006 217 655 **US-A1- 2007 088 382**
US-A1- 2008 058 702 **US-A1- 2008 228 133**
US-A1- 2010 003 282 **US-A1- 2010 049 171**
US-A1- 2011 034 790 **US-A1- 2011 112 511**

(43) Date of publication of application:
08.01.2014 Bulletin 2014/02

(73) Proprietor: **Solodex LLC**
Colorado Springs, CO 80904 (US)

(72) Inventors:

- **RAJENDRAN, Sundar**
Colorado Springs, CO 80904 (US)
- **KOPACZ, Dan Joel**
Colorado Springs, CO 80906 (US)

EP 2 680 920 B1

Note: Within nine months of the publication of the mention of the grant of the European patent in the European Patent Bulletin, any person may give notice to the European Patent Office of opposition to that patent, in accordance with the Implementing Regulations. Notice of opposition shall not be deemed to have been filed until the opposition fee has been paid. (Art. 99(1) European Patent Convention).

Description**BACKGROUND OF THE INVENTION**5 **Field of the Invention**

[0001] The invention generally relates to a continuous anesthesia nerve conduction apparatus for use in administering a continuous flow or intermittent bolus of anesthetic agent to facilitate a continuous or prolonged nerve block.

10 **Discussion of the Related Art**

[0002] Currently, regional anesthesia techniques have been employed to selectively anesthetize a nerve or groups of nerves to provide pain relief to patients following a medical-surgical procedure or trauma. Anesthetic agents, such as local anesthetic medication, are administered in close proximity to nerve(s) that innervate the affected region of the body. These nerves are located deep within the tissues and a hollow bore hypodermic needle is used to deliver the anesthetic medication to the nerve(s).

[0003] In continuous regional anesthetic procedures, in lieu of a needle, a catheter and needle are inserted adjacent to the nerve(s). The needle is removed after the catheter placement, and the catheter may be left in position for several days so that anesthetic medication can be repeatedly or continuously delivered to the targeted nerve(s). These nerve blocks are only efficacious if the anesthetic medication can be delivered consistently in close enough proximity to the nerve(s) so as to impart its action on the nerve(s).

[0004] U.S. Pat. No. 5,976,110 discloses an epidural needle that can be coupled to a nerve stimulator. The nerve stimulator is configured to provide an electrical current that activates the targeted nerve(s) as the needle gets into close proximity of the nerve(s). An epidural catheter is inserted through the lumen of the epidural needle and advanced until the distal tip extends several centimeters past the distal tip of the needle. The epidural catheter is placed without any visualization aid and is assumed to be in close enough proximity to the targeted nerve due to the needle tip position.

[0005] U.S. Pat. No. 6,456,874 discloses an epidural catheter configured to emit an electrical impulse. Placement of the catheter tip and confirmation of the catheter tip placement is obtained by stimulating the targeted nerve(s) via the nerve stimulator.

[0006] In addition to the use of peripheral nerve stimulation for nerve localization, ultrasound imaging has become a common method to position needles and catheters in close proximity to nerve(s).

[0007] US2010049171 (A1) discloses a drainage catheter for draining part of patient's body. The catheter comprises an elongated member having a proximal portion extending to a distal portion and a lumen formed therethrough for fluid communication with the patient's body. The distal portion is formed of a polymer material having a first phase transition temperature and a second phase transition temperature that is less than the first phase transition temperature but is greater than about body temperature. The distal portion has a first configuration when at about body temperature for at least one of moving and anchoring the distal portion within the patient's body. The distal portion self-configures to a second configuration when at a temperature of at least the second phase transition temperature for retrieval of the distal portion from the patient's body.

[0008] US2005043709 (A1) discloses a catheter and introducer needle assembly including a catheter adapter at its proximal end. The catheter adapter includes a side port in fluid communication with the catheter. A septum is located in the proximal end of the catheter adapter proximal of the side port. The introducer needle is connected at its proximal end to a needle hub and includes at least one notch formed therein in communication with the introducer needle lumen. The notch is formed in the needle such that blood can flow into the open distal end of the needle, through the lumen in the needle and through the notch into the catheter lumen (specifically, the annular space between the outside of the introducer needle and the inside of the catheter and catheter adapter). Thereafter, the blood can flow through the annular space and then through the side port and extension tube that extends from the catheter adapter.

[0009] US2005020965 (A1) discloses an apparatus for delivering a therapeutic or diagnostic agent to a target site within a body which includes an outer tubular body, an inner tubular body slidably disposed within the outer tubular body, a substance delivery port located on the inner tubular body, and an electrode secured to the outer tubular body. The delivery port may be used to deliver a medical substance to the target site, and the electrode can be used to seal an access channel leading to the treatment site, thereby substantially preventing migration of material from the delivery site. In order to minimize the profile of the apparatus, a braided conductor can extend through the wall of the outer tubular body, thereby providing a means for delivering electrical energy to the electrode, while strengthening the wall of the outer tubular body to minimize the risk of rupture during delivery of the substance.

[0010] The related art has a number of disadvantages. The ultrasound probe is best managed by the operator of the needle and/or catheter. As such, to maintain real-time imaging, one of the operator's hands needs to be occupied handling the ultrasound transducer. However, the procedure is difficult with the related art devices as both hands are

required for advancing a catheter through the needle. Therefore, during this procedure the ultrasound probe must be put down and the visualization at that point is lost.

5 [0011] Alternatively, another clinician is required or some sort of mechanical holding means may be utilized. These alternatives both have disadvantages. The ultrasound image is a two-dimensional image with an image plane of typically less than one millimeter. The mechanical holding devices, i.e., an articulating probe holder often is not effective because patient movement can cause the image to distort or deviate, thereby preventing reliable real-time imaging of the catheter exiting the needle and also preventing visual confirmation of the position of the catheter tip. Moreover, the related art catheter devices frequently employ Touhy tipped needles that tend to cause the catheter to curve away from the tip of the needle and out of the two-dimensional visualization plane as the catheter exits the needle. Therefore, images of the 10 needle with the catheter exiting the needle are not typically obtained and the relationship to the targeted nerve(s) is not conclusively obtained.

[0012] Another disadvantage of the related art is the need for two hands to manage the catheter advancement, as both hands require sterile gloves and sterile procedural adherence. Thus, the ultrasound device will need to be sterile, which requires additional setup such as sterile sleeves for the ultrasound probe, sterile ultrasound gel, extensive draping, 15 and additional personnel. This additional setup adds to the complexity, inefficiency, timeliness, and cost of clinicians performing this technique.

[0013] The related art catheters themselves also have disadvantages. For example, in order for the needle to be withdrawn while trying to maintain the catheter in place, the catheter needs to be about twice the length of the needle. This added length makes the catheter unwieldy, expensive, and difficult to use. The catheter also requires a lubricious exterior so that it will easily slide through the needle. The lubricious exterior of the catheter makes it difficult to adhere 20 to the skin of the patient, which leads to easy dislodgement from its position adjacent to the nerve(s).

[0014] In addition, passing the catheter through the lumen of a large bore needle, the catheter's diameter is such that it is smaller than that of the puncture made by the needle through the tissue. The catheter diameter size being smaller than the needle can lead to leakage of medication at the insertion site during medication infusion, increasing the chance 25 of catheter dislodgement.

[0015] There is a need for an improved continuous anesthesia nerve conduction apparatus, system and method that substantially obviates one or more of the problems due to limitations and disadvantages of the related art.

SUMMARY OF THE INVENTION

30 [0016] Accordingly, the invention is directed to continuous anesthesia nerve conduction apparatus that substantially obviates one or more of the problems due to limitations and disadvantages of the related art. The invention is defined by claim 1. Preferred embodiments are defined by the dependent claims. Further embodiments disclosed herein are for exemplary purpose only.

35 [0017] An advantage of the invention is that the procedure may be performed by one proficient in the art in approximately the same time or less than it takes to perform a single-injection nerve block with a needle alone. In most cases, the procedure may be performed in less than about ten minutes.

[0018] Another advantage of the invention is that the procedure does not require a full sterile setup.

40 [0019] Still another advantage of the invention is to provide an apparatus for performing continuous nerve blocks under real-time ultrasound guidance that may be performed with a single hand by one operator.

[0020] Yet another advantage of the invention is to provide an apparatus that allows for easy handling with secure fixation to prevent dislodgement and minimize leakage during infusion.

45 [0021] Still yet another advantage is to provide an apparatus that allows for a single operator to easily and efficiently place a continuous nerve conduction catheter while simultaneously visualizing the catheter placement under ultrasound guidance, e.g., with markings or markers as described herein.

[0022] Yet still another advantage is to provide an apparatus that allows for peripheral nerve stimulation capability to be performed simultaneously with visualization with one handed operation.

50 [0023] Another advantage is to provide peripheral nerve stimulation emitting from a needle and/or the catheter. The catheter stimulation may be used for secondary confirmation, if needed. The nerve stimulation can also be utilized via a single electrical connection at or near a hub of the catheter.

[0024] Still another advantage is to provide an apparatus that permits a fast, cost efficient, and minor labor intensive process, thereby making continuous nerve conduction pain relief accessible for more patients.

[0025] Yet another advantage is to provide a catheter with a lateral port configured to minimize occlusion rate when compared to a catheter with only a distal opening.

55 [0026] Still another advantage is to provide a catheter with a pre-formed resilient distal portion to allow the distal portion of the catheter to be positioned at least partially around a nerve, thereby permitting delivery a pharmacological agent more effectively around the entire nerve as compared to infusion from a straight catheter than is positioned at a single point. In a preferred embodiment, at least one lateral port is positioned near or on an apex of a curved portion of the

catheter.

[0027] Yet another advantage is to provide a catheter with a thickened or roughened proximal segment of catheter, thereby minimizing leakage of infused medication by wedging the catheter into the skin opening at the insertion site. Leakage of medication tends to loosen the dressing and increase the chance of accidental dislodgement.

[0028] Still yet another advantage is to stimulate a needle while using the catheter as the insulator. This permits a single attachment point for the nerve stimulator while reducing procedural steps and also simplifies manufacturing by eliminating the redundant insulating coating for the stimulating needle.

[0029] Yet still another advantage is to provide a guidewire for catheter positioning. The guidewire may include a pre-shaped distal tip configure to allow a catheter to track this geometry. Typically, a catheter does not readily move into the predetermined position because of a lack of space caused by tissue surrounding the nerve(s) and utilizing a guide wire can eliminate this problem. In addition, a directional guide wire may be utilized. The directional guide wire is known in the art and may be smaller and stiffer which permits easier positioning around the nerve(s) in a curved orientation and would then allow for the catheter to follow the tract of the guide wire. Moreover, an integrated guide wire with a needle may be utilized. This type of configuration allows for single handed deployment of guide wire by advancing the tab on the needle hub, also reducing procedural steps by not having to detach the syringe before advancing guide wire. This can also be a methodology differentiation.

[0030] Additional features and advantages of the invention will be set forth in the description which follows, and in part will be apparent from the description, or may be learned by practice of the invention. The objectives and other advantages of the invention will be realized and attained by the structure particularly pointed out in the written description and claims hereof, as well as the appended drawings.

[0031] Additional features and advantages of the invention will be set forth in the description which follows, and, in part, will be apparent from the description, or may be learned by practice of the invention. The objectives and other advantages of the invention will be realized and attained by the structure particularly pointed out in the written description and claims hereof, as well as the appended drawings.

[0032] To achieve these and other advantages and in accordance with the purpose of the present invention, as embodied and broadly described, the apparatus includes a sheath, also referred to as a catheter having a proximal end, a distal end and at least one lumen extending from the proximal end to the distal end. The sheath may also include an embedded conductive element for transmitting an electrical signal from a proximal portion of the sheath to a distal portion of the sheath. A cannula, also referred to as a needle or introducer, is arranged in the at least one lumen of the sheath and has a distal end protruding from a distal portion of the sheath. The cannula is electrically coupled to at least a portion of the embedded conductive element and is configured to provide nerve stimulation.

[0033] In another aspect, the disclosure is directed towards a method for administering a continuous flow or intermittent bolus of anesthetic agent to facilitate a continuous or prolonged nerve block. The method includes providing a sheath having a proximal end, a distal end and at least one lumen extending throughout a portion of the sheath. The sheath includes an embedded conductive element for transmitting an electrical signal from a proximal portion of the sheath to a distal portion of the sheath, or in another embodiment, the sheath provides for insulation of the electrical signal along the shaft of the needle. The method includes providing a cannula into at least one lumen of the sheath.

[0034] The method further includes connecting a syringe configured to administer a pharmacological agent to the proximal end of the cannula and coupling an electrical signal generator to the embedded conductive element or the proximal portion of the needle. Next, the cannula and sheath are inserted simultaneously into the patient. The method includes locating at least one nerve of the patient with at least one of an electric signal generated from the electrical signal generator or an active imaging device and administering a pharmacological agent to the at least one nerve after which advancing and positioning the sheath off of the cannula with a single hand of a single user. If necessary, a guide wire can be deployed to direct the catheter into a curved position around the nerve(s).

[0035] Yet another embodiment of the invention is directed towards a kit, e.g., a medical package. The kit includes an apparatus for administering a continuous flow or intermittent bolus of anesthetic agent to facilitate a continuous or prolonged nerve block and directions for use. The kit may optionally include a pump for administering a pharmacological agent, e.g., a disposable infusion pump.

[0036] Yet another embodiment is directed towards a kit, wherein the kit includes sterilized and recycled apparatuses, such as a recycled infusion pump.

[0037] Yet another example is directed to a method of introducing fluid to a nerve bundle of a patient. The method includes the steps of providing an introducer within a catheter, wherein the introducer protrudes out the distal tip of the catheter; piercing the skin of the patient with the introducer; advancing the introducer and the catheter through the patient's tissue to a nerve bundle; removing the introducer from within the catheter, while leaving a distal end of the catheter around the nerve bundle; and introducing fluid to the nerve bundle through the catheter.

[0038] Yet another embodiment is directed to a system for the delivery of a fluid to a nerve bundle of a patient. The system includes a fluid pump; a length of tubing securable to said pump; an introducer; and a catheter, wherein an introducer fits within the catheter; wherein said pump, said length of tubing, said catheter and said introducer are provided

together as a kit.

[0039] Yet another embodiment is directed to a device for dispensing fluid to a patient comprising: a catheter, wherein an introducer fits within the catheter for insertion of the device into the patient and wherein the catheter is connected to a pump; and the pump, comprising: a compact portable dispensing apparatus for dispensing a liquid under pressure at a substantially constant flow rate over a period of time comprising:

an elongated substantially cylindrical support member; elongated elastic sleeve device mounted on and sealingly secured at fixed spaced longitudinal positions on said support member for defining a pressure reservoir for holding a liquid in a pressurized state for dispensing therefrom; housing device comprising a substantially spherical rigid housing formed of like half-shells hinged together for removeably containing said support member and said pressure reservoir for enabling said pressure reservoir to expand naturally and for confining said reservoir to fill concentrically about said support member; inlet device for introducing a liquid into said elastic pressure reservoir; and outlet device for dispensing liquid from said pressure reservoir to a selected site.

[0040] It is to be understood that both the foregoing general description and the following detailed description are exemplary and explanatory, and are intended to provide further explanation of the invention as claimed.

BRIEF DESCRIPTION OF THE DRAWINGS

[0041] The accompanying drawings, which are included to provide a further understanding of the invention and are incorporated in and constitute a part of this specification, illustrate embodiments of the invention and together with the description serve to explain the principles of the invention.

[0042] In the drawings:

- FIG. 1 illustrates an operational systematic view of a continuous anesthesia nerve conduction system according to an embodiment of the invention;
- FIG. 2A illustrates a perspective view of a continuous anesthesia nerve conduction apparatus according to another embodiment of the invention;
- FIG. 2B illustrates a cross-sectional view of the continuous anesthesia nerve conduction apparatus shown in FIG. 2A;
- FIG. 3A illustrates a perspective view of a continuous anesthesia nerve conduction apparatus according to another embodiment of the invention;
- FIG. 3B illustrates a cross-sectional view of the continuous anesthesia nerve conduction apparatus shown in FIG. 3A;
- FIG. 3C illustrates an enlarged view of the distal section of the conduction apparatus according to FIG. 3A;
- FIG. 4 illustrates an enlarged view of a distal section of a conduction apparatus according to another embodiment of the invention;
- FIG. 5 illustrates an enlarged view of a distal section of a conduction apparatus according to another embodiment of the invention;
- FIG. 6A illustrates a perspective view of a continuous anesthesia nerve conduction apparatus according to another embodiment of the invention;
- FIG. 6B illustrates an enlarged view of a distal section of the continuous anesthesia nerve conduction apparatus of FIG. 6A in various configurations;
- FIG. 7 illustrates an infusion pump;
- FIG. 8 illustrates a cross-sectional view of the infusion pump of FIG. 7;
- FIG. 9 illustrates an infusion pump;
- FIG. 10 illustrates a cross-sectional view of the infusion pump of FIG. 9;
- FIG. 11 illustrates an infusion pump;
- FIG. 12 illustrates a top view of the infusion pump of FIG. 11, without the cover;
- FIG. 13 illustrates a cross-sectional view of an infusion pump in a collapsed configuration;
- FIG. 14 illustrates a cross-sectional view of the infusion pump of FIG. 13 in the inflated configuration;
- FIG. 15A illustrates an embodiment of a catheter tip;
- FIG. 15B illustrates another embodiment of a catheter tip;
- FIG. 16 illustrates an embodiment of a single handed catheter advancing device;
- FIG. 17A illustrates a single handed catheter advancing device according to another embodiment;
- FIG. 17B illustrates a perspective view of a single handed catheter advancing device illustrated in FIG. 17A;
- FIG. 17C illustrates a perspective view of a single handed catheter advancing device illustrated in FIG. 17A with a catheter;
- FIG. 18 illustrates the single handed catheter advancing device of FIG. 17C in use;
- FIG. 19A illustrates an embodiment of a solid introducer;

FIG. 19B illustrates the solid introducer of FIG. 19A in a catheter;
 FIG. 20 illustrates an embodiment of a hollow introducer in a catheter;
 FIG. 21 illustrates an embodiment of a guide wire;
 FIG. 22A illustrates another embodiment of a hollow introducer in a catheter with a sleeve;
 FIG. 22B illustrates another embodiment of a guide wire in a catheter with a sleeve;
 FIG. 23 illustrates another embodiment of a continuous anesthesia nerve conduction apparatus;
 FIG. 24 illustrates an embodiment of an insert for connection of an electrical nerve stimulator to the needle;
 FIG. 25A illustrates a perspective view of a continuous anesthesia nerve conduction apparatus according to another
 embodiment of the invention in first orientation;
 FIG. 25B illustrates the continuous anesthesia nerve conduction apparatus of FIG. 25A in a second orientation;
 FIG. 25C illustrates a guidewire according to another embodiment of the invention;
 FIG. 25D illustrates a guidewire according to another embodiment of the invention;
 FIG. 26A illustrates a perspective view of a continuous anesthesia nerve conduction apparatus according to another
 embodiment of the invention;
 FIG. 26B illustrates a cross-sectional view of the continuous anesthesia nerve conduction apparatus according to
 FIG. 26A;
 FIG. 27A illustrates a perspective view of a continuous anesthesia nerve conduction apparatus according to another
 embodiment of the invention;
 FIG. 27B illustrates a cross-sectional view of the continuous anesthesia nerve conduction apparatus according to
 FIG. 27A
 FIG. 28A illustrates a distal end of a continuous anesthesia nerve conduction apparatus according to another
 embodiment of the invention;
 FIG. 28B illustrates a distal end of a continuous anesthesia nerve conduction apparatus according to another
 embodiment of the invention;
 FIG. 29 illustrates exemplary supplies of a single sterile device package according to an example of the invention;
 FIG. 30 illustrates the localized sterilization of a patient's skin according to an example of the invention;
 FIG. 31 illustrates the anesthetizing of a patient, while simultaneously imaging the patient according to an example
 of the invention;
 FIG. 32 illustrates an operator inserting the needle and catheter into the patient according to an example of the
 invention;
 FIG. 33 illustrates an operator hydrodissecting the tissue of a patient according to an example of the invention;
 FIG. 34 illustrates the positioning of the catheter, while simultaneously imaging the patient according to an example
 of the invention;
 FIG. 35 illustrates injecting a pharmacological agent into a patient through the catheter according to an example of
 the invention;
 FIG. 36 illustrates attaching tubing to the catheter hub according to an example of the invention; and
 FIG. 37 illustrates the catheter being secured to the patient according to an example of the invention.

DETAILED DESCRIPTION OF THE ILLUSTRATED EMBODIMENTS

[0043] Aspects of the invention relate to novel medical apparatuses and methods for placement of a continuous nerve conduction catheter for prolonged neural blockage in the area of providing patients with pain relief. The apparatus can be placed with minimally involved methodology that requires only a single operator, particularly when assisted by ultrasound guidance, allowing for continuous visualization or by other means known in the art.

[0044] In one embodiment, the apparatus includes a sheath having a proximal end, a distal end and at least one lumen extending from the proximal end to the distal end. The terms sheath and catheter are used interchangeably throughout the specification. The sheath may also include an embedded conductive element for transmitting an electrical signal from a proximal portion of the sheath to a distal portion of the sheath. The sheath may be reinforced or not reinforced in any of the embodiments of the invention. A cannula or introducer is arranged in at least one lumen of the sheath and has a distal end protruding from a distal portion of the sheath. The terms cannula, needle, and introducer are used interchangeably throughout the specification. The cannula is electrically coupled to at least a portion of the embedded conductive element and may be configured to provide nerve stimulation independently or in conjunction with the sheath.

[0045] The cannula may include a sharp tip, a short beveled tip, and/or a touby tip. The cannula may be hollow or solid. The cannula as described with reference to U.S. Patent Application Publication No. 2011/0112511, which is hereby incorporated by reference as if fully set forth herein, may be used.

[0046] The sheath may be constructed as a reinforced catheter with various materials. For example, the sheath may include polyesters; polyurethanes; polyamides; polyolefins including polyethylene and polypropylene; and any copolymers thereof. Some more specific examples of suitable materials include, but are not limited to: nylon; polyester elastomer;

polyether/block polyamide, such as Pebax, Hytrel, and/or Arnitel; polyamid such as Grilamid; flouro-polymer, such as Kynar; polyether ether ketone (PEEK); polyethylene (PE); polyurethane; polyolefin copolymer (POC); tetrafluoroethylenes, such as polytetrafluoroethylene (PTFE). In a preferred embodiment, the sheath is reinforced with materials configured to substantially prevent kinking of the sheath.

5 [0047] The catheter may also be constructed, in whole or in part, utilizing a variety of degradable materials, polymeric materials, synthetic or natural, and combinations thereof. Furthermore, the catheter may be composed such that the portion of the catheter that enters and remains in the patient is degradable, but the portion that remains substantially outside of the patient is not degradable. Furthermore, a break point may exist between the two materials to assist in separating the catheter, e.g., leaving the degradable portion in the body while the non-degradable is removed. In this type of arrangement the patient would not have to return to the physician to remove the catheter.

10 [0048] Degradable materials include bioabsorbable materials, e.g. such as, polymers and copolymers composed from varying amounts of one or more of the following monomer examples, glycolide, d,l-lactide, l-lactide, d-lactide, p-dioxanone (1,4-dioxane-2-one), trimethylene carbonate (1,3-dioxane-2-one), ϵ -caprolactone, γ -butyrolactone, δ -valerolactone, 1,4-dioxepan-2-one, and 1,5-dioxepan-2-one.

15 [0049] In another embodiment, the invention is directed towards a method for administering a continuous flow or intermittent bolus of anesthetic agent to facilitate a continuous or prolonged nerve block. The method includes providing a sheath having a proximal end, a distal end and at least one lumen extending throughout a portion of the sheath. The sheath may include an embedded conductive element for transmitting an electrical signal from a proximal portion of the sheath to a distal portion of the sheath. The method includes providing a cannula into at least one lumen of the sheath.

20 [0050] The continuous anesthesia nerve conduction apparatus is configured to allow a physician to perform the procedure within about ten minutes or less, and preferably within about five minutes or less. With a minimal sterile setup, and easy identification of the targeted nerve(s), positioning the cannula adjacent to the nerve(s) permits the sheath positioning with a single hand in one continuous motion.

25 [0051] The method further includes connecting a syringe configured to administer a pharmacological agent to the distal end of the cannula and coupling an electrical signal generator to the embedded conductive element or to the cannula directly. Next, the cannula and sheath are inserted simultaneously into the patient. The method includes locating at least one nerve of the patient with at least one of an electric signal generated from the electrical signal generator or an active imaging device and administering a pharmacological agent to the at least one nerve after advancing and positioning the sheath off of the cannula with a single hand. If needed, a guide wire is directed through the lumen of the cannula to position the sheath in a semi-circumferential near the nerve(s).

30 [0052] Yet another embodiment of the invention is directed towards a kit, e.g., a medical package. The kit includes an apparatus for administering a continuous flow or intermittent bolus of anesthetic agent to facilitate a continuous or prolonged nerve block and directions for use. The kit may optionally include a pump for administering a pharmacological agent, e.g., a disposable infusion pump. Disposable infusion pumps are known in the art such as the ON-Q[®] C-bloc-Continuous Nerve Block System by I-Flow Corporation, PainPump 1, PainPump 2, PainPump 2 BlockAid by Stryker Corporation, and GoPump[®] or GoBlock[®] by Symbios. In some embodiments, the kit includes items that have been sterilized and recycled. These items may include for example, portions of the pump and exterior components such as clips and luers. Several configurations of the pump may be used, including pumps described in U.S. Patent Nos. 5,284,481; 7,322,961; 5,352,201 and 5,080,652, each of which is incorporated herein by reference in their entirety.

35 [0053] Reference will now be made in detail to an embodiment of the present invention, example of which is illustrated in the accompanying drawings.

40 [0054] FIG. 1 illustrates an operational systematic view of continuous anesthesia nerve conduction system according towards an embodiment of the invention.

45 [0055] Referring to FIG. 1, the system is generally depicted as reference number 100. The system overview 100 includes an exterior portion of a sheath 102. The sheath 102 is secured to the skin of the patient with securing tab or tabs 103 and anchored to a hub 104. Nerve(s) 106 lying deep to tissue below the exterior surface of the patient are targeted to receive a pharmacological agent. A subcutaneous distal portion of the sheath 108 is shown positioned in close proximity to the targeted nerve(s) 106, e.g., nerves of the brachial plexus. The sheath 108 may include a side port and markings to aid with external visualization, e.g., active or passive visualization. The markings may be spaced apart to aid in further visualization and orientation of the side port as shown in FIGS. 28A and 28B.

50 [0056] An infusion pump 110 which may be filled with a pharmacological agent, e.g., pain medication, is connected to the apparatus via connecting tubing 112, by way of example, with Luer locking connectors to the hub 104. The pump 110 can include a ON-Q[®] C-bloc- Continuous Nerve Block System by I-Flow Corporation, PainPump 1, PainPump 2, PainPump 2 BlockAid by Stryker Corporation, and GoPump[®] or GoBlock[®] by Symbios. For example, the pump may include a pump as described in U.S. Patent Nos. 5,284,481; 7,322,961; 5,352,201 and 5,080,652, each of which is incorporated herein by reference in their entirety. Several different configurations of the tubing may be used. For example, a coupler may be used so that the pharmacological agent in the pump may be directed to multiple locations in the body. In addition, multiple catheter units may be used and different configurations of the catheter may also be used.

5 [0057] Several different configurations of the pump 110 may be used. In a preferred embodiment, a disposable pump, infusion pump and other inexpensive pumps as known in the art may be used with a continuous anesthesia nerve conduction apparatus. An infusion pump 110 such as that described in U.S. Patent No. 5,284,481, incorporated herein by reference, may be used. FIGS. 7 and 8 illustrate exemplary embodiments of infuser pumps. The infuser pump, designated generally

10 by the numeral 710, is collapsible and includes an outer collapsible substantially non-stretchable housing or shell 712, protectively mounted over a combined reservoir and support assembly constructed substantially like that set forth in U.S. Pat. Nos. 5,080,652 and 5,105,983, each of which are incorporated herein by reference as though fully set forth herein.

[0058] The collapsible housing 712 has a substantially spherical configuration for confining and guiding the inflatable reservoir or bladder into a concentric position around the central support member, and enabling it to expand naturally in a spherical configuration as will be described. However, other geometric configurations are also possible for the collapsible housing. The collapsible housing 712, as seen in FIG. 8, has coaxial openings defined by tubular sleeve extensions 714 and 716 through which the ends of a central support member 718 extends.

15 [0059] An elastic membrane or bladder assembly 720 forming an inflatable reservoir, such as described in the aforementioned patents, is mounted on the cylindrical support member 718. The bladder assembly 720 may be a single sleeve or multiple sleeves. This is preferably with an inner sleeve being a chemically inert sleeve, and the outer sleeve or sleeves being highly elastic.

20 [0060] The central cylindrical support member or mandrel 718 includes circular grooves only one of which, 722 is shown, at the ends thereof into which portions of the sleeve 720 and housing 712 are biased with a pair of O-rings, only one of which, 726, is shown. The collapsible housing 712 is preferably a non-stretch blow molded housing of from five to ten mil-inches in thickness and made of a material such as polyurethane, PVC film, and/or polyethylene and is transparent. This forms a simple inexpensive compact unit with a certain amount of protection for the elastic reservoir.

25 [0061] Certain applications may require a tougher collapsible housing. In such cases, the housing can be transparent, UV stable, flexible and highly resistant to puncturing. In this configuration, the housing would be constructed of a material such as tough composites in a flexible form such as a fabric, reinforced thermoplastic, Kevlar material which includes a para-aramid synthetic fiber, related to other aramids such as Nomex and Technora, and combinations of the same.

[0062] The ends of the central support member 718 include reduced diameter extension 730 and 732, with bayonette type couplings for releasably coupling cup-shaped caps 734 and 736 which extend over and protectively cover the O-ring connections or clamping of the elastic bladder and collapsible housing to the support member.

30 [0063] The support member 718 has an inlet or fill port 742 on one end which communicates with a coaxial passage 744, and a transverse passage 746 in which is mounted a check valve 748. The cross bore 746 communicates with passage 744 and inlet port with the interior of the elastic bladder or sleeve 720 and thus the interior of the inflatable reservoir. The check valve is also used and is of a generally cylindrical outer shape, with a square bore extending from one end and closed at the other forming a cup-shaped structure. The check valve may be constructed of materials known

35 in the art, e.g., an elastomer like silicone, and collapses inward to allow filling and erects to its normal configuration to prevent back flow. The square bore configuration of the bore insures that it returns to its normal configuration and does not remain collapsed.

[0064] An outlet port through end 732 communicates with a passage 754 that extends coaxially from the other end of the support member 718, and communicates with a cross bore or port 756 with the interior of the elastic bladder or reservoir 720. The port 756 may include a sensor 711 to measure flow rate, pressure, liquid volume, and temperature among other characteristics. Multiple sensors may also be used throughout the interior. These sensors may be configured to communicate wirelessly via Wi-Fi, Bluetooth, and other wireless communication protocols as known in the art to a readout or other device (not shown) such as a controller. Of course, the sensors may be hardwired to communicate directly with a readout or other internal or external device.

40 [0065] A tubing set, as shown in FIG. 7 including a tube 752 having a filter 758 and a connector 760 at the end, provides a device for connecting and dispensing a fluid to a desired location, such as a catheter (FIG. 1) as described herein. The connector 760 may be permanently attached to the tube 752, or may be removable. Furthermore, any suitable connector may be used, including a luer connector or others as known in the art.

45 [0066] The collapsible infuser apparatus of FIGS. 7 and 8 is a compact and inexpensive disposable unit. It has a compact configuration, with a collapsed diameter no greater than the outer diameter of the caps 734 and 736. For this reason, it is convenient to package in a kit as described herein. Optionally, it may be temporarily housed during use in a protective hard shell housing.

50 [0067] In another embodiment, the pump 110 may be the pump described in U.S. Patent No. 7,322,961, which is hereby incorporated in its entirety by reference. FIGS. 9 and 10 illustrate an infusion pump or apparatus, generally referred to by the reference numeral 910. The infusion apparatus 910 is operable to deliver a pressurized liquid, such as a pharmacological agent, e.g., pain medication, to a desired site such as a catheter (FIG. 1). Preferably, the infusion apparatus 910 is relatively inexpensive, portable and provides reliable operation throughout its useful life. The infusion apparatus 910 may be reusable or may be disposable after a single use.

[0068] The infusion apparatus 910 desirably includes an infusion pump 912, which is configured to hold a pressurized supply of a fluid, such as a pharmacological agent. Preferably, a supply arrangement 914 includes in substantial part by a length of medical tubing 916, is in fluid communication with the infusion pump 912 at a first end. The supply arrangement 914 supplies the pressurized fluid to the catheter or other delivery device, through an appropriate connection device 918 at a second end. The medical tubing 916 may be formed of any of a variety of materials suitable for use in medical applications. Preferably, such materials are constructed from a polymeric material and substantially bio and/or chemically inert. Similarly, the connector 918 may be any suitable device to permit relatively quick and secure connection between a pair of medical devices, such as a luer lock, for example. Other types of suitable connectors may also be used.

[0069] In a preferred embodiment, the supply arrangement 914 includes a filter 920 in serial connection with the medical tubing 916. The filter 920 desirably is configured to remove impurities, including air bubbles, from the fluid delivered from the infusion pump 912. The filter 920 may be any suitable medical filter as known in the art.

[0070] Preferably, the supply arrangement 914 also includes a clamp 922, which is desirably positioned upstream of the filter 920. The clamp 922, in a closed position, is configured to apply a squeezing pressure to the medical tube 916 to close the lumen therein and occlude fluid flow beyond the clamp 922. Any suitable type of medical clamp may be used.

[0071] With reference to FIG. 10, the infusion pump 912 generally includes an elastic sleeve 924 surrounding a support member. Preferably, the support member 926 is generally cylindrical in shape, however, other suitable shapes of support members may also be used. The elastic sleeve 924 is expandable in a radial direction about the cylindrical support member to an expanded condition 924a. In the expanded condition 924a, the elastic sleeve 924 and the support member cooperate to define a variable volume fluid reservoir 928 therebetween.

[0072] Preferably, the infusion pump 912 is configured such that the reservoir 928 may be filled (also referred to as "loading" the pump 912), from an inlet end 926a of the support member. Preferably the infusion pump 912 may be manually loaded with a loading device, such as a syringe. Once the reservoir 928 has been filled with fluid, the elastic nature of the sleeve 924 exerts a pressure on the fluid within the reservoir 928, permitting the fluid to be delivered to a desired site catheter through the supply arrangement 914 and delivery device (FIG. 1).

[0073] The sleeve 924 may include a single layer or multiple layers. The inner sleeve 924a may include a bio and/or a chemically inert material to avoid interaction with the drug within the infusion pump 912 while an outer sleeve 924b may include a material having desirable elastic properties. The combination of the sleeves 924a, 924b desirably provide satisfactory elastic properties and desirable chemical properties to consistently and safely deliver the pressurized fluid, such as a pain medication. In one arrangement, the inner sleeve 924a may include a semi-elastic thermal plastic material. The outer sleeve 924b may include a natural latex rubber material, which provides desirable elastic characteristics. However, other suitable materials may also be used.

[0074] If desired, the infusion pump 912 may also include a protective, collapsible housing, or pouch 930 surrounding the elastic sleeve 924. Desirably, the pouch 930 is relatively inelastic to limit expansion of the sleeve 924. In addition, the pouch 930 desirably is made from a tougher material than that of the sleeve 924 in order to protect the sleeve from punctures, or other damage. In one preferred arrangement, the pouch 930 includes a pair of flat, sheet-like portions bonded to one another around their peripheral edges. Preferably, the portions of the pouch 930 comprise a PVC material, which are bonded to one another by Radio Frequency (RF) welding. Such a construction provides a suitable, economical means to protect the elastic sleeve 924 from damage. Other suitable materials and construction techniques may also be employed.

[0075] Desirably, the elastic sleeve 924 is sealed to the cylindrical support member 926 at spaced apart locations near each end 926a, 926b of the cylindrical support 926 by a pair of seal assemblies 932 (only one shown). The reservoir 928 of the infusion pump 912 is defined between the pair of seal assemblies 932. If a housing or pouch 930 is provided, end portions thereof may also be held in place by the seal arrangement 932. These and other details of the sealing arrangements 932 are described in greater detail below.

[0076] Desirably, a cap 934 is attached to each end of the infusion pump 912. Preferably, each cap 934 includes a side wall portion which at least partially covers the sealing arrangement 932. Such an arrangement serves to inhibit damage to the sealing arrangement 932 during normal use of the infusion apparatus 910 and provides an aesthetically pleasing outward appearance. Other sealing mechanisms may be used.

[0077] The cap 934 is removably connectable to the support member 926. In a preferred embodiment, the cap 934 is coupled to the support member 926 by a snap fit arrangement wherein the cap 934 includes a triangular-shaped cutout 936. The cutout 936 is sized such that a portion of each side of the triangular-shaped cutout 936 may be received within an annular recess defined by the cylindrical support member 926. Desirably, the cap 934 is constructed from a material having sufficient flexibility such that the side portions of the cutout 936 may deflect to pass over the end portion of the support member 926, which has a larger diameter and is positioned outwardly, along the support member 926, from the recess. Any of a variety of common thermoplastic materials may be suitable for use in construction of the end cap 934. Other suitable end cap constructions may be used, such as a threaded end cap arrangement, plug, and the like.

[0078] The infusion pump 912 also includes an inlet 940 and an outlet 942 in fluid communication with the reservoir 928. In the illustrated embodiment, the inlet 940 and outlet 942 are at least partially defined by the support member 926.

Desirably, each of the inlet and outlet 940, 942 include a longitudinally extending channel 944, 946, respectively, which open to opposing end surfaces of the support member 926. In addition, each of the inlet and outlet 940, 942 include a radially extending channel 948, 950, respectively, which communicate with the longitudinal channels 944, 946 and open from a portion of the side wall of the cylindrical member 926 located within the fluid reservoir 928, or the reservoir wall.

5 A sensor 911 to measure flow rate, pressure, liquid volume, and temperature among other characteristics. Multiple sensors may also be used throughout the interior of the infusion pump 912. These sensors may be configured to communicate wirelessly via Wi-Fi, Bluetooth, and other wireless communication protocols as known in the art to a readout or other device (not shown) such as a controller. Of course, the sensors may be hardwired to communicate directly with a readout or other internal or external device.

10 **[0079]** The inlet-defining end 926a of the support member 926 desirably is configured to receive a reservoir loading device, such as a syringe, which may be interconnected to the support member 926 by a threaded connection, such as a luer lock connection, for example. In operation, the loading device introduces fluid into the fluid reservoir 928, against the biasing force of the sleeve 924. Desirably, once the infusion pump 912 has been loaded with fluid, the inlet end of the support member 926 is closed by a cap 952. The elasticity of the sleeve 924, once expanded 924a, pressurizes the fluid within the reservoir 928.

15 **[0080]** Preferably, the inlet 940 includes a one-way valve to inhibit fluid within the reservoir 928 from escaping through the inlet 940. The valve includes a valve member 954 positioned within the radially extending channel 948. The valve member 954 is desirably cylindrical in shape and includes a recess extending, from an end surface, along a longitudinal axis of the valve member 954. Preferably, the recess is generally square in cross-section and extends substantially the entire length of the valve member 954, thereby defining a closed end of the valve member 954 having a thickness approximately equal to a thickness of the outer wall portion of the valve member 954.

20 **[0081]** When installed in the radially extending channel 948, a portion of the wall of the valve member 954 facing the longitudinal channel 944 collapses in response to fluid being loaded in the infusion pump 912 through the inlet 940. However, once the fluid pressure within the inlet 940 is lower than the pressure within the reservoir 928 (i.e., filling of the reservoir 928 has ceased), fluid within the recess urges the valve member 954 back into its original, cylindrical orientation to inhibit fluid from entering the longitudinal channel 944 and, thus, exiting the reservoir 928 through the inlet 940. Other suitable valves may also be used as known in the art.

25 **[0082]** Desirably, the longitudinal channel 946 of the outlet 942 extends through an outlet end 926b of the support member 926 and communicates with the medical tubing 916 of the supply arrangement 914. Desirably, the outlet 942 permits relatively unobstructed fluid flow. That is, a one-way valve mechanism is not necessary or desirable in connection with the outlet 942. Accordingly, with such an arrangement, fluid flow from the reservoir 928 through the outlet 942 is selectively permitted by the clamp 922 of the supply arrangement 914.

30 **[0083]** Optionally, the pump 912 may include a flow restrictor (not shown) downstream from the fluid reservoir 928. The flow restrictor is configured to restrict the flow rate of fluid exiting the fluid reservoir 928 to a desired level. The flow restrictor may comprise a reduced-diameter of the outlet passage 946 (in whole or in part), the diameter of the tubing 916 (FIG. 9), or a separate flow restrictor device positioned downstream from the fluid reservoir 928. Other suitable arrangements are also possible, including a combination of the above-mentioned flow restrictor arrangements.

35 **[0084]** The seal arrangement 932 is described in greater detail. The seal arrangement 932 desirably includes an annular recess, or groove 958, near an end of the support member 926. The recess 958 is defined by an outer surface of the support member 926 and, preferably, is substantially semi-circular in shape. A generally annular spring clip 960 is sized to be positionable onto the support member 926 and, preferably, cooperate with the recess 958 to create a seal between the sleeve 924 and the support member 926.

40 **[0085]** The spring clip 960 is configured to be movable from a relaxed position, or a free diameter of the spring clip 960, to a deflected position. In the relaxed position, an inner diameter of the spring clip 960 desirably is smaller than a diameter of the support member 926 with which the spring clip 960 is positioned. In the deflected position, the inner diameter of the spring clip 960, desirably, is large enough to pass over the elastic sleeve 924 and cylindrical support member 926 to permit assembly onto the infusion pump 912. Once released, the spring clip 960 returns toward the relaxed position. Preferably, the support member 926 is sized such that the spring clip 960 is prevented from returning to the fully relaxed position. Accordingly, the spring clip 960 exerts a squeezing force on the elastic sleeve 924 to create a seal between the sleeve 924 and the cylindrical support member 926 thereby defining an end of the fluid reservoir 928. As will be appreciated by one of skill in the art, the squeezing force developed by the spring clip 960 may be adjusted to a desired level by altering the relative sizes of the inner diameter of the spring clip 960 and the outer diameter of the corresponding portion of the support member 926, as well as by altering the properties of the spring clip 960 itself, such as the coil diameter of the spring clip 960, for example.

45 **[0086]** Desirably, the elastic sleeve 924 (and pouch 930, if provided) is biased into the recess 958 by the spring clip 960. Such an arrangement assists in defining and maintaining a proper position of the spring clip 960 relative to the support member 926. In addition, the deflection of the sleeve 924 into the recess 958 increases the effectiveness of the seal arrangement. Although only the inlet side 926a seal arrangement 932 is shown, preferably the outlet side 926b is

constructed substantially similarly to that of the inlet side 926a. Preferably, the spring clip 960 is constructed of metal, however, other suitable materials such as plastics may also be used.

5 [0087] In another embodiment, the system may include a pump 110 as described in U.S. Patent No. 5,352,201, which is incorporated in its entirety by reference. FIGS. 11 and 12 illustrate the infusion pump or apparatus, generally referred to by the reference numeral 1010. The infusion apparatus is embodied in a housing having a generally flat spiral configuration. However, it may have other outer configurations such as circular, semicircular or square. The apparatus includes a main housing having thermally formed walls extending upward from a bottom and extending in a radially outward spiral to a terminal end such that all the connections are provided. The main housing has an open top formed for receiving a generally flat planer cover 1014. The cover 1014 may be formed with recesses or other structural configurations to enable stacking of a plurality of the units.

10 [0088] The housing is preferably formed of any one of a number of thermoformable plastic polymer materials and vacuum formed into its shape or configuration. Either the housing 1012 or the cover 1014 or both may be of a transparent material. Preferably at least one is transparent in order to enable viewing the components in the interior of the housing. They may also be formed together of the same material with an integral hinge connection as will be explained. Referring to FIG. 12, the main housing is shaped to form a spiral bladder support and chamber from a central point of the housing spiraling outward to the terminal outlet face of the housing. The housing is formed of an inner wall 1016 beginning at an inner end 1018 proximate the center of the housing and spiraling outward in a radially outwardly spiral to become an outer wall and continue to a terminal end 1022, joining the outer surface or portion thereof and forming a terminal wall 1024. The angle subtended by the spiral is preferably in a range from about 3/4 turn and about 2 turns or greater.

20 [0089] The inner wall 1016 forms a spiral support structure for supporting an elongated elastic tubular member 1026 forming an elastic bladder or reservoir. The coils of the elastic tube are supported in a common plane and spiral radially outward. The elastic tube or member 1026 is preferably pre-stretched up to about 30% with an inner end 1028 secured on a barbed plug 1030 having a shoulder 1032. The shoulder 1032 is positioned behind shoulders formed by inner extending wall portions 1034 and 1036 forming a receptacle for receipt of the plug 1030. The elastic tube or member is stretched and bends across the inner end 1018 or wall of mounting member 1016 and lies compressed substantially flat, as it extends along the wall to an outlet end 1038 connected to an outlet connector and valve assembly including a suitable coupling or connector such as a luer connector 1040.

25 [0090] The housing of the valve and connector assembly is of a tubular configuration with an inner barbed connector 1042 over which an outer end 1038 of elastic tube 1026 is mounted. The housing of the connector includes spaced apart disc or shoulder plates 1044 and 1046 which embrace and engage opposing sides of the wall 1024 as the connector is inserted in a slot 1048 therein. This secures the connector in place against movement either inward or outward of the housing. The elastic bladder 1026 is stretched and mounted between barbed connectors 1030 and 1042.

30 [0091] The connector assembly 1040 preferably includes a luer check valve of a type for such fittings normally available from the Halkey-Roberts Company of St. Petersburg, Fla. The valve (not shown) is a one-way check valve to prevent outflow until a luer connector is mounted on the outlet end of the connector which acts to release or unseat the valve.

35 [0092] The housing may be constructed of any number of suitable engineering thermo forming materials such as, acrylonitrile butadiene-styrene (ABS), polyvinylchloride (PVC), polyethylene terephthalate (PET), polyethylene terephthalate glycol (PETG) and the like. These are well-known lightweight plastics and are materials approved for medical devices.

40 [0093] The tubular member 1026 is preferably constructed of an inner tube or sleeve of an inert elastomer and an outer highly elastic tube or sleeve. A preferred rubber material for the inner sleeve is a thermoplastic material, e.g., rubber sold under the mark KRATON by Shell Chemical Company of Houston, Texas. These materials are available as KRATON D and G 2000 series rubber. These materials are biocompatible and have less than optimum elastic characteristics, and are referred to herein as semi-elastic. When stretched, they initially return to a position of about 75 to about 90 percent of original configuration over a reasonable period of time.

45 [0094] The outer sleeve is preferably made of a natural or synthetic highly elastic rubber such as latex, silicone or other rubber with excellent elastic characteristics, and is referred to herein as elastic. A material with good elastic characteristics returns quickly from a stretched condition to its original un-stressed or un-stretched condition. A good elastic material also has a uniform elastic force over the range stretched and returns substantially all energy put into it. A good elastic rubber can stretch in the range from about five hundred to about eight hundred percent and return most of the energy as it returns to its original position. Natural latex rubbers are a preferred material for the outer sleeve of tubular member 1026. However, certain other rubbers such as silicone rubber would also be suitable.

50 [0095] The pump 1010 may include a sensor to measure flow rate, pressure, liquid volume, and temperature among other characteristics. Multiple sensors may also be used throughout the interior. These sensors may be configured to communicate wirelessly via Wi-Fi, Bluetooth, and other wireless communication protocols as known in the art to a readout or other device (not shown) such as a controller. Of course, the sensors may be hardwired to communicate directly with a readout or other internal or external device.

55 [0096] Still another embodiment of system includes a pump 110 as described in U.S. Patent No. 5,080,652, which is

incorporated by reference in its entirety. FIGS. 13 and 14 are directed toward a pump generally depicted as reference number 1310. The pump 1310 is separate from the charging or filler pump. Moreover, it may be filled by any suitable means, such as a syringe or any other pressurizing devices or methods. The housing 1312 has a substantially spherical configuration and is provided with coaxial, or more particularly aligned bores or ports 1314 and 1316, in which is mounted an inflatable bladder assembly. The housing 1312 may be made of unitary construction, such as by blow molding, or may be of two identical half shells assembled. The ports are formed in axial recesses 1318 and 1320. The inflatable bladder assembly includes a first or inner elongated semi-elastic sleeve 1322, and a pair of outer elongated latex rubber elastic sleeves 1324 and 1326 mounted on an elongated central cylindrical support member 1328. The inner sleeve 1322 is preferably made of a drug compatibility rubber with low leach characteristics that meets USP class 6 testing standards.

[0097] A rubber material for the inner sleeve 1322 is a class of thermoplastic rubber, e.g., sold under the mark KRATON by Shell Chemical Company of Houston, Texas. These materials are available as KRATON D and G 2000 series rubber, and have FDA status for use in certain applications or ingredients of articles for food contact. These materials have less than optimum elastic characteristics, and are referred to herein as semi-elastic. When stretched, they return to a position of about 75 to about 90 percent of original configuration.

[0098] The outer sleeves 1324 and 1326 are preferably made of a natural latex rubber with excellent elastic characteristics. A material with good elastic characteristics returns from a stretched condition to its original un-stressed or stretched condition. A good elastic material also has a uniform elastic force over the range stretched. Natural latex rubbers are the preferred material for the outer sleeves membranes 1324 and 1326.

[0099] The central support member 1328 is preferably of a generally elongated cylindrical configuration, with an annular radially extending retaining flange 1330 on one end for engaging a shoulder 1332 on the housing 1312. The opposite end of the support member 1328 includes a bayonet type coupling with a retaining nut 1334. The central support member may be constructed of any suitable pharmaceutically compatible material, such as metals, plastics, glass, etc.

[0100] The support member 1328 includes an inlet port 1352 communicating by way of a passage 1354, including a one-way valve 1356, 1358 with the interior of the membrane or sleeve 1322. Any suitable check valve may be used to permit uncoupling of the filling unit without leakage of fluid from the pressurized bladder. The check valve includes a cross through bore 1356 communicating with the end of passage 1354, and in which is slip fitted an elastic tube 1358, which may be of a suitable rubber such as silicone. The tube 1358 covers the end of passage 1354 to prevent back flow from inside the bladder formed by sleeve 1322. The tube 1358 collapses in response to higher pressure in passage 1354 enabling flow of liquid into sleeve 1322.

[0101] A sensor 1311 before the valve is configured to measure flow rate, pressure, liquid volume, and temperature among other characteristics. Multiple sensors may also be used throughout the interior. These sensors may be configured to communicate wirelessly via Wi-Fi, Bluetooth, and other wireless communication protocols as known in the art to a readout or other device (not shown) such as a controller. Of course, the sensors may be hardwired to communicate directly with a readout or other internal or external device. The sensors may be configured to communicate with the flow control device 1370, e.g., a feed-back loop as known in the art.

[0102] An outlet passage 1360 in support member 1328 communicates via an outlet port 1362 and suitable coupling assembly 1364, with an outlet or intravenous feeding line including, e.g., a two-part tube 1366, which includes a filter 1368, and may include flow control device 1370 and a male luer lock adaptor. The outlet line may be controlled by a suitable valve assembly (not shown) or preferably by the well known type clamp known as a clamp 1396. The luer lock 1374 has a valve that closes the outlet port when the feeding line is uncoupled therefrom. The coupling is effective to open the outlet valve when coupled to the outlet fitting. The delivery tubes 1366 may be selected in size and length to aid in maintaining a predetermined pressure and flow rate. The luer lock is configured to attach to a catheter, e.g., as shown in FIG. 1.

[0103] The elastic sleeves 1324 and 1326 are mounted over the sleeve 1322. Sleeves 1324 and/or 1326 may be stretched radially when in position over sleeve 1322, e.g. 1324 is stretched radially over 1322, with 1326 slip fit over the assemblies of 1322 and 1324. The outer bladder 1326 slips radially over the assembly of 1322 and 1324. The composite assembly of 1322, 1324, 1326 is slideably engaged with a slip fit over the mandrel or support member 1328. Radial stretching of the bladder 1324 compensates for material 1322's less than perfect elasticity. More specifically, the wall thickness and amount of stretch of bladder 1324 are selected to just compensate for bladder 1322's material less than perfect elasticity. The initial strain conditions and bladder wall thicknesses are also chosen to minimize the non-linearity exhibited in a bladder's stress versus strain.

[0104] It is well known that a single bladder infusion device constrained at both ends exhibits a highly non-linear stress versus strain relationship. This causes a time varying flow characteristic. The inner bladder is chemically inert and the outer bladder is elastic. The structure and method for maintaining constant flow versus time while the device is infusing by radially stretching an intermediate bladder over the inner bladder.

[0105] The inner semi-elastic drug compatible tube or membrane 1322 is mounted on the cylindrical support member 1328, preferably in a slightly snug but un-stretched radial fit, and essentially relaxed elongated or non-stretched longi-

tudinal fit. The inner sleeve 1322 preferably has what shall be called a slip fit on the support member. This slip fit is preferably with a clearance of on the order of about one-thousandths of an inch of the sleeve on the support. This provides a non-stretched fit, with essentially zero volume of the pressure chamber when in the non-stretched or totally relaxed state or mode.

5 **[0106]** The elastic sleeves 1324 and 1326 are respectively stretch fit and snug fit radially over the inner semi-elastic sleeve 1322. The intermediate sleeve 1324 is radially stretched up to about five percent over the inner sleeve 1322 for compressing it. The outer sleeve 1326 is slip fitted over the intermediate sleeve 1324. All of these sleeves 1322, 1324, and 1326 are fitted over the support member 1328 and clamped at the ends with a pair of O-rings 1376 and 1378. These O-rings 1376 and 1378 bias the ends of the multiple sleeves into annular grooves 1380 and 1382 in the outer surface of the member 1328. The O-rings 1376 and 1378 are held in place by the walls of the housing forming the recesses 1318 and 1320. The multiple sleeves when being filled tend to elongate and roll over the ends thereof as shown in FIG. 14. The support member 1328 is of a fixed length and holds the ends of the sleeves at a fixed position. The multiple thin sleeves easily roll over the ends, thereof as the bladder is made up of the multiple sleeves fills and expands.

10 **[0107]** The pressure applied by the pressure chamber, formed by the multiple sleeves, will be substantially a function of the thickness of the wall of the elastic sleeve or sleeves. For example, a typical two to three (2-3) psi may be obtained by a wall thickness of about eighteen to twenty-thousandths (0.018-0.020) of an inch. In order to obtain higher pressure with superior uniformity, a multi-layered sleeve configuration as described hereinabove has been found to be preferred.

15 **[0108]** As illustrated in FIG. 13, a plurality of sleeves (three illustrated) 1322, 1323 and 1324 are slip fitted (non-stretched) on the support member. The inner sleeve 1322 is slip fitted on the support member 1328, and a second sleeve 1324 is slightly stretch fitted over the first sleeve 1322. Thereafter, a third sleeve 1326 is slip fitted over the intermediate sleeve 1324. These are shown in the fully deflated position in FIG. 13 and in the fully inflated condition in FIG. 14, showing the fold or roll over the ends. These multiple layers have been found to be superior to the use of thicker membranes or sleeves to obtain higher and uniform pressures. The use of multiple layers also enables the use of a semi-elastic substantially chemically (medically) inert inner membrane or sleeve for contact with the infusible liquid. The multiple sleeves will roll or fold over at the ends, as illustrated in FIG. 14. Thus, to increase the pressure, additional sleeves of substantially the same thickness are used.

20 **[0109]** When being filled, the elastic multi sleeve membrane has a tendency to elongate, but expands into a spherical configuration. The elongation is accommodated in this pump configuration by an accordion effect at the ends of the bladder, as shown in FIG. 14, wherein the bladder rolls over the ends thereof and outward along the support member 1328 as it expands outward to fill the housing 1312. The accommodation of the elastic membrane in the spherical configuration enables it to expand and contract in its natural fashion, and to maintain a substantially constant pressure and thereby flow rate over the intravenous injection period.

25 **[0110]** The layered or multiple sleeve configurations have been found to better accommodate the accordion fold and maintain a more uniform pressure than a thicker sleeve. The tubular elastic sleeve membranes are selected and mounted on the support member in a manner that enables them to roll or fold over at the ends when being filled.

30 **[0111]** In operation, an assembled infuser pump unit is selected, and the inlet port 1352 is secured to a source of fluid under pressure. As fluid is being introduced into the inlet, the valve 58 collapses as fluid flows into the inner sleeve or membrane 1322. As the reservoir or bladder formed by the sleeves begins to fill, it expands and attempts to elongate. The ends of the sleeves begin to fold and roll over the ends thereof as in FIG. 14. The bladder forms a substantially spherical shape as its natural form of expansion. The roll at the ends accommodates this expansion and aids in maintaining a substantially constant pressure over the range of infusion.

35 **[0112]** As the bladder deflates, the outer elastic membranes force the inner semi-elastic membrane back to substantially its original position. This helps to evacuate the entire volume of fluid. It also will be appreciated that any form of pressurized filling apparatus may be used.

40 **[0113]** FIG. 2A illustrates a perspective view of a continuous anesthesia nerve conduction apparatus according to another embodiment of the invention. FIG. 2B illustrates a cross-sectional view of the continuous anesthesia nerve conduction apparatus shown in FIG. 2A.

45 **[0114]** Referring to FIGS. 2A-2B, a continuous anesthesia nerve conduction apparatus is generally depicted with reference to number 200. The apparatus 200 includes a reinforced catheter 202 with and without the cannula 204. The beveled distal tip of the cannula 204 is shown to be protruding slightly from the distal tip of the catheter 202. The proximal portion of the catheter 202 includes winged hub 206. The cannula 204 includes a hub 207 configured to abut and engage with the winged hub 206 via a locking mechanism 208. The wings 210, 212 optionally include an adhesive configured to attach to a patient. The catheter 202 optionally includes at least one port 214. The port 214 is configured to supply a pharmacological agent in at least a radial direction from a longitudinal axis of the catheter 202. That is, the port 214 permits the distribution of the infused pharmacological agent to the targeted nerve(s) 116 in a circumferential and linear pattern at the distal end. The port 214 may be configured to have small or large diameters, e.g., a diameter in the range from about 0.1 mm to about 2 mm or greater. There also may be a plurality of ports arranged circumferentially around the perimeter of the catheter or in another geometric pattern.

[0115] The proximal hub 207 of the cannula 204 is configured to accept a tip of a standard syringe 218. The syringe 218 may be used to inject a pharmacologic agent, e.g., solution for hydro-dissection of tissue surrounding to the targeted nerve(s) 106 during catheter placement. Once in place adjacent to the targeted nerve(s) 106, the lock 208 is disengaged, the cannula 204 is withdrawn, and the catheter 202 is positioned to provide continuous nerve block.

5 [0116] The catheter hub 206 is further configured to accept a connector 219 on the end of the connecting tube 112. The connecting tube 112 is coupled to an infusion pump on the opposite end. A frictional region 220, e.g., pebbled region, is optionally added to a proximal portion of the catheter 202. The frictional region 220 is configured to aid in sealing an insertion site in the tissue, minimize leakage of contrast and/or pharmacological agent, and minimize movement of the catheter 202. The frictional region 220 may include an adhesive material including a bioresorbable material and non-bioresorbable material. The orientation and the location of the catheter 202 and its lateral port can be monitored through the use of markers, e.g., radiopaque, echogenic, combinations of the same, and the like, via visualization techniques.

10 [0117] Referring now FIG. 2B, the distal portion of the catheter 202 includes an echogenic region 222 including echogenic material to aid with ultrasound visualization of a distal tip of the catheter 202. The catheter 202 includes a lumen 226 extending from a proximal end to a distal end. The hub 206 also includes a lumen 228 in communication with the lumen 226. Finally, the cannula 204 and hub 207 of the cannula includes a lumen 230 extending from a proximal end to a distal end. The lumens 226, 228, and 230 are arranged to form one continuous lumen for administering a pharmacological agent or other medical device. The other medical device may include a balloon, active visualization device (imaging probe), surgical instrument, and the like. A reinforcement material 224, e.g., axial stays, metal and the other reinforcement material may be used for reinforcement of the catheter to minimize kinking or bending when desired. That is, the material 224 is embedded in a body of the catheter 202 to provide enhanced rigidity, thereby preventing bunching and kinking of the catheter 202. The catheter 202 may also be configured with various rigidities along a longitudinal axis of the catheter, e.g., the proximal portion may be stiffer than the distal portion and vice versa.

15 [0118] FIG. 3A illustrates a perspective view of the continuous anesthesia nerve conduction apparatus according to another embodiment of the invention. FIG. 3B illustrates a cross-section view of the continuous anesthesia nerve conduction apparatus shown in FIG.3A. FIG.3C illustrates an enlarged view of the distal section of the apparatus shown in FIG. 3A.

20 [0119] Referring to FIGS. 3A-3C, a continuous anesthesia nerve conduction apparatus is generally depicted with reference to number 300. The apparatus 300 includes a reinforced catheter 302 with and without a cannula 304. The beveled distal tip of the cannula 304 is shown to be protruding slightly from the distal tip of the catheter 302. The proximal portion of the catheter 302 includes a winged hub 306. Wings 308, 310 optionally include an adhesive configured to attach to a patient. The catheter 302 optionally includes at least one port 312. The port 312 is configured to supply a pharmacological agent, e.g., contrast, medicine, or the like, in at least a radial direction from a longitudinal axis of the catheter 302. That is, the ports 312 permit the distribution of the infused pharmacological agent to the targeted nerve(s) 116 in a circumferential and/or linear pattern.

25 [0120] The apparatus 300 further includes an embedded conductive element 314 and a conductive 316 tab. The conductive element 314 is configured to transmit electrical activity used to activate a nerve, e.g., dc current, voltage, ac current, voltage, square wave, or combination, to a distal portion of the catheter 302 and cannula 304. In a preferred embodiment, the electrical activity is generated by a nerve stimulator generator (not shown), e.g., Stimuplex® PNS11 Peripheral Nerve Stimulator by B. Braun, Stimuplex Dig RC by B.Braun, MultiStim VARIO by Pajunk, and EzStim® stimulator by Life-Tech International. In a preferred embodiment, the embedded conductive element 314 is an embedded wire.

30 [0121] An electrode cap 318 is affixed to a distal end of the catheter 302. The electrode cap 318 is coupled to the embedded wire 314 and is configured to allow for peripheral nerve(s) simultaneous stimulation via the cannula 304 and the catheter 302. The embedded wire 314 is within the body of the catheter and connects the electrode cap to the proximal electrode connector 316 on the catheter hub 306.

35 [0122] In this embodiment, an electrical signal is to be introduced via a peripheral nerve stimulator connected to the proximal electrode connector 316 and propagated to the electrode cap 318 on the distal tip of the catheter 302 with an internal conductive wire 314. The electrode cap 318 provides transmission to a distal tip of a cannula 304. The catheter body 302 acts as an insulator for the rest of the cannula 304. Therefore, transmission of a signal with a single connection may be supplied via a distal tip of the cannula 304, the electrode cap 318 or singly via the electrode cap 318 by retracting the cannula 304 proximal of the electrode cap 318. Optionally, the outer surface of the electrode cap 318 may be insulated with an insulated material. In this embodiment, when an electrical signal is applied to the outer surface of the electrode cap 318 does not transmit an electrically signal as it is insulated.

40 [0123] A proximal hub 320 of the cannula 304 is further configured to accept a tip of a standard syringe (not shown). The proximal hub 320 includes a connector 322 for releasably coupling cannula hub 320 to the catheter hub 306. The catheter hub 306 is further configured to accept a connector (not shown) on an end of the connecting tube 112. The connecting tube 112 is coupled to an infusion pump on the opposite end (FIG. 1, 110). A frictional region 324, e.g., at

least a partially coarse region, is optionally added to a proximal portion of the catheter 302. The frictional region 324 is configured to aid in sealing an insertion site in the tissue, minimize leakage of contrast and/or pharmacological agent, and minimize movement of the catheter 302.

5 [0124] A distal portion of the catheter 302 includes an echogenic region 323 including echogenic material to aid with ultrasound visualization of a distal tip of the catheter 302. The echogenic material may include metallic flakes, reflective flakes derived from titanium, stainless steel, copper or other similarly inert metals or alloys that reflect the sound waves generated by the ultrasound probe. The catheter 302 includes a lumen 326 extending from a proximal end to a distal end. The hub 306 also includes a lumen 328 in communication with the lumen 326. Finally, the cannula hub 320 includes a lumen 330 extending from a proximal end to a distal end. The lumens 326, 328, and 330 are arranged to form one continuous lumen for administering a pharmacological agent or other medical device. The other medical device may include a balloon, active visualization device (imaging probe), surgical instrument, and the like.

10 [0125] A reinforcement material 332, e.g., axial stays, metal and the like as known in the art, is added to a body of the catheter 302 to provide enhanced rigidity, thereby preventing bunching and kinking of the catheter 302. A plurality of reinforcement material 332 may be used. The catheter 302 may be configured with various rigidities along a longitudinal axis of the catheter, e.g., the proximal portion may be stiffer than the distal portion.

15 [0126] FIG. 4 illustrates an enlarged view of a distal section of the conduction apparatus according to yet another embodiment of the invention.

[0127] Referring to FIG. 4, a distal tip of the apparatus is generally referred to as reference number 400. The rest of the apparatus (not shown) is similar to the catheter described in FIGS. 3A-3C and will not be described further. In this embodiment, the distal tip of the catheter 302 includes a retractable flap 402. The distal port of the catheter is patent while the introducing cannula 304 is inserted through the lumen of the catheter 302, but the retractable flap 402 is configured to deploy once the cannula 302 is withdrawn; that is, retractable flap 402 is configured to move from a closed position to an open position as shown. In a closed position and when the catheter is in use, only the side port 312 is utilized to deliver pharmacological agent.

20 [0128] FIG. 5 illustrates an enlarged view of a distal section of the conduction apparatus according to yet another embodiment of the invention.

[0129] Referring to FIG. 5, a distal tip of the apparatus is generally referred to as reference number 500. The rest of the apparatus (not shown) is similar to the catheter described in FIGS. 3A-3C and will not be described further. In this embodiment, the distal tip of the catheter 302 includes a plurality of retractable flaps 502 that are configured in an open position and closed position by movement of a cannula 304. More specifically, the distal port of the catheter is patent while the introducing cannula 304 is inserted through the lumen of the catheter 302, but the retractable flap 502 is configured to deploy once the cannula 304 is withdrawn; that is, retractable flap 502 is configured to move from an open position to a closed position. In a closed position and when the catheter is in use, only the side port 312 is utilized to deliver pharmacological agent.

25 [0130] FIG. 6A illustrates a perspective view of the continuous anesthesia nerve conduction apparatus according to another embodiment of the invention. FIG. 6B illustrates an enlarged view of a distal section of the continuous anesthesia nerve conduction apparatus according to FIG. 6A in various configurations.

[0131] Referring to FIGS. 6A-6B, a continuous anesthesia nerve conduction apparatus is generally depicted with reference to number 600. The apparatus 600 is similar to the apparatus described with reference to FIG. 3A-3C except for the distal portion of the reinforced catheter 602. The distal portion of the reinforced catheter 602 with a pre-formed shape, controllable shape or resilient shape. In one embodiment, when a cannula 604 is inserted through the lumen of the reinforced catheter 602, the distal tip of the catheter is straightened by the cannula 604, but when the cannula 604 is withdrawn, the distal tip takes its pre-formed shape. The shape may be an "L" shape as noted with reference to element 606, "U" shape as noted with reference to element 608, or curved as in 610. The proximal electrode connector 612 is positioned on the side of the proximal catheter hub 614 so that the direction of the pre-formed distal tip of the catheter is corresponding with the electrode connector 612. Alternatively, the distal end portion of the catheter 602 may be controllable with a wire system (not shown) to various geometries, e.g., "L" shape, "U" shape, or curved shape. The various geometries allow the distal portion of the catheter to be closer to a desired nerve or nerve bundle thus permitting a better distribution on anesthetic solution while keeping more of the catheter in close proximity to the nerve(s).

30 [0132] Catheters as described herein may be constructed, in whole or in part, utilizing a variety of degradable materials, polymeric materials, synthetic or natural, and combinations thereof. Furthermore, the catheters may be composed such that the portion of the catheter that enters and remains in the patient is degradable, but the portion that remains substantially outside of the patient is not degradable. Furthermore, a break point may exist between the two materials. The break point may be configured to facilitate breaking.

35 [0133] In some embodiments, the catheters may be composed of multiple components that are mixed as a blend, such as a plasticized system, and/or as a microphase immiscible system. If suitable reactive groups are introduced into the formed catheters, what is commonly known as a thermoset, or chemically cross-linked system can be generated under appropriate curing conditions. The formed catheters can also be composed in the form of a laminate or a fibrous

reinforced composite. Of course, the properties of the selected composition, e.g., molecular weight, glass transition temperature(s), crystallinity, and/or the extent of cross-linking will dictate the desired properties of the catheters. The catheters may also be coated with a variety of therapeutic agents such as pain, antibacterial, antimicrobial or anti-inflammatory coatings, drug coatings, and the like. The catheters may also include silver nanoparticles, for example the catheter may be impregnated with silver nanoparticles, to provide antibacterial properties.

[0134] FIG. 15A illustrates an embodiment of a catheter tip. FIG. 15B illustrates another embodiment of a catheter tip;

[0135] Referring to FIGS. 15A-B, it is shown that embodiments of catheters may be used with ports as described in U.S. Patent No. 7,004,923, which incorporated in its entirety by reference, may be used. The catheter is generally described herein and in this embodiment includes a distal portion as shown via reference number 1550. The distal portion 1550 includes an outer tube 1552. A plurality of fluid ports 1556 are provided within the tube 1552, preferably throughout the entire circumference thereof. The portion of tube 1552 that includes the ports 1556 defines the infusion section of catheter 1550. An access for the cannula is provided within the distal tip 1558 of the tube 1552.

[0136] The tube 1552 may be formed from any of a variety of suitable materials, giving due consideration to the goals of non-reactivity to anatomical systems, such as nylon, polyimide, Teflon, biodegradable materials previously discussed and other materials known to those skilled in the art, giving due consideration to the goals of non-reactivity to anatomical systems, flexibility, light-weight, strength, smoothness, and safety. In a preferred configuration, the tube 1552 is preferably a 20 gauge catheter tube, having inside and outside diameters of 0.019 inches and 0.031 inches, respectively. The ports 1556 of tube 1552 are preferably about 0.015 inches in diameter and provided at equally spaced axial positions along the tube 1552. The holes 1556 are preferably arranged so that every hole is angularly displaced about 120° relative to the longitudinal axis of the tube 1552, from the angular location of the previous hole. Other angular displacements are possible, e.g., in a range from about 5° to about 180° relative to the longitudinal axis of the tube.

[0137] The axial separation between adjacent ports 1556 is preferably within the range from about 0.1 inches to 0.3 inches, and more preferably about 3/16 inch. Also, the infusion section can have any desirable length but is preferably about 0.5 to 20 inches long, and more preferably about 10 inches long. This configuration results in a thorough, uniform delivery of fluid throughout a generally linear segment of the wound area. Of course, the ports 1556 may be provided in any of a variety of alternative arrangements. In addition, each port 1556 or only a portion of the ports may be surrounded with a marker to permit visualization, e.g., radiopaque, echogenic, and combinations of the same.

[0138] FIG. 15B illustrates a catheter which is generally described herein and in this embodiment includes a distal portion as shown via reference number 1550. This embodiment is better suited for relatively high flow rate delivery of fluid to a region within an anatomical system. Catheter 1550 includes a tube 1552 having a plurality of ports 1556 of increasing size. In particular, the more distal ports are larger in diameter than the more proximal ports. The position of the ports 1556 on the tube 1552 defines the length of the infusion section of the catheter 1550. The infusion section can have any desired length. The proximal end of catheter 1550 is connected to a fluid supply, and a guide wire and/or guide wire lumen may also be provided for aiding in the insertion of catheter 1550 into the anatomy. Marking lines 1561 and markers 1561 may surround a port 1556 to permit visualization, e.g., radiopaque, echogenic, and combinations of the same.

[0139] As discussed above, for high or low pressure fluid delivery, ports nearer to the distal end of a catheter tube generally have increased flow resistance compared to ports nearer to the proximal end of the tube. Also, the fluid flowing through the more distal holes experiences a greater pressure drop. Consequently, there is generally a greater flow rate of fluid through the more proximal holes, resulting in non-uniform fluid delivery. In contrast, catheter 1550 advantageously provides substantially uniform fluid delivery through substantially all of the ports 1556, under relatively high flow rate conditions. This is because the larger size of the more distal holes compensates for their increased flow resistance and pressure drop. In other words, since the more distal holes are larger than the more proximal holes, there is a greater flow rate through the more distal holes than there would be if they were the same size as the more proximal holes. Advantageously, the holes 1556 are provided in a gradually increasing size which results in substantially uniform fluid delivery. In addition, the ports 1556 may be sized so that they combine to form a flow-restricting orifice.

[0140] FIG. 16 illustrates an embodiment of a single handed catheter advancing device.

[0141] Referring to FIG. 16, the invention is a single handed catheter advancing device is generally depicted as reference number 400. The single handed device 400 allows a catheter to be advanced into a patient single handed. This device is not limited to only catheters described herein, but may be used with conventional needle over the catheter configurations. The device 400 includes a body 428 having free revolving rollers 424. The free revolving rollers 424 can be operated single handedly by the operator by placing the thumb of the operator on the free revolving rollers 424 and turning the rollers 424 which can insert or remove the catheter 402 depending upon the direction the rollers 424 are being turned. The catheter 402 is inserted through the catheter insertion opening 420 which is located at the end of the body 428. The free revolving rollers 424 advance the catheter 402 into the needle 404. The free revolving rollers 424 may include rubber grippers on the roller 424. The rubber grippers can be made of any suitable material, including but not limited to nylon, rubber, teflon, polyamide, polyfilline, other polymers and the like, or combinations thereof. The body 428 is also connected to a luer 405, such as a swivel male luer. The luer 405 can be connected to a needle hub 421,

which is also connected to the needle 404 either permanently or temporarily. For example, the luer 405 may contain threads that may engage with threads on the needle hub 421. The needle hub 421 can disconnect from the luer 405. In addition, the luer 405 may be an integral portion of the body 428.

5 [0142] The device operates to advance the catheter 402 into the needle 404 with one hand, while leaving the other hand of the operator free to perform other tasks, such as attach and operate a nerve stimulator or use an ultrasound to locate a nerve bundle. The operator introduces the needle 404 to the patient. The single handed device 400 may be connected as the operator introduces the needle 404 to the patient, or it may be attached at a later time. Once the needle 404 is in place, a catheter 402 may be introduced into the hollow needle 404. The device 400 contains channel 429, which directs the catheter 402 introduced to the device through the opening 420 through the luer 405, into the needle hub 421 and eventually into the needle 404. The operator can control the advancement of the catheter 402 using the rollers 424 on the body 428. Once the catheter 402 is in place, the operator may remove the needle 404 and device 400 in a single motion by sliding the needle 402 attached to the device 400 over the catheter 402. Alternatively, the operator may remove the needle 402 and device 400 in two steps by first disconnecting the device 400 from the needle 404 at the needle hub 421, then removing the needle 404 from the patient, while leaving the catheter 402 in place. The catheter 402 may then be joined to an apparatus, such as an infusion pump.

10 [0143] FIG. 17A illustrates a single handed catheter advancing device according to another embodiment. FIG. 17B illustrates a perspective view of a single handed catheter advancing device illustrated in FIG. 17A. FIG. 17C illustrates a perspective view of a single handed catheter advancing device illustrated in FIG. 17A with a catheter;

15 [0144] As illustrated in FIGS. 17A-17C, the device is generally depicted as reference number 500. The device 500 includes a catheter insertion opening 520 located adjacent to one of the free revolving rollers 524 of the body 528 and used to advance the catheter 502 through a luer 505 and into a needle or cannula. A handle 530 may be permanently or temporarily attached to the body 528 using any suitable means. The handle 530 may be ergonomical and made of any suitable material. Furthermore, the handle 530 may include indents for fingers - in particular it may include a groove to receive a portion of the thumb of the user. The handle 530 may be tapered, may vary in length, and may vary in diameter or size. In an alternative embodiment, a catheter insertion opening 520 may be located anywhere on the body of the single handed catheter. By way of example, the catheter insertion opening 520 may be located near the end of the handle 530, which is similar to the configuration of FIG. 16.

20 [0145] The body 528 is shown with the free revolving rollers 524 and is adjacent to the catheter insertion opening 520, which is located on the body 528 adjacent to the free revolving rollers 524. Luer 505 may be used to attach the device 500 to a needle, through the needle hub 521.

25 [0146] In one embodiment, the catheter 502 is advanced through the catheter insertion opening 520 of the body 528, which is adjacent to one of the free revolving rollers 524. The cannula or needle 504 is attached to the device 500 through the luer 505, which is connected to the needle hub 521. The catheter advances through the luer 505, through the needle hub 521, and into the needle 504.

30 [0147] FIG. 18 illustrates an operational systematic view of the single handed catheter advancing device 500 as illustrated in FIG. 17C. The device 500 includes a needle 504 which remains external to the patient. The sheath 504 is inserted through the needle hub 521 and the needle 504. The needle hub 521 is connected to the device 500 through a luer 505.

35 [0148] Nerve(s) 511 lying in deep to tissue below the exterior surface of the patient are targeted to receive a pharmacological agent. A subcutaneous distal portion of the needle 508 is shown positioned in close proximity to the targeted nerve(s) 511, e.g., nerves of the brachial plexus. A nerve stimulator (not shown) may be used to stimulate the nerve(s) 511. A nerve stimulator conducting wire 577 is electrically coupled between a nerve stimulator (not shown) and needle 504 to provide the requisite single to the needle 504. Once the needle is in place, the catheter 502 may be advanced through the needle. The needle may be removed and the hub 521 disconnected from the luer 505.

40 [0149] Next, an infusion pump may be filled with a pharmacological agent, e.g., medication, and the pump is connected to the apparatus. The pump can include ON-Q® C-bloc- Continuous Nerve Block System by I-Flow Corporation, PainPump 1, PainPump 2, PainPump 2 BlockAid by Stryker Corporation, and GoPump® or GoBlock® by Symbios and may be any of the embodiments previously explained and described with reference to FIGS. 7-14. Additionally, previously discussed catheter embodiments may also be used with this system.

45 [0150] The devices of FIGS. 15-18 allow a user to single handedly advance and retract a catheter to a desired location, e.g., nerve location. Thereby, the user may use the other free hand to aid with visualization. These devices may be used with conventional catheter-through-needle systems.

50 [0151] FIG. 19A illustrates an embodiment of a solid introducer. FIG. 19B illustrates the solid introducer of FIG. 19A in a catheter.

55 [0152] Referring to FIGS. 19A-19B, the solid introducer catheter system is generally depicted as reference number 600. The system includes a solid introducer 604. The solid introducer 604 may be used with the catheter 602 or other catheters described herein. The solid introducer 604 fits within the catheter 602. The catheter 602 may be a reinforced catheter and may include at least one or a plurality of ports 607 near the distal tip of the catheter 602. Ports as described

in FIGS. 15A-15B may also be used.

[0153] On the proximal end of the catheter 602 is a catheter hub 621. The solid introducer 604 may also include an optional curved tip 603 which may be used as a cutting surface to insert the solid introducer catheter system 600 into the patient. The solid introducer 604 may include an optional stimulator connection site 609 wherein a stimulator (not shown) may be connected through the solid introducer 604. The optional stimulator connection site 609, when inserted into the catheter 602 may rest on the catheter hub 621 which controls the depth of insertion of the solid introducer 604 through the catheter 602 such that the distal tip 603 of the solid introducer 604 protrudes from the tip of the catheter 602. Furthermore, the stimulator connection site 609 is adjustable along the length of the solid introducer 604. Additionally, a needle hub 605 may be used by the operator to pull the solid introducer 604 from the patient once the catheter 602 is in place. Once the solid introducer 604 has been removed from the catheter 602, the catheter hub 621 may be used to connect the catheter 602 to the remaining system or other device.

[0154] FIG. 20 illustrates another embodiment of the present invention, which is a hollow introducer catheter system 700. In this system, the introducer 704 is hollow. The hollow introducer 704 is advantageous because it allows a guide wire 734 to sit within the introducer 704 which sits inside of the catheter 702. The catheter 702 may be a tightly wound wire coil through the majority of the body of the catheter 702, but near the distal tip of the catheter 702 becomes a loosely wound wire which will allow for flexibility. The distal end of the catheter 702 may also include at least one or a plurality of ports 707. The introducer hub 705 rests upon the catheter hub 721, which controls the depth of the introducer 704 within the catheter 702. Once the introducer 704 has been removed, the catheter hub 721 may be used to connect the catheter 702 to the remaining system or other device.

[0155] FIG. 21 illustrates an embodiment of a guide wire.

[0156] Referring to FIG. 21, the guide wire 734 may be used with catheters as described herein. In one embodiment, the guide wire 734 is helpful for positioning the catheter 702 and stimulating the nerve bundle in the patient. Optionally, the guide wire 734 may be equipped with a flexible preformed tip 736 which allows for directional advancement of the catheter. The flexible preformed tip may be straightened out to pass through a needle or catheter, but will return to its preformed shape once it has exited the needle or catheter. In some embodiments, the position of the catheter follows the preformed shape of the guide wire once the guide wire is withdrawn. Near the guide wire hub 721, there is a directional tab 738 which corresponds to the direction and location of a flexible tip 736 on the guide wire 734. A stimulator (not shown) may also be attached to the directional tab 738. The guide wire 734 may be used either in the hollow introducer 704 or in the catheter 702.

[0157] FIG. 22A illustrates another embodiment of a hollow introducer in a catheter with a sleeve. FIG. 22B illustrates another embodiment of a guide wire in a catheter with a sleeve.

[0158] Referring to FIGS. 22A and 22B, a sleeve 740 used in the catheter system 700 which allows for the reinsertion of an introducer 704 into the catheter 702 for repositioning of the catheter 702. That is, the sleeve will prevent tears in an external or internal surface of a catheter 702 upon reinsertion or repositioning of the catheter 702 when a cannula is required to reposition the catheter by advancing through tissue.

[0159] FIG. 23 illustrates an embodiment of the continuous anesthesia nerve conduction apparatus. The apparatus is generally depicted as reference number 2200. The apparatus 2200 includes an introducer 2204, which may be a solid introducer or a hollow introducer, configured to fit within a catheter 2202 with at least one port 2214. An insert 2219 abuts and engages between the introducer end 2207 and the catheter hub 2206. The introducer 2204 slides into the catheter 2202, through the catheter hub 2206 and through the center of the insert 2219. The insert 2219 is configured, such that the user may access and connect a nerve stimulation device to the exposed segment of the introducer 2204 allowing for the introducer 2204 to become a stimlatable needle. The insert 2219 may contain threads on either or both sides that engage with the introducer end 2207 and/or the catheter hub 2206.

[0160] The catheter 2202 may include markings as described herein, e.g., markings as described with reference to FIGS. 28A-28B. Moreover, the catheter 2202 may include a pre-formed resilient distal portion configured to position the distal portion at least partially around a nerve. The pre-formed resilient distal portion may be configured to minimize dislodgment of at the catheter 2202 from a treatment situs. The catheter 2202 may be configured to fixedly bend from a first position to a second position with application of curved guidewire and curvature relative to a longitudinal axis of the catheter 2202 the curvature may be in a range from about 1 degree to about 180 degrees, more preferably the curvature is a range from about 80 degrees to about 110 degrees. The catheter 2202 may configured as described in FIGS. 6A-6B or any embodiment described herein like with any other catheter described herein.

[0161] FIG.24 is a view of the insert 2219. The insert 2219 contains openings 2223 which allows the introducer to fit through the insert 2219. A portion of the insert 2223 may contain threads to engage with an exterior thread on the introducer 2207 which may hold the introducer 2207 in place during use. Alternatively, the insert 2219 may be a slip fit, such that once the introducer 2207 is in place, it fits snugly within the insert 2219. In another embodiment, the insert 2219 contains threads on the end that abuts the introducer end, and engages with threads on a portion of the introducer. In another embodiment, the insert 2219 contains threads on the end that abuts the catheter hub, which engages with threads on the catheter hub. In another embodiment, the insert 2219 contains threads on both ends. Once the catheter

is in place, the user may connect a nerve stimulation device to the exposed segment of the introducer shaft to convert the introducer into a stimulating needle for nerve localization.

5 [0162] Some embodiments of the insert 2219 contain at least one optional opening 2220. The opening 2220 may be any shape or size and may provide access to the introducer through the insert 2219. In other embodiments, the insert 2219 is a solid piece, without any openings 2220. In still other embodiments, the insert is tapered on one end such that the tapered end comes into contact with the introducer. The insert 2219 may be connected to a stimulator in order to stimulate the introducer. In still other embodiments, the insert 2219 may be ergonomical and may include indents for fingers - in particular it may include a groove to receive a portion of the thumb of the user. The insert 2219 may assist the user to disconnect the introducer from the catheter with the use of only one hand.

10 [0163] The insert 2219 may vary in length and may be made of any suitable materials. In some embodiments, the insert 2219 is made from a polymeric material. In other embodiments, the insert 2219 is made of an electrically conductive material. In other embodiments, the insert 2219 may be made of a polymeric material, which has been impregnated with an electrically conductive material.

15 [0164] FIG. 25A illustrates a perspective view of a continuous anesthesia nerve conduction apparatus according to another embodiment of the invention in first orientation. FIG. 25B illustrates the continuous anesthesia nerve conduction apparatus of FIG. 25A in a second orientation. FIG. 25C illustrates a guidewire according to another embodiment of the invention. FIG. 25D illustrates a guidewire according to another embodiment of the invention.

20 [0165] Referring to FIGS. 25A-25D, a continuous anesthesia nerve conduction apparatus is generally depicted as reference number 2500. The apparatus 2500 includes an integrated guidewire with a needle to allow for single handed deployment of guidewire by advancing the tab on the needle hub. Also this apparatus reduces procedural steps by not having to detach the syringe before advancing guidewire. The apparatus 2500 includes a reinforced catheter 2502 over a cannula 2504 with an integrated hub 2506. The catheter 2502 includes a port 2503. The hub includes a guidewire advancer 2508 configured to a move a guidewire 2510 from a first position to a second position with activation from a user, e.g., a thumb of a user, as shown by the arrow. The catheter 2502 can slide off the cannula 2504. The guidewire 2510 may be configured with an angled geometry 2512 at a distal tip to aid bending a distal portion of the catheter 2502 around or partially around a nerve. The cannula 2504 includes a lumen extend from proximal portion to a distal portion to allow fluid transfer. The catheter and/or cannula may include markings as described here to aid with location of each to a desired treatment situs. The guidewire may also be a steerable guidewire as known in the art.

25 [0166] FIG. 26A illustrates a perspective view of a continuous anesthesia nerve conduction apparatus according to another embodiment of the invention. FIG. 26B illustrates a cross-sectional view of the continuous anesthesia nerve conduction apparatus according to FIG. 26A.

30 [0167] Referring to FIGS. 26A-26B, a continuous anesthesia nerve conduction apparatus is generally depicted with reference to number 2600. In this embodiment, an integrated catheter with a dual lumen is illustrated. The apparatus 2600 includes a catheter 2602 having a first lumen 2604 and a second lumen 2606. The first lumen 2604 and second lumen 2606 merge to one lumen 2607 at a distal portion of the catheter. The first lumen 2604 extends from a proximal portion to a distal portion of a hub 2608. A port 2610 is in fluid communication with the first lumen 2604. The hub 2608 includes a guidewire advancer 2508 configured to a move a guidewire 2510 from a first position to a second position with activation from a user, e.g., a thumb of a user.

35 [0168] The guidewire 2510 may be configured with an angled geometry 2512 at a distal tip to aid bending a distal portion of the catheter 2502 around or partially around a nerve. The catheter 2602 in this embodiment is configured to puncture a skin directly and has functional characteristics as a cannula. The catheter may include a side port or plurality of ports. The catheter may include markings as described here to aid with location of each to a desired treatment situs. Optionally, an additional removable sleeve may utilized over the catheter 2602.

40 [0169] FIG. 27A illustrates a perspective view of a continuous anesthesia nerve conduction apparatus according to another embodiment of the invention. FIG. 27B illustrates a cross-sectional view of the continuous anesthesia nerve conduction apparatus according to FIG. 27A.

45 [0170] Referring to FIGS. 27A-27B, a continuous anesthesia nerve conduction apparatus is generally depicted with reference to number 2700. In this embodiment, an integrated catheter with a dual lumen is illustrated. The apparatus 2700 includes a catheter 2702 having a first lumen 2704 and a second lumen 2706. The first lumen 2704 and second lumen 2706 extend from a proximal portion to a distal portion of a hub 2708. A port 2710 is in fluid communication with the first lumen 2704. The hub 2708 includes a guidewire advancer 2508 configured to a move a guidewire 2510 from a first position to a second position with activation from a user, e.g., a thumb of a user.

50 [0171] The guidewire 2510 may be configured with an angled geometry 2512 at a distal tip to aid bending a distal portion of the catheter 2502 around or partially around a nerve. The catheter 2702 in this embodiment is configured to puncture a skin directly and has functional characteristics as a cannula. The catheter may include a side port or plurality of ports. The catheter may include markings as described here to aid with location of each to a desired treatment situs. Optionally, an additional removable sleeve may utilized over the catheter 2702.

55 [0172] FIG. 28A illustrates a distal end of a continuous anesthesia nerve conduction apparatus according to another

embodiment of the invention. FIG. 28B illustrates a distal end of a continuous anesthesia nerve conduction apparatus according to another embodiment of the invention.

5 [0173] Referring to FIGS. 28A, a distal portion 2800 of a catheter 2802 includes a first port 2804, second port 2806 and third port 2808. The first port 2804 and second port 2806 are oriented on opposite side of the catheter 2802. A plurality of markings 2810, 2812, 2814, 2816, 2818, 2820, 2822 are configured to aid in the angular orientation and longitudinal orientation of the catheter and ports 2804, 2806, and 2808. Any combination of markings may be used, e.g., more or less may be utilized. The markings may have different geometric configurations to also aid with orientations. The markings may include an echogenic material, radiopaque material, combination of the same and the like. In addition, the catheter may include markings as described with reference to U.S. Patent Application Publication 2012/0059308, which is hereby incorporated by reference as if fully set forth herein.

10 [0174] Referring to FIGS. 28B, the distal portion 2800 includes two ports, 2804 and 2808 and at least one marking 2810 positioned immediately proximally adjacent to the port 2804. The marking 2804 is utilized to is configured to aid in port location and utilized to position the port 2804 to a desired treatment situs, e.g., a nerve.

15 [0175] Described next is a method of administering a pharmacological agent in accordance with another embodiment of the invention. This embodiment will be described with reference to the continuous anesthesia nerve conduction apparatus described in FIGS. 3A-3C. However, any apparatus described herein may be used with this procedure.

20 [0176] Advantageously, the method of administering the pharmacological agent in accordance with the invention does not need to occur in a fully sterile environment and is much faster than the traditional methods of administering a pharmacological agent. In addition, the operator can perform the method by herself without requiring assistance from another person.

25 [0177] Initially, preparatory steps are performed prior to performing a procedure. These steps include applying non-sterile gloves on both hands and opening sterile packaging of the apparatus 302. Next, a cannula 304 is positioned through the lumen 326 of the catheter 302, and the cannula 304 is secured to the hub of the catheter 302 via locking mechanism 322. In an embodiment, each of the items used during the procedure are provided in a sterile kit. In another embodiment, each item used during the procedure is preassembled in the kit.

[0178] A syringe (not shown) is connected to the cannula hub 320. A distal portion of the catheter 302 is maintained in a sterile manner within its covering. The proximal portion of the catheter 302 and cannula 304 are exposed so that a standard syringe filled with a liquid solution is coupled to the hub 320.

30 [0179] Next, a patient is positioned according to the type and location of nerve(s) to be targeted as known in the art. The operative portion of the patient (insertion site) is prepped with an antiseptic solution. If a peripheral nerve stimulator is being used, the peripheral nerve stimulator is connected to the exposed proximal end of the apparatus via an electrode connector 316 on the proximal hub of the catheter 302. The necessary connection for the peripheral nerve stimulator to the patient is also performed and the nerve stimulator is activated for the appropriate setting as known in the art.

35 [0180] An ultrasound probe is held in the non-operative hand and positioned on the patient to obtain an image of the targeted nerve(s). Once the ultrasound probe is in position, the insertion site for the apparatus including a cannula 304 and catheter 302 (combined apparatus) can be ascertained and a skin wheal is raised to anesthetize the insertion site.

[0181] With the other hand (operative hand), the combined apparatus is slipped out of the sterile covering and inserted through the insertion site. The distal tip of the combined apparatus is then advanced towards the targeted nerve(s) under direct visualization via the ultrasound image.

40 [0182] If nerve stimulation is used, the distal tip of the combined apparatus is advanced towards the targeted nerve(s) until the appropriate muscle stimulation is obtained for confirmation that the distal tip of the apparatus is positioned in proximity to the targeted nerve(s). Once adjacent to the targeted nerve(s), the solution in the standard syringe that was previously attached to the proximal hub of the introducing cannula 304 is injected to hydro-dissect the tissue surrounding the targeted nerve(s). Real time ultrasound visualization is possible because the non-operative hand is simultaneously positioning the ultrasound probe to obtain a view of the targeted nerve(s) and while positioning the distal portion of the inserted apparatus with the operative hand.

45 [0183] Once the tissue surrounding the nerve(s) is expanded with the solution in the syringe, the proximal hub 306 of the catheter is released from the hub lock 322 on the proximal hub 320 of the introducing cannula 304 with the operative hand. The catheter 302 is then advanced with a finger of the operative hand while the introducing cannula 304 is withdrawn from the lumen of the catheter 302 with the operative hand, much like advancing an intravenous catheter off the needle and into a blood vessel. This is done simultaneously while maintaining an ultrasound image of the distal portion of the catheter 302 and the targeted nerve(s) with the non-operative hand manipulating/managing the ultrasound probe. If the catheter's distal tip is not able to extend into its pre-formed shape due to tissue obstruction, a guide wire can be positioned through the lumen of the cannula to aid the directional positioning of the catheter tip.

50 [0184] With the catheter 302 positioned adjacent to the targeted nerve(s), and the introducing cannula 304 withdrawn, another syringe with local anesthetic solution is connected to the proximal hub of the catheter that is exteriorized on the patient, and local anesthetic can be injected via the catheter alone, while again being visualized in real-time with the ultrasound imaging maintained by the non-operative hand. Once placement of the distal tip of the catheter 302 and local

anesthetic spread is confirmed by ultrasound imaging, the ultrasound probe and/or the peripheral nerve stimulator can be set aside.

[0185] The syringe can then be disconnected from the catheter 302, and the proximal hub 306 of the catheter 302 is secured to the patient's skin with adhesive tape applied to the hub and wings 308, 310. The hub can then be capped or connected to an infusion pump via a connecting tube. The externalized portion of the catheter 302 and hub 306 can be covered with a clear dressing to further minimize dislodgement, and maintain sterility.

[0186] These steps can be accomplished by one proficient in the arts in approximately the same time or less than it takes to perform a single-injection nerve block with a needle alone. The approximate time from positioning the patient (according to the type and location of nerve(s) to be targeted as known in the art) to securing and dressing the hub can take less than 10 minutes. In a preferred embodiment, the procedure takes less than 10 minutes to perform.

[0187] Another embodiment of the invention includes a kit for the delivery of a fluid to a nerve bundle of a patient. The kit includes a pump, a length of tubing securable to said pump, an introducer, and a catheter. The introducer is configured to fit within the catheter. The pump, tubing, catheter and introducer are provided together as a kit. Other items may also be provided in the kit, e.g., guidewire and stimulator.

[0188] Without intending to limit the scope of the invention, the following examples illustrate how various embodiments of the invention may be made and/or used.

EXAMPLES

[0189] The following examples illustrate the time to insert a catheter, secure the catheter and dress the patient using the method described herein (Example 1) as compared to the traditional method (Example 2).

[0190] Table 1 illustrates a timed comparison between the steps and method duration of Example 1, the method described herein, and steps and method duration of Example 2, the traditional method. Each step is described in detail below. All time listed in Table 1 are approximate.

Example 1:

[0191] Examples 1 and 2 are directed towards a medical procedure for inserting a catheter for delivering a pharmacological agent to a nerve bundle in the neck of a patient. The method in each example generally included three broad steps: Step 1 - Setup; Step 2 - Procedure; and Step 3 - Securing Catheter. Example 1 was conducted with an apparatus according to embodiments of the invention. Example 2 was conducted with a needle over catheter apparatus and the procedure to insert the needle over catheter apparatus.

[0192] **Step 1:** (Setup): The operator opened a single sterile device package, which included supplies such as a Terumo® 2.5 inch 18 gauge Surflo® I.V. Catheter. FIG. 29 illustrates items used in the procedure of Example 1. With reference to FIG. 29, these items include (starting from the top left of FIG. 29 and proceeding counter-clockwise) tubing (white package partially open) 2902, 5cc syringe 2904 containing medication to sedate the patient, 3cc syringe 2906 with a 25 gauge 1.5 inch needle attached to the syringe which contained Lidocaine, a 20cc syringe 2908 with Ropivacaine, another 20cc syringe 2910 which contained Ropivacaine with an angiocath attached to the syringe within a cover (the angiocath is an 18 gauge 2.5 inch needle within an 18 gauge 2.5 inch catheter, where the needle extends just past the tip of the catheter), a package of Betadine swabs 2912, securing strips 2914, a tacky substance 2916 to attach the securing strips and a clear dressing 2918. The operator put on non-sterile gloves and filled the syringes. The local area on the patient where the angiocath was inserted was prepared by swabbing the area with Betadine as illustrated in FIG. 30. The operator put the ultrasound probe in the vicinity of the nerve bundle. The ultrasound probe contained a small amount of gel applied to the tip of the probe. The probe was used to monitor the area surrounding the nerve bundle throughout the procedure.

[0193] **Step 2:** (Procedure): The operator obtained an ultrasound image of the area, and then anesthetized the skin and subcutaneous area with the 3cc syringe filled with Lidocaine as illustrated in FIG. 31. The 1.5 inch needle attached to the 3cc syringe extended to the nerve bundle, which was monitored using the ultrasound image. The 1.5 inch needle was withdrawn from the patient and set aside. The operator picked up the 20cc syringe of Ropivacaine with the angiocath attached and slipped off the housing. The operator inserted the angiocath into the patient and directed the angiocath to the nerve bundle using the needle of the angiocath until the angiocath was near the nerve bundle, which was monitored using an ultrasound image as illustrated in FIG. 32. Once the operator reached the nerve bundle, the operator hydro-dissected the tissue surrounding the nerve bundle using the Ropivacaine in the 20cc syringe while monitoring the tissue surrounding the nerve bundle with an ultrasound image as illustrated in FIG. 33. The operator put their finger on the tip of the catheter hub and removed the needle while the catheter was advanced. The needle, which was connected to the syringe, was removed from the catheter with one hand, while the position of the catheter was monitored using an ultrasound image as illustrated in FIG. 34. The operator set down the empty 20cc syringe, which was still attached to the needle, and picked up the second 20cc syringe which contained Ropivacaine and connected the syringe to the

EP 2 680 920 B1

catheter hub and injected about 20cc of Ropivacaine into the patient through the catheter as illustrated in FIG. 35. This injection of Ropivacaine verified the catheter position and effectiveness. The operator removed and set aside the second syringe from the catheter hub and removed and set aside the ultrasound probe. The operator attached the tubing to the catheter hub as illustrated in FIG. 36.

[0194] Step 3: (Securing the Catheter): The catheter and tubing were secured to the patient with adhesive strips with the tacky substance and clear dressing was applied as illustrated in FIG. 37.

Comparative Example 2:

[0195] Step 1: (Setup): The operator opened the package that contained an Arrow StimuCath® Continuous Nerve Block Procedure Kit. The kit was double wrapped. The operator put on sterile gloves and filled the syringes. The operator setup the ultrasound probe and filled the sterile sleeve with gel. The operator placed the probe into the sterile sleeve and secured the sleeve to the ultrasound probe. The operator attached the PNS. The operator draped the patient and prepared a large area surrounding the injection site.

[0196] Step 2: (Procedure): The operator obtained an ultrasound image of the area, and anesthetized the skin and subcutaneous. The operator inserted the needle into the patent and hydrodissected the surrounding tissue. The operator then blindly advanced the catheter through the needle with both hands, while trying to maintain stimulation of the nerve and advance the catheter. As the needle was backed out from its position in the patient, the catheter was advanced. Once the operator believed the catheter was in place, the operator took another scan of the area with the ultrasound probe, which was put aside in order to advance the catheter. Before the operator injected a pharmacological agent through the catheter, the operator attached a connector hub to the catheter. After the hub was attached, the tubing was attached.

[0197] Step 3: (Securing Catheter): Excess length of the catheter was coiled and the catheter was secured to the patient using adhesive strips. Clear dressing was applied to the patient.

Table 1: Comparison Table of Example 1 and Comparison Example 2

Device	Terumo® 2.5 inch 18 gauge Surflo® I.V. Catheter	Arrow StimuCath® Continuous Nerve Block Procedural Kit
Step 1 Setup:		
Opening of packaging and supplies	00:05 Single sterile device in package	01:00 Double wrapped sterile kit
Gloving	00:10 Non-sterile gloves	01:00 Sterile gloves
Filling Syringes	00:30 Drawing up syringes	00:30 Drawing up syringes from kit
US Probe setup	00:05 Apply non-sterile gel	02:30 Fill sterile sleeve with gel Place probe into sterile sleeve Secure sleeve to probe
Attach PNS	n/a	00:30
Prep and Drape	00:05 Betadine swabs - no draping	01:00 Wide sterile prep with sterile draping
Step 2 Procedure:		
Obtaining first US image	00:30	00:30
Anesthetize skin and SQ	00:15	00:15
Insertion of needle and catheter system	00:15	00:15
Hydrodissecting of surrounding tissue	00:30 - 02:00 (variable)	00:30 - 02:00 (variable)

(continued)

	Step 2 Procedure:		
5	Positioning catheter	00:05 Catheter advanced off of needle	01:00 - 10:00 (variable) Blind advancement of catheter through needle with both hands Trying to maintain stimulation while advancing catheter
10	Removal of needle	n/a Needle withdrawn when catheter was positioned	00:30 Needle is backed out while advancing catheter
	Rescan for image	n/a US image maintain at all times	00:30 Need to rescan since probe was put aside to advance catheter
15	Inject through catheter	00:30 Large bore with low resistance	01:00 Need to attach connector hub Long catheter with high resistance
20	Attach tubing to catheter	00:15 Tubing connected directly to catheter hub	00:30 Need to attach hub and connect tubing
	Step 3 Securing Catheter:		
25	Secure catheter and apply dressing	00:15 Adhesive strips and clear dressing	00:30 Coiling extra catheter length Adhesive strips and clear dressing
	Total time (minutes)	03:30 - 05:30	12:00 - 24:00

30 **[0198]** Important distinctions exist between Example 1 and Example 2. Notably, Example 1 is performed by a single clinician. Example 2 requires an assistant simply due to the fact that the operator, equipment and supplies must maintain sterility with the traditional method. Furthermore, the setup and method explained in Example 2 requires that all necessary equipment and supplies are handled in a sterile fashion. If any aspect of the method is accidentally contaminated, a sterile replacement for the equipment and supplies will be required, which frequently necessitates a new set up.

35 **[0199]** The steps illustrated in Example 1 are more precise and easily performed by an operator. Example 1 does not require draping or preparation of a large area on the patient, rather no draping is required and only a small portion of the patient is prepared. Furthermore, the ultrasound imager is maintained throughout the procedure in Example 1 as opposed to Example 2. The operator in Example 2 only regains the ultrasound image of the patient after the needle has been removed. Positioning the catheter as illustrated in Example 2 is highly variable with regard to time. It is rare that the catheter is in the correct position on the first attempt. More typically, the catheter and quite often the needle require repositioning which can take considerable time since real-time ultrasound imaging is not available to the operator. Furthermore, if the catheter is misplaced, then the operator may have to remove the catheter and start over with a new sterile kit.

45 **[0200]** Compared to the traditional method (Example 2), the method and device described herein using a catheter that allows for an internal introducer can result in as much as about a 70% to about 80% savings in time. This estimate is conservative and does not take into consideration the time to reposition the catheter and needle if required, which is likely using the traditional method.

50 **Claims**

1. A medical apparatus for administering a continuous flow or intermittent bolus of an anesthetic agent to facilitate a continuous or a prolonged nerve block, comprising:

- 55 a catheter (202) having a proximal end, a distal end, a lateral port arranged at a location proximal to the distal end, a pre-formed resilient portion on a distal portion of the catheter, and at least one lumen (226) extending from the proximal end to the distal end; and
- a stimulating cannula (204) having a hub, a proximal end, a distal end and a lumen extending from the proximal

end of the stimulating cannula to the distal end of the stimulating cannula, the stimulating cannula configured to be arranged in the at least one lumen of the catheter such that a distal end portion of the stimulating cannula extends past the distal end of the catheter, wherein the distal end of the stimulating cannula is open and configured to provide a pharmacological agent to a nerve (106), wherein the stimulating cannula is configured to provide electrical stimulation to the nerve when electrically coupled to a nerve stimulator, wherein the pre-formed resilient portion is configured to position the distal portion of the catheter at least partially around the nerve upon removal of the stimulating cannula from the lumen of the catheter, wherein the catheter and the stimulating cannula (204) are configured to be inserted into a patient simultaneously the stimulating cannula has tip including at least one of a sharp tip, a short beveled tip, and a Touhy tip configured to puncture skin of a patient upon insertion, and wherein the catheter is configured to remain in the patient when the stimulating cannula is removed from the catheter.

2. The medical apparatus of claim 1, wherein the catheter comprises a reinforced catheter (302).
3. The medical apparatus of claim 1, wherein the catheter comprises an embedded conductive element configured to be in electrical communication with at least a portion of the stimulating cannula (204).
4. The medical apparatus of claim 3, further comprising a hub (207) on the catheter comprising the embedded conductive element (314), wherein the embedded conductive element (314) is configured to be coupled to the nerve stimulator.
5. The medical apparatus of claim 1, further comprising a hub (206) on the catheter, the hub comprising a first tab (210) and a second tab (212) configured to be adhered to a patient, wherein the first tab and the second tab are arranged in a proximal portion of the catheter.
6. The medical apparatus of claim 1, wherein the lateral port comprises a plurality of lateral ports configured to provide a pharmacological agent to the nerve.
7. The medical apparatus of claim 1, further comprising a marking directly adjacent and spaced proximal the lateral port.
8. The medical apparatus of claim 1, wherein the pre-formed resilient portion is configured to minimize dislodgment of the catheter from a patient.
9. The medical apparatus of claim 1, wherein the pre-formed resilient portion is configured to position a distal portion of the catheter at least partially around the nerve upon removal of the stimulating cannula from the lumen of the catheter which comprises a curvature of the distal portion of the catheter relative to a longitudinal axis in a range from about 90 degrees to about 180 degrees.
10. The medical apparatus of claim 1, wherein a portion of the catheter comprises at least one marking comprising at least one of an echogenic material or radiopaque material.
11. The medical apparatus of claim 10, wherein the echogenic material comprises titanium, copper, metal, alloy or combinations thereof.
12. The medical apparatus of claim 1, further comprising:
 - a hub on a proximal portion of the catheter; and
 - an insert arranged proximal to the hub of the catheter.
13. The medical apparatus of claim 1, further comprising an active imaging element on a distal portion of the catheter.
14. A kit comprising the medical apparatus according to any of the foregoing claims and further comprising a portable pump.
15. The medical apparatus of claim 1, wherein a proximal portion of the catheter comprises a thickened or frictional segment configured to minimize leakage of the anesthetic agent, aid in sealing an insertion situs, or minimize movement of the catheter.

Patentansprüche

1. Medizinische Vorrichtung zum Verabreichen eines kontinuierlichen Stroms oder intermittierenden Bolus eines anästhetischen Wirkstoffs, um eine kontinuierliche oder länger andauernde Nervenblockade zu ermöglichen, umfassend:

einen Katheter (202) mit einem proximalen Ende, einem distalen Ende, einem an einer Stelle proximal zu dem distalen Ende angeordneten lateralen Port, einem vorgeformten elastischen Abschnitt an einem distalen Abschnitt des Katheters und mindestens einem Lumen (226), das sich von dem proximalen Ende zu dem distalen Ende erstreckt; und

eine Stimulationskanüle (204) mit einem Ansatz, einem proximalen Ende, einem distalen Ende und einem Lumen, das sich von dem proximalen Ende der Stimulationskanüle zu dem distalen Ende der Stimulationskanüle erstreckt, wobei die Stimulationskanüle dazu konfiguriert ist, in dem mindestens einen Lumen des Katheters angeordnet zu werden, sodass sich ein distaler Endabschnitt der Stimulationskanüle über das distale Ende des Katheters hinaus erstreckt, wobei das distale Ende der Stimulationskanüle offen ist und dazu konfiguriert ist, einem Nerv (106) einen pharmakologischen Wirkstoff bereitzustellen, wobei die Stimulationskanüle dazu konfiguriert ist, dem Nerv elektrische Stimulation bereitzustellen, wenn sie elektrisch an einen Nervenstimulator gekoppelt ist,

wobei der vorgeformte elastische Abschnitt dazu konfiguriert ist, den distalen Abschnitt des Katheters mindestens teilweise um den Nerv herum zu positionieren, wenn die Stimulationskanüle aus dem Lumen des Katheters entfernt wird,

wobei der Katheter und die Stimulationskanüle (204) dazu konfiguriert sind, gleichzeitig in einen Patienten eingeführt zu werden und die Stimulationskanüle eine Spitze aufweist, die mindestens eine von einer scharfen Spitze, einer kurzen abgeschrägten Spitze und einer Tuohy-Spitze umfasst und dazu konfiguriert ist, beim Einführen die Haut eines Patienten zu durchstechen, und

wobei der Katheter dazu konfiguriert ist, in dem Patienten zu verbleiben, wenn die Stimulationskanüle aus dem Katheter entfernt wird.

2. Medizinische Vorrichtung nach Anspruch 1, wobei der Katheter einen verstärkten Katheter (302) umfasst.

3. Medizinische Vorrichtung nach Anspruch 1, wobei der Katheter ein eingebettetes leitfähiges Element umfasst, das dazu konfiguriert ist, in elektrischer Verbindung mit mindestens einem Abschnitt der Stimulationskanüle (204) zu stehen.

4. Medizinische Vorrichtung nach Anspruch 3, weiter umfassend einen Ansatz (207) an dem das eingebettete leitfähige Element (314) umfassenden Katheter, wobei das eingebettete leitfähige Element (314) dazu konfiguriert ist, an den Nervenstimulator gekoppelt zu werden.

5. Medizinische Vorrichtung nach Anspruch 1, weiter umfassend einen Ansatz (206) an dem Katheter, wobei der Ansatz eine erste Lasche (210) und eine zweite Lasche (212) umfasst, die dazu konfiguriert sind, an einen Patienten geklebt zu werden, wobei die erste Lasche und die zweite Lasche in einem proximalen Abschnitt des Katheters angeordnet sind.

6. Medizinische Vorrichtung nach Anspruch 1, wobei der laterale Port eine Vielzahl von lateralen Ports umfasst, die dazu konfiguriert sind, dem Nerv einen pharmakologischen Wirkstoff bereitzustellen.

7. Medizinische Vorrichtung nach Anspruch 1, weiter umfassend eine Markierung direkt neben und proximal des lateralen Ports beabstandet.

8. Medizinische Vorrichtung nach Anspruch 1, wobei der vorgeformte elastische Abschnitt dazu konfiguriert ist, das Dislozieren des Katheters von einem Patienten zu minimieren.

9. Medizinische Vorrichtung nach Anspruch 1, wobei der vorgeformte elastische Abschnitt dazu konfiguriert ist, einen distalen Abschnitt des Katheters mindestens teilweise um den Nerv herum zu positionieren, wenn die Stimulationskanüle aus dem Lumen des Katheters, der eine Krümmung des distalen Abschnitts des Katheters relativ zu einem Längszugang in einem Bereich von ungefähr 90 Grad bis ungefähr 180 Grad umfasst, entfernt wird.

10. Medizinische Vorrichtung nach Anspruch 1, wobei ein Abschnitt des Katheters mindestens eine Markierung umfasst,

die ein echogenes Material und/oder ein röntgendichtes Material umfasst.

5 11. Medizinische Vorrichtung nach Anspruch 10, wobei das echogene Material Titan, Kupfer, Metall, eine Legierung oder Kombinationen davon umfasst.

12. Medizinische Vorrichtung nach Anspruch 1, die weiter Folgendes umfasst:

10 einen Ansatz an einem proximalen Abschnitt des Katheters; und
einen Einsatz, der proximal zu dem Ansatz des Katheters angeordnet ist.

13. Medizinische Vorrichtung nach Anspruch 1, weiter umfassend ein aktives Abbildungselement an einem distalen Abschnitt des Katheters.

14. Set, umfassend die medizinische Vorrichtung nach einem der vorangehenden Ansprüche und weiter umfassend eine tragbare Pumpe.

15 15. Medizinische Vorrichtung nach Anspruch 1, wobei ein proximaler Abschnitt des Katheters ein verdicktes oder Reibsegment umfasst, das dazu konfiguriert ist, das Auslaufen des anästhetischen Wirkstoffs zu minimieren, das Abdichten eines Einführungsorts zu unterstützen oder die Bewegung des Katheters zu minimieren.

Revendications

25 1. Appareil médical pour l'administration d'un flux continu ou de bolus intermittent d'un agent anesthésique pour faciliter un bloc nerveux continu ou prolongé, comprenant :

30 un cathéter (202) ayant une extrémité proximale, une extrémité distale, un orifice latéral disposé au niveau d'un emplacement proximal par rapport à l'extrémité distale, une partie résiliente préformée sur une partie distale du cathéter, et au moins une lumière (226) s'étendant de l'extrémité proximale à l'extrémité distale ; et
35 une canule de stimulation (204) ayant une garde, une extrémité proximale, une extrémité distale et une lumière s'étendant de l'extrémité proximale de la canule de stimulation à l'extrémité distale de la canule de stimulation, la canule de stimulation configurée pour être disposée dans ladite au moins une lumière du cathéter de sorte qu'une partie d'extrémité distale de la canule de stimulation se prolonge au-delà de l'extrémité distale du cathéter, dans lequel l'extrémité distale de la canule de stimulation est ouverte et configurée pour fournir un agent pharmacologique à un nerf (106), dans lequel la canule de stimulation est configurée pour fournir une stimulation électrique au nerf quand elle est couplée électriquement à un stimulateur de nerf,
40 dans lequel la partie résiliente préformée est configurée pour positionner la partie distale du cathéter au moins partiellement autour du nerf quand la canule de stimulation est retirée de la lumière du cathéter, dans lequel le cathéter et la canule de stimulation (204) sont configurés pour être insérés dans un patient simultanément, la canule de stimulation ayant une pointe incluant au moins une pointe parmi une pointe acérée, une pointe courte biseautée et une pointe Tuohy configurée pour perforer la peau d'un patient quand elle est insérée, et
45 dans lequel le cathéter est configuré pour rester dans le patient quand la canule de stimulation est retirée du cathéter.

2. Appareil médical de la revendication 1, dans lequel le cathéter comprend un cathéter renforcé (302).

3. Appareil médical de la revendication 1, dans lequel le cathéter comprend un élément conducteur incrusté configuré pour être en communication électrique avec au moins une partie de la canule de stimulation (204).

4. Appareil médical de la revendication 3, comprenant en outre une garde (207) sur le cathéter comprenant l'élément conducteur incrusté (314), dans lequel l'élément conducteur incrusté (314) est configuré pour être couplé au stimulateur de nerf.

5. Appareil médical de la revendication 1, comprenant en outre une garde (206) sur le cathéter, la garde comprenant une première languette (210) et une deuxième languette (212) configurées pour être collées sur un patient, dans lequel la première languette et la deuxième languette sont disposées dans une partie proximale du cathéter.

EP 2 680 920 B1

6. Appareil médical de la revendication 1, dans lequel l'orifice latéral comprend une pluralité d'orifices latéraux configurés pour fournir un agent pharmacologique au nerf.
- 5 7. Appareil médical de la revendication 1, comprenant en outre un repère directement adjacent à l'orifice latéral et espacé de manière proximale de celui-ci.
8. Appareil médical de la revendication 1, dans lequel la partie résiliente préformée est configurée pour minimiser le délogement du cathéter d'un patient.
- 10 9. Appareil médical de la revendication 1, dans lequel la partie résiliente préformée est configurée pour positionner une partie distale du cathéter au moins partiellement autour du nerf quand la canule de stimulation est retirée de la lumière du cathéter qui comprend une courbure de la partie distale du cathéter par rapport à un accès longitudinal dans un intervalle d'environ 90 degrés à environ 180 degrés.
- 15 10. Appareil médical de la revendication 1, dans lequel une partie du cathéter comprend au moins un repère comprenant au moins un matériau échogène et/ou un matériau radio-opaque.
11. Appareil médical de la revendication 10, dans lequel le matériau échogène comprend le titane, le cuivre, un métal, un alliage ou des combinaisons de ceux-ci.
- 20 12. Appareil médical de la revendication 1, comprenant en outre :
- une garde sur une partie proximale du cathéter ; et
- une pièce rapportée disposée de manière proximale par rapport à la garde du cathéter.
- 25 13. Appareil médical de la revendication 1, comprenant en outre un élément d'imagerie active sur une partie distale du cathéter.
- 30 14. Trousse comprenant l'appareil médical selon l'une quelconque des revendications précédentes et comprenant en outre une pompe portable.
- 35 15. Appareil médical de la revendication 1, dans lequel une partie proximale du cathéter comprend un segment épaissi ou à frottement configuré pour minimiser la fuite de l'agent anesthésique, faciliter l'étanchéisation d'un site d'insertion ou minimiser le mouvement du cathéter.

40

45

50

55

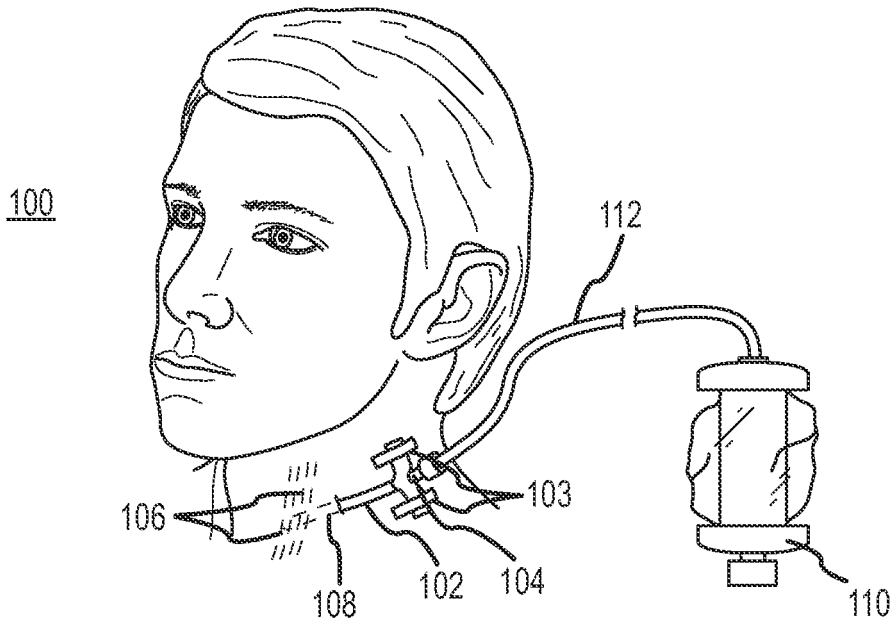

FIG. 1

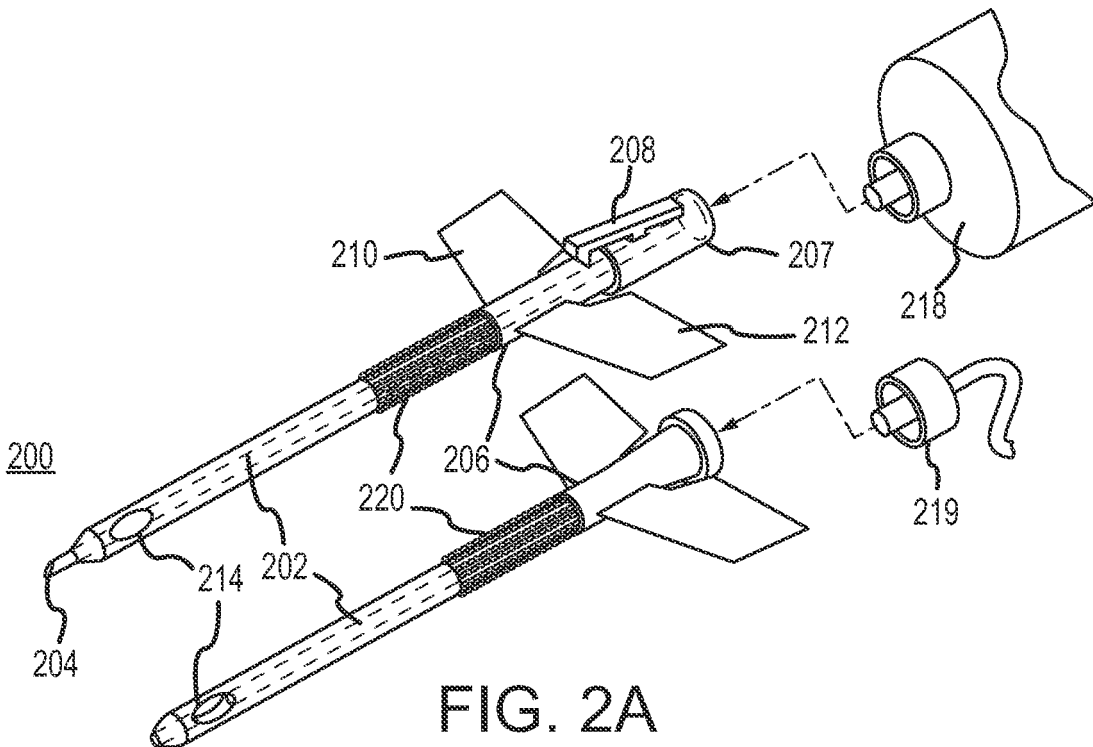

FIG. 2A

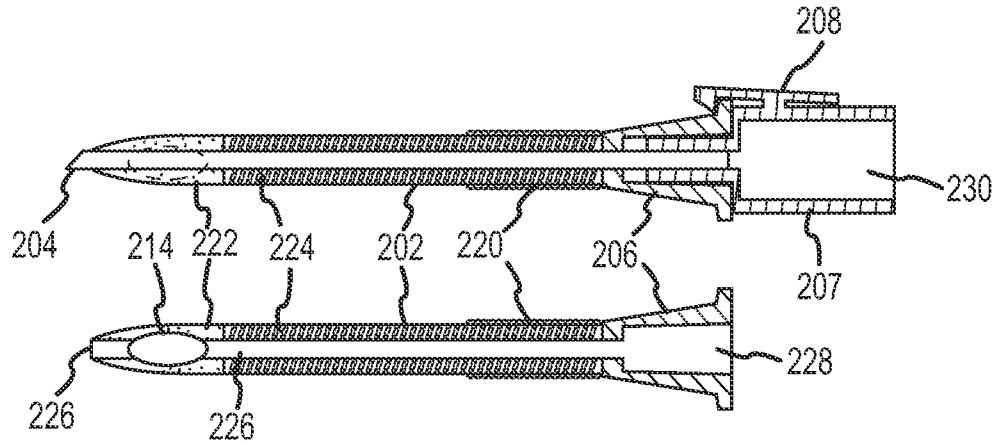

FIG. 2B

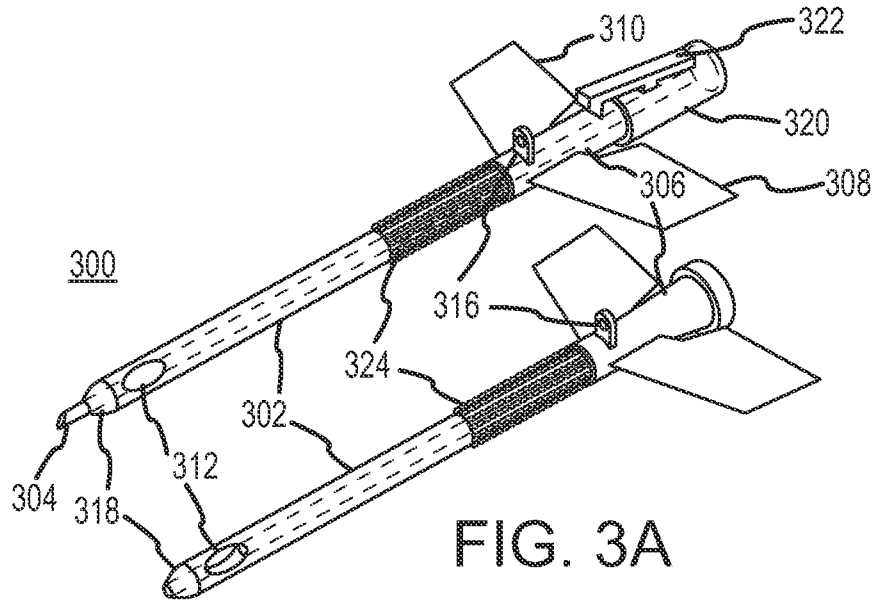

FIG. 3A

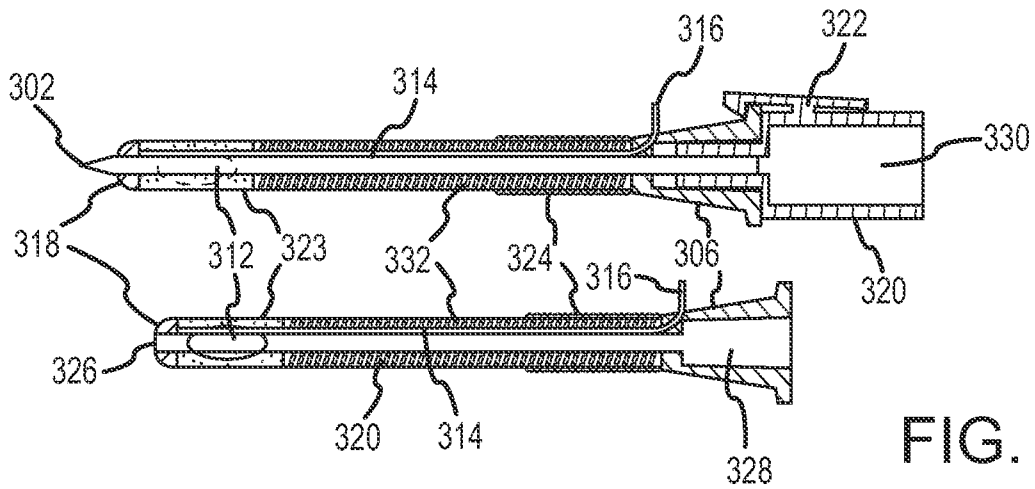

FIG. 3B

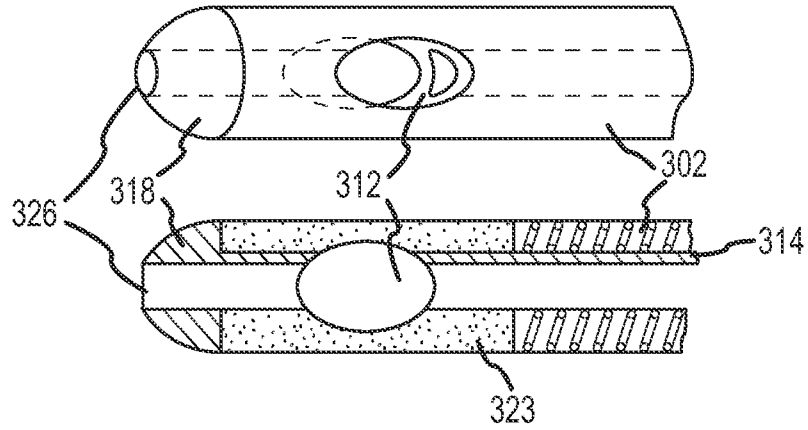

FIG. 3C

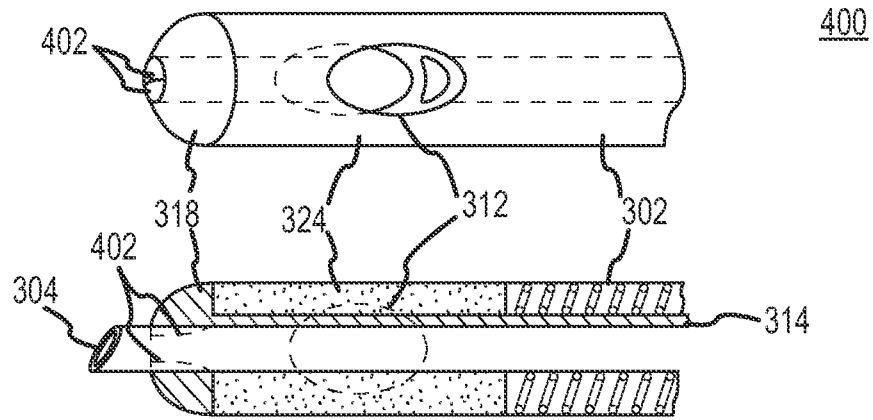

FIG. 4

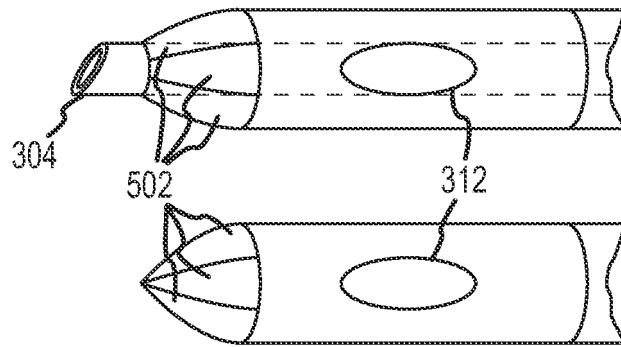

FIG. 5

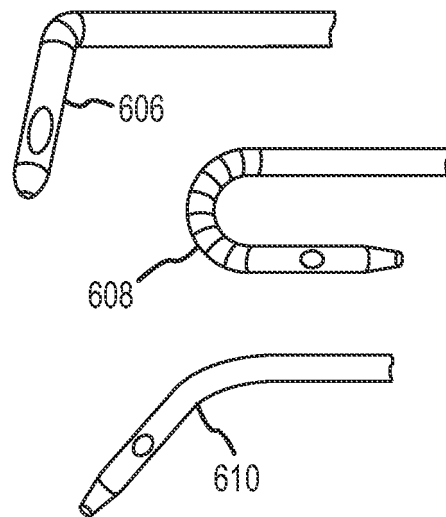
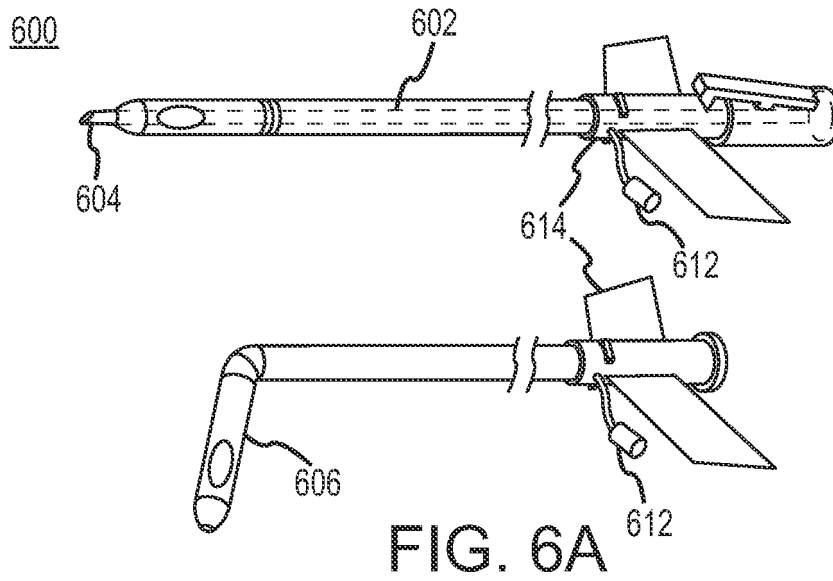

FIG. 6B

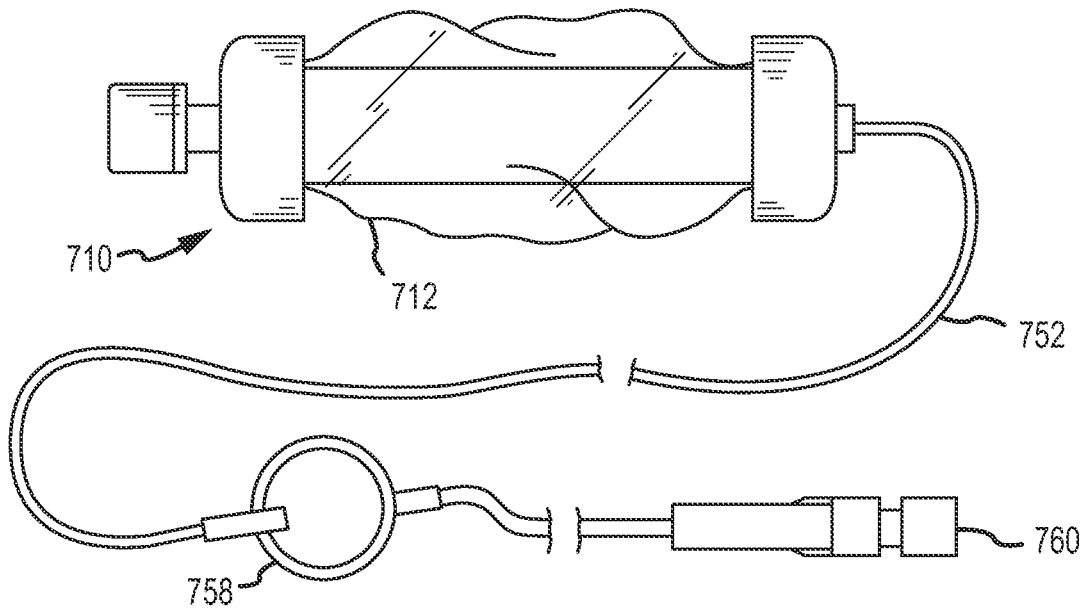

FIG. 7

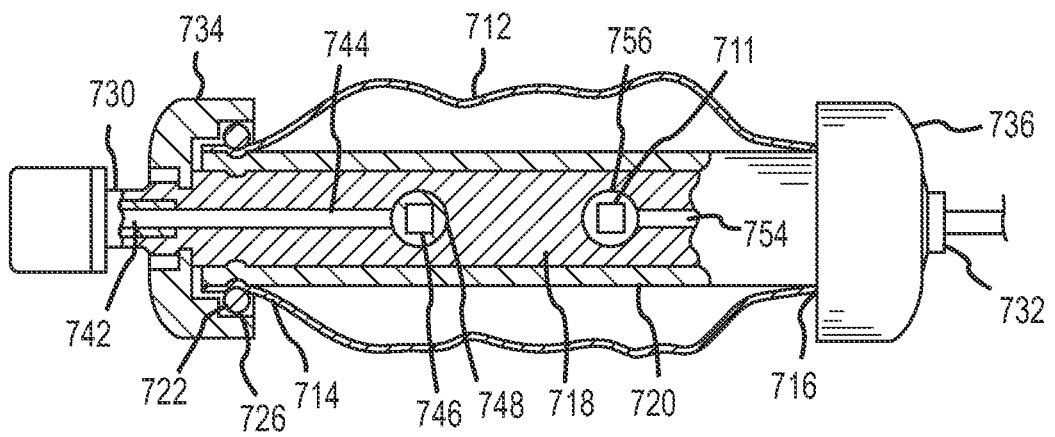

FIG. 8

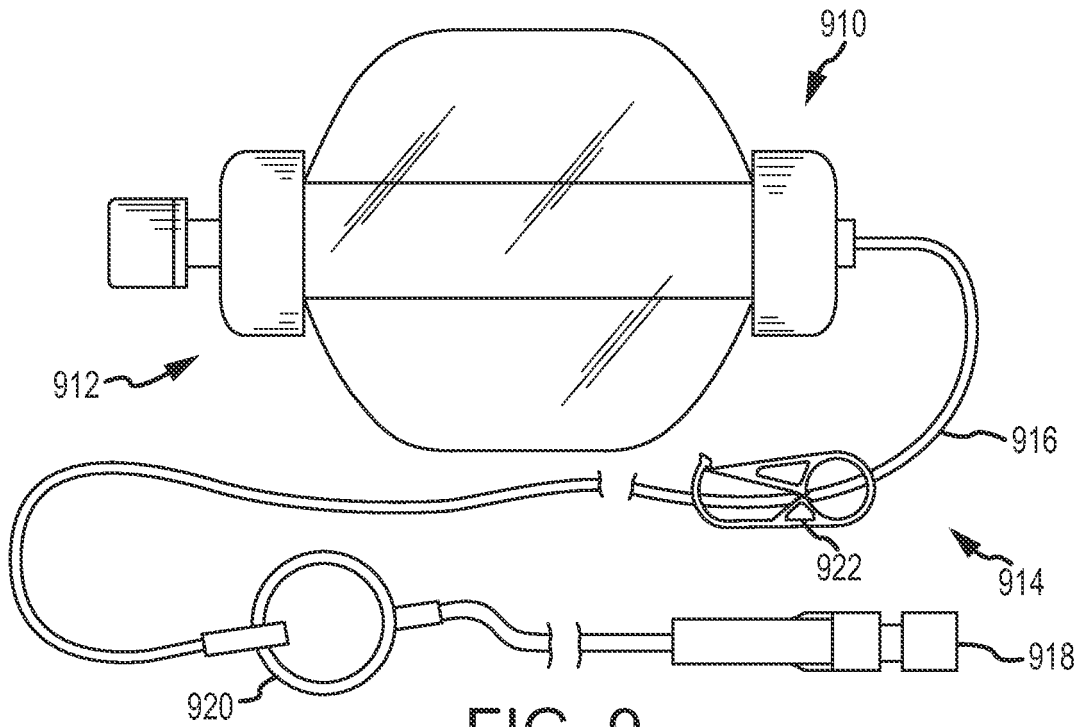

FIG. 9

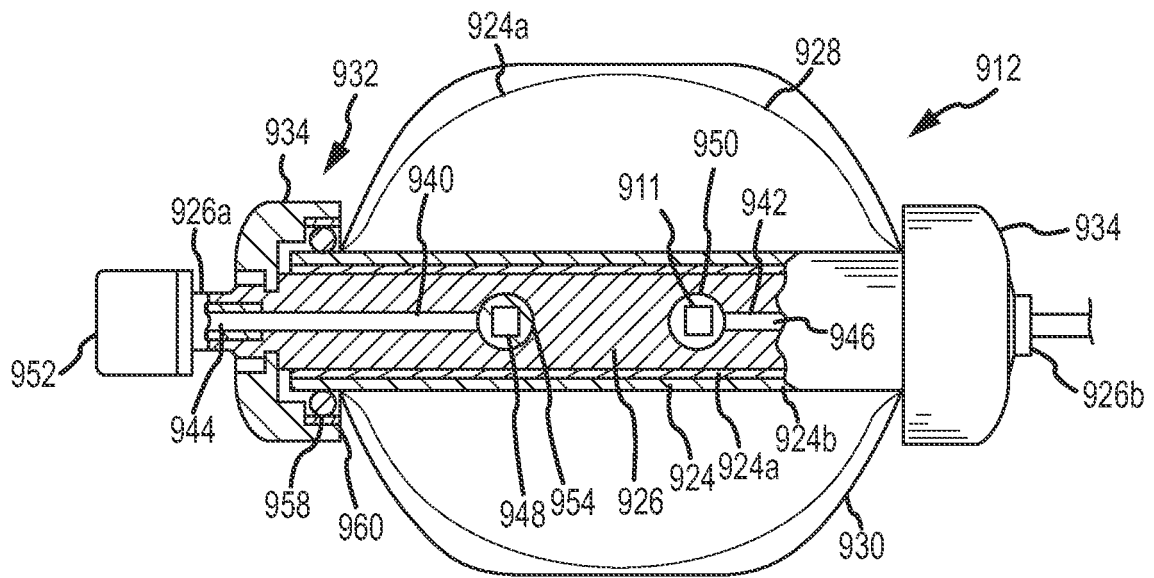

FIG. 10

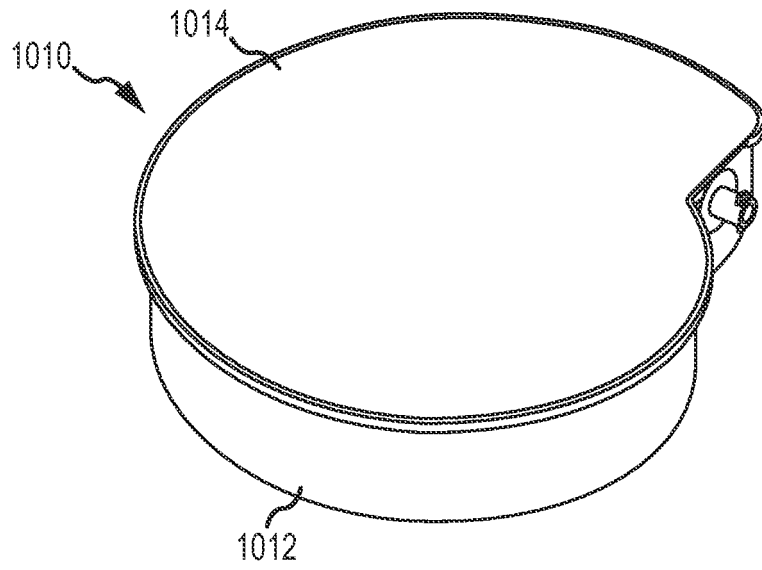

FIG. 11

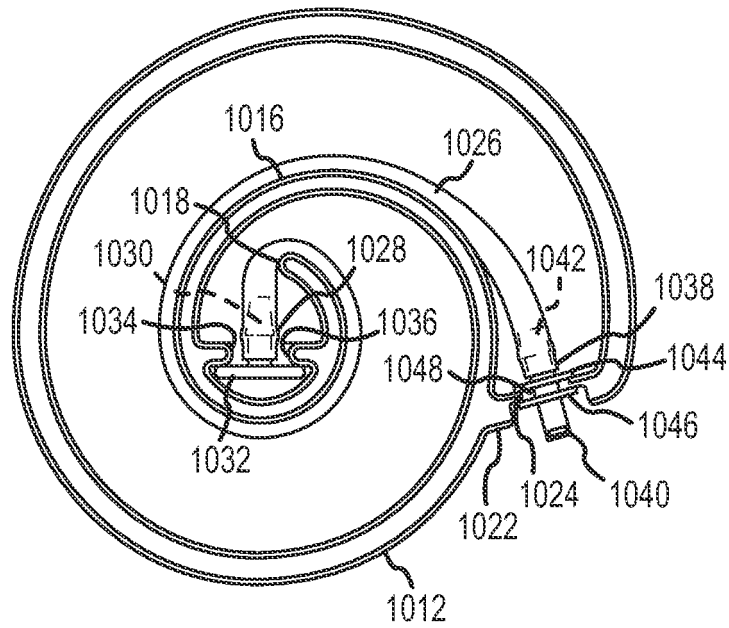

FIG. 12

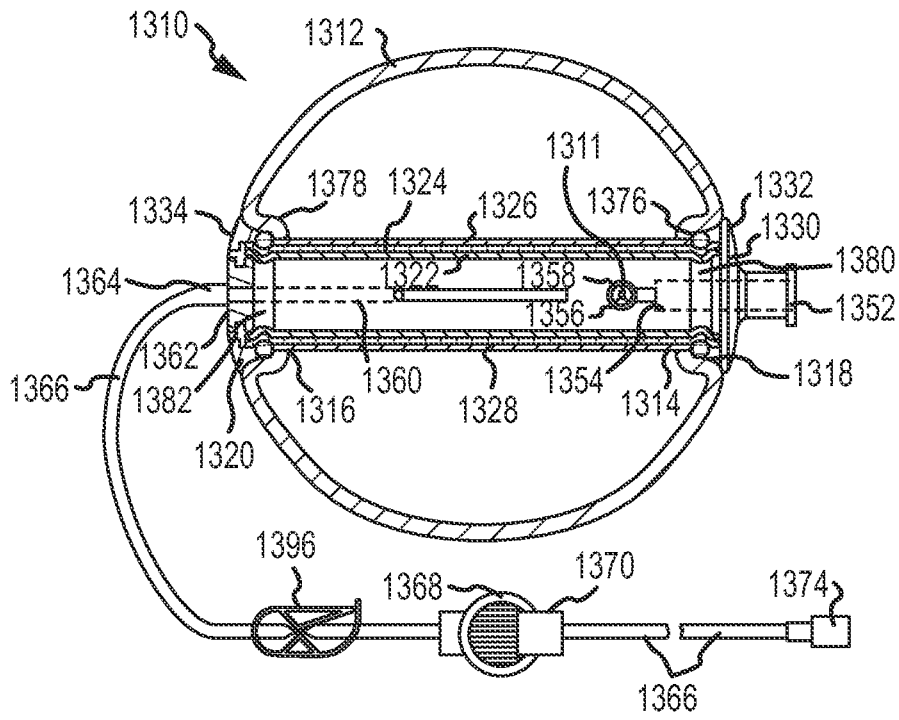

FIG. 13

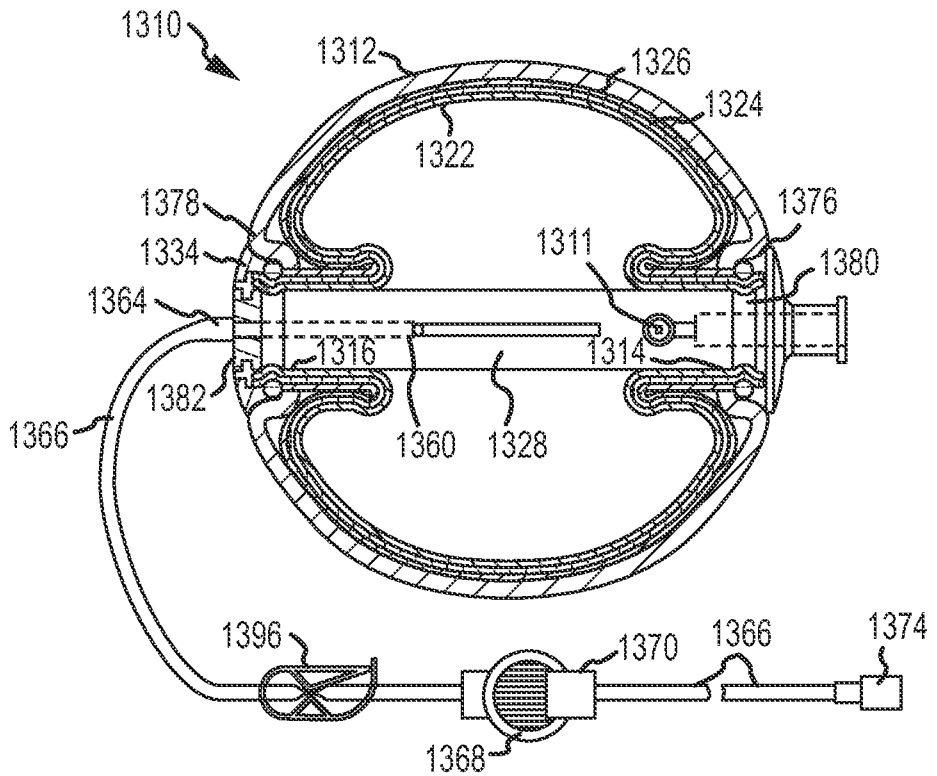

FIG. 14

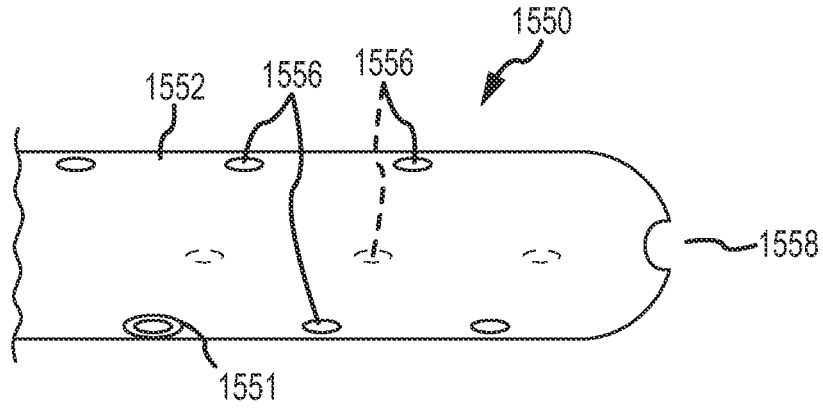

FIG. 15A

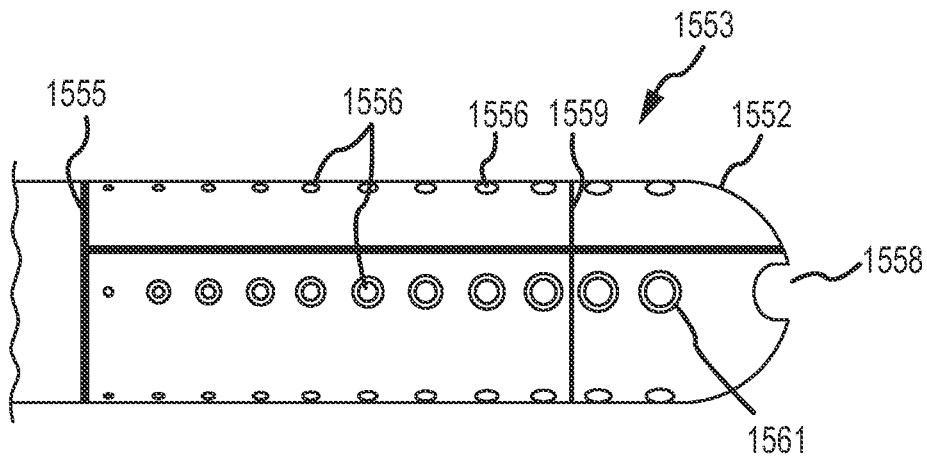

FIG. 15B

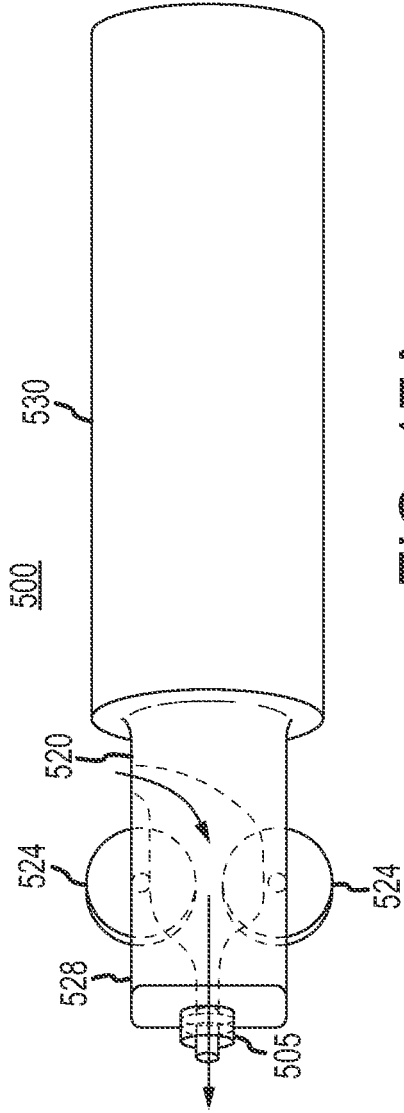

FIG. 17A

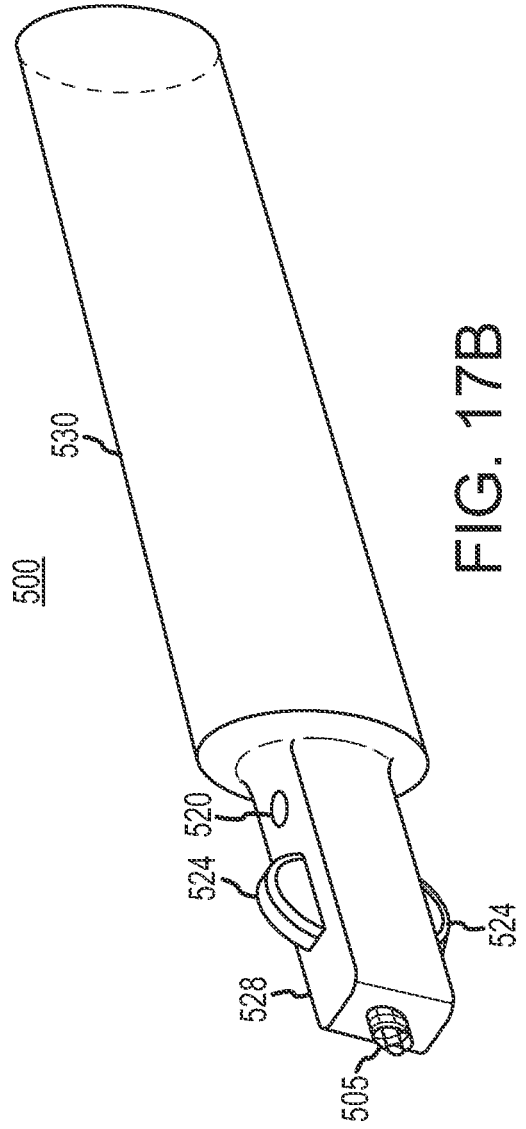

FIG. 17B

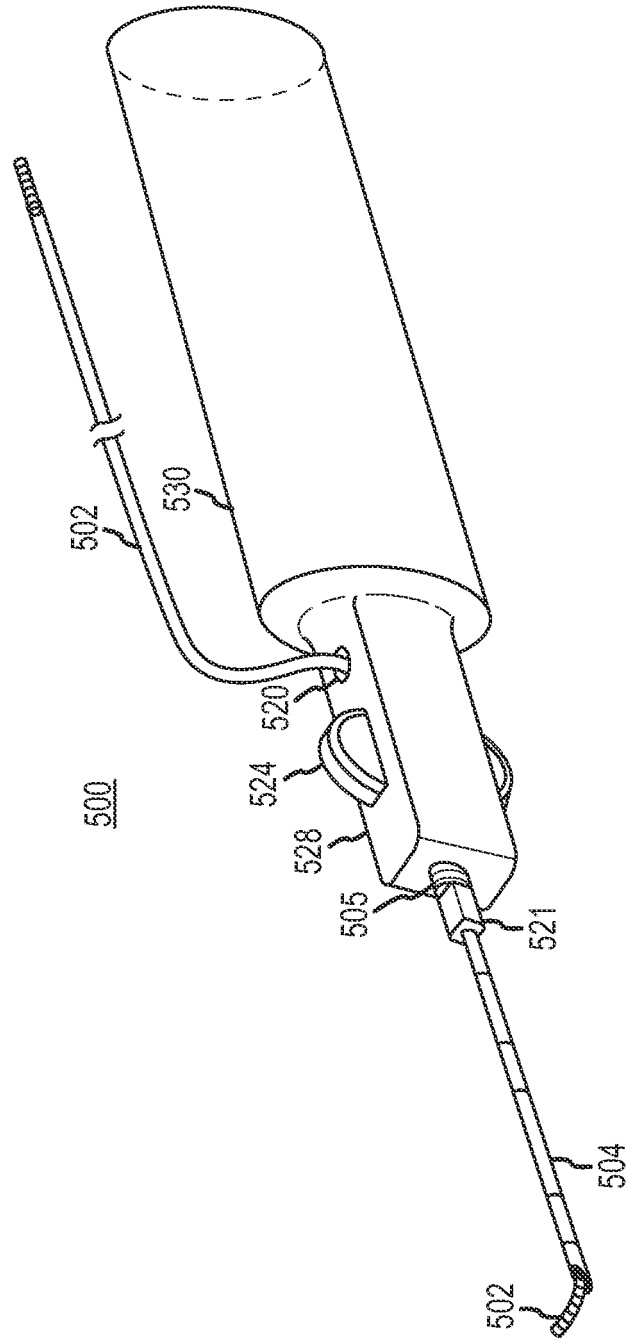

FIG. 17C

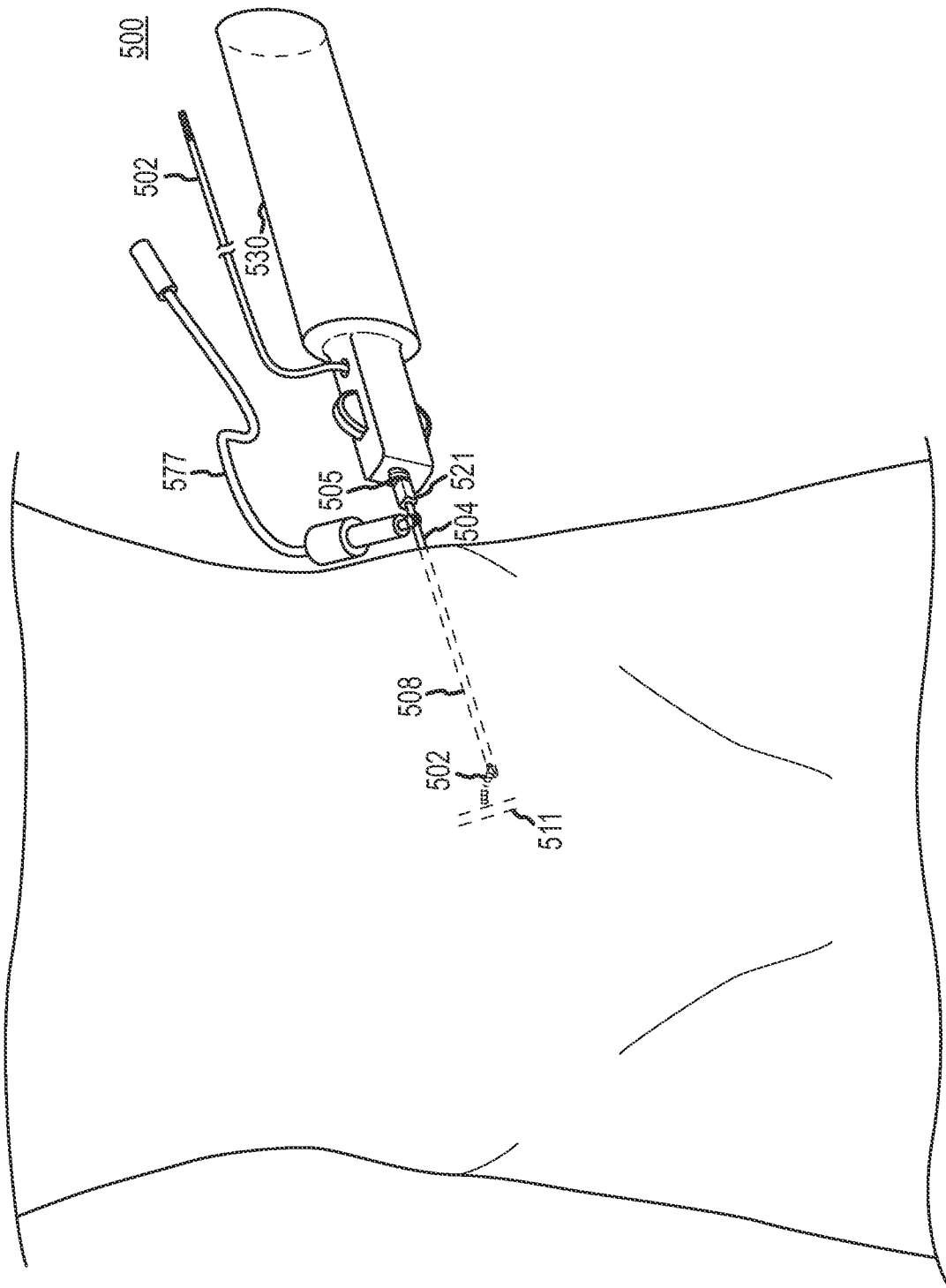

FIG. 18

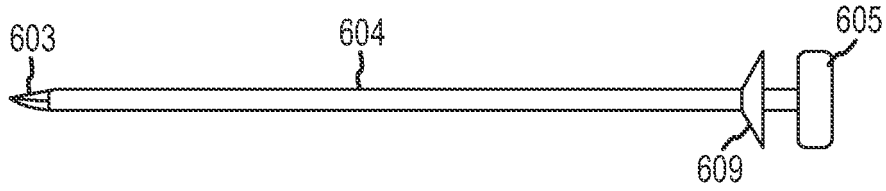

FIG. 19A

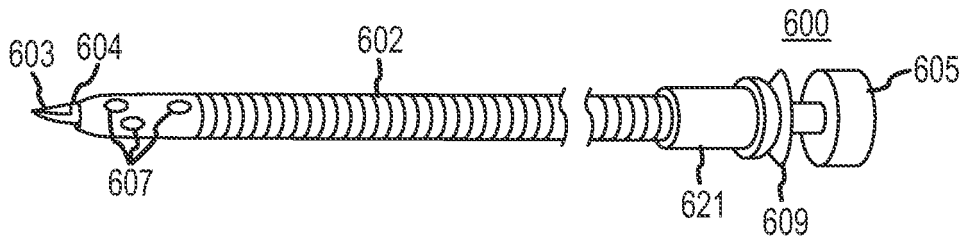

FIG. 19B

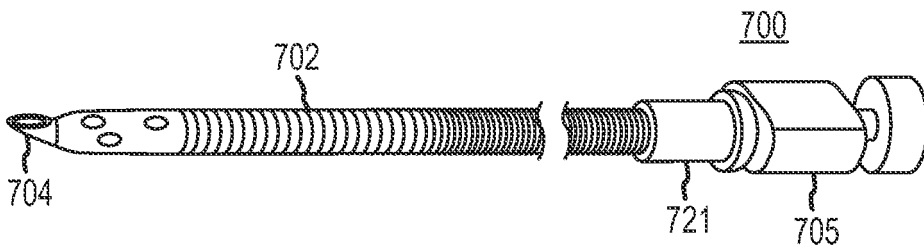

FIG. 20

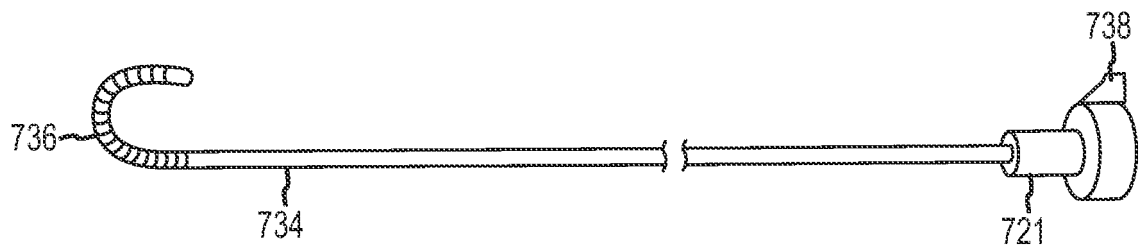

FIG. 21

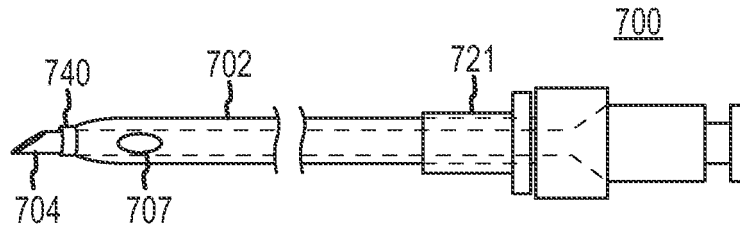

FIG. 22A

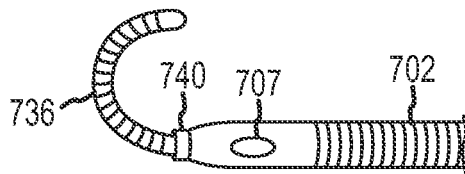

FIG. 22B

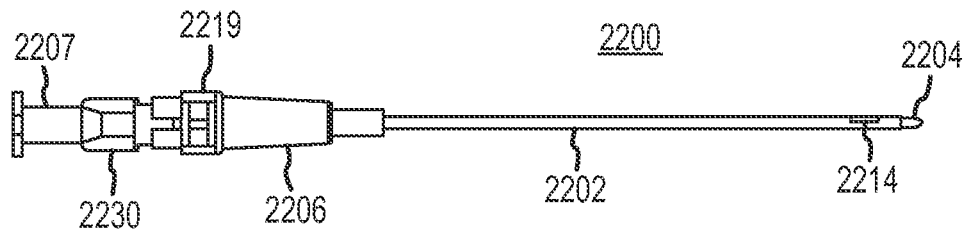

FIG. 23

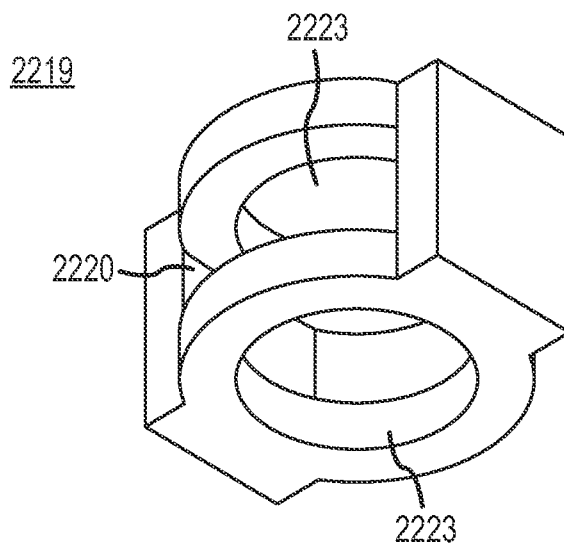

FIG. 24

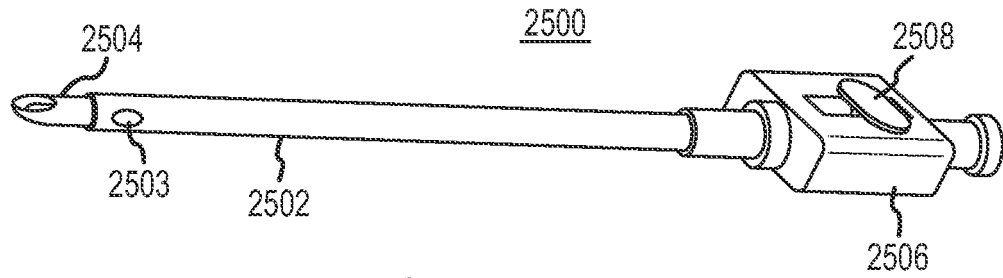

FIG. 25A

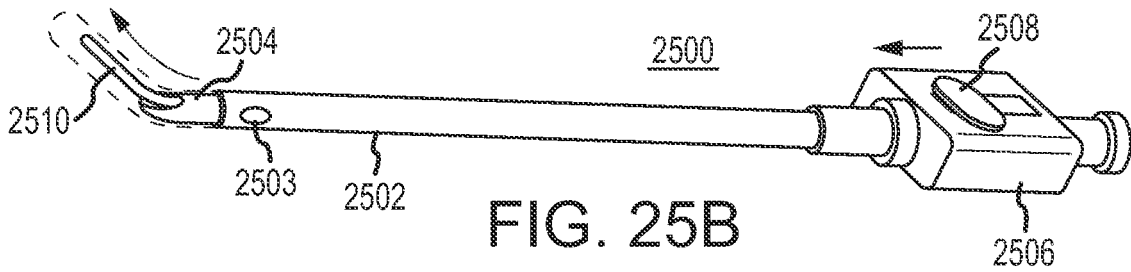

FIG. 25B



FIG. 25C



FIG. 25D

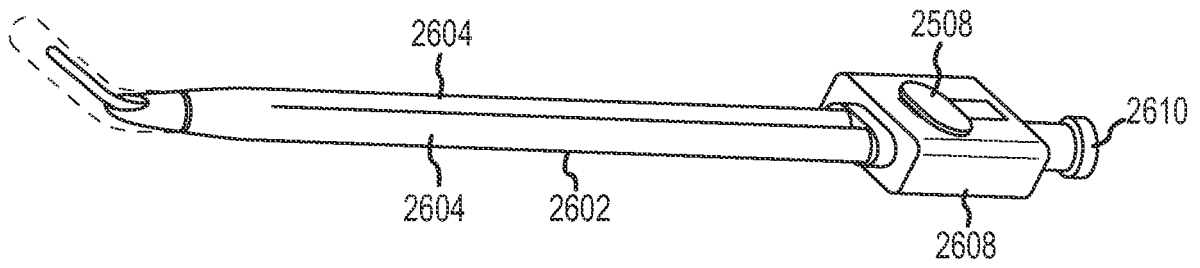

FIG. 26A

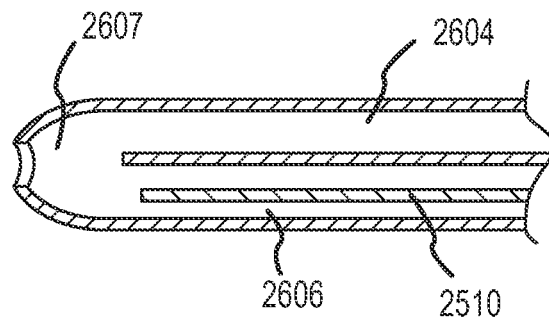

FIG. 26B

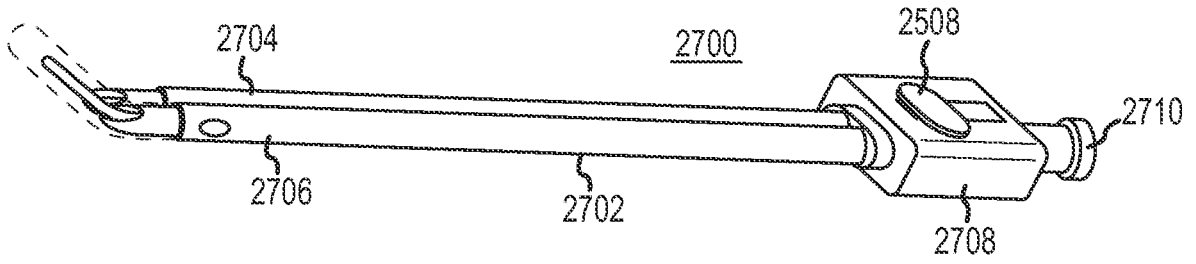

FIG. 27A

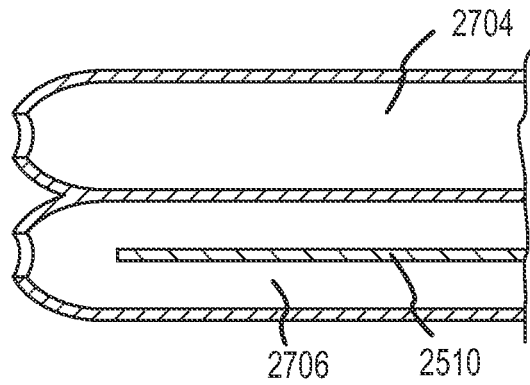

FIG. 27B

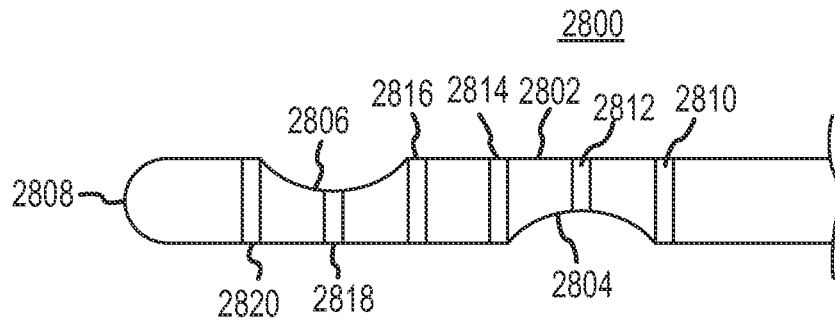

FIG. 28A

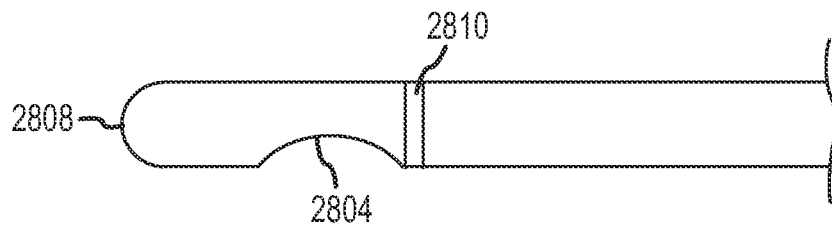

FIG. 28B

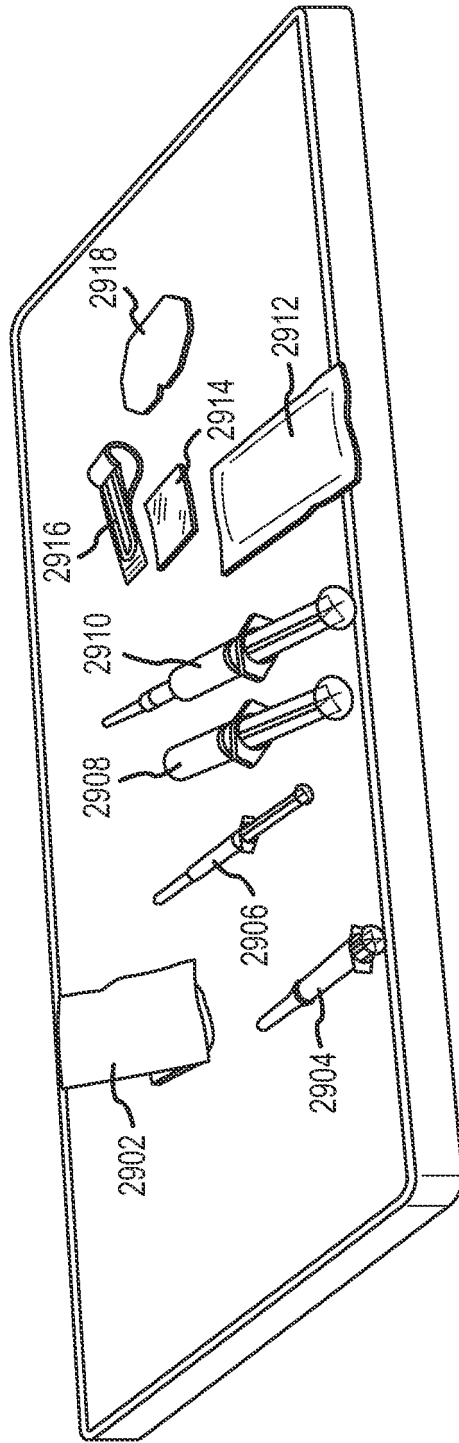

FIG. 29



FIG. 30

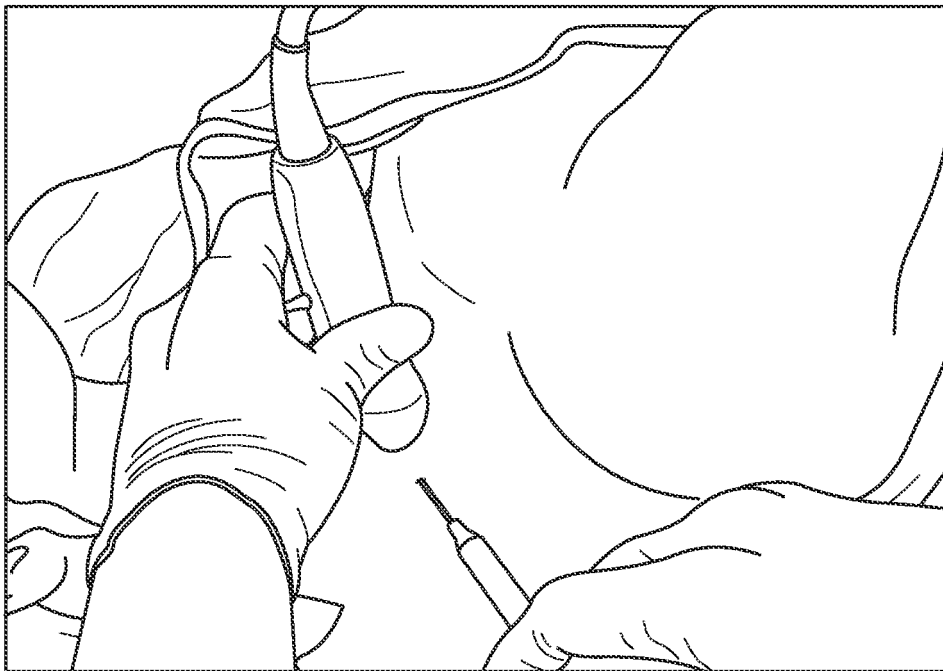

FIG. 31

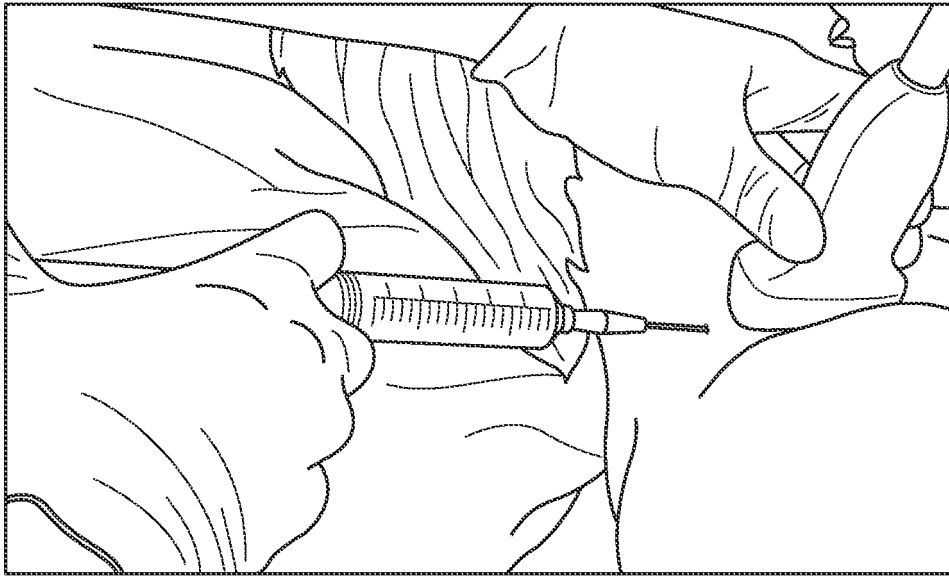

FIG. 32

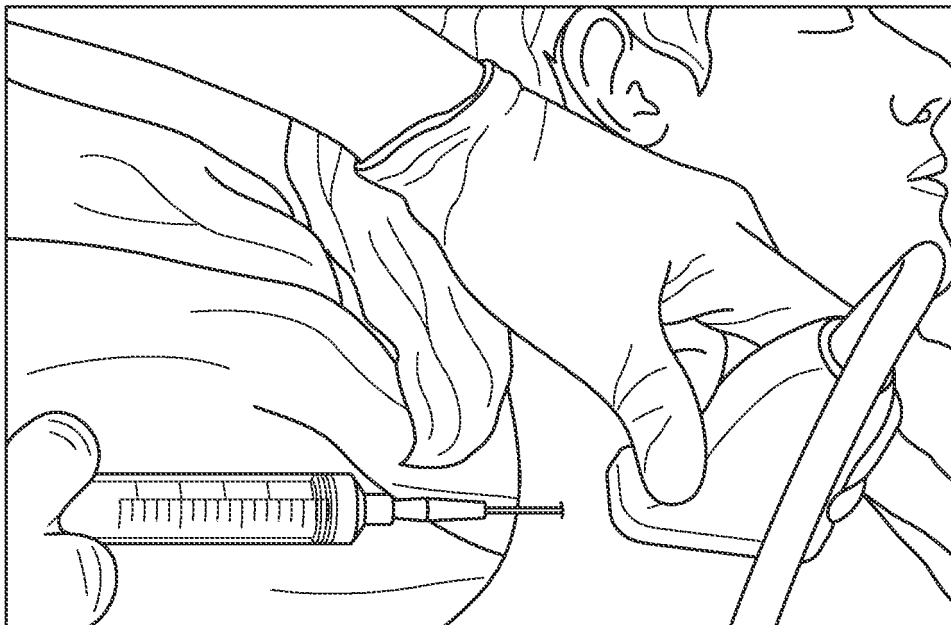

FIG. 33

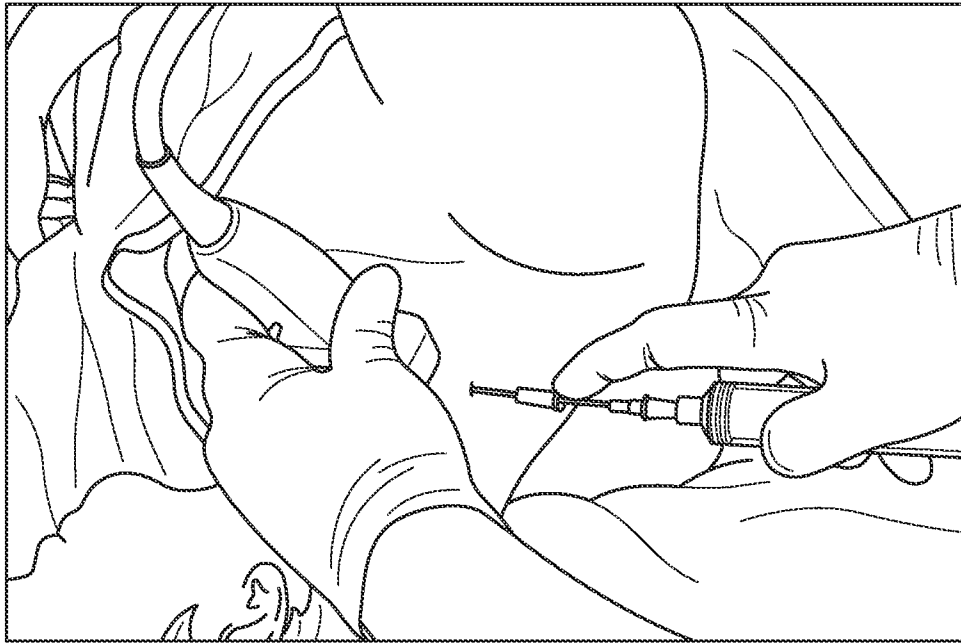

FIG. 34

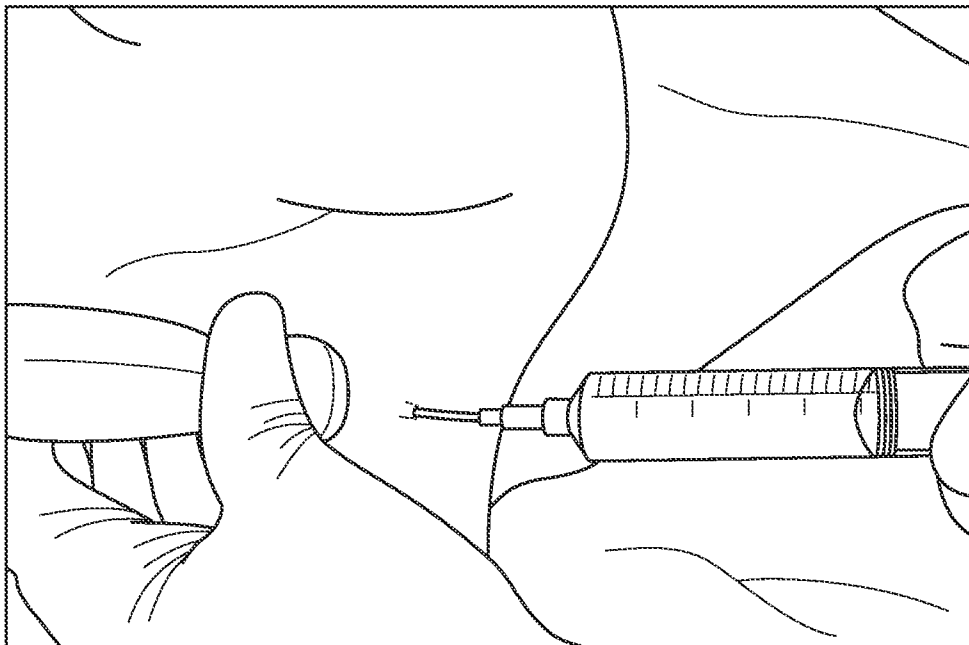

FIG. 35

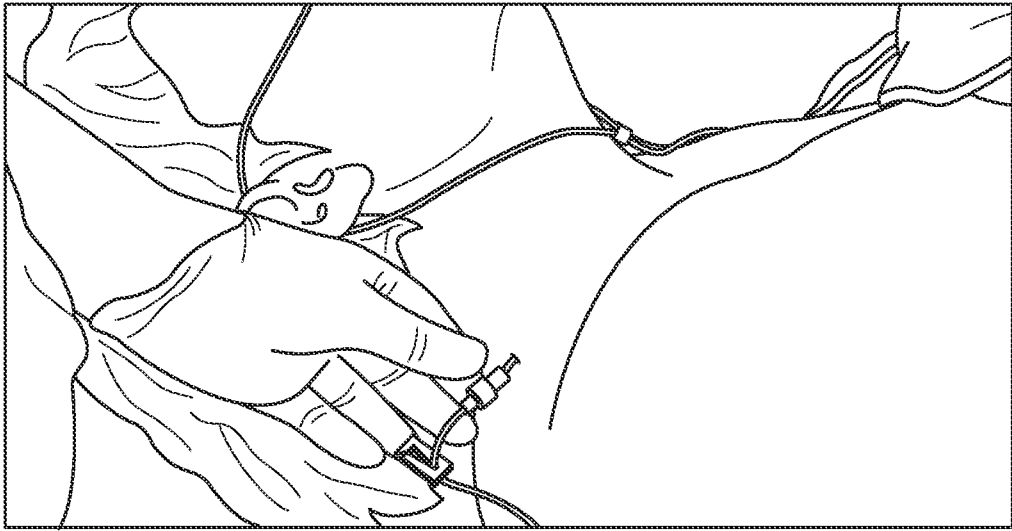

FIG. 36

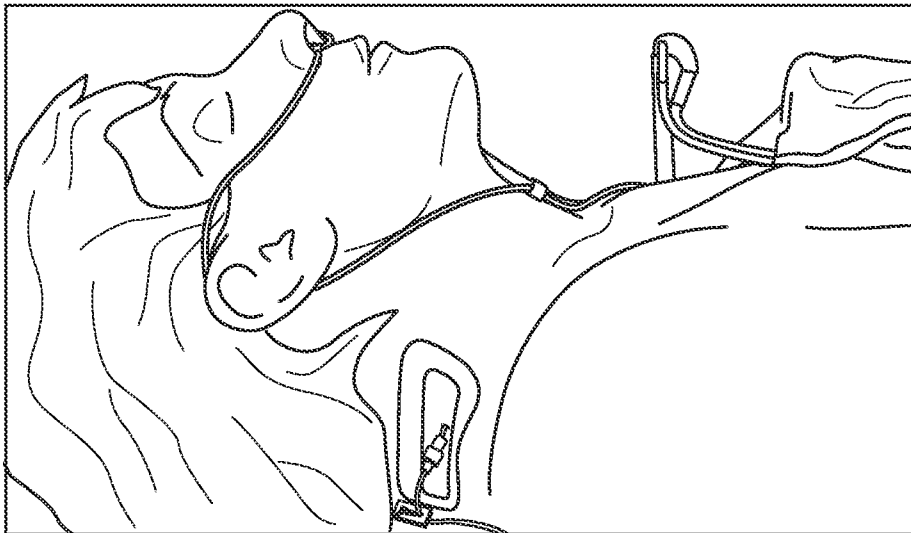

FIG. 37

REFERENCES CITED IN THE DESCRIPTION

This list of references cited by the applicant is for the reader's convenience only. It does not form part of the European patent document. Even though great care has been taken in compiling the references, errors or omissions cannot be excluded and the EPO disclaims all liability in this regard.

Patent documents cited in the description

- US 5976110 A [0004]
- US 6456874 B [0005]
- US 2010049171 A1 [0007]
- US 2005043709 A1 [0008]
- US 2005020965 A1 [0009]
- US 20110112511 A [0045]
- US 5284481 A [0052] [0056] [0057]
- US 7322961 B [0052] [0056] [0067]
- US 5352201 A [0052] [0056] [0087]
- US 5080652 A [0052] [0056] [0057] [0096]
- US 5105983 A [0057]
- US 7004923 B [0135]
- US 20120059308 A [0173]

专利名称(译)	连续麻醉神经传导装置，系统和方法		
公开(公告)号	EP2680920A4	公开(公告)日	2015-01-28
申请号	EP2012786621	申请日	2012-05-18
[标]申请(专利权)人(译)	SOLODEX		
申请(专利权)人(译)	SOLODEX LLC		
当前申请(专利权)人(译)	SOLODEX LLC		
[标]发明人	RAJENDRAN SUNDAR KOPACZ DAN JOEL		
发明人	RAJENDRAN, SUNDAR KOPACZ, DAN JOEL		
IPC分类号	A61N1/18 A61B8/08 A61B5/00 A61M5/142 A61M5/152 A61M25/01 A61M25/06 A61N1/05 A61N1/36		
CPC分类号	A61M5/142 A61M5/152 A61M25/0113 A61M25/0606 A61M25/0637 A61N1/0502 A61N1/0504 A61N1/36017 A61N1/36021 A61B5/0084 A61B8/481 A61M25/0108		
代理机构(译)	MOORE , BARRY		
优先权	61/487555 2011-05-18 US 61/532316 2011-09-08 US		
其他公开文献	EP2680920A2 EP2680920B1		
外部链接	Espacenet		

摘要(译)

本发明一般涉及一种连续麻醉神经传导装置及其方法，更具体地说，涉及一种用于连续流动或间歇推注麻醉剂以促进连续或延长的神经阻滞的方法和系统。在一个实施例中，该装置包括护套，该护套具有近端，远端和从近端延伸到远端的至少一个腔。护套还包括嵌入的导电元件，用于将电信号从护套的近端部分传递到护套的远端部分。套管布置在护套的至少一个内腔中并且具有从护套的远侧部分突出的远端。套管电耦合到嵌入式导电元件的至少一部分并且被配置为提供神经刺激。