

(19)



(11)

EP 2 162 076 B1

(12)

EUROPEAN PATENT SPECIFICATION

(45) Date of publication and mention of the grant of the patent:
08.03.2017 Bulletin 2017/10

(51) Int Cl.:
A61B 17/28 ^(2006.01) **A61B 5/00** ^(2006.01)
A61B 18/14 ^(2006.01)

(21) Application number: **08705996.0**

(86) International application number:
PCT/US2008/052460

(22) Date of filing: **30.01.2008**

(87) International publication number:
WO 2009/005850 (08.01.2009 Gazette 2009/02)

(54) **SYSTEM FOR MONITORING TISSUE DURING AN ELECTROSURGICAL PROCEDURE**

SYSTEM ZUR ÜBERWACHUNG VON GEWEBE WÄHREND EINES ELEKTROCHIRURGISCHEN EINGRIFFS

SYSTÈME PERMETTANT D'EXAMINER UN TISSU PENDANT UNE PROCÉDURE ÉLECTROCHIRURGICALE

(84) Designated Contracting States:
AT BE BG CH CY CZ DE DK EE ES FI FR GB GR HR HU IE IS IT LI LT LU LV MC MT NL NO PL PT RO SE SI SK TR

- **SYMS, Richard, R.a.**
London W13 9UZ (GB)
- **HANNA, George**
Fife DD6 8L2 (GB)

(30) Priority: **29.06.2007 US 937707 P**

(74) Representative: **Soames, Candida Jane et al**
Maschio & Soames IP Limited
30 Carlton Crescent
Southampton SO15 2EW (GB)

(43) Date of publication of application:
17.03.2010 Bulletin 2010/11

(73) Proprietor: **Covidien LP**
Mansfield, MA 02048 (US)

(56) References cited:
EP-A- 1 278 007 EP-A- 1 609 430
WO-A-01/01847 US-A1- 2004 015 163

(72) Inventors:
• **FLOUME, Timmy**
Harlesden NW104EX (GB)

EP 2 162 076 B1

Note: Within nine months of the publication of the mention of the grant of the European patent in the European Patent Bulletin, any person may give notice to the European Patent Office of opposition to that patent, in accordance with the Implementing Regulations. Notice of opposition shall not be deemed to have been filed until the opposition fee has been paid. (Art. 99(1) European Patent Convention).

Description**Technical Field**

5 [0001] The present invention relates to a system for monitoring macroscopic tissue modifications during an electro-surgical procedure, and more particularly to a system that quantifies the progress of tissue thermal damage and dehydration using optical monitoring.

Description of Related Art

10 [0002] Electrosurgical forceps use a combination of mechanical pressure and electrical energy to effect hemostasis, by heating tissue and blood vessels to coagulate, cauterize and/or seal tissue. By controlling the power, frequency and duration of the electrical energy delivered to the tissue, a surgeon can cauterise, coagulate, desiccate and/or slow bleeding. However, the delivered energy must be controlled in real-time as a function of the tissue state so that a reliable and reproducible surgical effect is generated.

15 [0003] To resolve the issues above and other issues relevant to coagulation and other tissue treatments, Valleylab Inc. (a division of Tyco Healthcare LP) has developed a technology called vessel or tissue sealing. Electrosurgical vessel sealing is fundamentally different from the process of coagulating vessels. For the purposes herein, "coagulation" is defined as a process of liquefying tissue wherein the tissue cells are ruptured and dried. Vessel sealing is defined as a process of liquefying collagen in tissue, so that it forms a fused mass with limited demarcation and capable of joining opposing tissue structures to seal a large vessel.

20 [0004] It is known in the art that the radio frequency (RF) energy delivery, the distance between jaw members in the sealing device and the pressure exerted by the jaw members must be controlled. In this way, the optimum tissue transformations leading to a seal can be generated, and hence a reproducible reliable seal can be achieved.

25 [0005] Two macroscopic effects that are induced in tissue during the RF tissue fusion process are thermal damage and dehydration. For the purposes herein, the term "thermal damage" is used to describe any bio-structural alteration of the tissue induced by heat. Thermal damage generally includes several biophysical modifications of the tissue that can ultimately lead to tissue death or denaturation - the loss of tridimensional protein structure.

30 [0006] The energy delivered to the tissue during an electrosurgical procedure and the consequent tissue transformations must be controlled and terminated so that a reliable seal is achieved. Historically, it was the responsibility of the surgeon to control and terminate the delivery of energy when the desired effect was produced. The experience of the surgeon was therefore of paramount importance. In the late 1980s, feedback controlled energy sources were introduced, in an effort to eliminate the need for empirical operation. For example, modifications to the tissue electrical impedance have been used as a feedback parameter in RF tissue fusion. Similarly, modifications to the optical properties of the tissue have been suggested to measure transformations induced by laser processing. Each of these methods has some drawbacks.

35 [0007] For example, impedance is often used to control the delivery of RF energy during tissue fusion, because it is relatively easy to measure and because dehydration is believed to reduce conductivity and, hence, increase impedance during the final stage of the fusion process. However, hydration does not completely correlate to impedance. As a result, impedance tends to be a less useful control parameter for the overall tissue sealing process.

40 [0008] Optical spectroscopy has the potential to provide more detailed information on the overall state of the tissue, since it allows information to be gathered on both the tissue structure and the tissue's biochemical makeup. In this case, there are much more significant metrological challenges, since the detectable signals are generally very weak. Further, algorithms are typically required to extract directly relevant information about the tissue-state from the raw optical signals.

45 [0009] Various prior art patents have proposed the use of optical measurements to control the delivery of energy during an electrosurgical procedure, e.g., US Patent Nos. 5,762,609; 5,769,791; 5,772,597; and 5,785,658 to Benaron. See also Applicant's own earlier disclosure in EP-A-1 609 430 and US-A- 2004/0015 163. These references disclose that signals can be measured either at or inside the surface of the tissue and that spectroscopy may be utilized in transmission or in reflection to monitor the signal. However, experiments show that the very large changes in scattering that occur in tissue can cause the signal detected by either method to be effectively extinguished during different stages of a thermal process, so that neither method on its own can provide continuous feedback. The systems proposed by Benaron also use raw optical parameters to control the electrosurgical generator, rather than extracted parameters such as thermal damage and tissue hydration.

SUMMARY OF THE INVENTION

55 [0010] The object of the present invention is to provide a more accurate system for optically monitoring and controlling the RF tissue fusion processes. The system disclosed herein is based on a system that combines transmission and

reflection spectroscopy to provide continuous data with an algorithm for accurate quantification of components such as water even in tissue with strongly varying scattering properties. The invention is defined in claim 1 below and the dependent claims are directed to optional features and preferred embodiments.

5 [0011] A system for monitoring tissue modifications during an electrosurgical procedure is disclosed. The system includes an electrical generator for generating RF energy and an electrosurgical apparatus including a pair of jaw members configured to grasp tissue therebetween, deliver RF energy to the tissue, and allow optical measurement of the tissue state by transmission and reflection spectroscopy.

10 [0012] The present disclosure relates to a system for monitoring and controlling tissue modification during an electrosurgical procedure and includes an electrosurgical apparatus that couples to an electrosurgical generator for generating electrical energy. The electrosurgical apparatus, e.g., a forceps, includes a pair of jaw members configured to grasp tissue therebetween and allow light transmission therethrough. The jaw members (or a portion thereof) may be transparent or translucent to accomplish this purpose. The system also includes an optical system having one or more optical sources which generate light (e.g., an optical transmission signal) of one or more wavelengths. At least a portion of the light is transmitted through tissue and at least a portion of the light is reflected from the tissue.

15 [0013] One or more optical detectors are included and are configured to analyze the portion of the light of being transmitted through tissue. The same or a different optical detector is configured to analyze the portion of the light being reflected from the tissue. A processor is operatively coupled to the optical system and to the electrosurgical generator and is configured to control the delivery of electrical energy from the electrosurgical generator to tissue based on information provided by the optical system by the detector(s).

20 [0014] In one embodiment, the optical system controls the electrosurgical generator in real time during the electrosurgical procedure. In another embodiment, the optical system detects thermal damage of tissue and/or hydration of tissue and cooperates with the electrosurgical generator via the processor to control the delivery of electrical energy to the tissue. The optical system may include a continuous wave device, a superluminescent light-emitting diode array and/or an incandescent lamp.

25 [0015] In still another embodiment, the optical system operatively connects to one or more optical fibres disposed through the electrosurgical apparatus. In yet another embodiment, the optical system includes one or more lenses for transmitting light therethrough. The optical system may also include a light delivery system and a light collection system, one or both of which being disposed fully or partially within the electrosurgical apparatus.

30 [0016] In embodiments, two different optical detectors may be utilized with the processor to analyze the signals - one to analyze transmitted signals and one to analyze reflected signals. For example, a Fabry-Perot interferometer or a dispersive spectrometer may be utilized as an optical detector.

35 [0017] The present disclosure enables a method for monitoring and controlling the delivery of electrosurgical energy to tissue during an electrosurgical procedure and includes the steps of: providing an electrosurgical apparatus including a pair of jaw members configured to grasp tissue therebetween and allow light transmission therethrough; generating electrical energy through tissue held between jaw members; generating light of one or more wavelengths at tissue; analyzing a spectral content of the light being transmitted through tissue and providing information relating thereto back to a processor; analyzing a spectral content of the light being reflected from the tissue and providing information relating thereto back to the processor; and controlling the delivery of electrical energy from the electrosurgical generator to tissue based information provided to the processor.

40 [0018] The present disclosure also enables a method for monitoring and/or controlling the delivery of electrosurgical energy to tissue during an electrosurgical procedure, the method includes the steps of: directing electrosurgical energy from an electrosurgical generator through tissue; directing an optical transmission signal of at least one wavelength into tissue; analyzing the strength of the optical transmission signal and determining if the optical transmission signal is below a predetermined detection limit; analyzing a spectral content of the optical transmission signal transmitted through tissue and providing information relating thereto back to a processor to control the delivery of electrosurgical energy to tissue based on the information provided to the processor until the strength of the optical transmission signal falls below the predetermined detection limit; and analyzing the spectral content of the optical transmission signal reflected from the tissue and providing information relating thereto back to the processor to control the delivery of electrosurgical energy to tissue based on the information provided to the processor.

50 [0019] In one embodiment, once the strength of the optical transmission signal rises above the predetermined detection limit, the processor resumes controlling the delivery of electrosurgical energy based on the optical transmission signal being transmitted through tissue until the electrosurgical procedure is completed.

BRIEF DESCRIPTION OF THE DRAWINGS

55 [0020] For a better understanding of the present invention, and to show more clearly how it may be carried into effect, reference will now be made to the accompanying drawings, in which:

Fig. 1 is a block diagram illustrating the components of a system for monitoring and controlling tissue during an electrosurgical procedure;

Fig. 2 is a perspective view of an endoscopic bipolar forceps shown in an open configuration;

Fig. 3 is an enlarged, front perspective view of the end effector assembly of Fig. 2;

Fig. 4A is a graph showing the measurement of attenuation taken at λ_1 and λ_2 when reflection spectroscopy is within the detection limit and transmission spectroscopy is outside the detection limit

Fig. 4B is graph showing the measurement of attenuation taken at λ_1 and λ_2 when transmission spectroscopy is within the detection limit and reflection spectroscopy is outside the detection limit;

Fig. 5 is a graph showing a theoretical representation of the product "d x DPF" with scattering loss "G" as obtained by a Monte Carlo Simulation;

Fig. 6A is a graph showing the transmitted light signal over time during a tissue fusion process; and

Fig. 6B is a graph showing the reflected light signal over time during a tissue fusion process.

DETAILED DESCRIPTION

[0021] The drawings will be better understood with reference to the following description. However, the disclosed embodiments are merely exemplary. The specific details disclosed should not be interpreted as limiting, but merely provide a basis for the claims and for teaching one skilled in the art to variously employ the invention.

[0022] Generally, the present invention provides a system for optical monitoring of tissue during a RF tissue procedure, by using continuous-wave transmission and reflection spectroscopy at different times to detect changes in scattering and in the absorption band associated with the vibration of water molecules near 1.45 μm wavelength. Processing of the transmission spectroscopy data allows the progress of both thermal damage and dehydration to be evaluated, thus providing a more accurate analysis of how the tissue is transformed during the fusion process. Such an analysis may allow improved understanding of the tissue modifications that lead to the high fusion quality. Processing of the reflection spectroscopy data allows control to be maintained, after it has been effectively extinguished due to increased scattering. The processed data obtained during the fusion process may be incorporated into a suitable feedback loop to control delivery of RF energy so that the optimum tissue transformations are obtained.

[0023] Fig. 1 shows the overall system 10, which includes an electrosurgical generator 101 operatively coupled to an electrosurgical instrument 200, represented here by a pair of jaws 102a, 102b. The electrosurgical instrument 200 is used to grasp a portion of tissue 103 and carry out an electrosurgical procedure thereon. The jaws 102a, 102b define openings 104a, 104b therein that are configured to allow the transmission of light therethrough, so that optical measurements may be performed on the grasped tissue 103 during the electrosurgical procedure.

[0024] The system 10 also includes an optical source 105 that is configured to generate broadband light and a beam delivery system 106, which in the embodiment shown includes of an optical fibre 106a and a collimating lens 107. A first portion of the light is transmitted through the tissue 103 via the openings 104a, 104b, where the light enters a first light collection system 108, which in the embodiment shown includes lens 108a and an optical fibre 109. A second portion of the light is reflected or back-scattered from the tissue 103, where it enters a second light collection system 110, which in the embodiment shown again consists of a lens 110a and an optical fibre 111. The fibres 109 and 111 are connected to an optical detection device 112, which is arranged to analyze separately the spectral content of the light transmitted and reflected from the tissue 103.

[0025] Other alternative optical arrangements are contemplated by the present disclosure that have the same or similar function. For example, the reflected or back-scattered light may be collected by the illumination lens 107 and illumination fibre 106 in a confocal arrangement, eliminating the need for the lens 110 and fibre 111. The reflected or back-scattered light may then be separated and passed to the detector 112 using a beam-splitting device. Such methods may be used without significant changes to the optical measurement scheme or to the subsequent data processing.

[0026] The system 10 also includes a processor 113 that is operatively coupled to the optical source 105 and the optical detection device 112 for transmitting instructions and data therebetween. The processor 113 is also coupled to the electrosurgical generator 101 and power output may be adjusted based on information derived from the data received from the optical detection device 112.

[0027] The electrosurgical generator 101 is operatively coupled to the electrosurgical apparatus for the purpose of performing an electrosurgical procedure such as sealing, cutting, coagulating, desiccating and fulgurating tissue using

RF energy. The electrosurgical apparatus can be any suitable type of electrosurgical apparatus, including but not limited to, apparatuses that can grasp tissue and/or perform any of the above mentioned procedures. One suitable type of apparatus may include bipolar forceps, for example as disclosed in U.S. Patent Application Publication No. 2007/0173814 A1. A brief discussion of bipolar forceps 200 is included herein to aid in understanding of the present disclosure.

5 **[0028]** Figs. 2 and 3 show one embodiment of a bipolar electrosurgical forceps 200 which includes a housing 201, a handle assembly 230, a rotating assembly 203, a trigger assembly 204 and a shaft 205. The shaft has a proximal end 206 that mechanically engages the rotating assembly 203, and a distal end 207 that engages an end effector assembly 208. Here, the term "proximal" refers to a component closest to the user, while the term "distal" refers to a component furthest from the user.

10 **[0029]** Forceps 200 also includes an electrosurgical cable 310 which connects the forceps 200 to a source of electrosurgical energy, e.g., a generator 101 (shown schematically). It is contemplated that generators such as those sold by Valleylab - a division of Tyco Healthcare LP, located in Boulder Colorado may be used as a source of electrosurgical energy, e.g., LigaSure™ Generator, FORCE EZ™ Electrosurgical Generator, FORCE FX™ Electrosurgical Generator, FORCE 1C™, FORCE 2™ Generator, SurgiStat™ II or other envisioned generators which may perform different or enhanced functions. One such system is described in commonly-owned U.S. Patent No. 6,033,399 entitled "ELECTRO-SURGICAL GENERATOR WITH ADAPTIVE POWER CONTROL". Other systems have been described in commonly-owned U.S. Patent No. 6,187,003 entitled "BIPOLAR ELECTROSURGICAL INSTRUMENT FOR SEALING VESSELS". As discussed in more detail below, generator 101 may include all components and parts as needed for system 10 to function and operate as intended.

20 **[0030]** Cable 310 may be internally divided into one or more cable leads (not shown) that are designed to transmit electrical potentials through their respective feed paths through the forceps 200 to the end effector assembly 208 such that upon activation of a switch 204 (See Fig. 2), energy is transmitted from the various cable leads to the respective feed paths and energy is transmitted through the tissue.

25 **[0031]** Handle assembly 230 includes a fixed handle 202 and a movable handle 215. Fixed handle 202 is integrally associated with housing 201 and handle 215 is movable relative to fixed handle 202. Rotating assembly 203 is operatively associated with the housing 201 and is rotatable approximately about a longitudinal axis "A-A" defined through the shaft 205.

30 **[0032]** As mentioned above, end effector assembly 208 is attached at the distal end 207 of shaft 205 and includes a pair of opposing jaw members 301 and 304. Movable handle 215 of handle assembly 230 is ultimately connected to a drive assembly (not shown) which, together, mechanically cooperate to impart movement of the jaw members 301 and 304 from an open position wherein the jaw members 301 and 304 are disposed in spaced relation relative to one another, to a clamping or closed position wherein the jaw members 301 and 304 cooperate to grasp tissue therebetween.

35 **[0033]** As shown in Fig. 3, an optical transmission port 305a for the delivery of light and an optical collection port 305b for reception of reflected light 305b are defined on the first jaw member 301. Various typed, sized and placed translucent elements may be used for this purpose and any number of ports 305a and 305b may be arranged along the jaw member 301 in a variety of different configurations depending upon a particular purpose or to achieve a particular result. In the particular arrangement shown in Fig. 3, the two ports 305a and 305b correspond to or can be synonymously associated with the single opening 104a in Fig. 1. In a similar manner, one or more collection ports (not shown) for the transmission or reception of light may be defined in the second jaw member 304 and, likewise, be correspondingly associated with single opening 104b in Fig. 1. Thus, the jaw members 301 and 304 of an electrosurgical forceps 200 may readily be adapted to provide suitably transparent light paths.

40 **[0034]** Returning to the overall system 10 in Fig. 1, the optical source 105 can be any suitable source that can produce or emit light in the wavelength range of about 1.2 μm to about 1.6 μm that straddles and includes the important water absorption band near 1.45 μm . Such sources may emit continuously over a broad spectral range. One example of a suitable compact, high-power continuous broadband source is a superluminescent diode array. However, other suitable forms of broadband source, such as incandescent lamps, may be utilized.

45 **[0035]** The continuous broadband source may also be replaced by a narrowband tuneable source, such as a tuneable laser. The use of such a source requires alteration to the detection scheme described below, but does not alter the essential nature of the measurement process and the data processing carried out thereafter.

50 **[0036]** Light from the optical source 105 can be delivered via an optical fibre 106a running through the shaft 205 to one or both jaw members 301 and 304 depending upon the particular configuration of the forceps 200. Suitable optical fibres include single- or multi-mode fibres, formed from glass or plastic. In one embodiment, the light path may be turned through approximately 90 degrees on exit from the fibre 106a and collimated by lens 107 to pass through the first translucent port 305a of the jaw member 301. Suitable components to achieve a change in direction of the optical path may include prisms, small mirrors and moulded plastic light pipes. Suitable elements to achieve collimation may include conventional lenses, ball lenses and graded index rod lenses. The lens 110a, fibre 111 and folded light path needed to collect reflected light from the second translucent port 305b may also be provided in the jaw member 301 in a similar way and using similar components. Alternatively, the translucent port 305b, lens 108a, fibre 109 and folded light path

needed to collect transmitted light may also be provided in the second jaw 304 in a similar way.

[0037] Light may be delivered to and collected from the end effector assembly 208 of the forceps 200 via three optical fibres 106a, 111 and 109 conveniently arranged as a single with electrical interconnects that carry power to the RF electrodes in the jaw members 310 and 304. At a suitable distance from the forceps 200, the individual optical fibres 106a, 111 and 109 may be separated and attached to optical fibre connectors (not shown) to allow removable or selectively detachable connection to the optical source 105 and optical detection system 112.

[0038] Additional fibres (not shown) carrying additional illumination light and collecting additional transmitted and/or reflected light and data from the tissue may also be provided. These additional fibres may be used for monitoring a variety of different tissue properties at different points along one or both jaw members 301 and 304, or, alternatively, may be configured for bidirectional monitoring of the tissue.

[0039] In the embodiment shown in Fig. 1, the optical detection device 112 includes two equivalent systems for separately analysing the spectral content of the transmitted and reflected light. The nature of the detection systems depends on the type of optical source utilized. For example, for a continuous broadband source such as a superluminescent diode array, scanning or staring filters such as Fabry-Perot interferometers or dispersive spectrometers are suitable. For a tuneable narrowband source, fixed detectors are suitable.

[0040] The processor 113 may be a microprocessor, laptop or personal computer connected to the light source 105, the detection system 112 and the electrosurgical generator 101 via suitable interface buses that allow transfer of command instructions and data. The processor may be configured to execute a control algorithm to start, control and stop delivery of electrical power to the electrosurgical device, e.g., forceps 200, during a RF tissue fusion operation, based on feedback parameters obtained by processing data acquired in real-time from the optical detection device 112.

[0041] The electrosurgical generator 101 may be a remotely controllable source of RF energy as used in electrosurgical procedures, for example as described in U.S. Patent Nos. 6,033,399 and 6,187,003. However, it will be apparent to those skilled in the art that other generators that perform similar or enhanced functions would also be suitable.

[0042] As previously described, the system 10 is configured to monitor the state of the tissue by evaluating the progress of both thermal damage and dehydration during an RF tissue fusion operation, by quantifying changes in optical scattering and water concentration. One contemplated control algorithm and associated mathematical equation is described below; however, a plurality of other algorithms, equations and derivations exist that achieve a similar objective, and therefore the embodiment presented should be considered illustrative rather than exclusive.

[0043] In operation, opposing jaw members 301 and 304 of the forceps 200 are used to grasp an area of tissue therebetween. Before RF energy is applied, transmission spectroscopy and/or reflection spectroscopy is performed to provide initial spectral analysis and information about the grasped tissue. The raw data obtained from this initial sampling may be used to derive an initial tissue scattering loss and tissue water concentration using a modified Beer-Lambert law model and derivations therefrom (see description below). Based on this data, an initial RF delivery strategy can be predicted, and this strategy may be extended and modified to the completion of the RF tissue fusion process based on subsequent similar measurements and processing.

[0044] The Beer-Lambert law is a mathematical relation that accounts for the concentration of absorbers in a non-scattering absorbing medium to be quantified. The intensity "I" of a light beam having an initial intensity "I₀" transmitted through a thickness "d" of such a medium is expressed by the equation:

$$(1) \quad I = I_0 e^{-u_a(\lambda) \cdot d}$$

[0045] Here " λ " is the wavelength and " $u_a(\lambda)$ " is the wavelength dependent absorption coefficient of the medium. For example, in tissue, the principal contributor to absorption near 1.45 μm wavelength is water. In this range the absorption coefficient is given by:

$$(2) \quad u_a(\lambda) = C_w \cdot \alpha_w(\lambda)$$

[0046] Here " C_w " is the concentration of water in the tissue and " $\alpha_w(\lambda)$ " is the specific absorption coefficient of water. For any suitable wavelength, the attenuation " $A(\lambda)$ " of the transmitted light can be defined as the logarithm of the ratio of the incident intensity to the transmitted intensity, given by:

$$(3) \quad A(\lambda) = -\log\left(\frac{I}{I_0}\right) = C_w \cdot \alpha_w(\lambda) \cdot d$$

[0047] Equation 3 in principle allows the concentration of water to be quantified from measurements of the transmission. However, when the medium is scattering - as is the case with tissue - Equation 3 may no longer be valid, because any estimate of the attenuation must take into account the modifications of path length as photons are scattered, and scattered light that is no longer detected. The attenuation may then be described using the modified Beer-Lambert law expressed as:

$$(4) \quad A(\lambda) = -\log\left(\frac{I_o}{I}\right) = C_w \cdot \alpha_w(\lambda) \cdot d \cdot DPF + G$$

[0048] Here the term "DPF" is the differential path factor, which accounts for the increase of the path length of the photons in a scattering medium, and the term "G" is the scattering loss and accounts for the loss of signal due to unabsorbed scattered light that is not detected. "G" is a strong function of the geometry of the optical system. Both the "DPF" and "G" are slowly varying functions of wavelength, but may be considered to be approximately constant over the small spectral range of interest here.

[0049] Figs. 4A and 4B show the effect of scattering on the attenuation spectrum of a medium near an absorption band. The spectrum of Fig. 4A corresponds to a medium with relatively high scattering. Here the attenuation is composed of a baseline due to scattering loss (e.g., the point labelled " λ_1 "), over which an absorption band is superimposed (e.g., the point labelled " λ_2 "). The spectrum of Fig. 4B corresponds to a medium with lower scattering. Here both the baseline and the height of the absorption band are reduced. The reduction in baseline follows from the reduction in scattering loss. The reduction in absorption follows from the shorter paths travelled by photons in the absorbing medium as the scattering is reduced.

[0050] Using similar data, attenuation measurements " $A(\lambda_1)$ " and " $A(\lambda_2)$ " can be obtained at wavelengths " λ_1 " and " λ_2 ". At " λ_1 ", far away from the absorption band, Equation 4 gives:

$$(5) \quad A(\lambda_1) \approx G$$

[0051] Hence, the value of G may be estimated from the measurement " $A(\lambda_1)$ ".

[0052] At " λ_2 ", at the peak of the absorption band, re-arrangement of equation 4 gives

$$(6) \quad C_w = \{A(\lambda_2) - G\} / \{ \alpha_w(\lambda_2) d \times DPF \}$$

[0053] Equation 6 allows the water concentration to be found from measurements " $A(\lambda_2)$ ", the calculated value of G, and the specific absorption coefficient of water " α_w " at the wavelength " λ_2 ", provided the product "d x DPF" is also known.

[0054] The value of the product "d x DPF" cannot be easily measured in a direct manner. However, it can be found by numerically modelling the propagation of light in a scattering slab and subsequent coupling the scattered light into a given optical system corresponding to the equipment used. Such a simulation may be carried out using either diffusion theory or a so-called "Monte Carlo simulation".

[0055] To a reasonable approximation, what is found is that the product "d x DPF" is mainly a function of "G", independent of any absorption in the slab. Fig. 5 shows the calculated variation of "d x DPF" as a function of "G" as it relates to an optical system. For low scattering (small "G"), the product "d x DPF" is approximately constant, suggesting that the "DPF" is also constant. For higher scattering (larger G), the product "d x DPF" rises rapidly which may be built into a simple functional model. For example, in the system disclosed herein, a reasonable approximation of the variation is given by the function:

$$(7) \quad d \times DPF \text{ (mm)} = 1 + (G/k)^n$$

[0056] Here k = 16 and n = 12.

[0057] Knowing "d x DPF", "G" and the measurement " $A(\lambda_2)$ ", the water concentration " C_w " may then be found using Equation 6. Repetitive measurement of spectral data, at at least the two wavelengths " λ_1 " and " λ_2 ", and repetitive use of Equations 5, 6 and 7 then allows both the scattering loss term "G" and the water concentration " C_w " to be found as

a function of time through a RF tissue fusion process.

[0058] An algorithm may then be constructed to control the RF power applied to the tissue by the electrosurgical generator 101 and the electrosurgical instrument, e.g., forceps 200, so that the concentration of water in tissue is reduced at a controlled rate to a controlled final level corresponding to a controlled final hydration state.

[0059] In practice, use of the algorithm may be complicated by the finite sensitivity of the measurement apparatus. For example, Fig. 6A shows a representative time variation of the transmitted signal, measured at the peak of the water absorption band, in one embodiment of a RF fusion experiment involving small bowel tissue. In the early time interval 601, the transmission is relatively high, and a usable signal is obtained. In this stage, the tissue is simply heated so that its temperature rises. However, in the time interval 602 the transmission signal falls rapidly as scattering increases due to thermal damage. In the time intervals 603a and 603b, the transmission signal is so low that it has fallen to or below the detection limit 605 of the combined optical system. In the final interval 604, when scattering typically falls due to the elimination of tissue water, the transmission rises again to a measurable level. The decrease in scattering with dehydration is explained by an increase in refractive index matching between scattering centre and ground substrate. The presence of a 'dead-band' or low detection state in which the transmitted signal is so low that the integrity of any information derived from the signal is questionable makes it difficult to formulate a reliable control algorithm for the electrosurgical generator during this time interval between 603a and 603b.

[0060] A solution as presented herein is provided by utilizing the availability of the corresponding reflected signal, shown in Fig. 6B. Here the reflected signal has a low initial value in the time initial interval 601, a sharply rising value in the time interval 602 as thermal damage begins, and reaches a maximum at the time 606, when the boiling point of the water in tissue is reached. The time 606 generally approximates the midpoint of the dead-band interval between 603a and 603b. At the end of this interval, the reflected signal starts to fall as the water in tissue is boiled off, usually falling to a lower value at the end of the final interval 604 (typically below a further detection limit 607).

[0061] The availability of one or other of the transmitted and reflected signals throughout the fusion process allows a reliable control algorithm to be constructed for the electrosurgical generator. Because the two signals contain information mainly about different aspects of the tissue-state, the algorithm used to control the electrosurgical generator may be configured to optimise these different aspects separately using the two signals.

[0062] Many different possible control algorithms may exist, and therefore the example described below is intended to be illustrative rather than exclusive. For example, at the start of a tissue fusion process, and after measuring initial optical data, it may be desirable to set the average power "P" delivered by the electrosurgical generator to a maximum value " P_0 ", so that the tissue is heated rapidly to the point where tissue transformations begin. The average power "P" may be held constant at " P_0 " throughout the time interval 601, until the transmission starts to fall. This point may be detected from the time variation of the transmitted signal.

[0063] During the time interval 602, when thermal damage is occurring, it may be desirable to reduce or control the average power "P" delivered by the electrosurgical generator so that the rate of change " dG/dt " of the extracted scattering loss parameter "G" is held at a constant value. This value may also be determined empirically. Because "G" is affected by thermal damage only, the rate of thermal damage may thereby be effectively controlled.

[0064] The algorithm used to extract the parameter "G" (See Equations 5 - 7) becomes unreliable when the transmitted signal reaches the detection limit 605. During the first part of the dead-band time interval 603a, before the point of maximum reflectance 606, the average power "P" delivered by the electrosurgical generator may therefore simply be held constant at " P_1 ", the power level reached at the end of the time interval 602. This strategy tends to eliminate the need to extract extraneous or potentially uncertain data from the transmitted signal.

[0065] Control is then switched and becomes a variable of the reflected signal, whose maximum 606 indicates that the boiling point of tissue water has been reached. At this point, the average power "P" delivered by the electrosurgical generator may be reduced to a lower value " P_2 ", to reduce damage caused by rapid evolution of steam within the tissue, and held constant at this level through the interval 603b.

[0066] The end of the interval 603b may be detected from a rise in the transmitted signal above the detection limit 605, and control may be passed back to data extracted from the transmitted signal. During the final interval 604, when tissue water is being driven off, it may be desirable to reduce or control the average power "P" delivered by the electrosurgical generator so that the rate of change " dC_w/dt " of the extracted water concentration " C_w " is held at a constant value. This value may also be determined empirically. The average power "P" may be switched off and the RF fusion process terminated at the end of the interval 604 when a given value " C_w " corresponding to a given hydration state has been reached.

[0067] In this manner, it will be apparent that control of the heating of the tissue is not only continuous, but adapted to ensure that rate of change of specific physical modifications in the tissue state may be optimised. It will also be apparent that the method of control is very flexible and may be developed further according to experience.

[0068] The present disclosure also enables a method for monitoring and controlling the delivery of electrosurgical energy to tissue during an electrosurgical procedure and includes the steps of: providing an electrosurgical apparatus, e.g., forceps 200, including a pair of jaw members 301 and 304 configured to grasp tissue therebetween and allow light

transmission therethrough; directing electrical energy from an electrosurgical generator 101 through tissue held between jaw members 301 and 304; generating light (e.g., an optical transmission signal) of one or more wavelengths at tissue; analyzing a spectral content of the light being transmitted through tissue and providing information relating thereto back to a processor 113; analyzing a spectral content of the light being reflected from the tissue and providing information relating thereto back to the processor 113; and controlling the delivery of electrical energy from the electrosurgical generator 101 to tissue based on information provided to the processor 113.

[0069] The present disclosure also enables a method for monitoring and/or controlling the delivery of electrosurgical energy to tissue during an electrosurgical procedure, the method includes the steps of: directing electrosurgical energy from an electrosurgical generator 101 through tissue; directing an optical transmission signal of at least one wavelength into tissue; analyzing the strength of the optical transmission signal and determining if the optical transmission signal is below a predetermined detection limit 605; analyzing a spectral content of the optical transmission signal transmitted through tissue and providing information relating thereto back to a processor 113 to control the delivery of electrosurgical energy to tissue based on the information provided to the processor 113 until the strength of the optical transmission signal falls below the predetermined detection limit 605; and analyzing the spectral content of the optical transmission signal reflected from the tissue and providing information relating thereto back to the processor 113 to control the delivery of electrosurgical energy to tissue based on the information provided to the processor 113.

[0070] In one embodiment, once the strength of the optical transmission signal rises above the predetermined detection limit 605, the processor 113 resumes controlling the delivery of electrosurgical energy based on the optical transmission signal being transmitted through tissue until the electrosurgical procedure is completed.

[0071] From the foregoing and with reference to the various figure drawings, those skilled in the art will appreciate that certain modifications can also be made to the present disclosure. For example, one or both jaw members 301 or 304 may be transparent or translucent depending upon a particular purpose.

[0072] In one embodiment, the optical system (and the various above-described optical components associated therewith) may be disposed across the two jaw members 301 and 304 with corresponding optical components in vertical or non-vertical registry depending upon a particular purpose.

[0073] Optical system 10 can also be configured to detect if tissue has been effectively cut after the tissue fusion process by utilizing one or more of the optical transmission elements and detectors as described above. That is, after an RF tissue fusion procedure has been performed, system 10 can be configured to scan the tissue or lack thereof after a cut has been performed to ensure a complete and accurate cut has been achieved. The contemplated configuration of at least four optical sources and detectors (or mirrors) may be configured to detect a portion of the light laterally (or transversally) across the tissue (e.g., across either side of a knife channel 360 as shown in Fig. 3) which can be employed to detect if the tissue has been effectively cut.

[0074] Several embodiments of the disclosure have been shown in the drawings. The above description should not be construed as limiting. Modifications are possible, within the scope of the claims appended hereto.

Claims

1. A system (10) for monitoring and/or controlling tissue modification during an electrosurgical procedure, the system comprising:

an electrosurgical apparatus (200) adapted to be connected to an electrosurgical generator (101), the electrosurgical apparatus including a pair of jaw members (301, 304) configured to grasp tissue (103) therebetween and allow light transmission therethrough;

an optical system including:

at least one optical source (105) configured to generate light at a first translucent port (305a) of a first one of the jaw members;

at least one optical detector (112) to collect light at a second translucent port (305b) in one of the jaw members of said pair, and configured to analyze a first portion of the light transmitted through the tissue and configured to analyze a second portion of the light reflected from the tissue; and

a processor (113) operatively coupled to the optical system and adapted to be connected to an electrosurgical generator, the processor configured to control the delivery of electrosurgical energy from an electrosurgical generator to tissue based on information provided by the optical system.

2. The system according to claim 1, wherein the optical system is configured to control the electrosurgical generator in real-time during the electrosurgical procedure.

3. The system according to claim 1, wherein the optical system detects at least one of thermal damage of tissue and hydration of tissue and is configured to cooperate with the electrosurgical generator via the processor to control the delivery of electrosurgical energy to the tissue.
- 5 4. The system according to claim 1, wherein the optical system includes a continuous wave device.
5. The system according to claim 1, wherein the optical system includes a superluminescent light-emitting diode array.
- 10 6. The system according to claim 1, wherein the optical system includes an incandescent lamp.
7. The system according to claim 1, wherein the optical system operatively couples to at least one optical fibre (106) disposed through the electrosurgical apparatus.
- 15 8. The system according to claim 1, wherein the optical system includes at least one lens (108) for transmitting light therethrough.
9. The system as claimed in any one of the preceding claims, wherein the electrosurgical apparatus is a bipolar forceps.
- 20 10. The system of any one of the preceding claims, wherein the second translucent port (305b) is in the first jaw member and collects reflected light.
11. The system according to claim 1, wherein the at least one optical detector is a Fabry-Perot interferometer.
- 25 12. The system according to claim 1, wherein the at least one optical detector is a dispersive spectrometer.
13. The system according to claim 1, wherein the optical system includes:
- a first optical detector configured to analyze the first portion of the light transmitted through tissue; and
a second optical detector configured to analyze the second portion of the light reflected from the tissue.
- 30 14. The system according to claim 1 wherein light is generated from the optical source in a wavelength range of about 1.2 μm to about 1.6 μm .
- 35 15. The system according to claim 1 wherein light is generated from the optical source in a wavelength range of 1.45 μm .

Patentansprüche

- 40 1. System (10) zur Überwachung und/oder Steuerung der Gewebemodifikation während eines elektrochirurgischen Verfahrens, wobei das System folgendes umfasst:
- eine elektrochirurgische Vorrichtung (200), die zur Verbindung mit einem elektrochirurgischen Generator (101) angepasst ist, wobei die elektrochirurgische Vorrichtung zwei Backenelemente (301, 304) beinhaltet, die zum Ergreifen von Gewebe (103) zwischen sich konfiguriert sind und eine Lichtübertragung dadurch ermöglichen;
- 45 ein optisches System, das Folgendes beinhaltet;
mindestens eine optische Quelle (105), die zur Erzeugung von Licht an einem ersten transluzenten Anschluss (305a) von mindestens einem der Backenelemente konfiguriert ist;
mindestens einen optischen Detektor (112) zum Sammeln von Licht an einem zweiten transluzenten Anschluss (305b) in einem der beiden Backenelemente, und Konfiguriert zur Analysierung eines ersten Teils des Lichts,
50 das durch das Gewebe übertragen wird, und Konfiguriert zur Analysierung eines zweiten Teils des Lichts, das vom Gewebe reflektiert wird; und
einen Prozessor (113), der operativ mit dem optischen System verbunden ist und angepasst ist, mit einem elektrochirurgischen Generator verbunden zu werden, wobei der Prozessor zur Steuerung der Abgabe von elektrochirurgischer Energie aus einem elektrochirurgischen Generator zum Gewebe basierend auf Informationen,
55 die vom optischen System bereitgestellt werden, konfiguriert ist.
2. System nach Anspruch 1, wobei das optische System zur Steuerung des elektrochirurgischen Generators in Echtzeit während des elektrochirurgischen Verfahrens konfiguriert ist.

EP 2 162 076 B1

3. System nach Anspruch 1, wobei das optische System mindestens eines aus dem Wärmeschaden des Gewebes und Hydratation von Gewebe erkennt und zur Kooperation mit dem elektrochirurgischen Generator über den Prozessor konfiguriert ist, um die Abgabe von elektrochirurgischer Energie an das Gewebe zu steuern.
- 5 4. System nach Anspruch 1, wobei das optische System eine Continuous-Wave-Vorrichtung beinhaltet.
5. System nach Anspruch 1, wobei das optische System eine superlumineszente lichtemittierende Diodenanordnung beinhaltet.
- 10 6. System nach Anspruch 1, wobei das optische System eine weißglühende Lampe beinhaltet.
7. System nach Anspruch 1, wobei das optische System operativ an mindestens einen Lichtwellenleiter (106) bindet, der durch die elektrochirurgische Vorrichtung angeordnet ist.
- 15 8. System nach Anspruch 1, wobei das optische System mindestens eine Linse (108) zur Übertragung von Licht dadurch beinhaltet.
9. System nach einem der vorstehenden Ansprüche, wobei die elektrochirurgische Anordnung eine bipolare Pinzette ist.
- 20 10. System nach einem der vorstehenden Ansprüche, wobei sich der zweite transluzente Anschluss (305b) im ersten Backenelement befindet und reflektiertes Licht einfängt.
11. System nach Anspruch 1, wobei der mindestens eine optische Detektor ein Fabry-Perot-Interferometer ist.
- 25 12. System nach Anspruch 1, wobei der mindestens eine optische Detektor ein dispersives Spektrometer ist.
13. System nach Anspruch 1, wobei das optische System Folgendes beinhaltet:
- 30 einen ersten optischen Detektor, der zur Analysierung des ersten Teils des Lichts, das durch Gewebe übertragen wird, konfiguriert ist; und
einen zweiten optischen Detektor, der zur Analysierung des zweiten Teils des Lichts, das vom Gewebe analysiert wird, konfiguriert ist.
- 35 14. System nach Anspruch 1, wobei Licht von der optischen Quelle in einem Wellenlängenbereich von etwa 1,2 μm bis etwa 1,6 μm erzeugt wird.
15. System nach Anspruch 1, wobei Licht von der optischen Quelle in einem Wellenlängenbereich von 1,45 μm erzeugt wird.
- 40

Revendications

- 45 1. Système (10) pour contrôler et/ou commander une modification tissulaire pendant une procédure électrochirurgicale, le système comprenant :
- un appareil électrochirurgical (200) conçu pour être relié à un générateur électrochirurgical (101), l'appareil électrochirurgical incluant un couple d'éléments formant mâchoires (301, 304) configurés pour saisir du tissu (103) entre ces derniers et permettre la transmission de lumière à travers ces derniers ;
- 50 un système optique incluant :
- au moins une source optique (105) configurée pour produire de la lumière au niveau d'un premier orifice translucide (305a) d'un premier des éléments formant mâchoires ;
- 55 au moins un détecteur optique (112) pour collecter la lumière au niveau d'un second orifice translucide (305b) dans un des éléments formant mâchoires dudit couple, et configuré pour analyser une première partie de la lumière transmise à travers le tissu et configuré pour analyser une seconde partie de la lumière réfléchie à partir du tissu ; et
- un processeur (113) couplé de façon opérationnelle au système optique et conçu pour être relié à un

EP 2 162 076 B1

générateur électrochirurgical, le processeur étant configuré pour commander la délivrance d'énergie électrochirurgicale à partir d'un générateur électrochirurgical à un tissu en se basant sur des informations fournies par le système optique.

- 5 **2.** Système selon la revendication 1, dans lequel le système optique est configuré pour commander le générateur électrochirurgical en temps réel pendant la procédure électrochirurgicale.
- 10 **3.** Système selon la revendication 1, dans lequel le système optique détecte au moins l'un de dégâts thermiques de tissu et d'hydratation de tissu et est configuré pour coopérer avec le générateur électrochirurgical via le processeur pour commander la délivrance d'énergie électrochirurgicale au tissu.
- 15 **4.** Système selon la revendication 1, dans lequel le système optique inclut un dispositif à onde continue.
- 5.** Système selon la revendication 1, dans lequel le système optique inclut un groupement de diodes superluminescentes émettant de la lumière.
- 6.** Système selon la revendication 1, dans lequel le système optique inclut une lampe incandescente.
- 20 **7.** Système selon la revendication 1, dans lequel le système optique est relié de manière opérationnelle à au moins une fibre optique (106) disposée à travers l'appareil électrochirurgical.
- 8.** Système selon la revendication 1, dans lequel le système optique inclut au moins une lentille (108) pour transmettre la lumière à travers cette dernière.
- 25 **9.** Système selon l'une quelconque des revendications précédentes, dans lequel l'appareil électrochirurgical est une pince bipolaire.
- 10.** Système selon l'une quelconque des revendications précédentes, dans lequel le second orifice translucide (305b) est dans le premier élément formant mâchoire et collecte la lumière réfléchie.
- 30 **11.** Système selon la revendication 1, dans lequel l'au moins un détecteur optique est un interféromètre de Fabry-Perot.
- 12.** Système selon la revendication 1, dans lequel l'au moins un détecteur optique est un spectromètre dispersif.
- 35 **13.** Système selon la revendication 1, dans lequel le système optique inclut :
- un premier détecteur optique configuré pour analyser la première partie de la lumière transmise à travers le tissu ; et
- un second détecteur optique configuré pour analyser la seconde partie de la lumière réfléchie à partir du tissu.
- 40 **14.** Système selon la revendication 1, dans lequel de la lumière est produite à partir de la source optique dans une plage de longueurs d'onde d'environ 1,2 μm à environ 1,6 μm .
- 45 **15.** Système selon la revendication 1, dans lequel de la lumière est produite à partir de la source optique dans une plage de longueurs d'onde de 1,45 μm .

50

55

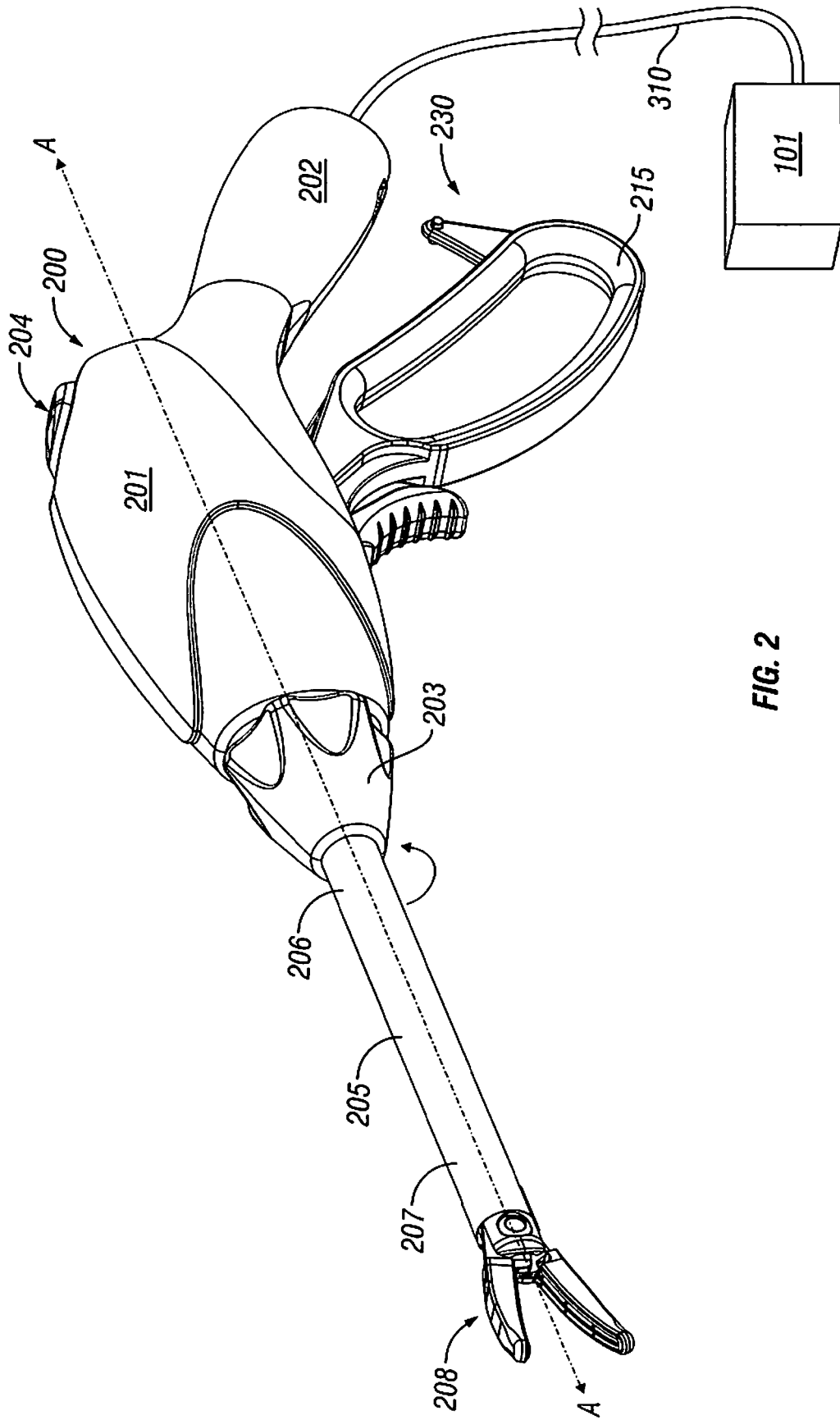

FIG. 2

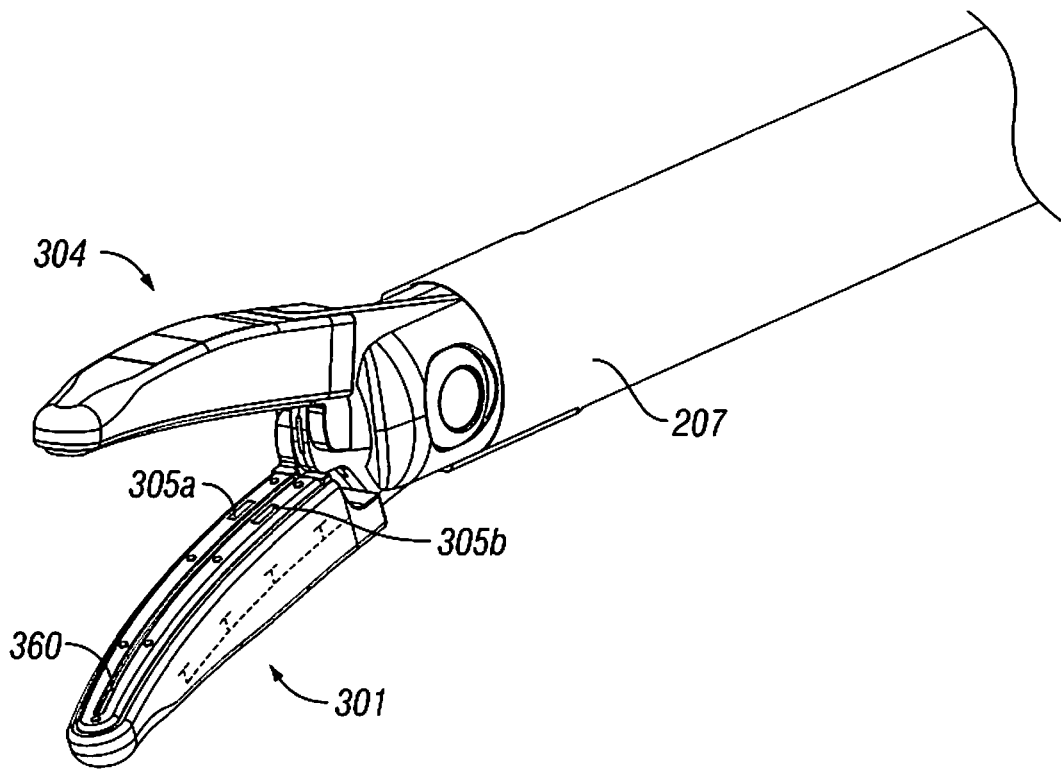

FIG. 3

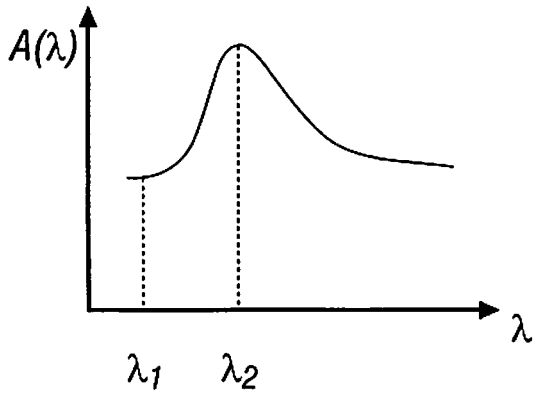

FIG. 4A

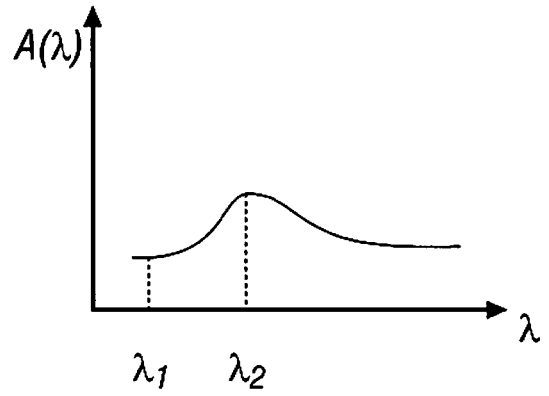

FIG. 4B

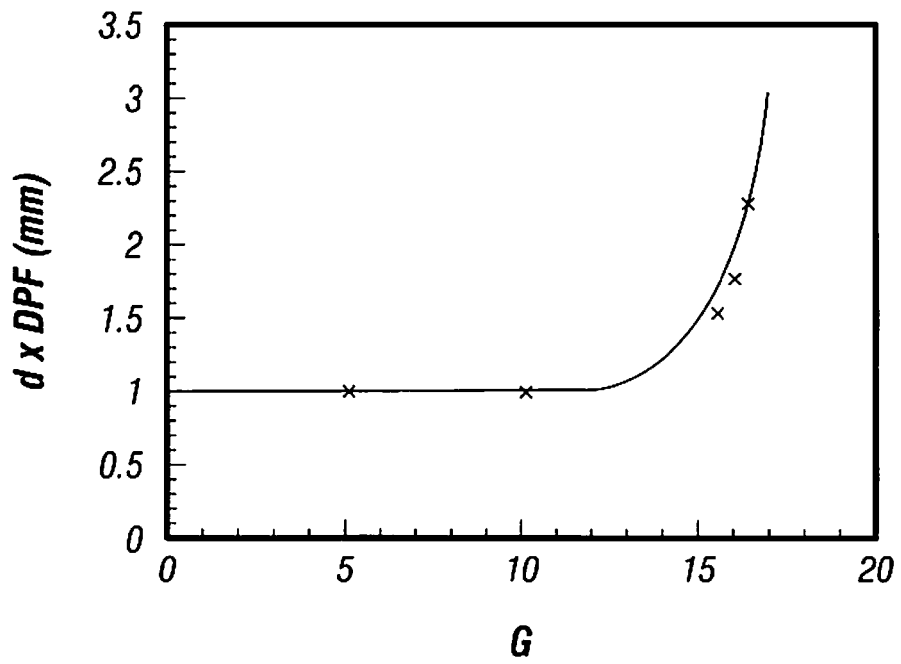

FIG. 5

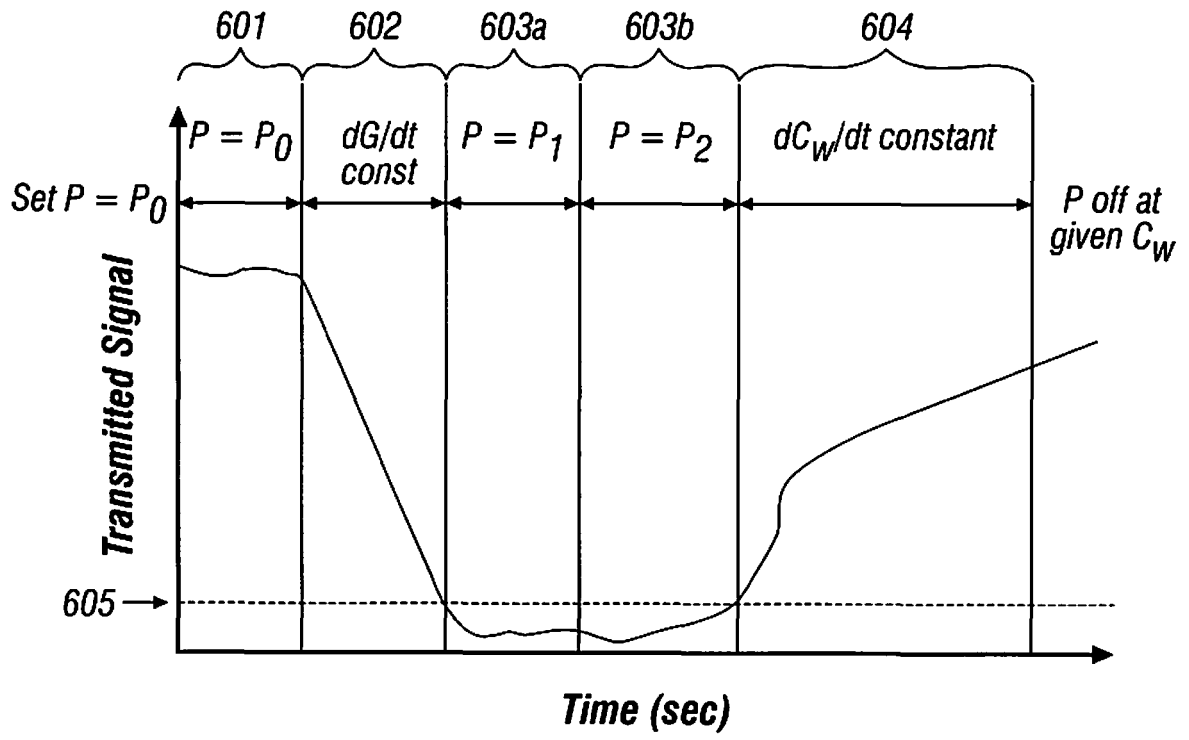

FIG. 6A

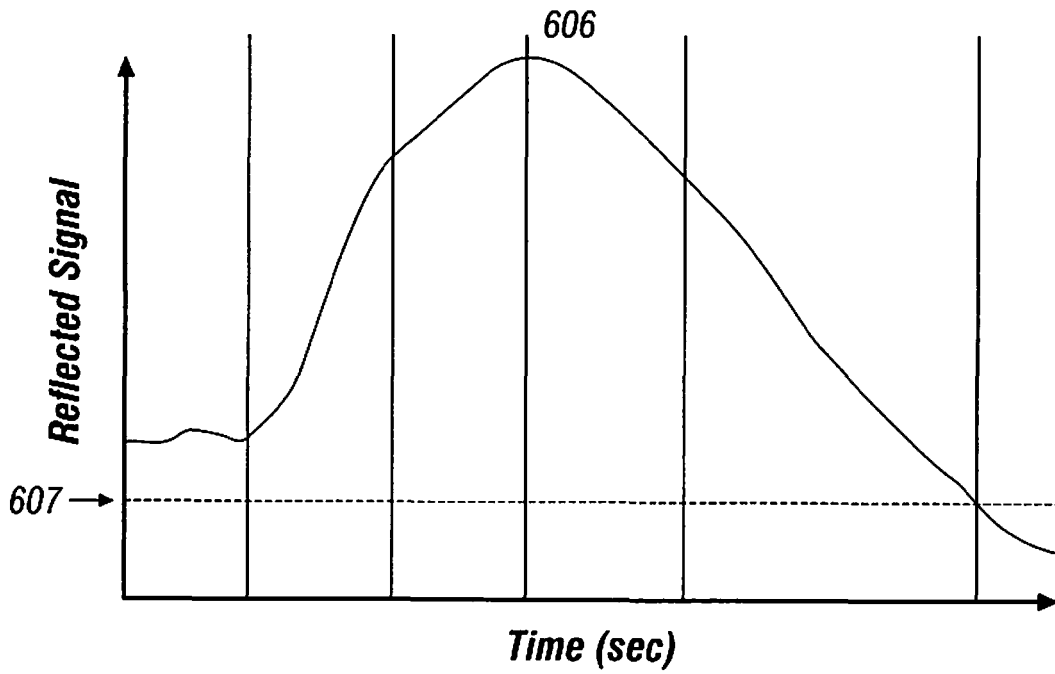

FIG. 6B

REFERENCES CITED IN THE DESCRIPTION

This list of references cited by the applicant is for the reader's convenience only. It does not form part of the European patent document. Even though great care has been taken in compiling the references, errors or omissions cannot be excluded and the EPO disclaims all liability in this regard.

Patent documents cited in the description

- US 5762609 A [0009]
- US 5769791 A [0009]
- US 5772597 A [0009]
- US 5785658 A, Benaron [0009]
- EP 1609430 A [0009]
- US 20040015163 A [0009]
- US 20070173814 A1 [0027]
- US 6033399 A [0029] [0041]
- US 6187003 B [0029] [0041]

专利名称(译)	用于在电外科手术期间监测组织的系统		
公开(公告)号	EP2162076B1	公开(公告)日	2017-03-08
申请号	EP2008705996	申请日	2008-01-30
[标]申请(专利权)人(译)	柯惠有限合伙公司		
申请(专利权)人(译)	泰科医疗集团LP		
当前申请(专利权)人(译)	COVIDIEN LP		
[标]发明人	FLOUME TIMMY SYMS RICHARD R A HANNA GEORGE		
发明人	FLOUME, TIMMY SYMS, RICHARD, R.A. HANNA, GEORGE		
IPC分类号	A61B17/28 A61B5/00 A61B18/14		
CPC分类号	A61B17/2812 A61B5/0059 A61B18/1445 A61B2017/00061 A61B2018/00702 A61B2018/00875		
优先权	60/937707 2007-06-29 US		
其他公开文献	EP2162076A1		
外部链接	Espacenet		

摘要(译)

用于在电外科手术期间监视和/或控制组织改变的系統包括电外科设备，该电外科设备连接到电外科发生器并且被配置为通过一对钳夹构件抓住其间的组织。该系统还包括具有光源的光学系统，该光源将光引导通过组织。一个或多个光学检测器分析透过组织并从组织反射回来的光，并且处理器利用该信息来控制从电外科发生器到组织的电外科能量的传递。



(15) **EUROPEAN PATENT SPECIFICATION**

(40) Date of publication and number of the grant of the patent: 08.03.2017, Bulletin 2017/110

(21) Application number: 08705996.0

(22) Date of filing: 30.01.2008

(84) Designated Contracting States: AT BE BG CY CZ DE DK EE ES FI FR GB GR HU IE IL IT LI LU LV MC MT NL NO PL PT RO SE SI SK TR

(30) Priority: 29.06.2007 US 937707 P

(43) Date of publication of application: 17.03.2010, Bulletin 2010/11

(72) Inventor: FLOUME, Timmy, Harlesden NW10AEK (GB)

(11) **EP 2 162 076 B1**

(51) Int. Cl. A61B 17/28 (2006.01) A61B 5/00 (2006.01) A61B 18/14 (2006.01)

(86) International application number: PCT/US2008/002460

(87) International publication number: WO 2009/005550 (08.01.2009 Gazette 2009/02)

(54) **SYSTEM FOR MONITORING TISSUE DURING AN ELECTROSURGICAL PROCEDURE**
 SYSTEME ZUM ÜBERWACHUNG VON GEBEWBE WÄHREND EINES ELEKTROCHIRURGISCHEN EINGRIFFS
 SYSTÈME PERMETTANT D'EXAMINER UN TISSU PENDANT UNE PROCÉDURE ÉLECTROCHIRURGICALE

(74) Representative: Soames, Candota Jane et al, Manchio & Soames IP Limited, 30 Carlton Crescent, Southampton SO15 2EW (GB)

(56) References cited: EP A 1 278 007 EP A 1 609 230 WO A 0101647 US A 7,2004,915,163

Note: Within nine months of the publication of the invention of the grant of the European patent in the European Patent Bulletin, any person may give notice to the European Patent Office of opposition to that patent, in accordance with the Implementing Regulations. Notice of opposition shall not be deemed to have been filed until the opposition fee has been paid. (Art. 99(1) European Patent Convention)

FORM PA 0001 (01/07) PATO (01/07)

EP 2 162 076 B1