



(11) **EP 1 845 872 B1**

(12) **EUROPEAN PATENT SPECIFICATION**

(45) Date of publication and mention of the grant of the patent:
27.10.2010 Bulletin 2010/43

(21) Application number: **06748180.4**

(22) Date of filing: **01.02.2006**

(51) Int Cl.:
A61B 5/00 ^(2006.01) **A61M 25/00** ^(2006.01)
A61M 1/06 ^(2006.01) **A61M 31/00** ^(2006.01)
A61M 37/00 ^(2006.01) **A61M 5/178** ^(2006.01)
A61M 5/315 ^(2006.01) **A61F 11/00** ^(2006.01)

(86) International application number:
PCT/US2006/003522

(87) International publication number:
WO 2006/096262 (14.09.2006 Gazette 2006/37)

(54) **GUIDE WIRE ADVANCER ASSEMBLY**

FÜHRUNGSDRAHT-ERWEITERUNGSANORDNUNG

ENSEMBLE DESTINE A FAIRE AVANCER UN FIL DE GUIDAGE

(84) Designated Contracting States:
AT BE BG CH CY CZ DE DK EE ES FI FR GB GR HU IE IS IT LI LT LU LV MC NL PL PT RO SE SI SK TR

(30) Priority: **02.02.2005 US 649310 P**

(43) Date of publication of application:
24.10.2007 Bulletin 2007/43

(73) Proprietors:
• **Medical Components, Inc.**
Harleysville, PA 19438 (US)
• **Raulerson, J. Daniel**
Brewton, AL 36426 (US)
• **Schweikert, Timothy M.**
Levittown, PA 19054 (US)

(72) Inventors:
• **RAULERSON, J. Daniel**
Brewton, AL 36426 (US)
• **SCHWEIKERT, Timothy M.**
Levittown, PA 19054 (US)

(74) Representative: **Forsthuber, Martin**
Patentanwaltskanzlei Matschnig & Forsthuber
OG
Siebensterngasse 54
1071 Wien (AT)

(56) References cited:
EP-A- 0 554 754 US-A- 5 282 479
US-A- 5 810 012 US-A1- 2003 036 712
US-B1- 6 551 281

EP 1 845 872 B1

Note: Within nine months of the publication of the mention of the grant of the European patent in the European Patent Bulletin, any person may give notice to the European Patent Office of opposition to that patent, in accordance with the Implementing Regulations. Notice of opposition shall not be deemed to have been filed until the opposition fee has been paid. (Art. 99(1) European Patent Convention).

Description

[0001] This application claims priority from United States Provisional Patent Application Serial No. 60/649,310 filed February 2, 2005.

[0002] The invention relates to medical devices and more particularly to guide wire advancers.

[0003] Catheters may be used for introducing and removing fluids in and from various vessels and cavities throughout the body. Central venous catheters, for example, are generally placed in four common locations within the chest and/or in the femoral vessels. They may be placed, for example, in either the right or left subclavian vein or in the right or left internal jugular vein. Such catheters use a guide wire to properly place the catheter in the catheterized area.

[0004] Using landmarks, vessels are identified and may be cannulated by first aspirating the vessel with a long hollow needle, which may be attached to a syringe or other aspirating device to ensure that the vessel has been properly located. When the vessel has been properly located and aspirated, if a syringe is used, the syringe is disconnected and a thin guide wire is passed through the needle into the hollow passage, or lumen, of the vessel. Other introducers allow the guide wire to pass through the syringe or device without removing the device from the needle. The needle or other introducer device is then removed, leaving one end of the guide wire within the vessel. The other end of the guide wire projects beyond the surface of the skin.

[0005] At this point, the simplest method of catheter placement is to pass a catheter into the vessel directly over the guide wire. The guide wire is then removed, leaving the catheter in position within the vessel. The catheter as placed can then function in various applications such as infusion, perfusion, hemodialysis and the like.

[0006] The guide wires used for such procedures are generally spring wires, which typically have a curved J-shaped tip. The nature of the spring wire, which is typically constructed from a memory alloy, causes the tip to return to the J-shape after applied stress is removed. Therefore, in order to slide the tip through the device and to keep the wire from bending back on itself while entering the patient, such wires are typically introduced through a straightening device. The guide wire has a relatively long length. For convenience, the wire is typically packaged and used as a coil. The coils generally have plastic clips which help to hold the coil together for handling. In addition, the coils can be packaged in protective storage tubes which also may use clips to hold the tubes in a coiled configuration.

[0007] The mechanical difficulties encountered by a physician or other medical personnel using such guide wires typically are the result of the need to use two hands to handle the guide wire and to operate an advancing apparatus while inserting the guide wire through the needle into the patient. Various prior art devices are directed

to simplifying the advancing and insertion procedure, including a plastic cone having a hole at the tip of the cone for passing the guide wire through the hole into the introducer hub, and a shuttling device as described in U.S. Pat. No. 4,713,059. These devices, while assisting in advancing the wire through the introducer and guiding the wire into the needle, require two hands to operate.

[0008] Syringes have been adapted which advance and straighten the wire and pass the wire through the syringe directly into the needle without detaching the syringe. While such devices minimize bleeding, they are highly specialized and complex with respect to the central passages and valves within the syringe, and occasionally, difficulty is still encountered in feeding the guide wire into the end of the syringe, requiring a peripheral straightening device. Due to the more complex nature of such syringes, while they may improve effectiveness in handling the guide wire, they are relatively expensive to manufacture. Examples of guide wire introducing syringes may be found in U.S. Pat. Nos. 4,274,408, 4,417,886, 4,813,938, and 5,045,065.

[0009] Other solutions to the problem of two-handed guide wire advancing and straightening include a device as described in U.S. Pat. No. 5,125,906, which teaches a trigger-like handle with a clip which can be attached to a guide wire feeding tube or coil. The device has a frustoconical, tapered, distal end portion. The device is held with the fingers coiled around the trigger handle and the guide wire is fed into the device through a proximal opening, slid across a flat surface by the thumb and through the distal end portion into a syringe or needle introducer. A modified version of the device is disclosed in U.S. Pat. No. 5,484,419, which includes an additional, separate conical end fitting which can be placed over the end portion to help feed the guide wire into the needle and which has an arched underneath surface for facilitating handling of the device to enhance sliding of the guide wire over a flat top surface of the device. One problem with these guide wire advancers is the inability of the physician to accurately determine whether and how far the guide wire is advancing into the vessel using the thumb alone.

[0010] A virtually identical device is described in U.S. Pat. No. 5,507,300, which provides a rubber band along the wire guide to allow the physician to stop the insertion of the guide wire without letting the guide wire slip along the guide.

[0011] U.S. Pat. No. 5,366,444 discloses a guide wire advancer which provides a head with a guide opening, a discharge opening, and an open platform therebetween. A guide wire is advanced over the platform with a thumb, with a forefinger engaging a depression on an underside of the platform.

[0012] Other devices disclosed by U.S. Pat. Nos. 4,860,757, 4,917,094, 5,273,042, 5,438,993, and 5,448,993 describe a guide wire housed in a tube with apertures or a conical straightener as described above with a thumb opening cut into the conical portion. A physician's thumb fits into the aperture to engage the guide

wire to advance or retract the guide wire through the tube.

[0013] A device disclosed by U.S. Patent No. 6,551,281, invented by the present inventor, describes a guide wire advancer with an open central portion that flexibly connects a proximal portion and a distal portion through which a guide wire is contained. A physician grasps the guide wire between thumb and forefinger at the central portion and feeds the guide wire through the distal portion. Alternatively, while grasping the guide wire between the thumb and forefinger as described above, the physician advances the guide wire distally, compressing the open central portion by disposing the proximal portion toward the distal portion. Upon release of the guide wire and the advancer, the open central portion reverts to its original shape. Friction between the guide wire and the blood vessel into which the guide wire has been inserted keeps the guide wire from being pulled out of the vessel.

[0014] The above-described guide wire straighteners allow guide wires to be inserted in limited ways. However, different physicians have different preferences on techniques to be employed to advance a guide wire. Each of the guide wire advancers described above may require a physician to insert a guide wire using a technique or method with which he or she is uncomfortable or unfamiliar, risking potential injury to the patient during insertion.

[0015] Therefore, there is a need in the art for a guide wire advancer and/or straightening device which is alternatively operable through at least one of several alternate methods so that the physician inserting the guide wire has the option of using the method with which he or she is most comfortable using.

[0016] The present invention is a guide wire advancer as further disclosed in claim 1 including a body having a longitudinal axis and having a first advancer portion adapted to enable a first advancing technique, and at least a second advancer portion adapted to enable at least a second advancing technique. The first portion is adapted to allow a user to advance a guide wire along the longitudinal axis using a finger and a thumb to directly frictionally engage the wire, by providing a large opening exposing the guide wire as it extends across the large opening. The second portion is adapted to allow a user to advance a guide wire along the longitudinal axis using only one finger or the thumb to bias the guide wire against a platform of the second portion when advancing the guide wire. The more distal of the first and second portions includes a distal tip portion that is preferably frustoconical. Optionally, the first and second portions may be independently rotatable about the longitudinal axis.

[0017] Preferably, the first portion comprises distal and proximal portions that define aligned first and second passageways therethrough through which the guide wire extends and is advanced. Also, preferably, the first portion comprises a central portion having first and second members extending between the distal and proximal portions, with the first and second members diverging and

then converging, thus defining the large opening therebetween. The first and second members may be flexible and may be manually deformed to urge the proximal portion toward the distal portion to advance the guide wire, with the practitioner holding the proximal and distal portions, and providing a third optional advancing technique.

[0018] The guide wire advancer thus provides three optional advancing techniques by the practitioner. The practitioner also may use more than one of the techniques sequentially at his or her discretion. The method of the present invention includes providing a guide wire advancer having the first and second portions set forth hereinabove, and selecting one or more of the plurality of optional techniques to advance the guide wire.

[0019] The accompanying drawings, which are incorporated herein and constitute part of this specification, illustrate the presently preferred embodiments of the invention, and, together with the general description given above and the detailed description given below, serve to explain the features of the invention. In the drawings:

[0020] Fig. 1 is a perspective view of a guide wire advancer assembly in accordance with the present invention;

[0021] Fig. 2 is a top plan view of the guide wire advancer assembly of Fig. 1;

[0022] Fig. 3 is a cross-sectional view of the guide wire advancer assembly taken along line 3--3 of Fig. 2;

[0023] Fig. 3A is a perspective view of a proximal portion of the advancer of Fig. 1;

[0024] Fig. 4 is a cross-sectional view of the advancer taken along line 4--4 of Fig. 2;

[0025] Fig. 4a is a cross-sectional view of the advancer taken along line 4a--4a of Fig. 2;

[0026] Fig. 5 is a cross-sectional view of a portion of the advancer assembly of Fig. 1 inserted into an introducer needle which has been inserted into a patient;

[0027] Fig. 6 is a side elevational view showing a user manipulating a guide wire using the guide wire advancer assembly according to a first method of using the present invention;

[0028] Fig. 7 is a side elevational view showing a user manipulating a guide wire using the guide wire advancer assembly according to a second method of using the present invention; and

[0029] Fig. 8 is a side elevational view showing a user manipulating a guide wire using the guide wire advancer assembly according to a third method of using the present invention.

[0030] Certain terminology is used in the following description for convenience only and is not limiting. The words "distal" and "proximal" respectively designate directions in the drawings toward and away from the insertion end of the device. The terminology includes the words above specifically mentioned, derivatives thereof and words of similar import.

[0031] Referring to the drawings in detail, there is shown in Figs. 1 and 2 a guide wire advancer assembly, generally designated as 100, and a guide wire advancer,

generally designated as 102, according to one preferred embodiment of the present invention. The assembly 100 includes the advancer 102 and a guide wire storage tube 104, which is connected to a proximal end 106 of the advancer 102. A guide wire 107 is stored in the tube 104 and extends through the advancer 102 for insertion into a blood vessel.

[0032] The advancer 102 is comprised of a body having a proximal portion 108 and a distal portion 110. A longitudinal axis 112 extends through the advancer 102, co-linear with the portion of the guide wire 107 that extends through the advancer 102.

[0033] Referring now to Fig. 3, the distal portion 110 includes a passageway 114 which extends longitudinally therethrough, preferably along the longitudinal axis 112. The diameter of the passageway 114 is preferably sized to receive the guide wire 107 therein. Preferably, for different gauge guide wires, the diameter of the passageway 114 and the associated advancer 102 can be larger or smaller with respect to the size of the guide wire 107 to be used. The diameter of the passageway 114 should be sized such that the guide wire 107 fits through snugly, with minimal clearance between the outer diameter of the guide wire 107 and the diameter of the passageway 114 of the distal portion 110, but not so tightly as to inhibit advancement of the guide wire 107 through the passageway 114. Preferably, the guide wire 107 should substantially fill a lumen to minimize blood loss through a separate introducer such as an introducer device (not part of the present invention) but should still be able to be advanced smoothly through the lumen in the introducer device and into a patient without too much effort on the part of the physician or other medical personnel using the advancer assembly 100.

[0034] The introducer device used can vary and many are known in the art. The introducer device may be a conventional introducer or the advancer may be used to feed directly into a catheter and/or catheter fitting which can itself serve as an introducer. As such, "introducer device" as used herein includes any intervening device between the advancer 102 and the patient's vessel or cavity for receiving the guide wire 107. For example, the introducer device may be a needle having a proximal coupling or other fitting which remains distally inserted in a patient after disconnect of an aspirating syringe, or an apparatus such as a catheter introducer syringe which has a needle end inserted in the patient and a syringe body or other proximal attachment connected to the needle. Alternatively, the introducer device may be a one-step introducer bulb (not shown), as disclosed in U.S. Patent No. 6,277,100. When such syringes, or similar devices, are used as the introducer device, the proximal opening for inserting the advancer 102 would generally be located on the proximal end of the syringe body or other proximal needle attachment. If the introducer device is a needle, the opening for inserting the tip 120 of the advancer 102 would be the coupling or other proximal end fitting on the needle after the aspirating syringe has

been removed.

[0035] Referring still to Fig. 3, the distal portion 110 of the advancer 102 includes a proximal end 116, a distal end 118, and a central portion 119 that extends between the proximal end 116 and the distal end 118. The distal end 118 includes a tip 120 which may have any suitable shape. Preferably, the tip 120 is configured to fit within a fitting on the proximal end of an introducer such as the introducer device described above. The tip 120 is preferably conical, but may be also be cylindrical along its length or cylindrical along only a portion of its length with a graduated shape such as a smaller diameter cylindrical portion or an end portion which is tapered or conical. Preferably, the tip 120 tapers down from a proximal end 122 to a distal end 124. A bullet-shaped end may also be used wherein the cross-section in the longitudinal direction would appear parabolic. The shape may vary; however, it is preferred that the tip 120 mate with the type of introducer selected. The actual shape of the tip 120 should be determined by a number of factors, including but not limited to, ease of insertion and the shape of the passageway through a fitting into a proximal end of the introducer device into which the tip 120 is to be inserted.

[0036] The tip 120 further has an exterior surface 126 which may be smooth or rough. While not preferred, longitudinally extending gripping ribs (not shown) can be provided to extend along the surface 126 of the tip 120, particularly if the tip 120 is cylindrically shaped, or along a portion of the surface 126 of the tip 120. The exterior surface 126 of the tip 120 is preferably adapted to mate with an interior surface of the introducer device. For example, if the lumen in the proximal end of the introducer device were conically shaped, the exterior surface 126 of the tip 120 may be conically configured to more smoothly enter the lumen and to mate more securely with the introducer device.

[0037] With reference to Figs. 3 and 4, the distal portion 110 preferably has a generally rectangularly shaped portion 130 attached to the tip 120. The generally rectangularly shaped portion 130, as well as the entire distal portion 110, is preferably integrally molded as one piece. The generally rectangularly shaped portion 130 preferably extends transversely across the advancer 102 and has an inner surface 132 which faces the central portion 119. The passageway 114 terminates at the surface 132. When passing the guide wire 107 through the advancer 102 in a direction from the proximal end 116 to the distal end 118, the guide wire 107 would enter the distal end 118 through the terminal end of the passageway 114 at the surface 132.

[0038] Referring back to Fig. 3, the proximal end 116 of the advancer 102 has a passage 136 which extends longitudinally through the proximal end 116, which is sized to receive the guide wire 107 to facilitate insertion of the guide wire 107 through the advancer 102. In the embodiment shown, the passage 136 is axially aligned with the passageway 114 through the distal end 118, generally along the central longitudinal axis 112. While

such alignment is not necessary for the invention, it is preferred for ease of manufacture and to facilitate advancing of the guide wire 107 through the advancer 102. The proximal end 116 preferably has an inner end surface 138, shown in Figs. 3 and 4a, which faces, but is spaced from, the inner surface 132 of the distal end 118.

[0039] Now referring back to Fig. 2, the central portion 119 of the advancer 102 includes a pair of first and second longitudinally extending, preferably curved connecting members 150, 152, which interconnect the proximal and distal ends 116, 118. Preferably, the connecting members 150, 152 are flexible, for reasons that will be explained. The central portion 119 may be transversely spaced from and on opposing sides of the passageways 136, 114 through the proximal and distal ends 116, 118, respectively, and extend between the proximal end 116 and the distal end 118. Each connecting member 150, 152 is preferably generally arcuate such that an interior curved surface of each connecting member 150, 152 faces the central longitudinal axis 112. However, other shapes besides arcuate are envisioned and may be used within the scope of the invention. Such other shapes can include polygonal such as quadrilateral, hexagonal, octagonal as well as others not mentioned herein. The central portion 119 includes an opening 154 defined by a space between the curved surfaces of the connecting members 150, 152 for advancing the guide wire 107 through the advancer 102.

[0040] The opening 154 preferably provides access for the user to manipulate and advance the guide wire 107, preferably by gripping the wire 107 between a thumb and forefinger and feeding the wire 107 in a controllable manner. It is important is that the opening 154 between the members 150, 152 be configured to be sufficiently large so as to provide access to the physician to grip the guide wire 107 with the thumb and forefinger through the opening 154 at the central portion 119 to advance the guide wire 107 through the advancer 102.

[0041] The proximal portion 108 is shown in an enlarged perspective view of Fig. 3A. The proximal portion 108 includes a proximal end 160 and a distal end 162. A generally planar portion 164 extends between the proximal end 160 and the distal end 162. The distal end 162 of the proximal portion 108 includes a bulbous connector knob 166 extending along the longitudinal axis 112 to rotatably connect the proximal portion 108 and the distal portion 110 to each other (shown in Fig. 3), so that the proximal portion 108 and the distal portion 110 are able to rotate relative to each other about the longitudinal axis 112. The connector knob 166 extends through the passage 136 in the distal portion 110. During assembly of the advancer 102, the connector knob 166 is force fit through the passage 136 from the proximal end of the passage 136 to the distal end of the passage 136 so that the connector knob 166 extends into the opening 154.

[0042] The distal end 162 also includes a distal passageway 170 extending along the longitudinal axis 112. The distal passageway 170 is sized to allow the guide

wire 107 to slide easily through during guide wire insertion into the patient.

[0043] The proximal end 160 includes a male fitting 172 extending along the longitudinal axis 112. The male fitting 172 is configured to fit into an open end of the guide wire storage tube 104 (Figs. 1 and 2) and to engage the storage tube 104 with an interference fit so that the storage tube 104 will not slip from the proximal end 160. However, the fit between the storage tube 104 and the proximal end 160 should be loose enough to allow the storage tube 104 to easily rotate about the longitudinal axis-1 12, allowing the plane of the storage tube 104, as shown by the plane of the paper in Fig. 2, to rotate to facilitate handling by the physician during use. The male fitting 172 may be varied for different sized tubes. The male fitting 172 may also include a plurality of nubs 172a that extend away from the longitudinal axis 112 to further provide gripping strength to retain the male fitting 172 within the storage tube 104.

[0044] The proximal end 160 also includes a proximal passageway 174 extending along the longitudinal axis 112. The proximal passageway 174 is sized to allow the guide wire 107 to slide easily through during guide wire insertion into the patient.

[0045] The generally planar portion 164 extends below the longitudinal axis 112, as shown in Fig. 3A. The generally planar portion 164 includes a raised convex portion 176 that extends from the generally planar portion toward the longitudinal axis 112. The raised convex portion 176 may optionally include a generally oblong cutout 177 that extends generally along the longitudinal axis 112 to ensure that the guide wire 107 enjoys relatively free movement along the convex portion 176.

[0046] In the preferred embodiment, the invention further comprises an assembly 100 for feeding and straightening the guide wire 107 as shown in Figs. 1 and 2. The assembly 100 includes the advancer 102 connected to the guide wire storage tube 104. The guide wire 107 is enclosed within the storage tube 104, and the storage tube 104 can easily be held in place while the guide wire 107 is advanced forward into the patient. The storage tube 104 is preferably a flexible plastic tube which may be formed of any suitable polymeric material. Such tubes are well known in the art and are commercially available. The tube 104 has an open distal end 180 which connects to the proximal portion 108 of the advancer 102, preferably by coupling with the male fitting 172. The storage tube 104 may have one or more securing clips 184 which are typically sold with packaged storage tube coils. Such securing clips 184 help to retain the storage tube 104 in a coiled condition as seen in Figs. 1 and 2. The guide wire 107 extends longitudinally, and preferably loosely, within the storage tube 104. The proximal end 182 of the storage tube 104 may be equipped with couplings or a sealing cap (not shown) for preventing the guide wire 107 from advancing in the proximal direction out the proximal end 182 of the storage tube 104. While a storage tube 104 is preferred, a bare coil of guide wire 107 may also

be inserted directly into the proximal portion 108 of the advancer 102 without any structure directing the wire 107 into the advancer 102. However, the guide wire storage tube 104 improves handling of the coiled guide wire 107 and helps to prevent contamination and to maintain the guide wire 107 in a sterile condition. When the guide wire 107 is fully within the advancer 102 such that the guide wire 107 extends through the distal portion 114 from the storage tube 104, the guide wire 107 preferably extends across the central portion 119 such that the guide wire 107 is generally extends along the longitudinal axis 112.

[0047] The advancer 102 of the present invention may be made of any suitable material preferably capable of being sterilized, such as metals, metal alloys, polymeric and/or elastomeric materials. The material need not be biocompatible as the advancer 102 itself is not designed to enter the patient. In the preferred embodiment, for manufacturing economy and simplicity, the advancer 102 is made of a heat moldable or thermoformable polymeric or elastomeric material. The preferred polymeric, materials include thermoplastic or thermosetting polymers and copolymers, and more preferably, thermoplastic polymers which are capable of being injection molded or extruded. In the preferred embodiment, the proximal and distal portions 108, 110 of the advancer 102 are individually formed by injection molding using a mold having the desired configuration and using a rod or other means to maintain the longitudinally extending passageways 114, 136, 170, 174 through the distal and proximal portions 110, 108. In the preferred embodiment, the advancer 102 is formed of polyethylene, and even more preferably, polypropylene such as PP BSL PF 511 NT PRO-FAX® polypropylene sold by General Polymers. It is also within the scope of the invention to use reinforced polymeric or elastomeric or composite materials for forming the advancer with long or short fibrous reinforcements such as glass, carbon fiber, or polymeric fibers, fillers, or metal inserts or metallic wire mesh as well as any other suitable polymeric molding reinforcement. Pigments or other coloring agents may be added to the molding polymer to provide a bright or distinctive color to the advancer 102 for good visual identification during the guide wire insertion procedure.

[0048] The dimensions of the advancer 102 should be relatively small and sized to fit easily within the user's fingers while allowing a sufficiently long and wide central portion 119 for achieving adequate gripping and feeding movement using the thumb and preferably the forefinger. The size and shape of the opening 154, within the parameters as discussed above, should allow thumb and forefinger access to, and movement of the particular guide wire 107 through, the advancer 102. The tip 120 can similarly be sized for fitting easily into the proximal end of the guide wire introducer device for directing the guide wire 107 from the advancer 102 into the patient. Preferably, the overall length of the advancer 102 from the distal end of the tip 120 to the proximal end 160 of the proximal portion 108 is about 100 mm.

[0049] The wire 107 should advance through with an easy advancing motion, but should not interfere with the physician feeling any obstruction within the patient during the feeding operation as described further below. Preferably, some tactile control between the wire 107 and the physician's thumb and forefinger is preferred. Preferably, a distal tip 107a of the guide wire 107 is curved, as shown in Figs. 1 and 2. The tip 107a is curved to prevent the tip 107a from catching and perforating the vessel as the guide wire 107 is being passed through the lumen of a vessel in the patient P (see Fig. 5).

[0050] While the preferred embodiment of the guide wire advancer 102 disclosed above includes the proximal portion 108 disposed proximally of the distal portion 110, those skilled in the art will recognize that the portions may be rearranged such that the proximal portion 108 is disposed distally of the distal portion 110, without departing from the scope and intent of the present invention.

[0051] The present invention further includes a method for advancing and straightening the guide wire 107 for insertion into the patient, preferably using an apparatus such as the advancer assembly 100 as described above. However, those skilled in the art will realize that the advancer 102 can be used alone, without the storage tube 104. Typically, the vessel to be catheterized is located and cannulated by aspirating the vessel with the introducer device. After the vessel is aspirated, guide wire 107 is inserted into the vessel through the lumen of the introducer device according to one of the methods described below.

[0052] Figure 5 shows the advancer 102 having been inserted in the proximal end of an introducer device 200. The introducer device 200 generally includes a lumen 202 connected to a Luer lock connector 204, which has been disconnected from a mating fitting on an aspirating syringe (not shown).

[0053] Referring to Figs. 5 and 6, it is preferred that the introducer 102 be held along the central portion 119. Using one hand, the user's thumb and finger, preferably forefinger, are preferably used for the manipulation and feeding of the guide wire 107 through the central portion 119. Using the other hand, the user preferably holds on to the introducer device 200 to steady the introducer device 200. According to one preferred method, the tip 120 of the advancer 102 is inserted into the proximal end of the introducer device 200, which has already been inserted into the patient, as shown in Fig. 5. Preferably the advancer 102 or the assembly 100 having the storage tube 104 and guide wire 107 as described in detail above, are used in the preferred method. The curved distal end 107a of the guide wire 107 is already extended from the distal end 118 of the distal portion 110 and must be straightened prior to being inserted into the lumen 202 of the introducer device 200. Once the tip 107a is inserted into the lumen 202, the user uses his/her thumb and finger, preferably the forefinger, to grasp and controllably feed the wire 107. The wire 107 is thus moved through the central portion 154, and pushed through and out of

the advancer 102 in the direction of arrow "B" in Fig. 6.

[0054] In an alternately preferred method, shown in Fig. 7, the user grasps the guide wire 107 and the advancer 102 in one hand, the introducer device 200 in the other hand, and compresses the opening 154 in the advancer 102 such that the inner end surface 138 of the proximal end 116 is advanced toward the inner end surface 130 of the distal end 118 in the direction of arrow "C" in Fig. 7. The connecting members 150, 152, because of their flexibility, easily deform to allow such movement. As the advancer 102 is compressed, the guide wire 107 is advanced into the patient. The physician then releases the guide wire 107 and the advancer 102. The guide wire 107, due to friction between the guide wire 107 and the patient, remains in place and the advancer 102, due to the flexibility of the connecting members 150, 152, returns to the uncompressed position. The physician can repeat the process until the guide wire 107 is advanced a desired length.

[0055] In another alternatively preferred method, shown in Fig. 8, the user grasps the introducer device 200 with one hand, and grasps the proximal portion 108 of the advancer 102 with the other hand. The user depresses the guide wire 107 against the convex portion 176 of the generally planar portion 164, preferably with the thumb, and urges the guide wire 107 distally, as shown by the arrow "D" in Fig. 8, so that the guide wire 107 advances into the introducer device 200. The user then removes his/her thumb from the guide wire 107 and repeats the process until the guide wire 107 is advanced a desired length.

[0056] In all three preferred methods disclosed above, as the guide wire 107 is advanced, the guide wire end 107a passes out the end of the introducer device 200. The introducer device 200 is typically already within a vessel or other area to be catheterized in a patient (not shown) which will further hold the end 107a of the guide wire 107 straight when the end 107a of the guide wire 107 passes distally out of the introducer device 200. Therefore, when the end 107a of the guide wire 107 passes through the distal end of the introducer device 200, the end 107a is still straight and may pass directly into the patient in the area to be catheterized such as a blood vessel, a body cavity, or other area to be catheterized. The introducer device keeps the tip 107a of the guide wire 107 straight until the tip 107a exits the distal end of the introducer device 200 in the patient's body where the tip 107a can curl back to its natural, curved position.

[0057] According to any of the above-described methods, once the guide wire 107 is properly located within the patient, the storage tube 104, the advancer 102, and the introducer device 200 may each be removed from the proximal end of the guide wire 107. The introducer device 200 may in some cases be retained on the patient depending upon the procedure. The guide wire 107 is retained in the patient with the distal end 107a in the area to be catheterized, and the proximal end outside the patient. The catheter or other cannula is introduced into the

patient by passing a catheter over the guide wire 107 in accordance with standard medical procedures.

[0058] Preferably, the apparatus used in the present method is the advancer 102 or the assembly 100. However, it should be understood, based on this disclosure, that other similar advancing devices having suitable tips and exterior gripping surfaces which are capable of carrying out the steps of the preferred method as described herein and allowing access to the thumb and a finger for controllably advancing the guide wire 107 by feeding may be used.

Claims

1. A guide wire advancer (102) having a body having a longitudinal axis (112), wherein the body comprises a first portion (110) adapted to allow a user to advance a guide wire (107) along the longitudinal axis using a finger and a thumb to directly frictionally engage the guide wire therebetween;

characterized in that

the body further comprises a second portion (108) connected to the first portion (110), wherein the second portion is adapted to allow a user to advance the guide wire (107) along the longitudinal axis using only one of the finger and the thumb to directly frictionally engage the guide wire, with the second portion (108) defining a guide wire platform (164) that exposes the guide wire and against which the finger or thumb biases the guide wire while urging the guide wire forwardly therealong.

2. The guide wire advancer (102) according to claim 1, wherein the first portion (110) and the second portion (108) are independently rotatable about the longitudinal axis (112).
3. The guide wire advancer (102) according to claim 1, wherein the more distal of the first (110) and second (108) portions concludes in a distal tip (120) adapted to cooperate with an introducer to enable the guide wire (107) to directly enter the introducer and then into the patient when advanced.
4. The guide wire advancer (102) according to claim 1, wherein the distal tip (120) is frustoconical.
5. The guide wire advancer according to claim 1, wherein the first portion (110) is disposed distally of the second portion (108).
6. The guide wire advancer (102) according to claim 1, wherein the first portion (110) comprises:

a distal portion (110) having a first passageway (114) extending longitudinally therethrough;
a proximal portion (116) having a second pas-

- sageway (136) extending longitudinally there-through; and
 a central portion (119) having first and second members (150,152) extending between the distal portion and the proximal portion, wherein the first and second members define an opening (154) therebetween within which the guide wire (107) would be exposed for manual engagement when extending from the proximal portion (116) to the distal portion (110).
7. The guide wire advancer (102) according to claim 6, wherein the distal passageway (114) is adapted to frictionally engage the guide wire (107), and wherein compression of the opening (154) by deformation of the first and second members (150,152) moves the proximal portion (116) toward the distal portion (110) to advance the guide wire through the first and second passageways (114,136).
8. The guide wire advancer (102) according to claim 6, wherein the first and second members (150,152) are arcuate.
9. The guide wire advancer (102) according to claim 6, wherein the opening (154) is sufficiently large to enable the finger and the thumb to grasp a guide wire (107) extending through the opening and advance the guide wire along the first and second passageways (114,136).
10. The guide wire advancer (102) according to claim 1, wherein the second portion (108) comprises a distal portion (162) having a first passageway (170) extending longitudinally therethrough, a proximal portion (160) having a second passageway (174) extending longitudinally therethrough, and wherein the platform (164) is elongated and connects the proximal portion and the distal portion and is disposed on one side of the longitudinal axis (112),
11. The guide wire advancer (102) according to claim 1, wherein the platform (164) includes a raised convex portion (176) having a shallow cutout (177) thereacross aligned with the longitudinal axis in which the guide wire (107) is disposed.
12. A guide wire advancer assembly (100) comprising:
 a guide wire advancer (102) as set forth in any of claims 1 to 11;
 a guide wire storage tube (104) connected to a proximal end of the body; and
 a guide wire (107) disposed at least partially within the guide wire storage tube.

Patentansprüche

1. Ein Führungsdrahtvorschieber (102) mit einem, eine Längsachse (112) aufweisenden Körper, wobei der Körper einen ersten Bereich (110) umfasst, der dazu eingerichtet ist, einem Anwender das Vorschieben eines Führungsdrahts (107) entlang der Längsachse unter Verwendung eines Fingers und eines Daumens zum direkt reibenden Erfassen des Führungsdrahts dazwischen, zu ermöglichen;
dadurch gekennzeichnet, dass
 der Körper weiters einen zweiten Bereich (108) umfasst, der mit dem ersten Bereich (110) verbunden ist, wobei der zweite Bereich dazu eingerichtet ist, einem Anwender das Vorschieben des Führungsdrahts (107) entlang der Längsachse unter Verwendung von lediglich des Fingers oder des Daumens zum direkt reibenden Erfassen des Führungsdrahts zu ermöglichen, mit dem zweiten Bereich (108), der eine Führungsdrahtplattform (164) definiert, welche den Führungsdraht freilegt und gegen welche der Finger oder der Daumen den Führungsdraht während dem Vorwärtstreiben des Führungsdrahtes dort entlang spannt.
2. Der Führungsdrahtvorschieber (102) nach Anspruch 1, wobei der erste Bereich (110) und der zweite Bereich (108) in unabhängiger Weise um die Längsachse (112) drehbar sind.
3. Der Führungsdrahtvorschieber (102) nach Anspruch 1, wobei das distalere der ersten (110) und zweiten (108) Bereiche in einer distalen Spitze (120) endet, welche dazu eingerichtet ist, mit einer Einführeinrichtung zusammenzuwirken, um dem Führungsdraht (107) das direkte Eintreten in die Einführeinrichtung und, wenn vorgeschoben, anschließend in den Patienten zu ermöglichen.
4. Der Führungsdrahtvorschieber (102) nach Anspruch 1, wobei die distale Spitze (120) kegelförmig ist.
5. Der Führungsdrahtvorschieber nach Anspruch 1, wobei der erste Bereich (110) distal vom zweiten Bereich (108) angeordnet ist.
6. Der Führungsdrahtvorschieber (102) nach Anspruch 1, wobei der erste Bereich (110) aufweist:
 einen distalen Bereich (110) mit einem ersten sich längs hindurch erstreckenden Durchgang (114);
 einen proximalen Bereich (116) mit einem zweiten sich längs hindurch erstreckenden Durchgang (136); und
 einen mittleren Bereich (119) mit ersten und zweiten sich zwischen dem distalen Bereich und

- dem proximalen Bereich erstreckenden Elementen (150,152), wobei die ersten und zweiten Elemente eine dazwischen liegende Öffnung (154) definieren, in welcher der Führungsdraht (107) zum manuellen Erfassen, wenn er sich vom proximalen Bereich (116) zum distalen Bereich (110) erstreckt, freigelegt wäre.
7. Der Führungsdrahtvorschieber (102) nach Anspruch 6, wobei der distale Durchgang (114) dazu eingerichtet ist, den Führungsdraht (107) direkt reibend zu erfassen, und wobei das Zusammendrücken der Öffnung (154) durch Deformation der ersten und zweiten Elemente (150,152) zum Vorschieben des Führungsdrahts durch die ersten und zweiten Durchgänge (114,136) den proximalen Bereich (116) gegen den distalen Bereich (110) bewegt.
8. Der Führungsdrahtvorschieber (102) nach Anspruch 6, wobei die ersten und zweiten Elemente (150,152) bogenförmig sind.
9. Der Führungsdrahtvorschieber (102) nach Anspruch 6, wobei die Öffnung (154) ausreichend groß ist, um dem Finger oder dem Daumen das Erfassen des Führungsdrahts (107), der sich durch die Öffnung erstreckt, und das Vorschieben des Führungsdrahts entlang der ersten und zweiten Durchgänge (114,136) zu ermöglichen.
10. Der Führungsdrahtvorschieber (102) nach Anspruch 1, wobei der zweite Bereich (108) einen distalen Bereich (162) mit einem ersten sich längs hindurch erstreckenden Durchgang (170) umfasst, einen proximalen Bereich (160) mit einem zweiten sich längs hindurch erstreckenden Durchgang (164), und wobei die Plattform (164) länglich ist und den proximalen Bereich und den distalen Bereich verbindet und auf einer Seite der Längsachse (112) angeordnet ist.
11. Der Führungsdrahtvorschieber (102) nach Anspruch 1, wobei die Plattform (164) einen erhöhten konvexen Bereich (176) mit einem darauf verlaufenden flachen Ausschnitt (177), der an der Längsachse ausgerichtet ist, in welcher der Führungsdraht (107) angeordnet ist, einschließt.
12. Eine Führungsdrahtvorschiebeanordnung (100) aufweisend:
- einen Führungsdrahtvorschieber (102) nach einem der Ansprüche 1 bis 11;
- einen Führungsdrahtlagerschlauch (104), der mit einem proximalen Ende des Körper verbunden ist; und
- einem Führungsdraht (107), der zumindest teilweise im Führungsdrahtlagerschlauch ange-

ordnet ist.

Revendications

1. Dispositif d'avance de fil de guidage (102) comportant un corps qui a un axe longitudinal (112), dans lequel le corps comprend une première partie (110) adaptée pour permettre à un utilisateur d'avancer un fil de guidage (107) le long de l'axe longitudinal en utilisant un doigt et un pouce pour venir en prise directement par frottement avec le fil de guidage entre eux ;
- caractérisé en ce que**
- le corps comprend en outre une deuxième partie (108) reliée à la première partie (110), dans lequel la deuxième partie est adaptée pour permettre à un utilisateur d'avancer le fil de guidage (107) le long de l'axe longitudinal en utilisant uniquement le doigt et le pouce pour venir en prise directement par frottement avec le fil de guidage, la deuxième partie (108) définissant une plateforme de fil de guidage (164) qui expose le fil de guidage et contre laquelle le doigt ou le pouce applique le fil de guidage tout en poussant le fil de guidage vers l'avant le long de celle-ci.
2. Dispositif d'avance de fil de guidage (102) selon la revendication 1, dans lequel la première partie (110) et la deuxième partie (108) sont capables de tourner de manière indépendante autour de l'axe longitudinal (112).
3. Dispositif d'avance de fil de guidage (102) selon la revendication 1, dans lequel la plus éloignée de la première (110) et de la deuxième (108) partie aboutit dans un bout distal (120) adapté pour coopérer avec un dispositif d'introduction pour permettre au fil de guidage (107) d'entrer directement dans le dispositif d'introduction et ensuite dans le patient lorsqu'il est avancé.
4. Dispositif d'avance de fil de guidage (102) selon la revendication 1, dans lequel le bout distal (120) est conique tronqué.
5. Dispositif d'avance de fil de guidage selon la revendication 1, dans lequel la première partie (110) est disposée à distance de la deuxième partie (108).
6. Dispositif d'avance de fil de guidage (102) selon la revendication 1, dans lequel la première partie (110) comprend :
- une partie distale (110) comportant un premier passage (114) s'étendant longitudinalement à travers celle-ci ;
- une partie proximale (116) comportant un

- deuxième passage (136) s'étendant longitudinalement à travers celle-ci ; et
 une partie centrale (119) comportant des premier et deuxième éléments (150, 152) s'étendant entre la partie distale et la partie proximale, dans lequel les premier et deuxième éléments définissent une ouverture (154) entre eux dans laquelle le fil de guidage (107) serait exposé pour une mise en prise manuelle lorsqu'il s'étend de la partie proximale (116) jusqu'à la partie distale (110).
- 5
- 10
7. Dispositif d'avance de fil de guidage (102) selon la revendication 6, dans lequel le passage distal (114) est adapté pour venir en prise par frottement avec le fil de guidage (107), et dans lequel la compression de l'ouverture (154) par déformation des premier et deuxième éléments (150, 152) déplace la partie proximale (116) vers la partie distale (110) pour avancer le fil de guidage à travers les premier et deuxième passages (114, 136).
- 15
- 20
8. Dispositif d'avance de fil de guidage (102) selon la revendication 6, dans lequel les premier et deuxième éléments (150, 152) sont en forme d'arc.
- 25
9. Dispositif d'avance de fil de guidage (102) selon la revendication 6, dans lequel l'ouverture (154) est suffisamment grande pour permettre au doigt et au pouce de saisir un fil de guidage (107) s'étendant à travers l'ouverture et d'avancer le fil de guidage le long des premier et deuxième passages (114, 136).
- 30
10. Dispositif d'avance de fil de guidage (102) selon la revendication 1, dans lequel la deuxième partie (108) comprend une partie distale (162) comportant un premier passage (170) s'étendant longitudinalement à travers celle-ci, une partie proximale (160) comportant un deuxième passage (174) s'étendant longitudinalement à travers celle-ci, et dans lequel la plateforme (164) est allongée et relie la partie proximale et la partie distale et est disposée d'un côté de l'axe longitudinal (112).
- 35
- 40
11. Dispositif d'avance de fil de guidage (102) selon la revendication 1, dans lequel la plateforme (164) comprend une partie convexe (176) surélevée comportant une découpe (177) peu profonde en travers de celle-ci alignée avec l'axe longitudinal dans laquelle le fil de guidage (107) est disposé.
- 45
- 50
12. Ensemble d'avance de fil de guidage (100) comprenant :
- un dispositif d'avance de fil de guidage (102) selon l'une quelconque des revendications 1 à 11 ;
 un tube de stockage de fil de guidage (104) relié
- 55
- à une extrémité proximale du corps ; et
 un fil de guidage (107) disposé au moins partiellement dans le tube de stockage de fil de guidage.

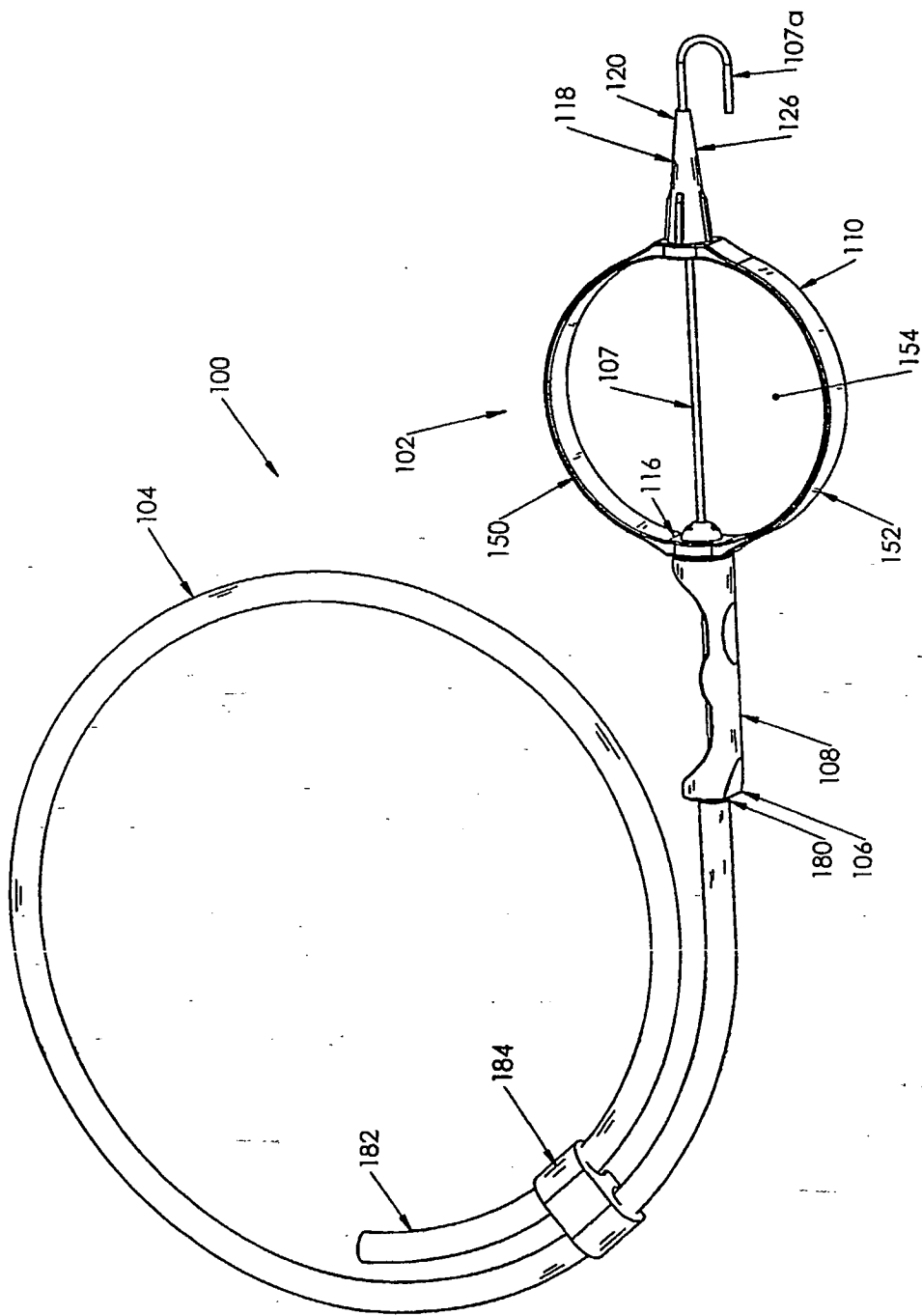

FIG. 1

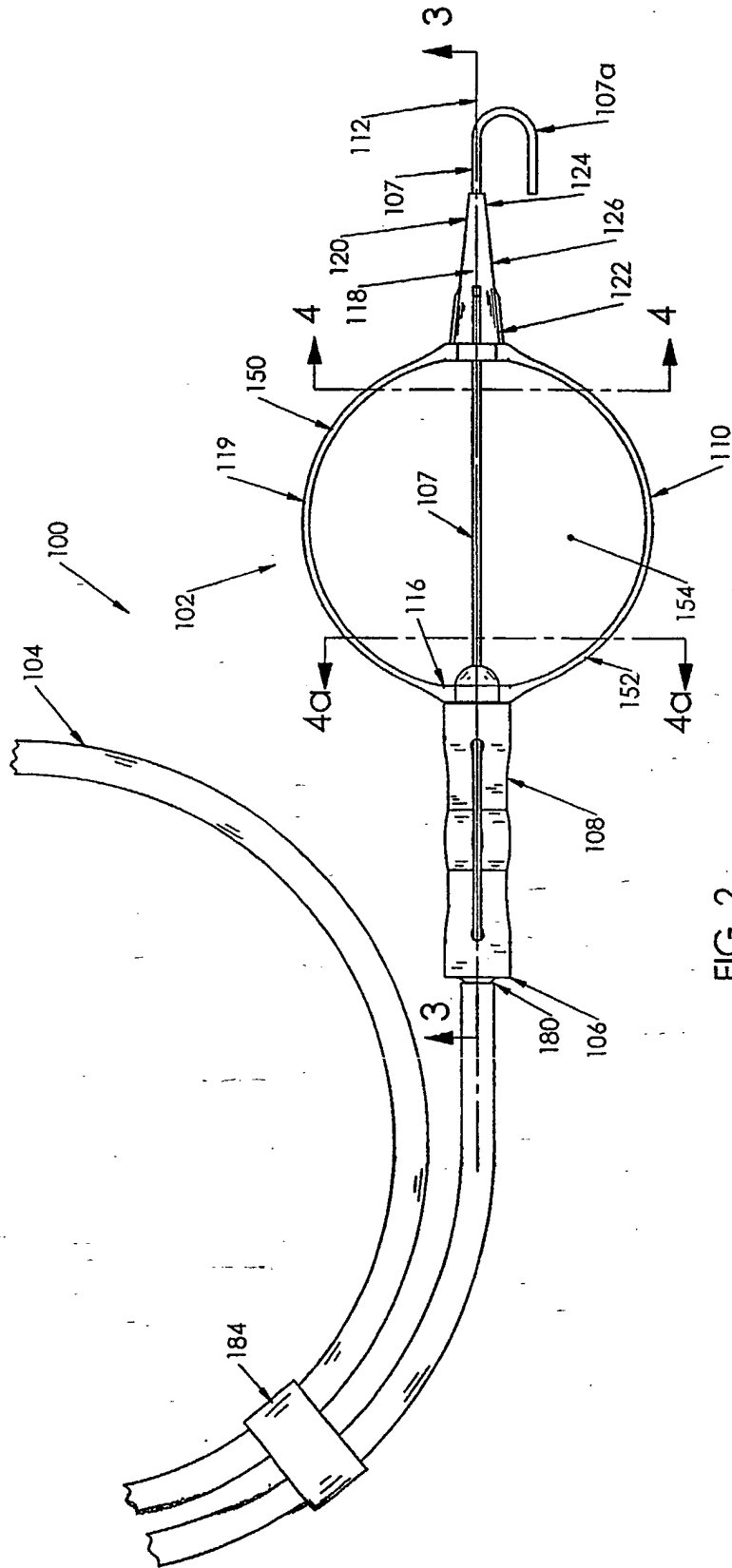

FIG. 2

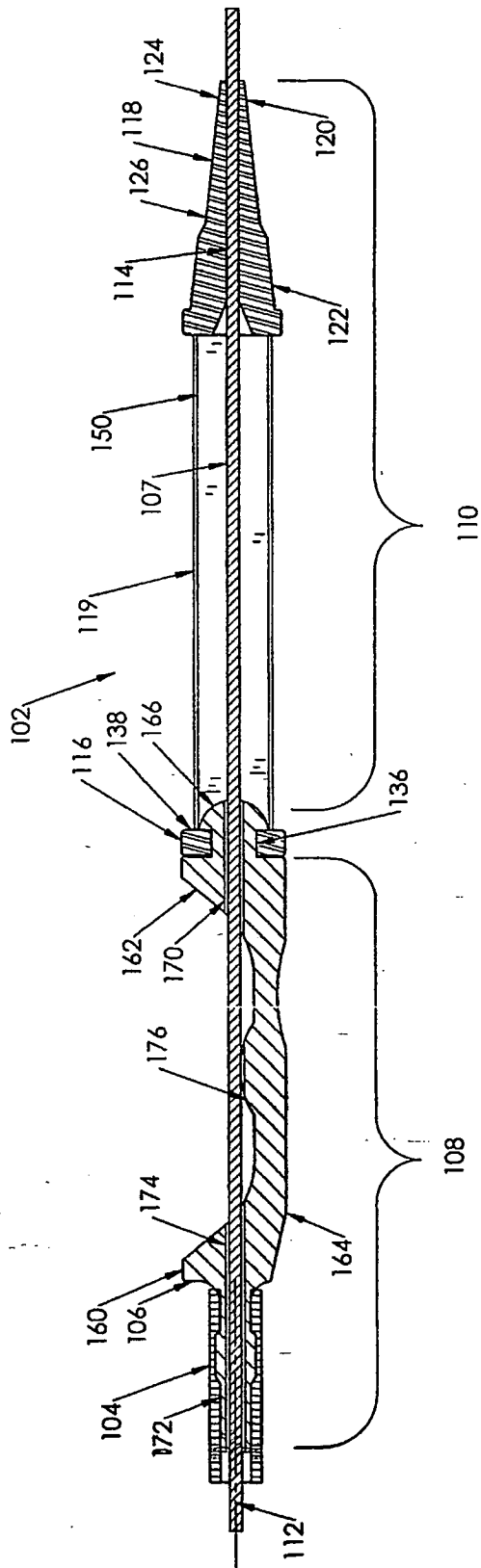

FIG. 3

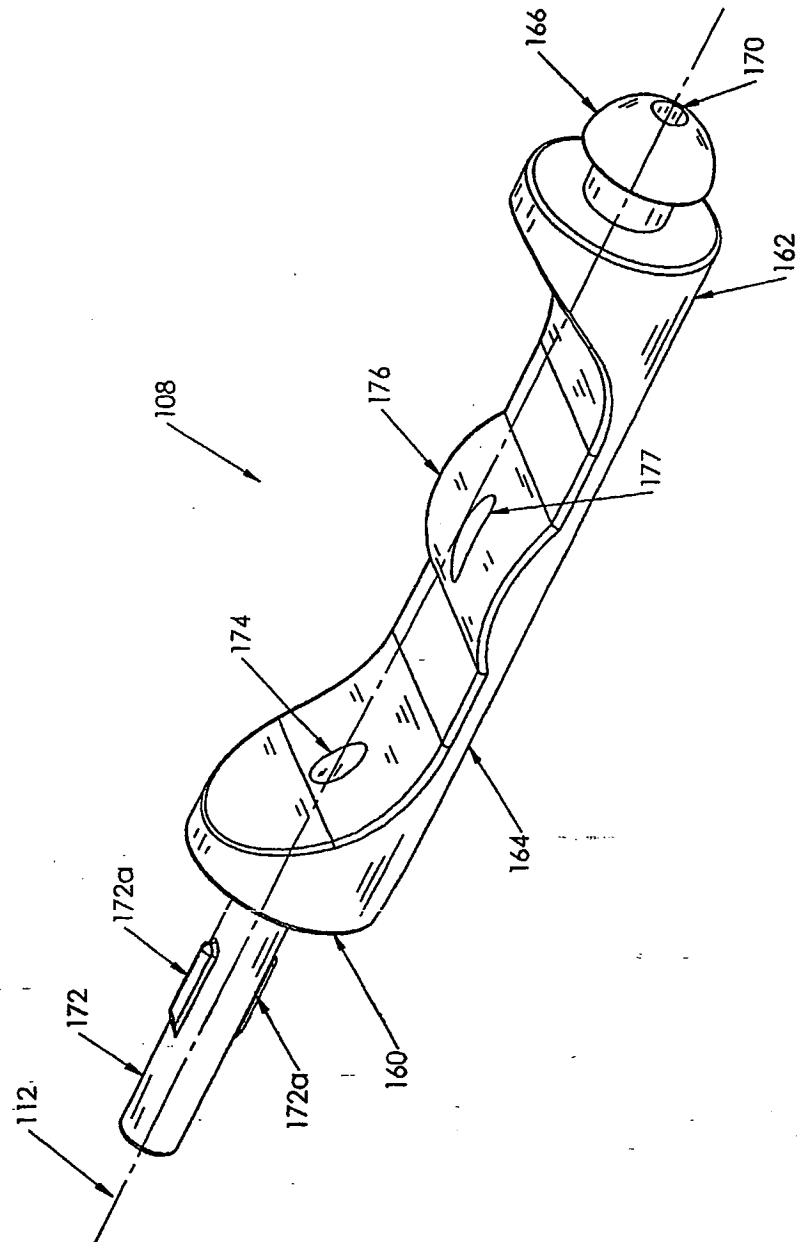

FIG. 3A

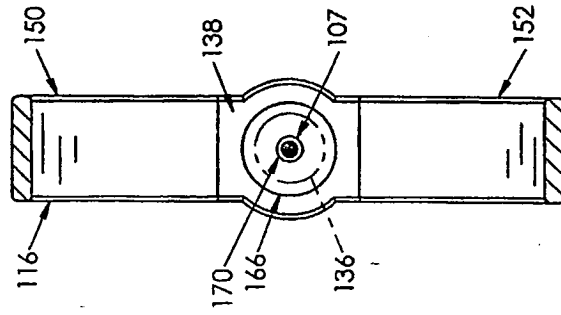

FIG. 4a

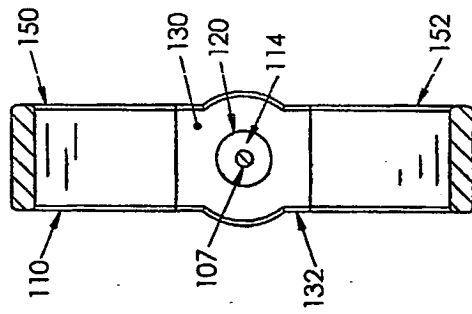

FIG. 4

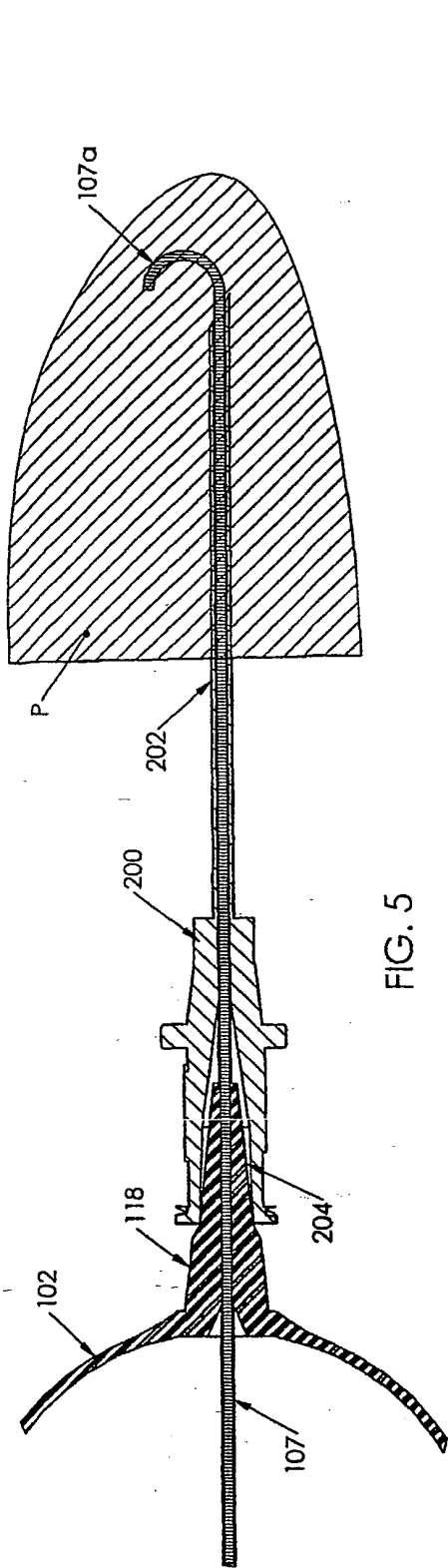

FIG. 5

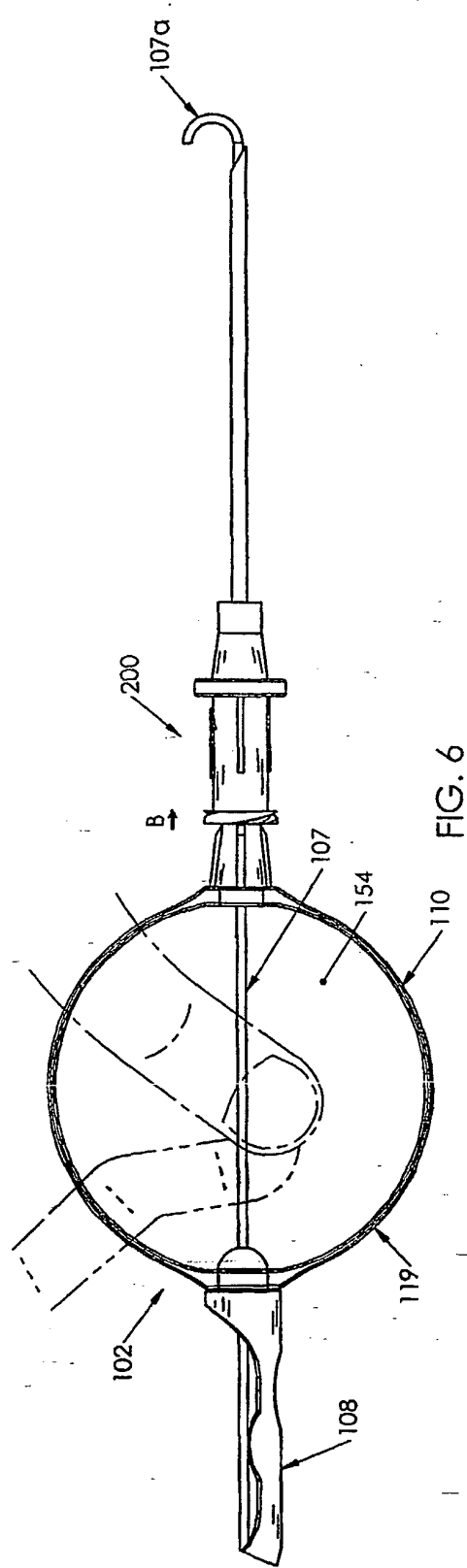

FIG. 6

REFERENCES CITED IN THE DESCRIPTION

This list of references cited by the applicant is for the reader's convenience only. It does not form part of the European patent document. Even though great care has been taken in compiling the references, errors or omissions cannot be excluded and the EPO disclaims all liability in this regard.

Patent documents cited in the description

- US 60649310 B [0001]
- US 4713059 A [0007]
- US 4274408 A [0008]
- US 4417886 A [0008]
- US 4813938 A [0008]
- US 5045065 A [0008]
- US 5125906 A [0009]
- US 5484419 A [0009]
- US 5507300 A [0010]
- US 5366444 A [0011]
- US 4860757 A [0012]
- US 4917094 A [0012]
- US 5273042 A [0012]
- US 5438993 A [0012]
- US 5448993 A [0012]
- US 6551281 B [0013]
- US 6277100 B [0034]

专利名称(译)	导丝推进器组件		
公开(公告)号	EP1845872B1	公开(公告)日	2010-10-27
申请号	EP2006748180	申请日	2006-02-01
[标]申请(专利权)人(译)	RAULERSON J DANIEL SCHWEIKERT TIMOTHY 中号		
申请(专利权)人(译)	医疗元件, INC. RAULERSON, 丹尼尔J. SCHWEIKERT, TIMOTHY M.		
当前申请(专利权)人(译)	医疗元件, INC. RAULERSON, 丹尼尔J. SCHWEIKERT, TIMOTHY M.		
[标]发明人	RAULERSON J DANIEL SCHWEIKERT TIMOTHY M		
发明人	RAULERSON, J. DANIEL SCHWEIKERT, TIMOTHY M.		
IPC分类号	A61B5/00 A61M25/00 A61M1/06 A61M31/00 A61M37/00 A61M5/178 A61M5/315 A61F11/00		
CPC分类号	A61B5/00 A61M25/00 A61M25/0041 A61M25/0105 A61M25/0113 A61M25/09 A61M25/09041		
优先权	60/649310 2005-02-02 US		
其他公开文献	EP1845872A4 EP1845872A2		
外部链接	Espacenet		

摘要(译)

一种导丝推进器 (102), 用于将导丝 (107) 推进患者体内, 并包括具有纵轴的主体。主体包括第一部分 (110), 其适于允许用户使用手指和拇指沿着纵向轴线推进导丝, 以及连接到第一部分的第二部分 (108)。第二部分 (108) 适于允许使用者仅使用一个手指或拇指沿着纵向轴线推进导丝 (107), 以在推进导向装置时将导丝偏压在第二部分的平台 (164) 上电线 (107)。还公开了使用推进器推进导丝的多种方法。

