

(19)



(11)

EP 1 401 518 B2

(12)

NEW EUROPEAN PATENT SPECIFICATION

After opposition procedure

(45) Date of publication and mention of the opposition decision:
13.08.2014 Bulletin 2014/33

(51) Int Cl.:
A61M 5/168 ^(2006.01) **A61M 1/36** ^(2006.01)
A61B 5/00 ^(2006.01)

(45) Mention of the grant of the patent:
01.03.2006 Bulletin 2006/09

(86) International application number:
PCT/US2002/017019

(21) Application number: **02737267.1**

(87) International publication number:
WO 2003/000315 (03.01.2003 Gazette 2003/01)

(22) Date of filing: **30.05.2002**

(54) **NEEDLE DISLODGE MENT DETECTION**

DETEKTION EINER VERLAGERUNG DER NADEL

DETECTION DE DELOGEMENT D'AIGUILLE

(84) Designated Contracting States:
AT BE CH CY DE DK ES FI FR GB GR IE IT LI LU MC NL PT SE TR

• **CARO, Hector**
St. Petersburg, FL 33702 (US)

(30) Priority: **22.06.2001 US 888154**

(74) Representative: **Potter Clarkson LLP**
The Belgrave Centre
Talbot Street
Nottingham, NG1 5GG (GB)

(43) Date of publication of application:
31.03.2004 Bulletin 2004/14

(73) Proprietor: **Baxter International Inc.**
Deerfield, IL 60015 (US)

(56) References cited:
EP-A2- 1 263 488 WO-A-01/08729
WO-A-01/68163 WO-A-99/24145
WO-A-99/26686 WO-A-99/29356
WO-A1-97/10013 WO-A1-99/56614
DE-A- 3 911 812 DE-A- 19 953 068
DE-A1- 4 014 572 FR-A1- 2 737 124
US-A- 3 245 068 US-A- 3 782 377
US-A- 3 832 993 US-A- 3 900 026
US-A- 5 469 145 US-A- 5 507 288
US-A- 5 579 765 US-A- 5 779 657

(72) Inventors:
 • **WARIAR, Ramesh**
Tampa, FL 33626 (US)
 • **HARTRANFT, Thomas, P.**
Clearwater, FL 33761 (US)
 • **CAMERON, Norm**
St. Petersburg, FL 33714 (US)
 • **LASSO, Angel**
Tampa, FL 33626 (US)

EP 1 401 518 B2

Description

BACKGROUND OF THE INVENTION

[0001] The present invention relates to the detection of needle dislodgement during medical treatments or therapies, such as hemodialysis.

[0002] A variety of different medical treatments relate to removing blood from a patient. For example, hemodialysis treatment utilizes the patient's blood to remove waste, toxins and excess water from the patient. The patient is connected to a hemodialysis machine, and the patient's blood is pumped through the machine. Waste, toxins and excess water are removed from the patient's blood, and the blood is infused back into the patient. Needles are inserted into the patient's vascular access, such as arteries and veins, to transfer the patient's blood to and from the hemodialysis machine. Hemodialysis treatments can last several hours and are generally performed in a treatment center about three to four times per week.

[0003] During hemodialysis treatment, dislodgement of the needle inserted into the patient's vascular access, such as veins, can occur. If not detected immediately, this can produce a significant amount of blood loss to the hemodialysis patient. Two important criteria for detecting needle dislodgement are high sensitivity and specificity of the detection method with respect to needle dropout. This can ensure and facilitate a fast response time in order to minimize blood loss due to dislodgement.

[0004] Typically, patients undergoing hemodialysis are visually monitored in order to detect needle dislodgement. However, the needle may not be in plain view of the patient or medical staff such that it could delay responsive actions to dislodgement, such as stopping the blood pump of the hemodialysis machine.

[0005] Although devices which employ sensors are available and known for detecting a variety of different bodily fluids, these devices may not be suitably adapted to detect needle dislodgement. For example, known devices employing such sensors have been utilized to detect bedwetting and diaper wetness. However, these types of wetness detection devices may not provide an adequate level of sensitivity if applied to detecting blood loss from the patient due to needle dislodgement.

[0006] In this regard, the known wetness detection devices may not be able to detect needle drop out with sufficient enough sensitivity and specificity to ensure and facilitate a proper and fast response. Further, as applied to hemodialysis, known wetness detection devices may not be configured to be controllably interfaced, or at least not properly interfaced, with, for example, a hemodialysis machine such that a responsive measure can be taken to minimize blood flow due to needle dislodgement once detected. In addition, a number of known wetness detectors are not reusable, or at least must be cleaned after each use, due to the fact that the sensor component contacts fluid when detecting same. This can require exten-

sive cleaning of the sensor, particularly if it has contacted blood, in order to minimize the risk of infection prior to reuse.

[0007] WO 99/24145 describes a fluid sensing device (11) that includes a pair of electrodes (A, B) which are placed on the surface of a patient's body (8) adjacent to a needle, (15, 19) inserted into the patient. The electrodes are connected to a computer and an alarm circuit and when they detect the leakage of blood due to a needle dislodgement they send a signal to the computer and the alarm circuit which deactivate a blood pump and activate an alarm.

[0008] WO 99/29356 describes a device for monitoring fluid supply to an implanted catheter. The device comprises an electrode (10) placed on the skin of the patient. The liquid flow may be determined based on the electrical resistance between the electrode and at least one other electrical contact (P, Q).

[0009] WO 01/68163 describes an infusion leak detection system which includes a pad (28) positioned adjacent to the infusion site of the needle. The pad secures a delivery device, such as an infusion set or pump, to the patient's skin. FR-2,737,124, US-5,779,657, US-3,245,068 and WO 99/33037 disclose devices for detecting blood leaks which use a sensor that contacts the blood. Some of these documents disclose an apparatus according to the preamble of claim 1. US-5,903,222 discloses a wet garment detector that uses a non-contact capacitive sensor.

[0010] Accordingly, efforts have been directed at designing devices for detecting needle dislodgement wherein detection is sensitive and specific to needle drop out or dislodgement such that responsive measures can be suitably taken to minimize blood loss from the patient due to needle dislodgement.

SUMMARY OF THE INVENTION

[0011] The present invention provides improved apparatuses and a method for detecting needle dislodgement. In this regard, the present invention provides improved apparatuses that employ a sensor capable of detecting wetness due to blood loss from a patient resulting from needle dislodgement.

[0012] According to the present invention there is provided an apparatus and method for detecting dislodgement of a needle according to claims 1 and 10.

[0013] The sensor comprises a capacitive sensor.

[0014] In an embodiment, the capacitive sensor includes one or more electrodes.

[0015] The capacitive sensor is located within the sensor holder such that the sensor does not contact blood upon detection thereof.

[0016] In an embodiment, the sensor produces a signal upon detection of blood loss.

[0017] In an embodiment, the apparatus further includes a control device adapted to receive the signal for monitoring and controlling blood loss due to dislodgement.

ment of the needle during hemodialysis.

[0018] The absorbent pad provides a sterile barrier.

[0019] In another embodiment, the apparatus is used for detecting needle dislodgement during hemodialysis and comprises a sensor holder having a cavity; and a capacitive sensor including an electrode enclosed within the cavity of the sensor holder such that the capacitive sensor is capable of detecting wetness from blood due to needle dislodgement during hemodialysis wherein the capacitive sensor does not contact blood upon detection thereof, and the capacitive sensor detects wetness due to blood loss into a sterile pad overlying a vascular access region of a venous needle.

[0020] In an embodiment, the sensor holder includes a flexible material that adaptedly conforms to the vascular access region such that the capacitive sensor is capable of detecting blood loss due to needle dislodgement.

[0021] In another embodiment, the apparatus can be used to control blood loss from a patient during hemodialysis and comprises a sensor capable of detecting wetness due to blood and a sensor holder adapted to secure the sensor to the patient. The sensor produces a signal indicative of wetness due to blood loss from the patient upon dislodgement of a venous needle inserted into the patient and the apparatus further comprises a controller capable of processing the signal to prevent blood flow through the venous needle such that blood loss from the patient due to dislodgement of the venous needle is minimized.

[0022] In an embodiment, the controller is in communication with a hemodialysis machine via an electrical communication cable or a cordless interface to minimize blood loss due to venous needle dislodgement.

[0023] In an embodiment, the controller is adapted to monitor one or more hemodialysis treatment parameters including wetness due to blood loss, change in blood flow, detection of the arterial air bubbles or combinations thereof.

[0024] In an embodiment, the controller comprises a display for monitoring each of the hemodialysis treatment parameters.

[0025] In an embodiment, the controller is attached to the patient. The apparatus may be used for controlling blood loss from a patient due to needle dislodgement. In this application, the sensor is secured to the patient adjacent the needle such that the sensor produces a signal indicative of wetness due to blood loss from the patient upon dislodgement of the needle. The signal is processed to prevent blood flow through the venous needle such that blood loss to the patient due to needle dislodgement is minimized.

[0026] In an embodiment, the signal is processed for communicating with a hemodialysis machine to minimize blood loss to the patient due to needle dislodgement.

[0027] In an embodiment, the signal is processed to shut-off a blood pump of the hemodialysis machine.

[0028] In an embodiment, the signal is processed to activate a venous line clamp for preventing blood flow

via the venous needle.

[0029] In an embodiment, blood flow through the venous needle is stopped upon detecting dislodgement of the venous needle such that blood loss from the patient is minimized.

[0030] An advantage of the present invention is to provide an improved apparatus for detecting needle dislodgement.

[0031] A further advantage of the present invention is to provide an improved method for detecting needle dislodgement.

[0032] Still further, an advantage of the present invention is to provide an apparatus that employs a sensor which does not contact blood upon detection thereof.

[0033] Furthermore, an advantage of the present invention is to provide an improved apparatus for monitoring and/or controlling blood loss from a patient due to needle dislodgement.

BRIEF DESCRIPTION OF THE FIGURES

[0034]

Figure 1 illustrates a perspective view of a comparative apparatus not claimed for detecting needle dislodgement.

Figure 2A illustrates a resistive sensor not claimed. Figure 2B illustrates an embodiment of a capacitive sensor.

Figures 3A to 3C illustrate an embodiment of an apparatus for detecting needle dislodgement of the present invention showing a sensor holder and a sensor located inside of the sensor holder. Figure 3A illustrates a top perspective view. Figure 3B illustrates an exploded view. Figure 3C illustrates a side sectional view.

DETAILED DESCRIPTION OF THE INVENTION

[0035] The present invention provides apparatuses and a method for detecting needle dislodgement. More specifically, the present invention provides apparatuses and methods that employ a sensor to detect needle dislodgement such that blood loss due to dislodgement can be controllably minimized.

[0036] Although in the embodiment set forth below the apparatus is designed for use in hemodialysis, it should be noted that the apparatus can be used in a number of different therapies. In this regard, the apparatus can be used in non-traditional hemodialysis methods. Such methods include, for example, regeneration and continuous flow therapies which may or may not include hemodialysis, for example, continuous flow peritoneal dialysis. Further, although the present apparatus can be utilized in methods providing dialysis for patients having chronic kidney failure or disease, it can be used for acute dialysis needs, for example, in an emergency room setting.

[0037] In general, the apparatus for detecting needle dislodgement of the present invention includes a sensor that is capable of detecting wetness due to blood and a sensor holder that is adapted to secure the sensor to a patient such that the apparatus can effectively detect dislodgement of the needle during treatment or therapy. For example, during hemodialysis, dislodgement of a venous needle can occur. If dislodged, a significant amount of blood loss can occur within a relatively short period of time. In this regard, the sensor of the apparatus of the present invention can detect wetness due to blood loss from the patient resulting from the dislodged needle. The detection of blood loss is an indication that the needle has become dislodged. Thus, needle dislodgement can be detected.

[0038] Applicants have surprisingly found that the apparatus of the present invention can detect needle dislodgement, particularly venous needle dislodgement, with high sensitivity and specificity. In this regard, the apparatus of the present invention can be utilized to controllably minimize blood loss from the patient due to the dislodged needle.

[0039] It should be appreciated that the apparatus of the present invention can include a variety of different configurations and other components in addition to the sensor and sensor holder depending on the application of the detection apparatus. It should further be appreciated that the various components of the apparatus can include a variety of different and suitably known materials such that needle dislodgement can be effectively and immediately detected to minimize blood loss from the patient due to dislodgement of the needle.

[0040] Referring now to Figure 1, the comparative arrangement includes a sensor 10 and sensor holder 12 that overlies the sensor 10 such that sensor holder 12 secures the sensor 10 to the patient 14 for detecting wetness due to blood loss from the patient 14 upon dislodgement of the needle 16. In the comparative arrangement, the sensor holder 12 includes a pad configuration such that it is sized to cover the needle 16 and access region 18 therein.

[0041] In the comparative arrangement, the sensor holder 12 includes a rigid material, such as a rigid plastic material, that has a preferable dome shape. In this regard, the sensor holder 12 can act to shield and protect the sensor 10, needle 16 and other components that it covers in addition to properly positioning and securing the sensor 10 over the access or insertion region 18 of the needle 16.

[0042] In the comparative arrangement, the apparatus can include a sterile barrier 20 overlying the access region 18 between the sensor 10 and needle 16 as shown in Figure 1. The sterile barrier 20 or pad can include a variety of different medically sterile materials, such as gauze pads, BAND-AIDS or the like. If a gauze pad or typical absorbent pad is used, the sensor 10 can be positioned to contact the absorbent pad. In this position, the sensor 10 can contact blood that is absorbed by the

absorbent pad due to a blood loss from the patient 14. The sensor 10 can then detect the presence of blood in the absorbent pad.

[0043] In an embodiment, the capacitive sensor 34 can include one or more electrodes for detection purposes. As illustrated in Figure 2B, the capacitive sensor 34 includes two electrodes 36,38 each made from a known copper material. The electrodes 36,38 can be arranged in any suitable fashion, preferably in an interwoven configuration as shown in Figure 2B. In this regard, a change in the capacitance between the electrodes 36,38 can be effectively measured and/or monitored for detecting the presence of blood in the absorbent pad. The electrodes are typically attached to a substrate 40 of a suitably known material.

[0044] It should be appreciated that in the capacitive sensors the output voltage of the sensor will be compared against a preset voltage to determine whether the absorbent pad is wet or dry. The rate of change of the output voltage may also be used to discriminate a blood loss event from noise, such as drift in the sensor output or wetness due to patient's sweat.

[0045] It should be appreciated that the sensor holder 12 can be secured to the patient 14 in a variety of suitable and known ways to ensure that the sensor 10 is properly secured and positioned over the insertion region 18 of the needle. In an embodiment, the sensor holder 12 can be secured to the patient 14 by a fastener, for example, having one or more straps as shown in Figure 1. For example, a strap 42,44 can be used to fasten a separate end 45,46 of the pad of the sensor holder 12. The straps 42,44 can include any variety of different materials, such as elastic, rigid or the like depending on the application. The straps 42,44 can be fastened to the sensor holder 12 by any known fastening mechanisms, such as a hoop and loop fastener, a buckle fastener, a Velcro fastener or other like fasteners.

[0046] In an embodiment, the apparatus can also include a force transducer 47, such as a pressure or motion sensitive transducer, to measure and monitor the force upon which the sensor holder is secured to the patient 14. The force transducer 47 can be utilized to ensure that the applied force is suitable for the particular application. In addition, the force transducer 47 may be adapted to enable one to monitor, control and adjust the applied force as deemed appropriate.

[0047] As previously discussed, the apparatus can be configured in a variety of different and suitable known ways to properly secure the sensor to the patient and to securely hold the needle in place to prevent dislodgement. In an embodiment, the apparatus can include a sensor holder 48 and a sensor 50 that is contained or located within the sensor holder 48 as shown in Figures 3A to 3C. In general, the sensor holder 48 is made of a suitable type of material, preferably a material that is impermeable to fluids, such as a plastic-based material. In this way, blood due to blood loss from the patient upon dislodgement of the needle does not contact the sensor.

Even so, the sensor 50 is still capable of detecting the presence of blood. In this regard, the sensor 50 can be used repeatedly without having to clean it after each use, or at least minimizing the amount of cleaning that is required.

[0048] In an embodiment, the sensor holder 48 includes a base 52 with a cavity 54 for holding the sensor 50 inside of the sensor holder 48 as shown in Figures 3A to 3C. The sensor holder 48 further includes a lid or top 56 to cover the sensor 50 once inside of the cavity 54. Preferably, the sensor is inserted into the cavity and the cavity is over-molded in a known and suitable way. Alternatively, the lid 56 can be removably attached.

[0049] The sensor holder 48 is preferably made from a molded flexible plastic or polymeric material for protecting and securing the sensor, needle and other components of the apparatus of the present invention as previously discussed. It also has a preferable angular shape such that the sensor holder 48 effectively covers the vascular access region of the needle which can be located on any suitable part of the patient's body, such as the upper arm, lower arm, upper thigh area or the like. This also facilitates securing the sensor holder to the patient and can further enhance the comfort level of the patient during use.

[0050] It should be appreciated that the sensor holder can be made from a variety of different and suitable materials and configured in a variety of different ways. For example, the thickness of the sensor holder is such that it does not compromise the integrity of the sensor holder to protect the needle and properly hold the sensor while at the same time it does not compromise the extent to which the sensor is capable of detecting blood loss due to needle dislodgement with high sensitivity and selectivity. Further, the sensor holder can be made of a plastic or other like suitable polymeric material that is both flexible and essentially impermeable to liquid or fluid, such as blood. This allows the apparatus to be rinsed without having to clean the sensor. In this regard, the risk of infection due to re-use can be effectively eliminated or at the very least greatly minimized.

[0051] As shown in Figures 3A to 3C, the sensor holder 48 has a channeled area 60 under which the needle, respective blood lines and the like are positioned. In addition, the sensor holder 48 can include a pair of spacers 62 that extend along at least a portion of the bottom surface of the sensor holder 48. The channeled area 60 and spacer 62 can act as a guide to further position the needle, blood lines, absorbent pad and the like, such that the sensor 50 is properly aligned with respect to the needle and access region. This can facilitate the detection of blood due to blood loss upon dislodgement of the needle. In this regard, the sensor 50 can be securely positioned in close proximity to the needle without disrupting the way in which the needle is inserted into the patient.

[0052] The sensor 50 includes a capacitive sensor that preferably includes a single electrode formed in a sheet or plate configuration. The electrode is preferably made

of copper. As the capacitance of the absorbent pad increases due to the presence of blood, the single electrode capacitive sensor can detect the increased capacitance of blood as compared to air (i.e., no blood present) due to the coupling of field lines between the electrode and the ground of the sensor. The non-contact nature of this type of sensor is desirable because cleaning of the sensor after use can be effectively minimized or avoided as previously discussed.

[0053] Applicants have surprisingly found that the capacitive sensor can detect wetness due to the presence of blood in an absorbent pad overlying the needle, with a high degree of sensitivity and specificity to needle dislodgement without contacting the absorbent pad and for that matter blood. In this regard, the sensor is capable of detecting an increased capacitance of the blood-wetted absorbent pad which results from its large dielectric constant as compared to a dry absorbent pad. This can be done by measuring the charging and discharging times of the electrode or by measuring the change in the dielectric constant due to the presence of blood in other known and suitable ways.

[0054] It should be appreciated that an embodiment of the apparatus as shown in Figures 3A to 3C can be secured to the patient in a number of different and suitably known ways. In an embodiment, the sensor holder 48 includes a pair of fastener members 64 onto which straps or other like fasteners can be attached to fasten the apparatus to the patient. The straps and/or fasteners can include any suitably known straps and/or fasteners as discussed above.

[0055] As previously discussed, the apparatus of the present invention can be effectively utilized to detect needle dislodgement by detecting the presence of wetness due to blood loss upon dislodgement of the needle from the patient. The apparatus can be applied in a number of different applications, such as medical therapies or treatments, particularly hemodialysis. In hemodialysis, needles are inserted into a patient's arteries and veins to connect blood flow to and from the hemodialysis machine.

[0056] Under these circumstances, if the needle becomes dislodged, particularly the venous needle (i.e., a needle inserted into a vein), the amount of blood loss from the patient can be significant and immediate. In this regard, the needle dislodgement detection apparatus of the present invention can be utilized to controllably and effectively minimize blood loss from a patient due to dislodgement of the needle, such as during hemodialysis.

[0057] In an embodiment, the present invention provides an apparatus for controlling the blood loss from a patient due to venous needle dislodgement. The apparatus can include a needle dislodgement device as previously discussed.

[0058] In an embodiment, the apparatus includes a controller (not shown) that is in electrical contact with the sensor. The controller can be configured in a variety of different ways depending on the application thereof. Up-

on detection of the presence of blood due to needle dislodgement, the sensor produces a signal indicative of the degree of wetness due to blood. This signal can then be transmitted to the controller which is electrically connected to the sensor.

[0059] The controller can process the signal in a variety of different ways such that the blood loss from the patient is minimized. In an embodiment, the controller is in communication with a hemodialysis machine (not shown). This communication can be either hard wired (i.e., electrical communication cable), a wireless communication (i.e., wireless RF interface), a pneumatic interface or the like. In this regard, the controller can process the signal to communicate with the hemodialysis machine to shut off or stop the blood pump associated with the hemodialysis machine and thus effectively minimize the amount of blood loss from the patient due to needle dislodgement during hemodialysis.

[0060] The controller can communicate with the hemodialysis machine in a variety of other ways. For example, the controller and hemodialysis machine can communicate to activate a venous line clamp (not shown) for preventing further blood flow via the venous needle thus minimizing blood loss to the patient. In an embodiment, the venous line clamp is activated by the controller and attached to or positioned in proximity to the sensor and sensor holder such that it can clamp off the venous line in close proximity to the needle. Once clamped, the hemodialysis machine is capable of sensing an increase in pressure and can be programmed to shut-off the blood pump upon sensing pressure within the blood flow line which is above a predetermined level. In this regard, the sensor, sensor holder and venous line clamp can act together as a stand-alone control unit. Alternatively, the venous line clamp can be controllably attached to the hemodialysis machine.

[0061] It should be appreciated that the sensor output signal can be combined with other less sensitive blood loss detection methods, such as venous pressure measurements, systemic blood pressure, the like or combinations thereof, to improve specificity to needle dislodgement.

[0062] Applicants have found that the apparatus of the present invention can detect blood loss due to needle dislodgement with high sensitivity and selectivity such that responsive measures can be taken to minimize blood loss due to needle dislodgement. The ability to act responsively and quickly to minimize blood loss upon detection thereof is particularly important with respect to needle dislodgement during hemodialysis. If not detected and responded to immediately, the amount of blood loss can be significant. In an embodiment, the present invention is capable of taking active or responsive measures, to minimize blood loss (i.e., shut-off blood pump, activate venous line clamp or the like) within about three seconds or less, preferably within about two to about three seconds upon detection of needle dislodgement.

[0063] In addition, the controller can be utilized to mon-

itor and/or control one or more treatment parameters during hemodialysis. These parameters can include, for example, the detection of blood due to blood loss upon needle dislodgement, the change in blood flow, the detection of air bubbles in the arterial line, detection of movement of the sensor during treatment, detection and/or monitoring of electrical continuity of the sensor or other like treatment parameters. In an embodiment, the controller includes a display (not shown) for monitoring one or more of the parameters.

Claims

1. An apparatus for detecting dislodgement of a needle (16) inserted into a patient (14) comprising a sensor (10, 50) capable of detecting wetness due to blood upon dislodgement of the needle, a sterile absorbent pad (20) capable of absorbing blood lost from the patient due to the dislodgement of the needle; and a sensor holder (12, 48) adapted to secure the sensor and the absorbent pad adjacent to the needle such that the absorbent pad is disposed between the sensor and the needle, **characterised in that** the sensor is located inside of the sensor holder such that the sensor does not contact blood and the absorbent pad for detecting wetness therein, and **in that** the sensor comprises a capacitive sensor.
2. The apparatus of Claim 1, wherein the capacitive sensor (34) includes one or more electrodes (36, 38).
3. The apparatus of Claim 1 to 2, wherein the sensor (10, 50) produces a signal upon detection of blood loss.
4. The apparatus of Claim 3 further comprising a control device adapted to receive the signal for monitoring and controlling blood loss due to the dislodgement of the needle (16) during haemodialysis.
5. The apparatus of any one of Claims 1 to 4, wherein the sensor holder (12, 48) comprises a flexible material that can conform to a vascular access region such that the sensor (10, 50) is capable of detecting blood loss due to needle dislodgement.
6. The apparatus of Claim 4, wherein the control device is communicatively coupled to a haemodialysis machine via an electrical communication cable or a cordless interface to minimize blood loss due to needle dislodgement.
7. The apparatus of Claim 6, wherein the control device is adapted to monitor one or more haemodialysis treatment parameters including wetness due to

blood loss, change in blood flow and detection of arterial air bubbles during haemodialysis.

8. The apparatus of Claim 4, wherein the control device comprises a display for monitoring each of the parameters.

9. The apparatus of Claim 1, wherein the sensor holder (12, 48) defines an interior for receiving the absorbent pad (20) and at least a portion of the needle (16) such that the sensor (10, 50) is capable of detecting blood loss due to dislodgement of the needle.

10. A method of detecting needle (16) dislodgement comprising the steps of:

providing an apparatus according to Claim 1;
and
securing the sensor and absorbent pad to the patient using the sensor holder so that the absorbent pad lies between the sensor and the needle.

Patentansprüche

1. Vorrichtung zum Detektieren einer Verlagerung einer Nadel (16), die in einen Patienten (14) eingesetzt ist, umfassend einen Sensor (10, 50), der fähig ist, Feuchtigkeit aufgrund von Blut nach bzw. bei einer Verlagerung der Nadel zu detektieren, ein steriles absorbierendes bzw. Absorbenskissen (20), das fähig ist, Blut zu absorbieren, das von dem Patient aufgrund der Verlagerung der Nadel verloren wurde; und einen Sensorhalter (12, 48), der adaptiert ist, um den Sensor und das Absorbenskissen benachbart zu der Nadel derart zu sichern, dass das Absorbenskissen zwischen dem Sensor und der Nadel angeordnet ist, **dadurch gekennzeichnet, dass** der Sensor im Inneren des Sensorhalters derart angeordnet ist, dass der Sensor nicht Blut und das Absorbenskissen zum Detektieren von Feuchtigkeit darin kontaktiert, und dass der Sensor einen kapazitiven Sensor umfasst.

2. Vorrichtung nach Anspruch 1, wobei der kapazitive Sensor (34) eine oder mehrere Elektrode(n) (36, 38) enthält.

3. Vorrichtung nach Anspruch 1 oder 2, wobei der Sensor (10, 50) ein Signal nach bzw. bei einer Detektion eines Blutverlusts produziert.

4. Vorrichtung nach Anspruch 3, weiters umfassend eine Steuer- bzw. Regelvorrichtung, die adaptiert ist, um das Signal zum Überwachen und zum Steuern bzw. Regeln eines Blutverlustes aufgrund der Ver-

lagerung der Nadel (16) während einer Hämodialyse zu empfangen.

5. Vorrichtung nach einem der Ansprüche 1 bis 4, wobei der Sensorhalter (12, 48) ein flexibles Material umfasst, welches mit einem vaskulären Zutritts- bzw. Zugriffsbereich derart übereinstimmen kann, dass der Sensor (10, 50) fähig ist, einen Blutverlust aufgrund einer Nadelverlagerung zu detektieren.

6. Vorrichtung nach Anspruch 4, wobei die Steuer- bzw. Regelvorrichtung kommunikativ mit einer Hämodialysemaschine über ein elektrisches Verbindungs- bzw. Kommunikationskabel oder eine kabellose Schnittstelle gekoppelt ist, um einen Blutverlust aufgrund einer Nadelverlagerung zu minimieren.

7. Vorrichtung nach Anspruch 6, wobei die Steuer- bzw. Regelvorrichtung adaptiert ist, um einen oder mehrere Hämodialyse-Behandlungsparameter zu überwachen, beinhaltend Feuchtigkeit aufgrund von Blutverlust, Veränderung in einem Blutfluss bzw. -strom und Detektion von arteriellen Luftblasen während einer Hämodialyse.

8. Vorrichtung nach Anspruch 4, wobei die Steuer- bzw. Regelvorrichtung eine Anzeige zum Überwachen von jedem der Parameter umfasst.

9. Vorrichtung nach Anspruch 1, wobei der Sensorhalter (12, 48) ein Inneres zum Aufnehmen des Absorbenskissens (20) und wenigstens eines Abschnitts der Nadel (16) derart definiert, dass der Sensor (10, 50) fähig ist, einen Blutverlust aufgrund einer Verlagerung der Nadel zu detektieren.

10. Verfahren zum Detektieren einer Verlagerung einer Nadel (16), umfassend die Schritte:

Bereitstellen einer Vorrichtung nach Anspruch 1; und
Sichern des Sensors und des Absorbenskissens an dem Patienten unter Verwendung des Sensorhalters derart, dass das Absorbenskissen zwischen dem Sensor und der Nadel liegt.

Revendications

1. Dispositif de détection du déboîtement d'une aiguille (16) insérée dans un patient (14) comprenant un capteur (10, 50) permettant de détecter l'humidité due à la présence de sang lors du déboîtement de l'aiguille,
une compresse absorbante stérile (20) permettant d'absorber le sang perdu par le patient du fait du déboîtement de l'aiguille ; et
un support de capteur (12, 48) adapté afin de main-

- tenir le capteur et la compresse absorbante de manière adjacente à l'aiguille, de telle sorte que la compresse absorbante est disposée entre le capteur et l'aiguille, **caractérisé en ce que** le capteur est situé à l'intérieur du support de capteur, de telle sorte que le capteur n'entre pas en contact avec le sang et la compresse absorbante afin de détecter l'humidité à l'intérieur, et **en ce que** le capteur comprend un capteur capacitif.
2. Dispositif selon la revendication 1, dans lequel le capteur capacitif (34) comporte une ou plusieurs électrodes (36, 38).
3. Dispositif selon la revendication 1 ou 2, dans lequel le capteur (10, 50) produit un signal lors de la détection de perte de sang.
4. Dispositif selon la revendication 3, comprenant en outre un dispositif de commande adapté afin de recevoir le signal permettant de surveiller et de contrôler une perte de sang due au déboîtement de l'aiguille (16) au cours d'une hémodialyse.
5. Dispositif selon l'une quelconque des revendications 1 à 4, dans lequel le support de capteur (12, 48) comprend un matériau flexible qui peut se conformer à une zone d'accès vasculaire de telle sorte que le capteur (10, 50) est capable de détecter la perte de sang du fait du déboîtement de l'aiguille.
6. Dispositif selon la revendication 4, dans lequel le dispositif de commande est couplé de manière à pouvoir communiquer à une machine d'hémodialyse par l'intermédiaire d'un câble électrique de communication ou d'une interface sans fil de manière à minimiser la perte de sang du fait du déboîtement de l'aiguille.
7. Dispositif selon la revendication 6, dans lequel le dispositif de commande est adapté afin de surveiller un ou plusieurs paramètres de traitement d'hémodialyse comprenant l'humidité due à la perte de sang, une variation sur le débit de sang et la détection des bulles d'air artériel au cours de l'hémodialyse.
8. Dispositif selon la revendication 4, dans lequel le dispositif de commande comprend un dispositif d'affichage de manière à surveiller chacun des paramètres.
9. Dispositif selon la revendication 1, dans lequel le support de capteur (12, 48) définit une partie interne destinée à recevoir la compresse absorbante (20) et au moins une partie de l'aiguille (16) de telle sorte que le capteur (10, 50) est capable de détecter une perte de sang du fait du déboîtement de l'aiguille.
10. Procédé de détection de déboîtement d'une aiguille (16) comprenant les étapes de :
- préparation d'un dispositif selon la revendication 1,
fixation du capteur et de la compresse absorbante sur le patient en utilisant le support de capteur de telle sorte que la compresse absorbante se trouve placée entre le capteur et l'aiguille.

FIG.1

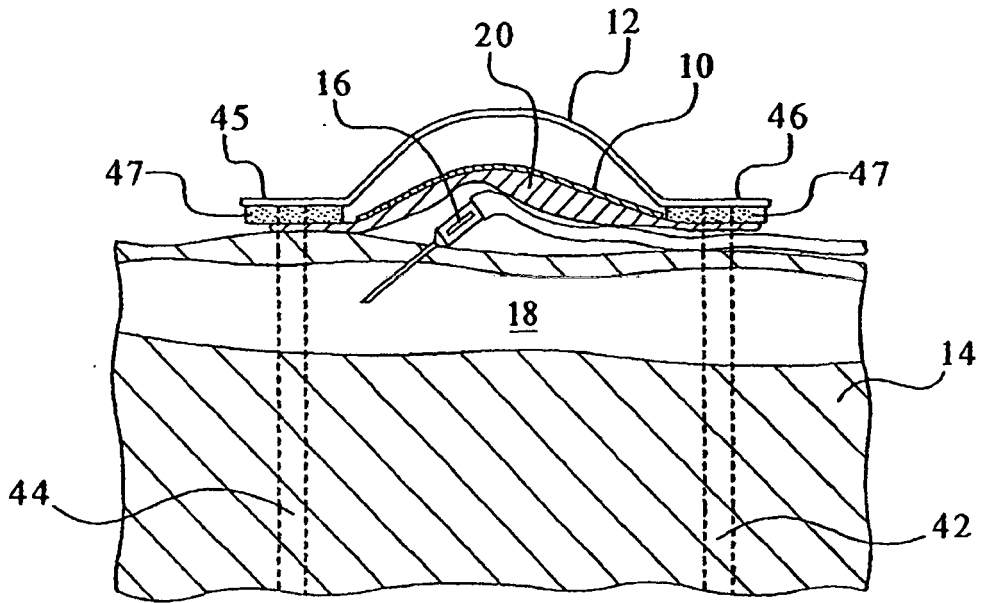

FIG.2A

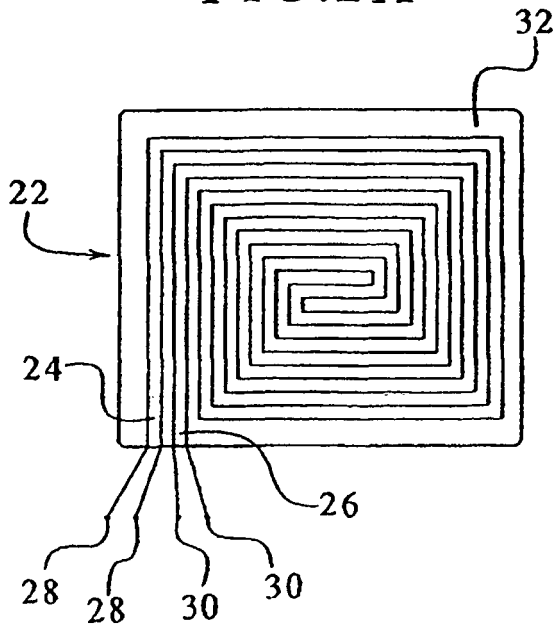

FIG.2B

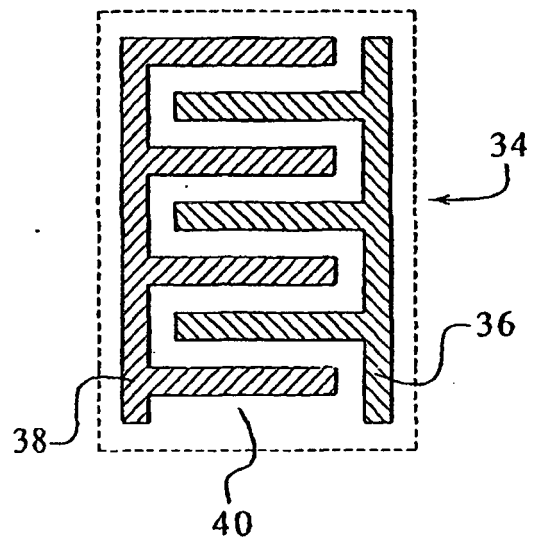

FIG.3A

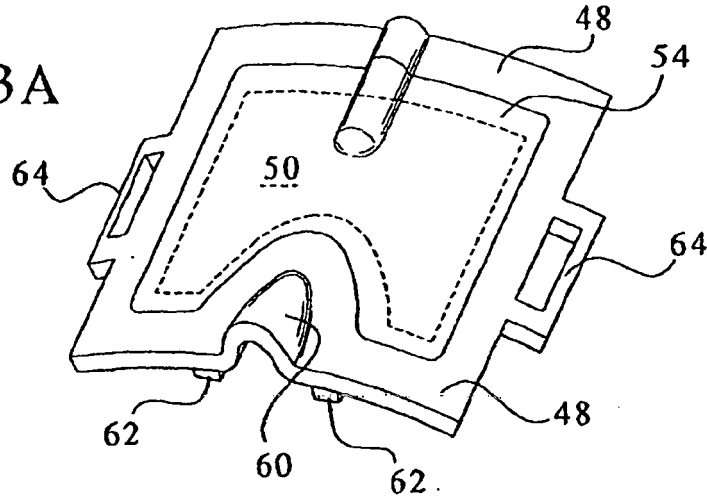

FIG.3B

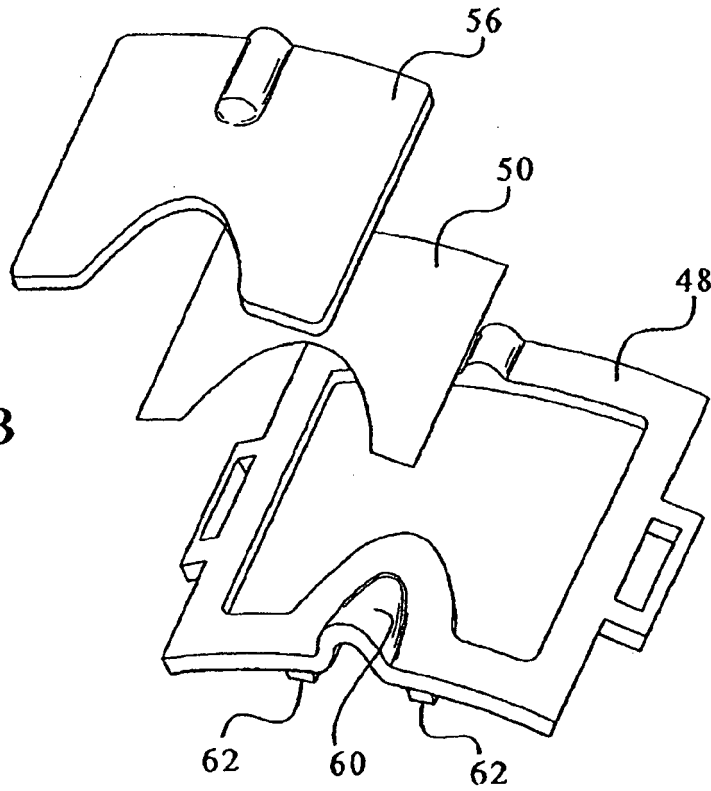
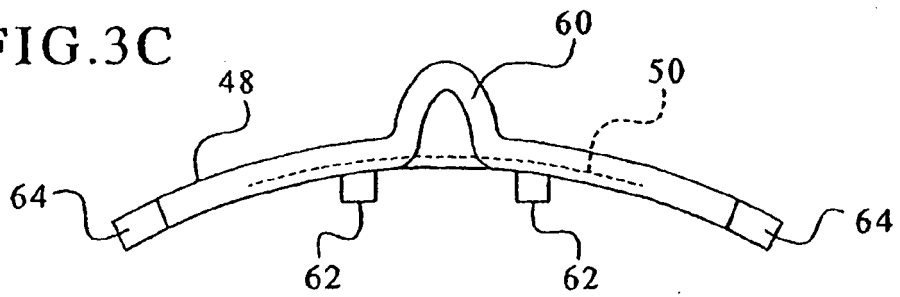

FIG.3C



专利名称(译)	针头移位检测		
公开(公告)号	EP1401518B2	公开(公告)日	2014-08-13
申请号	EP2002737267	申请日	2002-05-30
[标]申请(专利权)人(译)	巴克斯特国际公司		
申请(专利权)人(译)	百特国际有限公司.		
当前申请(专利权)人(译)	百特国际有限公司.		
[标]发明人	WARIAR RAMESH HARTRANFT THOMAS P CAMERON NORM LASSO ANGEL CARO HECTOR		
发明人	WARIAR, RAMESH HARTRANFT, THOMAS, P. CAMERON, NORM LASSO, ANGEL CARO, HECTOR		
IPC分类号	A61M5/168 A61M1/36 A61B5/00 A61M5/00 A61B5/15 A61M5/158 G01N27/12 G01N27/22		
CPC分类号	A61M5/158 A61B5/15003 A61B5/150503 A61B5/15087 A61B5/150961 A61B5/153 A61M1/3656 A61M5/16831 A61M2005/1588 A61M2205/13 A61M2205/18 G01N27/121 G01N27/223		
代理机构(译)	POTTER CLARKSON LLP		
优先权	09/888154 2001-06-22 US		
其他公开文献	EP1401518B1 EP1401518A1		
外部链接	Espacenet		

摘要(译)

提供了一种用于检测插入患者体内的针的移位的装置，包括：传感器，其能够检测由于血液引起的湿度；以及传感器保持器，其适于将传感器固定到患者，使得传感器检测由于患者的失血导致的湿度。针的移位。还提供了用于检测，监测和/或控制由于针头移位导致的患者失血的方法和装置。

