

(19)



(11)

EP 3 328 481 B1

(12)

EUROPEAN PATENT SPECIFICATION

(45) Date of publication and mention of the grant of the patent:
15.05.2019 Bulletin 2019/20

(51) Int Cl.:
A61N 1/05 (2006.01) A61B 5/00 (2006.01)
A61N 1/36 (2006.01) G16H 40/63 (2018.01)
G06F 19/00 (2018.01)

(21) Application number: **16732137.1**

(86) International application number:
PCT/US2016/037226

(22) Date of filing: **13.06.2016**

(87) International publication number:
WO 2017/019191 (02.02.2017 Gazette 2017/05)

(54) USER INTERFACE FOR CUSTOM PATTERNED ELECTRICAL STIMULATION

BENUTZERSCHNITTSTELLE FÜR ELEKTRISCHE STIMULATION MIT PERSONALISIERTEM MUSTER

INTERFACE UTILISATEUR DE STIMULATION ÉLECTRIQUE À MOTIFS PERSONNALISÉS

(84) Designated Contracting States:
AL AT BE BG CH CY CZ DE DK EE ES FI FR GB GR HR HU IE IS IT LI LT LU LV MC MK MT NL NO PL PT RO RS SE SI SK SM TR

(72) Inventor: **WECHTER, David Ernest**
San Francisco, California 94109 (US)

(30) Priority: **30.07.2015 US 201562198957 P**

(74) Representative: **Vossius & Partner**
Patentanwälte Rechtsanwälte mbB
Siebertstrasse 3
81675 München (DE)

(43) Date of publication of application:
06.06.2018 Bulletin 2018/23

(56) References cited:
US-A1- 2008 163 097 US-A1- 2013 053 926
US-A1- 2014 172 045 US-A1- 2015 165 209

(73) Proprietor: **Boston Scientific Neuromodulation Corporation**
Valencia, CA 91355 (US)

EP 3 328 481 B1

Note: Within nine months of the publication of the mention of the grant of the European patent in the European Patent Bulletin, any person may give notice to the European Patent Office of opposition to that patent, in accordance with the Implementing Regulations. Notice of opposition shall not be deemed to have been filed until the opposition fee has been paid. (Art. 99(1) European Patent Convention).

Description

TECHNICAL FIELD

[0001] This document relates generally to medical devices and more particularly to an apparatus using a user interface that allows a user to customize various patterns of electrical stimulation pulses.

BACKGROUND

[0002] Neurostimulation, also referred to as neuromodulation, has been proposed as a therapy for a number of conditions. Examples of neurostimulation include Spinal Cord Stimulation (SCS), Deep Brain Stimulation (DBS), Peripheral Nerve Stimulation (PNS), and Functional Electrical Stimulation (FES). Implantable neurostimulation systems have been applied to deliver such a therapy. An implantable neurostimulation system may include an implantable neurostimulator, also referred to as an implantable pulse generator (IPG), and one or more implantable leads each including one or more electrodes. The implantable neurostimulator delivers neurostimulation energy through one or more electrodes placed on or near a target site in the nervous system. An external programming device is used to program the implantable neurostimulator with stimulation parameters controlling the delivery of the neurostimulation energy.

[0003] In one example, the neurostimulation energy is delivered in the form of electrical neurostimulation pulses. The delivery is controlled using stimulation parameters that specify spatial (where to stimulate), temporal (when to stimulate), and informational (patterns of pulses directing the nervous system to respond as desired) aspects of a pattern of neurostimulation pulses. Many current neurostimulation systems are programmed to deliver periodic pulses with one or a few uniform waveforms continuously or in bursts. However, the human nervous systems use neural signals having much more sophisticated patterns to communicate various types of information, including sensations of pain, pressure, temperature, etc. The nervous system may interpret an artificial stimulation with a simple pattern of stimuli as an unnatural phenomenon, and respond with an unintended and undesirable sensation and/or movement. For example, some neurostimulation therapies are known to cause paresthesia and/or vibration of non-targeted tissue or organ.

[0004] Recent research has shown that the efficacy and efficiency of certain neurostimulation therapies can be improved, and their side-effects can be reduced, by using patterns of neurostimulation pulses that emulate natural patterns of neural signals observed in the human body. While modern electronics can accommodate the need for generating such sophisticated pulse patterns, the capability of a neurostimulation system depends on its post-manufacturing programmability to a great extent. For example, a sophisticated pulse pattern may only ben-

efit a patient when it is customized for that patient, and stimulation patterns predetermined at the time of manufacturing may substantially limit the potential for the customization. Such customization may be performed at least in part by a user such as a physician or other caregiver with the patient in a clinical setting. US2013053926 discloses a system for delivering vagus nerve stimulation for neural stimulation therapies which has a muscular response detection circuit using signals sensed by a sensing circuit to detect muscle activity.

SUMMARY

[0005]

An example (e.g., "Example 1") of a neurostimulation system includes a programming control circuit and a user interface. The programming control circuit may be configured to generate a plurality of stimulation parameters controlling delivery of neurostimulation pulses according to one or more neurostimulation programs each specifying a pattern of the neurostimulation pulses. The user interface is coupled to the programming control circuit and includes a display screen, a user input device, and a neurostimulation program circuit coupled to the display screen and the user input device. The neurostimulation program circuit may include a program creation module configured to create building blocks for the one or more neurostimulation programs and a program scheduling module configured to schedule delivery of the one or more neurostimulation programs. The program creation module may include a pulse train (PT) construction module and a train grouping (TG) construction module. The PT construction module may be configured to allow for construction of one or more PTs using the display screen and the user input device. The one or more PTs each include one or more pulse blocks (PBs) each including a plurality of pulses of the neurostimulation pulses. The TG construction module may be configured to allow for construction of one or more TGs using the display screen and the user input device. The one or more TGs each include one or more PTs.

In Example 2, the subject matter of Example 1 may optionally be configured such that the display screen includes a touchscreen, and a portion of the user input device is integrated into the touchscreen.

In Example 3, the subject matter of any one or any combination of Examples 1 and 2 may optionally be configured such that the neurostimulation program circuit is configured to display a neurostimulation program area on the screen in response to a neurostimulation programming command and to receive user commands using the user input device. The user commands include a program creation command and a program scheduling command.

In Example 4, the subject matter of Example 3 may

optionally be configured such that the neurostimulation program circuit is configured to display a program creation tab and a program scheduling tab on the screen, to receive the program creation command when the program creation tab is selected, and to receive the program scheduling command when the program scheduling tab is selected.

In Example 5, the subject matter of any one or any combination of Examples 3 and 4 may optionally be configured such that the program creation module is configured to display a PT construction area and a TG construction area on the screen in response to the program creation command.

In Example 6, the subject matter of Example 5 may optionally be configured such that the PT construction module is configured to display a PT of the one or more PTs on the PT construction area and allow definition of the plurality of pulses in each PB of the one or more PBs of the PT.

In Example 7, the subject matter of Example 6 may optionally be configured such that the TG construction module is configured to display a TG of the one or more TGs on the TG construction area and allow definition of the TG as a sequence of PTs each selected from the one or more PTs.

In Example 8, the subject matter of Example 7 may optionally be configured such that the TG construction module is configured to allow specification of a number of repetitions for the one or more PBs of each PT of the sequence of PTs.

In Example 9, the subject matter of any one or any combination of Examples 7 and 8 may optionally be configured such that the TG construction module is configured to allow specification of an order of the one or more PBs of each PT of the sequence of PTs.

In Example 10, the subject matter of any one or any combination of Examples 3 to 9 may optionally be configured such that the program scheduling module is configured to display a program scheduling area on the screen in response to the program scheduling command and to allow scheduling of each program of the one or more neurostimulation programs including time of delivery for each TG of the one or more TGs in the each program.

In Example 11, the subject matter of Example 10 may optionally be configured such that the program scheduling module is configured to allow specification of a frequency of delivery of the each program.

In Example 12, the subject matter of any one or any combination of Examples 10 and 11 may optionally be configured such that the program scheduling module is configured to allow scheduling on a plurality of programs of the one or more neurostimulation programs to be delivered simultaneously.

In Example 13, the subject matter of any one or any combination of Examples 1 to 12 may optionally be configured to further include a storage device including a PT library having one or more stored PTs, and

the PT construction module is configured to allow use of the one or more stored PTs in the construction of the one or more PTs and to allow each newly constructed PT of the one or more PTs to be added to the one or more stored PTs in the PT library.

In Example 14, the subject matter of Example 13 may optionally be configured such that the storage device further comprises a TG library having one or more stored TGs, and the TG construction module is configured to allow use of the one or more stored TGs in the construction of the one or more TGs and to allow each newly constructed TG of the one or more TGs to be added to the one or more stored TGs in the TG library.

In Example 15, the subject matter of any one or any combination of Examples 13 and 14 may optionally be configured such that the storage device further comprises a program library having one or more scheduled programs, and the program scheduling module is configured to allow to schedule a new program by rescheduling a scheduled program of the one or more scheduled programs and to allow each newly scheduled program to be added to the one or more scheduled programs in the program library.

An example of a method (e.g., Example 16") for delivering neurostimulation pulses is also provided. The method includes displaying a neurostimulation program area on a user interface and generating a plurality of stimulation parameters controlling delivery of the neurostimulation pulses based on one or more neurostimulation programs each specifying a pattern of the neurostimulation pulses. The neurostimulation program area allows a user to create building blocks for the one or more neurostimulation programs and to schedule delivery of the one or more neurostimulation programs. The one or more building blocks include one or more pulse blocks (PBs) each including a plurality of pulses of the neurostimulation pulses, one or more pulse trains (PTs) each including one or more PBs, and one or more train groupings (TGs) each including one or more PTs.

In Example 17, the subject matter of Example 16 may optionally further include delivering the neurostimulation pulses using an implantable medical device.

In Example 18, the subject matter of Example 16 may optionally include receiving user commands from the user using the user interface, the user commands including a program creation command and a program scheduling command.

In Example 19, the subject matter of Example 18 may optionally include displaying a program creation tab and a program scheduling tab on the screen, receiving the program creation command when the program creation tab is selected, and receiving the program scheduling command when the program scheduling tab being selected.

In Example 20, the subject matter of Example 19

may optionally include displaying a PT construction area and a TG construction area on the screen in response to the program creation command, receiving from the user a selection of a PT from the one or more PTs, displaying the selected PT in the PT construction area, allowing the user to define the plurality of pulses in each PB of the one or more PBs of the selected PT, receiving from the user a selection of a TG from the one or more TGs, displaying the selected TG in the TG construction area, and allowing the user to define the TG as a sequence of PTs each selected from the one or more PTs.

In Example 21, the subject matter of Example 20 may optionally include receiving from the user a number of repetitions for the one or more PBs of each PT of the sequence of PTs.

In Example 22, the subject matter of Example 21 may optionally include receiving from the user an order of the one or more PBs of each PT of the sequence of PTs.

In Example 23, the subject matter of Example 19 may optionally include displaying a program scheduling area on the screen in response to the programming scheduling command, receiving from the user a selection of a program from the one or more neurostimulation programs, displaying the selected program in the program scheduling area, and allowing the user to schedule the selected program, including specifying time of delivery for each TG of the one or more TGs in the each program.

In Example 24, the subject matter of Example 23 may optionally include allowing the user to specify a frequency of delivery of the each program.

In Example 25, the subject matter of Example 23 may optionally include receiving from the user he user to schedule a plurality of neurostimulation programs of the one or more neurostimulation programs to be run simultaneously.

[0006] This Summary is an overview of some of the teachings of the present application and not intended to be an exclusive or exhaustive treatment of the present subject matter. Further details about the present subject matter are found in the detailed description and appended claims. Other aspects of the disclosure will be apparent to persons skilled in the art upon reading and understanding the following detailed description and viewing the drawings that form a part thereof, each of which are not to be taken in a limiting sense. The scope of the present disclosure is defined by the appended claims and their legal equivalents.

BRIEF DESCRIPTION OF THE DRAWINGS

[0007] The drawings illustrate generally, by way of example, various embodiments discussed in the present document. The drawings are for illustrative purposes only and may not be to scale.

FIG. 1 illustrates an embodiment of a neurostimulation system.

FIG. 2 illustrates an embodiment of a stimulation device and a lead system, such as may be implemented in the neurostimulation system of FIG. 1.

FIG. 3 illustrates an embodiment of a programming device, such as may be implemented in the neurostimulation system of FIG. 1.

FIG. 4 illustrates an implantable neurostimulation system and portions of an environment in which the system may be used.

FIG. 5 illustrates an embodiment of an implantable stimulator and one or more leads of an implantable neurostimulation system, such as the implantable system of FIG. 4.

FIG. 6 illustrates an embodiment of an external programming device of an implantable neurostimulation system, such as the external system of FIG. 4.

FIG. 7 is an illustration of an embodiment of a program creation area on a display screen of a graphical user interface (GUI).

FIG. 8 is an illustration of an embodiment of a program scheduling area on a display screen of the GUI.

FIG. 9 illustrates an embodiment of a neurostimulation program circuit of an external programming device, such as the external programming device of FIG. 6.

FIG. 10 illustrates an embodiment of a method for creating and scheduling neurostimulation programs.

DETAILED DESCRIPTION

[0008] In the following detailed description, reference is made to the accompanying drawings which form a part hereof, and in which is shown by way of illustration specific embodiments in which the invention may be practiced. These embodiments are described in sufficient detail to enable those skilled in the art to practice the invention, and it is to be understood that the embodiments may be combined, or that other embodiments may be utilized and that structural, logical and electrical changes may be made without departing from the spirit and scope of the present invention. References to "an", "one", or "various" embodiments in this disclosure are not necessarily to the same embodiment, and such references contemplate more than one embodiment. The following detailed description provides examples, and the scope of the present invention is defined by the appended claims and their legal equivalents.

[0009] This document discusses a method and system for programming neurostimulation pulse patterns using a user interface, such as a graphical user interface (GUI). Advancements in neuroscience and neurostimulation research have led to a demand for using complex and/or individually optimized patterns of neurostimulation pulses for various types of therapies. The capability of a neurostimulation system in treating various types of disorders will be limited by the programmability of such pat-

terns of neurostimulation pulses. In various embodiments, the present system allows for custom definition of a pattern of neurostimulation pulses, which includes custom definition of waveforms being the building blocks of the pattern. Such custom definition is achieved by using a user interface that makes it possible for the user to perform the custom definition of potentially very complex patterns of neurostimulation pulses by creating and editing graphical representations of relatively simple individual building blocks for each of the patterns. In various embodiments, the individually definable waveforms may include pulses, pulse blocks each including a burst of pulses, pulse trains each including a sequence of pulse blocks, train groups each including a sequence of pulse trains, and neurostimulation programs (also referred to as "programs" in this document) each including one or more train groups scheduled for delivery. In various embodiments, the present system provides for patterns of neurostimulation pulses not limited to waveforms predefined at the time of manufacturing, thereby accommodating need for customization of neurostimulation pulse patterns as well as need for new types of neurostimulation pulse patterns that may, for example, result from future research in neurostimulation. This may also facilitate design of a general-purpose neurostimulation device that can be configured by a user for delivering specific types of neurostimulation therapies by programming the device using the user interface.

[0010] In various embodiments, the present subject matter may be implemented using is a combination of hardware and software designed to provide users such as physicians of other caregivers with ability to create custom waveforms and patterns in an effort to increase therapeutic efficacy and/or patient satisfaction for neurostimulation therapies, including but not being limited to SCS and DBS therapies. While neurostimulation is specifically discussed as an example, the present subject matter may apply to any therapy that employs stimulation pulses of electrical or other form of energy.

[0011] FIG. 1 illustrates an embodiment of a neurostimulation system 100. System 100 includes electrodes 106, a stimulation device 104, and a programming device 102. Electrodes 106 are configured to be placed on or near one or more neural targets in a patient. Stimulation device 104 is configured to be electrically connected to electrodes 106 and deliver neurostimulation energy, such as in the form of electrical pulses, to the one or more neural targets through electrodes 106. The delivery of the neurostimulation is controlled by using a plurality of stimulation parameters, such as stimulation parameters specifying a pattern of the electrical pulses and a selection of electrodes through which each of the electrical pulses is delivered. In various embodiments, at least some parameters of the plurality of stimulation parameters are programmable by a user, such as a physician or other caregiver who treats the patient using system 100. Programming device 102 provides the user with accessibility to the user-programmable parameters. In various

embodiments, programming device 102 is configured to be communicatively coupled to stimulation device via a wired or wireless link.

[0012] In various embodiments, programming device 102 includes a user interface that allows the user to set and/or adjust values of the user-programmable parameters by creating and/or editing graphical representations of various waveforms. Such waveforms may include, for example, the waveform of a pattern of neurostimulation pulses to be delivered to the patient as well as individual waveforms that are used as building blocks of the pattern of neurostimulation pulses. Examples of such individual waveforms include pulses, pulse groups, and groups of pulse groups, as further discussed below. The user may also be allowed to define an electrode selection specific to each individually defined waveform. In the illustrated embodiment, the user interface includes a GUI 110. While a GUI is specifically discussed as an example of the user interface of the present system, any type of user interface accommodating various functions of the GUI as discussed in this document can be used as the user interface of the present system.

[0013] FIG. 2 illustrates an embodiment of a stimulation device 204 and a lead system 208, such as may be implemented in neurostimulation system 100. Stimulation device 204 represents an embodiment of stimulation device 104 and includes a stimulation output circuit 212 and a stimulation control circuit 214. Stimulation output circuit 212 produces and delivers neurostimulation pulses. Stimulation control circuit 214 controls the delivery of the neurostimulation pulses using the plurality of stimulation parameters, which specifies a pattern of the neurostimulation pulses. Lead system 208 includes one or more leads each configured to be electrically connected to stimulation device 204 and a plurality of electrodes 206 distributed in the one or more leads. The plurality of electrodes 206 includes electrode 206-1, electrode 206-2, ... electrode 206-N, each a single electrically conductive contact providing for an electrical interface between stimulation output circuit 212 and tissue of the patient, where $N \geq 2$. The neurostimulation pulses are each delivered from stimulation output circuit 212 through a set of electrodes selected from electrodes 206. In various embodiments, the neurostimulation pulses may include one or more individually defined pulses, and the set of electrodes may be individually definable by the user for each of the individually defined pulses.

[0014] In various embodiments, the number of leads and the number of electrodes on each lead depend on, for example, the distribution of target(s) of the neurostimulation and the need for controlling the distribution of electric field at each target. In one embodiment, lead system 208 includes 2 leads each having 8 electrodes.

[0015] FIG. 3 illustrates an embodiment of a programming device 302, such as may be implemented in neurostimulation system 100. Programming device 302 represents an embodiment of programming device 102 and includes a storage device 318, a programming control

circuit 316, and a GUI 310. Storage device 318 stores a plurality of individually definable waveforms. Programming control circuit 316 generates the plurality of stimulation parameters that controls the delivery of the neurostimulation pulses according to the pattern of the neurostimulation pulses. GUI 310 represents an embodiment of GUI 110 and allows the user to define the pattern of the neurostimulation pulses using one or more waveforms selected from the plurality of individually definable waveforms.

[0016] In various embodiments, GUI 310 includes a neurostimulation program circuit 320 that creates neurostimulation programs and schedules delivery of the neurostimulation programs. In various embodiments, neurostimulation program circuit 320 allows the user to create each neurostimulation program using individually definable waveforms or building blocks such as pulses, pulse blocks each including a burst of pulses, pulse trains each including a sequence of pulse blocks, and train groupings each including a sequence of pulse trains. In various embodiments, neurostimulation program circuit 320 allows the user to schedule delivery of each neurostimulation program, such as by specifying delivery time for certain building blocks and a frequency at which the program is delivered. In various embodiments, neurostimulation program circuit 320 allows the user to create each building block or program using one or more waveforms stored in storage device 318 as templates. In various embodiments, neurostimulation program circuit 320 allows each newly created building block or program to be saved as additional waveforms stored in storage device 318.

[0017] In one embodiment, GUI 310 includes a touchscreen. In various embodiments, GUI 310 includes any type of presentation device, such as interactive or non-interactive screens, and any type of user input devices that allow the user to edit the waveforms or building blocks and schedule the programs, such as touchscreen, keyboard, keypad, touchpad, trackball, joystick, and mouse. In various embodiments, circuits of neurostimulation 100, including its various embodiments discussed in this document, may be implemented using a combination of hardware and software. For example, the circuit of GUI 100, stimulation control circuit 214, and programming control circuit 316, including their various embodiments discussed in this document, may be implemented using an application-specific circuit constructed to perform one or more particular functions or a general-purpose circuit programmed to perform such function(s). Such a general-purpose circuit includes, but is not limited to, a microprocessor or a portion thereof, a microcontroller or portions thereof, and a programmable logic circuit or a portion thereof.

[0018] FIG. 4 illustrates an implantable neurostimulation system 400 and portions of an environment in which system 400 may be used. System 400 includes an implantable system 422, an external system 402, and a telemetry link 426 providing for wireless communication

between implantable system 422 and external system 402. Implantable system 422 is illustrated in FIG. 4 as being implanted in the patient's body 499.

[0019] Implantable system 422 includes an implantable stimulator (also referred to as an implantable pulse generator, or IPG) 404, a lead system 424, and electrodes 406, which represent an embodiment of stimulation device 204, lead system 208, and electrodes 206, respectively. External system 402 represents an embodiment of programming device 302. In various embodiments, external system 402 includes one or more external (non-implantable) devices each allowing the user and/or the patient to communicate with implantable system 422. In some embodiments, external 402 includes a programming device intended for the user to initialize and adjust settings for implantable stimulator 404 and a remote control device intended for use by the patient. For example, the remote control device may allow the patient to turn implantable stimulator 404 on and off and/or adjust certain patient-programmable parameters of the plurality of stimulation parameters.

[0020] FIG. 5 illustrates an embodiment of implantable stimulator 404 and one or more leads 424 of an implantable neurostimulation system, such as implantable system 422. Implantable stimulator 404 may include a sensing circuit 530 that is optional and required only when the stimulator has a sensing capability, stimulation output circuit 212, a stimulation control circuit 514, an implant storage device 532, an implant telemetry circuit 534, and a power source 536. Sensing circuit 530, when included and needed, senses one or more physiological signals for purposes of patient monitoring and/or feedback control of the neurostimulation. Examples of the one or more physiological signals includes neural and other signals each indicative of a condition of the patient that is treated by the neurostimulation and/or a response of the patient to the delivery of the neurostimulation. Stimulation output circuit 212 is electrically connected to electrodes 406 through lead 424, and delivers each of the neurostimulation pulses through a set of electrodes selected from electrodes 406. Stimulation control circuit 514 represents an embodiment of stimulation control circuit 214 and controls the delivery of the neurostimulation pulses using the plurality of stimulation parameters specifying the pattern of the neurostimulation pulses. In one embodiment, stimulation control circuit 514 controls the delivery of the neurostimulation pulses using the one or more sensed physiological signals. Implant telemetry circuit 534 provides implantable stimulator 404 with wireless communication with another device such as a device of external system 402, including receiving values of the plurality of stimulation parameters from external system 402. Implant storage device 532 stores values of the plurality of stimulation parameters. Power source 536 provides implantable stimulator 404 with energy for its operation. In one embodiment, power source 536 includes a battery. In one embodiment, power source 536 includes a rechargeable battery and a battery charging circuit for charging the

rechargeable battery. Implant telemetry circuit 534 may also function as a power receiver that receives power transmitted from external system 402 through an inductive couple.

[0021] In various embodiments, sensing circuit 530 (if included), stimulation output circuit 212, stimulation control circuit 514, implant telemetry circuit 534, implant storage device 532, and power source 536 are encapsulated in a hermetically sealed implantable housing. In various embodiments, lead(s) 424 are implanted such that electrodes 406 are placed on and/or around one or more targets to which the neurostimulation pulses are to be delivered, while implantable stimulator 404 is subcutaneously implanted and connected to lead(s) 424 at the time of implantation.

[0022] FIG. 6 illustrates an embodiment of an external programmer 602 of an implantable neurostimulation system, such as external system 402. External programmer 602 represents an embodiment of programming device 302, and includes an external telemetry circuit 640, an external storage device 618, a programming control circuit 616, and a GUI 610.

[0023] External telemetry circuit 640 provides external programmer 602 with wireless communication with another device such as implantable stimulator 404 via telemetry link 426, including transmitting the plurality of stimulation parameters to implantable stimulator 404. In one embodiment, external telemetry circuit 640 also transmits power to implantable stimulator 404 through the inductive couple.

[0024] External storage device 618 stores a plurality of individually definable waveforms each selectable for use as a portion of the pattern of the neurostimulation pulses. In various embodiments, each waveform of the plurality of individually definable waveforms includes one or more pulses of the neurostimulation pulses, and may include one or more other waveforms of the plurality of individually definable waveforms. Examples of such waveforms include pulses, pulse blocks, pulse trains, and train groupings, and programs, as discussed below with reference to FIGS. 7 and 8. External storage device 618 also stores a plurality of individually definable fields. Each waveform of the plurality of individually definable waveforms is associated with one or more fields of the plurality of individually definable fields. Each field of the plurality of individually definable fields is defined by one or more electrodes of the plurality of electrodes through which a pulse of the neurostimulation pulses is delivered and a current distribution of the pulse over the one or more electrodes.

[0025] Programming control circuit 616 represents an embodiment of programming control circuit 316 and generates the plurality of stimulation parameters, which is to be transmitted to implantable stimulator 404, based on the pattern of the neurostimulation pulses. The pattern is defined using one or more waveforms selected from the plurality of individually definable waveforms stored in external storage device 618. In various embodiment, pro-

gramming control circuit 616 checks values of the plurality of stimulation parameters against safety rules to limit these values within constraints of the safety rules. In one embodiment, the safety rules are heuristic rules.

[0026] GUI 610 represents an embodiment of user interface 310 and allows the user to define the pattern of neurostimulation pulses and perform various other monitoring and programming tasks. GUI 610 includes a display screen 642, a user input device 644, and an interface control circuit 640. Display screen 642 may include any type of interactive or non-interactive screens, and user input device 644 may include any type of user input devices that supports the various functions discussed in this document, such as touchscreen, keyboard, keypad, touchpad, trackball, joystick, and mouse. In one embodiment, GUI 610 includes an interactive screen that displays a graphical representation of a stimulation waveform and allows the user to adjust the waveform by graphically editing the waveform and/or various building blocks of the waveform. GUI 610 may also allow the user to perform any other functions discussed in this document where graphical editing is suitable as may be appreciated by those skilled in the art.

[0027] Interface control circuit 640 controls the operation of GUI 610 including responding to various inputs received by user input device 644 and defining the one or more stimulation waveforms. Interface control circuit 640 includes neurostimulation control circuit 320.

[0028] In various embodiments, external programming device 602 has operation modes including a composition mode and a real-time programming mode. Under the composition mode (also known as the pulse pattern composition mode), GUI 610 is activated, while programming control circuit 616 is inactivated. Programming control circuit 616 does not dynamically updates values of the plurality of stimulation parameters in response to any change in the one or more stimulation waveforms. Under the real-time programming mode, both GUI 610 and programming control circuit 616 are activated. Programming control circuit 616 dynamically updates values of the plurality of stimulation parameters in response to changes in the set of one or more stimulation waveforms, and transmits the plurality of stimulation parameters with the updated values to implantable stimulator 404.

[0029] FIG. 7 is an illustration of an embodiment of a program creation area on a display screen of a GUI, such as on display screen 642 of GUI 610. In the illustrated embodiment, the program creation area is displayed in response to a program creation tab being selected, and includes a pulse train (PT) construction area and a train grouping (TG) construction area.

[0030] In the illustrated embodiment, a neurostimulation program includes one or more TGs. Each TG includes one or more PTs. An inter-train pause may be introduced between adjacent PTs in a TG. Each PT includes one or more pulse blocks (PBs). Order of PBs in each PT may be programmable, such as selectable from a predetermined order and a randomized. Number of rep-

etition of PBs in each PT may be programmable. Each PB includes a plurality of pulses. Programmable parameters associated with the PBs include pulse frequency, total pulses (TP), inter-block pause (IP), global amplitude, pulse shape, and lead (field) through which the pulses are delivered to the patient.

[0031] In the illustrated embodiment, the PT construction area includes a Load button and a Save button. The Load button allows for loading of a stored PT, such as from external storage device 618. The stored PT may be used as a template in creating a new PT. The Save button allows for saving a created PT, such as in external storage device 618. The TG construction area includes a Load button and a Save button. The Load button allows for loading of a stored TG, such as from external storage device 618. The stored TG may be used as a template in creating a new TG. The Save button allows for saving a created TG, such as in external storage device 618.

[0032] FIG. 8 is an illustration of an embodiment of a program scheduling area on a display screen of the GUI, such as on display screen 642 of GUI 610. In the illustrated embodiment, the program scheduling area is displayed in response to a program scheduling tab being selected, and allows for scheduling delivery of one or more neurostimulation programs.

[0033] In the illustrated embodiment, scheduling delivery for each program includes specifying time of delivery for each TG in a program. This includes specifying time of a day for starting the delivery of a TG and time of the day for ending the delivery of the TG. In an alternative embodiment, a predetermined duration for the delivery of the TG may be specified, in place of the time of the day for ending the delivery of the TG.

[0034] In the illustrated embodiment, scheduling delivery for each program further includes specifying a frequency of delivery of the program. This includes selecting weekly settings (days of a week on which the program is to be delivered), repetition (the program to be delivered weekly, biweekly, or monthly), and whether the program is enabled (selected for delivery). Multiple programs may be enabled simultaneously for simultaneous or concurrent delivery.

[0035] In the illustrated embodiment, the program scheduling area includes a Load button and a Save button. The Load button allows for loading of a stored scheduled program, such as from external storage device 618. The stored scheduled program may be used as a template in scheduling a new program. The Save button allows for saving a scheduled program, such as in external storage device 618.

[0036] FIG. 9 illustrates an embodiment of a neurostimulation program circuit 920 of an external programming device, such as the external programming device 602. Neurostimulation program circuit 920 is an embodiment of neurostimulation program circuit 320 and includes a program creation module 950 and a program scheduling module 952. In various embodiments, neurostimulation program circuit 920 displays a neurostim-

ulation program area on a display screen, such as display screen 642, in response to a neurostimulation programming command. For example, a user may initiate a programming session for an implantable stimulator by clicking on an icon to open a neurostimulation program window such as illustrated in FIGS 7 and 8. The neurostimulation program area or window includes the program creation tab and the program scheduling tab such as illustrated in FIGS 7 and 8. Neurostimulation program circuit 920 receives the program creation command when the program creation tab is selected (e.g., clicked on) by the user, and receives the program scheduling command when the program scheduling tab is selected (e.g., clicked on) by the user.

[0037] In response to the program creation command, program creation module 950 displays a PT construction area and TG construction area on the display screen. In the embodiment as illustrated in FIG. 7, the PT and TG construction areas are displayed simultaneously.

[0038] PT construction module 954 allows construction of one or more PTs using the PT construction area. In various embodiments, PT construction module 954 allows for (1) adding a PB to a PT and subtracting a PB from the PT, with the PT construction area dynamically updated to reflect the change; (2) cycling through and/or defining different PTs; (3) assigning leads and electrodes (stimulation field) and pulse shape to each PT; (4) specifying cathode(s) and anode(s), such as by clicking on a PB symbol displayed as illustrated in FIG. 7; and (5) loading a PT from the PT library, and saving a newly created PT in the PT library.

[0039] TG construction module 965 allows construction of one or more TGs using the TG scheduling area. In various embodiments, TG construction module 954 allows for (1) cycling through and/or defining different TGs; (2) adding one or more PTs and/or stimulation pauses (SPs) to the TG; (3) modify the order of the PTs and/or SPs in the TG, such as by clicking and dragging; (4) PTs and SPs snap to circle; (5) randomization of the order of PBs within a PT; and (6) loading a TG from the TG library, and saving a newly created TG in the TG library.

[0040] In response to the programming scheduling command, program scheduling module 952 displays the program scheduling area on the display screen. In various embodiments, TG construction module 954 allows for (1) specification of at least a starting time for each TG in a neurostimulation program; (2) allow multiple programs to be selected to be delivered simultaneously; and loading a program from the program library, and saving a newly scheduled program in the program library.

[0041] FIG. 10 illustrates an embodiment of a method 1000 for creating and scheduling neurostimulation programs. In one embodiment, method 1000 is performed using system 100, including the various embodiments of its components as discussed in this document. For example, GUI 610 and neurostimulation program circuit 320 or 920 may be configured for performing method 1000.

[0042] At 1002, a neurostimulation program area is dis-

played on a GUI. The neurostimulation program area allows a user such as a physician or other caregiver to create building blocks for one or more neurostimulation programs and to schedule delivery of the one or more programs. The programs each specify a pattern of the neurostimulation pulses. The one or more building blocks includes one or more PBs each including a plurality of pulses of the neurostimulation pulses, one or more PTs each including one or more PBs, and one or more TGs each including one or more PTs, as discussed above with reference to FIGS. 7 and 8.

[0043] At 1004, a program creation command or a program scheduling command is received from the user using the GUI. In response to a program creation command being received at 1004, a PT construction area is displayed at 1006, selection of a PT from the one or more PTs is received from the user at 1008, the selected PT is displayed in the PT construction area at 1010, and definition of the selected PT as a sequence of PB(s) is allowed to be performed by the user. Also in response to the program creation command being received at 1004, a TG construction area is displayed at 1014, selection of a TG from the one or more TGs is received from the user at 1016, the selected TG is displayed in the TG construction area at 1018, and definition of the selected TG as a sequence of PT(s) is allowed to be performed by the user. In various embodiments, when defining a TG, the user is allowed to specify the number of repetitions for the one or more PBs of each PT in the TG. In various embodiments, when defining the TG, the user is also allowed to specify an order (including a random order) of the one or more PBs of each PT in the TG.

[0044] In response to a program scheduling command being received at 1004, a program scheduling area is displayed at 1022, selection of a program from the one or more programs is received from the user at 1024, the selected program is displayed in the program scheduling area at 1026, and scheduling of the selected program is allowed to be performed by the user at 1028. In various embodiments, scheduling a program includes specifying time of delivery for each TG in the program. In various embodiments, the user is also allowed to specify a frequency of delivery of the program. In various embodiments, the user is allowed to select multiple programs to be run simultaneously.

[0045] At 1030, stimulation parameters are generated based on the scheduled program(s). In various embodiments, the stimulation parameters are transmitted to an implantable medical device, such as implantable stimulator 404, and used to control delivery of neurostimulation pulses from the implantable medical device.

[0046] It is to be understood that the above detailed description is intended to be illustrative, and not restrictive. Other embodiments will be apparent to those of skill in the art upon reading and understanding the above description. The scope of the invention should, therefore, be determined with reference to the appended claims, along with the full scope of equivalents to which such

claims are entitled.

Claims

1. A neurostimulation system, comprising:

a programming control circuit configured to generate a plurality of stimulation parameters controlling delivery of neurostimulation pulses according to one or more neurostimulation programs each specifying a pattern of the neurostimulation pulses; and

a user interface coupled to the programming control circuit and including a display screen, a user input device, and a neurostimulation program circuit coupled to the display screen and the user input device, the neurostimulation program circuit including a program creation module configured to create building blocks for the one or more neurostimulation programs and a program scheduling module configured to schedule delivery of the one or more neurostimulation programs, the program creation module including:

a pulse train (PT) construction module configured to allow for construction of PTs using the display screen and the user input device, the PTs each including one or more pulse blocks (PBs) each including a plurality of pulses of the neurostimulation pulses; and

a train grouping (TG) construction module configured to allow for construction of TGs using the display screen and the user input device, the TGs each including one or more PTs, the construction of TGs including receiving an order and a number of repetitions of the one or more PBs in each PT of the one or more PTs,

the program scheduling module configured to allow for temporal arrangement of one or more TGs selected from the constructed TGs for each program of the one or more neurostimulation programs using the display screen and the user input device and to allow for scheduling of one or more delivery times for the each program using the display screen and the user input device.

2. The system according to claim 1, wherein the display screen comprises a touchscreen, and a portion of the user input device is integrated into the touchscreen.

3. The system according to any of the preceding claims, wherein the neurostimulation program circuit is con-

- figured to display a neurostimulation program area on the screen in response to a neurostimulation programming command and to receive user commands using the user input device, the user commands including a program creation command and a program scheduling command.
4. The system according to claim 3, wherein the neurostimulation program circuit is configured to display a program creation tab and a program scheduling tab on the screen, to receive the program creation command when the program creation tab is selected, and to receive the program scheduling command when the program scheduling tab is selected.
 5. The system according to any of claims 3 and 4, wherein the program creation module is configured to display a PT construction area and a TG construction area on the screen in response to the program creation command.
 6. The system according to claim 5, wherein the PT construction module is configured to display a PT of the PTs in the PT construction area and to allow for definition of the plurality of pulses in each PB of the one or more PBs of the PT.
 7. The system according to claim 6, wherein the TG construction module is configured to display a TG of the TGs in the TG construction area and to allow for definition of the TG as a sequence of PTs each selected from the PTs.
 8. The system according to any of claims 3 to 7, wherein the program scheduling module is configured to display a program scheduling area on the screen in response to the program scheduling command and to allow for scheduling of each program of the one or more neurostimulation programs including time of delivery for each TG of the one or more TGs in the each program in the program scheduling area.
 9. The system according to claim 8, wherein the program scheduling module is configured to allow for specification of a frequency of delivery of the each program.
 10. The system according to any of claims 8 and 9, wherein the program scheduling module is configured to allow scheduling on a plurality of programs of the one or more neurostimulation programs to be delivered simultaneously.
 11. The system according to any of the preceding claims, further comprising a storage device including a PT library having one or more stored PTs, and the PT construction module is configured to allow for use of the one or more stored PTs in the construction of the

PTs and to allow each newly constructed PT of the PTs to be added to the one or more stored PTs in the PT library.

12. The system according to claim 11, wherein the storage device further comprises a TG library having one or more stored TGs, and the TG construction module is configured to allow for use of the one or more stored TGs in the construction of the TGs and to allow each newly constructed TG of the TGs to be added to the one or more stored TGs in the TG library.
13. The system according to any of claims 11 and 12, wherein the storage device further comprises a program library having one or more scheduled programs, and the program scheduling module is configured to allow for scheduling a new program by rescheduling a scheduled program of the one or more scheduled programs and to allow each newly scheduled program to be added to the one or more scheduled programs in the program library.

25 Patentansprüche

1. Neurostimulationssystem, das aufweist:

eine Programmiersteuerschaltung, die so konfiguriert ist, dass sie mehrere Stimulationsparameter erzeugt, die die Zufuhr von Neurostimulationsimpulsen gemäß einem oder mehreren Neurostimulationsprogrammen steuern, die jeweils ein Muster der Neurostimulationsimpulse festlegen; und
eine Benutzerschnittstelle, die mit der Programmiersteuerschaltung gekoppelt ist und einen Anzeigebildschirm, ein Benutzereingabegerät und eine Neurostimulationsprogrammschaltung aufweist, die mit dem Anzeigebildschirm und dem Benutzereingabegerät gekoppelt ist, wobei die Neurostimulationsprogrammschaltung aufweist: ein Programmmerzeugungsmodul, das so konfiguriert ist, dass es Bausteine für das eine oder die mehreren Neurostimulationsprogramme erzeugt, und ein Programmzeitplanungsmodul, das so konfiguriert ist, dass es die Zufuhr des einen oder der mehreren Neurostimulationsprogramme steuert, wobei das Programmmerzeugungsmodul aufweist:

ein Impulsfolgen-(PT)-Erstellungsmodul, das so konfiguriert ist, dass es die Erstellung von PTs mit Hilfe des Anzeigebildschirms und des Benutzereingabegeräts ermöglicht, wobei die PTs jeweils einen oder mehrere Impulsblöcke (PBs) aufweisen, die jeweils mehrere Impulse der Neu-

rostimulationsimpulse aufweisen; und ein Folgenreihenfolge-(TG)-Erstellungsmodul, das so konfiguriert ist, dass es die Erstellung von TGs mit Hilfe des Anzeigebildschirms und des Benutzereingabegeräts ermöglicht, wobei die TGs jeweils eine oder mehrere PTs aufweisen und die Erstellung von TGs aufweist: Empfangen einer Reihenfolge und einer Anzahl von Wiederholungen des einen oder der mehreren PBs in jeder PT der einen oder der mehreren PTs,

wobei das Programmzeitplanungsmodul so konfiguriert ist, dass es die zeitliche Anordnung einer oder mehrerer TGs, die aus den erstellten TGs ausgewählt sind, für jedes Programm des einen oder der mehreren Neurostimulationsprogramme mit Hilfe des Anzeigebildschirms und des Benutzereingabegeräts ermöglicht und die Zeitplanung einer oder mehrerer Zufuhrzeiten für jedes Programm mit Hilfe des Anzeigebildschirms und des Benutzereingabegeräts ermöglicht.

2. System nach Anspruch 1, wobei der Anzeigebildschirm einen Touchscreen aufweist und ein Abschnitt des Benutzereingabegeräts in den Touchscreen integriert ist.
3. System nach einem der vorstehenden Ansprüche, wobei die Neurostimulationsprogrammumschaltung so konfiguriert ist, dass sie einen Neurostimulationsprogrammumschaltungsbereich auf dem Bildschirm als Reaktion auf einen Neurostimulationsprogrammumschaltungsbefehl anzeigt und Benutzerbefehle mit Hilfe des Benutzereingabegeräts empfängt, wobei die Benutzerbefehle einen Programmumschaltungsbefehl und einen Programmzeitplanungsmodulbefehl aufweisen.
4. System nach Anspruch 3, wobei die Neurostimulationsprogrammumschaltung so konfiguriert ist, dass sie einen Programmumschaltungsbereich-Tab und einen Programmzeitplanungs-Tab auf dem Bildschirm anzeigt, um den Programmumschaltungsbefehl zu empfangen, wenn der Programmumschaltungsbereich-Tab ausgewählt wird, und um den Programmzeitplanungsmodulbefehl zu empfangen, wenn der Programmzeitplanungs-Tab ausgewählt wird.
5. System nach Anspruch 3 oder 4, wobei das Programmumschaltungsbereichmodul so konfiguriert ist, dass es einen PT-Erstellungsbereich und einen TG-Erstellungsbereich auf dem Bildschirm als Reaktion auf den Programmumschaltungsbefehl anzeigt.
6. System nach Anspruch 5, wobei das PT-Erstellungsmodul so konfiguriert ist, dass es eine PT der PTs

im PT-Erstellungsbereich anzeigt und die Festlegung der mehreren Impulse in jedem PB des einen oder der mehreren PBs der PT ermöglicht.

7. System nach Anspruch 6, wobei das TG-Erstellungsmodul so konfiguriert ist, dass es eine TG der TGs im TG-Erstellungsbereich anzeigt und die Festlegung der TG als Abfolge von PTs ermöglicht, die jeweils aus den PTs ausgewählt sind.
8. System nach einem der Ansprüche 3 bis 7, wobei das Programmzeitplanungsmodul so konfiguriert ist, dass es einen Programmzeitplanungsmodulbereich auf dem Bildschirm als Reaktion auf den Programmzeitplanungsmodulbefehl anzeigt und die Zeitplanung jedes Programms des einen oder der mehreren Neurostimulationsprogramme ermöglicht, darunter die Zufuhrzeit für jede TG der einen oder der mehreren TGs in jedem Programm im Programmzeitplanungsmodulbereich.
9. System nach Anspruch 8, wobei das Programmzeitplanungsmodul so konfiguriert ist, dass es die Festlegung einer Zufuhrhäufigkeit jedes Programms ermöglicht.
10. System nach Anspruch 8 oder 9, wobei das Programmzeitplanungsmodul so konfiguriert ist, dass es die Zeitplanung zu mehreren Programmen des einen oder der mehreren Neurostimulationsprogramme so ermöglicht, dass sie gleichzeitig zugeführt werden.
11. System nach einem der vorstehenden Ansprüche, ferner mit einem Speicherbauelement, das eine PT-Bibliothek mit einer oder mehreren gespeicherten PTs aufweist, und das PT-Erstellungsmodul so konfiguriert ist, dass es die Verwendung der einen oder der mehreren gespeicherten PTs bei der Erstellung der PTs ermöglicht und ermöglicht, dass jede neu erstellte PT der PTs der einen oder der mehreren gespeicherten PTs in der PT-Bibliothek zugefügt wird.
12. System nach Anspruch 11, wobei das Speicherbauelement ferner eine TG-Bibliothek mit einer oder mehreren gespeicherten TGs aufweist und das TG-Erstellungsmodul so konfiguriert ist, dass es die Verwendung der einen oder der mehreren gespeicherten TGs bei der Erstellung der TGs ermöglicht und ermöglicht, dass jede neu erstellte TG der TGs der einen oder der mehreren gespeicherten TGs in der TG-Bibliothek zugefügt wird.
13. System nach Anspruch 11 oder 12, wobei das Speicherbauelement ferner eine Programm-Bibliothek mit einem oder mehreren zeitgeplanten Programmen aufweist und das Programmzeitplanungs-

modul so konfiguriert ist, dass es die Zeitplanung eines neuen Programms durch Neuplanung eines zeitgeplanten Programms des einen oder der mehreren zeitgeplanten Programme ermöglicht und ermöglicht, dass jedes neu zeitgeplante Programm dem einen oder den mehreren zeitgeplanten Programmen in der Programmbibliothek zugefügt wird.

Revendications

1. Système de neurostimulation, comprenant :

un circuit de commande de programmation configuré pour produire une pluralité de paramètres de stimulation commandant la fourniture d'impulsions de neurostimulation selon un ou plusieurs programmes de neurostimulation spécifiant chacun une configuration des impulsions de neurostimulation ; et

une interface utilisateur couplée au circuit de commande de programmation et incluant un écran d'affichage, un dispositif d'entrée utilisateur, et un circuit de programmes de neurostimulation couplé à l'écran d'affichage et au dispositif d'entrée utilisateur, le circuit de programmes de neurostimulation incluant un module de création de programmes configuré pour créer des blocs de construction pour les un ou plusieurs programmes de neurostimulation et un module de planification de programmes configuré pour planifier la fourniture des un ou plusieurs programmes de neurostimulation, le module de création de programmes incluant :

un module de construction de trains d'impulsions (TI) configuré pour permettre la construction de TI au moyen de l'écran d'affichage et du dispositif d'entrée utilisateur, les TI incluant chacun un ou plusieurs blocs d'impulsions (BI) incluant chacun une pluralité d'impulsions des impulsions de neurostimulation ; et

un module de construction de groupements de trains (GT) configuré pour permettre la construction de GT au moyen de l'écran d'affichage et du dispositif d'entrée utilisateur, les GT incluant chacun un ou plusieurs TI, la construction de GT incluant la réception d'un ordre et d'un nombre de répétitions des un ou plusieurs BI dans chaque TI des un ou plusieurs TI,

le module de planification de programmes configuré pour permettre l'agencement temporel d'un ou plusieurs GT choisis parmi les GT construits pour chaque programme des un ou plusieurs programmes de neurostimulation au moyen de l'écran d'afficha-

ge et du dispositif d'entrée utilisateur et pour permettre la planification d'un ou plusieurs moments de fourniture pour chaque programme au moyen de l'écran d'affichage et du dispositif d'entrée utilisateur.

5

10

15

20

25

30

35

40

45

50

55

2. Système selon la revendication 1, où l'écran d'affichage comprend un écran tactile, et une partie du dispositif d'entrée utilisateur est intégrée dans l'écran tactile.

3. Système selon l'une quelconque des revendications précédentes, où le circuit de programmes de neurostimulation est configuré pour afficher une zone de programmes de neurostimulation sur l'écran en réponse à une commande de programmation de neurostimulation et pour recevoir des commandes utilisateur au moyen du dispositif d'entrée utilisateur, les commandes utilisateur incluant une commande de création de programmes et une commande de planification de programmes.

4. Système selon la revendication 3, où le circuit de programmes de neurostimulation est configuré pour afficher un onglet de création de programmes et un onglet de planification de programmes sur l'écran, pour recevoir la commande de création de programmes quand l'onglet de création de programmes est sélectionné, et pour recevoir la commande de planification de programmes quand l'onglet de planification de programmes est sélectionné.

5. Système selon l'une quelconque des revendications 3 et 4, où le module de création de programmes est configuré pour afficher une zone de construction de TI et une zone de construction de GT sur l'écran en réponse à la commande de création de programmes.

6. Système selon la revendication 5, où le module de construction de TI est configuré pour afficher un TI des TI dans la zone de construction de TI et pour permettre la définition de la pluralité d'impulsions dans chaque BI des un ou plusieurs BI du TI.

7. Système selon la revendication 6, où le module de construction de GT est configuré pour afficher un GT des GT dans la zone de construction de GT et pour permettre la définition du GT comme une séquence de TI choisis chacun parmi les TI.

8. Système selon l'une quelconque des revendications 3 à 7, où le module de planification de programmes est configuré pour afficher une zone de planification de programmes sur l'écran en réponse à la commande de planification de programmes et pour permettre la planification de chaque programme des un ou plusieurs programmes de neurostimulation incluant le moment de fourniture pour chaque GT des un ou

plusieurs GT dans chaque programme dans la zone de planification de programmes.

9. Système selon la revendication 8, où le module de planification de programmes est configuré pour permettre la spécification d'une fréquence de fourniture de chaque programme. 5
10. Système selon l'une quelconque des revendications 8 et 9, où le module de planification de programmes est configuré pour permettre la planification d'une pluralité de programmes des un ou plusieurs programmes de neurostimulation destinés à être fournis simultanément. 10
15
11. Système selon l'une quelconque des revendications précédentes, comprenant en outre un dispositif de stockage incluant une banque de TI ayant un ou plusieurs TI stockés, et le module de construction de TI est configuré pour permettre l'utilisation des un ou plusieurs TI stockés dans la construction des TI et pour permettre à chaque TI des TI nouvellement construit d'être ajouté aux un ou plusieurs TI stockés dans la banque de TI. 20
25
12. Système selon la revendication 11, où le dispositif de stockage comprend en outre une banque de GT ayant un ou plusieurs GT stockés, et le module de construction de GT est configuré pour permettre l'utilisation des un ou plusieurs GT stockés dans la construction des GT et pour permettre à chaque GT des GT nouvellement construit d'être ajouté aux un ou plusieurs GT stockés dans la banque de GT. 30
13. Système selon l'une quelconque des revendications 11 et 12, où le dispositif de stockage comprend en outre une banque de programmes ayant un ou plusieurs programmes planifiés, et le module de planification de programmes est configuré pour permettre la planification d'un nouveau programme par replanification d'un programme planifié des un ou plusieurs programmes planifiés et pour permettre à chaque programme nouvellement planifié d'être ajouté aux un ou plusieurs programmes planifiés dans la banque de programmes. 35
40
45

50

55

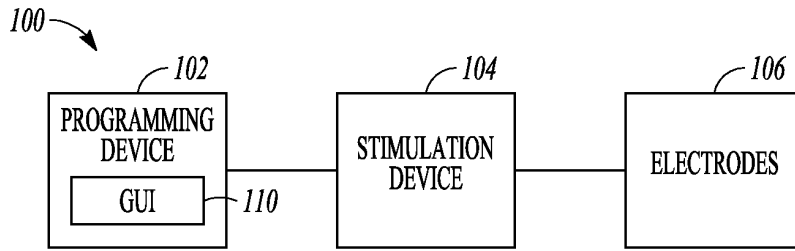

FIG. 1

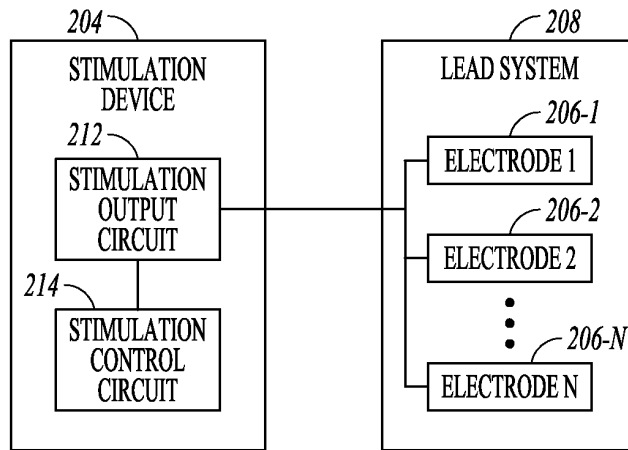

FIG. 2

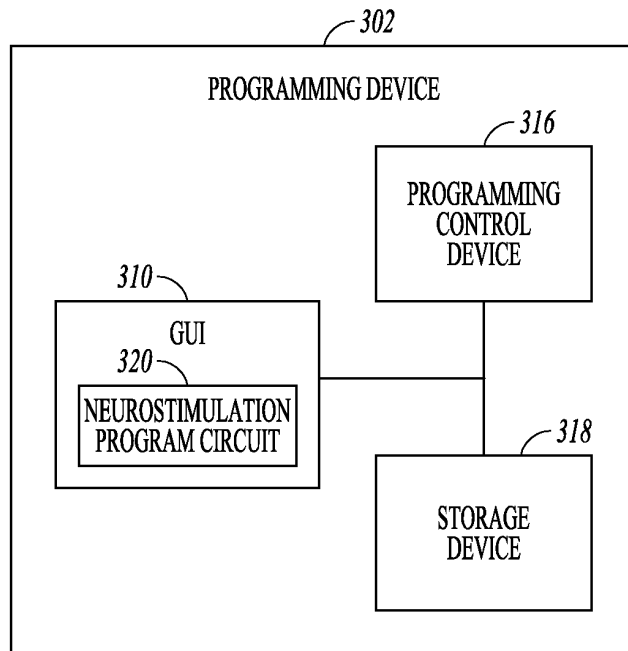

FIG. 3

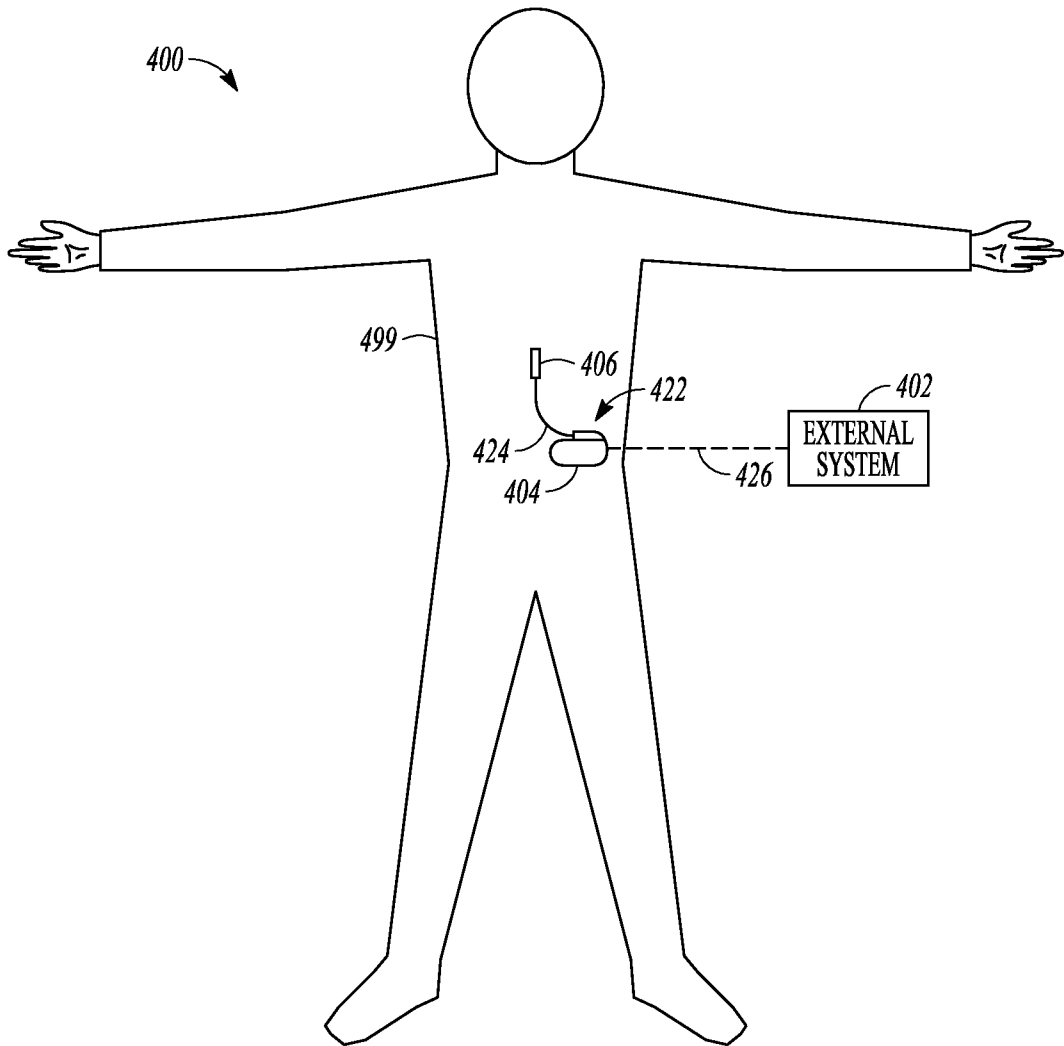

FIG. 4

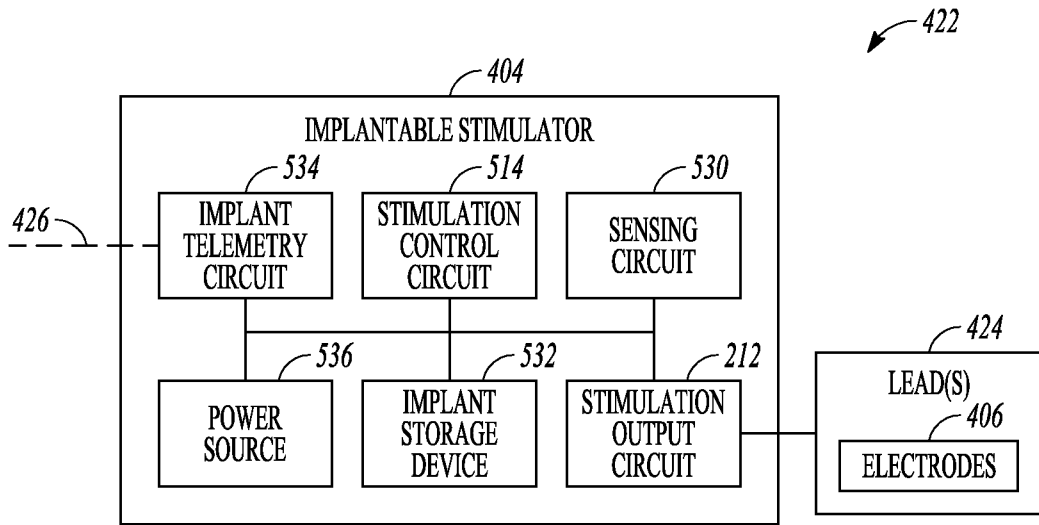

FIG. 5

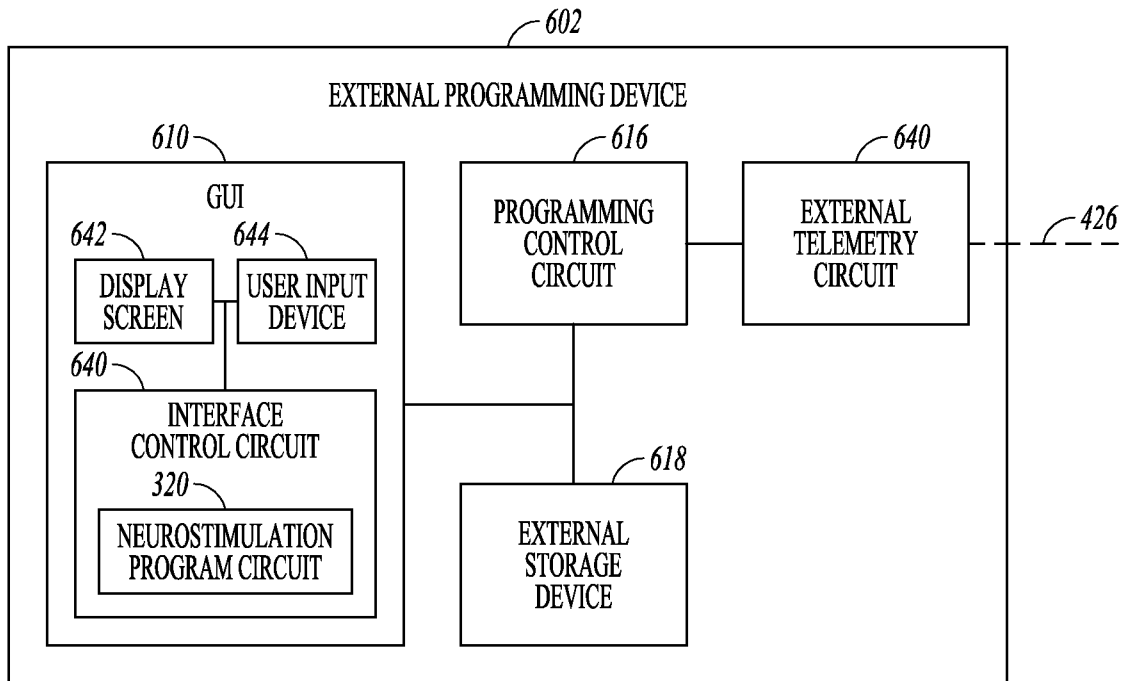

FIG. 6

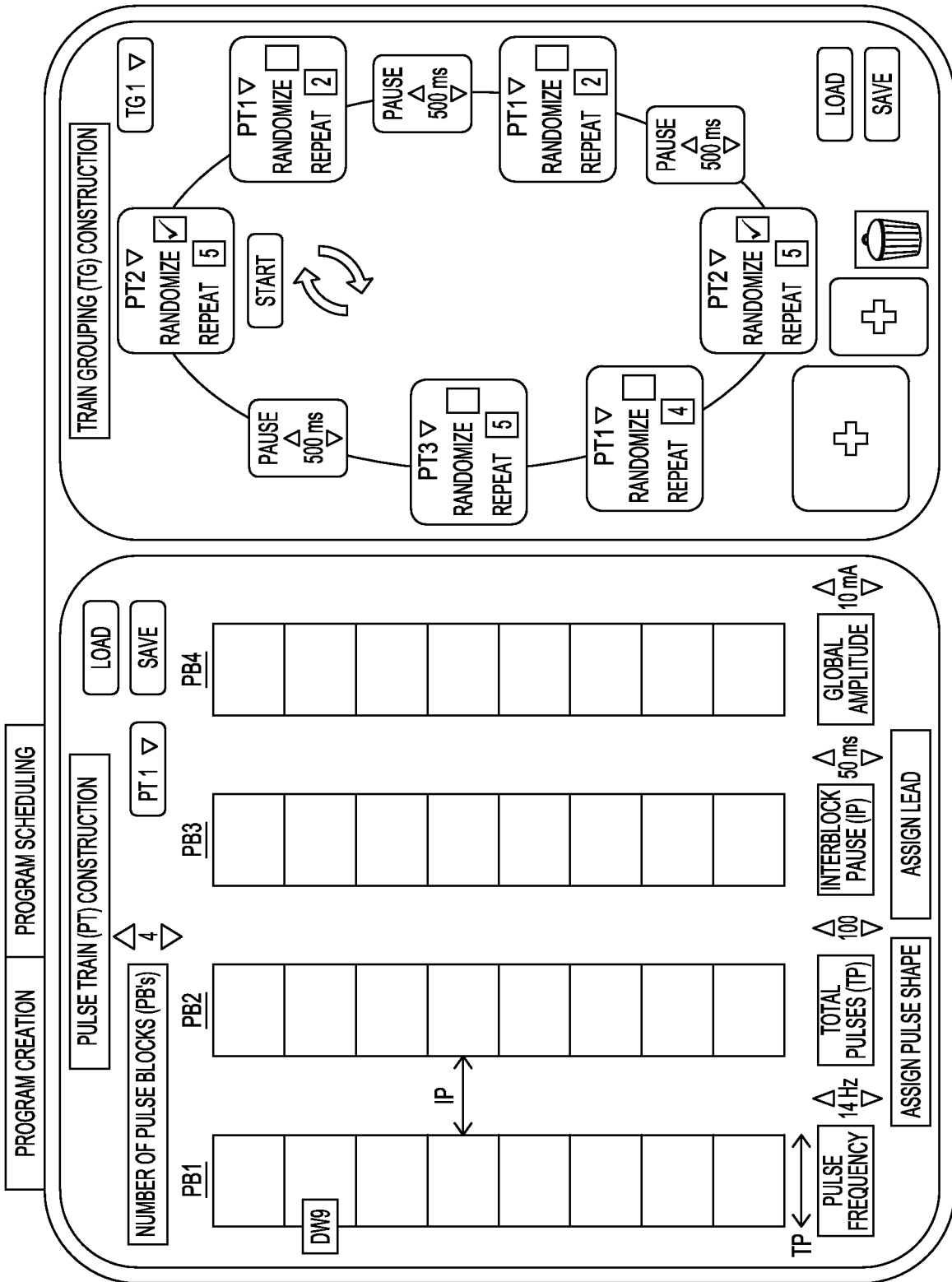

FIG. 7

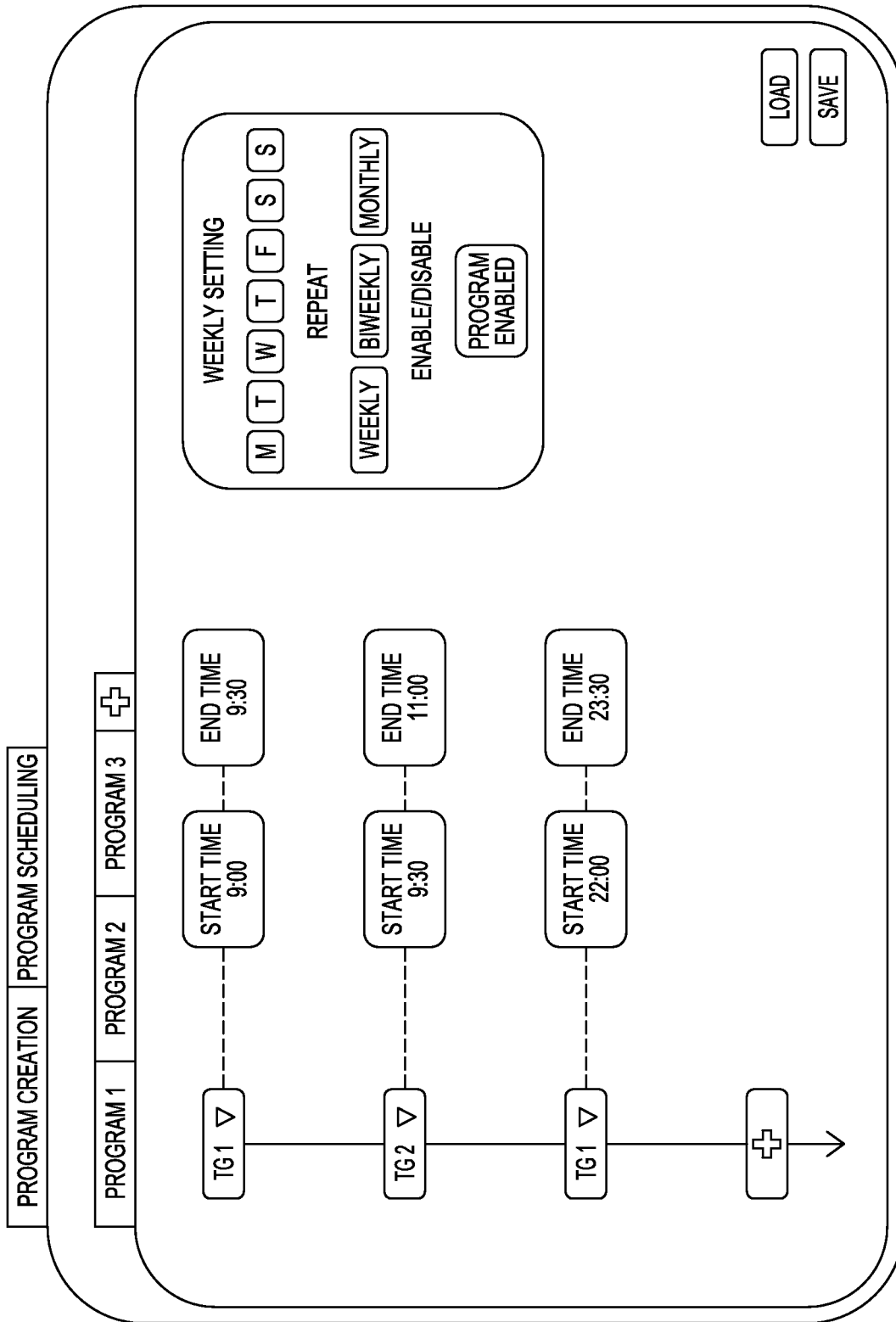

FIG. 8

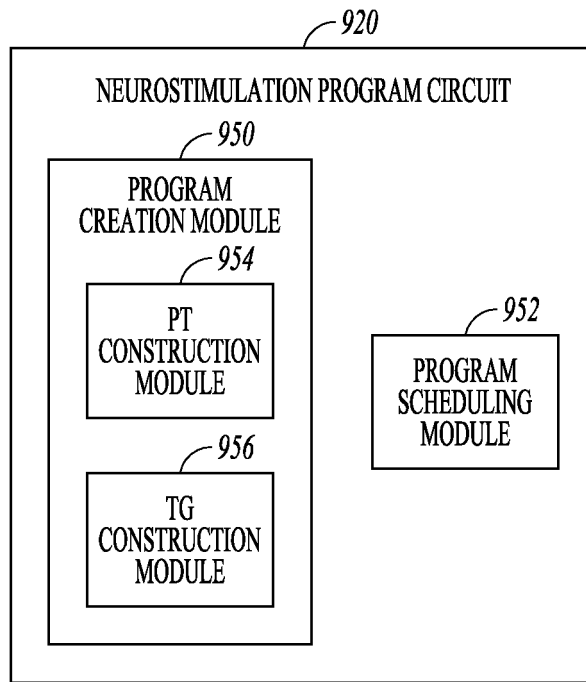

FIG. 9

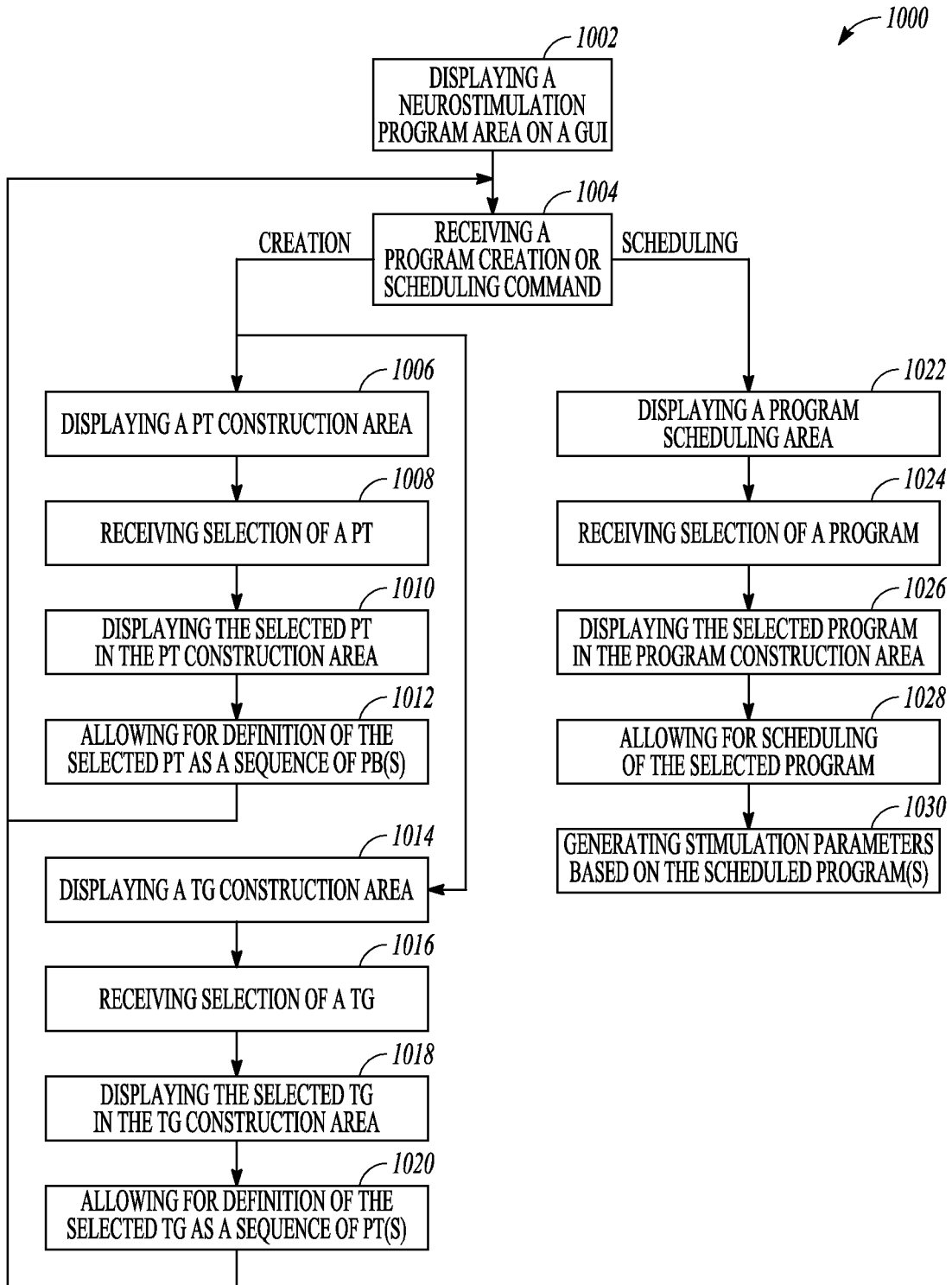

FIG. 10

REFERENCES CITED IN THE DESCRIPTION

This list of references cited by the applicant is for the reader's convenience only. It does not form part of the European patent document. Even though great care has been taken in compiling the references, errors or omissions cannot be excluded and the EPO disclaims all liability in this regard.

Patent documents cited in the description

- US 2013053926 A [0004]

专利名称(译)	用于定制图案化电刺激的用户界面		
公开(公告)号	EP3328481B1	公开(公告)日	2019-05-15
申请号	EP2016732137	申请日	2016-06-13
[标]申请(专利权)人(译)	波士顿科学神经调制公司		
申请(专利权)人(译)	波士顿科学神经调节CORPORATION		
当前申请(专利权)人(译)	波士顿科学神经调节CORPORATION		
[标]发明人	WECHTER DAVID ERNEST		
发明人	WECHTER, DAVID ERNEST		
IPC分类号	A61N1/05 A61B5/00 A61N1/36 G16H40/63 G06F19/00		
CPC分类号	A61B5/04001 A61B5/4035 A61B5/7475 A61N1/0556 A61N1/36053 A61N1/36114 A61N1/37247 A61N1/37264 G16H40/63 G06F3/0483 G06F3/04842 G06F3/0488		
优先权	62/198957 2015-07-30 US		
其他公开文献	EP3328481A1		
外部链接	Espacenet		

摘要(译)

神经刺激系统包括编程控制电路和用户界面。编程控制电路可以被配置为根据一个或多个神经刺激程序产生控制神经刺激脉冲的递送的多个刺激参数，每个神经刺激程序指定神经刺激脉冲的模式。用户界面包括显示屏，用户输入设备和神经刺激程序电路。神经刺激程序电路可以被配置为允许构建一个或多个神经刺激程序的一个或多个脉冲序列（PT）和一个或多个列车分组（TG），并且允许调度一个或多个神经刺激的递送。程序，使用显示屏和用户输入设备。每个PT包括一个或多个脉冲块，每个脉冲块包括多个神经刺激脉冲。每个TG包括一个或多个PT。



FIG. 1

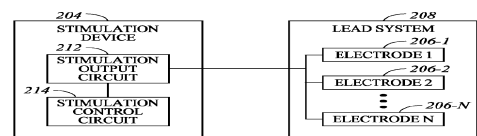

FIG. 2

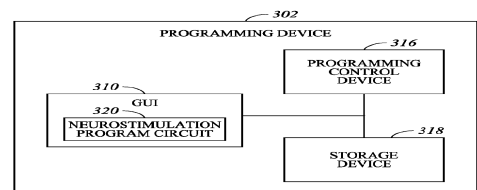

FIG. 3