

(19)



(11)

EP 3 243 476 B1

(12)

EUROPEAN PATENT SPECIFICATION

(45) Date of publication and mention of the grant of the patent:
06.11.2019 Bulletin 2019/45

(51) Int Cl.:
A61B 34/30 ^(2016.01) **A61B 5/06** ^(2006.01)
A61B 5/00 ^(2006.01) **A61B 34/00** ^(2016.01)
A61M 25/01 ^(2006.01) **A61B 34/10** ^(2016.01)

(21) Application number: **17177593.5**

(22) Date of filing: **23.03.2015**

(54) SYSTEMS AND DEVICES FOR CATHETER DRIVING INSTINCTIVENESS

SYSTEME UND VORRICHTUNGEN FÜR KATHETER ZUR FÖRDERUNG VON INSTINKTHANDLUNGEN

SYSTÈMES ET DISPOSITIFS POUR LE GUIDAGE INSTINCTIF D'UN CATHÉTER

(84) Designated Contracting States:
AL AT BE BG CH CY CZ DE DK EE ES FI FR GB GR HR HU IE IS IT LI LT LU LV MC MK MT NL NO PL PT RO RS SE SI SK SM TR

(30) Priority: **24.03.2014 US 201461969496 P**
23.04.2014 US 201461983191 P

(43) Date of publication of application:
15.11.2017 Bulletin 2017/46

(62) Document number(s) of the earlier application(s) in accordance with Art. 76 EPC:
15160417.0 / 2 923 669

(73) Proprietor: **Auris Health, Inc.**
Redwood City, CA 94065 (US)

(72) Inventors:

- **PARK, June**
San Jose, CA 95129 (US)
- **D'AMBROSIO, Ray**
Fremont, CA 94538 (US)
- **WALKER, Sean P.**
Fremont, CA 94555 (US)

(74) Representative: **Clark, Jane Anne et al**
Mathys & Squire LLP
The Shard
32 London Bridge Street
London SE1 9SG (GB)

(56) References cited:
EP-A1- 2 158 834 **US-A- 5 280 781**
US-A- 5 899 851 **US-A1- 2002 161 280**
US-A1- 2008 108 870 **US-A1- 2008 159 653**
US-A1- 2011 196 199

EP 3 243 476 B1

Note: Within nine months of the publication of the mention of the grant of the European patent in the European Patent Bulletin, any person may give notice to the European Patent Office of opposition to that patent, in accordance with the Implementing Regulations. Notice of opposition shall not be deemed to have been filed until the opposition fee has been paid. (Art. 99(1) European Patent Convention).

Description**TECHNICAL FIELD**

5 [0001] The present disclosure relates generally to a robotic surgical system, and more particularly to systems and devices for improving instinctive control of catheter movement in a patient's anatomy.

BACKGROUND

10 [0002] Robotic surgical systems and devices are well suited for use in performing minimally invasive medical procedures, as opposed to conventional techniques that may require large incisions to open the patient's body cavity to provide the surgeon with access to internal organs. Advances in technology have led to significant changes in the field of medical surgery, such that less invasive surgical procedures, in particular minimally invasive surgery (MIS) procedures, are increasingly popular.

15 [0003] MIS is generally defined as surgery that is performed by entering the body through the skin, body cavity, or an anatomical opening, using small incisions rather than large, open incisions in the body. With MIS, it is possible to reduce operative trauma to the patient, hospitalization time, pain and scarring, incidence of complications related to surgical trauma, costs, and recovery time.

20 [0004] Special medical equipment may be used to perform an MIS procedure. Typically, a surgeon inserts small tubes or ports into a patient and uses endoscopes or laparoscopes having a fiber optic camera, light source, and/or miniaturized surgical instruments. A robotic catheter system attempts to facilitate this process by controlling the catheter tip with better precision and improved instinctive control. The goal of instinctive driving of a catheter or other elongate member is to move the catheter tip as the operator intends when the catheter is manipulated and observed by the operator remotely. For example, the orientation of the model image of the catheter is adjusted to match that of a real image of
25 the catheter, so that a command to move the model catheter to the right results in the actual catheter tip moving to the right in the reference frame of the real image of the catheter.

[0005] However, current user interface tools and user interface devices still lack features that facilitate instinctive driving. For example, a user may desire to navigate a catheter to the right, but it may be unclear to the user which pullwire should be manipulated, especially if the catheter is experiencing some degree of roll or twist. Further, correcting or accounting for roll or twist poses challenges to instinctive driving. For example, it may not be apparent to the user if roll
30 has occurred or what direction the catheter tip will head in after catheter roll has occurred.

[0006] In some cases, sensorizing the catheter may facilitate instinctive driving. For example, Fiber Optic Shape Sensing and Localization (FOSSL) or electromagnetic sensing may be used to sense the shape of a flexible body, such as the catheter during an MIS procedure, to permit visualization of the catheter in the patient's anatomy. The catheter position and orientation may be transmitted to a visual display to allow an operator (e.g., a surgeon) to analyze the images and make decisions to navigate through the patient's anatomy instinctively. However, this process is not straight-forward and generally requires the operator to interpret multiple two-dimensional images acquired in real time (e.g.,
35 fluoroscopic images) in three-dimensional space before engaging in catheter manipulation.

[0007] Accordingly, there is a need for systems and methods to identify and/or correct catheter roll and to simplify user interface commands for more intuitive controls in order to facilitate navigation through a patient's anatomy.

40 [0008] US2011/196199 describes a robotic endoscope system in which the orientation of a captured camera view at a distal tip of the endoscope and displayed on a screen viewable by an operator of the endoscope is automatically maintained at an orientation associated with a setpoint so as not to disorientate the operator as the endoscope is moved, flexed and its tip turned in different orientations. A processor generates a current commanded state of the tip from operator input and modifies it to maintain the setpoint roll orientation. To generate the modified current commanded state, the current commanded roll position and velocity are constrained to be a modified current commanded roll position and velocity that have been modified according to a roll angular adjustment indicated by a prior process period commanded state of the tip and the setpoint. The processor then commands the robotic endoscope to be driven to the modified
45 commanded state.

50

BRIEF SUMMARY

[0009] The present invention is set out in the appended claims.

55 [0010] In one example, a robotic catheter system may include: a flexible catheter having a proximal end, a distal end, and an articulating portion at the distal end; a sensor coupled with the flexible catheter at or near the distal end; a visual display for displaying an image of at least part of the flexible catheter; a processor for generating a virtual indicator displayed on the image of the flexible catheter, where the virtual indicator indicates a direction of articulation and/or an amount of articulation of the articulating portion of the catheter; and a controller coupled with the proximal end of the

flexible catheter to receive a user input and articulate the articulating portion of the catheter in response to the user input.

5 [0011] In some examples, the controller may include a first control configured to receive an additional user input and rotate the virtual indicator about a longitudinal axis of the catheter in response to the additional user input, without rotating the catheter. For example, the first control may be a control column configured to rotate about an axis relative to a base of the controller, where rotation of the virtual indicator corresponds to rotation of the control column. In some examples, for example, rotating the control column in a clockwise direction rotates the virtual indicator in a clockwise direction when the elongate member points into the visual display, and rotating the control column in the clockwise direction rotates the virtual indicator in a counterclockwise direction when the elongate member points out of the visual display. Optionally, the system may further include an actuator coupled to the catheter for articulating the articulation portion, and the controller may include a second control coupled to the actuator for articulating the articulation portion.

10 [0012] In some examples, the virtual indicator corresponds to the controller, and inputting a user input into the controller causes the processor to generate the virtual indicator indicating a direction of movement of the articulation portion of the flexible catheter. In some examples, the virtual indicator corresponds to an actuator coupled to the catheter, and engaging the actuator articulates the articulating portion in a direction of the virtual indicator. In some examples, the virtual indicator may include a first graphic symbol corresponding to a first actuator coupled to the flexible catheter, a second graphic symbol corresponding to a second actuator coupled to the flexible catheter, and a third graphic symbol corresponding to a third actuator coupled to the flexible catheter. These graphic symbols may be equally spaced along a circumference of the image of the flexible catheter displayed on the visual display. In various examples the graphic symbols may be arrows, stacked bars or a combination of both.

20 [0013] In some examples, the controller may include multiple controls corresponding to the graphic symbols and coupled to the actuators, and engaging a first control articulates the elongate member in a direction of the first graphic symbol, engaging a second control bends the elongate member in a direction of the second graphic symbol, and engaging a third control bends the elongate member in a direction of the third graphic symbol. In some examples, engaging the first control and the second control simultaneously articulates the articulating portion of the flexible catheter in a direction between the first and second graphic symbols. In some examples, the controls and corresponding graphic symbols are color coded. In some examples, each of the graphic symbols is configured to change in size in proportion to an amount of articulation of the flexible catheter in a direction of the graphic symbols.

25 [0014] In various alternative, the virtual indicator may include at least one graphic symbol, such as but not limited to one or more arrows, stacked bars, ring-and-bead symbols, and/or ring-and-arrow symbols. In some examples, the controller includes a joystick. In some embodiments, the processor is configured to track the flexible catheter in the image using computer vision techniques. In such embodiments, the processor may be operable to overlay the virtual indicator on the image in response to tracking information.

30 [0015] An exemplary method for facilitating a robotic catheter procedure may involve generating, via a processor, a virtual indicator on a visual display, and overlaying the virtual indicator onto an image of at least an articulating portion of a flexible catheter used in the robotic catheter procedure on the visual display. The virtual indicator represents a direction of articulation and/or an amount of articulation of the articulating portion of the flexible catheter. In some examples, the method may further involve providing a user input device for receiving user inputs to control articulation of the articulating portion of the flexible catheter, where the user input device corresponds to the virtual indicator. Some examples may further involve manipulating the virtual indicator in response to a first user input, where the virtual indicator rotates about a longitudinal axis of the flexible catheter. Optionally, the method may also include articulating the flexible catheter in the direction of the virtual indicator, in response to a second user input.

35 [0016] In various alternative examples, the virtual indicator may include at least one graphic symbol, such as but not limited to an arrow, stacked bars, a ring-and-bead, and/or a ring-and-arrow. In some examples, the virtual indicator correlates to an actuator coupled to the flexible catheter. Some examples may also include engaging the actuator to articulate the articulating portion of the flexible catheter in the direction of articulation. Some examples may also include changing a size of the virtual indicator in response and in proportion to an amount of articulation of the articulating portion of the flexible catheter in the direction of articulation. Optionally, the method may also include tracking the flexible catheter in the image, using computer vision techniques, to generate tracking information, where the tracking information is used to overlay the virtual indicator on the image flexible catheter. The method may also optionally include registering the image of the flexible catheter with a fluoroscopic image of the flexible catheter to generate registration information, where the registration information is used to overlay the virtual indicator on the image.

40 [0017] These and other aspects and embodiments of the disclosure are described in greater detail below, in relation to the attached drawing figures.

55 BRIEF DESCRIPTION OF THE DRAWINGS

[0018] While the claims are not to be limited to the illustrated examples, an appreciation of various aspects is best gained through a discussion of various examples thereof. Referring now to the drawings, illustrative examples are shown

in detail. Although the drawings represent the exemplary illustrations, the drawings are not necessarily to scale and certain features may be exaggerated to better illustrate and explain an innovative aspect of a given example. Further, the exemplary approaches described herein are not intended to be exhaustive or otherwise limiting or restricting to the precise form and configuration shown in the drawings and disclosed in the following detailed description. Exemplary illustrations of the present invention are described in detail by referring to the drawings as follows:

5
10
15
20
25
30
35
40
45
50
55

FIG. 1A is a perspective view of a robotically controlled surgical system, according to one embodiment;
FIG. 1B is a magnified perspective view of a user interface having a controller and visual display of the robotically controlled surgical system of FIG. 1A;
FIG. 2 is a perspective view of an exemplary catheter assembly of the surgical system of FIG. 1A;
FIGS. 3 and 4 perspective views of components of the catheter assembly of FIG. 2;
FIG. 5 a perspective view of a distal end of an exemplary catheter that is controllable by internal control elements, according to one embodiment;
FIG. 6A is a top view of a controller with button controls, according to one example;
FIG. 6B is a perspective view of a catheter with a virtual indicator overlay, according to one example;
FIG. 6C is a top view of a controller with a joystick control, according to an alternative example;
FIG. 7A is a perspective view of an articulating distal portion of a catheter and top views of the controllers of FIGS. 6A and 6C, illustrating user input corresponding to the articulation of the distal portion, according to one example;
FIG. 7B is a perspective view of an articulating distal portion of a catheter and top views of the controllers of FIGS. 6A and 6C, illustrating user input corresponding to a different direction of articulation of the distal portion, according to one example;
FIG. 8A is a perspective view of a catheter with a virtual indicator overlay, according to one example;
FIG. 8B is a perspective view of a catheter with a virtual indicator overlay having a stacked bar configuration, according to an alternative example;
FIG. 8C is a perspective view of a catheter with a virtual indicator overlay having arrows with variable magnitude, according to another alternative example;
FIG. 9A is a perspective view of a distal portion of a catheter with a virtual indicator overlay having a ring-and-bead configuration, according to one example;
FIG. 9B is a perspective view of a catheter with a virtual indicator overlay having a ring-and-arrow configuration, according to an alternative example;
FIG. 10A a perspective view of a distal portion of a catheter arranged perpendicular to a plane of the visual display pointing into the visual display, and a side view of a joystick controller, illustrating its motion corresponding to the motion of the distal portion of the catheter, according to one example;
FIG. 10B a perspective view of a distal portion of a catheter arranged perpendicular to a plane of the visual display pointing out of the visual display, and a side view of a joystick controller, illustrating its motion corresponding to the motion of the distal portion of the catheter, according to one example;
FIGS. 11A and 11B are perspective and side views, respectively, of a controller of the user interface of FIG. 1B, according to one example;
FIG. 12 is a perspective view of a controller of the user interface of FIG. 1B, according to an alternative example;
FIG. 13 illustrates a distal portion of a catheter with a virtual dome constraining the motion of the catheter, according to one example;
FIGS. 14A and 14B illustrates the motion of the distal portion of the catheter enclosed by the virtual dome of FIG. 13;
FIGS. 15A and 15B are top views of a controller of the user interface of FIG. 1B, according to another alternative example;
FIG. 16 is a side view of a distal portion of a catheter, illustrating an effect of distal roll on a catheter with 180 degrees twist;
FIGS. 17A and 17B are end-on and perspective views, respectively, of a distal portion of a catheter, illustrating moments of movement on a catheter tip, according to one embodiment;
FIGS. 18A and 18B are end-on views of a distal portion of a catheter, illustrating roll compensation for no roll and 90 degrees roll, respectively, according to one embodiment;
FIGS. 19A and 19B are perspective and end-on views, respectively, of a magnetic encoder that uses a Hall-effect or magneto-resistive sensor to detect changes in polarity, according to one embodiment;
FIGS. 20A and 20B are exploded and assembled/side views, respectively, of a distal portion of a catheter including the magnetic encoder components of FIGS. 19A and 19B, according to one embodiment;
FIGS. 21A and 21B are end-on views of a magnetic ring of a magnetic encoder, illustrating asymmetrical weight of the ring, according to one embodiment;
FIG. 22A is a perspective view of a distal portion of a catheter with a distal tip camera, according to one embodiment;
FIG. 22B is a front view of two video displays illustrating image representations of the catheter of FIG. 22A, illustrating

what a user would see on the screen when the catheter is equipped with a camera for zero degrees roll; FIG. 23A is a perspective view of a distal portion of a catheter with a distal tip camera, according to one embodiment; FIG. 23B is a front view of two video displays illustrating image representations of the catheter of FIG. 23A, illustrating what a user would see on the screen when the catheter is equipped with a camera for 90 degrees roll; FIGS. 24A and 24B are perspective diagrammatic representations of a distal end of a catheter, illustrating roll compensation for no camera roll and 90 degrees camera roll, respectively, according to one embodiment; and FIGS. 25A and 25B are perspective and end-on views of a catheter system, illustrating a simulated usage of a camera and a guide catheter.

DETAILED DESCRIPTION

[0019] Referring now to the drawings, illustrative embodiments are shown in detail. Although the drawings represent the embodiments, the drawings are not necessarily drawn to scale, and certain features may be exaggerated to better illustrate and explain innovative aspects of an embodiment. Further, the embodiments described herein are not intended to be exhaustive or otherwise limit or restrict the invention to the precise form and configuration shown in the drawings and disclosed in the following detailed description.

[0020] The disclosure describes systems and devices for improving instinctive driving of an elongate member, for example a flexible catheter. As described herein, a user interface may be configured to take advantage of catheter orientation information, such as roll and/or articulation, to provide a more intuitive controller to navigate the tortuosity of the vasculature. That is, the user interface may use information acquired from sensors, such as electro-magnetic sensors embedded into the catheter, and/or fiber optic sensors that may run the length of the catheter (e.g., FOSSL), for virtual representation of the position and orientation of the catheter within the patient's anatomy. In some embodiments, sensors may be used to determine and control catheter roll or twist to facilitate instinctive manipulation of a catheter as it is navigated through a patient's anatomy. A user interface may also use information acquired from the imaging system (e.g., such as fluoroscopy) via computer vision techniques. The disclosed user interface and roll control may take advantage of the received information to provide more intuitive commands to facilitate navigation through the patient's anatomy.

[0021] Referring now to FIG. 1A, a robotically controlled surgical system 100 may include a robotic catheter assembly 102 having a robotic or first or outer steerable component, otherwise referred to as a sheath instrument 104 (generally referred to as "sheath" or "sheath instrument") and/or a second or inner steerable component, otherwise referred to as a robotic catheter or guide or catheter instrument 106 (generally referred to as "catheter" or "catheter instrument"). Catheter assembly 102 is controllable using a robotic instrument driver 108 (generally referred to as "instrument driver"). During use, a patient is positioned on an operating table or surgical bed 110 (generally referred to as "operating table") to which robotic instrument driver 108 is coupled or mounted via a setup mount 112. Setup mount 112 may likewise include a rail system (not shown) configured to allow the setup mount 112 to translate along the length of surgical bed 110, and a motorized rail, (e.g., rail shark fin illustrated as the triangular plate) configured to tilt the instrument driver 108. As shown in FIG. 1A, system 100 includes an operator workstation 114, an electronics rack 116, a guide wire manipulator 118, and an associated bedside electronics box 120, and instrument driver 108. A surgeon is seated at operator workstation 114 and can monitor the surgical procedure, patient vitals, and control one or more catheter devices.

[0022] System components may be coupled together via multiple cables or other suitable connectors 118 to provide for data communication, or one or more components may be equipped with wireless communication components to reduce or eliminate cables 118. Communication between components may also be implemented over a network or over the Internet. In this manner, a surgeon or other operator may control a surgical instrument while being located away from or remotely from radiation sources, thereby decreasing radiation exposure. Because of the option for wireless or networked operation, the surgeon may even be located remotely from the patient in a different room or building.

[0023] The workstation 114 may include a user interface 124 configured to receive user inputs to operate various components or systems of the surgical system 100. The user interface 124 may include a controller 126 to enable the operator to control or manipulate the robotic catheter assembly 102. For instance, the controller 126 may be configured to cause the catheter to perform various tasks and/or movements (e.g., insert, retract, rotate, articulate, etc.). The controller 126 may be operable to allow the operator to navigate the catheter through the patient's anatomy via articulating the distal tip of the steerable catheter.

[0024] In some embodiments, the controller 126 may include a planar input (e.g., a joystick) and surrounding dedicated buttons configured to insert, retract, rotate, and articulate the guide wire and/or catheter, as discussed below. Additionally or alternatively, the controller 126 may include a touch screen configured to display icons corresponding to catheter and/or guide wire movements (e.g., insert, retract, roll, articulate, inflate/deflate a balloon or stent, etc.). Thus, the controller 126 may include one or more buttons, joysticks, touch screens, or other user input devices that may be desirable to control the particular component to which the controller is dedicated.

[0025] The user interface 124 may include a visual display or screen 128 configured to display information or patient-

specific data to the operator located at the workstation 114. In one embodiment, the visual display 128 may be configured to display patient image data (e.g., x-ray images, MRI images, CT images, ultrasound images), physiological statistics (e.g., blood pressure, heart rate, respiratory rate), and/or patient medical records (e.g., medical history, weight, age). The visual display 128 may likewise be configured to display an image of a portion of the patient at one or more magnification levels. Additionally, the visual display 128 may be configured to receive transmissions indicating catheter position and orientation information for display. For example, the visual display 128 may be configured to display information regarding the position and/or articulation of the distal tip of a steerable catheter. Alternatively or additionally, the user interface 124 may include one or more hazard indicators (e.g., graphics, color-coding, light displays) to indicate a condition of the catheter or the system. For example, if the difference between the magnitude of commanded articulation and magnitude of measured articulation of the catheter increases beyond a threshold level, the catheter may be obstructed, for example in the vasculature, and the user may be alerted to the hazard condition of the catheter. Furthermore, the visual display 128 may be configured to display information to provide the functionalities associated with various controls of the controller 126, as discussed below. The visual display 128 may comprise one video screen, or may comprise multiple video screens working in conjunction with one another.

[0026] FIG. 1B illustrates the workstation 114 and user interface 124 in greater detail. The user interface 124 may receive an operator input and be configured to command movement of a flexible catheter or other flexible elongate member. The user interface 114 may include the physical controller 126, with which the operator interacts, and at least one visual display 128 configured to depict an image of the elongate member, human anatomy, patient vitals, virtual indicators, etc. For example, a fluoroscopic, CT image, MRI image, or other suitable image may be displayed on the visual display 128, with a virtual overlay indicating catheter orientation, movement, and/or direction. The controller 126 may be configured to manipulate the virtual representation of the catheter on the visual display 128, which correspondingly manipulates related components of the physical catheter. That is, manipulating the controller 126 directly corresponds to manipulating the actual catheter. The workstation 114 may be located within the procedure room, or may be located remotely (e.g., in a control room, physician's office). The controller 126 may include dedicated controls configured to actuate movement of the elongate member. For example, the controller 126 may be configured to cause the catheter assembly 102 to perform various tasks and/or movements. According to another example, the controller 126 may be configured to manipulate the virtual catheter representation on the visual display 128 without likewise manipulating the physical catheter, for example in a predictive user interface, as will be discussed in detail below.

[0027] Referring now to FIG. 2, an instrument assembly 200 for driving and/or manipulating an elongate member includes sheath instrument 104 and the associated guide or catheter instrument 106 mounted to mounting plates 202, 204 on a top portion of instrument driver 108. During use, the elongate catheter portion of catheter instrument 106 is inserted within a central lumen of the elongate sheath portion of sheath instrument 104 such that instruments 104, 106 are arranged in a coaxial manner. Although instruments 104, 106 are arranged coaxially, movement of each instrument 104, 106 can be controlled and manipulated independently. For this purpose, motors within instrument driver 108 are controlled such that carriages coupled to mounting plates 204, 206 are driven forwards and backwards on bearings. As a result, a catheter coupled to guide catheter instrument 106 and sheath instrument 104 can be controllably manipulated while inserted into the patient, as will be further illustrated. Additional instrument driver motors may be activated to control articulation of the catheter as well as the orientation of the distal tips thereof, including tools mounted at the distal tip. Sheath catheter instrument 106 is configured to move forward and backward for effecting an axial motion of the catheter, for example to insert and retract the catheter from a patient, respectively.

[0028] Referring to FIG. 3, an assembly 300 includes sheath instrument 104 and guide or catheter instrument 106 positioned over their respective mounting plates 206, 204. In some embodiments, a guide catheter instrument member 302 is coaxially interfaced with a sheath catheter member 304 by inserting the guide catheter instrument member 302 into a working lumen of sheath catheter member 304. Sheath catheter member 304 includes a distal end that is manipulatable via assembly 300, as will be further discussed in FIG. 5. Sheath instrument 104 and guide or catheter instrument 106 are coaxially disposed for mounting onto instrument driver 108. However, in some embodiments, a sheath instrument 108 may be used without guide or catheter instrument 106, or guide or catheter instrument 106 may be used without sheath instrument 104 and may be mounted onto instrument driver 108 individually.

[0029] Referring to FIG. 4, when a catheter is prepared for use with an instrument driver, its splayer is mounted onto its appropriate interface plate. In this case, sheath splayer 308 is placed onto sheath interface plate 206 and a guide splayer 306 is placed onto guide interface plate 204. In the illustrated example, each interface plate 204, 206 has respectively four openings 310, 312 that are designed to receive corresponding drive shafts 314, 316. FIG. 4 illustrates an underside perspective view of shafts 314, 316 attached to and extending from the pulley assemblies of the splayers 308, 306.

[0030] Further, as shown in FIGS. 3-5, a sheath instrument 104 may include a sheath splayer 308 having drive shafts 314. Catheter instrument 106 may include a guide splayer 306 having drive shafts 316. Drive shafts 316 are each coupled to a respective motor within instrument driver 108 (motors not shown). When 4-wire catheter 304 is coupled to instrument driver 108, each drive shaft 316 thereof is thereby coupled to a respective wire 504-510, as shown in FIG. 5. As such,

a distal end 502 of catheter 304 can be articulated and steered by selectively tightening and loosening wires 504-510. Typically, the amount of loosening and tightening is slight, relative to the overall length of catheter 304. For example, each wire 504-510 typically need not be tightened or loosened more than perhaps a few centimeters.

5 [0031] Referring to FIG. 5, the operator workstation 114 may include a computer monitor to display a three dimensional object, such as an image 512 of a catheter instrument 304. Catheter instrument 304 may be displayed within or relative to a three-dimensional space, such as a body cavity or organ, for example a chamber of a patient's heart or a femoral artery of a patient. In one embodiment, an operator uses a computer mouse to move a control point around the display to control the position of catheter instrument 304.

10 User Interface for Instinctive Catheter Control

[0032] Referring to FIGS. 6A-6C, in one example, a controller 400 (FIG. 6A) for manipulating/articulating a catheter 412 (FIG. 6B) may include a first control 406, a second control 408, and a third control 410. Each control 406, 408, 410 may include a visual identifier, such as alphabetical letters A, B, and C, colors such as red, green, and blue, and/or the like, for convenience of the operator. Referring to FIG. 6B, visual display 404 may depict an elongate member, such as a distal portion of a catheter 412 (or "catheter tip"). In this example, the visual display shows the distal portion of the catheter 412, with three pull wires 422, 424, 425 and a virtual indicator overlay displaying on the catheter 412. In this example, the virtual indicator overlay includes three virtual indicators 414, 416, and 418 (or "graphic symbols"), which are arrows in the example shown but may be stacked bars or other direction indicators in other embodiments. Each of the virtual indicators 414, 416, and 418 corresponds to one of the controls 406, 408, 410 and one of the pull wires 422, 424, 425. In some examples, the image of the catheter 412 may be an image acquired via any suitable medical imaging technique, such as but not limited to fluoroscopy, magnetic resonance imaging (MRI), ultrasonography, computed tomography (CT), or the like. Alternatively, the image of the catheter 412 may be a computer generated image.

20 [0033] The virtual indicators 414, 416, 418 are computer-generated images overlaid onto the image of the catheter 412 to illustrate a commanded movement of the catheter 412, a measured movement of the catheter 412, a difference between the two, or some combination thereof. Again, each of the virtual indicators 414, 416, 418 corresponds to one of the controls 406, 408, 410 and also one of three pull wires 422, 424, and 426 configured to manipulate and/or steer the catheter 412. In some emb examples, the virtual indicators 414, 416, 418 and the controls 406, 408, 410 may be color coded to match one another. Each control actuation, for example pressing the green button, will result in a tensioning a wire that articulates the catheter in a corresponding direction-e.g., the green arrow direction in this example. In some examples, fewer or greater amounts of buttons and/or wires may be used. For example, a catheter may include 0 to 5 wires or 5 to 10 wires, or any subrange between those ranges. In one embodiment, a catheter includes 4 wires. In some examples, a controller may include 0 to 5 or 5 to 10 buttons or controls or any subrange between those ranges. In one embodiment, a controller includes 4 buttons or controls. In some embodiments, the button-to-wire ratio remains fixed throughout the procedure (e.g., 1:1 button to wire relationship).

30 [0034] As mentioned above, in various examples, the visual display 404 and virtual indicators 414, 416, 418 may show a commanded movement of the catheter 412, a measured movement of the catheter 412, a difference between the two, or some combination thereof. "Commanded movement" or "commanded value" is intended to mean the direction (and in some embodiments the amount) of catheter movement directed by a user via the controls 406, 408, 410. "Measured movement" or "measured value" is intended to mean the direction (and in some embodiments the amount) of catheter movement measured by the system 100, for example via a sensor (or multiple sensors) on the catheter. In some examples, for example, the visual display 404 may show a user the direction in which the catheter 412 has been commanded to articulate, an amount of commanded articulation in the commanded direction, and also a direction and amount of actual, measured articulation of the catheter. This type of information allows the user to see how the instructed/commanded movements have translated into actual/measured movements. As discussed further below in terms of several alternative embodiments, the visual display 404 may provide this information using any of a number of different types of visual indicators 414, 416, 418, such as arrows of different sizes and shapes, stacked bars having sizes and numbers corresponding to amounts of commanded articulation of a catheter, and the like. The overlay of indicators onto an image of a catheter to provide information about catheter movement to a user may be very advantageous in providing an intuitive catheter driving experience for the user.

40 [0035] In some examples, the visual display 404 of the user interface may be configured to display information near the tip of the depicted catheter 412 so that the information stays within the operator's field of vision at all times of the procedure, unless turned off explicitly. As such, a virtual representation may overlay an imaged catheter 412 on the visual display 404 (e.g., a viewing screen), which includes virtual indicators 414, 416, 418 corresponding to visual identifiers disposed on the controls 406, 408, and 410. The visual display 404 may illustrate which direction the catheter will articulate in response to actuating a control corresponding to the virtual indicator. For example, the green arrow may indicate the catheter will move radially in the depicted direction with respect to an axis in a plane of the visual display 404.

50 [0036] In some examples, a processor (not shown) may be configured for generating the virtual representation of the

catheter 412 using kinematic, FOSSL, electro-magnetic information, or imaging information acquired by computer vision techniques, for example, regarding the catheter. The processor may be configured to superimpose the virtual indicators 414, 416, 418 over the tip of the catheter 412. For instance, virtual indicators 414, 416, 418 may overlay a fluoroscopic or like image of the catheter 412 inserted in the patient's anatomy, such that the visual display 404 shows the fluoroscopic image with the virtual indicator overlay to improve instinctive navigation of the catheter. Further, the processor may be configured to adjust the virtual indicators 414, 416, 418 with corresponding movements of the catheter, such that the indicators 414, 416, 418 overlay the catheter 412 in proper position/orientation as the catheter 412 moves within the patient's anatomy. For example, if the catheter 412 rolls or twists during navigation, the virtual indicators 414, 416, 418 may adjust accordingly, such that the user always knows which wire to manipulate to drive the catheter 412 to the desired location in the vasculature. In some examples, a non-transitory medium (not shown), storing a set of instructions may be configured to superimpose the virtual indicators 414, 416, 418 over a fluoroscopic image of the catheter 412. The instructions may additionally be operable to allow an operator to manipulate the catheter 412 via input from the controller 400. In some examples, the instructions may be updated periodically to account for changes in catheter orientation and/or position, for example if the catheter 412 rolls or twists during navigation.

[0037] In some examples, as shown in FIG. 6A, the controller 400 may include a planar input device, such as control buttons 406, 408, 410, as described above. The button-to-wire relationship may be fixed throughout the entire procedure, such that a particular button press may always cause a particular wire to be pulled-for example, pressing the green button will always pull the green wire, regardless of catheter orientation on the visual display 404. Further, in some examples, the controller 400 may include three button controls 406, 408, and 410, corresponding to the three pull wires 422, 424, 425 in the catheter 412, for example as represented by the three virtual indicators 414, 416, and 418 as shown in FIG. 6B. Pressing the control button 408 correspondingly actuates the pull wire 424 associated with virtual indicator 416. As shown in FIG. 6A, the controller 400 may optionally include a fourth control 420 configured to release or relax the pull wires 422, 424, 425 and thereby relax the catheter 412 to a straight position. In one alternative embodiment (not shown), each control button may include two separate buttons, in which the inner button would release the pull wire associated with the controller and hence relax the catheter (e.g., relaxing red button would relax the red wire). The outer button would pull or tension the wire to articulate the catheter in the direction of the virtual indicator.

[0038] The control buttons 406, 408, 410, and/or 420 may be touch sensitive, such that the harder a button is pushed or the more force exerted on the button, the more the button will actuate, pull, or tension the corresponding pull wire 422, 424, 425. Thus, a button pushed fully to the base of the controller 400 may pull the corresponding wire to the maximum, so that the catheter 412 is articulated maximally in the direction of the pulled wire 422, 424, 425.

[0039] Further, the control buttons 406, 408, 410 may be combined or actuated simultaneously to articulate the catheter 412 in a direction that lies in between two pull wires 422, 424, 425. For example, still referring to FIG. 6A, if control buttons 406 and 408 are pushed together, the system would pull wires 422 and 424, associated with indicators 414 and 416, thereby making the catheter 412 articulate in a direction between pull wires 422 and 424.

[0040] Referring now to FIG. 6C, in some examples, a controller 426 may include a control column or joystick 428 operable to gradually move about the base of the controller 426. In some examples, the controller 426 may include the joystick 428 and visual identifiers 430, 432, 434 on the controller 426 base, which indicate direction and/or corresponding virtual indicators and pull wires 422, 424, 425. For example, the graphics may relate to the virtual indicators 414, 416, 418 on the visual display 404 as well as the pull wires 422, 424, 425 running through the catheter 412 to perform movements. Further, as an analog device, the joystick 428 can move gradually between adjacent buttons to mimic either single or simultaneous control button input, and the articulation direction of the catheter would thereby vary smoothly between wires. The joystick 428 may be arranged concentrically with respect to the pie-shaped graphic drawing (e.g., analogous to the three button controller 400). The graphics 430, 432, and 434 suggest which pull wire 422, 424, 425 will be pulled if the joystick 428 is moved in a particular direction.

[0041] In one examples, the joystick 428 may include a return, for example a spring. Alternatively, the joystick 428 may not be loaded with a return, which means the joystick 428 will not return to the center when external force is removed. For example, the joystick 428 may be a position control device that maintains its tilt or orientation when released or external force on the joystick is removed. In some examples, the joystick 428 in a straight up, vertical, or perpendicular position relative to the controls may be equivalent to the catheter being fully relaxed, while the full forward position of the joystick (e.g., in relation to FIG. 6C, fully forward on graphic 430) means the wire associated with 430 is pulled or tensioned to the maximum, so that the catheter 412 is articulated maximally in the 430 direction. Stated alternatively, if red is the indicator associated with 430, pushing or manipulating the joystick 428 fully towards red will pull or tension the red wire 422 maximally, so the catheter 412 is articulated maximally in the red direction, as indicated by a red virtual marker 414 on the visual display 404. Advantageously, a controller 426 with a joystick 428 enables the operator to easily determine how much effort was required for tensioning each wire 422, 424, 425, by observing the orientation or position of the joystick 428. Further, the joystick 428 indicates the degree of effort the controller 426 attempts to effectuate catheter articulation. For example, if the joystick 428 is only slightly offset from center, then minimal effort may be exerted in pulling or tensioning the wire. Alternatively, if the joystick 428 is fully actuated, then full force may be exerted on the wire

and the catheter 412 is maximally articulated, e.g., in the current environment. However, while the controller may exert maximum effort in attempting to articulate the catheter 412, the catheter 412 itself may not articulate, if there is an obstruction from the human anatomy and/or if the catheter 412 is experiencing roll or twist, for example.

5 [0042] FIGS. 7A and 7B illustrate equivalent button and joystick control inputs that would cause a catheter 612 to articulate toward a red wire 622 (Fig. 7A) and in between the red wire 622 and a blue wire 624 (Fig. 7B). For example, FIG. 7A shows a catheter 612 responding to a single control button push or joystick movement in the direction of red 606 and consequently pulling or tensioning the red wire 622 represented by the red indicator 614, thereby articulating the catheter 612 in the direction of the large arrow 620. Alternatively, FIG. 7B illustrates the catheter 612 responding to a simultaneous red and blue button 606, 610 press or the joystick moving in between the red and blue 606, 610 graphics. Simultaneously actuating controls 606 and 610 will trigger corresponding wires 622 and 624 (e.g., represented by virtual indicators 616, 618) to pull or tension, resulting in articulation of the catheter 612 in the direction of the large arrow 620. While some examples may have a separate color button for each wire on the catheter 612, an alternative embodiment may involve a bend button and a rotate button with colors of the wires identified on the rotate button. In this example, the user would use the rotate button to orient with the required color and then press the bend button to bend in the required direction. This has the advantage of not requiring a bend button for each wire on the circumference of the catheter.

10 [0043] Referring now to FIGS. 8A-8C, alternative examples of a visual display 700, 720, 730 may be used to illustrate movement of a catheter 702, for example to enhance instinctive navigation of the catheter 702. In the embodiment of FIG. 8A, the visual display 700, virtual indicators 704, 706, 708 are superimposed on a fluoroscopic image of the catheter 702. In order to easily identify which wire is controlled by which control (e.g., buttons or action of the joystick), identifiers for each wire are displayed near or superimposed onto the tip of the catheter. In one example, a red indicator 704, a green indicator 706, and a blue indicator 708 are overlaid or superimposed onto three control wires 710, 712, and 714, respectively. The virtual overlay indicators 704, 706, 708 likewise match the colors of the controls discussed above, indicating their one-to-one relationship (e.g., the control-to-wire relationship is fixed throughout the procedure, such that a particular control will always cause a particular wire to be pulled). Further, the indicators 704, 706, 708 are intuitive and easily distinguishable, so that the operator may immediately recognize the indicator 704, 706, 708 (and consequently the corresponding pull wire) upon glancing at it.

15 [0044] In some examples, a view of the catheter may change during a procedure or use case. In some embodiments, a catheter orientation or position may be indicated in a first or second view of the catheter using one or more methods, for example shading or coloring of the catheter based on the depth of the catheter into the viewing plane away from the user or 3-D viewing technology that may be manipulated (e.g., rotated, magnified) to view the catheter from one or more directions. In some such examples, the virtual indicator may automatically change and update based on the current view. For example, if the controls are labeled "green" for left and "blue" for right in a first view, the virtual indicators may be exchanged such that "green" still means left and "blue" still means right in a second view, for example if the catheter has rolled or twisted in the second view.

20 [0045] In some examples, the first view may be instinctive while the second view is not instinctive. In some such embodiments, a focus, gaze, or attention of a user may be tracked, for example by a camera, to determine which view the user is using, such that the instinctiveness of the view relies on whether the user is using that particular view. Alternatively, the system may force the user to use, for example, only the first view as their primary view by either changing the size of the view or changing the on-screen indicators, such that first view is the instinctive view.

25 [0046] Furthermore, in addition to being color coordinated, the overlay virtual indicators 704, 706, and 708 may be extended or enlarged to demonstrate the load on the wire (e.g., an amount or duration of force placed on the wire), which may serve as an important metric in determining whether the patient's anatomy is restricting movement. For example, the operator may compare the control effort (e.g., the magnitude of the virtual indicator) with the actual articulation amount of the catheter to determine if a patient's anatomy is restricting the movement of the catheter.

30 [0047] FIG. 8B illustrates another example, in which a visual display 720, uses stacked bar indicators 724, 726, 728, with variable magnitude representing differing wire loads. FIG. 8C illustrates another example of a visual display 730, in which arrow indicators 724, 736, 738 have differing magnitudes representing differing wire loads. Either or both of the examples illustrated in FIGS. 8B and 8C may also be used with the example of the visual display 700 illustrated in FIG. 8A. A bar or arrow with greater magnitude represents the load on the wire, which is correspondingly greater. Accordingly, the operator may thereby minimize unwanted damage to vessel walls by observing the changing magnitude of the virtual indicator and comparing the actual movement of the catheter. If the magnitude is great and the movement is minimal, the operator may conclude that the catheter is being restricted by the patient's anatomy. Additionally or alternatively, the user interface may be configured to provide a tactile feedback indicating that the catheter is being restricted by the patient's anatomy (e.g., the joystick vibrates upon being obstructed).

55 Predictive User Interface for Instinctive Catheter Control

[0048] In some examples, the user interface 124 may be configured to receive an operator input and command the

movement of a virtual representation, e.g., a virtual indicator, overlaying an image of a flexible catheter, for example generated by a processor. In some examples, the virtual indicator does not represent the current articulation direction of the elongate member, but rather indicates which movement the catheter would make, if the motors/drivers were engaged, e.g., a predictive virtual representation. The predictive virtual indicator may overlay or otherwise be superimposed over an actual image of the catheter (e.g., via medical imaging such as fluoroscopy, thermography, magnetic imaging, ultrasonography, computed tomography, positron emission tomography, etc.). The virtual indicator may be aided in tracking the catheter in the image using computer vision techniques to process the image and determine the catheter location.

[0049] Referring now to FIGS. 9A and 9B, two alternative examples of virtual indicator overlays 802, 822 on images 800, 820 of a distal portion of a catheter 808 are illustrated. In the example shown in FIG. 9A, the virtual indicator overlay 802 is a graphic symbol including a bead 804 on a ring 806. The position of the bead 804 along the ring 806 indicates a bend direction of the catheter 808, and the bead 804 may move around the circumference of the ring 806, as indicated by the double-pointed arrow. In another example, as illustrated in FIG. 9B, the image 820 may include a virtual indicator overlay 822 that includes a ring 826 and an arrow 824. The arrow 824 may indicate bend directionality in a way that is similar to that of the bead 804 and may similarly move around the circumference of the ring 826. In some examples, the arrow 824 may also grow and/or shrink in size to indicate the amount of commanded bending signal (e.g., the amount of bend commanded by the user via a user input). As shown in FIGS. 9A and 9B, the bead 804 or arrow 824 virtual indicator represents the direction the catheter 808 would articulate if the controller were engaged. Stated alternatively, the predictive virtual indicator 802, 822 uses available elongate member or catheter roll information to notify the operator of the imminent articulation direction before the elongate member 808 is articulated.

[0050] Importantly, the predictive virtual indicator overlay 802, 822 may instruct the operator whether the catheter 808 is pointing into or out of the screen when the elongate member 808 is positioned in a plane perpendicular to the visual display 128. It can be very difficult to decipher whether the elongate member 808 is pointing into or out of the visual display 128. In some examples, the direction in which the ring or arrow virtual indicator 822 rolls in relation to direction of the controller input may determine whether the elongate member 808 is pointing into or out of the screen in a plane perpendicular to the visual display 128.

[0051] For example, as shown in FIGS. 10A and 10B, the bead 804 (or arrow 824 in an alternative embodiment) on the predictive indicator 802 may roll in the opposite direction of the controller input if the elongate member 808 is pointed out of the visual display 128 (e.g., the elongate member 808 is facing towards the operator). For example, FIG. 10A illustrates the elongate member 808 pointing into the visual display when the predictive virtual indicator 804 rolls in the same direction as that of a joystick 838 (e.g., both roll clockwise). Alternatively, FIG. 10B illustrates the elongate member 808 pointing out of the visual display, because the predictive virtual indicator 804 rolls in a direction opposite of the joystick 838 (e.g., controller rolls clockwise and the predictive indicator rolls counterclockwise). Accordingly, the operator can easily decipher the heading of the elongate member 808 without actually articulating the elongate member 808 and thus potentially harming the patient's vasculature.

[0052] In some examples, the visual display 128 (Figs. 1A and 1B) may be in communication with a processor (not shown). The processor may generate the virtual indicator 802 overlaid on an actual image of a catheter 808 inserted into the patient's anatomy. The processor may be configured to adjust or manipulate the virtual indicator 802 to indicate which direction the catheter 808 would articulate if the controller were engaged. Further, the processor may be operable to dynamically determine the desired articulation direction of the catheter (e.g., which wire(s) to pull/tension and which wire(s) to relax) based on the bead/arrow position on the virtual indicator 802. A non-transitory medium (not shown) storing a set of instructions may include one or more instructions to superimpose the virtual indicator 802 on the tip of the catheter 808 and one or more instructions for allowing the operator to rotate the virtual indicator 802 circumferentially around an axis. Additionally, the set of instructions may further include one or more instructions for allowing the user to manipulate multiple controls to move the catheter/elongate member 808, and may include a set of instructions for using kinematic information or sensor data (e.g., FOSSL, electromagnets), for example, to orient, position, and coordinate the virtual indicator 802 with the catheter 808. The virtual indicator 802, therefore, advantageously uses available catheter 808 roll information to notify the operator of the imminent articulation direction before the catheter 808 actually articulates. Accordingly, the operator is encouraged or expected to interact with the virtual indicator 802 and visual display 128 to fine-tune the orientation of the virtual bead or arrow.

[0053] Once the catheter 808 is actually articulated, the virtual indicator 802 will show the actual movement of the catheter 808. Thus, the indicator 802 not only shows the user how the catheter 808 will (or should) articulate before actual articulation, but it also shows the user how the catheter 808 actually articulates.

[0054] Referring now to FIGS. 11A and 11B, in some examples, the controller 844 may include multiple controls, such as a first control 842 configured to roll/rotate the predictive indicator 606, a second control 846 configured to articulate the elongate member 608, and a third control 848 configured to relax the elongate member 608. As shown in FIGS. 11A and 11B, the first control 842 may include a control column or joystick. Alternatively, in some examples, the first control 842 may be a touch sensitive pad. The first control or joystick 842 may be configured to rotate or roll while in the upright

or vertical position which correspondingly controls the rotation of the bead or arrow on the ring of the virtual indicator. In some embodiments, the joystick 842 is a position controller and rotating the joystick 842 in the clockwise direction would roll the bead/arrow of the virtual indicator in the same direction (unless, however, if the elongate member is pointing out of the screen, in which case the bead/arrow would roll opposite the direction of the rotation of the joystick 842). It should be noted that in some examples, the catheter is not actually "rotated" or "rolled" in response to a command to "rotate" or "roll," but is progressively articulated using pull wires to mimic a rotational movement. For example, if a command is provided to articulate the catheter to the right, the system pulls or tensions a wire to articulate the catheter to the right. Subsequently, if the bead/arrow is rotated 180 degrees and the same articulation button is depressed, the system understands that the bead/arrow has been rotated, and in response pulls or tensions another wire to articulate the catheter to the left. In short, the system may dynamically decide which wire to pull/tension and relax based on the bead/arrow location on the virtual indicator. Further, in this example, the catheter does not physically roll/rotate, but rather the virtual indicator rotates in the visual display. As mentioned, the system 100 is configured to determine the articulation direction (and consequently the respective wire(s) to actuate and relax) in response to the position of the bead/arrow on the virtual indicator. Therefore, the system 100 reduces operator error and minimizes inadvertent touching of vessel walls.

[0055] The joystick 842 may likewise be configured to tilt forward and backward to command the elongate member to insert or retract, respectively. That is, the joystick 842 is a rocker switch but with added granularity allowing finer motion control. The joystick 842 may be spring loaded so that the joystick 842 returns to its upright/vertical, middle position when no external force is applied. The control input (e.g., tilting for insert/retract and/or the rate of return back to the middle position) may be mapped to the rate of increase or decrease as in velocity control. For example, tilting the joystick 842 fully forwards or backwards may insert/retract the elongate member at a greater velocity than slightly tilting the joystick. The rate at which the joystick 842 returns without external force, however, may be a constant velocity.

[0056] In some examples, the controller 844 may likewise include multiple push controls, for example a second control 846 and a third control 848. For example, the second control 846 may be configured to articulate the elongate member, while the third control 848 may be configured to relax the elongate member (e.g., an articulation button and a relax button). For example, once the direction is set in which the elongate member would articulate via the joystick 842 (e.g., rotating the bead/arrow), pressing the second control 846 button will physically articulate the elongate member in the set direction. The elongate member may continue to articulate until the force is lifted from the first control 842 (e.g., until the operator releases the articulate button). Further, pressing and holding the third control 848 will gradually relax the elongate member back to its straight configuration. Thus, the elongate member may remain in its articulated configuration until the third control 848 is pressed to relax the elongate member.

[0057] Referring now to FIG. 12, an alternative example of a controller 904 may include a joystick 910, a bend button 912, a relax button 914, a roller 916 and a light feature 918. The roller 916 (or "fourth control") may act as a locking feature (or alternatively another form of failsafe mechanism in alternative examples), to ensure there is no accidental activation of roll or insertion activities. The roller 916 may be operable to rotate and correspondingly rotate the bead/arrow virtual indicator. Thus, the joystick 910 may be configured to move forward and backward for insertion and retraction, respectively. Alternatively, the joystick 910 may be configured as a toggle button, in which the entire joystick 910 can be pushed down from the top to either activate or deactivate the locking feature. With the roll lock enabled, the roller 916 may still be operable to rotate but without having any effect on the virtual indicator, and hence no change in articulation direction. However, even with the locking feature, the roller 916 may still be used for combining the insertion and roll of the elongate member (e.g., simultaneous actions) by merely disabling/deactivating the lock feature. The controller 904 base may also include the light feature 918 or other indicator, for example a circular area around the base of the controller 904 embedded with different colors to indicate whether the lock has been enabled.

[0058] Referring now to FIG. 13 illustrates an image of a dome 920 at a distal end of the elongate member 908. The dome 920 may represent a constraint for the catheter 908 tip so that at least part of the catheter 908 tip is required to be on a surface of the dome 920 regardless of how the catheter 908 is driven. In one embodiment, the catheter tip motion is confined to a surface of the virtual dome 920 created around a base 922 of its articulation section 924, and a 3D joystick (not shown), for example, would navigate the catheter tip around the dome's surface. According to one example, the circumference of the dome 920 may expand depending on the exposed length of the catheter's articulation section (e.g., a telescoping catheter). Alternatively, the full length of the articulation section may be used to set the size of the dome 920.

[0059] A virtual ring 926 may be a projection of the catheter tip onto the dome 920 surface and the bead/arrow 928 indicates which direction the ring would move if the controller were engaged. Accordingly, the virtual indicator 906 is always on the dome 920 surface. Pressing the articulation button as described above would move the catheter 908 tip in the direction towards the bead/arrow 928 along the dome 920 surface.

[0060] For example, FIG. 14A illustrates a response of the catheter 1008 when the virtual indicator 1006 is rolled ninety (90) degrees in clockwise direction prior to the user pressing the articulation button. (The direction of rotation, in this example, is from the perspective of inside of the catheter 1008. An observer outside the catheter 1008 would view

this rotation as appearing counter clockwise.) When the articulation button is pressed, the ring 1026 moves along the surface of the dome 1020 following the direction of the bead 1028. If the virtual indicator 1006 is rolled forty five (45) degrees more, pressing the articulation button would initially roll and relax the catheter 1008 at the same time, but the catheter 1008 would eventually articulate away from the user, for example as shown in FIG. 14B. This can be seen in FIG. 14B, illustrating the successive roll/relax and roll/articulate events. For example, the catheter 1008 relaxes as the tip or ring 1026 straightens and moves towards the top of the dome 1020, but the articulating angle subsequently increases as the ring 1026 moves further way from the dome 1020 apex. Thus, the relax control button may be redundant as the operator can always roll the indicator 1006 a hundred and eighty (180) degrees and press the articulation button to relax the catheter 1008. However, the separate control button may make it easier to access this important function, as pressing relax would always bring the catheter 1008 tip back to the top of the dome 1020 following the shortest path regardless of roll and articulation.

[0061] The virtual dome implementation may use the same physical controller as illustrated in FIG. 11A, 11B, or 12 (e.g., a 3D joystick with articulate/relax control buttons). Alternatively, FIG. 15A illustrates a controller 1100 according to another example. The controller 1100 may have a roll knob 1102, four control buttons for articulating 1104, relaxing 1106, inserting 1108, and retracting 1110. The controller 1100 illustrated in FIG. 15B is similar in that the roll knob 1102 is the same, but the right and left buttons would be disabled such that the up/down buttons may be used for articulating and relaxing, respectively. A switch or slider 1112 may be operable to move back and forth for inserting and retracting.

Roll Compensation for Instinctive Catheter Control

[0062] Previously, a catheter was presumed to not rotate or roll around its axis as it advances through the vasculature. However, this presumption is not true in reality. For example, as shown in FIG. 16, a distal section of a catheter 808 is illustrated with a 180 degree twist. When the controller desires to articulate the catheter to the right, it pulls the wire on the right side of the catheter 808. However, instead of articulating to the right, the catheter 808 may articulate to the left because of the roll or twist experienced by the catheter 808. Previously, the controller could not make proper adjustments to correct the action because there was no concept of catheter roll. However, as will be described in further detail below, a roll sensor may be used to enable roll compensation and correction.

[0063] A roll sensor has the potential to improve the catheter driving experience by enabling the controller adapt to the inevitable twist or roll in the catheter shaft as it is navigated through the vasculature. For example, the controller may change an amount of wire pull or tension based on the roll angle in order to articulate the catheter tip in the desired direction. In some embodiments, this is achieved by altering the desired articulation direction by the measured roll amount.

[0064] Referring now to FIGS. 17A and 17B, when an articulation command is initiated, the controller first computes the moment required to articulate the catheter tip and then calculates how much to pull or tension the wire to generate the moment. FIGS. 17A and 17B show moments and various angles involved in the computation. If M is the desired moment and m_i is the moment generated from pulling the i^{th} wire in the catheter, the following equation describes how the desired moment is related to the moments resulting from wire pulls.

$$M(\theta) = A(\beta_1, \beta_2, \dots) m \tag{1}$$

$$\begin{bmatrix} M_x \\ M_y \end{bmatrix} = \begin{bmatrix} \cos \beta_1 & \cos \beta_2 & \dots \\ \sin \beta_1 & \sin \beta_2 & \dots \end{bmatrix} \begin{bmatrix} m_1 \\ m_2 \\ \vdots \end{bmatrix} \tag{2}$$

[0065] As shown in FIG. 17A, θ is the direction of the moment M , and β_i is the direction of the moment resulting from the i^{th} wire pull. The β_i is related to the angular position of the i^{th} wire, α_i , by a fixed amount $\pi/2$. To compute the new articulating moment direction, the measured roll angle, γ , is subtracted out from the original articulating moment direction θ to compensate for the roll. As such, a new articulating direction, θ^* , is calculated according to the following rule:

$$\theta^* = \theta - \gamma \tag{3}$$

[0066] FIGS. 18A - 23B illustrate systems and methods for integrating a magnetic encoder into a catheter for measuring

its roll. These FIGS. 18A-23B are illustrated from the perspective of being inside of the catheter-e.g., as if a camera were inside the catheter and looking out through an opening in the distal tip of the catheter. The instrumented catheter would enhance the instinctive driving experience by further improving the accuracy of catheter control.

[0067] For example, FIGS. 18A and 18B illustrate a case where γ is $\pi/2$, which means the distal tip of the catheter rolled 90 degrees in the counter clockwise direction. The rotation is around the z-axis, which points out of the screen according to the right hand rule, i.e. cross x-axis and y-axis to get the z-axis. FIG. 18A illustrates a scenario in which there is no roll. For example, an incoming command directs the controller to articulate the catheter to the right, that is $\theta = 3\pi/2$, and the controller would pull wire 1 on the right side of the catheter. With a 90 degree roll on the catheter, pulling the same wire 1 would not articulate the catheter to the right because wire 1 is now at the top of the catheter. Alternatively, a compensated controller would have a new articulating moment direction $\theta^* = \pi$ as shown in FIG. 18B and this would enable the controller to pull the correct wire, for example wire 4, to produce an articulation to the right.

[0068] Referring now to FIGS. 19A and 19B, in some embodiments, one or more encoders 1201 may be used to measure catheter roll and thus improve instinctive driving. In general, encoders are non-contact sensors with an infinite number of turns. Encoders come in optical and magnetic varieties. The optical encoder uses an optical emitter-detector pair with a patterned encoder wheel in between to detect the amount of rotation. According to the invention, a magnetic encoder 1201, shown in FIGS. 19A and 19B, uses a Hall-effect or magneto-resistive sensor 1202 to detect changes in polarity. Instead of an encoder wheel, a magnetized ring 1200 is used to provide the alternating magnetic poles along the circumference of the ring 1200. The Hall-effect sensor 1202 can detect the change in polarity as the ring 1200 turns, and the sensor 1202 produces electric pulses for angular measurements. A magnetic encoder 1201 measures relative roll between the magnetic ring 1200 and the Hall-effect sensor 1202, i.e. the read head. Typically, the sensor 1202 is fixed to a stationary object, and the magnetized ring 1200 rotates with the spinning object or vice versa.

[0069] Referring now to FIGS. 20A and 20B, the magnetic ring 1200 and the sensor 1202 may be incorporated into a catheter 1220, which may also include a distal catheter tip 1204, two rings 1208a, 1208b on either side of the ring 1200, a control ring 1206 and control wires 1210. The magnetic ring 1200 functions to rotate whenever the catheter 1220 rolls, so that the Hall-effect sensor 1202 can detect the change in roll. The ring 1200 is mounted on rails 1208a, 1208b on both sides to allow it to spin around freely as the catheter 1220 rolls, and the sensor 1202 is fixed and embedded into the catheter wall. In one embodiment, as shown in FIG. 20A, the control ring 1206 provides soldering points for the control wires 1210. Alternatively, the control ring 1206 and the proximal rail 1208b may be combined into a single ring to simplify catheter construction, and the control wires 1210 may be directly soldered to the proximal rail 1208b.

[0070] In some embodiments, a fluid bearing rather than a mechanical bearing may be used to enable the ring 1200 to freely rotate under gravitational pull in the case in which the rails 1208a, 1208b cannot significantly reduce friction. For example, the magnetized ring 1200 may be enclosed in a sealed, tube-like structure filled with low viscosity fluid to lower the friction. The operation of the Hall-effect sensor 1202 would not be affected, because it does not need to be in direct contact with the ring 1200. Alternatively, small-scale dithering may be used to constantly break friction. In some embodiments, a sound wave or any other type of external excitation signal may be used to excite the ring 1200 to break free from either the rail 1208a, 1208b or the fluid bearing.

[0071] Referring now to FIGS. 21A and 21B, in some embodiments, to achieve ring rotation when the catheter rolls, a ring 1230 may be constructed with unbalanced weight distribution, so that it stays upright regardless of catheter roll. As shown in FIGS. 21A and 21B, the ring 1230 is heavy on one side and light on the other side. Thus, the ring may rotate independently to keep the heavy side down consistently. The size of an enclosing oval 1232, as shown in FIG. 21A, demonstrates the weight distribution in the ring 1230. The weight gradually increases from the top side of the ring to the bottom side of the ring 1230, as designated by the double-headed arrow. In some embodiments, the weight distribution may change abruptly. In some embodiments, a discontinuous weight change, for example extra weight hanging from one side of the ring 1230, may maintain the ring 1230 stay upright consistently.

[0072] In some embodiments, a roll sensor may improve the control and navigation of a robotic catheter. The controller may be able to interpret user inputs quickly, based on the measured roll information and adjust its control output accordingly to increase instinctive driving of the catheter. The catheter may be articulated in the direction desired by the user with all the computation hidden from the user.

[0073] Alternatively or additionally, a roll sensor may be used for navigation with direct visualization. For example, a camera may be installed on the distal end or tip of a catheter to directly provide a visual image of the surroundings during navigation. For example, U.S. Patent Application Serial No. 13/452,029 (U.S. Pub. No. 2012/0296161), filed April 20, 2012, has further information regarding a method to obtain a clear viewing field for a camera.

[0074] Further, in some embodiments, a roll sensor may measure the absolute roll of the catheter and may be applied to a non-telescoping catheter. If the catheter is instrumented with a camera, the roll sensor can help reorient the camera view so that it displays the field of view right side up. For example, the camera view may not rotate even if the camera itself rotates, and one or more catheter controls may compensate for the catheter roll so that the catheter is manipulated instinctively under the endoscopic camera view.

[0075] FIGS. 22A and 23A illustrate a catheter 1240 from the viewpoint of a user. The catheter 1240 is equipped with

a camera 1242 at its distal tip and a roll sensor 1244 just proximal to the camera 1242. FIG. 23A illustrates the catheter 1240 rolling 90 degrees in a counter clockwise direction (flat, curved arrow). FIGS. 22B and 23B illustrate a left viewing screen 1246 and a right viewing screen 1248, which display images 1250, 1252, 1254, 1256 to the user to assist in manipulation of the catheter 1240. In FIG. 23B, the image 1254 on the left screen 1246 is an uncompensated view, and the image 1256 on the right screen 1248 is a compensated view (e.g. to keep the right side of the catheter 1240 up). The camera view on the left 1254 rotates as the camera 1242 rolls, whereas the view on the right 1256 remains the same independent of camera roll. Further, the catheter controller may recognize the change in roll and make proper adjustments to facilitate navigation. This is illustrated as the D instead of R in the right image 1256 in FIG. 23B. When it was R, as shown in the image 1252 in FIG. 22B, pulling the R wire would articulate the catheter 1240 to the right. Due to the catheter/camera roll, the relationship has changed and now the controller needs to pull the D wire instead of the R wire to articulate the catheter 1240 to the right. This modification in control algorithm is transparent to the user, and the controller would make the proper adjustment based on the roll measurement.

[0076] In some embodiments, a magnetic encoder and sensor may be placed respectively on components of a telescoping catheter, such that relative roll between inner and outer components of the telescoping catheter can be determined. For example, a roll sensor may provide relative roll measurements between the camera, and therefore the instrumented balloon catheter, and the guide catheter. Instead of the absolute roll measurement, γ , as described above, this embodiment uses a relative roll measurement, δ , to obtain a new articulating direction θ^t . This new articulation direction makes navigation intuitive from the camera's perspective. δ measures the roll of the guide catheter with respect to the camera.

$$\theta^t = \theta - \delta \quad (4)$$

[0077] For example, with respect to δ measurements, when the camera up direction aligns with the guide catheter's up direction, the relative roll measurement, γ , is zero; likewise, if the camera rolls $\pi/2$ counter clockwise, it is equivalent to the guide catheter roll of $-\pi/2$ counter clockwise.

[0078] For example, FIGS. 24A and 24B illustrate a case where the camera is rolled 90 degrees but the catheter roll remains unchanged. The front image in FIGS. 24A and 24B is a camera view, and the back image in FIGS. 24A and 24B is a catheter view. Both FIGS. 24A and 24B describe a user action to articulate the catheter to the right as seen from the camera. Notice the direction of M vector changing as the camera rolls. If the catheter is commanded to articulate right in the camera view, the articulating moment should be generated in the downward direction, i.e. $\theta = 3\pi/2$. This is relatively straightforward in FIG. 24A, but when the camera rolls, the controller modifies the command according to Equation 4. The resulting direction as shown in FIG. 14B is $\theta^t = 2\pi$ and the catheter would articulate up as the top wire becomes active. Notice that this would make the catheter articulate right in the current camera view. From the user's point of view, pressing the right button on the pendant makes the catheter articulate right in the camera view.

[0079] The above discloses a concept presented here that is for use of instrumented catheters equipped with a relative roll sensor to improve catheter control under direct visual feedback. With the help of such sensor, the user can instinctively drive the catheter while looking at the live video feed from the camera. The visual feedback is easy to interpret and intuitive to understand. As such, integrating catheter motion with camera posture is believed to be an important step toward creating a truly immersive and instinctive catheter driving experience.

[0080] Referring now to FIGS. 25A and 25B, a simulated usage of a catheter-based system 1300 for navigating and performing a procedure in a blood vessel is illustrated. The system 1300 is shown advanced through a blood vessel BV toward a branching of the vessel BV into a left branch LB and a right branch RB. The system 1300, in this embodiment, includes a guide catheter 1302 and an instrumented balloon catheter 1304, which includes a distal tip camera 1310 and a balloon 1306. The system includes roll compensation, as disclosed herein. An image 1320 (FIG. 25B) may be provided, for example to show directionality of the camera 1310, such as a camera-up arrow 1312.

[0081] The user interface may use a computer or a computer readable storage medium implementing the operation of drive and implementing the various methods described herein. In general, computing systems and/or devices, such as the processor and the user input device, may employ any of a number of computer operating systems, including, but by no means limited to, versions and/or varieties of the Microsoft Windows® operating system, the Unix operating system (e.g., the Solaris® operating system distributed by Oracle Corporation of Redwood Shores, California), the AIX UNIX operating system distributed by International Business Machines of Armonk, New York, the Linux operating system, the Mac OS X and iOS operating systems distributed by Apple Inc. of Cupertino, California, and the Android operating system developed by the Open Handset Alliance.

[0082] Computing devices generally include computer-executable instructions, where the instructions may be executable by one or more computing devices such as those listed above. Computer-executable instructions may be compiled or interpreted from computer programs created using a variety of programming languages and/or technologies, including, without limitation, and either alone or in combination, Java™, C, C++, Visual Basic, Java Script, Perl, etc. In general, a

processor (e.g., a microprocessor) receives instructions, e.g., from a memory, a computer-readable medium, etc., and executes these instructions, thereby performing one or more processes, including one or more of the processes described herein. Such instructions and other data may be stored and transmitted using a variety of computer-readable media.

[0083] A computer-readable medium (also referred to as a processor-readable medium) includes any non-transitory (e.g., tangible) medium that participates in providing data (e.g., instructions) that may be read by a computer (e.g., by a processor of a computer). Such a medium may take many forms, including, but not limited to, non-volatile media and volatile media. Non-volatile media may include, for example, optical or magnetic disks and other persistent memory. Volatile media may include, for example, dynamic random access memory (DRAM), which typically constitutes a main memory. Such instructions may be transmitted by one or more transmission media, including coaxial cables, copper wire and fiber optics, including the wires that comprise a system bus coupled to a processor of a computer. Common forms of computer-readable media include, for example, a floppy disk, a flexible disk, hard disk, magnetic tape, any other magnetic medium, a CD-ROM, DVD, any other optical medium, punch cards, paper tape, any other physical medium with patterns of holes, a RAM, a PROM, an EPROM, a FLASH-EEPROM, any other memory chip or cartridge, or any other medium from which a computer can read.

[0084] Databases, data repositories or other data stores described herein may include various kinds of mechanisms for storing, accessing, and retrieving various kinds of data, including a hierarchical database, a set of files in a file system, an application database in a proprietary format, a relational database management system (RDBMS), etc. Each such data store is generally included within a computing device employing a computer operating system such as one of those mentioned above, and are accessed via a network in any one or more of a variety of manners. A file system may be accessible from a computer operating system, and may include files stored in various formats. An RDBMS generally employs the Structured Query Language (SQL) in addition to a language for creating, storing, editing, and executing stored procedures, such as the PL/SQL language mentioned above.

[0085] In some examples, system elements may be implemented as computer-readable instructions (e.g., software) on one or more computing devices (e.g., servers, personal computers, etc.), stored on computer readable media associated therewith (e.g., disks, memories, etc.). A computer program product may comprise such instructions stored on computer readable media for carrying out the functions described herein.

[0086] The exemplary illustrations are not limited to the previously described examples. Rather, multiple variants and modifications are possible, which also make use of the ideas of the exemplary illustrations and therefore fall within the protective scope. Accordingly, it is to be understood that the above description is intended to be illustrative and not restrictive.

[0087] With regard to the processes, systems, methods, heuristics, etc. described herein, it should be understood that, although the steps of such processes, etc. have been described as occurring according to a certain ordered sequence, such processes could be practiced with the described steps performed in an order other than the order described herein. It further should be understood that certain steps could be performed simultaneously, that other steps could be added, or that certain steps described herein could be omitted. In other words, the descriptions of processes herein are provided for the purpose of illustrating certain embodiments, and should in no way be construed so as to limit the claimed invention.

[0088] Accordingly, it is to be understood that the above description is intended to be illustrative and not restrictive. Many embodiments and applications other than the examples provided would be upon reading the above description. The scope of the invention should be determined, not with reference to the above description, but should instead be determined with reference to the appended claims, along with the full scope of equivalents to which such claims are entitled. It is anticipated and intended that future developments will occur in the arts discussed herein, and that the disclosed systems and methods will be incorporated into such future embodiments. In sum, it should be understood that the invention is capable of modification and variation and is limited only by the following claims.

[0089] All terms used in the claims are intended to be given their broadest reasonable constructions and their ordinary meanings as understood by those skilled in the art unless an explicit indication to the contrary is made herein. In particular, use of the singular articles such as "a," "an," "the," etc. should be read to recite one or more of the indicated elements unless a claim recites an explicit limitation to the contrary.

Claims

1. A robotic catheter system, comprising:

a flexible catheter (1220) having a proximal end, a distal end, and an articulating portion at the distal end;
 a sensor for measuring catheter roll at the distal end of the catheter;
 a camera (1242) on the distal end of the catheter (1220) to provide a visual image of the surroundings during navigation;

a controller (400) coupled with the proximal end of the flexible catheter (1220) to receive a user input and articulate the articulating portion of the catheter (1220) in response to the user input; a visual display (1246, 1248) for displaying the visual image from the camera (1242); a processor configured to reorient a displayed camera view of the visual image to
 5 compensate for catheter roll at the distal end of the catheter (1220),

characterized in that

the sensor is a magnetic encoder (1201) for measuring catheter roll at the distal end of the catheter (1220), wherein the magnetic encoder (1201) comprises a magnetic ring (1200) that rotates whenever the flexible catheter rotates and a magnetic sensor (1202), wherein the magnetic encoder (1201) measures relative roll
 10 between the magnetic ring (1200) and the magnetic sensor (1202).

2. The system of Claim 1, wherein the controller is configured to recognize catheter roll of the catheter (1220) and make adjustments to facilitate navigation by compensating for the catheter roll.
- 15 3. The system of Claim 2, wherein adjustments to facilitate navigation include altering a desired articulation direction by a measured roll amount.
4. The system of Claim 2 or 3, wherein making adjustments to facilitate navigation by compensating for the catheter roll is transparent to the user.
- 20 5. The system of Claim 2, 3 or 4, wherein the adjustments to facilitate navigation include changing the relationship between the controller and pull wires (422, 424, 425) used to articulate the flexible catheter (1220).
- 25 6. The system of Claim 2, 3, 4 or 5 wherein the adjustments to facilitate navigation include changing an amount of wire pull or tension based on a roll angle.
7. The system of any of claims 1 to 5, wherein the sensor (1200) comprises a ring (1230) with unbalanced weight distribution so that it stays upright regardless of catheter roll.
- 30 8. The system of any preceding claim, wherein the reoriented displayed camera view corresponds to right side up view.
9. The system of any preceding claim, wherein the visual display (1246, 1248) is configured to display an image from the camera (1242) that is compensated for catheter roll.
- 35 10. The system of Claim 9, wherein the visual display (1246, 1248) is configured to display an image from the camera (1242) that is compensated for catheter roll, the displaying being transparent to the user.
- 40 11. The system of any of claims 1 to 8, wherein the visual display (1246, 1248) is configured to display an image from the camera (1220) that is uncompensated for catheter roll and an image from the catheter that is compensated for catheter roll.
12. The system of any preceding claim, wherein the magnetic ring (1200) is coupled to a pair of rings (1208a, 1208b).

Patentansprüche

1. Roboterhaftes Kathetersystem, das Folgendes umfasst:

einen flexiblen Katheter (1220) mit einem proximalen Ende, einem distalen Ende und einem Artikulationsabschnitt am distalen Ende;
 50 einen Sensor zum Messen eines Katheterrollens am distalen Ende des Katheters;
 eine Kamera (1242) am distalen Ende des Katheters (1220) zum Bereitstellen eines optischen Bildes der Umgebung während einer Navigation;
 eine Steuerung (400), gekoppelt mit dem proximalen Ende des flexiblen Katheters (1220) zum Empfangen einer Benutzereingabe und zum Artikulieren des Artikulationsabschnitts des Katheters (1220) als Reaktion auf
 55 die Benutzereingabe;
 eine optische Anzeige (1246, 1248) zum Anzeigen des optischen Bildes von der Kamera (1242);
 einen Prozessor, der zum Neuausrichten einer angezeigten Kameraansicht des optischen Bildes konfiguriert ist,

EP 3 243 476 B1

um ein Katheterrollen am distalen Ende des Katheters (1220) zu kompensieren,

dadurch gekennzeichnet, dass der Sensor ein magnetischer Messgeber (1201) zum Messen eines Katheterrollens am distalen Ende des Katheters (1220) ist, wobei der magnetische Messgeber (1201) einen magnetischen Ring (1200), der sich jedes Mal dreht, wenn der flexible Katheter sich dreht, und einen magnetischen Sensor (1202) umfasst, wobei der magnetische Messgeber (1201) ein relatives Rollen zwischen dem magnetischen Ring (1200) und dem magnetischen Sensor (1202) misst.

2. System nach Anspruch 1, wobei die Steuerung zum Erkennen eines Katheterrollens des Katheters (1220) und zum Vornehmen von Justierungen zum Erleichtern einer Navigation durch Kompensieren des Katheterrollens konfiguriert ist.
3. System nach Anspruch 2, wobei Justierungen zum Erleichtern einer Navigation ein Modifizieren einer gewünschten Artikulationsrichtung um einen gemessenen Rollumfang beinhalten.
4. System nach Anspruch 2 oder 3, wobei das Vornehmen von Justierungen zum Erleichtern einer Navigation durch Kompensieren des Katheterrollens für den Benutzer erkennbar ist.
5. System nach Anspruch 2, 3 oder 4, wobei die Justierungen zum Erleichtern einer Navigation ein Ändern der Beziehung zwischen der Steuerung und Zugdrähten (422, 424, 425), die zum Artikulieren des flexiblen Katheters (1220) verwendet werden, beinhalten.
6. System nach Anspruch 2, 3, 4 oder 5, wobei die Justierungen zum Erleichtern einer Navigation ein Ändern eines Umfangs eines Drahtzugs oder einer Drahtspannung auf der Basis eines Rollwinkels beinhalten.
7. System nach einem der Ansprüche 1 bis 5, wobei der Sensor (1200) einen Ring (1230) mit unausgewogener Gewichtsverteilung umfasst, so dass er ungeachtet eines Katheterrollens vertikal bleibt.
8. System nach einem vorherigen Anspruch, wobei die neuausgerichtete Kameraansicht einer Draufsicht von der rechten Seite entspricht.
9. System nach einem vorherigen Anspruch, wobei die optische Anzeige (1246, 1248) zum Anzeigen eines Bilds von der Kamera (1242), das auf ein Katheterrollen kompensiert ist, konfiguriert ist.
10. System nach Anspruch 9, wobei die optische Anzeige (1246, 1248) zum Anzeigen eines Bilds von der Kamera (1242), das auf ein Katheterrollen kompensiert ist, konfiguriert ist, wobei das Anzeigen für den Benutzer erkennbar ist.
11. System nach einem der Ansprüche 1 bis 8, wobei die optische Anzeige (1246, 1248) zum Anzeigen eines Bilds von der Kamera (1220), das nicht auf ein Katheterrollen kompensiert ist, und eines Bilds von dem Katheter, das auf ein Katheterrollen kompensiert ist, konfiguriert ist.
12. System nach einem vorherigen Anspruch, wobei der magnetische Ring (1200) an ein Paar von Ringen (1208a, 1208b) gekoppelt ist.

Revendications

1. Système de cathéter robotisé, comprenant :

un cathéter flexible (1220) comportant une extrémité proximale, une extrémité distale, et une partie articulée à l'extrémité distale ;

un capteur pour mesurer le mouvement de roulis du cathéter à l'extrémité distale du cathéter ;

une caméra (1242) sur l'extrémité distale du cathéter (1220) pour fournir une image visuelle de l'environnement durant la navigation ;

un contrôleur (400) couplé à l'extrémité proximale du cathéter flexible (1220) pour recevoir une saisie utilisateur et articuler la partie articulée du cathéter (1220) en réponse à la saisie utilisateur ;

un affichage visuel (1246, 1248) pour afficher l'image visuelle provenant de la caméra (1242) ;

un processeur configuré pour réorienter une vue affichée de l'image visuelle provenant de la caméra afin de compenser le mouvement de roulis du cathéter à l'extrémité distale du cathéter (1220), **caractérisé en ce que**

EP 3 243 476 B1

le capteur est un codeur magnétique (1201) pour mesurer le mouvement de roulis du cathéter à l'extrémité distale du cathéter (1220), dans lequel le codeur magnétique (1201) comprend un anneau magnétique (1200) qui tourne chaque fois que le cathéter flexible tourne et un capteur magnétique (1202), dans lequel le codeur magnétique (1201) mesure le mouvement de roulis relatif entre l'anneau magnétique (1200) et le capteur magnétique (1202).

5

2. Système selon la revendication 1, dans lequel le contrôleur est configuré pour reconnaître le mouvement de roulis de cathéter du cathéter (1220) et faire des ajustements visant à faciliter la navigation en compensant le mouvement de roulis du cathéter.

10

3. Système selon la revendication 2, dans lequel les ajustements visant à faciliter la navigation comprennent le changement d'une direction d'articulation souhaitée dans une mesure correspondant à l'importance du mouvement de roulis mesuré.

15

4. Système selon la revendication 2 ou 3, dans lequel les ajustements visant à faciliter la navigation en compensant le mouvement de roulis du cathéter constituent une opération transparente pour l'utilisateur.

20

5. Système selon la revendication 2, 3 ou 4, dans lequel les ajustements visant à faciliter la navigation comprennent un changement de la relation entre le contrôleur et des fils de traction (422, 424, 425) utilisés pour articuler le cathéter flexible (1220).

6. Système selon la revendication 2, 3, 4 ou 5, dans lequel les ajustements visant à faciliter la navigation comprennent le changement d'un degré de traction ou de tension des fils en fonction d'un angle de roulis.

25

7. Système selon l'une quelconque des revendications 1 à 5, dans lequel le capteur (1200) comprend un anneau (1230) dont le poids est réparti de façon déséquilibrée de telle sorte qu'il reste droit indépendamment du mouvement de roulis du cathéter.

30

8. Système selon l'une quelconque des revendications précédentes, dans lequel la vue affichée provenant de la caméra qui a été réorientée correspond à la vue du côté droit vers le haut.

35

9. Système selon l'une quelconque des revendications précédentes, dans lequel l'affichage visuel (1246, 1248) est configuré pour afficher une image provenant de la caméra (1242) qui a fait l'objet d'une compensation du mouvement de roulis du cathéter.

10. Système selon la revendication 9, dans lequel l'affichage visuel (1246, 1248) est configuré pour afficher une image provenant de la caméra (1242) qui a fait l'objet d'une compensation du mouvement de roulis du cathéter, l'affichage étant transparent pour l'utilisateur.

40

11. Système selon l'une quelconque des revendications 1 à 8, dans lequel l'affichage visuel (1246, 1248) est configuré pour afficher une image provenant de la caméra (1220) qui n'a pas fait l'objet d'une compensation du mouvement de roulis du cathéter et une image provenant du cathéter qui a fait l'objet d'une compensation du mouvement de roulis du cathéter.

45

12. Système selon l'une quelconque des revendications précédentes, dans lequel l'anneau magnétique (1200) est couplé à une paire d'anneaux (1208a, 1208b).

50

55

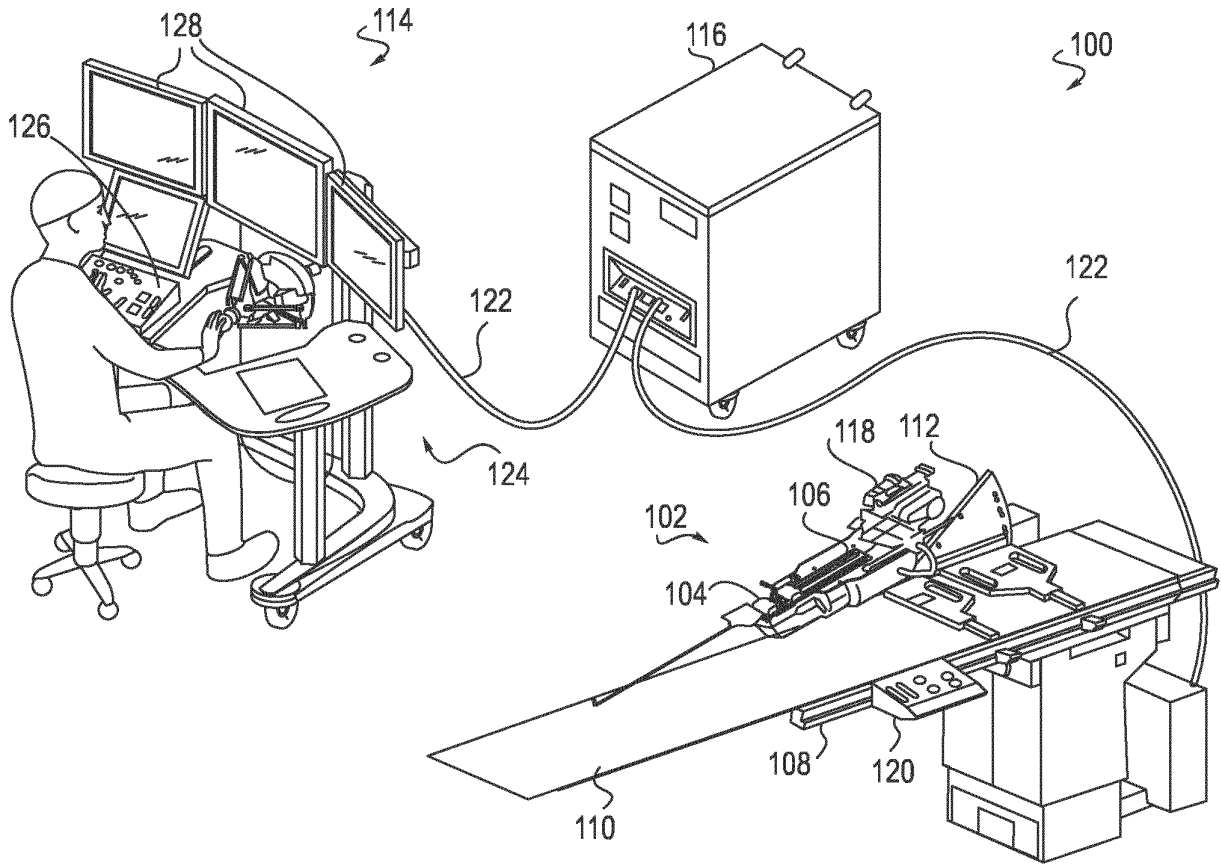

FIG. 1A

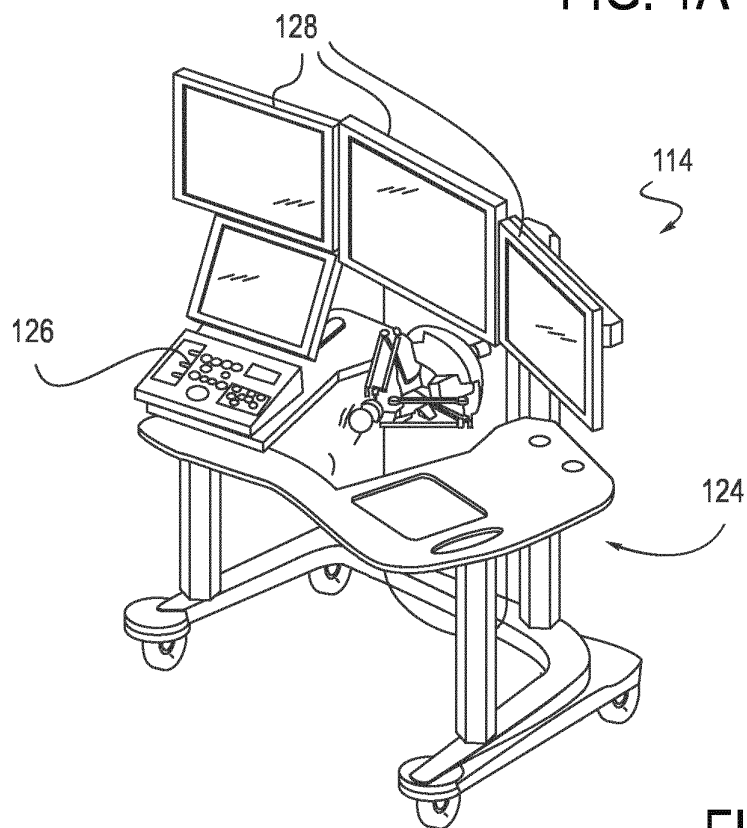

FIG. 1B

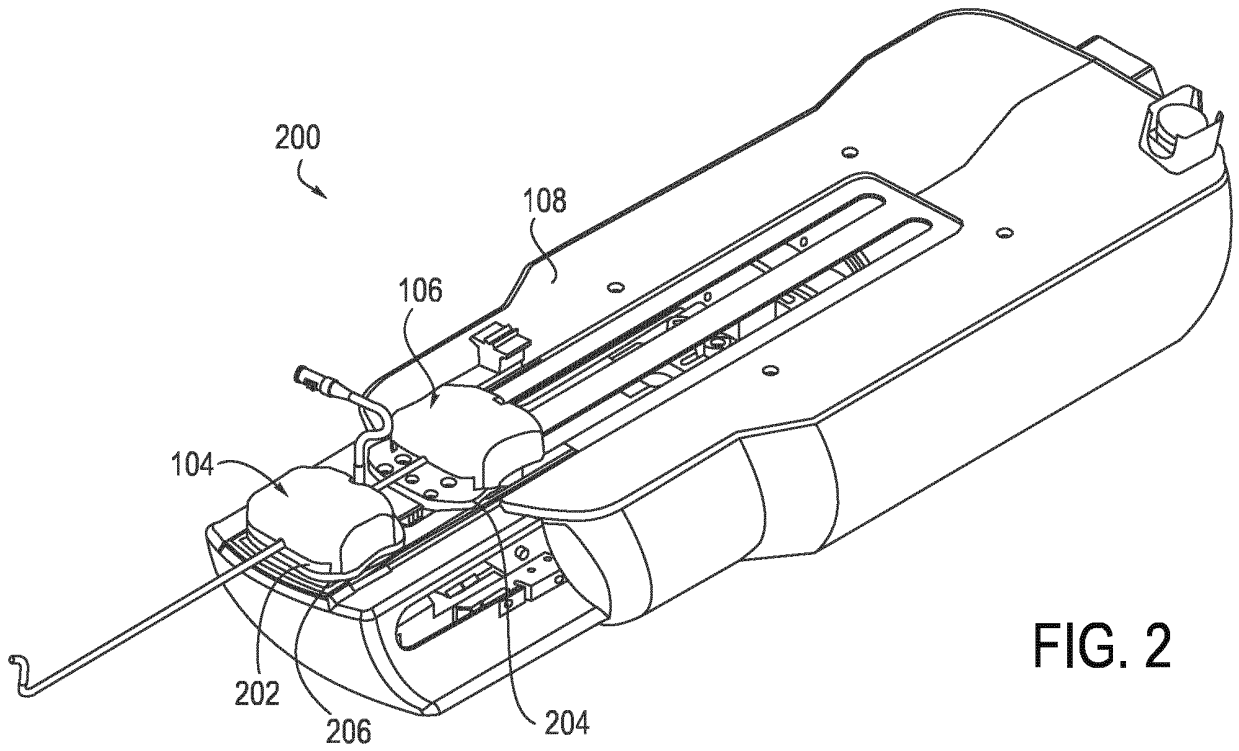

FIG. 2

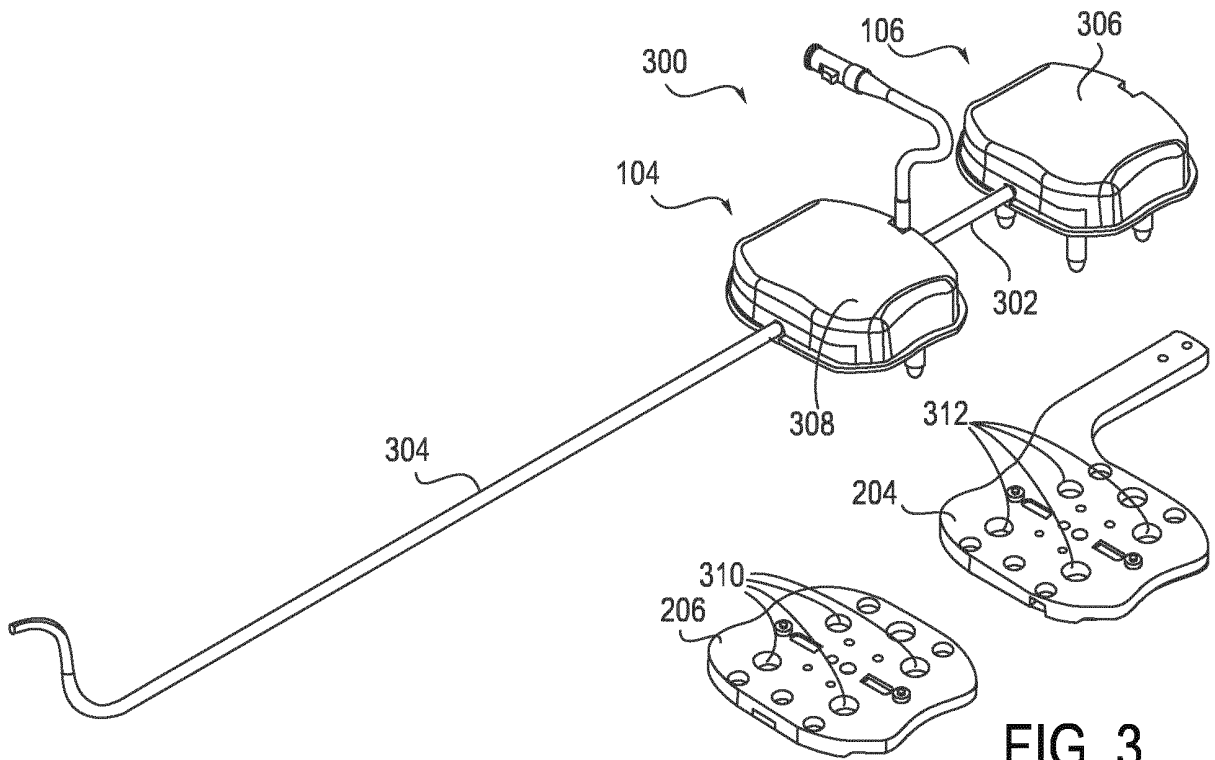

FIG. 3

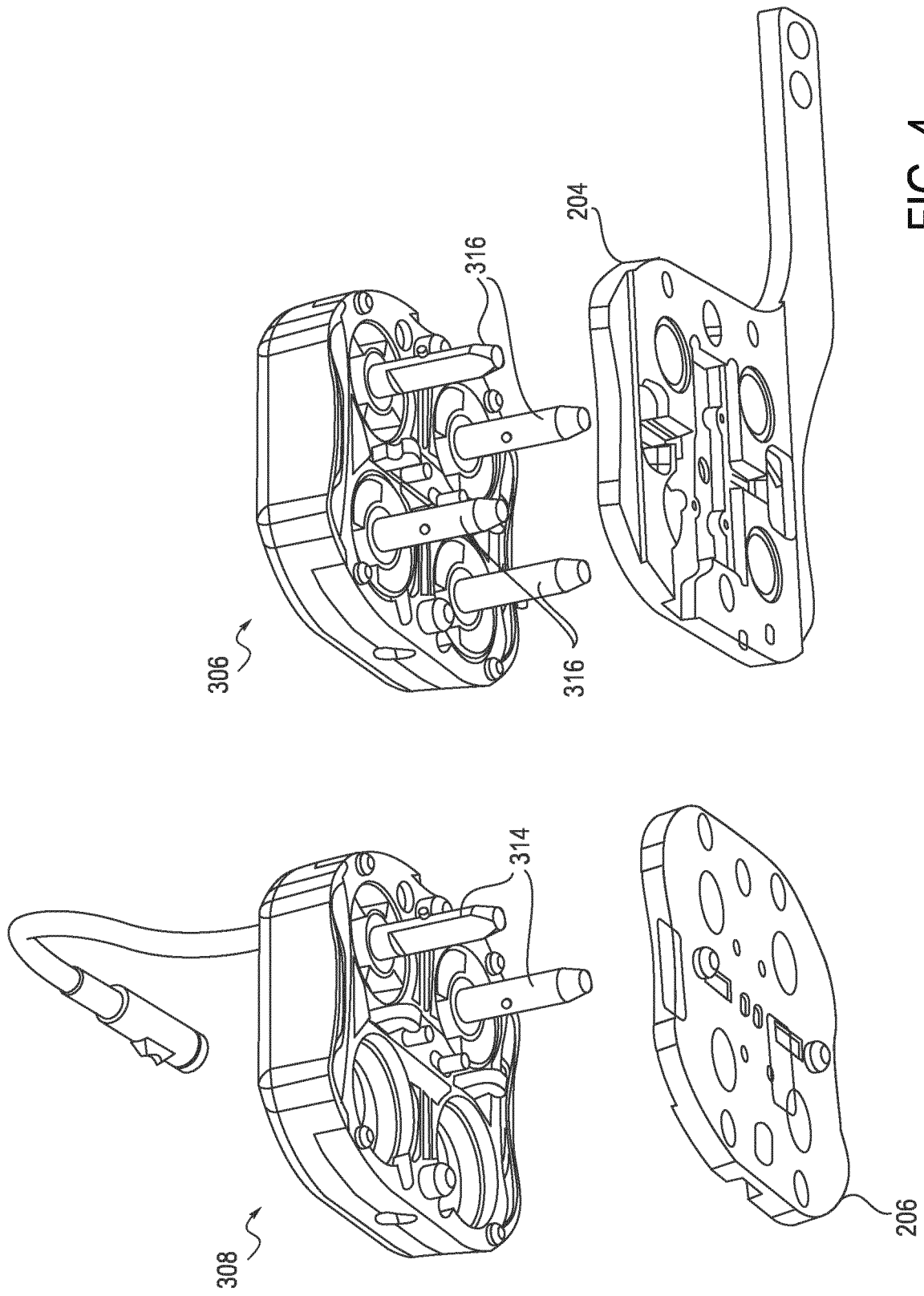

FIG. 4

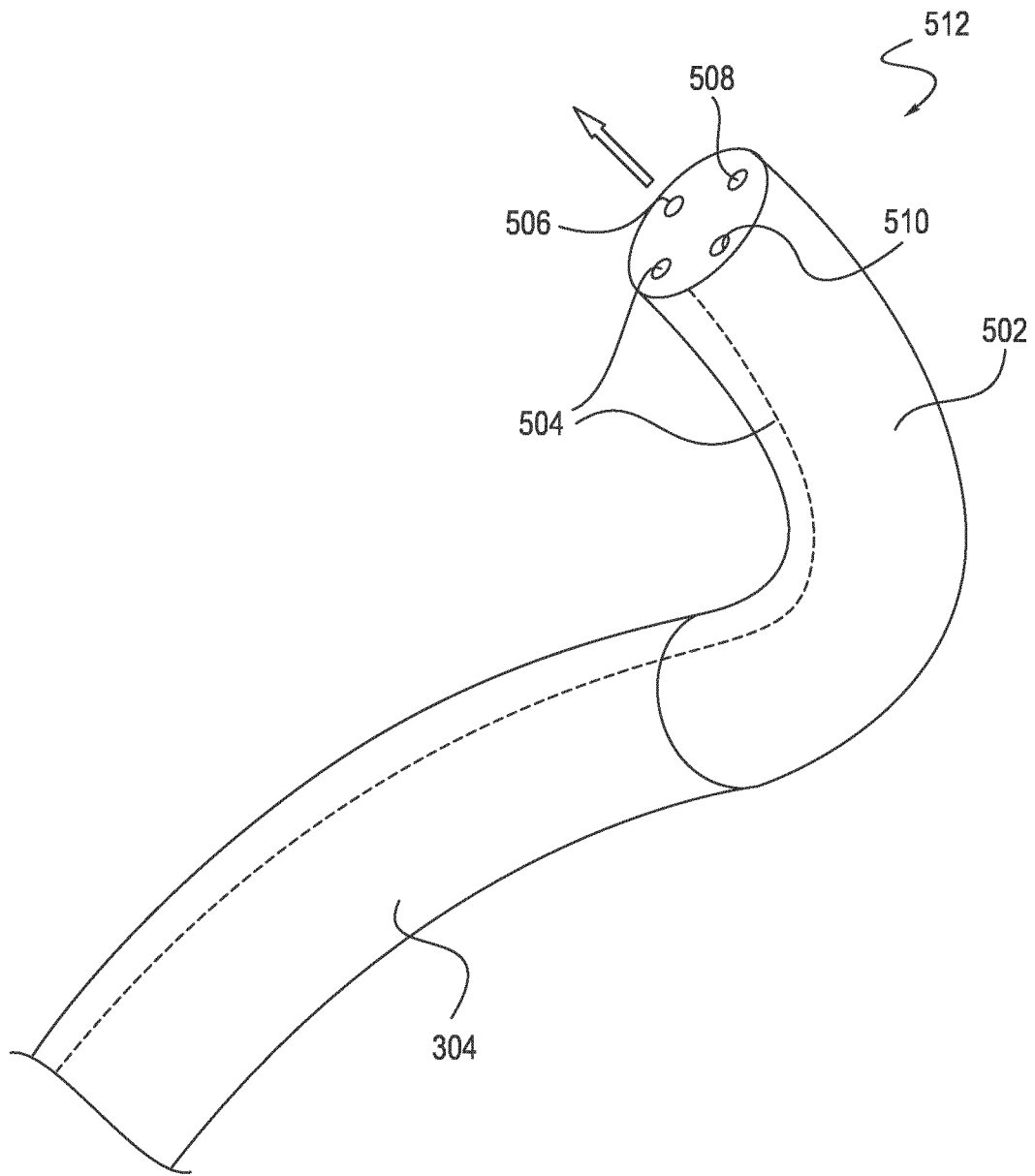

FIG. 5

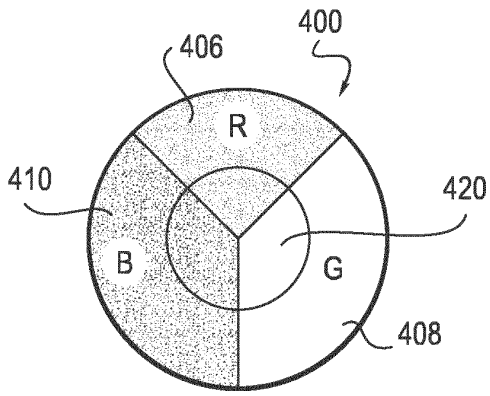

FIG. 6A

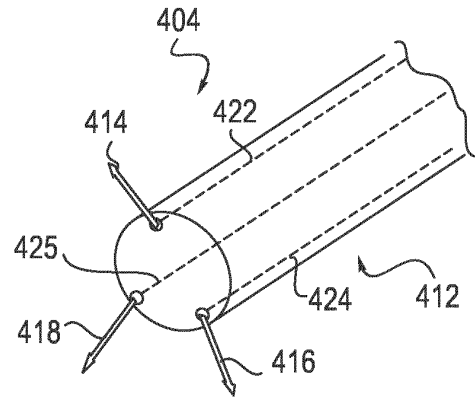

FIG. 6B

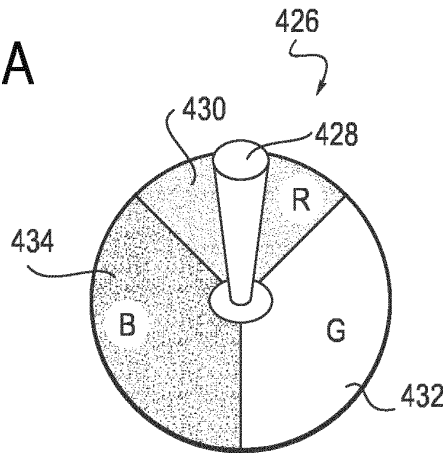

FIG. 6C

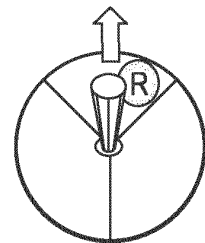
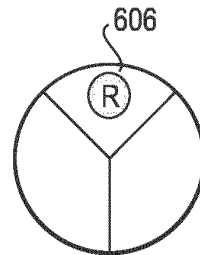
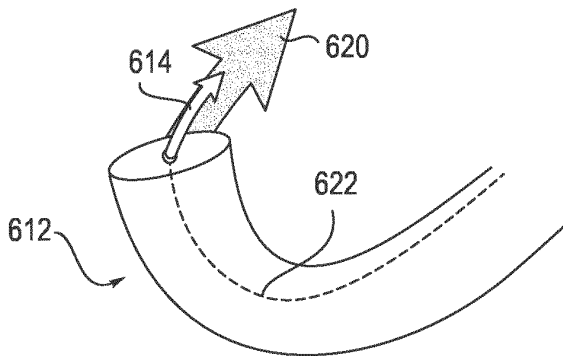

FIG. 7A

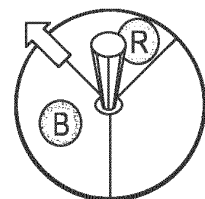
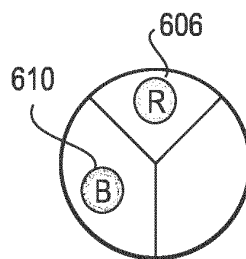
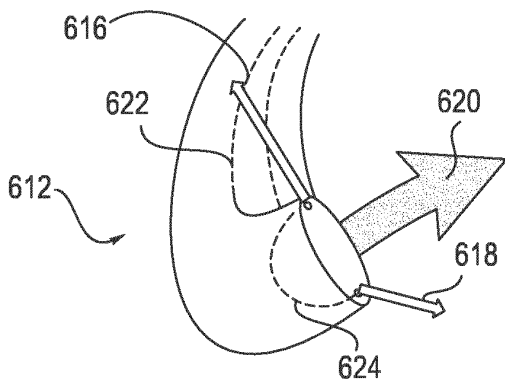

FIG. 7B

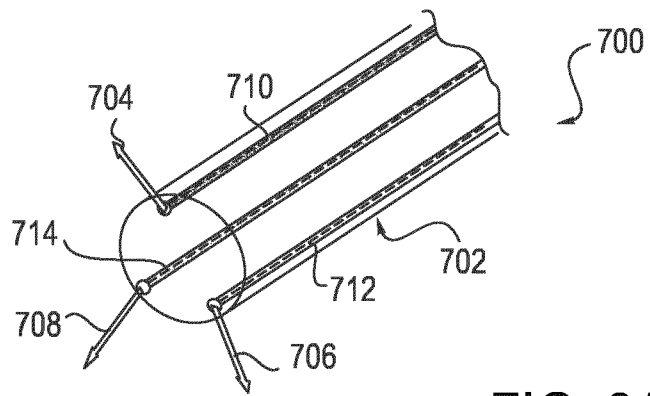

FIG. 8A

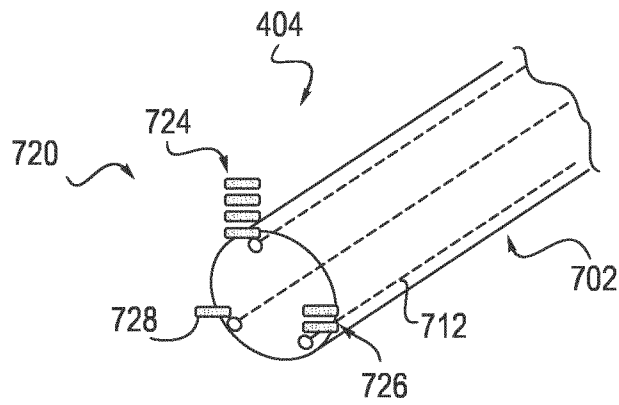

FIG. 8B

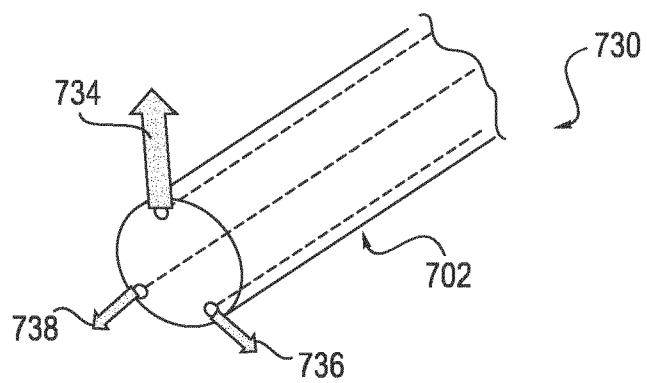

FIG. 8C

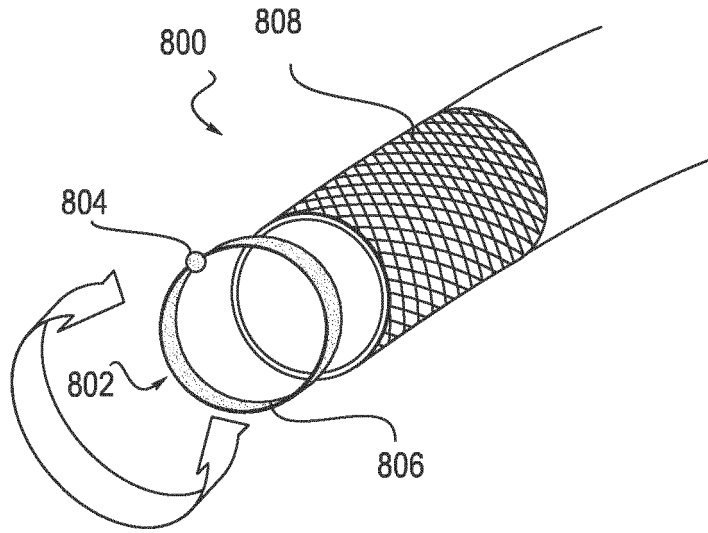

FIG. 9A

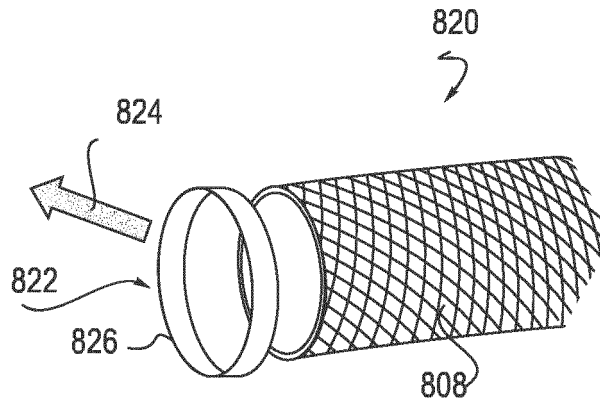

FIG. 9B

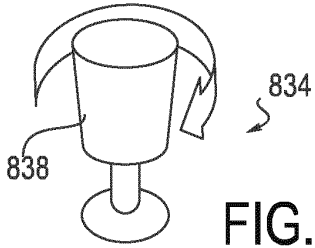
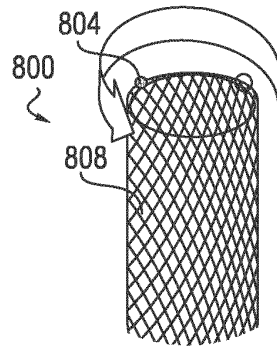
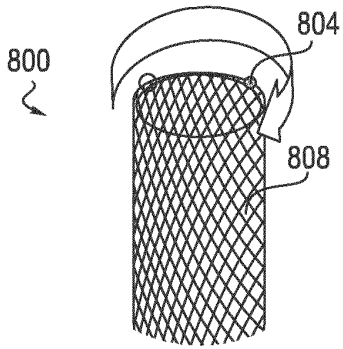

FIG. 10A

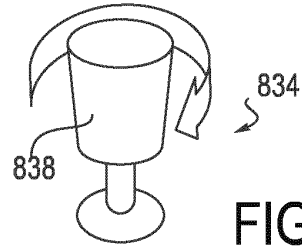

FIG. 10B

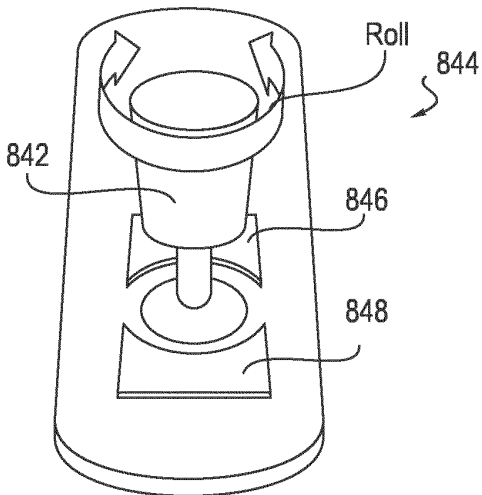

FIG. 11A

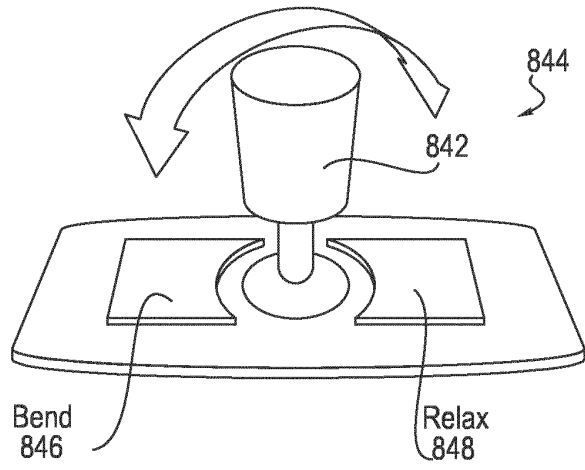

FIG. 11B

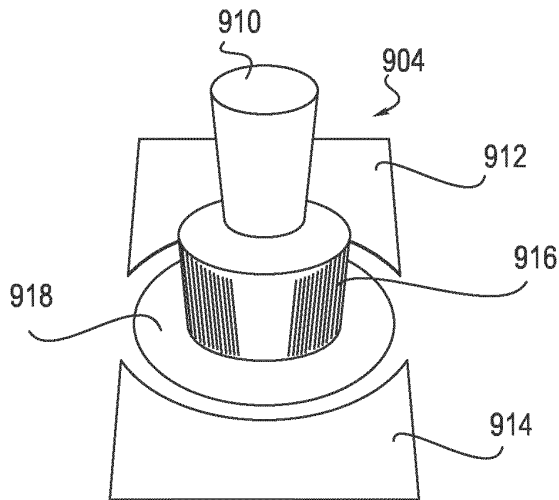

FIG. 12

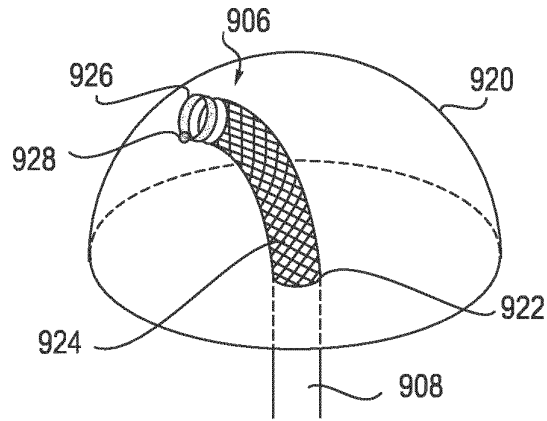

FIG. 13

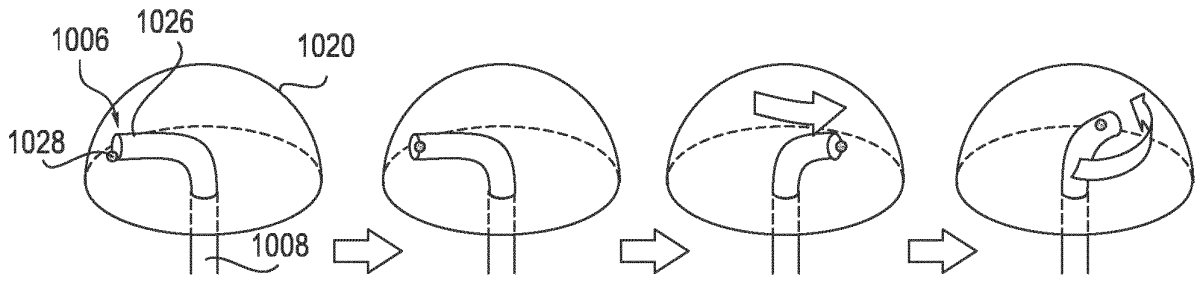

FIG. 14A

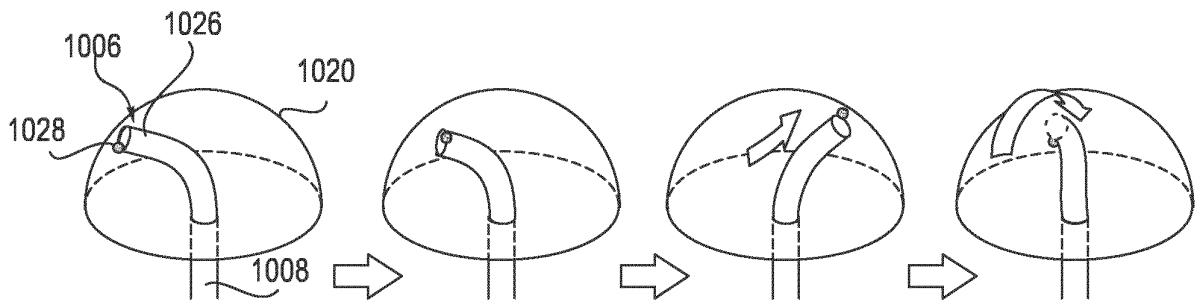

FIG. 14B

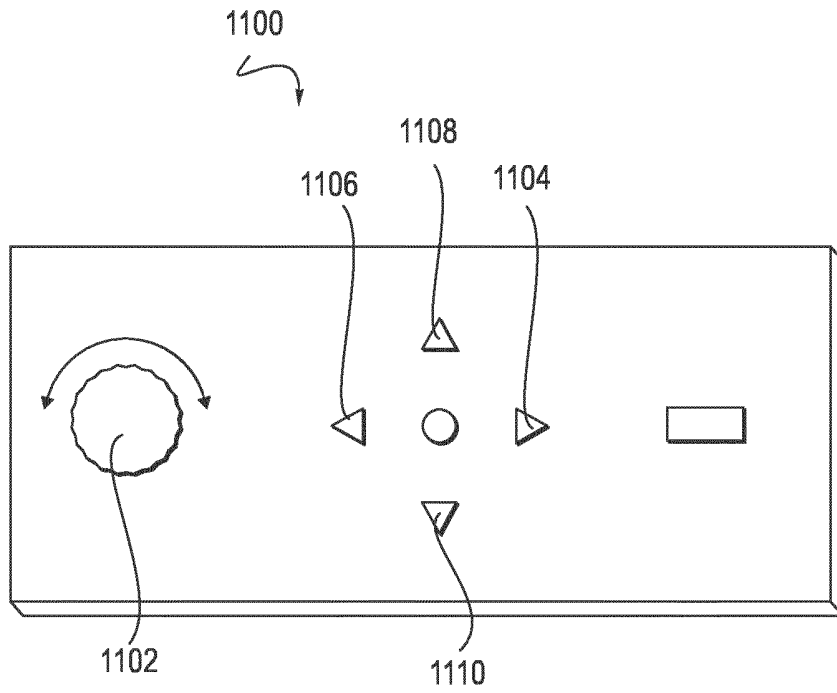

FIG. 15A

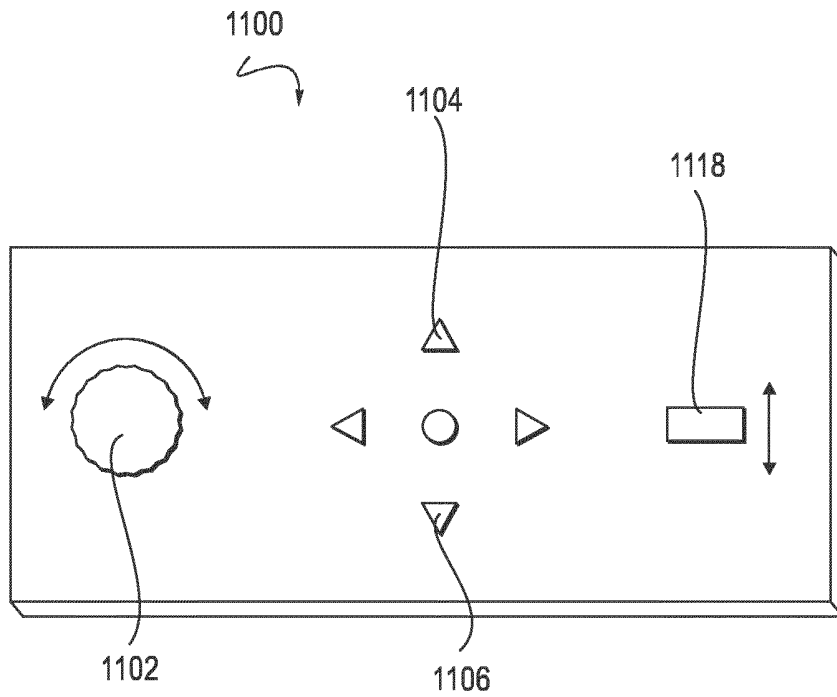

FIG. 15B

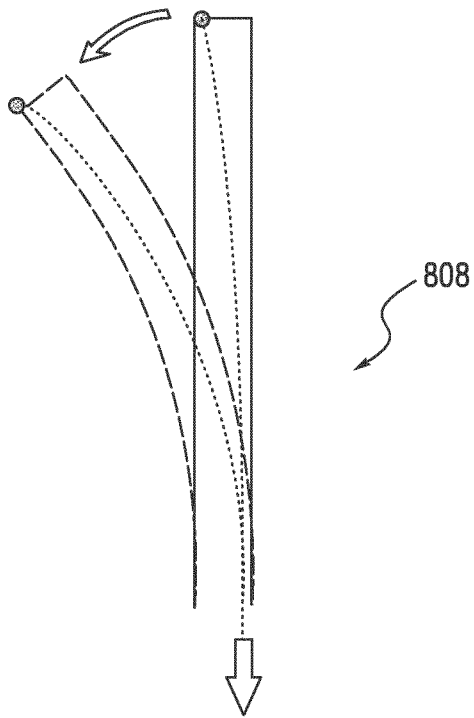

FIG. 16

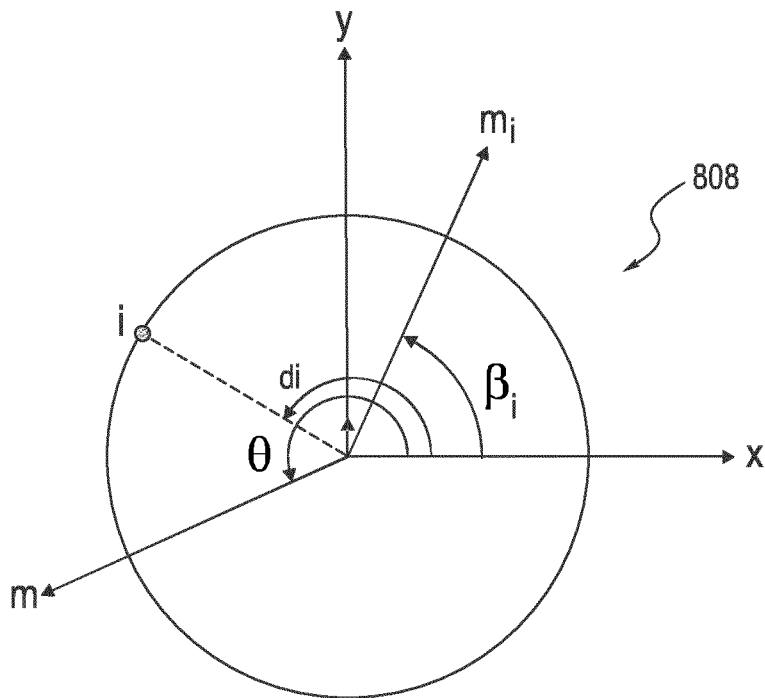

FIG. 17A

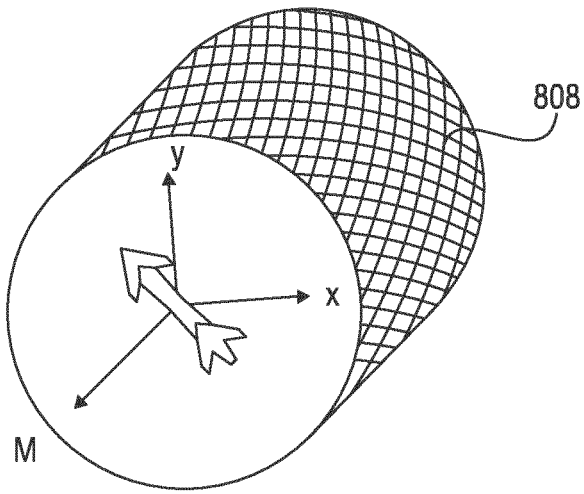

FIG. 17B

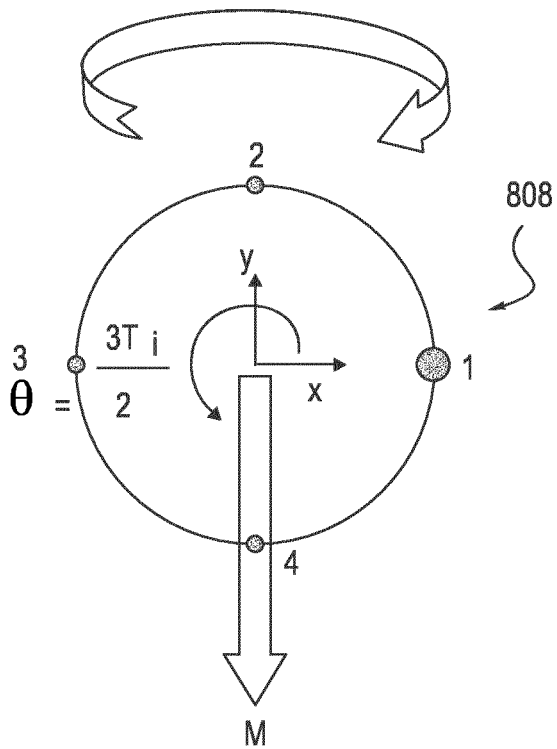

FIG. 18A

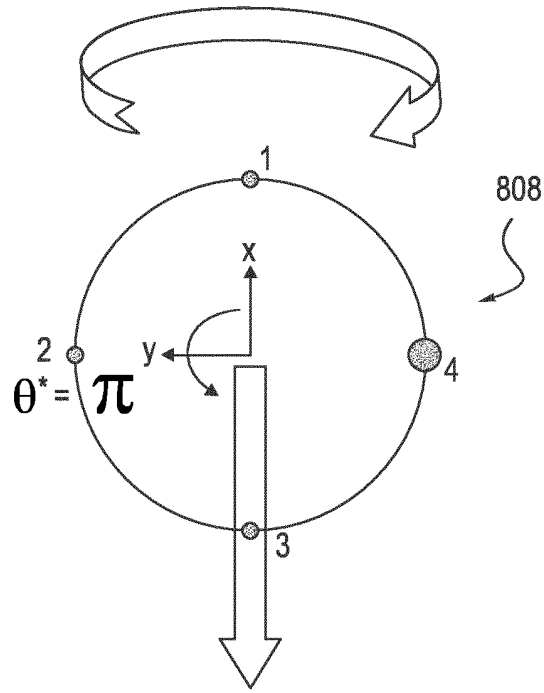

FIG. 18B

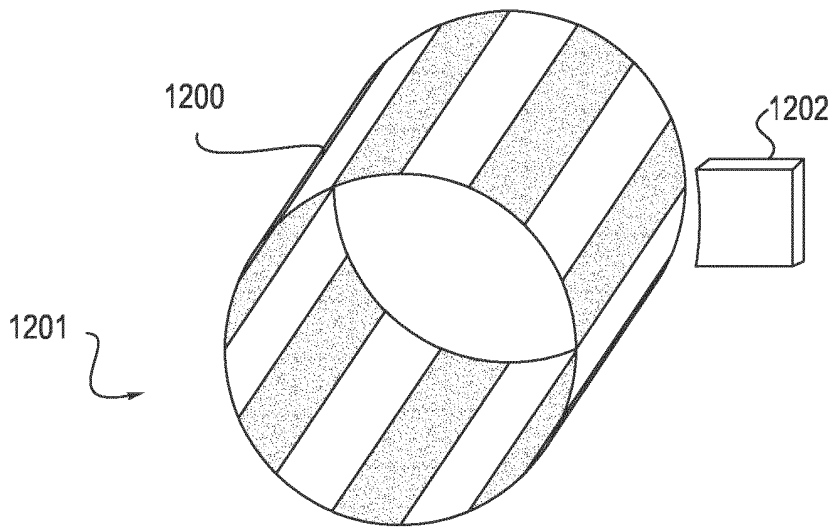

FIG. 19A

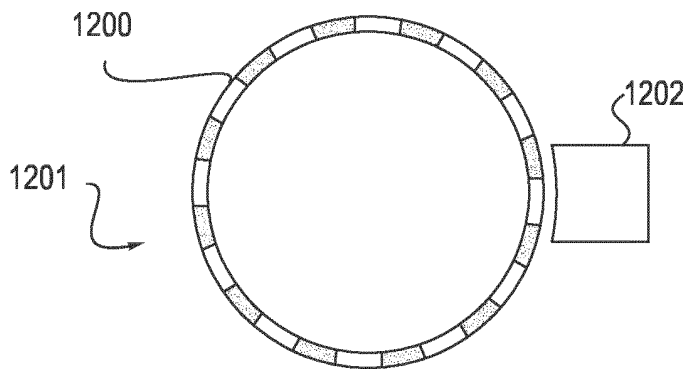

FIG. 19B

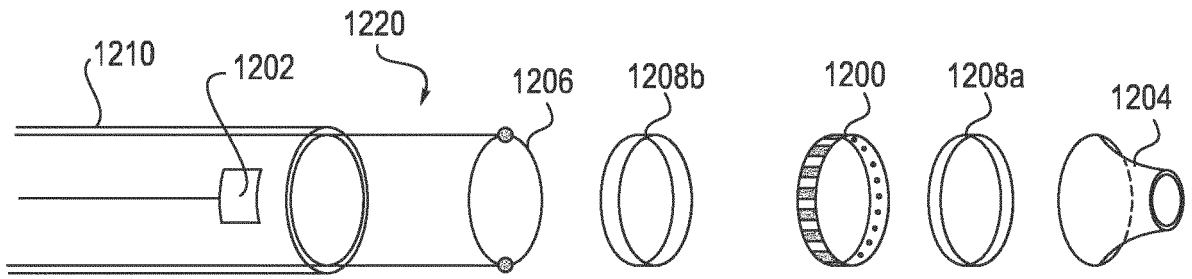

FIG. 20A

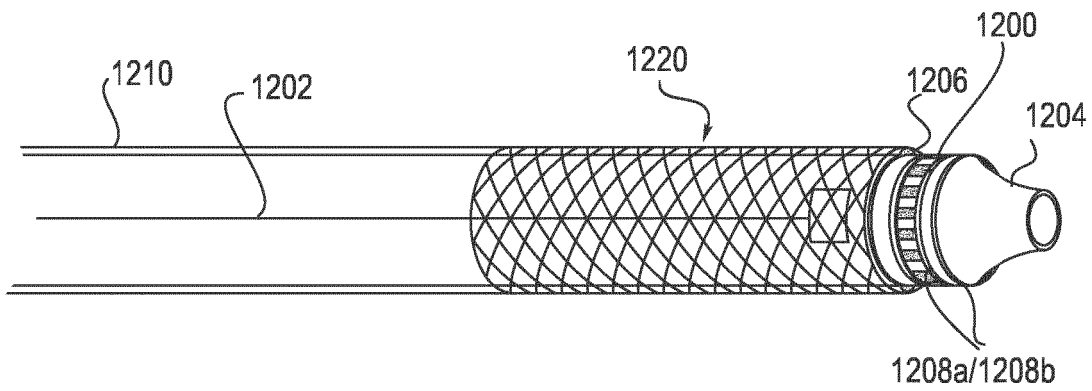

FIG. 20B

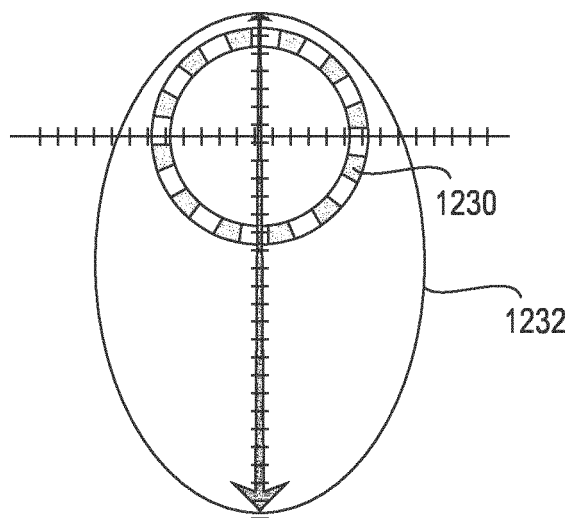

FIG. 21A

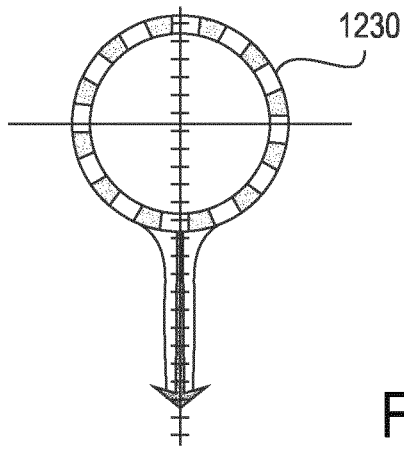

FIG. 21B

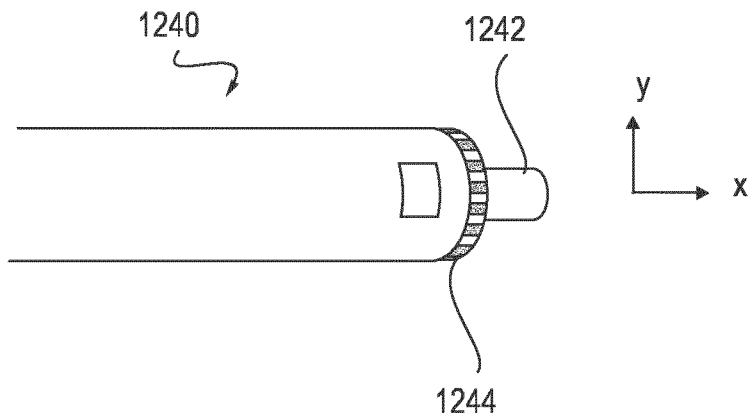

FIG. 22A

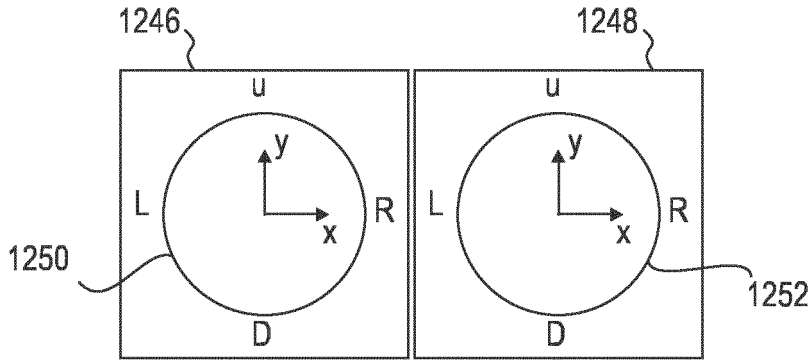

FIG. 22B

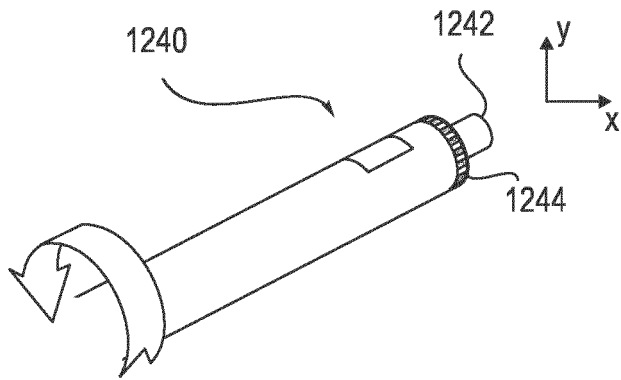

FIG. 23A

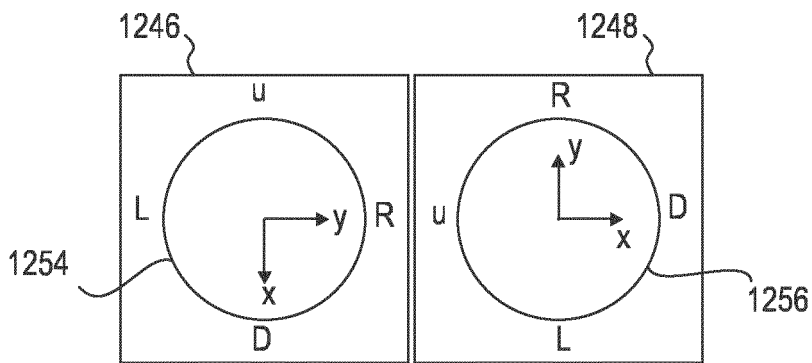

FIG. 23B

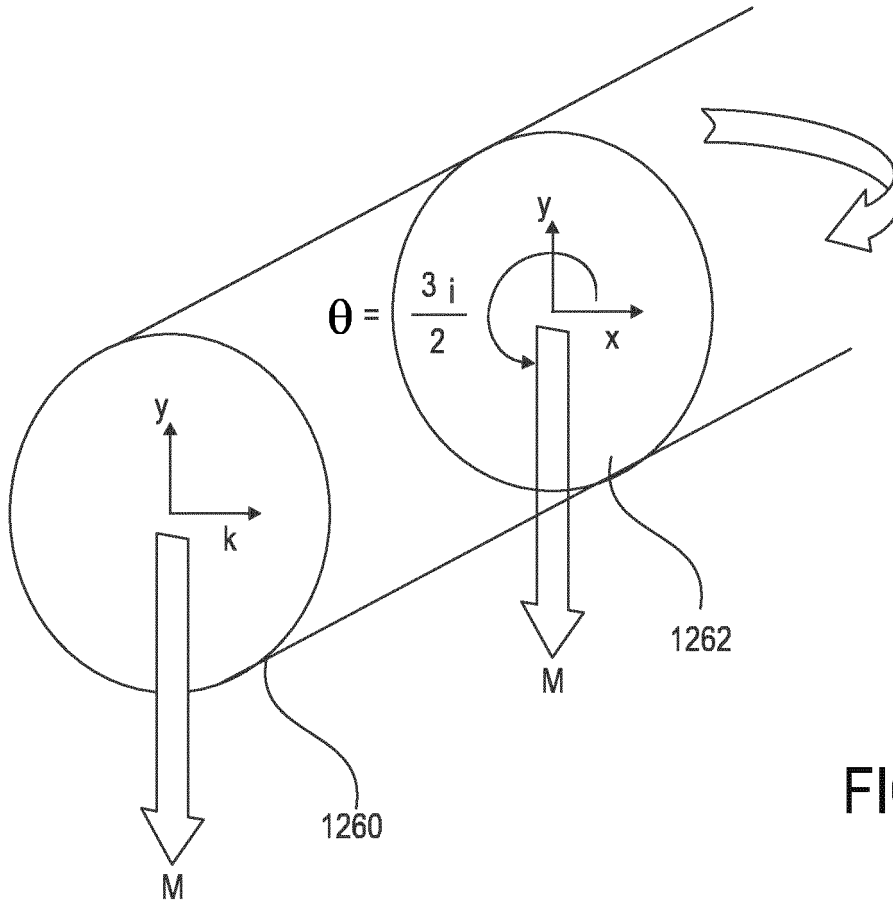

FIG. 24A

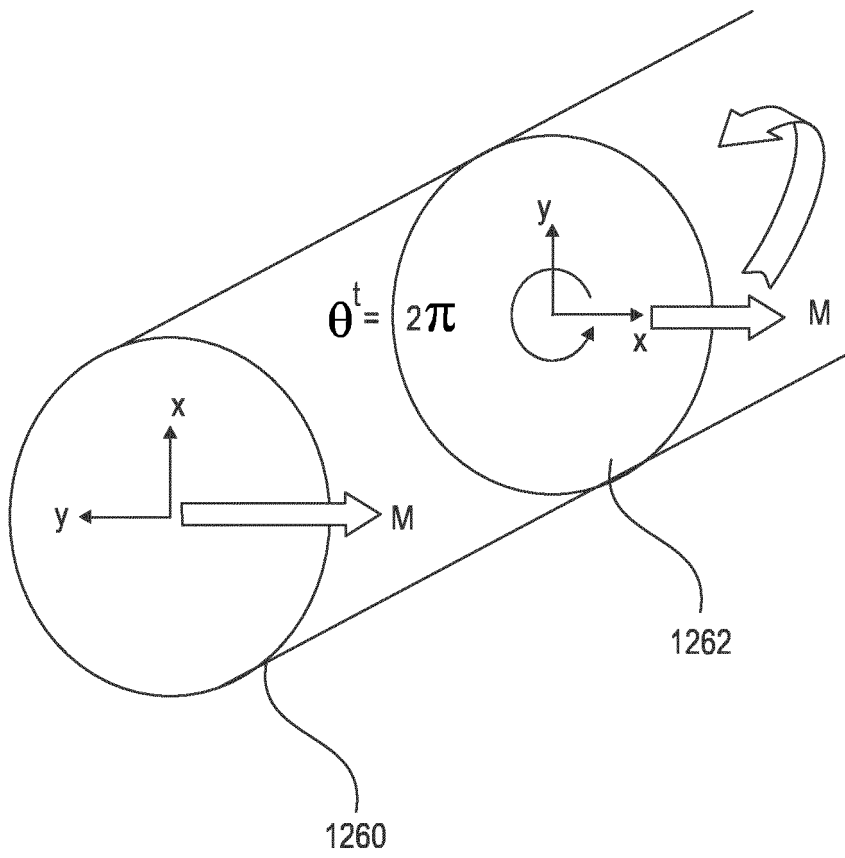

FIG. 24B

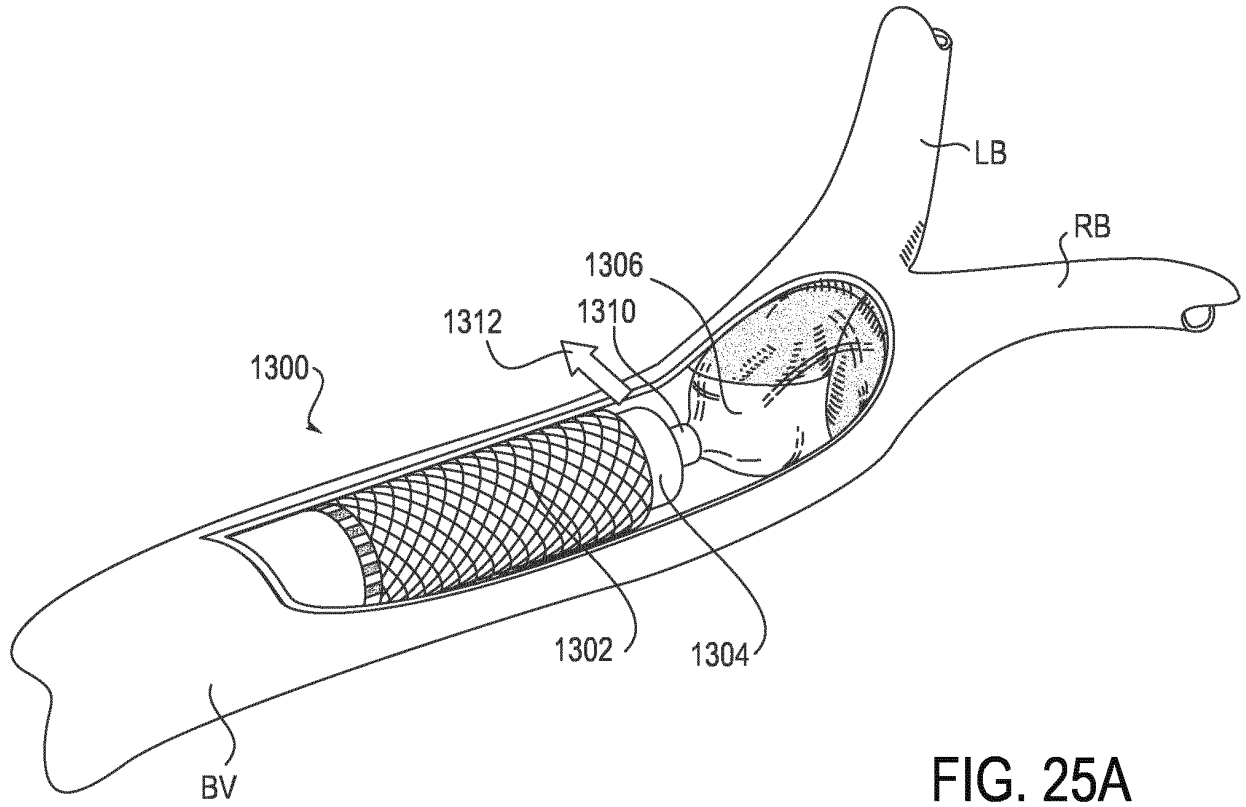

FIG. 25A

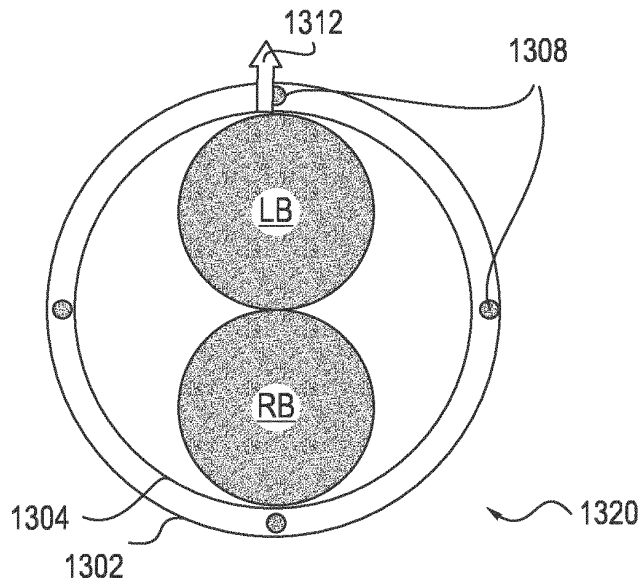

FIG. 25B

REFERENCES CITED IN THE DESCRIPTION

This list of references cited by the applicant is for the reader's convenience only. It does not form part of the European patent document. Even though great care has been taken in compiling the references, errors or omissions cannot be excluded and the EPO disclaims all liability in this regard.

Patent documents cited in the description

- US 2011196199 A [0008]
- US 452029 [0073]
- US 20120296161 A [0073]

专利名称(译)	支持即时处理的Kitheter系统和设备		
公开(公告)号	EP3243476B1	公开(公告)日	2019-11-06
申请号	EP2017177593	申请日	2015-03-23
[标]申请(专利权)人(译)	航生医疗公司		
申请(专利权)人(译)	HANSEN MEDICAL , INC.		
[标]发明人	PARK JUNE DAMBROSIO RAY WALKER SEAN P		
发明人	PARK, JUNE D'AMBROSIO, RAY WALKER, SEAN P.		
IPC分类号	A61B34/30 A61B5/06 A61B5/00 A61B34/00 A61M25/01 A61B34/10		
CPC分类号	A61B34/25 A61B34/30 A61B2034/102 A61B2034/301 A61B2034/742 Y10S901/02 A61B5/06 A61B5/7425 A61M25/0133		
优先权	61/969496 2014-03-24 US 61/983191 2014-04-23 US		
其他公开文献	EP3243476A1		
外部链接	Espacenet		

摘要(译)

机器人导管系统可包括柔性导管，该柔性导管具有近端，远端和在远端处的铰接部分。它可以进一步包括在远端处或附近与柔性导管耦合的传感器，用于显示柔性导管的至少一部分的图像的视觉显示器，用于生成显示在柔性导管的图像上的虚拟指示器的处理器，其中，虚拟指示器指示导管的关节运动部分的关节运动方向和/或关节运动量，以及控制器，该控制器与柔性导管的近端耦接，以接收用户输入并关节运动导管的关节运动部分。响应用户输入。

