

(19)



(11)

EP 3 111 871 B1

(12)

EUROPEAN PATENT SPECIFICATION

(45) Date of publication and mention of the grant of the patent:
28.03.2018 Bulletin 2018/13

(51) Int Cl.:
A61B 18/14^(2006.01) A61B 5/00^(2006.01)

(21) Application number: **16176559.9**

(22) Date of filing: **28.06.2016**

(54) CATHETER WITH STACKED SPINE ELECTRODE ASSEMBLY

KATHETER MIT GESTAPELTEN ELEKTRODENANORDNUNGEN

CATHÉTER AVEC ENSEMBLES D'ÉLECTRODES EMPILÉS

(84) Designated Contracting States:
AL AT BE BG CH CY CZ DE DK EE ES FI FR GB GR HR HU IE IS IT LI LT LU LV MC MK MT NL NO PL PT RO RS SE SI SK SM TR
Designated Extension States:
BA ME
Designated Validation States:
MA MD

(72) Inventors:
• **WU, Steven**
Irwindale, CA 91706 (US)
• **MIN, Sungwoo**
Irwindale, CA 91706 (US)

(30) Priority: **29.06.2015 US 201514754566**

(74) Representative: **Carpmaels & Ransford LLP**
One Southampton Row
London WC1B 5HA (GB)

(43) Date of publication of application:
04.01.2017 Bulletin 2017/01

(56) References cited:
EP-A1- 2 752 153 US-A1- 2012 271 302
US-A1- 2014 350 564 US-A1- 2015 141 785

(73) Proprietor: **Biosense Webster (Israel) Ltd.**
2066717 Yokneam (IL)

EP 3 111 871 B1

Note: Within nine months of the publication of the mention of the grant of the European patent in the European Patent Bulletin, any person may give notice to the European Patent Office of opposition to that patent, in accordance with the Implementing Regulations. Notice of opposition shall not be deemed to have been filed until the opposition fee has been paid. (Art. 99(1) European Patent Convention).

Description

FIELD OF INVENTION

[0001] This invention relates to catheters, in particular, intravascular catheters for tissue diagnostics and ablation.

BACKGROUND

[0002] Cardiac arrhythmia, such as atrial fibrillation, occurs when regions of cardiac tissue abnormally conduct electric signals to adjacent tissue, thereby disrupting the normal cardiac cycle and causing asynchronous rhythm. Important sources of undesired signals are located in the tissue region, for example, one of the atria or one of the ventricles. Regardless of the sources, unwanted signals are conducted elsewhere through heart tissue where they can initiate or continue arrhythmia.

[0003] Procedures for treating arrhythmia include surgically disrupting the origin of the signals causing the arrhythmia, as well as disrupting the conducting pathway for such signals. More recently, it has been found that by mapping the electrical properties of the endocardium and the heart volume, and selectively ablating cardiac tissue by application of energy, it is possible to cease or modify the propagation of unwanted electrical signals from one portion of the heart to another. The ablation process destroys the unwanted electrical pathways by formation of non-conducting lesions.

[0004] In this two-step procedure--mapping followed by ablation--electrical activity at points in the heart is typically sensed and measured by advancing a catheter containing one or more electrical sensors into the heart, and acquiring data at a multiplicity of points. These data are then utilized to select the target areas at which ablation is to be performed.

[0005] For greater mapping resolution, it is desirable for a mapping catheter to provide very high density signal maps through the use of a multitude of electrodes sensing electrical activity within a small area, for example, about a square centimeter. For mapping within an atria or a ventricle (for example, an apex of a ventricle), it is desirable for a catheter to collect larger amounts of data signals within shorter time spans. It is also desirable for such a catheter to be adaptable to different tissue surfaces, for example, flat, curved, irregular or nonplanar surface tissue, yet remain in a predetermined configuration where electrode spatial relationships are generally maintained during sensing and mapping. Moreover, with the need for greater electrode density, it is desirable for the catheter to accommodate additional electrode support structures in a manner that allows for more complex electrode arrays with improved tissue contact and manufacturability.

[0006] EP2752153 discusses a catheter having first and second distal assemblies. Each distal assembly comprises a plurality of spines, and each spine carries

at least one electrode.

SUMMARY OF THE INVENTION

[0007] The catheter of the present invention provides a distal electrode assembly or array that has a more simplistic construction for improved manufacturability and yet is able to accommodate complex electrode arrays for greater electrode density and tissue contact. The catheter includes an electrode array comprising a mounting member with a lumen and one or more spine supports, with each spine support including a base having a planar configuration, and a plurality of spines extending from the base, wherein each base occupies in a different plane in the lumen.

[0008] With a planar configuration, each base is advantageously positioned in the mounting member or stem in a "stacked" configuration where each base occupies a different plane in the lumen of the stem. For example, the "stacked" configuration may include a "storied" (or "multi-storied") configuration, where each occupies a different plane in the lumen of the mounting stem. Depending on the volume of space available in the stem and the plurality of bases, the bases may be aligned and be separated by a space gap from adjacent bases, similar to floors of a multi-storied building wherein each floor occupies a different plane and is separated by a space gap from adjacent floors.

[0009] In some embodiments, each spine includes a proximal portion and a distal portion, and the distal portions of the array extend in a common plane. The distal portions of the array may be linear. The distal portions may be parallel with each other. The common plane may be parallel with at least one of the planes occupied by the bases.

[0010] In some embodiments, each spine has a free distal end. In some embodiments, each spine has a distal end that is connected to at least one distal end of another spine.

[0011] The present invention is also directed to catheter comprising an elongated catheter body, and an electrode array, the array comprising a mounting stem and at least first and second spine supports, each spine support including a base having a planar configuration, and a plurality of spines extending from the base. The array also includes a nonconductive covering on each spine, and one or more electrodes carried on the spines. The first base is fixed in a lumen of the stem at a first plane and the second base is fixed in the lumen of the stem at a second plane different from the first plane.

[0012] The present invention is further directed to a catheter comprising an elongated catheter body, an electrode array distal of the catheter body, the array comprising a mounting stem, and at least first and second spine supports, each spine support including a base having a planar configuration, and a plurality of spines extending from the base. The array also includes a nonconductive covering on each spine, and one or more electrodes car-

ried on the spines. The first base is fixed in a lumen of the stem at a first plane, the second base is fixed in the lumen of the stem at a second plane different from the first plane, and each spine has a distal linear portion, and the distal linear portions of the array are parallel with each other.

[0013] In some embodiments, the distal linear portions of the array are parallel with a longitudinal axis of the stem.

[0014] In some embodiments, the plurality of spines ranges between about two and six.

BRIEF DESCRIPTION OF THE DRAWINGS

[0015] These and other features and advantages of the present invention will be better understood by reference to the following detailed description when considered in conjunction with the accompanying drawings wherein:

FIG. 1 is a perspective view of a catheter of the present invention, in accordance with some embodiments.

FIG. 2A is a side cross-sectional view of the catheter of FIG. 1, including a junction between a catheter body and a deflection section, taken along a first diameter.

FIG. 2B is a side cross-sectional view of the catheter of FIG. 1, including the junction of FIG. 2A, taken along a second diameter generally perpendicular to the first diameter.

FIG. 2C is an end cross-sectional view of the deflection section of FIGS. 2A and 2B, taken along line C-C.

FIG. 3A is a side cross-sectional view of the catheter of FIG. 1, including a junction between the deflection section and a distal electrode assembly, taken along a first diameter.

FIG. 3B is a side cross-sectional view of the junction of FIG. 3A, taken along a second diameter generally perpendicular to the first diameter.

FIG. 3C is an end cross-sectional view of the deflection section of FIGS. 3A and 3B, taken along line C-C.

FIG. 3D is an end cross-sectional view of the junction of FIGS. 3A and 3B, taken along line D-D.

FIG. 4A is a perspective view of a junction between the deflection section and the distal electrode assembly, with parts broken away, in accordance with one embodiment.

FIG. 4B is an end cross-sectional view of a ring electrode mounted on a spine of FIG. 4A, taken along line B-B.

FIG. 5 is a partial perspective view of a spine support and a mounting stem, of FIG. 4A.

FIG. 6A is a detailed perspective view of the spine support and mounting stem of FIG. 5.

FIG. 6B is an end view of the spine support and mounting stem of 6A.

FIG. 7A is a perspective view of an irrigated ring electrode mounted on a spine, in accordance with one embodiment.

FIG. 7B is a side cross-sectional view of the irrigated ring electrode of FIG. 7A, taken along line A-A.

FIG. 7C is an end cross-sectional view of the irrigated ring electrode of FIG. 7B, taken along line B-B.

DETAILED DESCRIPTION OF THE INVENTION

[0016] As shown in FIG. 1, the catheter 10 comprises an elongated catheter body 12, an intermediate deflection section 14, a distal electrode assembly or array 15 with a plurality of spines, and a deflection control handle 16 attached to the proximal end of the catheter body 12. In accordance with a feature of the present invention, the distal electrode array 15 includes multiple spine supports that enable the spines to be mounted to the distal end of the catheter in a spatially efficient manner that accommodates more complex spine geometries while improving electrode-to-tissue contact and manufacturability of the catheter.

[0017] With reference to FIGS. 2A and 2B, the catheter body 12 comprises an elongated tubular construction having a single, axial or central lumen 18. The catheter body 12 is flexible, i.e., bendable, but substantially non-compressible along its length. The catheter body 12 can be of any suitable construction and made of any suitable material. In some embodiments, the catheter body 12 comprises an outer wall 20 made of polyurethane or PEBAX. The outer wall 20 comprises an imbedded braided mesh of stainless steel or the like to increase torsional stiffness of the catheter body 12 so that, when the control handle 16 is rotated, the intermediate section 14 of the catheter 10 rotates in a corresponding manner.

[0018] The outer diameter of the catheter body 12 is not critical. Likewise, the thickness of the outer wall 20 is not critical, but is thin enough so that the central lumen 18 can accommodate a puller wire, one or more lead wires, and any other desired wires, cables or tubes. If desired, the inner surface of the outer wall 20 is lined with a stiffening tube 22 to provide improved torsional stability.

[0019] As shown in FIGS. 2A, 2B and 2C, the intermediate section 14 comprises a shorter section of tubing 19 having multiple lumens, for example, four off-axis lumens 31, 32, 33 and 34. The first lumen 31 carries a plurality of lead wires 40S for ring electrodes 37 mounted on the array 15. The second lumen 32 carries a first puller wire 24. The third lumen 33 carries a cable 36 for an electromagnetic position sensor 42 and a plurality of lead wires 40D and 40P for distal and proximal ring electrodes 38D and 38P carried on the catheter proximally of the distal electrode array 15. The fourth lumen 34 (for example, diametrically opposite of the second lumen 32 in the illustrated embodiment) carries a second puller wire 26. The tubing 19 is made of a suitable nontoxic material that is preferably more flexible than the catheter body 12. One suitable material for the tubing 19 is braided poly-

urethane, i.e., polyurethane with an embedded mesh of braided stainless steel or the like. The size of each lumen is not critical, but is sufficient to house the lead wires, puller wires, the cable and any other components.

[0020] The useful length of the catheter, i.e., that portion that can be inserted into the body excluding the distal electrode array 15, can vary as desired. Preferably the useful length ranges from about 110 cm to about 120 cm. The length of the intermediate section 14 is a relatively smaller portion of the useful length, and preferably ranges from about 3.5 cm to about 10 cm, more preferably from about 5 cm to about 6.5 cm.

[0021] A means for attaching the catheter body 12 to the intermediate section 14 is illustrated in FIGS. 2A and 2B. The proximal end of the intermediate section 14 comprises an outer circumferential notch 27 that receives the inner surface of the catheter body 12. The intermediate section 14 and catheter body 12 are attached by glue or the like.

[0022] If desired, a spacer (not shown) can be located within the catheter body between the distal end of the stiffening tube (if provided) and the proximal end of the intermediate section. The spacer provides a transition in flexibility at the junction of the catheter body and intermediate section, which allows this junction to bend smoothly without folding or kinking. A catheter having such a spacer is described in U.S. Pat. No. 5,964,757.

[0023] As shown in FIGS. 3A and 3B, the distal electrode array 15 includes a mounting member or stem 46 in the form of a short tubing mounted on a distal end of the tubing 19 of the intermediate deflection section 14. It is understood that the stem may be mounted onto the distal end of the catheter body 12 where the catheter includes no deflection section. The stem 46 has a central lumen 48 to house various components. The intermediate section 14 and stem 46 are attached by glue or the like. The stem 46 may be constructed of any suitable material, including nitinol.

[0024] As shown in FIG. 4A, the stem 46 houses various components, including, for example, the electromagnetic position sensor 42, and a distal anchor for the puller wires 24 and 26. In the disclosed embodiment, the distal anchor includes one or more washers, for example, a distal washer 50D and a proximal washer 50P, each of which has a plurality of matching axial through-holes that allow passage of components between the deflection section 14 and the stem 46 while maintaining axial alignment of these components relative to the longitudinal axis 95 of the catheter 10. As shown in FIG. 3D, the through-holes include holes 54 and 56 that are axially aligned with the second and fourth lumens 32 and 34 of the tubing 19, respectively, to receive a distal end of puller wires 24 and 26, respectively. It is understood that the puller wires 24 and 26 may actually form a single tensile member with a distal U-bend section that passes through the holes 54 and 56. With tension on the washers 50D and 50P exerted by the U-bend section of the puller wires 24 and 26, the washers firmly and fixedly abut against the distal

end of the tubing 19 of the deflection section 14 to distally anchor the U-bend section.

[0025] As shown in FIG. 3D, each washer also includes through-hole 58 which is axially aligned with the first lumen 31 and allows passage of the lead wires 40S from the deflection section 14 and into the lumen 48 of the stem 46. Each washer further includes through-hole 57 which is axially aligned with the third lumen 33 and allows passage of the sensor cable 36 from the deflection section 14 into lumen 48 of the stem 46 where the electromagnetic position sensor 42 is housed. The lead wire 40D also passes through the hole 57 to enter the lumen 48 for attachment to the distal ring electrode 38D carried on the outer surface of the stem 46 via an opening (not shown) formed in the side wall of the stem 46 through which a distal end of the lead wire 40D is welded or otherwise attached to the distal ring electrode 38D, as known in the art. Carried on the outer surface of the tubing 19 near the distal end of the intermediate deflection section 14, a proximal ring electrode 38P is connected to lead wire 40P via an opening 87 (FIG. 3B) formed in the side wall of the tubing 19 that provides communication between the third lumen 33 and outside of the tubing 19. The distal end of the lead wire is welded or otherwise attached to the proximal ring electrode 38P as known in the art.

[0026] With reference to FIGS. 4A, 5, 6A and 6B, multiple spine supports 21 are anchored in the lumen 48 near the distal end of the stem 46, with each support 21 having a base 23 and a plurality of spines 25 extending from a distal edge of the base 23. Each spine 25 has at least a proximal portion 25P and a distal portion 25D. The spines 25 may extend like fingers with free distal ends (see solid lines in FIG. 1), or the spines may have their distal ends connected forming closed loops (see broken lines in FIG. 1). With a planar configuration, each base 23 is advantageously positioned in the stem 46 in a "stacked" configuration where each base 23 occupies a different plane in the stem 46. For example, the "stacked" configuration may include a "storied" or "multi-storied" configuration, where each base 23 is aligned with each other, occupying a different plane in the stem 46. Depending on the volume of space available in the stem and the plurality of bases, the bases may be separated by a space gap from adjacent bases 23, similar to floors of a multi-storied building wherein each floor occupies a different plane and is separated by a space gap from adjacent floors. It is understood that the stem 46 may have any appropriate or desired cross-sectional shape, including, for example, circular, oval, rectangular and polygonal.

[0027] In the illustrated embodiment, the array 15 has a first spine support 21a and a second spine support 21b, where the bases 23a and 23b occupy or extend in planes Pa and Pb, respectively, and are separated by a distance d. As such, the spines 25a and 25b extending from the bases 23a and 23b have the freedom to extend in multiple different directions while the bases 23a and 23b occupy minimal space in the stem 46. Construction and manu-

facturability of the array 15 are also simplified by the stacking arrangement of the bases.

[0028] More complex array geometries may include the distal spine portions 25Da and 25Db all extending within a common plane Pc, despite their respective bases 23a and 23b being in different planes Pa and Pb within the stem 46 (see FIG. 5). For example, the planes Pa and Pb may be parallel or nonparallel to each other, as desired or appropriate, and the plane Pc may be coplanar with the plane Pa or with the plane Pb, or it may define a different plane from planes Pa and Pb (parallel or non-parallel with plane Pc).

[0029] It is understood, especially from FIGS. 6A and 6B, that the stem 46 can accommodate additional bases in its lumen 48 between the bases 23a and 23b, above the base 23a and/or below the base 23b to provide the array 15 with additional spines, as desired or appropriate. The bases 23 securely anchor the spines 15 within the stem 46, and greatly simplify the assembly and mounting of the array 15 onto the distal end of the catheter, whether the stem is mounted on a distal end of the deflection section 14, or of the catheter body 12 where the catheter has no deflection section 14.

[0030] As best shown in FIG. 6B, the proximal spine portions 25Pa may extend from its base 23a at different locations from the locations at which the proximal spine portions 25Pb may extend from its base 23b, so that the proximal spine portions 25Pa are laterally offset from the proximal spine portions 25Pb, even though the bases 23a and 23b are aligned.

[0031] In the illustrated embodiments, both of the proximal spine portions 25P and the distal spine portions are linear 25D, however, the proximal spine portions 25P diverge from the longitudinal axis of the stem 46, whereas the distal spine portions 25D are parallel with the longitudinal axis of the stem 46.

[0032] Each spine 25 has a nonconductive tubing or covering 64 along its length, as shown in FIG. 4A. On each spine 25, one or more ring electrodes 37 are mounted over the covering 64. Proximal of the array 15, the lead wires 40S for the ring electrodes 37 extend through a protective polytube 68. The lead wires 40S diverge near the distal end of the polytube 68, and extend toward their respective spine 25, into lumen 65 of the respective non-conductive covering 64. As shown in FIG. 4B, each lead wire 40S is connected to its respective ring electrode 37 via a respective opening 69 formed in the side wall of the covering 64 through which a distal end of the lead wire reaches outside of the covering 64 and is welded or otherwise attached to its ring electrode 37.

[0033] In other embodiments, irrigated ring electrodes 371 are carried on the spines 25, as shown in FIGS. 7A, 7B and 7C. Each spine 25 is covered by a respective multi-lumened tubing 80 having, for example, a first lumen 81 through which the spine extends, a second lumen 82 for lead wires 40S, and a third lumen 83 for passing irrigation fluid via a passage 88 formed in the sidewall of the tubing 80 to annular space gap G between outer wall

of the tubing 80 and side wall of the ring electrode 371 which are formed with fluid ports 85.

[0034] In some embodiments, the ring electrodes (irrigated or nonirrigated) are carried on the distal spine portions 25D. The plurality of ring electrodes on each spine may range between about 4 and 11, preferably about 6 and 9, and more preferably about 8. Depending on the plurality of spines, the distal electrode array 15 may carry a plurality of electrodes ranging between about 20 and 44, preferably between about 28 and 36 electrodes, and more preferably about 32 electrodes. In some embodiments, the electrode density is about 15 electrodes per square centimeter and dimensions of about 12mm x 18mm.

[0035] In some embodiments, the spine supports 23 and the stem 46 are made of a material having shape-memory, i.e., that can be temporarily straightened or bent out of its original shape upon exertion of a force and is capable of substantially returning to its original shape in the absence or removal of the force. One suitable material for the support member is a nickel/titanium alloy. Such alloys typically comprise about 55% nickel and 45% titanium, but may comprise from about 54% to about 57% nickel with the balance being titanium. A nickel/titanium alloy is nitinol, which has excellent shape memory, together with ductility, strength, corrosion resistance, electrical resistivity and temperature stability. The spine supports may be formed from a sheet material which is, for example, die cut or laser cut into the configuration of the base and the spines. Side edges of the bases 23 may be affixed to inner surface of the stem 46 by any suitable manner, e.g., laser welding, adhesives, or the like. The non-conductive coverings 64 or the tubings 80 surrounding the spines 25 can be made of any suitable material, and is preferably made of a biocompatible plastic such as polyurethane or PEBAX.

[0036] At the junction of distal electrode array 15 and the stem 46, the non-conductive covering 64 or the multi-lumened tubing 80 of each spine 25 may be attached and sealed at its proximal end to the stem 46 by the polyurethane or the like.

[0037] The proximal ends of the lead wires 40S, 40D and 40P for the spine loop ring electrodes 37, and for the distal and proximal ring electrodes 38D and 38P proximal of the array 15, respectively, are electrically connected to a suitable connector (not shown) in the distal end of the control handle 16, which is connected to a source of ablation energy, e.g., RF energy, as is known in the art. The lead wires 40S, 40D and 40P extend through the central lumen 18 of the catheter body 12 (FIG. 2B). The lead wires 40S extend through the first lumen 31 of the tubing 19 of the intermediate section 14, and the lead wires 40D and 40P extend through the third lumen 33 of the tubing 19 (FIGS. 2C and 3C). Passing through the holes 58 in the washers 50D and 50P, the lead wires 40S extend through the polytube 68 which protects them from being damaged by the hole 58 (FIG. 3D).

[0038] In the depicted embodiment, the lead wires 40S

extending through the central lumen 18 of the catheter body 12 and the first lumen 31 in the deflection section 14 may be enclosed within a protective sheath 94 to prevent contact with other components in the catheter. The protective sheath can be made of any suitable material, preferably polyimide. As would be recognized by one skilled in the art, the protective sheath can be eliminated if desired.

[0039] The ring electrodes 37, 371 and 38D and 38P are made of any suitable solid conductive material, such as platinum or gold, preferably a combination of platinum and iridium, and mounted onto the non-conductive cover 64 and the stem 46 with glue or the like. Alternatively, the ring electrodes can be formed by coating the non-conductive cover 64 and stem 46 with an electrically conducting material, like platinum, gold and/or iridium. The coating can be applied using sputtering, ion beam deposition or an equivalent technique.

[0040] In some embodiments, each ring electrode carried on the spines 25 is relatively short, having a length ranging from about 0.4 mm to about 0.75 mm. Moreover, the electrodes may be arranged in pairs, where two electrodes of a pair are spaced more closely to each other than they are to other pairs of electrodes. The closely-spaced electrode pairs allow for more accurate detection of near field pulmonary vein potential versus far field atrial signals, which is very useful when trying to treat atrial fibrillation. Specifically, the near field pulmonary vein potentials are very small signals whereas the atria, located very close to the pulmonary vein, provides much larger signals. Accordingly, even when the mapping array is placed in the region of a pulmonary vein, it can be difficult for the physician to determine whether the signal is a small, close potential (from the pulmonary vein) or a larger, farther potential (from the atria). Closely-spaced bipole electrodes permit the physician to more accurately determine whether he is looking at a close signal or a far signal. Accordingly, by having closely-spaced electrodes, one is able to target exactly the locations of myocardial tissue that have pulmonary vein potentials and therefore allows the clinician to deliver therapy to the specific tissue. Moreover, the closely-spaced electrodes allow the physician to determine the exact anatomical location of the ostium/ostia by the electrical signal.

[0041] In some embodiments, a proximal electromagnetic position sensor 42P is housed in the lumen 48 of the stem 46 (FIG. 4A). A sensor cable 36P extends from a proximal end of the position sensor 42P, and through the hole 57 of the washers 50 (FIG. 3D), the third lumen 33 of the tubing 19 of the deflection section 14 (FIG. 2C), and the central lumen 18 of the catheter body 12 (FIG. 2B). The cable 36P is attached to a PC board in the control handle 16, as known in the art. In some embodiments, one or more distal electromagnetic position sensors may be housed in the array, for example, in one or more distal portions of the array. Sensor cable(s) 36D may extend through the lumen 65 of spine covering 64 (FIG. 4B) or a fourth lumen 84 of the tubing 80 (FIG. 7C).

[0042] As shown in FIGS. 2A and 2C, the puller wires 24 and 26 (whether as two separate tensile members or parts of a single tensile member) are provided for bi-directional deflection of the intermediate section 14. The puller wires 24 and 26 are actuated by mechanisms in the control handle 16 that are responsive to a thumb control knob or a deflection control knob 11. Suitable control handles are disclosed in U.S. Patent Nos. 6,123,699; 6,171,277; 6,183,435; 6,183,463; 6,198,974; 6,210,407 and 6,267,746.

[0043] The puller wires 24 and 26 extend through the central lumen 18 of the catheter body 12 (FIG. 2A) and through the second and fourth lumens 32 and 34, respectively, of the tubing 19 of the deflection section 14 (FIG. 2C). As shown in FIGS. 3A and 3C, they extend through holes 54 and 56, respectively of the washers 50. Where the puller wires are part of a single tensile member, the single tensile member has a U-bend 24/26U (FIG. 3A) at the distal face of the distal washer 50D which anchors the distal ends of the puller wires. In that regard, the U-bend extends through a short protective tubing 70 to protect the puller wires from the holes 54 and 56. Alternatively, where the puller wires are separate tensile members, their distal ends may be anchored via T-bars, as known in the art and described in, for example, U.S. Patent No. 8,603,069. In any case, the puller wires 24 and 26 are made of any suitable metal, such as stainless steel or Nitinol, and each is preferably coated with TEFLON or the like. The coating imparts lubricity to the puller wires. The puller wires preferably have a diameter ranging from about 0.015 to about 0.025 cm (about 0.006 to about 0.010 inch).

[0044] A compression coil 66 is situated within the central lumen 18 of the catheter body 12 in surrounding relation to each puller wire 24, as shown in FIG. 2B. Each compression coil 66 extends from the proximal end of the catheter body 12 to the proximal end of the intermediate section 14. The compression coils 66 are made of any suitable metal, preferably stainless steel. Each compression coil 66 is tightly wound on itself to provide flexibility, i.e., bending, but to resist compression. The inner diameter of the compression coil 66 is preferably slightly larger than the diameter of its puller wire. The Teflon coating on each puller wire allows it to slide freely within its compression coil.

[0045] The compression coil 66 is anchored at its proximal end to the outer wall 20 of the catheter body 12 by a proximal glue joint (not shown) and at its distal end to the intermediate section 14 by a distal glue joint 92. Both glue joints may comprise polyurethane glue or the like. The glue may be applied by means of a syringe or the like through a hole made the sidewalls of the catheter body 12 and the tubing 19. Such a hole may be formed, for example, by a needle or the like that punctures the sidewalls which are heated sufficiently to form a permanent hole. The glue is then introduced through the hole to the outer surface of the compression coil 66 and wicks around the outer circumference to form a glue joint about

the entire circumference of the compression coil.

[0046] Within the second and fourth lumens 32 and 34 of the intermediate deflection section 14, each puller wire 24 and 26 extends through a plastic, preferably Teflon, puller wire sheath 39 (FIGS. 2A and 2C), which prevents the puller wires from cutting into the wall of the tubing 19 of the deflection section 14 when the deflection section 14 is deflected.

[0047] In some embodiments, the ring electrodes 38D and 38P proximal of the array 15 serve as reference electrodes for visualization of the catheter on a 3-D mapping system, such as CARTO.RTM 3 SYSTEM available from Biosense Webster, Inc., which automatically locates the EM sensor 42, processes reference location values from electrodes 38D and 38P, which are at a constant location from the EM sensor(s) and determines the location of the electrodes 37 and 371 and visualizes the remainder of the electrode array 15.

[0048] The preceding description has been presented with reference to presently preferred embodiments of the invention. Workers skilled in the art and technology to which this invention pertains will appreciate that alterations and changes in the described structure may be practiced without meaningfully departing from the principal and scope of this invention. As understood by one of ordinary skill in the art, the drawings are not necessarily to scale. Also, different features of different embodiments may be combined as needed or appropriate. Moreover, the catheters described herein may be configured to apply various energy forms, including microwave, laser, RF and/or cryogenes. Accordingly, the foregoing description should not be read as pertaining only to the precise structures described and illustrated in the accompanying drawings, but rather should be read consistent with and as support to the following claims which are to have their fullest and fair scope.

Claims

1. A catheter comprising:

an elongated catheter body (12);
 an electrode array (15) distal of the catheter body, the array comprising:

at least first and second spine supports (21), each spine support including a base (23) having a planar configuration, and a plurality of spines (25) extending from the base; and
 one or more electrodes (37) carried on the spines,

wherein the first base (23a) extends in a first plane (Pa) and the second base (23b) extends in a second plane (Pb) different from the first plane.

- 2. The catheter of claim 1, wherein the first (Pa) and second (Pb) planes are parallel, or are nonparallel.
- 3. The catheter of claim 1, wherein each spine (25) includes a proximal portion (25P) and a distal portion (25D), and the distal portions of the array extend in a common third plane (Pc).
- 4. The catheter of claim 3, wherein the third plane (Pc) is parallel with at least one of the first and second planes (Pa, Pb).
- 5. The catheter of claim 3, wherein the distal portions of the array (15) are linear.
- 6. The catheter of claim 5, wherein the distal portions of the array (15) are parallel with each other.
- 7. The catheter of claim 1, wherein the electrode array (15) includes a stem (46) having a lumen (48) in which the bases (23) of the at least first (23a) and second (23b) spine supports are fixed.
- 8. The catheter of claim 1, wherein each spine (25) has a free distal end.
- 9. The catheter of claim 1, wherein each spine (25) has a distal end that is connected to at least one distal end of another spine.
- 10. The catheter of any one of claims 1 to 6, wherein the electrode array (15) further comprises:
 - a mounting member (46) having a proximal end attached distally of the catheter body; and
 - a nonconductive covering (64) on each spine (25); and
 - wherein the first base (23a) is fixed in a lumen (48) of the mounting member (46) at the first plane (Pa) and the second base (23b) is fixed in the lumen (48) at the second plane (Pb).
- 11. The catheter of claim 10, wherein each spines (25) has a distal linear portion, and the distal linear portions of the array (15) are parallel with each other.
- 12. The catheter of claim 11, wherein the distal linear portions of the array (15) are parallel with a longitudinal axis of the mounting member (46).
- 13. The catheter of claim 11, wherein the plurality of spines (25) ranges between about two and six.

Patentansprüche

1. Katheter, umfassend:

einen langgestreckten Katheterkörper (12);
eine Elektrodengruppe (15) distal bezogen auf
den Katheterkörper, wobei die Gruppe umfasst:

wenigstens einen ersten und einen zweiten
Rückgratsträger (21), wobei jeder Rückgrat-
träger eine Basis (23) mit einer planaren
Konfiguration und eine Vielzahl von Rück-
graten (25), die von der Basis vorragen, um-
fasst; und
eine oder mehrere Elektroden (37), die von
den Rückgraten getragen werden,

wobei die erste Basis (23a) in einer ersten Ebene
(Pa) verläuft und die zweite Basis (23b) in einer
zweiten Ebene (Pb) verläuft, die von der ersten
Ebene verschieden ist.

2. Katheter gemäß Anspruch 1, wobei die erste (Pa)
und die zweite (Pb) Ebene parallel sind oder nicht
parallel sind. 20
3. Katheter gemäß Anspruch 1, wobei jedes Rückgrat
(25) einen proximalen Teil (25P) und einen distalen
Teil (25D) umfasst und die distalen Teile der Gruppe
in einer gemeinsamen dritten Ebene (Pc) verlaufen. 25
4. Katheter gemäß Anspruch 3, wobei die dritte Ebene
(Pc) parallel zu wenigstens einer von der ersten und
der zweiten Ebene (Pa, Pb) ist. 30
5. Katheter gemäß Anspruch 3, wobei die distalen Teile
der Gruppe (15) linear sind. 35
6. Katheter gemäß Anspruch 5, wobei die distalen Teile
der Gruppe (15) parallel zueinander sind. 35
7. Katheter gemäß Anspruch 1, wobei die Elektroden-
gruppe (15) einen Schaft (46) mit einem Lumen (48)
umfasst, in dem die Basen (23) der ersten (23a) und
zweiten (23b) Rückgratsträger befestigt sind. 40
8. Katheter gemäß Anspruch 1, wobei jedes Rückgrat
(25) ein freies distales Ende aufweist. 45
9. Katheter gemäß Anspruch 1, wobei jedes Rückgrat
(25) ein distales Ende aufweist, das mit wenigstens
einem distalen Ende eines anderen Rückgrats ver-
bunden ist. 50
10. Katheter gemäß Anspruch 1 bis 6, wobei die Elek-
trodengruppe (15) ferner umfasst:
ein Befestigungselement (46) mit einem proxi-
malen Ende, das distal bezogen auf den Kathete-
rkörper angebracht ist; und
und eine nichtleitende Abdeckung (64) an jedem
Rückgrat (25); und 55

wobei die erste Basis (23a) in einem Lumen (48)
des Befestigungselements (46) in der ersten
Ebene (Pa) fixiert ist und die zweite Basis (23b)
in dem Lumen (48) in der zweiten Ebene (Pb)
fixiert ist.

11. Katheter gemäß Anspruch 10, wobei jedes Rückgrat
(25) einen distalen linearen Teil aufweist und die dis-
talen linearen Teile der Gruppe (15) parallel zuein-
ander sind. 10
12. Katheter gemäß Anspruch 11, wobei die distalen li-
nearen Teile der Gruppe (15) parallel zu einer Längs-
achse des Befestigungselements (46) sind. 15
13. Katheter gemäß Anspruch 11, wobei die Vielzahl von
Rückgraten (25) in dem Bereich zwischen etwa zwei
und sechs liegt. 20

Revendications

1. Cathéter comprenant :

un corps de cathéter allongé (12) ;
un ensemble d'électrodes (15) en position dis-
tale du corps de cathéter, l'ensemble
comprenant :

au moins des premier et deuxième supports
à branches (21), chaque support à branche
comprenant une base (23) présentant une
configuration plane, et une pluralité de bran-
ches (25) s'étendant à partir de la base ; et
une ou plusieurs électrodes (37) suppor-
tées sur les branches,
la première base (23a) s'étendant dans un
premier plan (Pa) et la deuxième base (23b)
s'étendant dans un deuxième plan (Pb) dif-
férent du premier plan.

2. Cathéter selon la revendication 1, dans lequel les
premier (Pa) et deuxième (Pb) plans sont parallèles
ou sont non parallèles. 45
3. Cathéter selon la revendication 1, dans lequel cha-
que branche (25) comprend une partie proximale
(25P) et une partie distale (25D), et les parties dis-
tales de l'ensemble s'étendent dans un troisième
plan commun (Pc). 50
4. Cathéter selon la revendication 3, dans lequel le troi-
sième plan (Pc) est parallèle à au moins un des pre-
mier et deuxième plans (Pa, Pb). 55
5. Cathéter selon la revendication 3, dans lequel les
parties distales de l'ensemble (15) sont linéaires.

6. Cathéter selon la revendication 5, dans lequel les parties distales de l'ensemble (15) sont parallèles les unes aux autres.
7. Cathéter selon la revendication 1, dans lequel l'ensemble d'électrodes (15) comprend une tige (46) comportant une lumière (48) dans laquelle sont fixées les bases (23) des au moins premier (23a) et deuxième (23b) supports à branches. 5
10
8. Cathéter selon la revendication 1, dans lequel chaque branche (25) comporte une extrémité distale libre.
9. Cathéter selon la revendication 1, dans lequel chaque branche (25) comporte une extrémité distale qui est raccordée à au moins une extrémité distale d'une autre branche. 15
10. Cathéter selon l'une quelconque des revendications 1 à 6, dans lequel l'ensemble d'électrodes (15) comprend en outre : 20
25
un élément d'assemblage (46) comportant une extrémité proximale fixée en position distale du corps de cathéter ; et
un revêtement non conducteur (64) sur chaque branche (25) ; et
la première base (23a) est fixée dans une lumière (48) de l'élément d'assemblage (46) au niveau du premier plan (Pa) et la deuxième base (23b) est fixée dans la lumière (48) au niveau du deuxième plan (Pb). 30
11. Cathéter selon la revendication 10, dans lequel chaque branche (25) comporte une partie distale linéaire, et les parties distales linéaires de l'ensemble (15) sont parallèles les unes aux autres. 35
12. Cathéter selon la revendication 11, dans lequel les parties distales linéaires de l'ensemble (15) sont parallèles à un axe longitudinal de l'élément d'assemblage (46). 40
13. Cathéter selon la revendication 11, dans lequel la pluralité de branches (25) compte entre environ deux et six branches. 45

50

55

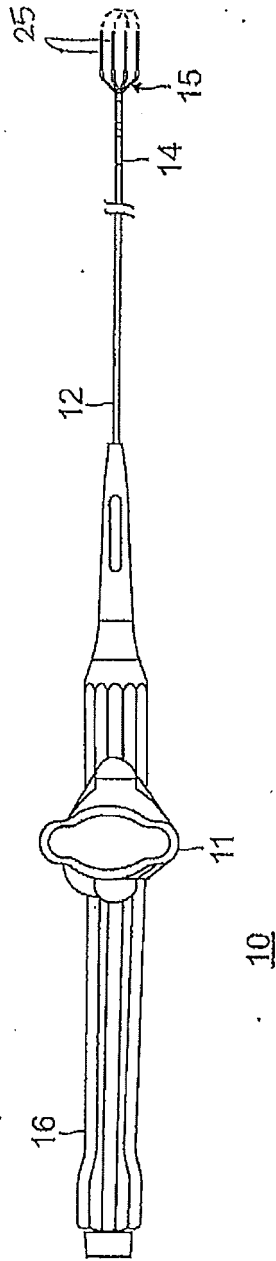
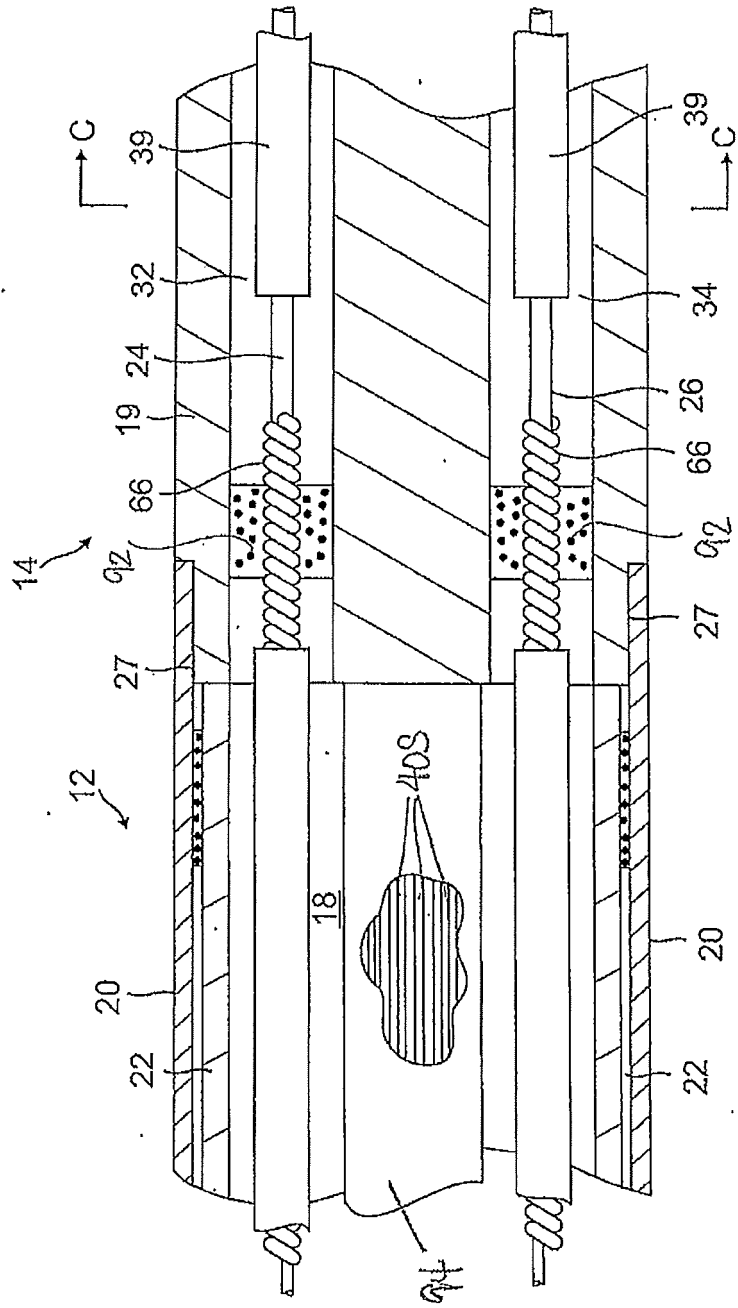

FIG. 1



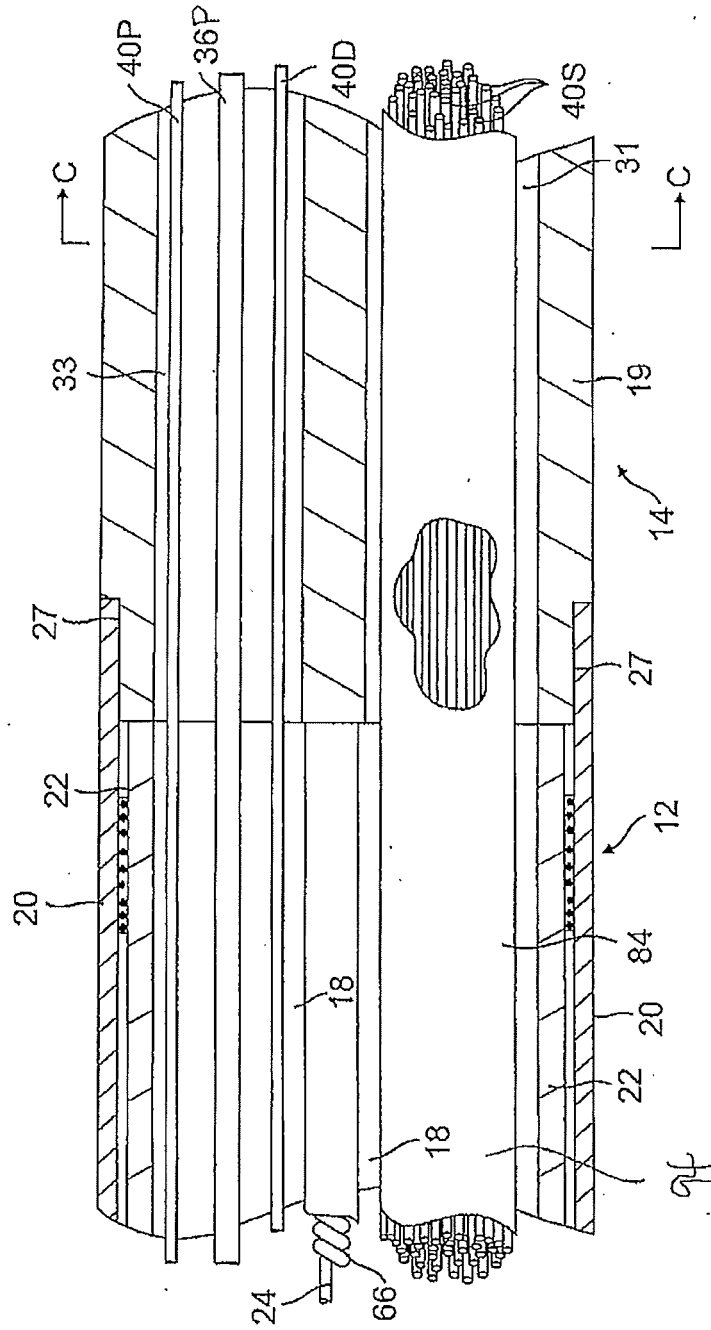

FIG. 2B

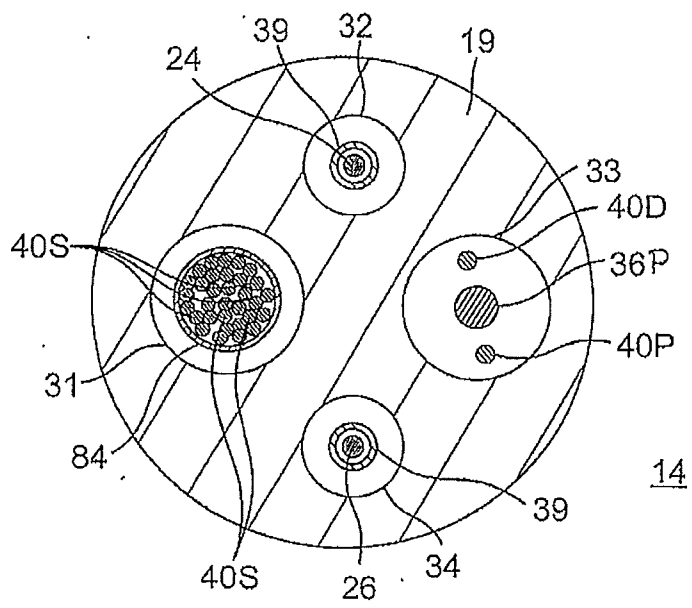

FIG. 2C

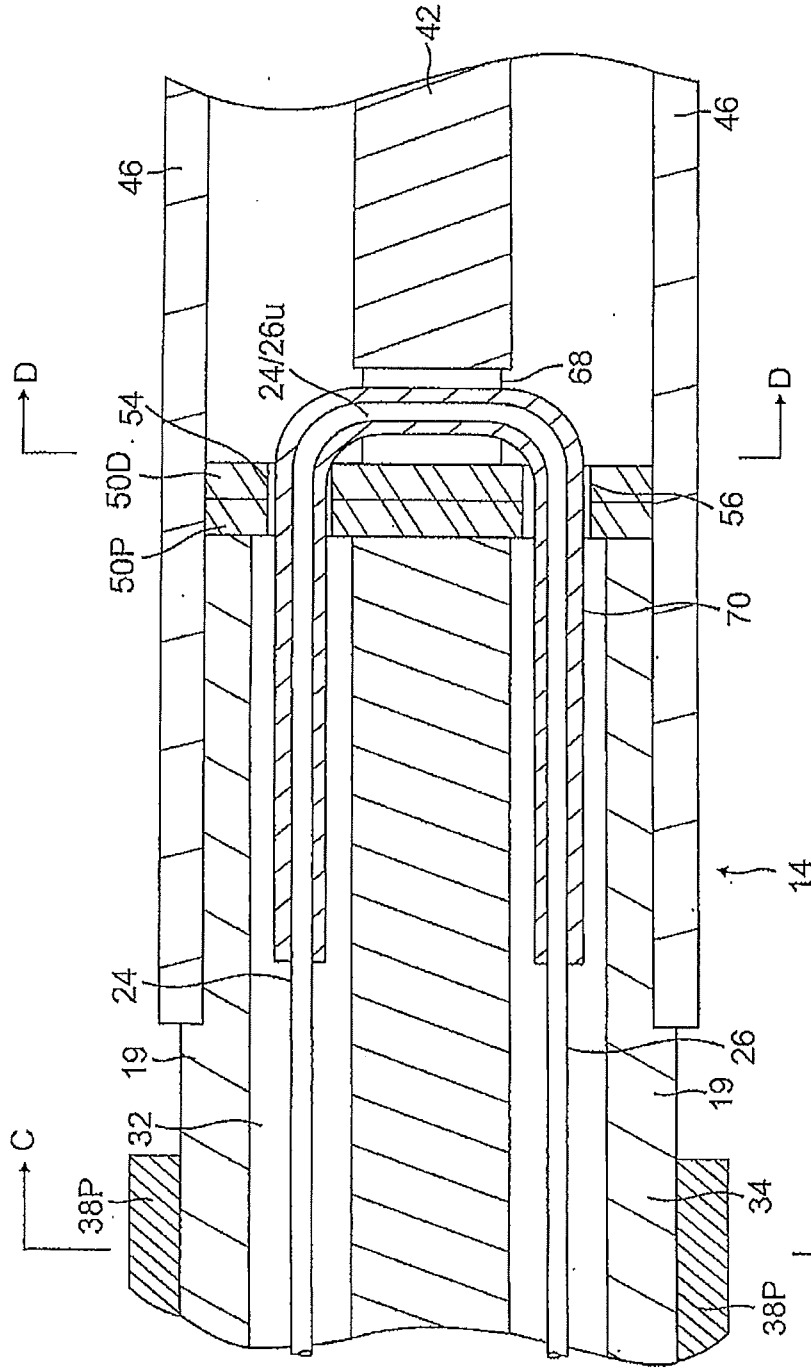

FIG. 3A

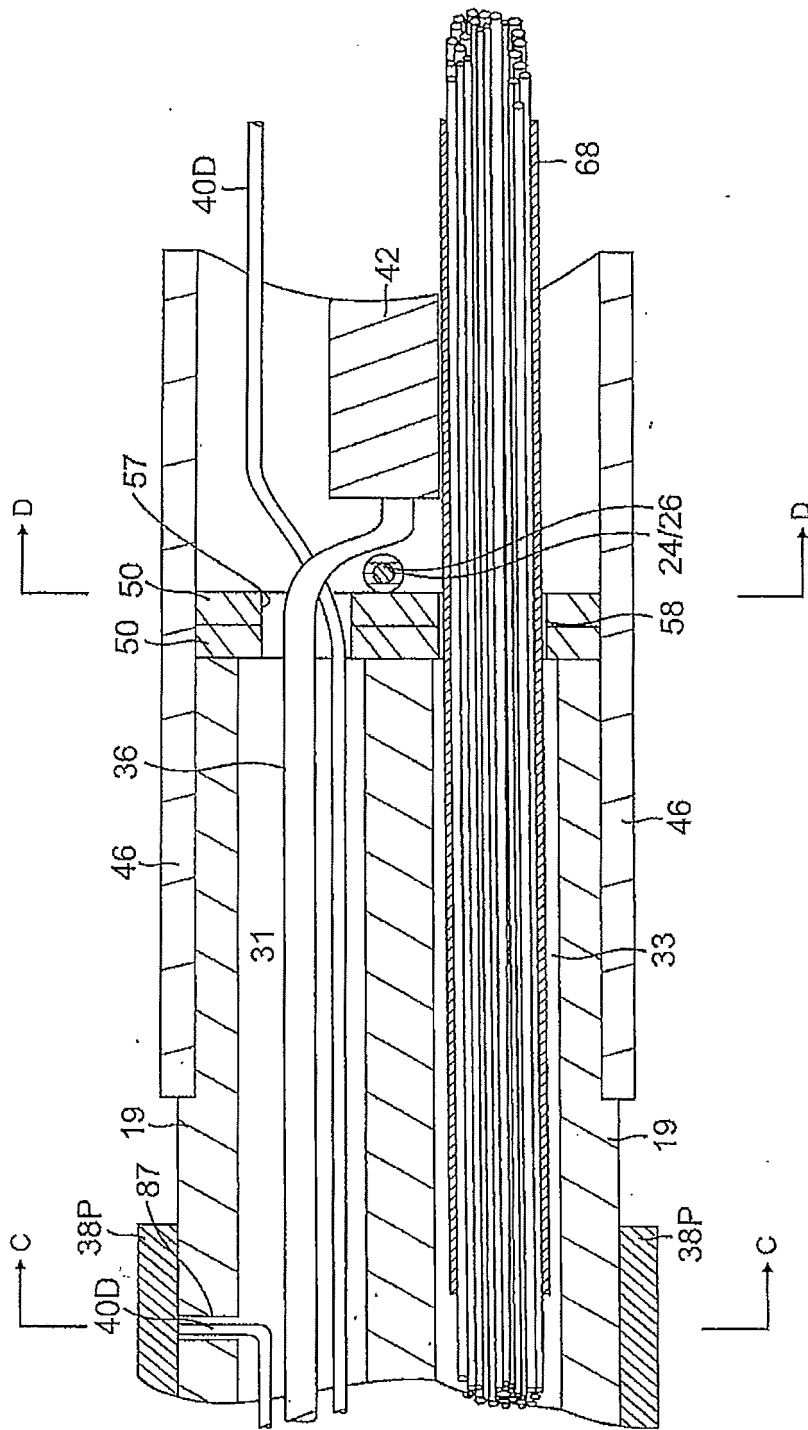

FIG. 3B

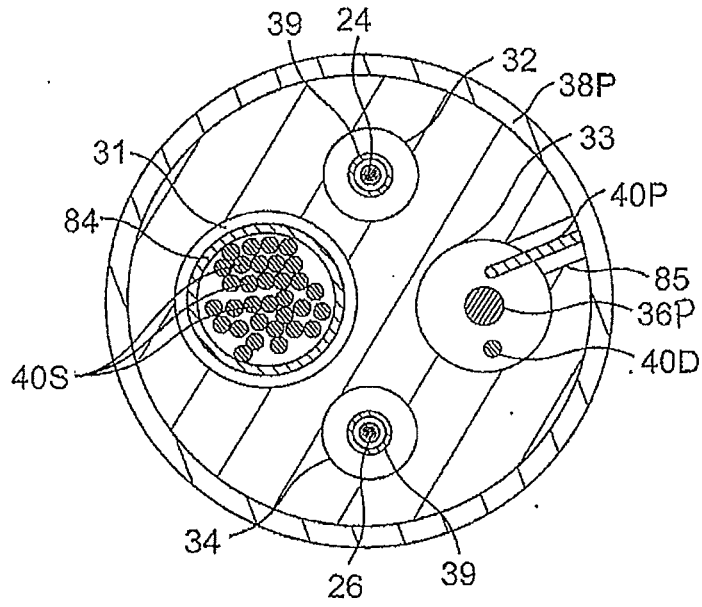

FIG. 3C

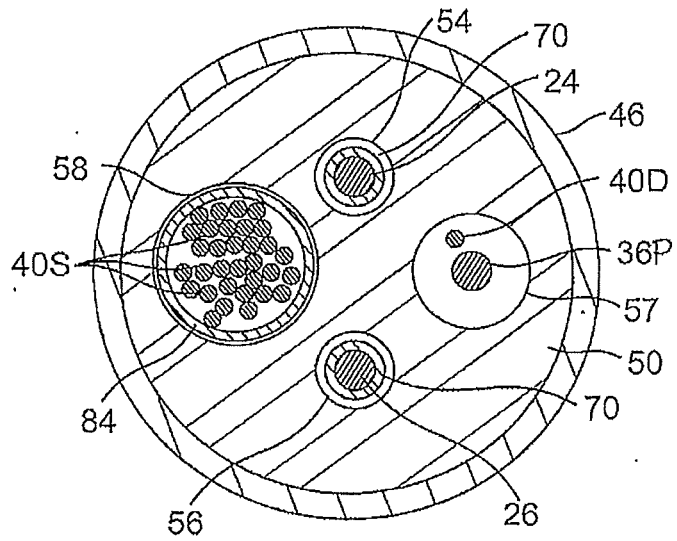
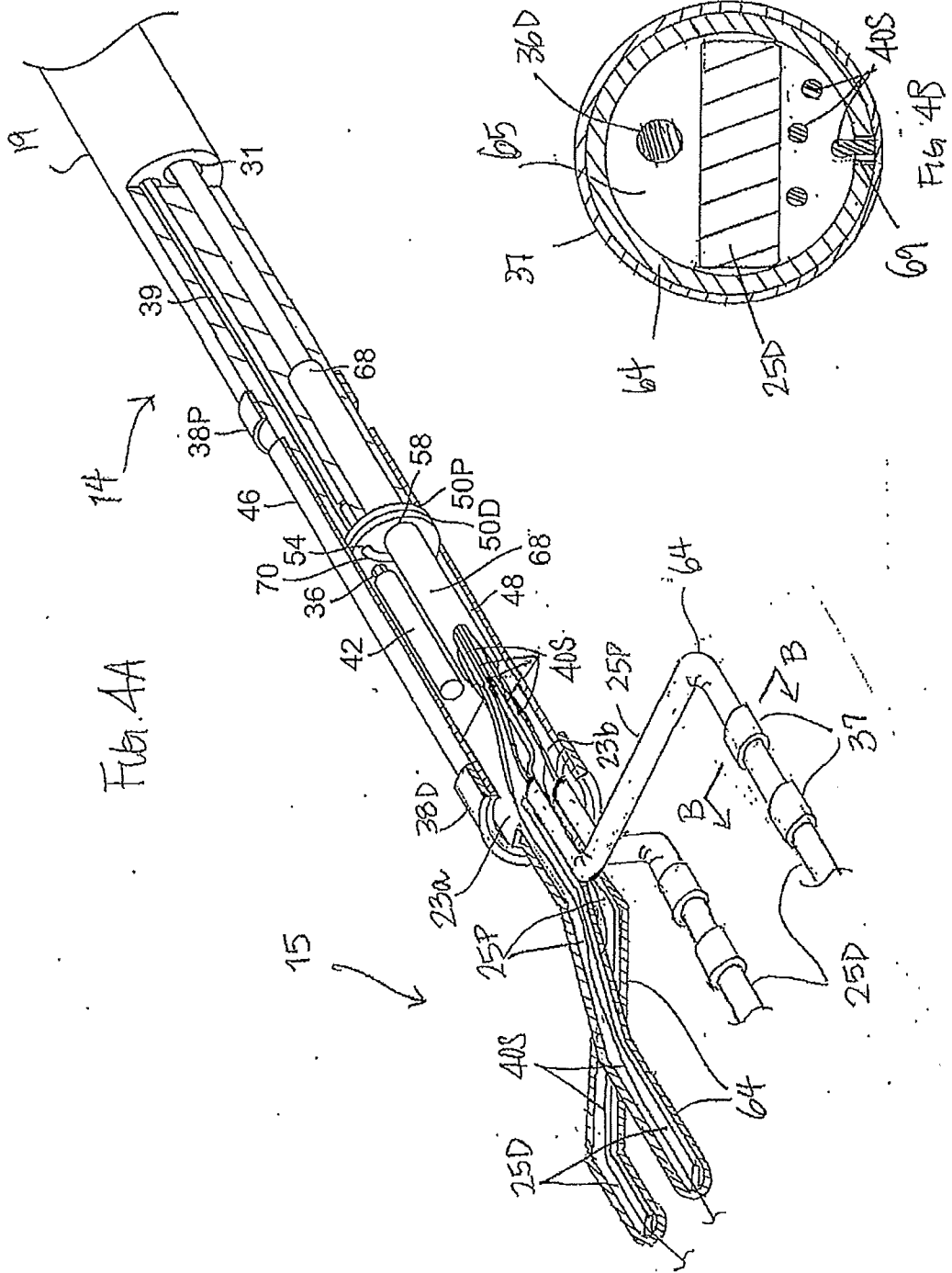

FIG. 3D



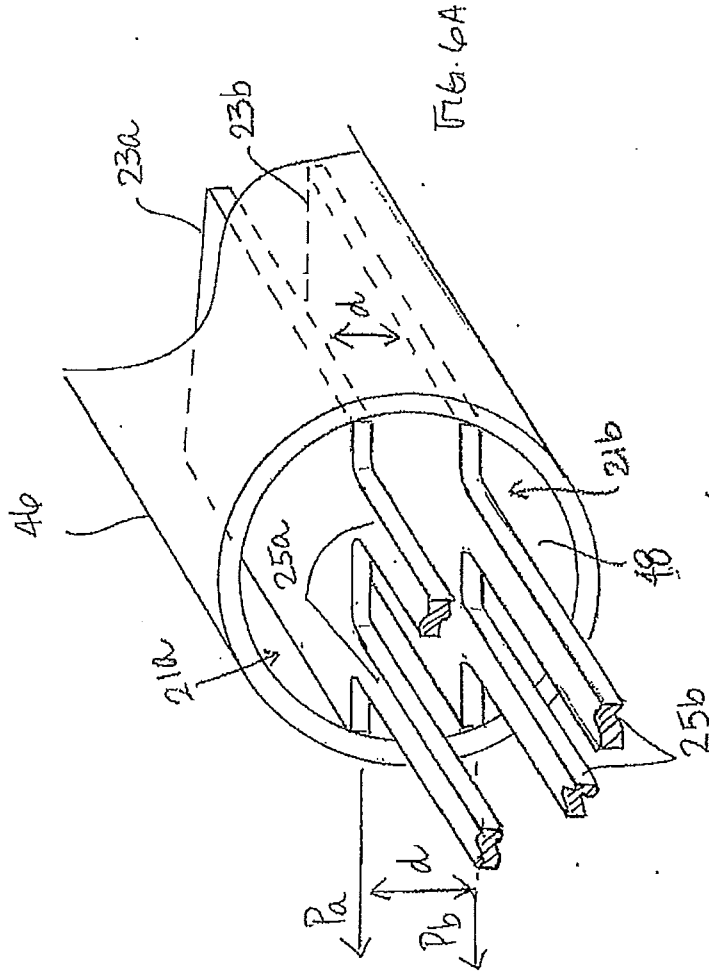

Fig. 6A

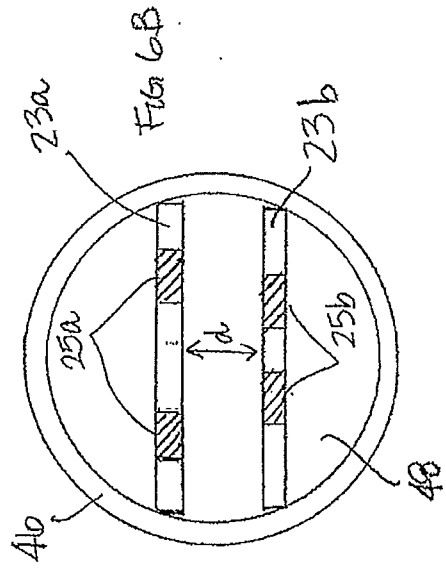
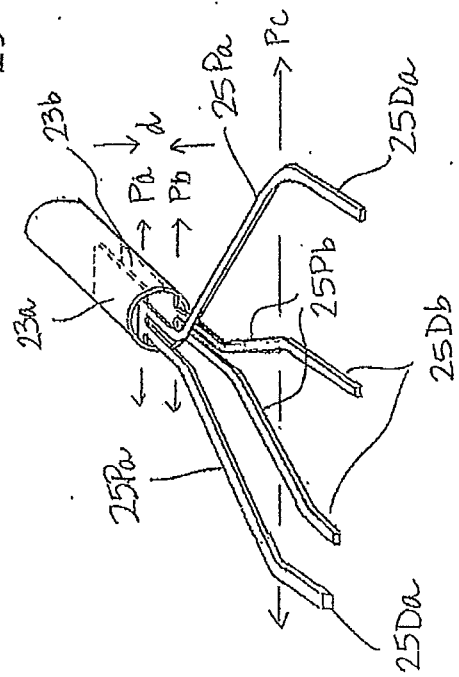
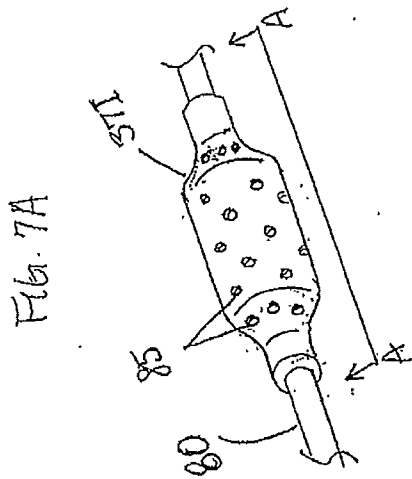
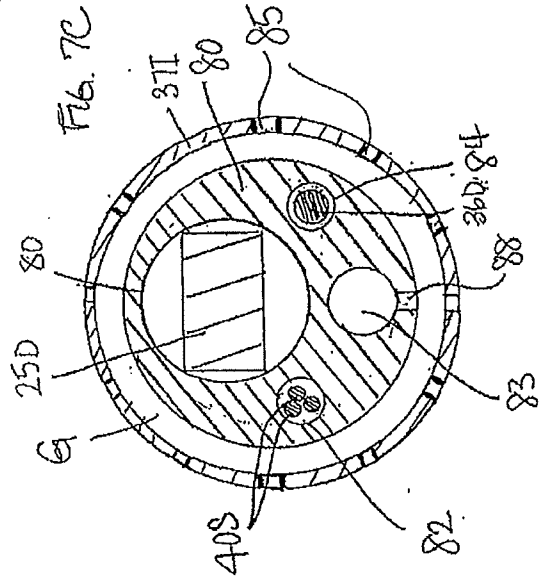
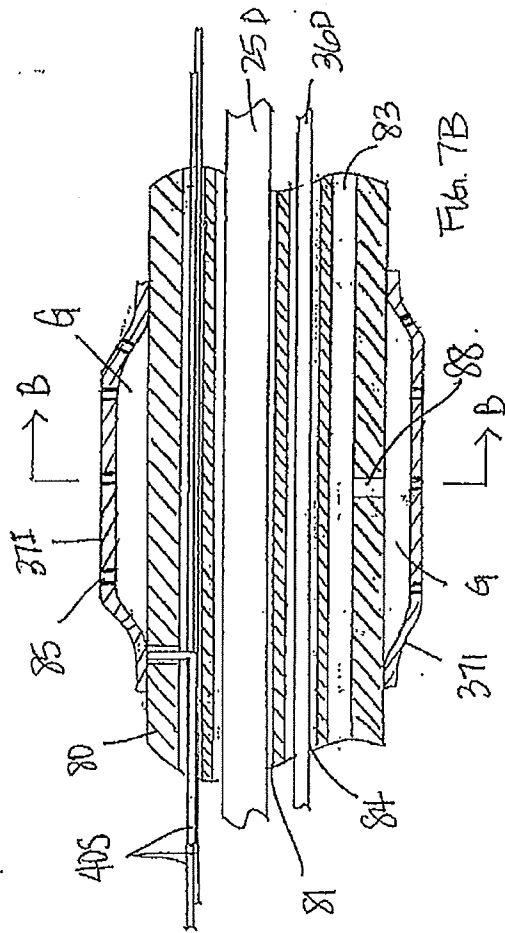

Fig. 6B

Fig. 5





REFERENCES CITED IN THE DESCRIPTION

This list of references cited by the applicant is for the reader's convenience only. It does not form part of the European patent document. Even though great care has been taken in compiling the references, errors or omissions cannot be excluded and the EPO disclaims all liability in this regard.

Patent documents cited in the description

- EP 2752153 A [0006]
- US 5964757 A [0022]
- US 6123699 A [0042]
- US 6171277 B [0042]
- US 6183435 B [0042]
- US 6183463 B [0042]
- US 6198974 B [0042]
- US 6210407 B [0042]
- US 6267746 B [0042]
- US 8603069 B [0043]

专利名称(译)	带有堆叠脊柱电极组件的导管		
公开(公告)号	EP3111871B1	公开(公告)日	2018-03-28
申请号	EP2016176559	申请日	2016-06-28
[标]申请(专利权)人(译)	韦伯斯特生物官能(以色列)有限公司		
申请(专利权)人(译)	生物传感韦伯斯特(以色列)LTD.		
当前申请(专利权)人(译)	生物传感韦伯斯特(以色列)LTD.		
[标]发明人	WU STEVEN MIN SUNGWO		
发明人	WU, STEVEN MIN, SUNGWO		
IPC分类号	A61B18/14 A61B5/00		
CPC分类号	A61B5/04 A61B5/0422 A61B18/12 A61B18/1492 A61B2018/00595 A61B2018/1467 A61B5/6859 A61B2018/0016 A61B2018/00267 A61B2018/00577 A61B5/6852 A61B18/00		
优先权	14/754566 2015-06-29 US		
其他公开文献	EP3111871A1		
外部链接	Espacenet		

摘要(译)

一种导管，包括细长导管主体，导管主体远侧的电极阵列，该阵列具有安装构件和至少第一和第二脊柱支撑件。每个脊柱支撑件包括具有平面构造的基部和从基部延伸的多个脊，其中第一基部在第一平面中延伸，第二基部在与安装构件中的第一平面不同的第二平面中延伸。

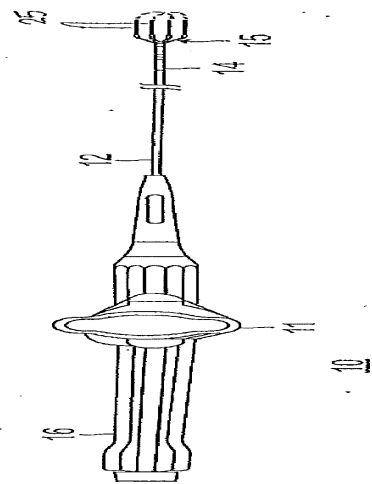

FIG. 1