



(11) **EP 2 736 587 B1**

(12) **EUROPEAN PATENT SPECIFICATION**

(45) Date of publication and mention of the grant of the patent:
03.10.2018 Bulletin 2018/40

(51) Int Cl.:
A61N 1/05 (2006.01) A61B 5/0478 (2006.01)
A61N 5/06 (2006.01) A61B 5/04 (2006.01)
A61N 1/36 (2006.01) A61B 5/00 (2006.01)

(21) Application number: **12751636.7**

(86) International application number:
PCT/US2012/047994

(22) Date of filing: **24.07.2012**

(87) International publication number:
WO 2013/016347 (31.01.2013 Gazette 2013/05)

(54) **NEURAL DEVICE WITH MODULAR ELECTRODE ARRAY**

NEURONALE VORRICHTUNG MIT MODULARER ELEKTRODENANORDNUNG

DISPOSITIF NEURAL AVEC RANGÉE D'ÉLECTRODES MODULAIRES

(84) Designated Contracting States:
AL AT BE BG CH CY CZ DE DK EE ES FI FR GB GR HR HU IE IS IT LI LT LU LV MC MK MT NL NO PL PT RO RS SE SI SK SM TR

- **KONG, Kc**
Ann Arbor, MI 48108 (US)
- **HETKE, Jamille**
Brooklyn, MI 49230 (US)
- **ANDERSON, David**
Ann Arbor, MI 48105 (US)

(30) Priority: **25.07.2011 US 201161511343 P**

(43) Date of publication of application:
04.06.2014 Bulletin 2014/23

(74) Representative: **Garratt, Peter Douglas et al**
Mathys & Squire LLP
The Shard
32 London Bridge Street
London SE1 9SG (GB)

(73) Proprietor: **NeuroNexus Technologies, Inc.**
Ann Arbor, MI 48108 (US)

(72) Inventors:

- **KIPKE, Daryl R.**
Dexter, MI 48130 (US)
- **VETTER, Rio J.**
Ypsilanti, MI 48197 (US)

(56) References cited:
WO-A1-2010/055421 WO-A1-2011/067297
WO-A2-2005/058145 WO-A2-2011/057276
US-A1- 2005 154 435 US-A1- 2010 198 297

EP 2 736 587 B1

Note: Within nine months of the publication of the mention of the grant of the European patent in the European Patent Bulletin, any person may give notice to the European Patent Office of opposition to that patent, in accordance with the Implementing Regulations. Notice of opposition shall not be deemed to have been filed until the opposition fee has been paid. (Art. 99(1) European Patent Convention).

Description

TECHNICAL FIELD

[0001] This invention relates generally to the neural devices field, and more specifically to an improved neural device with modular electrode array in the neurotechnology field.

BACKGROUND

[0002] Surface neural recording and stimulation involves placing an electrode array directly on the surface of the targeted neural tissue. The electrode array typically includes electrode sites that sense electrical activity in the tissue and can be used to assess neuronal activity. The electrode sites can also deliver small electrical currents to the tissue and can be used to stimulate neuronal activity. For example, electrocorticography, or ECoG, involves placing an electrode array directly on the cerebral cortex, the outer surface of the brain. ECoG can be used in epilepsy mapping procedures conducted to identify and locate diseased tissue in preparation for surgical resection of the diseased tissue. However, conventional surface arrays are large and have a limited spatial resolution that reduces the precision of sensed electrical activity or stimulated electrical activity, resulting in reduced precision of gathered neural activity information or activation. Thus, there is a need in the neural devices field to create an improved neural device with modular electrode arrays. This invention provides such an improved neural device.

[0003] Reference is directed to US 2010/0198297 which discloses subdural arrays that transmit electrocorticogram recordings wirelessly, across the patient's skull, allowing the craniotomy used for surgical placement of the arrays to be completely closed. In various embodiments, the arrays also respond to commands, applying signal patterns to the patient's brain for diagnostic and treatment purposes.

[0004] Reference is further directed to US 2005/0154435 which discloses apparatus that may be configured for placement at one or more cortical and/or neuroanatomical sites to provide electrical stimulation and/or monitor neuroelectric activity within a patient. An implantable articulated electrode assembly may include an array of electrodes or electrical contacts carried by a support member configured to be implanted or positioned relative to a set of neuroanatomical sites. Various embodiments of the articulated electrode assemblies may comprise multiple portions, segments, paddles, and/or panels having spatially divergent placement capabilities in relation to one another. Such segments or panels may be positioned in a variety of manners relative to each other and/or one or more neuroanatomical sites or locations, which may facilitate establishment of an intended type of stimulation field distribution and/or monitoring configuration.

[0005] Reference is further directed to WO 2011/067297 which discloses microelectrode array devices, and methods of fabrication and use of the same, to provide highly localized and efficient electrical stimulation of a neurological target. The device includes multiple microelectrode elements arranged along a supportive backing layer. The microelectrode elements are dimensional and shaped so as to target individual neurons, groups of neurons, and neural tissue as may be located in an animal nervous system, such as along a region of a cortex of a human brain. Beneficially, the neurological probe can be used to facilitate location of the neurological target and remain implanted for long-term monitoring and/or stimulation.

[0006] Reference is further directed to WO 2010/055421 which discloses microelectrode array devices, and methods of fabrication and use of the same, to provide highly localized and efficient stimulation of a neurological target. The device includes multiple microelectrode elements arranged along an elongated probe shaft. The microelectrode elements are dimensioned and shaped so as to target individual neurons, groups of neurons, and neural tissue as may be located in an animal nervous system, such as deep within a human brain. Beneficially, the neurological probe can be used to facilitate location of the neurological target and remain implanted for long-term monitoring and/or stimulation.

[0007] Reference is further directed to WO 2005/058145 which discloses an electrode device for taking a plurality of EEG measurements, and an associated method of taking EEG measurements, whereby a plurality of electrode contact-points atop a support member are in electrical communication with, and in relative proximity to, an integrated circuit converter circuitry. The integrated circuit/circuitry (IC) may be supported by the support member or by a lead assembly having wiring for the digital signal transmission. The support member may have a plurality of layers and be generally flexible, as fabricated of any of a number of flexible, generally insulative biocompatible materials to which circuitry may be etched or deposited, exhibiting sufficient structural integrity to decrease likelihood of degradation during surgery or once implanted. The IC may further comprise circuitry for digital filtering and signal analysis of the digital signals.

[0008] Reference is further directed to WO 2011/057276 which discloses a hybrid optical-electrical neural interface. The neural interface can include an array having a plurality of micro-optrodes (HO). The micro-optrodes are capable of optical and electrical stimulation and recording, allowing bidirectional communication with neurotissue. At least a portion of the plurality of micro-optrodes are independently optically addressable and include an optical waveguide along each micro-optrode (HO). Combining optical stimulation with electrical recording can allow artifact-free recording from nearby electrodes and in some cases even the same electrode, which is difficult to achieve with combined electrical recording and stimulation. The optical waveguide is con-

figured to direct light towards a distal end of the micro-optrode, allowing focal stimulation and recording. Penetrating micro-optrodes can allow access to deep tissue, while non-penetrating micro-optrodes can be used for extraneural stimulation.

SUMMARY OF THE INVENTION

[0009] The invention provides an apparatus according to claim 1 and a method according to claim 10. Preferred embodiments are defined in the dependent claims. Examples, embodiments and aspects disclosed herein, but not falling under the scope of claim 1 or 10, do not form part of the invention.

BRIEF DESCRIPTION OF THE FIGURES

[0010]

FIGURE 1 is a schematic of an example of a neural device, consistent with some example embodiments of the invention.

FIGURE 2 is a detailed schematic of an example of an electrode module in the modular electrode array in a neural device, consistent with some example embodiments of the invention.

FIGURES 3A and 3B show a comparison of the microelectrode distribution between a conventional ECoG device and an example of a neural device consistent with some example embodiments of the invention, respectively.

FIGURE 4 is a schematic of an example of a neural device, consistent with some example embodiments of the invention.

FIGURE 5 shows a block diagram of portions of an example of an electronic subsystem.

FIGURES 6A-6C is an illustration of an example of multi-scale functionality of a neural device consistent with some example embodiments of the invention.

FIGURES 7A and 7B show detailed schematics of examples of interconnects in a neural device of a preferred embodiment;

FIGURE 8 is a schematic of an example of coiled interconnects in a neural device, consistent with some example embodiments of the invention.

FIGURE 9 shows a flow diagram of an example of method of manufacturing a neural device.

FIGURES 10A-D and 11A-C illustrate an example of a method of manufacturing and assembling a neural device, consistent with some example embodiments of the invention.

DETAILED DESCRIPTION

[0011] The following description of example embodiments of the invention is not intended to limit the invention to these embodiments, but rather to enable any person skilled in the art to make and use this invention.

[0012] FIGURE 1 shows an example of a neural device 100. The neural device 100 includes modular electrode array. The modular electrode array includes a modular flexible substrate. The modular flexible substrate includes a plurality of electrode modules 110. An electrode module 110 can be planar and can include a plurality of electrodes 115. The electrodes 115 may be configured to sense a neural signal at a neural source or deliver neural stimulation energy to a neural target. As is described herein, multiple signals can be sensed by a group or subset of the electrodes to form a composite signal. The group of electrodes used in sensing the composite signal can be called a macroelectrode and the individual electrodes can be called microelectrodes. The electrodes 115 can be called microelectrodes because of their small size. The modular flexible substrate can include a spatial separation between the electrode modules 110. The modular electrode array also includes conductive interconnect 120 (e.g., conductive traces or wires) coupled to the plurality of microelectrodes. The conductive interconnect 120 may be used to one or both of route electrical signals sensed by the electrodes and route stimulus signals to the electrodes. The interconnect 120 can be used to carry signals between modules or to carry signals between the modular electrode array and a device separate from the neural device 100. The modular flexible substrate may be supported by a backing 170 of flexible material, such as silicone or another flexible polymer.

[0013] FIGURE 2 shows an example of an electrode module 210 that is planar. The electrode module 210 can include an array of microelectrodes 215 and can include one or more apertures 230. The apertures 230 may have different shapes, such as slots or circles as shown in the example. In some variations, the electrode module 210 may be preformed to have a particular curvature in order to conform to known anatomy of the target tissue. The electrode module 210 can be a flexible thin-film microfabricated structure, such as a polymer substrate. The polymer substrate may be parylene or polyimide, but may additionally and/or alternatively include any suitable material. Layers of materials can be deposited on the substrate and patterned through microfabrication processes such as those used in manufacture of semiconductors. The flexible thin-film microfabricated structure may be supported by a backing of flexible material. However, the module may be made in any suitable manner.

[0014] The microelectrodes 215 can be arranged in a microelectrode array of an approximately rectangular grid, although the microelectrodes 215 may include any number of microelectrodes 215 arranged in any suitable regular or irregular pattern. The microelectrode array can include recording electrodes that each provide a neural signal in a respective input channel, but additionally and/or alternatively may include stimulation or other kind of electrodes. In certain variations the microelectrodes 215 can be elliptical. In certain variations, the microelectrodes 215 can be approximately circular, but the micro-

electrodes 215 may be any suitable shape. In some examples, the electrode module 210 includes an array of microelectrodes that are substantially identical in size and shape. In some examples, the electrode module 210 includes an array of microelectrodes that differ in one or both of shape and size. In an illustrative non-limiting example, an electrode module 210 includes two substantially similar halves connected to each other. Each half including 32 microelectrodes (arranged in a 4 x 8 grid), such that each electrode module includes a total of 64 microelectrodes (arranged in an 8 x 8 grid) providing 64 channels of signal. The connected halves can be supported by a 1 mm thick silicone backing.

[0015] The apertures 230 of the electrode module 210 may allow passage of a penetrating electrode (e.g. elongated electrode shank) to be placed within the tissue. In some examples, one or more penetrating electrodes are included in the flexible substrate. In some examples, a penetrating electrode includes a microelectrode array attached to a carrier, such as an insulated wire. The apertures 230 may allow release of brain fluid or other fluid from the tissue, and/or increase mechanical flexibility of the module. As shown in FIGURE 2, the apertures 230 may be elliptical holes (e.g. circular apertures to permit defined placement of cylindrical penetrating electrodes), slots, or any suitable shape, such as a custom shape configured to permit passage of a particular instrument through the module. The neural device may include one or more waveguides (e.g., an optical fiber) that delivers light to at least a portion of the one or more apertures. In some variations, the apertures may form a series of ribs that increase the flexibility of a particular portion of the module. The apertures 230 may be interspersed between the microelectrodes 215 in a regular pattern. Alternatively, the electrode module 210 may not define any apertures and/or separate halves or other portions.

[0016] Multiple electrode modules can be combined to form the modular electrode array. The electrode modules may be combined to form a rectangular grid. The resulting rectangular grid can include microelectrodes that are distributed in a regular fashion within the rectangular grid. For example, as shown in FIGURE 1, the modular electrode array includes 16 electrode modules arranged in four columns of four modules each. Each electrode module shown includes two connected portions including a total of 64 microelectrodes, such that the modular electrode array includes 1024 microelectrodes arranged in a regular 32 x 32 grid and providing 1024 channels of signal. In an alternative arrangement providing a similar layout of 1024 microelectrodes, the modular electrode array may include 32 modules arranged in an 8 x 4 grid, where each module includes 32 microelectrodes.

[0017] FIGURES 3A and 3B illustrate a comparison of conventional electrode spacing (FIGURE 3A) and spacing using microelectrodes (FIGURE 3B). The spacing shown is for illustration purposes and is not meant to represent actual spacing of an actual device. In a non-limiting example, the diameter of a microelectrode can

be 0.575 millimeters (mm) and pitch between microelectrodes can be 2.5mm. The microelectrodes and the corresponding conductive traces coupled to the microelectrodes can be fabricated using microfabrication techniques to achieve the required spacing. Comparison of the FIGURES shows that an ECoG device having an array of 1024 microelectrodes takes up substantially the same area as an array of 64 conventional electrodes. Thus, an ECoG device having an array of microelectrodes includes more electrodes and conductive channels than a conventional 64-channel ECoG device.

[0018] FIGURE 4 shows an example of a system 400 that includes a neural device. The neural device includes a modular electrode array. The modular electrode array includes a modular flexible substrate that includes a plurality of electrode modules with a spatial separation between the electrode modules. A flexible backing 470 may support the modular flexible substrate. The electrode modules include electrodes and the modular electrode array includes conductive interconnect coupled to the electrodes. The system 400 also includes a plurality of electrically conductive leads 435 and an electronic subsystem 440 coupled to the electrically conductive leads 435 and the conductive interconnect of the modular electrode array. In some examples, the conductive interconnect includes conductive traces 420 arranged to extend between the modular electrode array and the electronic subsystem 440. In some examples, the number of electrical leads is less than the number of conductive traces. The electronic subsystem can include a multiplexer circuit to selectively transfer signals sensed by a subset of the plurality of conductive traces to one or more of the electrically conductive leads.

[0019] FIGURE 5 shows a block diagram of an example of an electronic subsystem 540. The electronic subsystem 540 includes a multiplexer circuit 545 having signal inputs, select inputs, and one or more signal outputs. The signal inputs to the multiplexer circuit 545 can be electrically coupled to the conductive channels of the flexible substrate shown in FIGURE 4. The electronic subsystem 540 also includes a selector circuit 550 electrically coupled to the select inputs of the multiplexer circuit and configured to activate the select inputs to direct a signal from an input of the multiplexer circuit to an output of the multiplexer circuit 545. In some variations, the electronic subsystem can include a noise reduction circuit 555 (e.g., one or more filter circuits) to reduce signal noise.

[0020] Returning to FIGURE 4, the system 400 can include a recording system 460 electrically coupled to the plurality of electrically conductive leads. In certain examples, the recording system 460 includes a data acquisition system (DAQ) that can include one or more of an analog to digital converter (ADC), a processor, and a memory. Multiplexing by the electronic subsystem 440 can reduce the number of recording channels needed in the recording system. Reducing the number of channels may enable the modular electrode array to be operable

with a standard interface (e.g., conventional medical lead technologies having discrete wires). However, the electronic subsystem may interface with custom or other suitable lead systems. In some variations, the electronic subsystem may lack a multiplexer such that the number of conductive traces (input channels) is equal to the number of leads coupled to the recording system, and/or may include other suitable front-end electronics, such as signal processing or noise reduction. Alternatively, the neural device may lack an electronic subsystem, such that the conductive traces also function as leads that directly couple the modular electrode array to the recording system. In this alternative, the conductive traces may be coupled to more durable leads more suitable for use external to the body, such as a ribbon cable.

[0021] The modular electrode array of the neural device can include recording microelectrodes on the electrode modules that may be operable individually to record respective neural signals, and/or may be grouped in patterns of different sizes and/or shapes to emulate functionality of a macroelectrode. The neural device is selectively capable of sensing signals along a gradient of precision such that the user (e.g. neurologist) can "zoom" in on a particular area of tissue and sense from any number of the microelectrodes in a more precise manner, thereby gathering more detailed and "richer" information about the tissue. The neural device is also selectively capable of providing stimulation currents focused along a gradient of precision. The neural device can be used for electrocorticography (ECoG), such as in mapping brain tissue in an epileptic patient to more accurately and precisely identify and locate diseased tissue for surgical resection, or mapping cortical functions. In some embodiments, the neural device can be used for coverage of stimulation and/or recording of other tissue surfaces, such as those of the spinal cord, peripheral nerve, and/or muscle. However, the neural device may be used for any suitable neural recording and/or stimulation applications. In certain variations, the neural device uses the electrodes for impedance measurements, such as by using a first set of electrodes for applying a known current and a second set of electrodes to measure the voltage resulting from the applied current. Ohm's Law can then be used to determine the impedance of the tissue.

[0022] The recording microelectrodes on the electrode modules may be operable individually to record respective neural signals, and/or may be grouped in patterns of different sizes and/or shapes to emulate functionality of a macroelectrode. A macroelectrode can be used to produce a composite signal that may be more appropriate for the desired analysis. Additionally, a composite signal can be interpreted as a signal from a conventional probe (e.g., a probe with a comparatively large electrode) allowing a user to perform similar analysis appropriate for conventional ECoG. A macroelectrode can also be used to stimulate a larger volume of tissue. Furthermore, the neural device can be selectively capable of sensing signals along a gradient of precision such that the user (e.g.

a neurologist) can "zoom" in on a particular area of tissue and sense signals from any number of the microelectrodes in a more precise manner, thereby gathering more detailed and "richer" information about the tissue. The microelectrodes may be operated to scan in varying levels of resolution, such as by operation of the electronic subsystem 440 in FIGURE 4. For instance, as shown in FIGURE 6A, in a coarse scan only a portion of the microelectrodes, loosely distributed across the tissue surface, are activated in a lower "resolution" of signal capture. In the coarse scan mode, a rough area of interest (e.g. dipole surface projection) may identified and can be given closer inspection in a medium scan (FIGURE 6B), in which a more tightly distributed portion of the microelectrodes around the area of interest are activated. The area of interest may be even more closely analyzed in a fine scan mode (FIGURE 6C) that may activate all or nearly all of the nearby microelectrodes around that area. The resolution level of a scan may lie along any point in a gradient of resolution.

[0023] In some embodiments, at least a portion of the electrode modules may be specifically designed for particular functions and/or fits of targeted tissues. For instance, the thickness, footprint area shape, degree of flexibility, distribution or layout of microelectrodes, other module surface characteristics such as bioactive coatings, and/or any suitable characteristic of the module may be customized or specifically designed for a particular region or type of tissue, such as to conform closely with brain surfaces of gyrated brain (e.g. hugging crown of gyrus, following sulcus). In other words, this customizability of the modular electrode array also enables the neural device to be highly conformal and of a specialized design to conform to particular surface features.

[0024] The interconnect functions to transfer signals to and from the modular electrode array. The interconnect can include conductive traces coupled to a respective module, and (as shown in FIGURE 7A) conductive traces can be individually coupled to a microelectrode of the electrode module. The conductive traces may branch bilaterally symmetrically from the centerline of the electrode module. As shown in FIGURE 7B, relative to each electrode module, conductive traces can be arranged in a serpentine pattern, but may alternatively be arranged in any suitable manner. The flexible substrate may include a thin-film electrical signal filter (e.g., a low pass filter) microfabricated and conductively coupled to one or more of the conductive traces.

[0025] FIGURE 8 shows an example of interconnect for a neural device. The interconnect can include conductive traces 820 that can be gathered and helically coiled in groups, although the conductive traces 820 may alternatively be ungrouped and/or uncoiled. The spiral shape of the conductive traces 820 may reduce the electrical currents that are induced during magnetic resonance imaging (MRI), thereby making the neural device safe for use with MRI procedures that are often used to help place ECoG and other neural devices on target tis-

sue. The coiled traces may be insulated with a flexible material (e.g., silicone). The conductive traces 820 may be coiled around a tube of flexible material. The interconnect may also include waveguides (e.g. thin-film waveguides, optical fibers) for guided light transmission in the device that can be used for optical stimulation or optical sensing of the tissue in the vicinity of the device.

[0026] FIGURE 9 shows a flow diagram of an example of method 900 of manufacturing a neural device. Manufacturing the neural device includes manufacturing the modular electrode array and manufacturing the interconnect. At block 905, electrode modules are formed. An electrode module includes a plurality of electrodes disposed on a planar module. The electrodes can be micro-electrodes. One or more apertures can be formed in one or more of the electrode modules. The electrode modules may be manufactured using thin film microfabrication techniques.

[0027] At block 910, multiple electrode modules are assembled into a modular electrode array. The individual electrode modules may include electrodes disposed on a planar flexible substrate and assembling the electrode modules may form a modular flexible substrate that includes the plurality of electrode modules and a spatial separation between adjoining electrode modules to form the modular electrode array. Manufacture of the neural device can include alignment and/or predictable relative positioning of the electrode modules in the modular electrode array. As shown in FIGURES 10A and 10B, manufacturing the modular electrode array can include laying the plurality of modules in an alignment jig, adhering the plurality of modules to one another, and injection molding a backing to the adhered modules. The jig can define recesses, each receiving a respective module, and networked channels that join two or more recesses together. The jig can include a 4x4 rectangular grid for 16 modules, but may alternatively have any suitable number of recesses in other arrangements. For the general case, the modular electrode array can include X rows of electrode modules and Y columns of electrode modules to an X by Y electrode array; where X and Y are positive integers. In laying the modules in respective recesses, the respective interconnects can be gathered at one end and stacked in groups. Adhering the plurality of modules to one another can include applying epoxy to adjoining surfaces of the modules. The epoxy can be a UV-curable epoxy, but may be any suitable kind of adhesive. Alternatively, the modules may be joined with other coupling processes or mechanisms such as heat welding or with fasteners.

[0028] The process can include attaching a backing to the modular flexible substrate. The backing can be attached by injection molding or adhering the backing to the modular flexible substrate. Injection molding a backing to the adhered modules can include placing the adhered modules in a device mold, injecting backing material into the device mold, curing the backing material, and releasing modular electrode array from the device

mold. As shown in FIGURES 10C and 10D, the adhered modules can be placed in a first portion (e.g. bottom half) device mold and a second portion (e.g. top half) device mold can be aligned to the first portion device mold with pegs. After the first and second portion molds are clamped together, the backing material (e.g. silicone) can be injected into the device mold and cured in an oven, thereby simultaneously forming the backing shape and adhering the backing material to the coupled modules. After curing, the device mold is opened and the backed modular electrode array is released. Other variations of the injection molding process may be used, such as those known and used by one ordinarily skilled in the art.

[0029] Returning to FIGURE 9, conductive interconnect is formed and coupled to the electrodes at 915. The conductive interconnect can include conductive traces arranged in a serpentine pattern. The conductive traces can be separated and folded into a different arrangement (e.g., substantially straight). Interconnect can also be formed by grouping the conductive traces and helically coiling the grouped traces. Insulation can be injection molded around the coiled interconnect. At least a portion of the neural device may remain in the device mold during these steps. As shown in FIGURE 11A, a group of conductive channels helically coiled or wrapped around a tube can be placed in a coiling jig that regulates the spacing and/or tension of the coiling. During coiling, portions of the traces may be periodically tacked to the tube (e.g., with cyanoacrylate adhesive) to prevent uncoiling. The tube can be made of a flexible material such as silicone, and may include a stiffener such as a metal wire inserted in a lumen of the tube, to increase rigidity of the tube during coiling of the lead. The stiffener may or may not be removed from the tube after coiling. In some examples, each group of conductive channels is preferably coiled separately. For instance, four different groups of traces may be coiled around four different tubes.

[0030] Injection molding the insulation around the coiled conductive traces can be similar to the step of injection molding the backing of the modular electrode array and/or other injection molding processes. As shown in FIGURES 11B and 11C, the coiled traces are preferably placed in a first portion (e.g. bottom half) interconnect mold and a second portion (e.g. top half) is aligned to the first portion interconnect mold with pegs. After the first and second portion interconnect molds are clamped together, the insulation material (e.g. silicone) is injected into the interconnect mold and cured in an oven, thereby simultaneously forming the insulation shape and adhering the insulation around the coiled interconnects. Each group of the coiled traces can be individually overmolded with insulation at separate times, although alternatively the coiled traces may simultaneously be overmolded with insulation.

[0031] In some embodiments, some portions of the device molds, coiling jig, and/or interconnect molds may be reused it multiple steps. For instance, a portion of the bottom half device mold may be adapted to clamp to (1) the

upper half device mold when injecting molding the backing of the modular electrode array, (2) the coiling jig when coiling the interconnects and (3) a portion of the bottom half interconnect mold when injection molding the insulation around the coiled interconnects. However, the device may alternatively be placed in separate molds and/or jigs for each step of the process.

ADDITIONAL NOTES AND EXAMPLES

[0032] The above detailed description includes references to the accompanying drawings, which form a part of the detailed description. The drawings show, by way of illustration, specific embodiments in which the invention can be practiced. These embodiments are also referred to herein as "examples."

[0033] In this document, the terms "a" or "an" are used, as is common in patent documents, to include one or more than one, independent of any other instances or usages of "at least one" or "one or more." In this document, the term "or" is used to refer to a nonexclusive or, such that "A or B" includes "A but not B," "B but not A," and "A and B," unless otherwise indicated. In the appended claims, the terms "including" and "in which" are used as the plain-English equivalents of the respective terms "comprising" and "wherein." Also, in the following claims, the terms "including" and "comprising" are open-ended, that is, a system, device, article, or process that includes elements in addition to those listed after such a term in a claim are still deemed to fall within the scope of that claim. Moreover, in the following claims, the terms "first," "second," and "third," etc. are used merely as labels, and are not intended to impose numerical requirements on their objects.

[0034] Method examples described herein can be machine or computer-implemented at least in part. Some examples can include a computer-readable medium or machine-readable medium encoded with instructions operable to configure an electronic device to perform methods as described in the above examples. An implementation of such methods can include code, such as microcode, assembly language code, a higher-level language code, or the like. Such code can include computer readable instructions for performing various methods. The code can form portions of computer program products. Further, the code can be tangibly stored on one or more volatile or non-volatile computer-readable media during execution or at other times. These computer-readable media can include, but are not limited to, hard disks, removable magnetic disks, removable optical disks (e.g., compact disks and digital video disks), magnetic cassettes, memory cards or sticks, random access memories (RAM's), read only memories (ROM's), and the like.

[0035] The above description is intended to be illustrative, and not restrictive. For example, the above-described examples (or one or more aspects thereof) may be used in combination with each other. Other embodiments can be used, such as by one of ordinary skill in

the art upon reviewing the above description.

Claims

1. An apparatus comprising:

a modular electrode array including:

a modular flexible substrate including:

a plurality of electrode modules (110), wherein an electrode module includes a plurality of electrodes (115) disposed on a planar module; and a spatial separation between the electrode modules; and

at least one conductive interconnect coupled to the plurality

of electrodes, wherein the at least one conductive interconnect includes one or more groups of conductive traces (820), **characterized by** the one or more groups of conductive traces being helically coiled.

2. The apparatus of claim 1, including:

a multiplexer circuit (545) having signal inputs, select inputs, and one or more signal outputs, wherein the signal inputs to the multiplexer circuit are electrically coupled to the conductive interconnect; and

a selector circuit (550) electrically coupled to the select inputs of the multiplexer circuit and configured to activate the select inputs to direct a signal from an input of the multiplexer circuit to an output of the multiplexer circuit.

3. The apparatus of claim 1 or claim 2, wherein the conductive interconnect includes conductive traces arranged in a serpentine pattern.

4. The apparatus of claim 1 or claim 2, wherein the groups of conductive traces are helically coiled around a tube containing flexible material.

5. The apparatus of any one of claims 1-4, wherein the flexible substrate includes a flexible thin-film substrate.

6. The apparatus of any one of claims 1-5, wherein the modular flexible substrate includes one or more thin film electrical signal filters conductively coupled to the conductive interconnect.

7. The apparatus of any one of claims 1-6, wherein one

or more of the electrode modules includes one or more elongate apertures extending between rows of electrodes of the plurality of electrodes and configured to permit placement of a penetrating electrode therethrough, and preferably including a wave guide configured to deliver light to at least a portion of the one or more apertures.

8. The apparatus of any one of claims 1-7, wherein the modular flexible substrate includes one or more penetrating electrodes.

9. The apparatus of any one of claims 1-8, wherein the plurality of electrodes are configured to both receive a neural signal from a neural signal source and provide electrical stimulation energy to a neural stimulation target.

10. A method comprising:

disposing a plurality of electrodes on a plurality of planar modules to form a plurality of electrode modules;

forming a modular flexible substrate, wherein the modular flexible substrate includes the plurality of electrode modules and a spatial separation between adjoining electrode modules to form a modular electrode array; and

coupling a conductive interconnect to the plurality of electrodes, wherein the conductive interconnect includes one or more groups of conductive traces; **characterized in that** coupling the conductive interconnect includes helically coiling the one or more groups of conductive traces.

11. The method of claim 10, including attaching a backing to the modular flexible substrate, wherein attaching the backing preferably includes (i) injection molding a silicone backing and attaching the modular flexible substrate to the silicone backing, or (ii) adhering a thin-film backing to the modular flexible substrate.

12. A system comprising:

a plurality of electrically conductive leads; an apparatus in accordance with any one of claim 1 to claim 9; and

an electronic subsystem electrically coupled to the conductive interconnect and the electrically conductive leads, wherein the electronic subsystem is configured to transfer sensed electrical signals from the conductive interconnect to the plurality of electrically conductive leads.

13. The system of claim 12, wherein the conductive interconnect includes a plurality of conductive traces, wherein the number of electrically conductive leads is less than the number of conductive traces, and

wherein the electronic subsystem includes a multiplexer circuit configured to selectively transfer signals sensed by a subset of the plurality of conductive traces to one or more of the electrically conductive leads.

14. The system of claim 12 or claim 13, wherein the electronic subsystem includes a noise reduction circuit.

15. The system of any one of claims 12-14, including a recording system electrically coupled to the plurality of electrically conductive leads.

15 Patentansprüche

1. Vorrichtung, die Folgendes umfasst:

ein modulares Elektroden-Array mit:

einem modularen flexiblen Substrat mit:

mehreren Elektrodenmodulen (110), wobei ein Elektrodenmodul mehrere Elektroden (115) aufweist, die auf einem planaren Modul angeordnet sind; und
einer räumlichen Trennung zwischen den Elektrodenmodulen; und

wenigstens einer leitfähigen Verbindung, die mit den mehreren Elektroden gekoppelt ist, wobei die wenigstens eine leitfähige Verbindung eine oder mehrere Gruppen von Leiterbahnen (820) beinhaltet, **dadurch gekennzeichnet, dass** die ein oder mehreren Gruppen von Leiterbahnen spiralförmig gewunden sind.

2. Vorrichtung nach Anspruch 1, die Folgendes umfasst:

eine Multiplexer-Schaltung (545) mit Signaleingängen, Auswahleingängen und einem oder mehreren Signalausgängen, wobei die Signaleingänge zur Multiplexer-Schaltung elektrisch mit der leitfähigen Verbindung gekoppelt sind; und

eine Auswahlschaltung (550), die elektrisch mit den Auswahleingängen der Multiplexer-Schaltung gekoppelt und zum Aktivieren der Auswahleingänge konfiguriert sind, um ein Signal von einem Eingang der Multiplexer-Schaltung zu einem Ausgang der Multiplexer-Schaltung zu leiten.

3. Vorrichtung nach Anspruch 1 oder Anspruch 2, wobei die leitfähige Verbindung in einem Serpentin-

- muster angeordnete Leiterbahnen beinhaltet.
4. Vorrichtung nach Anspruch 1 oder Anspruch 2, wobei die Gruppen von Leiterbahnen spiralförmig um eine flexible Material enthaltende Röhre gewunden sind. 5
5. Vorrichtung nach einem der Ansprüche 1-4, wobei das flexible Substrat ein flexibles Dünnschichtsubstrat beinhaltet. 10
6. Vorrichtung nach einem der Ansprüche 1-5, wobei das modulare flexible Substrat ein oder mehrere elektrische Dünnschicht-Signalfilter beinhaltet, die leitfähig mit der leitfähigen Verbindung gekoppelt sind. 15
7. Vorrichtung nach einem der Ansprüche 1-6, wobei eines oder mehrere der Elektrodenmodule eine oder mehrere längliche Öffnungen beinhaltet, die zwischen Reihen von Elektroden der mehreren Elektroden verlaufen und zum Zulassen des Verschiebens einer penetrierenden Elektrode durch sie konfiguriert sind, und vorzugsweise einen Wellenleiter aufweist, der zum Zuführen von Licht zu wenigstens einem Teil der ein oder mehreren Öffnungen konfiguriert ist. 20
8. Vorrichtung nach einem der Ansprüche 1-7, wobei das modulare flexible Substrat eine oder mehrere penetrierende Elektroden beinhaltet. 30
9. Vorrichtung nach einem der Ansprüche 1-8, wobei die mehreren Elektroden sowohl zum Empfangen eines neuronalen Signals von einer neuronalen Signalquelle als auch zum Zuführen von elektrischer Stimulationsenergie zu einem neuronalen Stimulationsziel konfiguriert sind. 35
10. Verfahren, das Folgendes beinhaltet: 40
- Anordnen von mehreren Elektroden auf mehreren planaren Modulen zum Bilden von mehreren Elektrodenmodulen;
- Bilden eines modularen flexiblen Substrats, wobei das modulare flexible Substrat die mehreren Elektrodenmodule und eine räumliche Trennung zwischen benachbarten Elektrodenmodulen zum Bilden eines modularen Elektroden-Array beinhaltet; und 50
- Koppeln einer leitfähigen Verbindung mit den mehreren Elektroden, wobei die leitfähige Verbindung eine oder mehrere Gruppen von Leiterbahnen beinhaltet;
- dadurch gekennzeichnet, dass** das Koppeln der leitfähigen Verbindung das spiralförmige Winden der ein oder mehreren Gruppen von Leiterbahnen beinhaltet. 55

11. Verfahren nach Anspruch 10, das das Anbringen eines Trägermaterials an dem modularen flexiblen Substrat beinhaltet, wobei das Anbringen des Trägermaterials vorzugsweise (i) das Spritzformen eines Silikonträgermaterials und das Anbringen des modularen flexiblen Substrats an dem Silikonträgermaterial oder (ii) das Kleben eines Dünnschichtträgermaterials an das modulare flexible Substrat beinhaltet.

12. System, das Folgendes umfasst:

mehrere elektrisch leitfähige Leitungen;
eine Vorrichtung nach einem der Ansprüche 1 bis 9; und
ein elektronisches Subsystem, das elektrisch mit der leitfähigen Verbindung und den elektrisch leitfähigen Leitungen verbunden ist, wobei das elektronische Subsystem zum Übertragen von erfassten elektrischen Signalen von der leitfähigen Verbindung zu den mehreren elektrisch leitfähigen Leitungen konfiguriert ist.

13. System nach Anspruch 12, wobei die leitfähige Verbindung mehrere Leiterbahnen beinhaltet, wobei die Anzahl von elektrisch leitfähigen Leitungen geringer ist als die Anzahl von Leiterbahnen und wobei das elektronische Subsystem eine Multiplexer-Schaltung beinhaltet, konfiguriert zum selektiven Übertragen von von einem Teilsatz der mehreren Leiterbahnen erfassten Übertragungssignalen zu einer oder mehreren der elektrisch leitfähigen Leitungen.

14. System nach Anspruch 12 oder Anspruch 13, wobei das elektronische Subsystem eine Geräuschunterdrückungsschaltung beinhaltet.

15. System nach einem der Ansprüche 12-14, das ein Aufzeichnungssystem aufweist, das elektrisch mit den mehreren elektrisch leitfähigen Leitungen gekoppelt ist.

Revendications

1. Appareil comportant :

une rangée d'électrodes modulaires comprenant :

un substrat souple modulaire comprenant :

une pluralité de modules d'électrodes (110), dans lequel un module d'électrodes comprend une pluralité d'électrodes (115) disposées sur un module planaire ; et
une séparation spatiale entre les mo-

dules d'électrodes ; et

au moins une interconnexion conductrice couplée à la pluralité d'électrodes, dans lequel ladite au moins une interconnexion conductrice comprend un ou plusieurs groupes de traces conductrices (820), **caractérisé par** lesdits un ou plusieurs groupes de traces conductrices qui sont enroulés de manière hélicoïdale.

2. Appareil selon la revendication 1, comprenant :

un circuit multiplexeur (545) ayant des entrées de signaux, des entrées de sélection, et une ou plusieurs sorties de signaux, dans lequel les entrées de signaux à destination du circuit multiplexeur sont couplées électriquement à l'interconnexion conductrice ; et

un circuit sélecteur (550) couplé électriquement aux entrées de sélection du circuit multiplexeur et configuré pour activer les entrées de sélection pour diriger un signal depuis une entrée du circuit multiplexeur jusqu'à une sortie du circuit multiplexeur.

3. Appareil selon la revendication 1 ou la revendication 2, dans lequel l'interconnexion conductrice comprend des traces conductrices agencées selon un motif en serpent.

4. Appareil selon la revendication 1 ou la revendication 2, dans lequel les groupes de traces conductrices sont enroulés de manière hélicoïdale autour d'un tube contenant un matériau souple.

5. Appareil selon l'une quelconque des revendications 1 à 4, dans lequel le substrat souple comprend un substrat souple à couches minces.

6. Appareil selon l'une quelconque des revendications 1 à 5, dans lequel le substrat souple modulaire comprend un ou plusieurs filtres de signaux électriques à couches minces couplés de manière conductrice à l'interconnexion conductrice.

7. Appareil selon l'une quelconque des revendications 1 à 6, dans lequel un ou plusieurs parmi les modules d'électrodes comprend une ou plusieurs ouvertures allongées s'étendant entre des rangées d'électrodes de la pluralité d'électrodes et configurées pour permettre la mise en place d'une électrode de pénétration au travers de celles-ci, et comprenant de préférence un guide d'ondes configuré pour délivrer de la lumière à au moins une partie desdites une ou plusieurs ouvertures.

8. Appareil selon l'une quelconque des revendications

1 à 7, dans lequel le substrat souple modulaire comprend une ou plusieurs électrodes de pénétration.

9. Appareil selon l'une quelconque des revendications 1 à 8, dans lequel les électrodes de la pluralité d'électrodes sont configurées pour à la fois recevoir un signal neuronal en provenance d'une source de signaux neuronaux et fournir de l'énergie de stimulation électrique à une cible de stimulation neuronale.

10. Procédé comportant les étapes consistant à :

disposer une pluralité d'électrodes sur une pluralité de modules planaires pour former une pluralité de modules d'électrodes ;

former un substrat souple modulaire, dans lequel le substrat souple modulaire comprend la pluralité de modules d'électrodes et une séparation spatiale entre des modules d'électrodes voisins pour former une rangée d'électrodes modulaires ; et

coupler une interconnexion conductrice à la pluralité d'électrodes, dans lequel l'interconnexion conductrice comprend un ou plusieurs groupes de traces conductrices ;

caractérisé en ce que l'étape consistant à coupler l'interconnexion conductrice comprend l'étape consistant à enrouler de manière hélicoïdale lesdits un ou plusieurs groupes de traces conductrices.

11. Procédé selon la revendication 10, comprenant l'étape consistant à attacher un matériau de support sur le substrat souple modulaire, dans lequel l'étape consistant à attacher le matériau de support comprend de préférence (i) le moulage par injection d'un support en silicium et la fixation du substrat souple modulaire sur le support en silicium, ou (ii) l'adhésion d'un support à couches minces sur le substrat souple modulaire.

12. Système comportant :

une pluralité de fils électriquement conducteurs ;

un appareil selon l'une quelconque des revendications 1 à 9 ; et

un sous-système électronique couplé électriquement à l'interconnexion conductrice et aux fils électriquement conducteurs, dans lequel le sous-système électronique est configuré pour transférer des signaux électriques détectés en provenance de l'interconnexion conductrice jusqu'à la pluralité de fils électriquement conducteurs.

13. Système selon la revendication 12, dans lequel l'interconnexion conductrice comprend une pluralité de

traces conductrices, dans lequel le nombre de fils électriquement conducteurs est inférieur au nombre de traces conductrices, et dans lequel le sous-système électronique comprend un circuit multiplexeur configuré pour transférer de manière sélective des signaux détectés par un sous-ensemble de la pluralité de traces conductrices jusqu'à un ou plusieurs parmi les fils électriquement conducteurs. 5

14. Système selon la revendication 12 ou la revendication 13, dans lequel le sous-système électronique comprend un circuit de réduction de bruit. 10

15. Système selon l'une quelconque des revendications 12 à 14, comprenant un système d'enregistrement couplé électriquement à la pluralité de fils électriquement conducteurs. 15

20

25

30

35

40

45

50

55

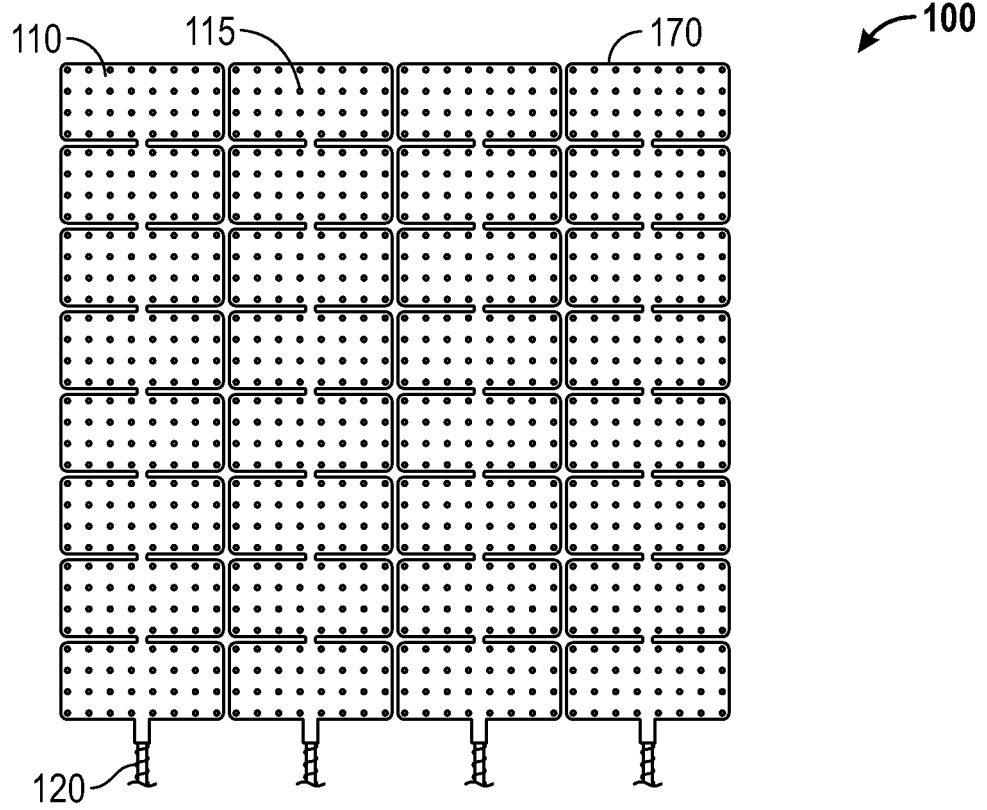

FIG. 1

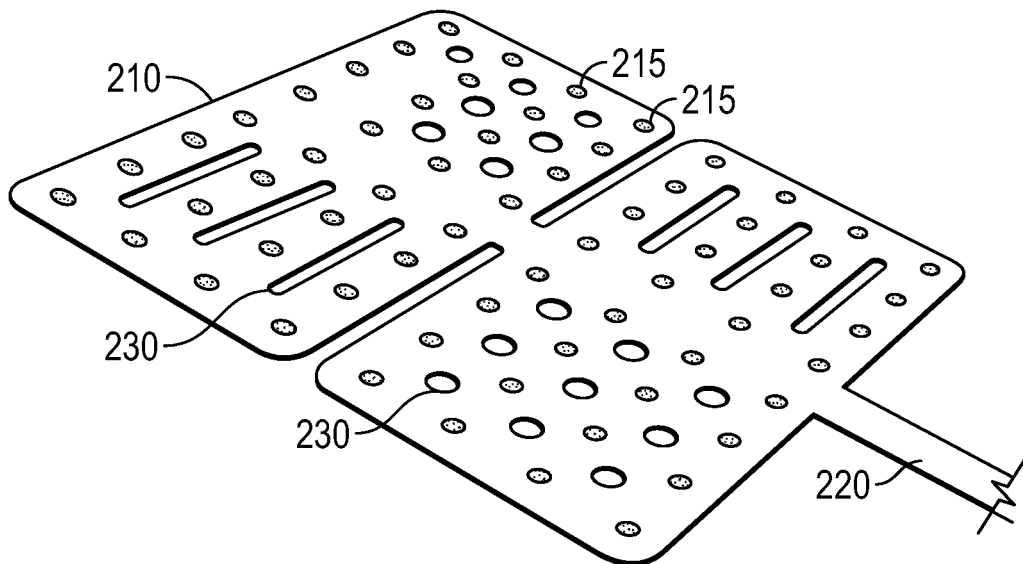

FIG. 2

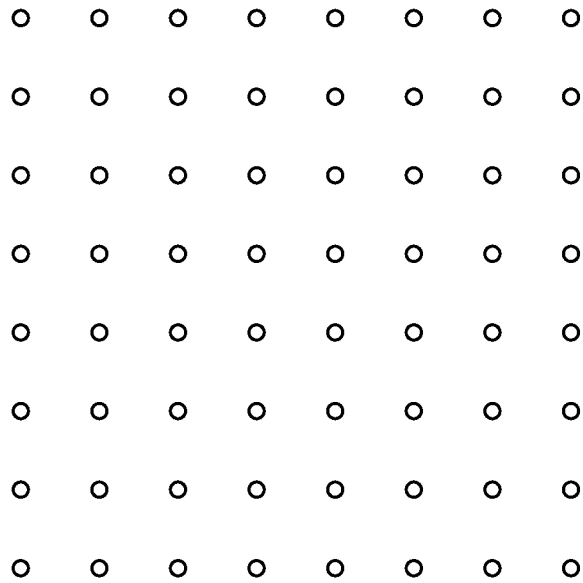

FIG. 3A

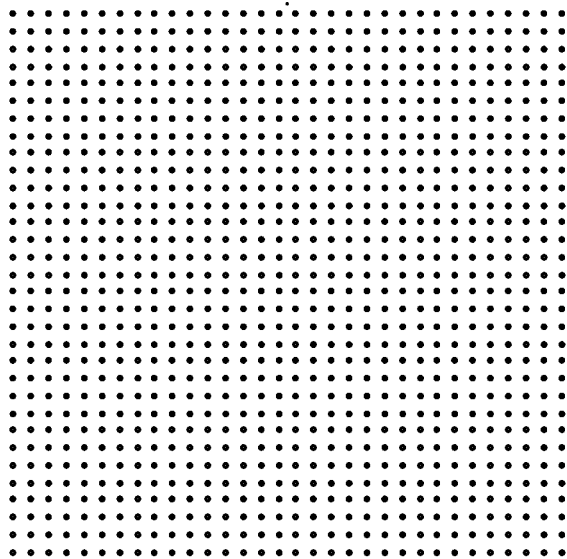

FIG. 3B

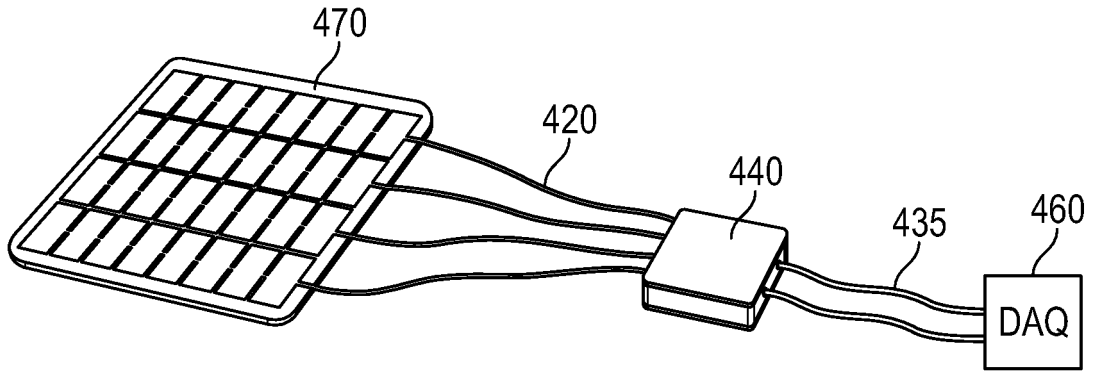

FIG. 4

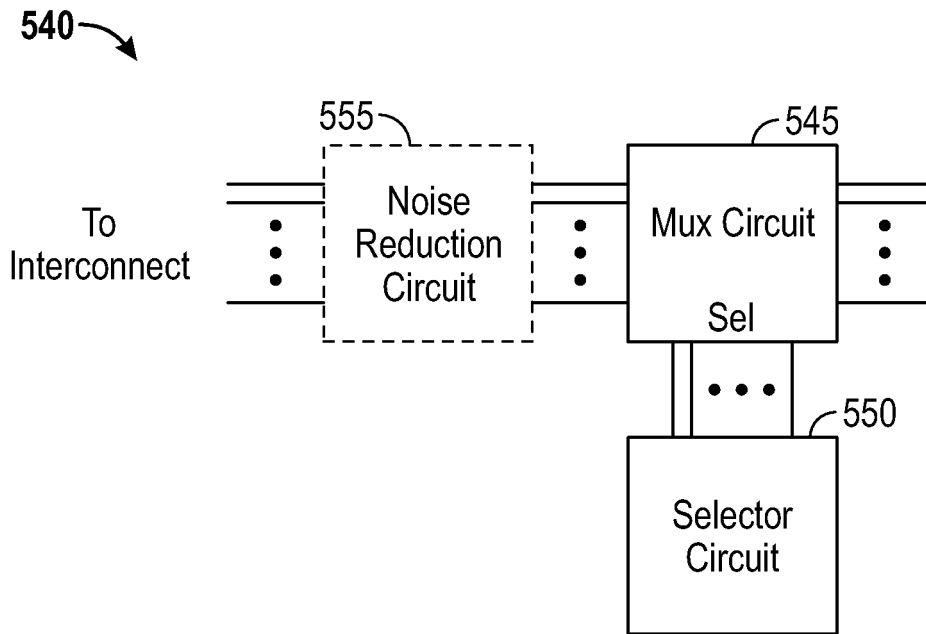

FIG. 5

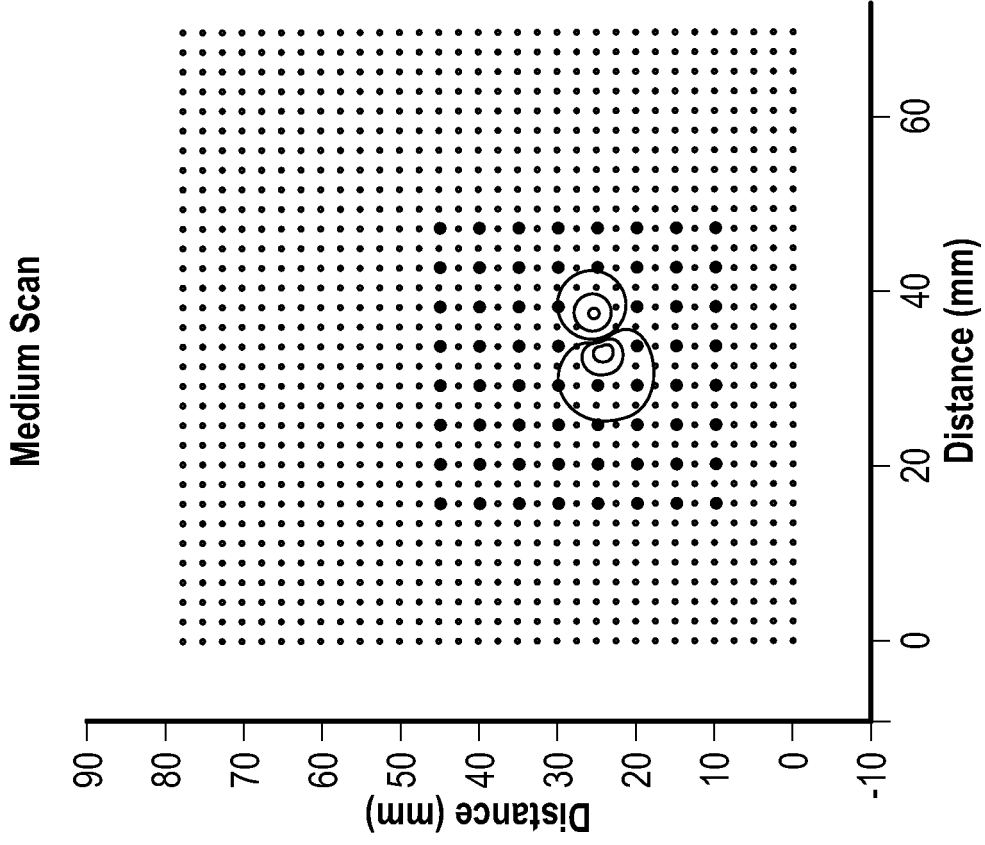

FIG. 6B

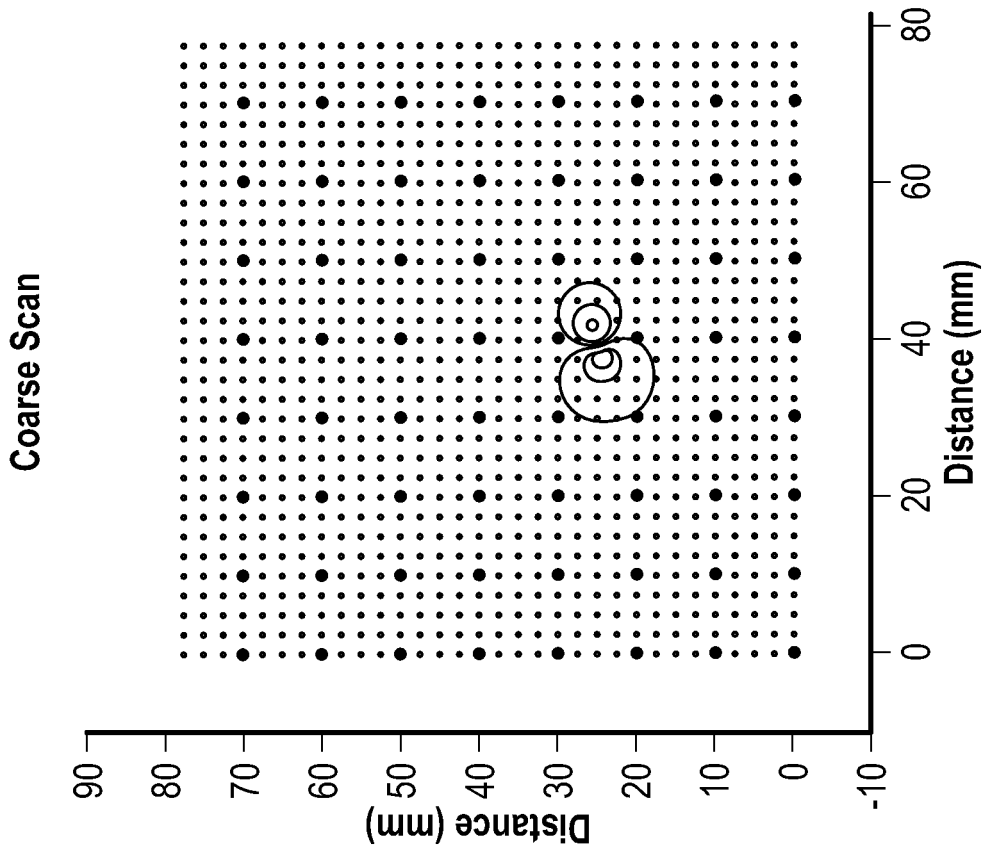

FIG. 6A

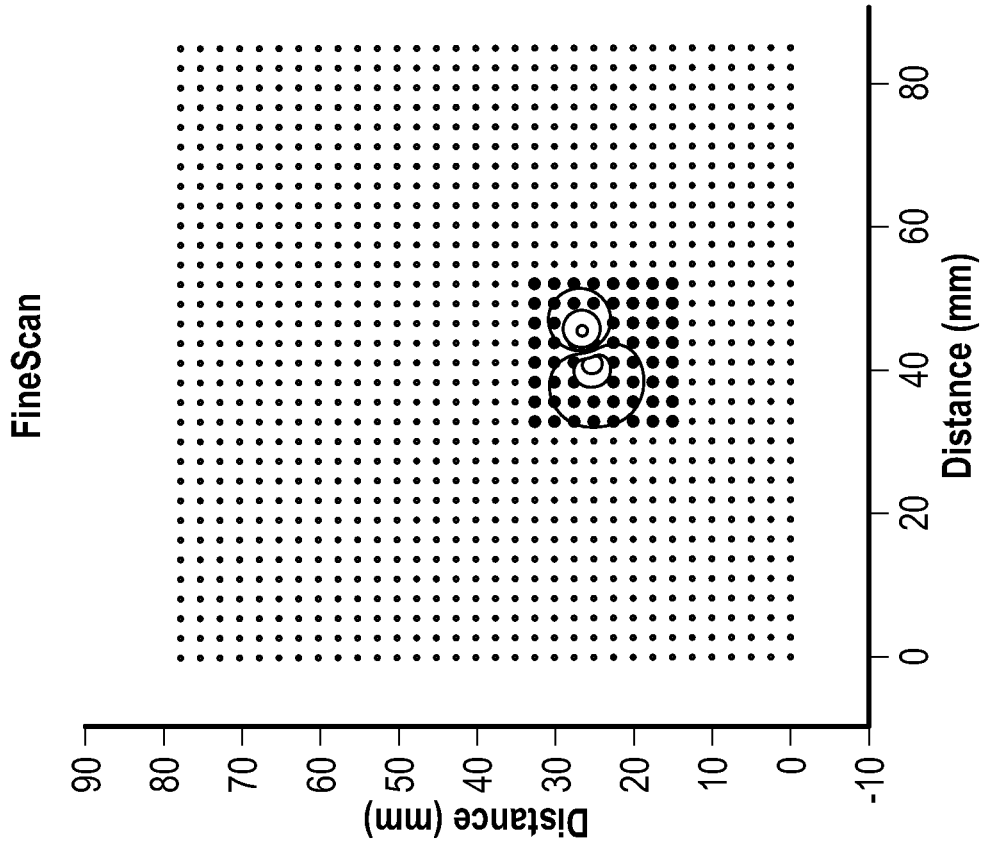

FIG. 6C

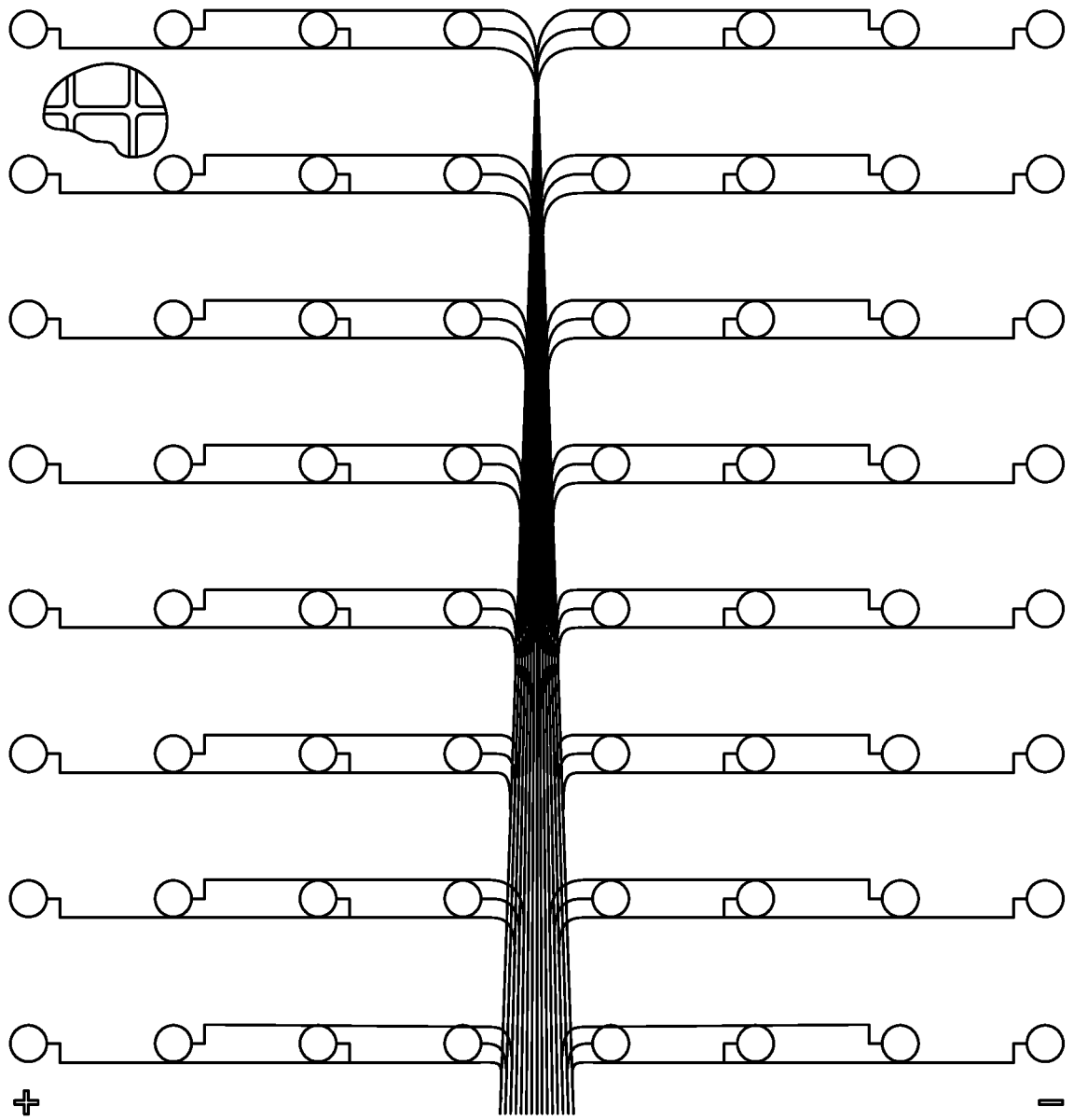

FIG. 7A

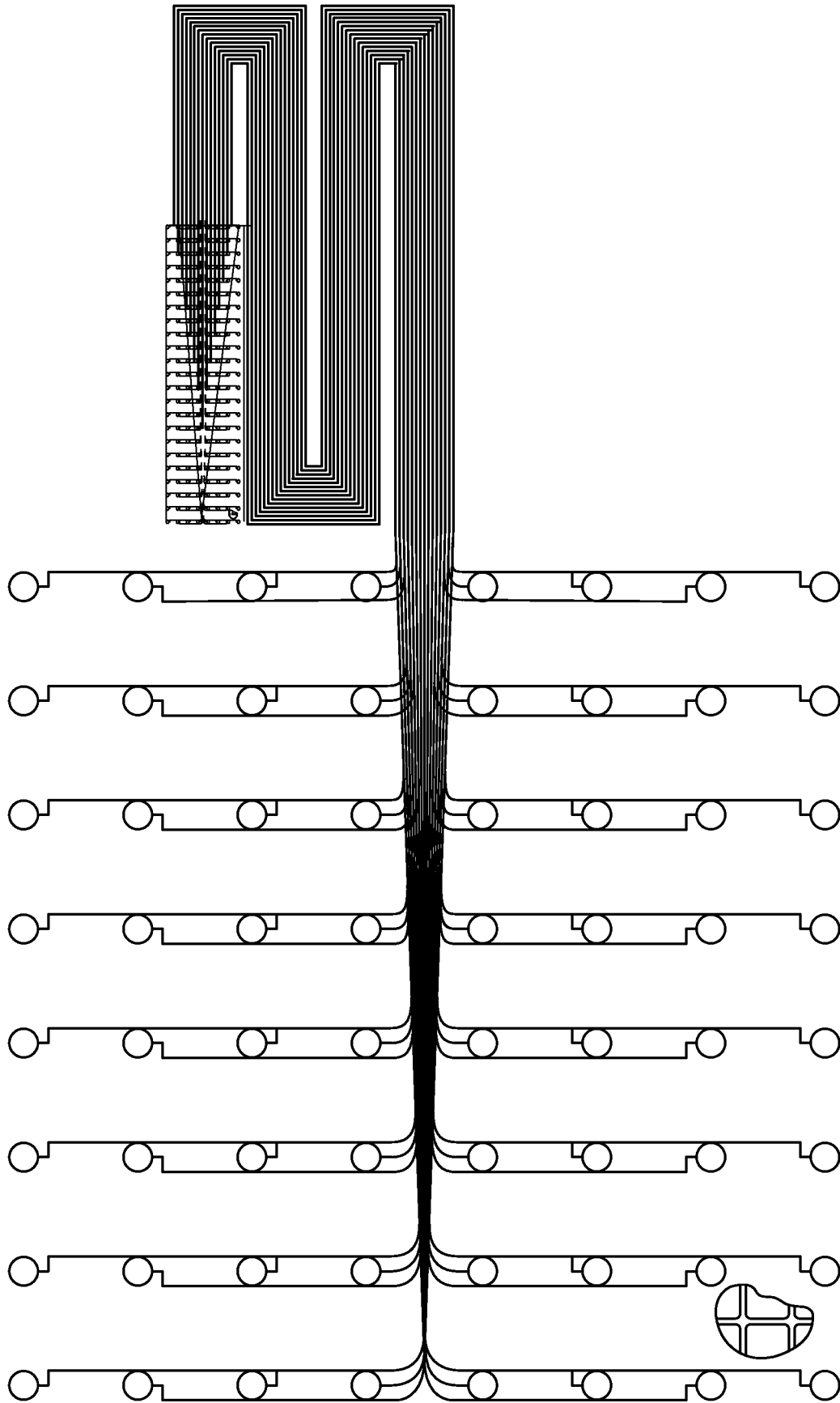

FIG. 7B

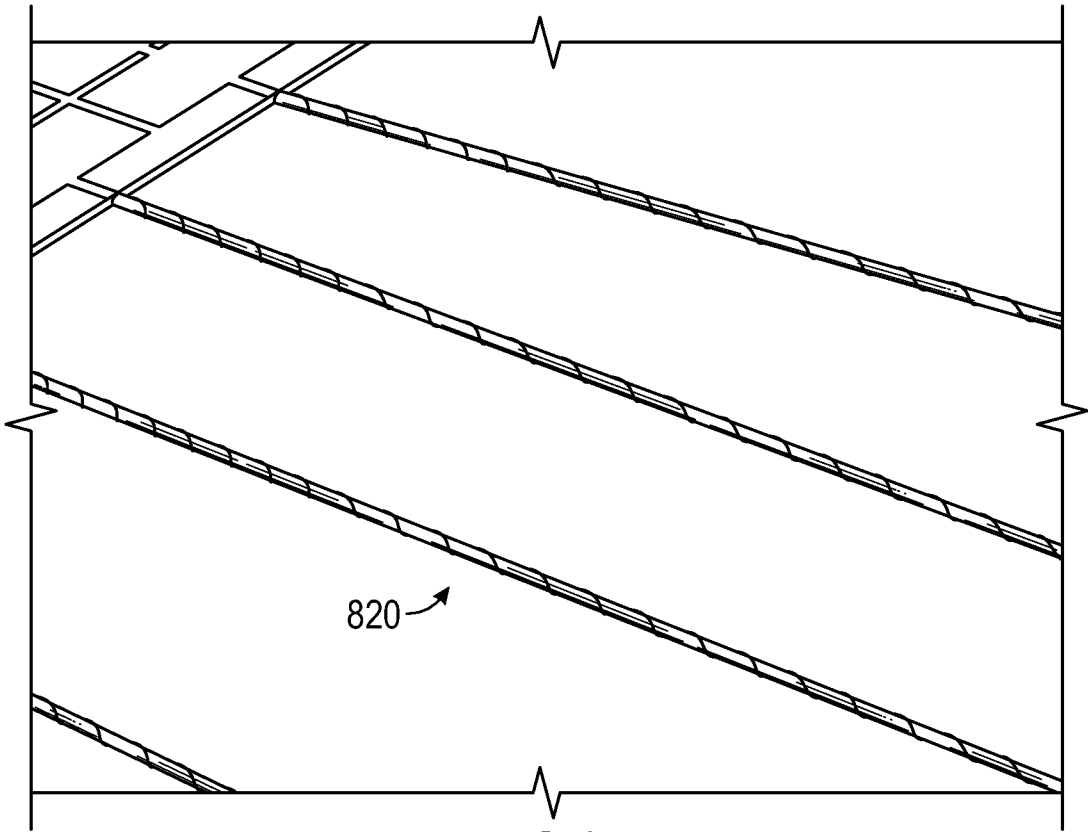

FIG. 8

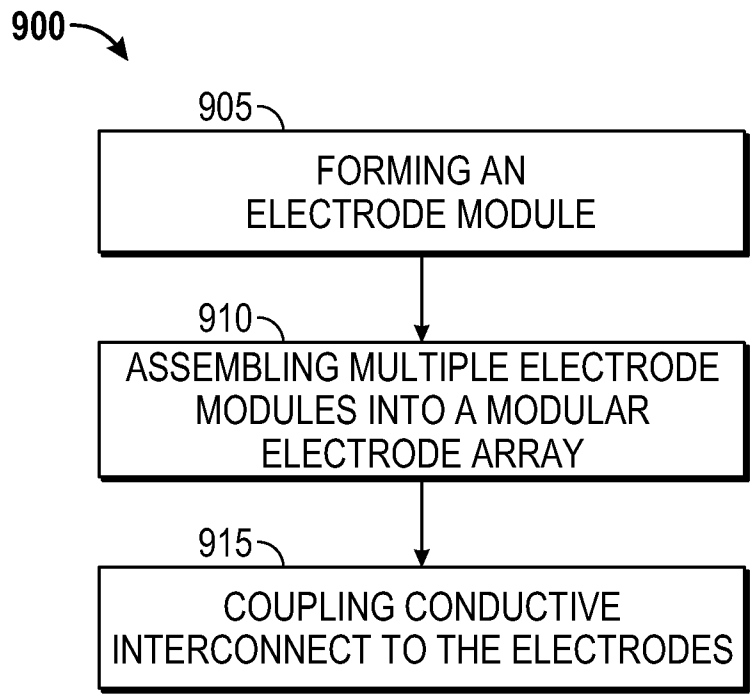

FIG. 9

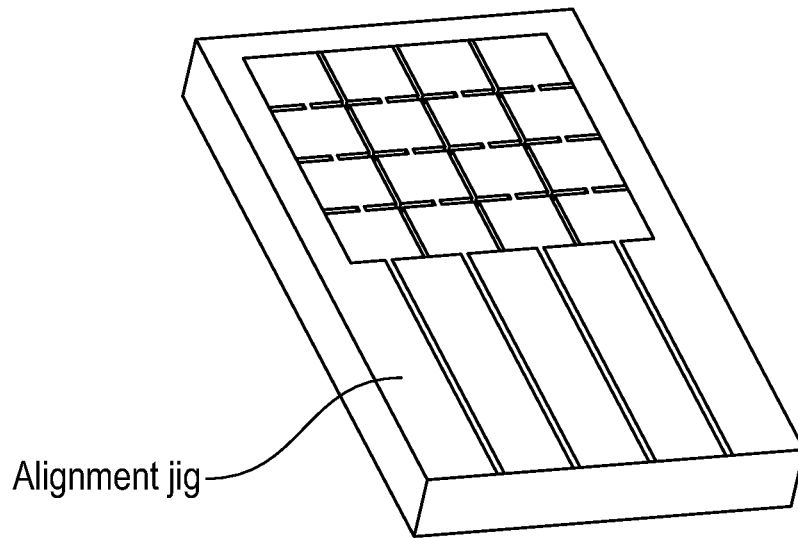

FIG. 10A

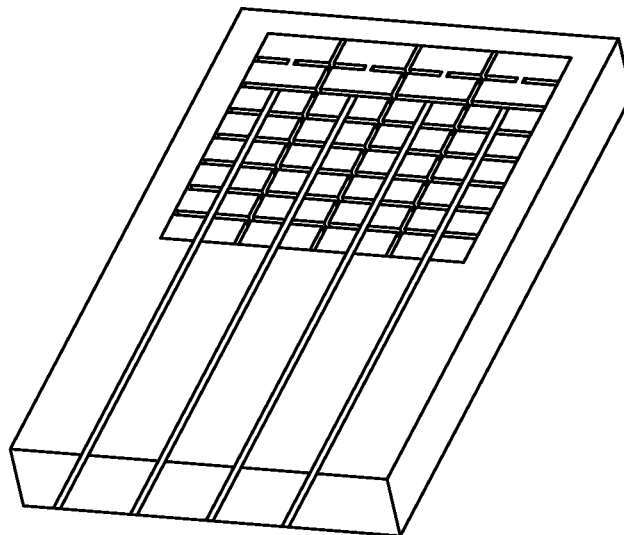
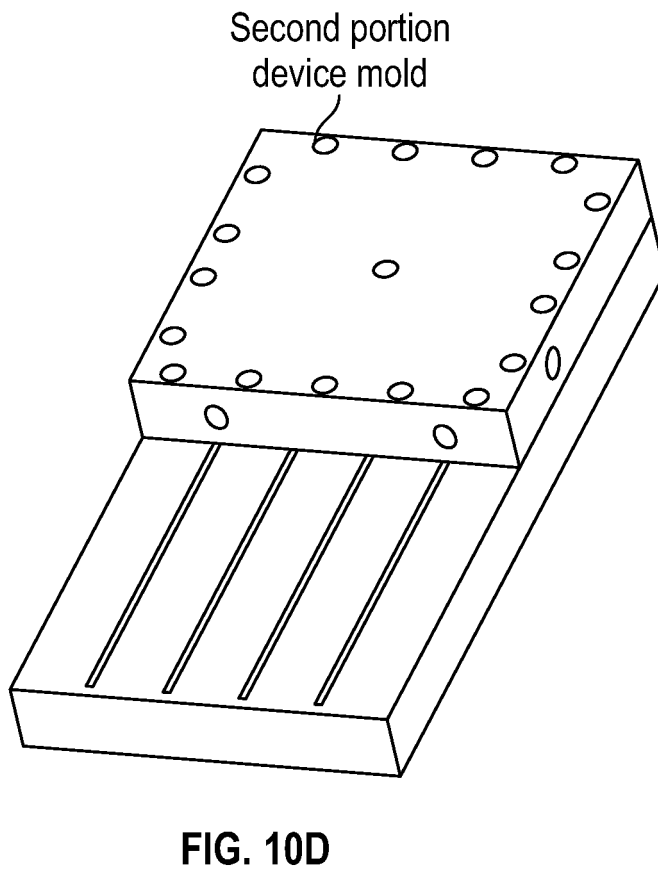
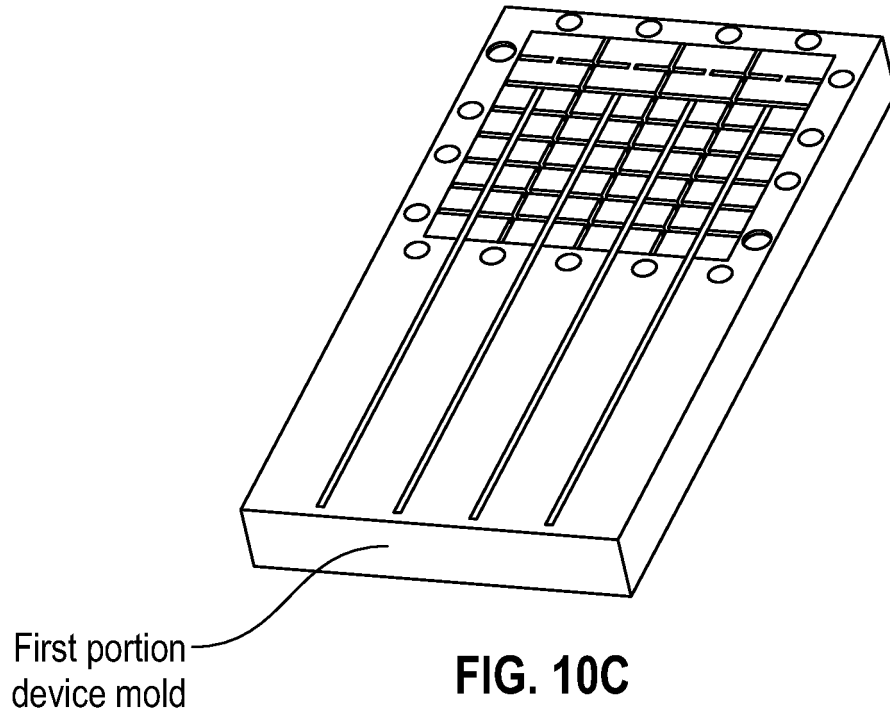

FIG. 10B



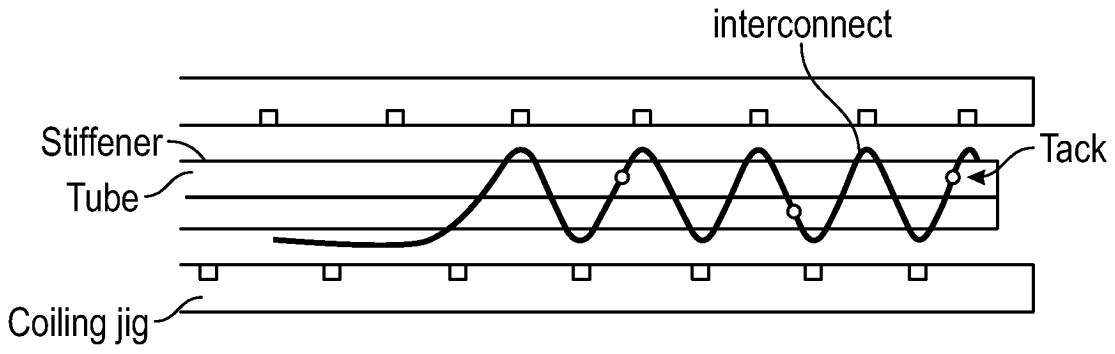

FIG. 11A

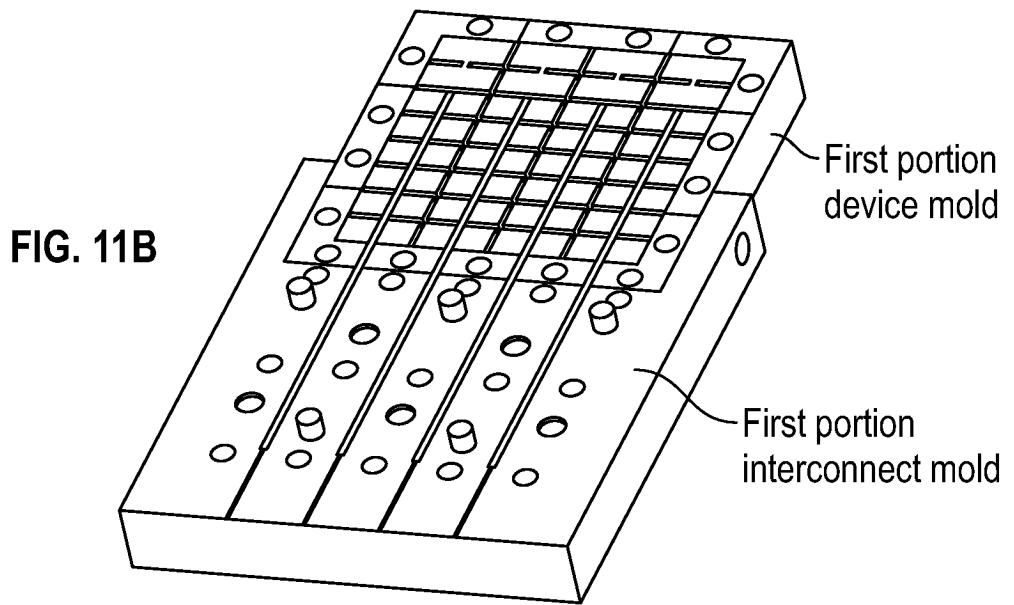

FIG. 11B

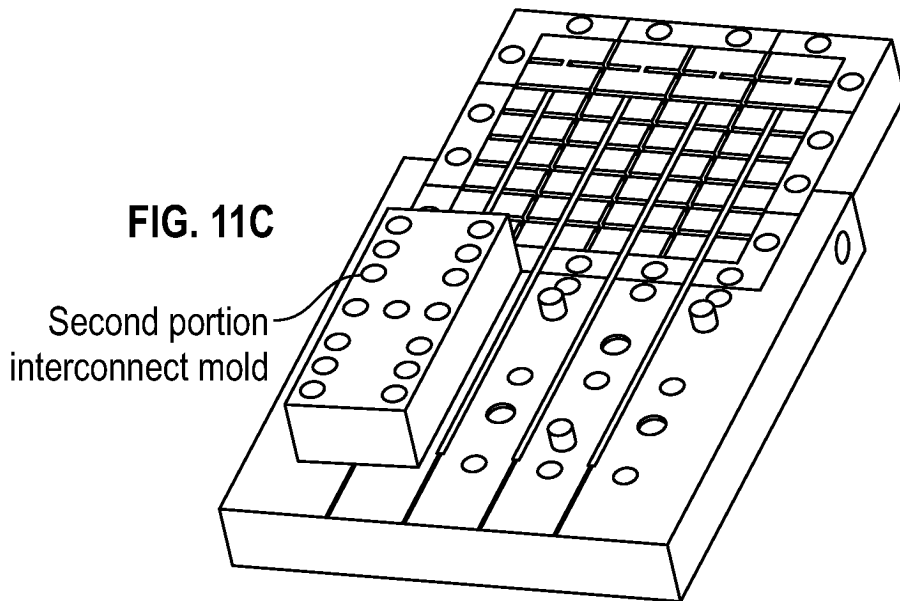

FIG. 11C

REFERENCES CITED IN THE DESCRIPTION

This list of references cited by the applicant is for the reader's convenience only. It does not form part of the European patent document. Even though great care has been taken in compiling the references, errors or omissions cannot be excluded and the EPO disclaims all liability in this regard.

Patent documents cited in the description

- US 20100198297 A [0003]
- US 20050154435 A [0004]
- WO 2011067297 A [0005]
- WO 2010055421 A [0006]
- WO 2005058145 A [0007]
- WO 2011057276 A [0008]

专利名称(译)	具有模块电极阵列的神经装置		
公开(公告)号	EP2736587A2	公开(公告)日	2014-06-04
申请号	EP2012751636	申请日	2012-07-24
[标]申请(专利权)人(译)	神经连结科技公司		
申请(专利权)人(译)	NEURONEXUS TECHNOLOGIES , INC.		
当前申请(专利权)人(译)	NEURONEXUS TECHNOLOGIES , INC.		
[标]发明人	KIPKE DARYL R VETTER RIO J KONG KC HETKE JAMILLE ANDERSON DAVID		
发明人	KIPKE, DARYL R. VETTER, RIO J. KONG, KC HETKE, JAMILLE ANDERSON, DAVID		
IPC分类号	A61N1/05 A61B5/0478 A61B5/00 A61N5/06		
CPC分类号	A61N1/36064 A61B5/0059 A61B5/04001 A61B5/0478 A61B5/4064 A61B5/4094 A61B2562/046 A61N1/0531 A61N5/06 A61N5/0622 Y10T29/49117		
优先权	61/511343 2011-07-25 US		
其他公开文献	EP2736587B1		
外部链接	Espacenet		

摘要(译)

一种装置包括柔性基板，该柔性基板包括设置在柔性基板上的模块化电极阵列。模块化电极阵列包括多个电极模块，其中电极模块包括多个电极。柔性基板还包括模块化电极阵列的电极模块与耦合到多个电极的电极的导电互连之间的空间间隔。