

(19)



(11)

EP 2 658 480 B1

(12)

EUROPEAN PATENT SPECIFICATION

(45) Date of publication and mention of the grant of the patent:

01.11.2017 Bulletin 2017/44

(21) Application number: **11863521.8**

(22) Date of filing: **29.12.2011**

(51) Int Cl.:

A61F 2/24 <small>(2006.01)</small>	A61M 25/01 <small>(2006.01)</small>
A61F 2/76 <small>(2006.01)</small>	A61B 1/018 <small>(2006.01)</small>
A61B 1/04 <small>(2006.01)</small>	A61B 1/313 <small>(2006.01)</small>
A61B 5/00 <small>(2006.01)</small>	A61B 17/04 <small>(2006.01)</small>
A61B 17/08 <small>(2006.01)</small>	A61B 17/34 <small>(2006.01)</small>
A61B 1/00 <small>(2006.01)</small>	A61B 17/06 <small>(2006.01)</small>
A61B 17/00 <small>(2006.01)</small>	A61M 39/06 <small>(2006.01)</small>
A61M 37/00 <small>(2006.01)</small>	A61B 90/00 <small>(2016.01)</small>

(86) International application number:

PCT/US2011/067884

(87) International publication number:

WO 2012/141757 (18.10.2012 Gazette 2012/42)

(54) **EXCHANGEABLE SYSTEM FOR MINIMALLY INVASIVE BEATING HEART REPAIR OF HEART VALVE LEAFLETS**

AUSTAUSCHBARES SYSTEM FÜR MINIMAL INVASIVE REPARATUR VON HERZKLAPPENBLÄTTCHEN BEI SCHLAGENDEM HERZEN

SYSTÈME ÉCHANGEABLE POUR RÉPARATION MINI-INVASIVE À C UR BATTANT DE FEUILLETS DE VALVE CARDIAQUE

(84) Designated Contracting States:

AL AT BE BG CH CY CZ DE DK EE ES FI FR GB GR HR HU IE IS IT LI LT LU LV MC MK MT NL NO PL PT RO RS SE SI SK SM TR

(30) Priority: **29.12.2010 US 201061428048 P**

(43) Date of publication of application:

06.11.2013 Bulletin 2013/45

(73) Proprietor: **Neochord Inc.**

Minnetonka, MN 55343 (US)

(72) Inventors:

- **ZENTGRAF, John**
Minnetonka, MN 55343 (US)
- **PARINS, David, Joseph**
Minnetonka, MN 55343 (US)

- **SAINI, Arun**
Minnetonka, MN 55343 (US)

(74) Representative: **Harris, Oliver John Richard et al**

Novagraaf UK
Centrum
Norwich Research Park
Colney Lane
Norwich NR4 7UG (GB)

(56) References cited:

WO-A2-2006/078694	WO-A2-2008/112237
DE-U1-202004 017 888	US-A- 5 053 013
US-A- 5 766 163	US-A1- 2004 116 767
US-A1- 2004 167 539	US-A1- 2006 074 484
US-A1- 2007 049 952	US-A1- 2008 188 873
US-A1- 2009 105 729	US-A1- 2009 105 729
US-A1- 2010 160 726	US-B1- 7 635 386

EP 2 658 480 B1

Note: Within nine months of the publication of the mention of the grant of the European patent in the European Patent Bulletin, any person may give notice to the European Patent Office of opposition to that patent, in accordance with the Implementing Regulations. Notice of opposition shall not be deemed to have been filed until the opposition fee has been paid. (Art. 99(1) European Patent Convention).

DescriptionFIELD OF THE INVENTION

[0001] The present invention relates to a system for minimally invasive repair of a heart valve. More particularly, the present invention relates to an exchangeable system for minimally invasive repair of heart valves that allows for multiple repair devices to be deployed with a single access into the heart that permit the repairs to be done on a beating heart without the need for cardiopulmonary bypass and open heart access to the heart.

BACKGROUND OF THE INVENTION

[0002] Various types of surgical procedures are currently performed to investigate, diagnose, and treat diseases of the heart and the great vessels of the thorax. Such procedures include repair and replacement of mitral, aortic, and other heart valves, repair of atrial and ventricular septal defects, pulmonary thrombectomy, treatment of aneurysms, electrophysiological mapping and ablation of the myocardium, and other procedures in which interventional devices are introduced into the interior of the heart or a great vessel.

[0003] Using current techniques, many of these procedures require a gross thoracotomy, usually in the form of a median sternotomy, to gain access into the patient's thoracic cavity. A saw or other cutting instrument is used to cut the sternum longitudinally, allowing two opposing halves of the anterior or ventral portion of the rib cage to be spread apart. A large opening into the thoracic cavity is thus created, through which the surgical team may directly visualize and operate upon the heart and other thoracic contents.

[0004] Surgical intervention within the heart generally requires isolation of the heart and coronary blood vessels from the remainder of the arterial system, and arrest of cardiac function. Usually, the heart is isolated from the arterial system by introducing an external aortic cross-clamp through a sternotomy and applying it to the aorta between the brachiocephalic artery and the coronary ostia. Cardioplegic fluid is then injected into the coronary arteries, either directly into the coronary ostia or through a puncture in the aortic root, so as to arrest cardiac function. In some cases, cardioplegic fluid is injected into the coronary sinus for retrograde perfusion of the myocardium. The patient is placed on cardiopulmonary bypass to maintain peripheral circulation of oxygenated blood.

[0005] Of particular interest are intracardiac procedures for surgical treatment of heart valves, especially the mitral and aortic valves. According to recent estimates, more than 79,000 patients are diagnosed with aortic and mitral valve disease in U.S. hospitals each year. More than 49,000 mitral valve or aortic valve replacement procedures are performed annually in the U.S., along with a significant number of heart valve repair procedures.

[0006] Various surgical techniques may be used to repair a diseased or damaged valve, including annuloplasty (contracting the valve annulus), quadrangular resection (narrowing the valve leaflets), commissurotomy (cutting the valve commissures to separate the valve leaflets), shortening mitral or tricuspid valve chordae tendonae, reattachment of severed mitral or tricuspid valve chordae tendonae or papillary muscle tissue, and decalcification of valve and annulus tissue. Alternatively, the valve may be replaced by excising the valve leaflets of the natural valve and securing a replacement valve in the valve position, usually by suturing the replacement valve to the natural valve annulus. Various types of replacement valves are in current use, including mechanical and biological prostheses, homografts, and allografts.

[0007] The mitral valve, located between the left atrium and left ventricle of the heart, is most easily reached through the wall of the left atrium, which normally resides on the posterior side of the heart, opposite the side of the heart that is exposed by a median sternotomy. Therefore, to access the mitral valve via a sternotomy, the heart is rotated to bring the left atrium into a position accessible through the sternotomy. An opening, or atriotomy, is then made in the left atrium, anterior to the right pulmonary veins. The atriotomy is retracted by means of sutures or a retraction device, exposing the mitral valve directly posterior to the atriotomy. One of the aforementioned techniques may then be used to repair or replace the valve.

[0008] An alternative technique for mitral valve access may be used when a median sternotomy and/or rotational manipulation of the heart are/is undesirable. In this technique, a large incision is made in the right lateral side of the chest, usually in the region of the fifth intercostal space. One or more ribs may be removed from the patient, and other ribs near the incision are retracted outward to create a large opening onto the thoracic cavity. The left atrium is then exposed on the posterior side of the heart, and an atriotomy is formed in the wall of the left atrium, through which the mitral valve may be accessed for repair or replacement.

[0009] The mitral and tricuspid valves inside the human heart include an orifice (annulus), two (for the mitral) or three (for the tricuspid) leaflets and a subvalvular apparatus. The subvalvular apparatus includes multiple chordae tendineae, which connect the mobile valve leaflets to muscular structures (papillary muscles) inside the ventricles. Rupture or elongation of the chordae tendineae result in partial or generalized leaflet prolapse, which causes mitral (or tricuspid) valve regurgitation. A commonly used technique to surgically correct mitral valve regurgitation is the implantation of artificial chordae (usually 4-0 or 5-0 Gore-Tex sutures) between the prolapsing segment of the valve and the papillary muscle. This operation is generally carried out through a median sternotomy and requires cardiopulmonary bypass with aortic cross-clamp and cardioplegic arrest of the heart.

[0010] Using such open-chest techniques, the large opening provided by a median sternotomy or right tho-

racotomy enables the surgeon to see the mitral valve directly through the left atriotomy, and to position his or her hands within the thoracic cavity in close proximity to the exterior of the heart for manipulation of surgical instruments, removal of excised tissue, and/or introduction of a replacement valve through the atriotomy for attachment within the heart. However, these invasive open-chest procedures produce a high degree of trauma, a significant risk of complications, an extended hospital stay, and a painful recovery period for the patient. Moreover, while heart valve surgery produces beneficial results for many patients, numerous others who might benefit from such surgery are unable or unwilling to undergo the trauma and risks of current techniques.

[0011] One alternative to open heart surgery is a robotically guided, thoroscopically assisted cardiomyotomy procedure marketed under the tradename of the DaVinci® system. Instead of requiring a sternotomy, the DaVinci® system uses a minimally invasive approach guided by camera visualization and robotic techniques. Unfortunately, the DaVinci® system is not approved for mitral valve repair procedures on a beating heart. Thus, the use of the DaVinci® system for mitral valve repair still requires a cardiopulmonary bypass with aortic cross-clamp and cardioplegic arrest of the heart.

[0012] While there are other laparoscopic and minimally invasive surgical techniques and tools that have been developed, most of these devices are not useable for the unique requirements of mitral valve repair on a beating heart. Suturing devices like the Superstich™ vascular suturing device or the Gore® suture passer are designed to permit manual placement of sutures as part of a surgical procedure, but are not designed for use on a beating heart. While certain annuloplasty techniques and instruments that can suture an annuloplasty ring as part of vascular repair or heart bypass surgery may be used in conjunction with a beating heart, these annuloplasty procedures do not involve the capture or retention of a constantly moving leaflet. Consequently, the design and use of annuloplasty techniques and instruments are of little help in solving the problems of developing instruments and techniques for minimally invasive thoroscopic repair of heart valves.

[0013] Recently, a technique has been developed for minimally invasive thoroscopic repair of heart valves while the heart is still beating. PCT Pub. No. WO 2006/078694 A2 to Speziali discloses a thoroscopic heart valve repair method and apparatus. Instead of requiring open heart surgery on a stopped heart, the thoroscopic heart valve repair methods and apparatus taught by Speziali utilize fiber optic technology in conjunction with transesophageal echocardiography (TEE) as a visualization technique during a minimally invasive surgical procedure that can be utilized on a beating heart. U.S. Publication No. 2008/0228223 to Alkhatib also discloses a similar apparatus for attaching a prosthetic tether between a leaflet of a patient's heart valve and another portion of the patient's heart to help prevent prolapse of

the leaflet and/or to otherwise improve leaflet function.

[0014] More recent versions of these techniques are disclosed in U.S. Patent Application Publication Nos. 2009/0105751 and 2009/0105729 to Zentgraf, which disclose an integrated device that can enter the heart chamber, navigate to the leaflet, capture the leaflet, confirm proper capture, and deliver a suture as part of a mitral valve regurgitation (MR) repair.

[0015] While the Speziali and Zentgraf techniques represent a significant advance over open heart techniques and previous minimally invasive techniques for heart valve repair, it would be advantageous to further improve upon these techniques. US Patent No. 7,635,386 to Gammie discloses a system for repairing a heart valve, comprising: a port adapted to span a wall of the heart of the patient, the port having an opening extending there-through configured to provide access to the interior of the heart; a catheter slidably insertable into the opening of the port, the catheter including a deployment mechanism, and a distal end that forms a first portion of a jaw assembly adapted to grasp target tissue for repair in the heart; a repair cartridge slidably insertable into the catheter, the repair cartridge carrying a repair device configured to be deployed into the target tissue in conjunction with the deployment mechanism, and having a shaft with a tip at a distal end of the shaft that forms a second portion of the jaw assembly; and a seal positioned within the opening of the port, the seal adapted to substantially prevent blood from escaping the heart through the port while providing for selective insertion and removal of the catheter and repair cartridge through the port.

SUMMARY OF THE INVENTION

[0016] The present invention is defined by the features of independent claim 1. Preferred embodiments are defined by the dependent claims.

BRIEF DESCRIPTION OF THE FIGURES

[0017] The invention may be more completely understood in consideration of the following detailed description in connection with the accompanying drawings, in which:

Figure 1A is a perspective view of a heart valve repair system according to an embodiment of the present invention.

Figure 1B is an exploded view of the heart valve repair system of Figure 1A.

Figure 1C is a partial view of the heart valve repair system of Figure 1A.

Figure 1D is a perspective view of the heart valve repair system of Figure 1A.

Figure 2A is an exploded view of a port for a heart valve repair system according to an embodiment of the present invention.

Figure 2B is a perspective view of a port for a heart

valve repair system according to an embodiment of the present invention.

Figure 2C is a perspective view of a port for a heart valve repair system according to an embodiment of the present invention.

Figure 2D is an exploded view of a port for a heart valve repair system according to an embodiment of the present invention.

Figure 2E is a perspective view of a portion of the port of Figure 2D.

Figure 3 is a flowchart of steps in a method of repairing a heart valve.

Figure 4A is a schematic representation of a step in a method of repairing a heart valve.

Figure 4B is a schematic representation of a step in a method of repairing a heart valve.

Figure 5 is a partial side view of a heart valve repair system according to an embodiment of the present invention.

Figure 6 is a schematic representation of a step in a method of repairing a heart valve.

Figure 7 is a schematic representation of a step in a method of repairing a heart valve.

Figure 8 is a schematic representation of a step in a method of repairing a heart valve.

Figure 9 is a partial side view of a heart valve repair system according to an embodiment of the present invention.

Figure 10A is a partial side view of a heart valve repair system according to an embodiment of the present invention.

Figure 10B is a partial side view of a heart valve repair system according to an embodiment of the present invention.

Figure 11 is a partial perspective view of a heart valve repair system according to an embodiment of the present invention.

Figure 12 is a partial side view of a heart valve repair system according to an embodiment of the present invention.

Figure 13A is a top view of a portion of a heart valve repair system according to an embodiment of the present invention.

Figure 13B is a top view of the portion of a heart valve repair system of Figure 13A.

Figure 13C is a top view of the portion of a heart valve repair system of Figure 13A.

Figure 13D is a top view of the portion of a heart valve repair system of Figure 13A.

Figure 14 is a schematic representation of a portion of a heart valve repair system.

Figure 15 is a partial perspective view of a portion of a heart valve repair system.

[0018] While the invention is amenable to various modifications and alternative forms, specifics thereof have been shown by way of example in the drawings and will be described in detail. It should be understood, however,

that the intention is not to limit the invention to the particular embodiments described. On the contrary, the intention is to cover all modifications, equivalents, and alternatives falling within the scope of the invention.

5

DETAILED DESCRIPTION

[0019] In the following detailed description of the present invention, numerous specific details are set forth in order to provide a thorough understanding of the present invention. However, one skilled in the art will recognize that the present invention may be practiced without these specific details. In other instances, well-known methods, procedures, and components have not been described in detail so as to not unnecessarily obscure aspects of the present invention.

[0020] Embodiments of the present disclosure define a system that provides access into a heart chamber to repair a heart valve or other tissue structure while the heart is still beating and while minimizing the loss of blood with and without the system inserted. In one embodiment, the heart chamber is accessed transapically via thoracotomy followed by a ventriculotomy. The heart apex can initially be visualized directly through the thoracotomy or can be captured with a capture funnel which expands/unfolds until generally shaped like a conical funnel used to center, hold, and isolate the heart apex for incision. In other embodiments, the apex is visualized via an Ultrasound or IVUS system or via any other non-invasive imaging technique, such as, for example, fluoroscopy or magnetic or radio-frequency tracking.

[0021] Once access into the heart chamber is achieved, the system is navigatable via a non-invasive imaging modality. The system provides for capture of intra-cardiac tissue structure. Once captured, the system allows control to be maintained over said tissue structure. Using a device-based imaging component, the system allows confirmation of proper capture position of the system relative to the tissue structure. The system then accommodates the delivery of a repair device to said tissue structure to reduce/eliminate mitral valve regurgitation or other defect once proper position has been confirmed. Tissue structure, as used herein, can refer to any intracardiac structure that is a site for repair or anchoring, such as, for example, valve leaflets, papillary muscles or the heart wall. A repair device is any device whose function is to repair or replace a tissue structure, such as, for example, a suture.

[0022] An exchangeable heart valve repair system 100 for accomplishing the above described procedure is depicted in Figures 1A-1D. System 100 includes a suture cartridge 102 or other repair device, a deployment catheter 104, a fiber optic shaft 106, a port 108 and a locking mechanism 110. Fiber optic shaft 106 can communicate with a display (not pictured). A handle for guiding the device can be connected to a proximal end of system.

[0023] The fiber optic shaft or imaging catheter 106 comprises an elongate shaft that can contain device-

based imaging, such as fiber optics or sensors. In one embodiment, fiber optics are carried within dedicated lumens 112 in an outer wall 114 of fiber optic shaft 106. Device based imaging can transmit an image to display that is used to confirm proper position on the tissue structure. In one embodiment, display will confirm whether there is full (proper) or partial or no (improper) tissue structure capture. Fiber optic shaft 106 also defines a lumen that allows passage of the deployment catheter 104.

[0024] Fiber optic shaft 106, also referred to more generally as an imaging catheter, can comprise individual optical fibers, bundled, within the wall thickness 114 and terminating flush at the distal tip of the catheter 106. In one embodiment, the optical fibers are evenly spaced around the circumference of the imaging catheter 106. In another embodiment, the optic fibers 106 are evenly spaced around the "top" semicircular arc of the catheter 106 relative to the suture cartridge 102. Device-based imaging can include one or more of, but is not limited to, fiber optics, a scope, ICE, OCT, Opto/Acoustic, IVUS, infrared and sonar. In one embodiment, system 100 does not employ a device-based imaging component.

[0025] The deployment catheter 104 is used to position and deploy a repair device, such as a suture, to the tissue structure, such as a valve leaflet. The deployment catheter 104 includes a shaft 116 having a proximal end 118 and a distal end 120 which is inserted into the lumen of the fiber optic shaft 106. The deployment catheter 104 can have an interference fit in the lumen of the fiber optic shaft 106 in order to retain the catheter 104 within the shaft 106 during the procedure. Alternatively, the lumen of the fiber optic shaft 106 can include a rib or other structure over which the deployment catheter 104 is advanced to provide a snap fit holding the catheter 104 within the shaft 106. A deployment mechanism such as a needle is slidably disposed in a needle lumen 122 extending through deployment catheter 104 for penetrating the valve leaflet to insert a suture. The deployment catheter 104 also includes a cartridge lumen 124 adapted to slidably contain the suture cartridge 102.

[0026] The suture cartridge 102 is loaded into the cartridge lumen 124 of deployment catheter 104 and forms a part of the deployment catheter 104. Suture cartridge 102 includes a shaft 126 and a tip 128. The suture cartridge 102 can contain some or all of a suture or other repair device used to repair tissue. The suture cartridge 102 and deployment catheter 104 operate together to form clamping jaws for grasping tissue such as a valve leaflet therebetween. Tip 128 of suture cartridge 102 is movable relative to deployment catheter 104 by sliding the suture cartridge 102 within the cartridge lumen 124 of deployment catheter 104. A proximally facing surface 130 of the tip 128 and a distally facing surface 132 of the deployment catheter 104 each operate as a portion of the clamping jaws for grasping tissue therebetween. Once tissue is grasped between the jaws, the repair device can be deployed with the deployment mechanism,

such as by a needle penetrating the tissue to insert a suture. Details of various embodiments relating to tissue capture and repair device deployment are disclosed in PCT Pub. No. WO 2006/078694 A2 to Speziali and U.S. Patent Application Publication Nos. 2009/0105751 and 2009/0105729 to Zentgraf. The port 108, shown in more detail in Figure 2A, is positioned to span the heart muscle wall and is stabilized in that position during the procedure. Port 108 can include a stabilizing portion 134 and a sealing portion 136 and has an opening 139 extending through both portions between an interior and an exterior of the heart. In some embodiments, stabilizing portion 134 can include additional stabilizing structure, such as threads 137 as shown in Figure 2B or ribs to increase stability of the port 108 in the heart wall. In an embodiment depicted in Figure 2C, port 108 includes a circumferential groove 133 that defines a narrower central portion 135 around which the heart naturally constricts to provide further stability. In one embodiment, port 108 can comprise a soft material to allow the heart wall to compress into/around it to provide increased stabilization. Port 108 can be flexible to accommodate the insertion of pre-formed, canted shaft/tip shapes (e.g. shaped stylets) and other elements for the advancing/securing of knots (e.g. a knot pusher). Port 108 eliminates the need for multiple passes of the instrument directly against the heart muscle, minimizes blood loss due to instrument leakage and reduces push/pull forces on the heart wall. In an alternative embodiment, system 100 does not employ a port 108.

[0027] Port 108 can include one or more seals 138, 140 in sealing portion 136 to maintain hemostasis with and without an instrument inserted to allow multiple exchanges of tools in the heart chamber while minimizing blood loss. A first seal 138 can include an opening 142 designed to seal around an inserted instrument to maintain hemostasis with the instrument inserted. In one embodiment, the opening 142 is oblong to accommodate a shaft of a similarly shaped instrument. In another embodiment, the opening 142 is symmetrically circular to accommodate an instrument with a shaft of a matching shape. Such a configuration allows the instrument to be circumferentially rotated following insertion. A second seal 140 can be used to maintain hemostasis when no instrument is inserted. Seals 138, 140 can include slits 144. In addition to allowing an instrument to pass through the seals 138, 140, each slit 144 can secure a suture or similar repair device and hold it out of the way of the procedure while also limiting risk of unintentional tension exerted onto the suture. When multiple sutures are inserted, each can be held in a slit 144 to prevent tangling of the sutures with each other or on successive passes of the instrument. In one embodiment, seal 140 can include suture retention projections 143 that include suture grooves 147 that can extend partially or completely through projections 143 for enhanced suture retention. In such an embodiment, seal 138 can include apertures 145 for accommodating suture retention projections 143. The system 100 can therefore control and accommodate

multiple deployed repair devices from interfering with the subsequent deployment of more repair devices. In one embodiment, the seals 138, 140 are fixed in place relative to port 108. In another embodiment, the seals 138, 140 are free to rotate and/or move linearly within sealing portion 136.

[0028] A handle can be connected to a proximal end of the device 100 to allow control over the device position, jaw actuation, and repair device deployment. In one embodiment, each deployment catheter 104 and/or suture cartridge 102 includes a separate handle that is removed and exchanged when the catheter 104 or cartridge 102 is removed. In another embodiment, the system 100 includes a single handle to which multiple deployment catheters 104 or suture cartridges 102 are exchangeable and attachable. Handle can provide for manual or automatic actuation of the deployment mechanism for the repair device.

[0029] A display can be communicatively coupled to the system to receive the images and/or other information captured by device-based imaging. In one embodiment, a cable connects the fiber optic shaft 106 and display. In another embodiment, display wirelessly communicates with the system 100 to obtain the observed data. Display can be an integrated display of system or standard OR monitors. An integrated display can be included as part of the handle. Alternatively, display can be projected onto a location convenient for the physician (e.g. wall, head-up display, etc.). In some embodiments, display can provide, in addition to or in lieu of visual feedback, auditory or tactile feedback.

[0030] The removable locking mechanism 110 locks the port 108 and fiber optic shaft or imaging catheter 106 relative to each other, which holds the tip 128 and the fiber optic shaft 106 in proper position for penetration into the heart muscle. Thus, as force is exerted by the physician from a proximal end of the system 100 into the heart wall with the distal end of the system 100, the suture cartridge 102, deployment catheter 104, fiber optic shaft 106 and port 108 remain stationary with respect to each other as the heart is penetrated and the device remains stiff to allow insertion into the heart. In one embodiment, removable locking mechanism 110 holds the components in place via an interference fit. In another embodiment, removable locking mechanism 110 utilizes a snap fit. When removable locking mechanism 110 is removed, as in Figure 1D, fiber optic shaft 106 (and with it deployment catheter 104 and suture cartridge 102) are able to slide forwardly relative to port 108 in order to access the repair site. In one embodiment, removable locking mechanism 110 is rigid.

[0031] Removable locking mechanism 110 can include a projection or fin 111 that aids in removal of locking mechanism 110. In one embodiment, fin 111 is rigid and unitary with locking mechanism 110. Alternatively, fin 111 can be retractable via, for example, a spring mechanism to reduce the profile of locking mechanism 110 when desired. In other embodiments, removable locking mech-

anism 110 can be removable with a separate removal tool, such as a magnetic removal tool that cooperates with a magnet in locking mechanism 110 or a removal tool that is keyed to fit into and mate with a recess in locking mechanism. The length of locking mechanism 110 can be used to control a distance that the imaging catheter 116 and tip 128 extend from the port 108 during insertion. Typically, it is desirable to minimize this distance.

[0032] In one embodiment, tip 128 of suture cartridge 102 is provided with a tapered configuration in order to ease entrance through and dilate the opening in the heart wall. Such a configuration reduces the insertion force necessary for entrance into the heart wall and the port 108. Alternatively, system 100 can employ a separate trocar to penetrate the incision and seat port 109, which is then removed and replaced with imaging catheter 106. In one embodiment, tip 128 and shaft 126 of suture cartridge 102 and distal end 120 of fiber optic shaft 106 and deployment catheter 104 extend generally straight outwardly from system 100 as shown in Figure 5. In another embodiment, distal end 120 has a pre-formed and permanent curve to allow access to difficult and hard to reach areas of the heart chamber 14 as shown in Figure 6. Distal end 120 can also be flexible as shown in Figure 7 to allow it to conform to the shape of pre-formed stylets 146 to guide fiber optic shaft 106 and deployment catheter 104 along a predefined path. In a further embodiment, distal end 120 can be capable of articulating between various angular positions as shown in Figure 8 to allow it to adapt to various insertion geometries.

[0033] The flowchart depicted in Figure 3 shows the steps of a surgical procedure 200 utilizing exchangeable repair system 100 according to an embodiment of the present invention. In preparation for the initial insertion of the system into the heart chamber, the components are assembled and removable locking mechanism locks the fiber optic shaft 106 and port 108 in place relative to each other at step 202. The locked assembly is then advanced as a unit penetrating into the heart 10 through a heart wall 12 and into a heart chamber 14 at step 204 as shown in Figure 4A. The left ventricle is accessed via port 108 to facilitate entrance of the system 100 into the heart chamber. The lock is then removed at step 206 to allow the fiber optic shaft 106 to slide relative to the port 108 as needed.

[0034] The cartridge 102 slides in a dedicated lumen 124 inside of the deployment catheter 104. The deployment catheter 104 can slide in a dedicated lumen inside of the fiber optic shaft 106, but can remain generally in place during the procedure due to an interference fit or other structure retaining the deployment catheter 104 in the fiber optic shaft 106. The fiber optic shaft 106 slides in a dedicated lumen inside of the port 108. The port 108 maintains the access into the heart chamber 14 and remains seated in the heart wall 12 as the other components are selectively moved relative to the port 108. At step 208, the deployment catheter 104, suture cartridge

102 and fiber optic shaft 106 can be advanced to a tissue structure 16 to capture the tissue structure 16 with the clamping jaws. Device-based imaging present in the fiber optic shaft 106 is used to confirm proper tissue capture at step 210. A repair device, such as a suture, can be deployed onto the tissue at step 212. The deployment catheter 104 and/or suture cartridge 102 can then be removed and a new deployment catheter 104, suture cartridge 102 or other repair device can be inserted a desired number of times to deploy additional repair devices at step 214. The deployment catheter 104 can be exchanged with or without the fiber optic shaft 106. Tools having various functions and/or employing various repair devices can be used interchangeably with system 100 by insertion into fiber optic shaft 106.

[0035] In one embodiment, the port 108 has an inner diameter of approximately 32 french, the fiber optic shaft has an outer diameter of 28 french, the deployment catheter has an outer diameter of 24 french, and the repair cartridge 102 shaft 126 has an outer diameter of 5 french. The removable locking mechanism can have a height of about 5 french.

[0036] System 100 can be utilized in conjunction with non-invasive imaging distinct from the device-based imaging for confirmation capture in order to further enhance visualization and positioning of the system inside the heart. Non-invasive imaging refers to imaging modalities that are independent of the device and are used for global navigation of the device inside the heart. In one embodiment, the system 100 can be guided when inside the heart via TEE (Transesophageal Echo - 2D and 3D). In another embodiment, the system 100 is guided via real-time MRI. In other embodiments, the system 100 can be guided using fluoroscopy, infrared or sonar. In an embodiment, no external non-invasive imaging is needed.

[0037] Device-based imaging is used by system 100 to precisely locate the deployment catheter 104 and fiber optic shaft or imaging catheter 106 on the target zone of the tissue structure. Device-based imaging can be carried by a separate fiber optic shaft or independent imaging catheter 106 or be incorporated into the deployment catheter 104.

[0038] In one embodiment, the device-based imaging is integrated into the deployment catheter 104 via a plurality of channels 148 carrying imaging elements to the distal end of the catheter as shown in Figure 9. Capture of the tissue structure simultaneously results in indication of proper capture. When proper capture has been achieved, the repair device can be deployed.

[0039] In other embodiments, the device-based imaging is independent of the deployment catheter 104. One embodiment is depicted in Figures 10A and 10B. The system 100 is inserted into the heart chamber with the independent imaging catheter or fiber optic shaft 106 inserted comprising the proximal face of the clamp that is formed with the suture cartridge 102. Capture of the tissue structure simultaneously results in indication of proper capture. When proper capture has been achieved, the

independent imaging catheter 106 is retracted (intermediate proximal clamp surface may be used or the outer sheath 105 may be used to maintain control of the tissue structure). The deployment catheter 104 is then inserted and the repair device can be deployed. Figure 11 depicts an additional embodiment wherein a deployment sheath 105 defines a lumen 124 for the suture cartridge 102 and a separate lumen 150 that can separately carry the imaging catheter 106 and the deployment catheter 104 carrying the repair device. Suture cartridge 102 can include an opening 152 to enhance visualization through tip 128. In some embodiments, following deployment of the repair device, the deployment catheter 104 can be removed and the imaging catheter 106 reinserted to visualize/confirm effectiveness of the deployed repair device. In an embodiment, the same independent imaging catheter and deployment catheter can be reused wherein said deployment catheter is reloaded with new repair devices. In a further embodiment, the deployment catheter is disposable after a single use. Each new repair device is then loaded in a new deployment catheter.

[0040] Device-based imaging can also be linked to the deployment catheter 104 as described previously herein with reference to Figures 1A-1D and as further illustrated in Figure 12. The system 100 enters the heart chamber with the linked imaging catheter 106 inserted comprising the proximal face of the clamp. The linked imaging catheter 106 and port 108 are locked together for puncture access into the heart chamber. The system can then be unlocked allowing the imaging catheter 106 to move independently in and out of the port 108. Capture of the tissue structure simultaneously results in indication of proper capture. When proper capture has been achieved, the repair device can be deployed. The deployment catheter 104 can be retracted leaving the linked imaging catheter 106 in place. The linked imaging catheter 106 and deployment catheter 104 can also be removed together as one. Multiple repair devices can be deployed in this manner with the port 108 maintaining a seal and allowing different repair devices to be deployed. In one embodiment, the same deployment catheter 104 can be reused by being reloaded with new repair devices. In another embodiment, the deployment catheter 104 is disposable after a single use and each new repair device is loaded in an individual deployment catheter 104.

[0041] In another embodiment of the deployment catheter 104 and cartridge 102 tip 128, multiple sets of clamps may be used, e.g., a secondary clamp composed of a retractable/collapsible wire form can be used for gross capture of the tissue structure and a primary clamp can then be used for finer precision. The primary clamp can be positioned and repositioned as desired while the secondary clamp prevents total loss of control of the tissue structure. In another embodiment shown in Figure 15, a single clamp can incorporate a rolling mechanism 180. Said mechanism can be spring loaded, or loaded in a similar fashion, such that as the clamps are opened to reposition, the rolling mechanism protrudes, keeping

contact/control of the tissue structure, but allowing repositioning. As the clamps are closed, the rolling mechanism is retracted into the tip 128 and does not interfere with clamp closure.

[0042] In one embodiment shown in Figure 14, the clamp face of tip 128 and/or deployment catheter 104 is embedded with micro-needles 182 for drug delivery. The drug delivered could aid in tissue growth on/through the repair device. The drug could also alter the composition of the leaflet, such as by tightening the leaflet to reduce mitral valve regurgitation (such that the drug acts as the repair device).

[0043] System 100 can be designed to load and deploy a single repair device. Alternatively, multiple repair devices can be loaded at one time and deployed simultaneously or in series. In such an embodiment, multiple repair devices can be deployed without withdrawing the deployment catheter 104 far away from the target or out of the heart completely. In one embodiment, the deployment action of a first repair device is linked to the loading action of a second repair device. In some embodiments, multiple sutures can be used on the same leaflet. Multiple sutures on both leaflets can be used and tethered together to create an edge-to-edge repair.

[0044] The repair device delivered by the system can be a suture that is delivered through the leaflet and secured with a girth hitch knot. The suture can then be tensioned to reduce mitral valve regurgitation and anchored to the exterior of the heart apex. The suture can alternatively be anchored to the papillary muscle, to the heart wall (i.e., more lateral relative to the apex) or to a leaflet of another heart valve (e.g., a mitral valve leaflet tethered to an aortic valve leaflet). Alternatively, other securing methods can be used including alternative knots, use of a knot pusher, the creation and advancement of the knot from the exterior of the heart, the creation/advancement of the knot while inside the heart chamber, and the use of an attachment clip.

[0045] The suture can be captured by a deployment mechanism (e.g. a hooked needle) with a single capture area. In another embodiment, a deployment mechanism can have redundant capture points (e.g. a needle with multiple hooks or a corkscrew shape). In a further embodiment, a key and lock mechanism can be used wherein the deployment mechanism locks into a key mechanism that is connected to the suture. Alternatively, the suture is used to capture the deployment mechanism (e.g. the suture is held open in a lasso formation, the hook is passed through, the lasso is closed around the hook, and then the hook is retracted). In one embodiment, the deployment mechanism can have a retractable/collapsible capture end (e.g. the tip closes similar to an umbrella and the tip is passed by the suture in the closed position, opened, retracted to the suture, and closed around the suture).

[0046] In some embodiments, sutures 160 can be anchored with the use of a pledget 162 as shown in Figures 13A-13D. Pledgets 162 typically comprise a thin soft ma-

terial, such as, for example, teflon. Pledget 162 defines a body 164 having one or more apertures 166 extending through body 164. In one embodiment, pledget 162 has three apertures 166A, 166B, 166C. Following deployment of the suture 160 onto a tissue structure, a first free end 168 and a second free end 170 of the suture can be passed through the pledget apertures 166A-C. In one embodiment, free ends 168, 170 are passed through pledget 162 as shown in Figures 13A and 13B in the direction and order indicated by the arrows. First free end 168 of suture 160 is threaded up through second aperture 166B, down through third aperture 166C and then back up through first aperture 166A. Second free end 170 is also threaded up through second aperture 166B and then down through first aperture 166A and back up through third aperture 166C. Free ends 168, 170 can then be used to form a knot 172 as shown in Figure 13C. In one embodiment, pledget 162 does not have apertures 166 and instead suture 160 is threaded through pledget with a needle or other penetrating device. A retrieval suture 174 that can be comprised of, for example, prolene, can then be threaded through the pledget 162 as shown in Figure 13D. The pledget 162 and suture 160 can be inserted into the heart chamber by using a blunt end forceps or similar instrument to pass the knot 172 into the chamber approximately mid-way to the valve. Once in the chamber, the knot 172 can be released and the suture 160 and pledget 162 can be delivered to the tissue structure by pulling on the loop end of the suture 160. In one embodiment, multiple sutures on one or both leaflets can be tied to the same pledget 162.

[0047] Port 108 can include additional features to aid in use of a pledget 162 or other repair device. Port 108 can include structure that moves and holds tissue structures, such as muscle, tendinae and connective tissue, at the insertion point out of the way to ease insertion of a repair device well into the open space of the heart chamber to limit snagging of the repair device on the tissue during insertion. Alternatively, port 108 can include an insertion channel that extends well into the heart chamber to allow the repair device to be inserted into the open area of the heart beyond said tissue. In addition, port 108 can utilize structure to aid in retrieving and removing a repair device to limit interference with retrieval of the device back out of the heart chamber.

[0048] Various embodiments of systems, devices and methods have been described herein. These embodiments are given only by way of example and are not intended to limit the scope of the present invention. It should be appreciated, moreover, that the various features of the embodiments that have been described may be combined in various ways to produce numerous additional embodiments. Moreover, while various materials, dimensions, shapes, implantation locations, etc. have been described for use with disclosed embodiments, others besides those disclosed may be utilized without exceeding the scope of the invention.

Claims

1. A system for repairing a heart valve in a beating heart of a patient, comprising:

a port (108) adapted to span a wall of the heart of the patient, the port (108) having an opening (139) extending therethrough configured to provide access to the interior of the heart, and a proximally facing surface; a catheter (104; 106) slidably insertable into the opening (139) of the port (108), the catheter (104; 106) including at least one imaging element and a deployment mechanism and the catheter further having a proximal portion that is raised relative to the outer surface of the catheter, the proximal portion comprising a distally facing surface, and a distal end (120) that forms a first portion of a jaw assembly adapted to grasp target tissue for repair in the heart;

a repair cartridge (102) slidably insertable into the catheter (104; 106), the repair cartridge (102) carrying a repair device that can be deployed into the target tissue in conjunction with the deployment mechanism and having a shaft (126) with a tip (128) at a distal end of the shaft (126) that forms a second portion of the jaw assembly, wherein the imaging element is configured to confirm proper capture of the target tissue with the jaw assembly;

an elongate removable locking mechanism (110) configured to engage with the catheter (104; 106) longitudinally along a length of an outer circumferential surface of the catheter (104; 106), and thus provide a physical barrier sandwiched between the proximally facing surface of the port and the distally facing surface of the catheter (104; 106) to prevent the catheter (104; 106) from moving distally relative to the port (108), and furthermore configured to be removable from contact with both the catheter (104; 106) and the port (108), so that the catheter is free to slide distally relative to the port (108); and a seal (138; 140) positioned within the opening (139) of the port (108), the seal (138; 140) adapted to substantially prevent blood from escaping the heart through the port (108) while providing for selective insertion and removal of the catheter (104; 106) and repair cartridge (102) through the port (108) while the heart of the patient is beating.

2. The system of claim 1, wherein the catheter (104; 106) comprises an imaging catheter (106) carrying the imaging element and a separate deployment catheter (104) carrying the deployment mechanism.

3. The system of claim 2, wherein the deployment cath-

eter (104) is slidably insertable into a lumen of the imaging catheter (106).

4. The system of claim 2, wherein the deployment catheter (104) and imaging catheter (106) are selectively insertable into a common lumen in the catheter (104; 106).

5. The system of claim 2, further comprising a second repair cartridge at least partially carrying a second repair device, the second repair cartridge adapted to replace the repair cartridge (102) in the system following deployment of the repair device.

6. The system of claim 5, further comprising a second deployment catheter, wherein the second repair cartridge is insertable into the second deployment catheter.

7. The system of claim 1, wherein the repair device is a suture.

8. The system of claim 7, further comprising a pledget (162) to which the suture can be attached following deployment of the suture, the pledget (162) adapted to directly interface with the target tissue.

9. The system of claim 1, wherein the at least one seal (138; 140) includes at least a first seal (138) and a second seal (140), the first seal (138) having an opening (142) adapted to seal around an outer surface of the catheter (104; 106) and the second seal (140) having a plurality of slits (144) that remain generally sealed when the catheter (104; 106) is not inserted through the second seal (140).

10. The system of claim 1, wherein the at least one imaging element comprises a plurality of fiber optics carried within at least one dedicated lumen (112) in the imaging catheter (106).

11. The system of claim 1, wherein the tip of the repair cartridge (102) has a tapered distal end.

12. The system of claim 1, wherein the port (108) includes a stabilizing portion (134) that can engage with and seal with the heart wall and extend into the heart to provide access to the interior of the heart through the port (108).

13. A method of providing systems and instructions for repairing a valve comprising:

providing any of the systems of claims 1-13; and providing instructions for operating the systems of claims 1-13 to repair the valve.

Patentansprüche

1. System für Reparatur einer Herzklappe in einem schlagenden Herzen eines Patienten, wobei das System Folgendes aufweist:

einen Durchlass (108), der angepasst ist, um eine Wand des Herzens des Patienten zu überspannen, wobei der Durchlass (108) eine sich durch diesen erstreckende Öffnung (139), die für Bereitstellen eines Zugangs zum Inneren des Herzens konfiguriert ist, und eine proximale Stirnfläche aufweist;

einen Katheter (104; 106), der gleitbar in die Öffnung (139) des Durchlasses (108) einsetzbar ist, wobei der Katheter (104; 106) mindestens ein Bilderzeugungselement und einen Entfaltungsmechanismus aufweist und der Katheter ferner einen im Verhältnis zur äußeren Oberfläche des Katheters angehobenen proximalen Abschnitt aufweist, der eine distale Stirnfläche aufweist, und

ein distales Ende (120), das einen ersten Abschnitt einer für ein Erfassen von Zielgewebe für Reparatur im Herzen angepassten Klemmbackenanordnung aufweist;

eine Reparaturkassette (102), die gleitbar in den Katheter (104; 106) einsetzbar ist, wobei die Reparaturkassette (102) eine Reparaturvorrichtung trägt, die in Verbindung mit dem Entfaltungsmechanismus in das Zielgewebe entfaltet werden kann und eine Welle (126) mit einer Spitze (128) an einem distalen Ende der Welle (126), die einen zweiten Abschnitt der Klemmbackenanordnung bildet, aufweist, wobei das Bilderzeugungselement für ein Bestätigen der einwandfreien Erfassung des Zielgewebes durch die Klemmbackenanordnung konfiguriert ist;

einen länglichen, entfernbar verriegelungsmechanismus (110), der für einen Eingriff mit dem Katheter (104; 106) in Längsrichtung entlang einer Länge einer äußeren Umkreisfläche des Katheters (104; 106) konfiguriert ist und somit durch die Anordnung zwischen der proximalen Stirnfläche des Durchlasses und der distalen Stirnfläche des Katheters (104; 106) eine physische Barriere bereitstellt, um eine distale Bewegung des Katheters (104; 106) relativ dem Durchlass (108) zu verhindern, und der ferner konfiguriert ist, um entfernbar von Kontakt mit sowohl dem Katheter (104; 106) als auch dem Durchlass (108) zu sein, so dass der Katheter relativ dem Durchlass (108) distal frei gleiten kann; und

eine Dichtung (138; 140), die innerhalb der Öffnung (139) des Durchlasses (108) positioniert ist, wobei die Dichtung (138; 140) angepasst ist,

um ein Austreten von Blut aus dem Herzen durch den Durchlass (108) während der Vorkehrungen für ein selektives Einbringen und Entfernen von Katheter (104; 106) und Reparaturkassette (102) durch den Durchlass (108) bei schlagendem Herzen des Patienten im Wesentlichen zu verhindern.

5

10

15

20

25

30

35

40

45

50

55

2. System nach Anspruch 1, wobei der Katheter (104; 106) einen bildgebenden Katheter (106) umfasst, der das Bilderzeugungselement trägt, und einen separaten Entfaltungskatheter (104), der den Entfaltungsmechanismus trägt.

3. System nach Anspruch 2, wobei der Entfaltungskatheter (104) gleitbar in ein Lumen des bildgebenden Katheters (106) eingebracht werden kann.

4. System nach Anspruch 2, wobei der Entfaltungskatheter (104) und der bildgebende Katheter (106) selektiv in ein gemeinsames Lumen in den Katheter (104; 106) eingesetzt werden können.

5. System nach Anspruch 2, ferner aufweisend eine zweite Reparaturkassette, die mindestens teilweise eine zweite Reparaturvorrichtung trägt, wobei die zweite Reparaturkassette für Ersetzen der Reparaturkassette (102) im System nach dem Entfalten der Reparaturvorrichtung angepasst ist.

6. System nach Anspruch 5, ferner aufweisend einen zweiten Entfaltungskatheter, wobei die zweite Reparaturkassette in den zweiten Entfaltungskatheter eingesetzt werden kann.

7. System nach Anspruch 1, wobei die Reparaturvorrichtung eine Naht ist.

8. System nach Anspruch 7, ferner aufweisend ein Pledget (162), an dem die Naht nach dem Entfalten der Naht angebracht werden kann, wobei das Pledget (162) angepasst ist, um direkt mit dem Zielgewebe in Verbindung zu stehen.

9. System nach Anspruch 1, wobei die mindestens eine Dichtung (138; 140) mindestens eine erste Dichtung (138) und eine zweite Dichtung (140) aufweist, wobei die erste Dichtung (138) eine Öffnung (142) für Abdichten um eine äußere Oberfläche des Katheters (104; 106) herum angepasst ist und die zweite Dichtung (140) mehrere Schlitze (144) aufweist, die allgemein abgedichtet verbleiben, wenn der Katheter (104; 106) nicht durch die zweite Dichtung (140) eingeführt ist.

10. System nach Anspruch 1, wobei das mindestens eine Bilderzeugungselement mehrere innerhalb mindestens eines dezidierten Lumens (112) des bildge-

benden Katheters (106) getragene Faseroptiken aufweist.

11. System nach Anspruch 1, wobei die Spitze der Reparaturkassette (102) ein sich verjüngendes distales Ende aufweist. 5
12. System nach Anspruch 1, wobei der Durchlass (108) einen stabilisierenden Abschnitt (134) aufweist, der mit der Herzwand in Eingriff kommen und diese abdichten kann, und der sich in das Herz erstreckt, um Zugang zum Inneren des Herzens durch den Durchlass (108) bereitzustellen. 10
13. Verfahren zum Bereitstellen von Systemen und Anweisungen für Reparatur einer Herzklappe, wobei das Verfahren Folgendes umfasst: 15

Bereitstellen eines der Systeme nach den Ansprüchen 1 bis 13; und 20

Bereitstellen von Anweisungen für Betreiben der Systeme nach den Ansprüchen 1 bis 13 für Reparatur der Herzklappe. 25

Revendications

1. Système pour réparer une valvule cardiaque dans un coeur battant d'un patient, comprenant : 30

un orifice (108) adapté pour couvrir une paroi du coeur du patient, l'orifice (108) ayant une ouverture (139) s'étendant à travers ce dernier, configurée pour fournir l'accès à l'intérieur du coeur, et une surface orientée de manière proximale ; 35

un cathéter (104 ; 106) pouvant être inséré, de manière coulissante, dans l'ouverture (139) de l'orifice (108), le cathéter (104 ; 106) comprenant au moins un élément d'imagerie et un mécanisme de déploiement et le cathéter ayant en outre une partie proximale qui est relevée par rapport à la surface externe du cathéter, la partie proximale comprenant une surface orientée de manière distale, et 40

une extrémité distale (120) qui forme une première partie d'un ensemble de mâchoires, adapté pour saisir le tissu cible pour la réparation dans le coeur ; 45

une cartouche de réparation (102) pouvant être insérée, de manière coulissante, dans le cathéter (104 ; 106), la cartouche de réparation (102) portant un dispositif de réparation qui peut être déployé dans le tissu cible conjointement avec le mécanisme de déploiement et ayant un arbre (126) avec une pointe (128) au niveau d'une extrémité distale de l'arbre (126) qui forme une seconde partie de l'ensemble de mâchoires, dans 50 55

lequel l'élément d'imagerie est configuré pour confirmer la capture correcte du tissu cible avec l'ensemble de mâchoires ;

un mécanisme de verrouillage amovible allongé (110) configuré pour se mettre en prise avec le cathéter (104 ; 106) de manière longitudinale le long d'une longueur d'une surface circonférentielle externe du cathéter (104 ; 106), et fournir ainsi une barrière physique prise en sandwich entre la surface orientée de manière proximale de l'orifice et la surface orientée de manière distale du cathéter (104 ; 106) pour empêcher le cathéter (104 ; 106) de se déplacer de manière distale par rapport à l'orifice (108), et en outre configuré pour pouvoir être retiré du contact à la fois du cathéter (104 ; 106) et de l'orifice (108), de sorte que le cathéter est libre de coulisser de manière distale par rapport à l'orifice (108) ; et un joint d'étanchéité (138 ; 140) positionné à l'intérieur de l'ouverture (139) de l'orifice (108), le joint d'étanchéité (138 ; 140) étant adapté pour empêcher le sang de s'échapper du coeur par l'orifice (108) tout en fournissant l'insertion et le retrait sélectifs du cathéter (104 ; 106) et de la cartouche de réparation (102) par l'orifice (108) alors que le coeur du patient bat.

2. Système selon la revendication 1, dans lequel le cathéter (104 ; 106) comprend un cathéter d'imagerie (106) portant l'élément d'imagerie et un cathéter de déploiement (104) séparé portant le mécanisme de déploiement. 30
3. Système selon la revendication 2, dans lequel le cathéter de déploiement (104) peut être inséré, de manière coulissante, dans une lumière du cathéter d'imagerie (106). 35
4. Système selon la revendication 2, dans lequel le cathéter de déploiement (104) et le cathéter d'imagerie (106) peuvent être insérés de manière sélective dans une lumière commune dans le cathéter (104 ; 106). 40
5. Système selon la revendication 2, comprenant en outre une seconde cartouche de réparation portant au moins partiellement un second dispositif de réparation, la seconde cartouche de réparation étant adaptée pour remplacer la cartouche de réparation (102) dans le système suite au déploiement du dispositif de réparation. 45 50
6. Système selon la revendication 5, comprenant en outre un second cathéter de déploiement, dans lequel la seconde cartouche de réparation peut être insérée dans le second cathéter de déploiement. 55
7. Système selon la revendication 1, dans lequel le dis-

positif de réparation est une suture.

8. Système selon la revendication 7, comprenant en outre une compresse (162) sur laquelle la suture peut être fixée suite au déploiement de la suture, la compresse (162) étant adaptée pour s'interfacer directement avec le tissu cible. 5
9. Système selon la revendication 1, dans lequel le au moins un joint d'étanchéité (138 ; 140) comprend au moins un premier joint d'étanchéité (138) et un second joint d'étanchéité (140), le premier joint d'étanchéité (138) ayant une ouverture (142) adaptée pour se sceller autour d'une surface externe du cathéter (104 ; 106) et le second joint d'étanchéité (140) ayant une pluralité de fentes (144) qui restent généralement scellées lorsque le cathéter (104 ; 106) n'est pas inséré à travers le second joint d'étanchéité (140). 10
15
20
10. Système selon la revendication 1, dans lequel le au moins un élément d'imagerie comprend une pluralité de fibres optiques portées à l'intérieur d'au moins une lumière (112) dédiée dans le cathéter d'imagerie (106). 25
11. Système selon la revendication 1, dans lequel la pointe de la cartouche de réparation (102) a une extrémité distale progressivement rétrécie. 30
12. Système selon la revendication 1, dans lequel l'orifice (108) comprend une partie de stabilisation (134) qui peut se mettre en prise avec et sceller la paroi cardiaque et s'étendre dans le coeur pour fournir l'accès à l'intérieur du coeur par l'orifice (108). 35
13. Procédé pour fournir des systèmes et des instructions pour réparer une valvule, comprenant les étapes suivantes : 40
- prévoir l'un quelconque des systèmes selon les revendications 1 à 13 ; et
- fournir des instructions pour actionner les systèmes selon les revendications 1 à 13 afin de réparer la valvule. 45

50

55

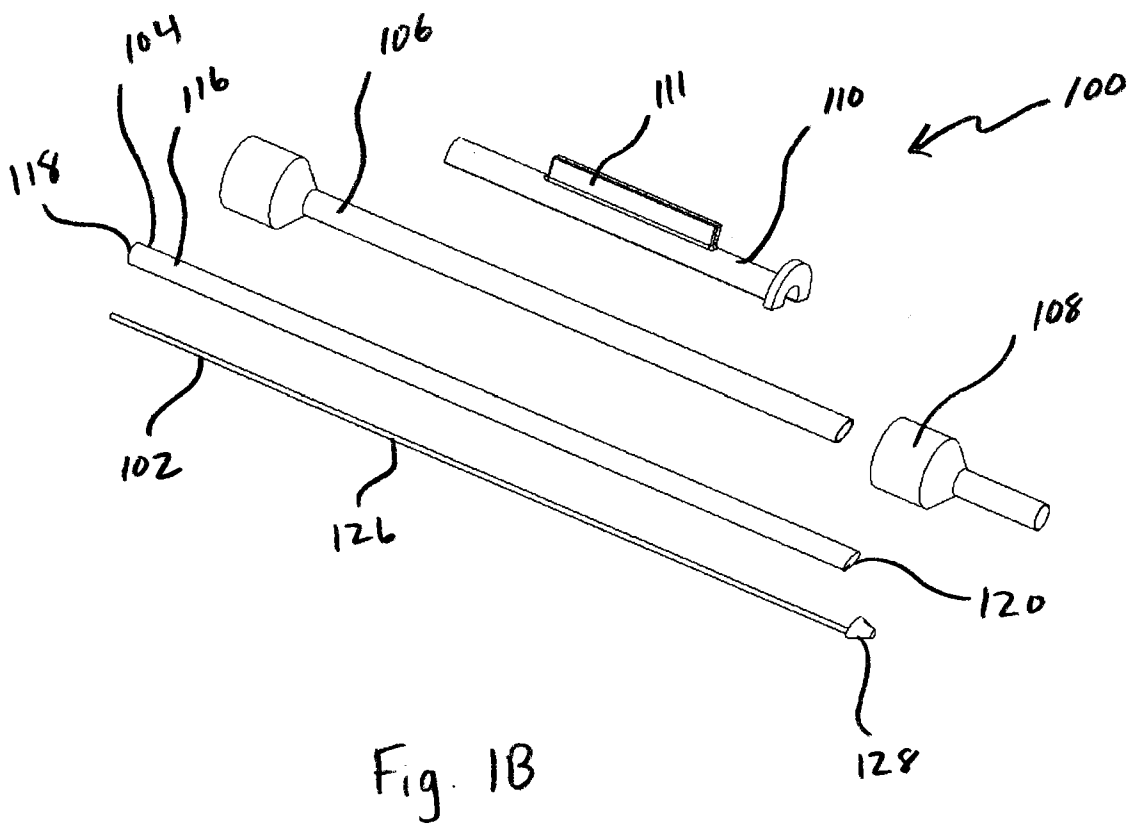
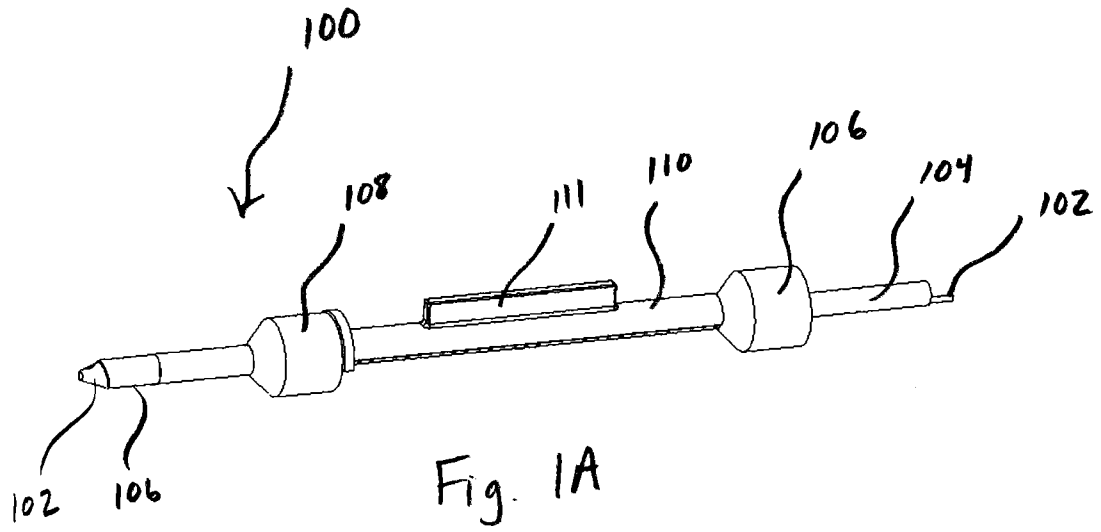

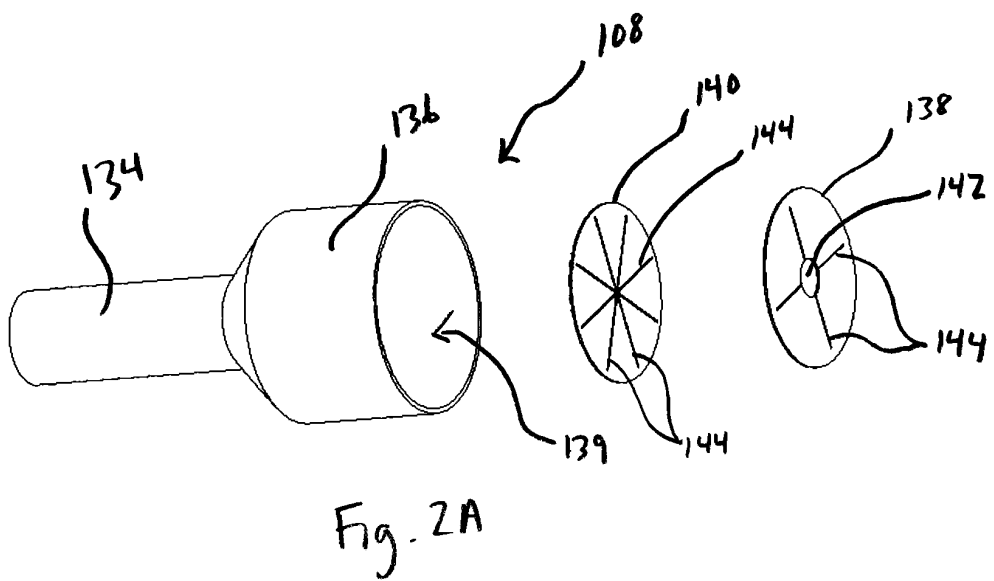
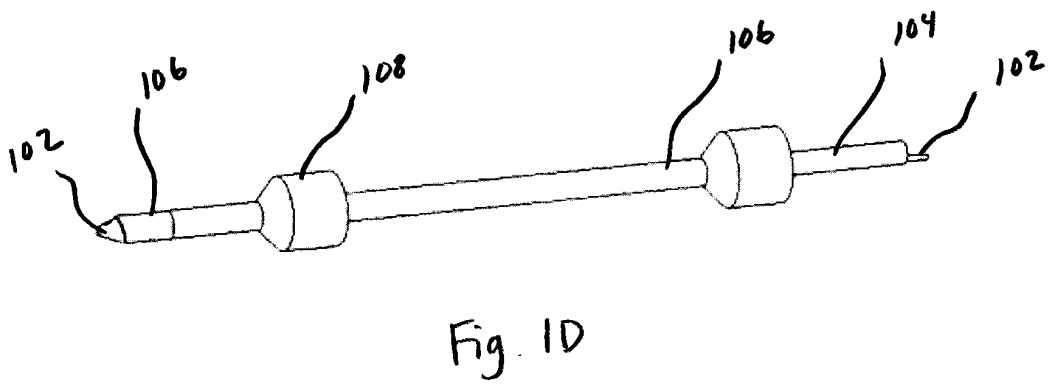
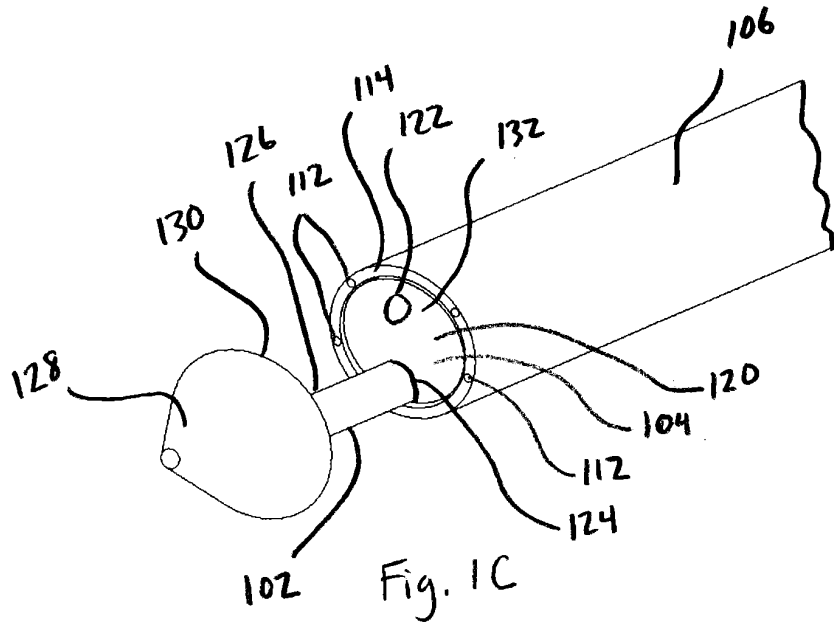

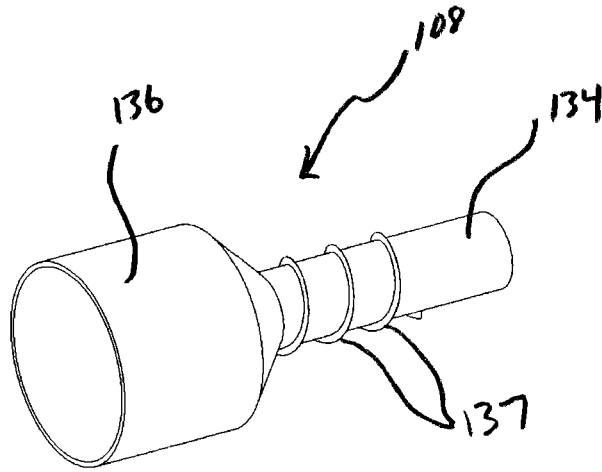

Fig. 2B

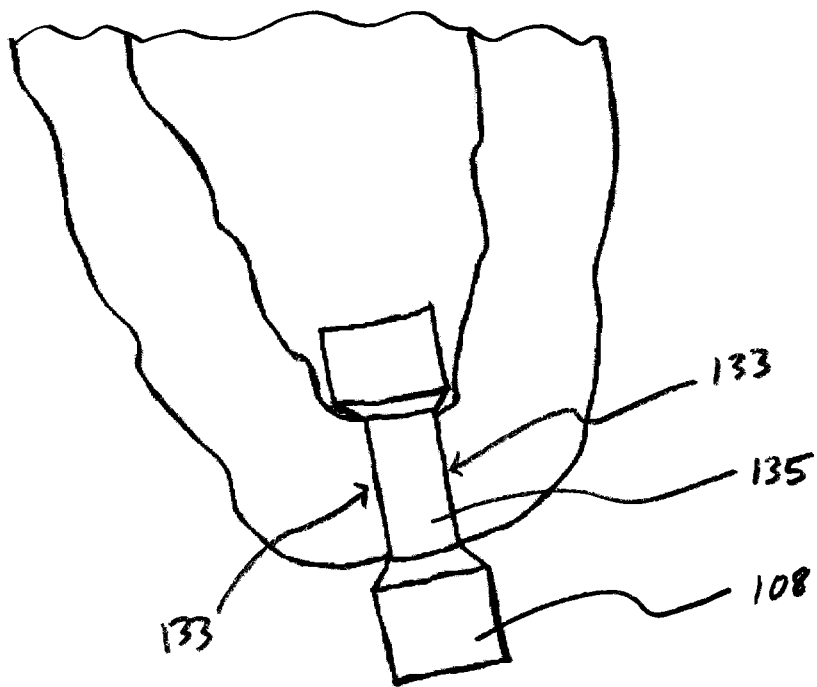
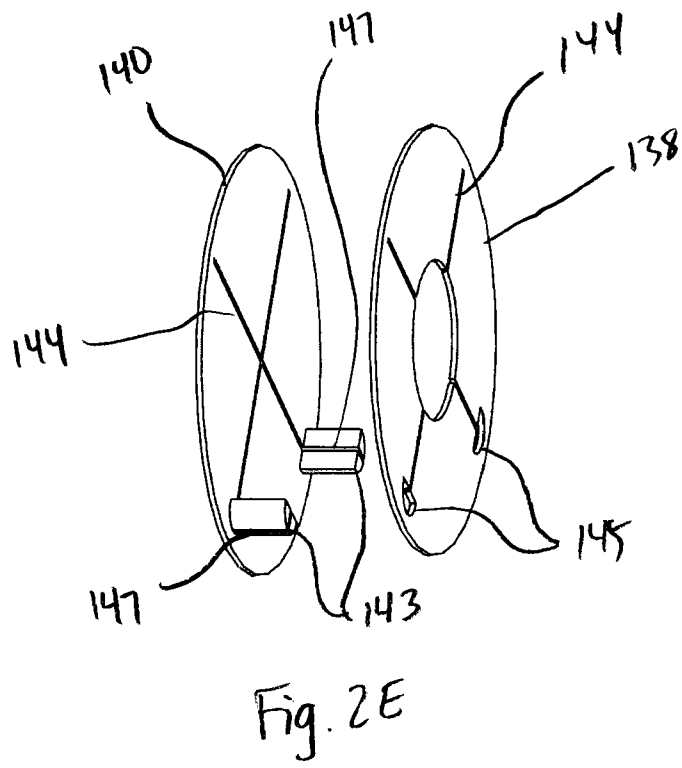
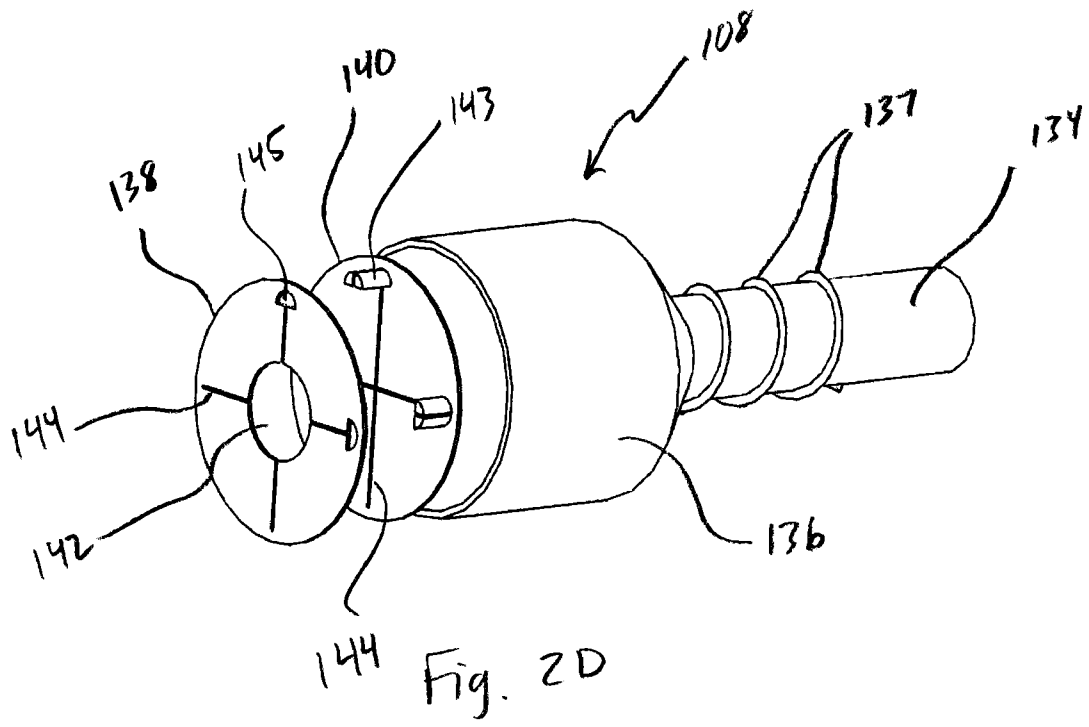

Fig. 2C



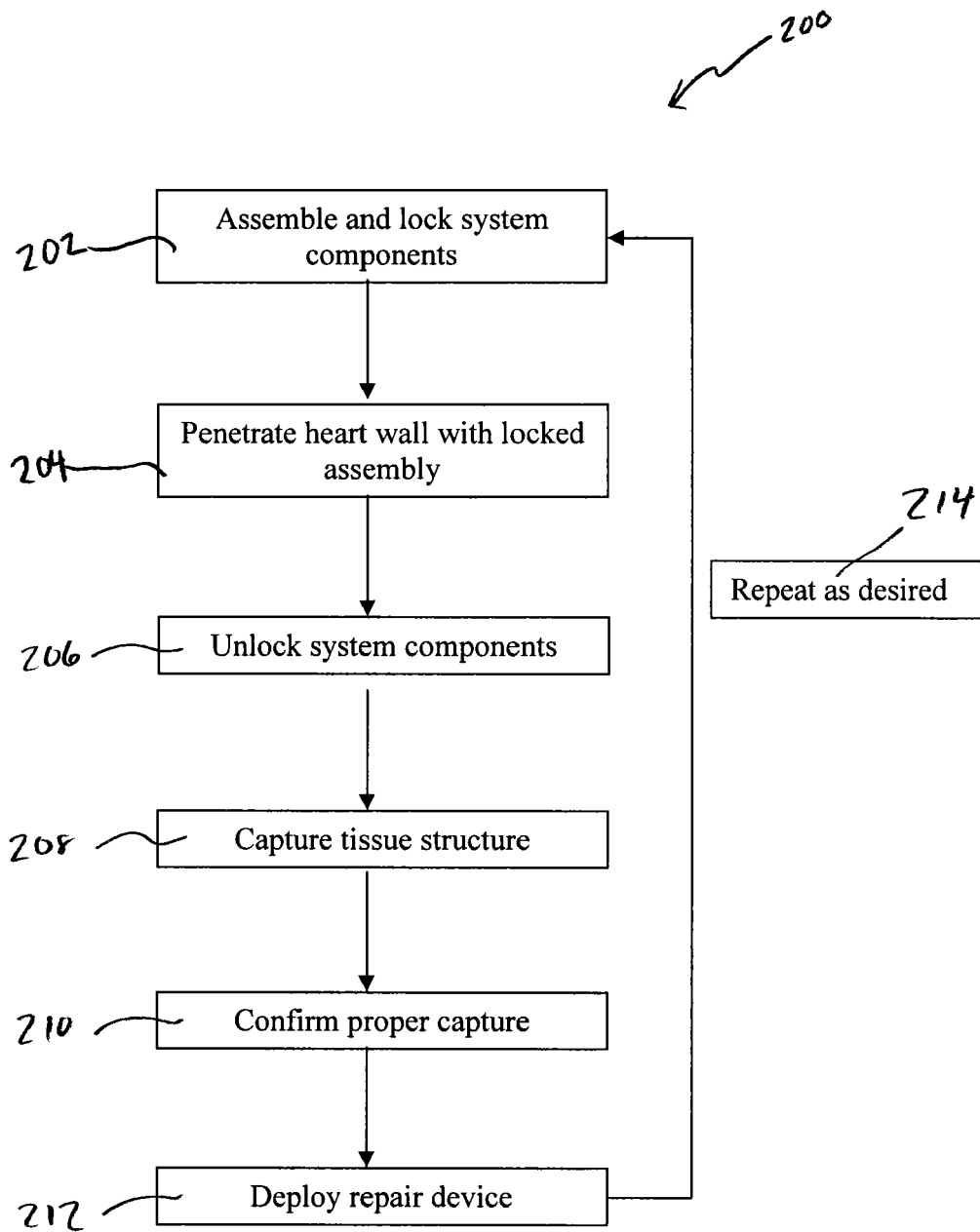

Fig. 3

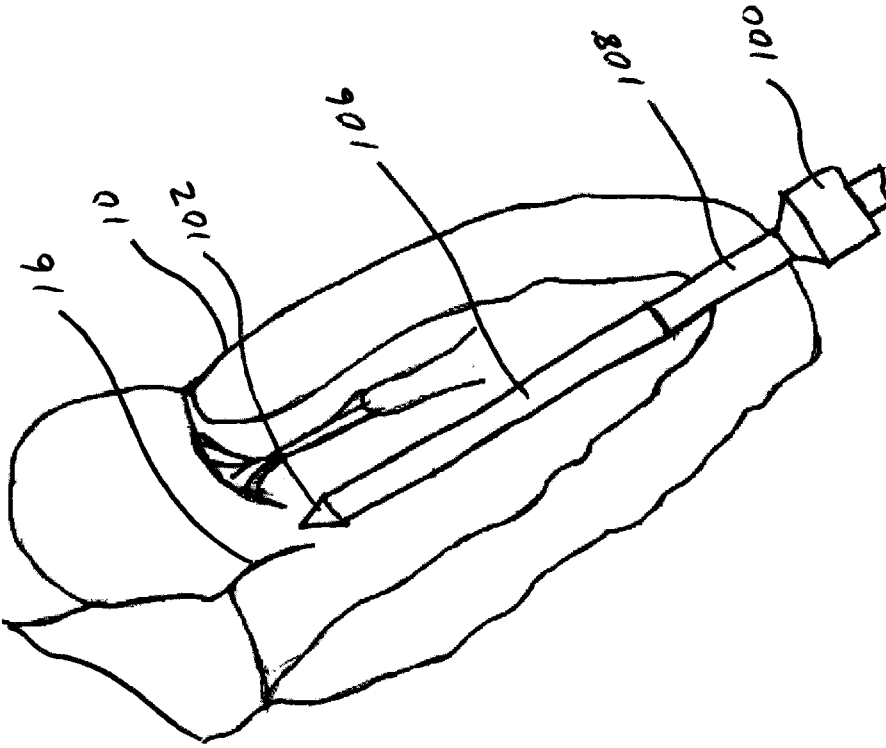

Fig. 4B

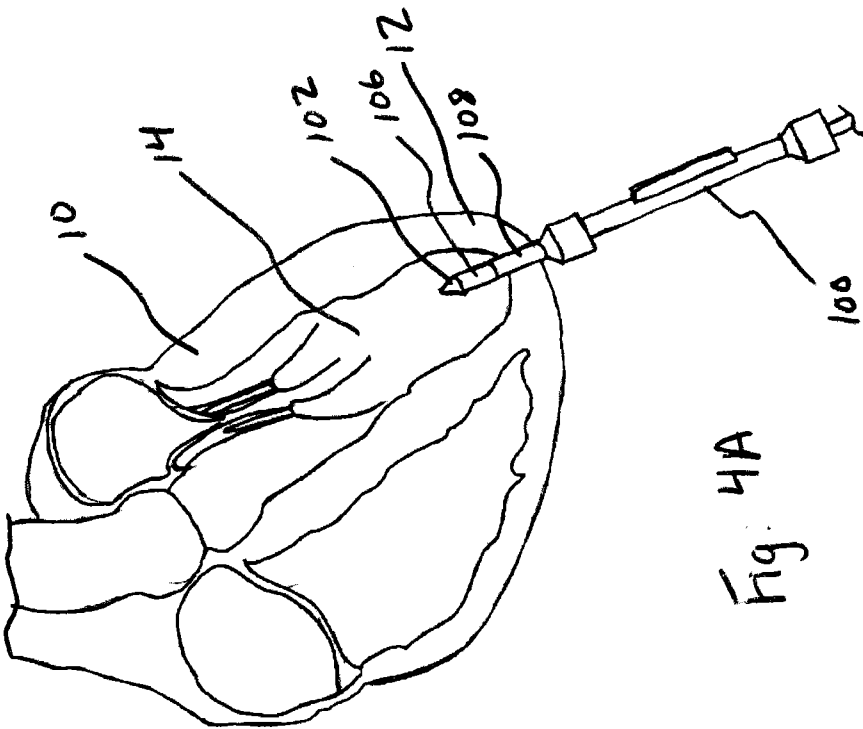

Fig. 4A

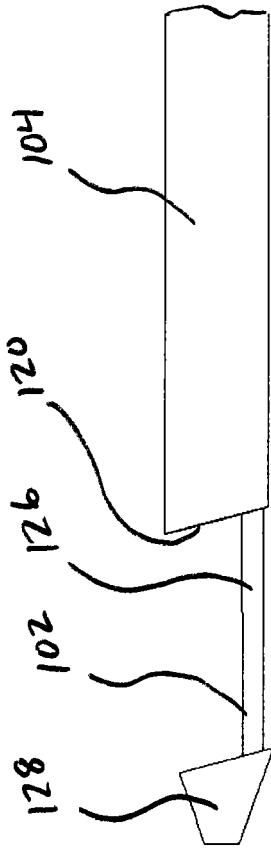

Fig. 5

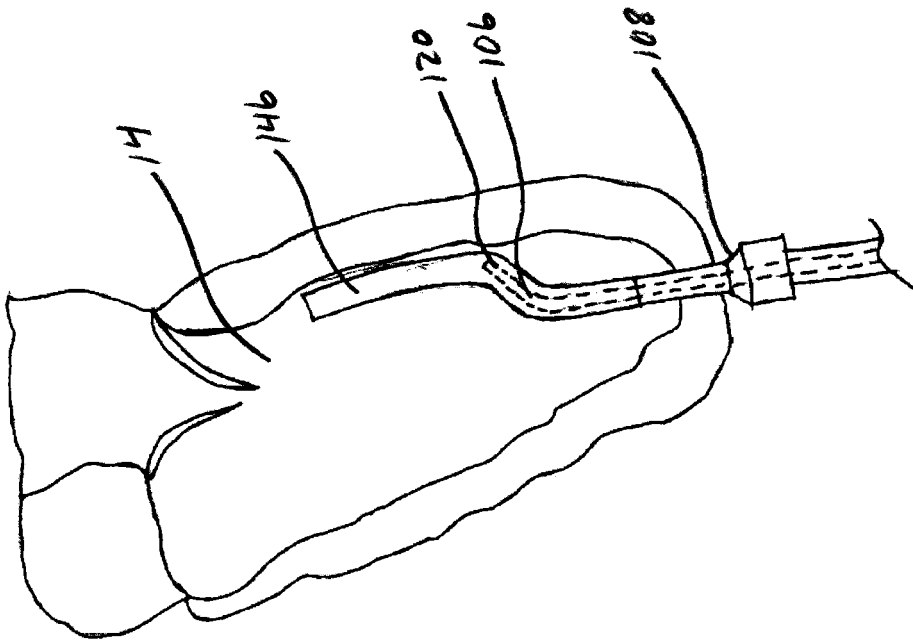

Fig. 7

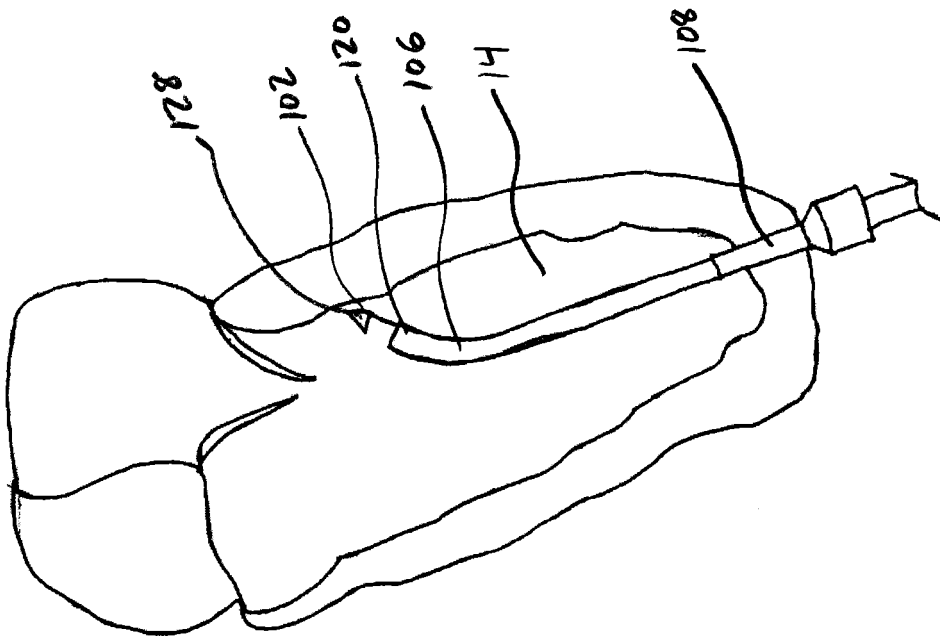

Fig. 6

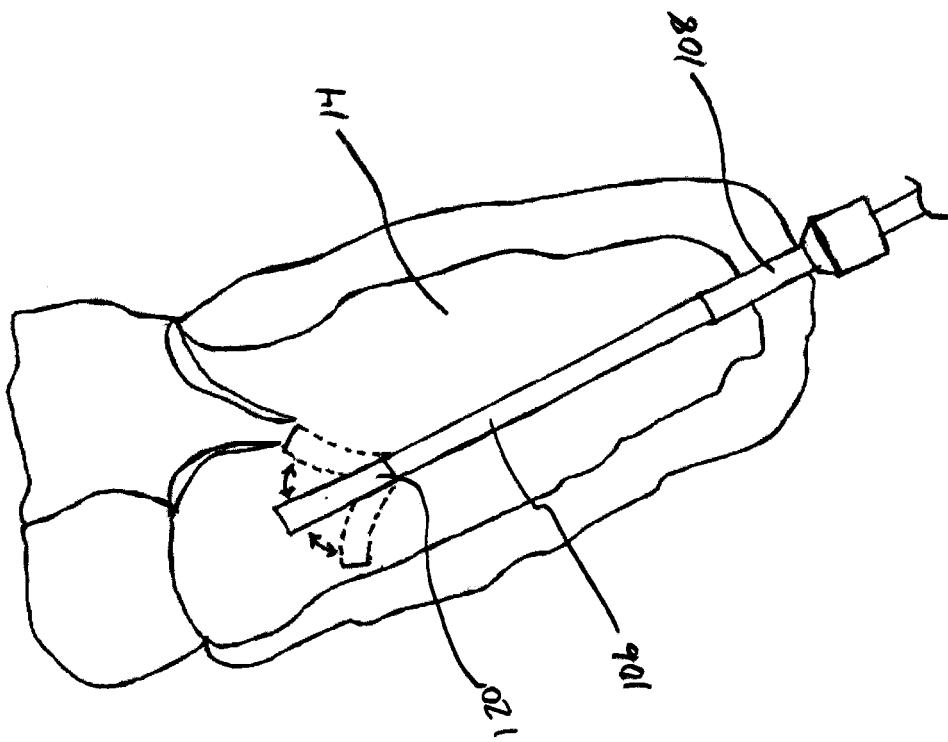

Fig. 8

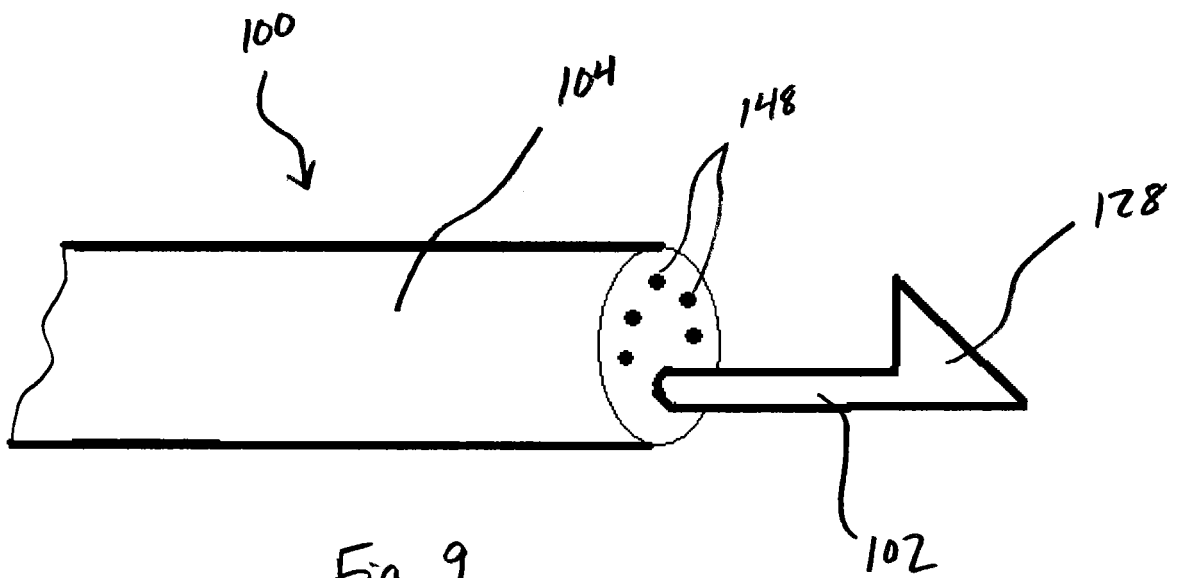

Fig. 9

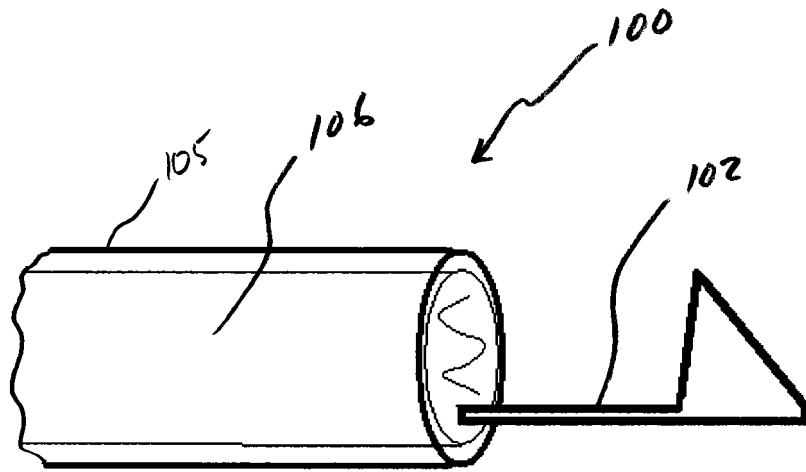

Fig 10A

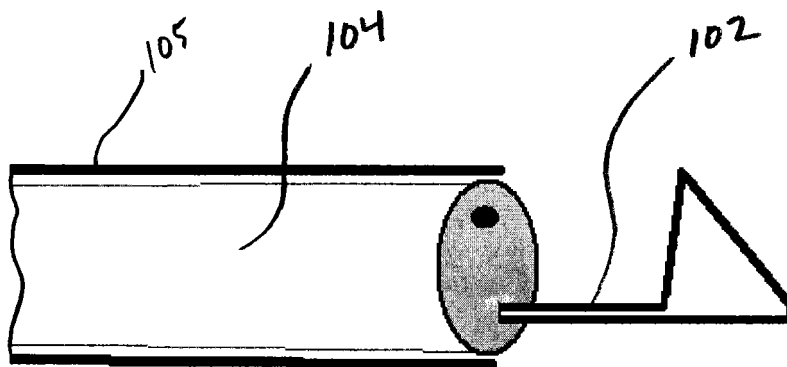
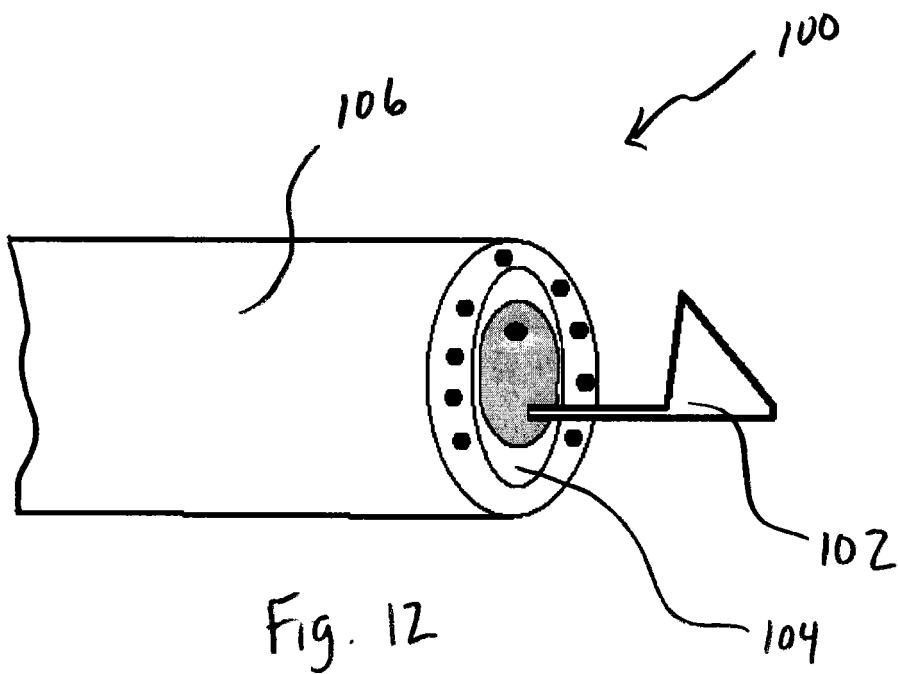
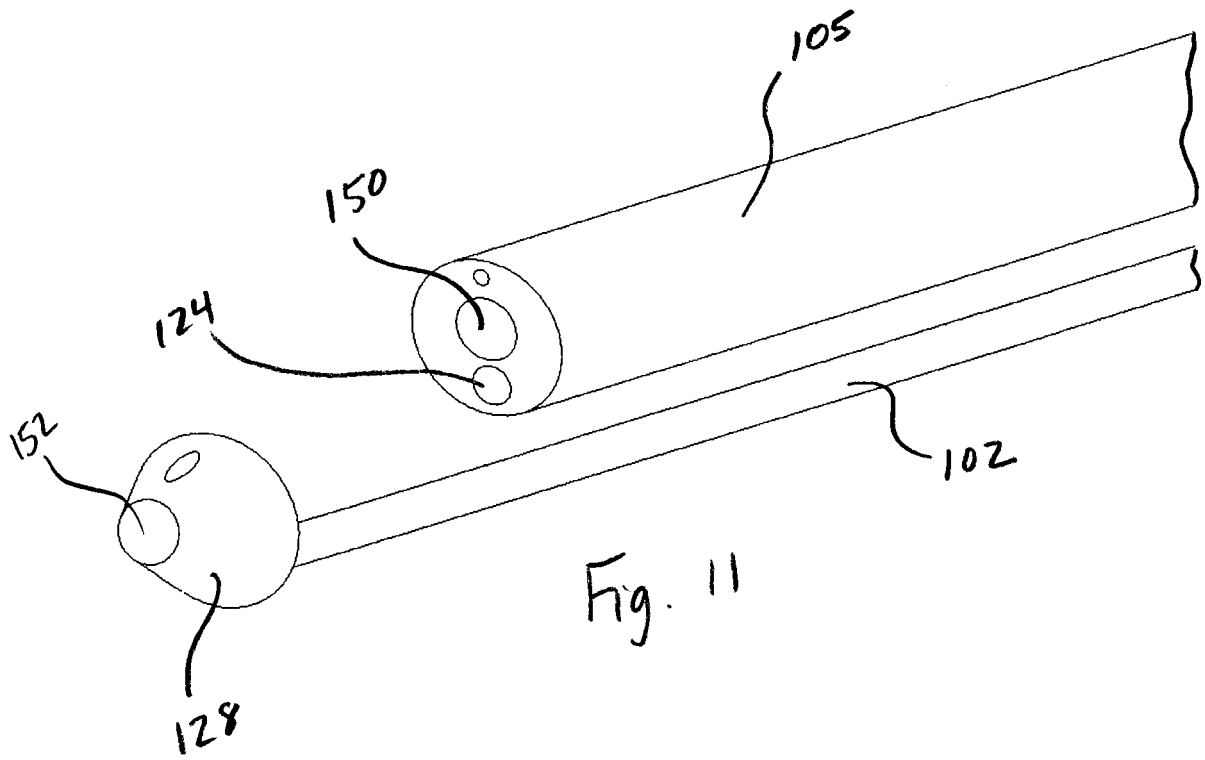

Fig. 10B



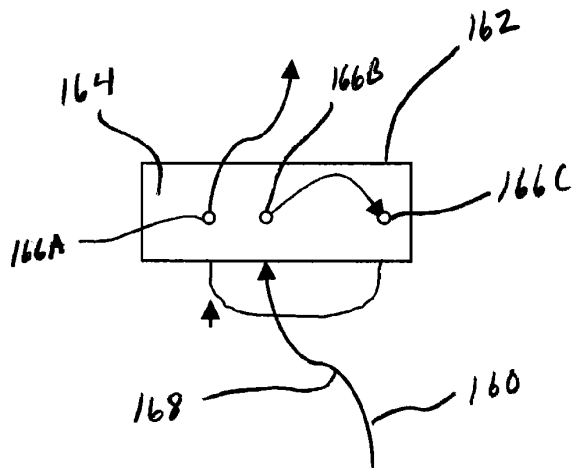

Fig. 13A

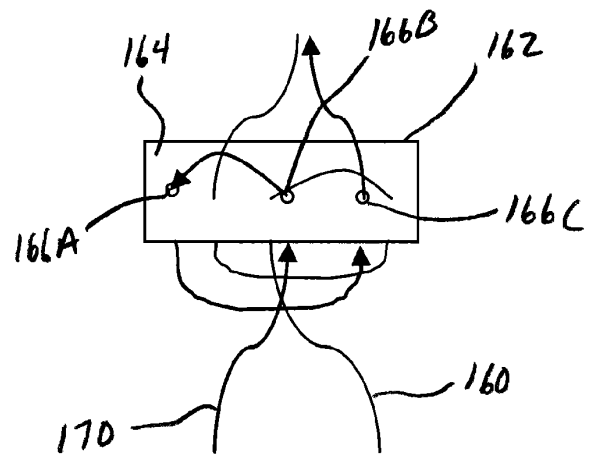

Fig. 13B

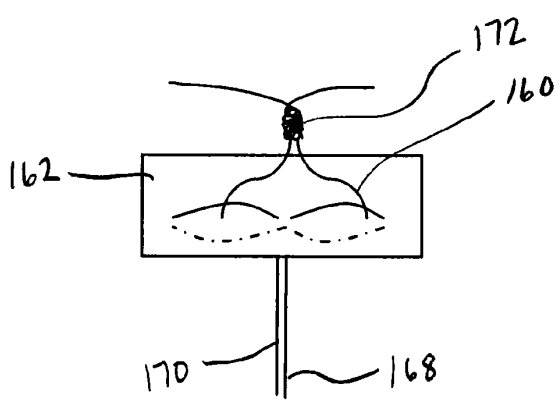

Fig. 13C

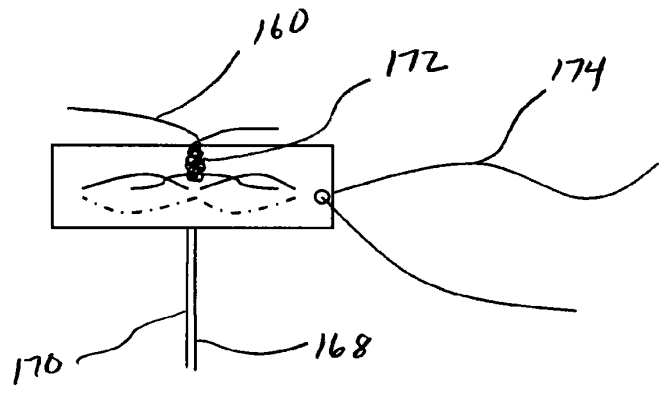
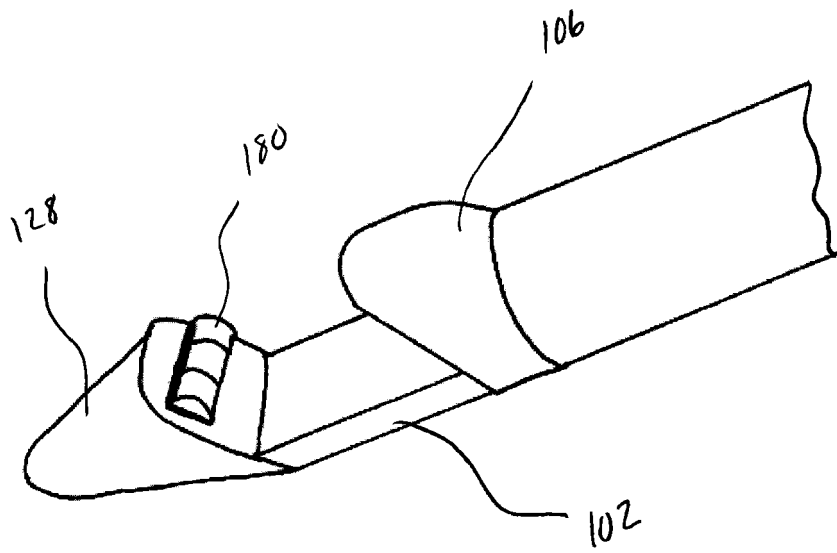
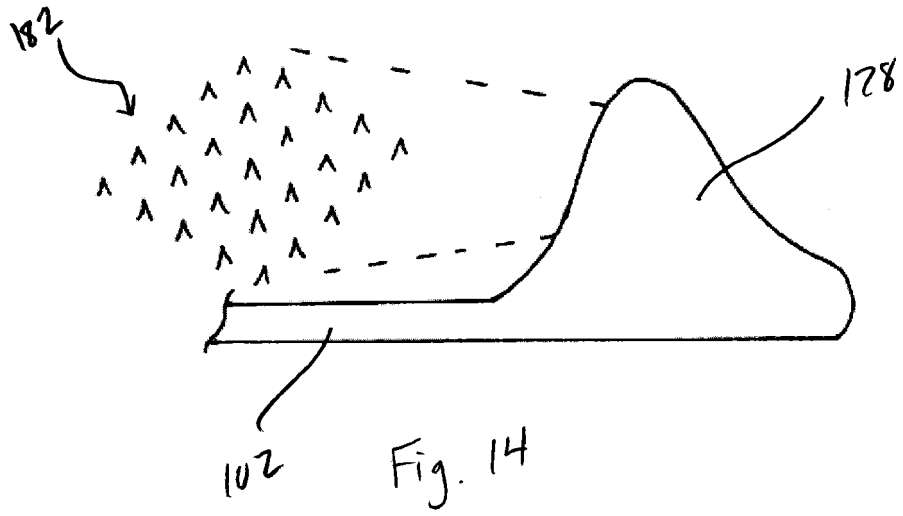

Fig. 13D



REFERENCES CITED IN THE DESCRIPTION

This list of references cited by the applicant is for the reader's convenience only. It does not form part of the European patent document. Even though great care has been taken in compiling the references, errors or omissions cannot be excluded and the EPO disclaims all liability in this regard.

Patent documents cited in the description

- WO 2006078694 A2, Speziali **[0013]** **[0026]**
- US 20080228223 A, Alkhatib **[0013]**
- US 20090105751 A **[0014]** **[0026]**
- US 20090105729 A, Zentgraf **[0014]** **[0026]**
- US 7635386 B, Gammie **[0015]**

专利名称(译)	用于心脏瓣膜小叶微创心脏修复的可交换系统		
公开(公告)号	EP2658480A4	公开(公告)日	2015-12-30
申请号	EP2011863521	申请日	2011-12-29
[标]申请(专利权)人(译)	尼奥绰德有限公司		
申请(专利权)人(译)	NEOCHORD INC.		
当前申请(专利权)人(译)	NEOCHORD INC.		
[标]发明人	ZENTGRAF JOHN PARINS DAVID JOSEPH SAINI ARUN		
发明人	ZENTGRAF, JOHN PARINS, DAVID, JOSEPH SAINI, ARUN		
IPC分类号	A61F2/24 A61M25/01 A61F2/76 A61B1/00 A61B1/018 A61B1/04 A61B1/313 A61B5/00 A61B17/00 A61B17/04 A61B17/06 A61B17/08 A61B17/34 A61B90/00 A61M37/00 A61M39/06		
CPC分类号	A61F2/2466 A61B1/00165 A61B1/018 A61B1/04 A61B1/3137 A61B5/0044 A61B5/0084 A61B17/0401 A61B17/0469 A61B17/0483 A61B17/06114 A61B17/08 A61B17/3462 A61B2017/00057 A61B2017 /00199 A61B2017/00278 A61B2017/00296 A61B2017/003 A61B2017/00349 A61B2017/0042 A61B2017/00477 A61B2017/00783 A61B2017/00876 A61B2017/0406 A61B2017/0409 A61B2017 /0417 A61B2017/0464 A61B2017/3419 A61B2017/3425 A61B2017/349 A61B2090/034 A61F2/2412 A61F2/2442 A61F2/2445 A61F2/2457 A61M37/0015 A61M2039/064 A61M2039/0653		
优先权	61/428048 2010-12-29 US		
其他公开文献	EP2658480B1 EP2658480A1		
外部链接	Espacenet		

摘要(译)

用于心脏瓣膜修复的方法和装置利用心脏瓣膜修复装置，其包括大致环形的环状结构和网状结构。环状结构位于瓣膜环中，网状结构从环状结构延伸穿过瓣叶之间的接合区。然后可以用缝合线将网状结构锚定到心脏结构。小叶之间延伸的网状结构有助于防止小叶脱垂，并有助于接合。