

(19)



(11)

EP 2 599 435 B1

(12)

EUROPEAN PATENT SPECIFICATION

(45) Date of publication and mention of the grant of the patent:
27.09.2017 Bulletin 2017/39

(51) Int Cl.:
H01Q 1/00 ^(2006.01) **H01Q 1/44** ^(2006.01)
H04W 4/00 ^(2009.01) **A61B 5/00** ^(2006.01)

(21) Application number: **12194875.6**

(22) Date of filing: **29.11.2012**

(54) Hospital bed having near field communication capability

Krankenhausbett mit Nahfeldkommunikationsfähigkeit

Lit d'hôpital à capacité de communication en champ proche

(84) Designated Contracting States:
AL AT BE BG CH CY CZ DE DK EE ES FI FR GB GR HR HU IE IS IT LI LT LU LV MC MK MT NL NO PL PT RO RS SE SI SK SM TR

(30) Priority: **29.11.2011 US 201161564466 P**

(43) Date of publication of application:
05.06.2013 Bulletin 2013/23

(73) Proprietor: **Hill-Rom Services, Inc.**
Batesville, IN 47006-9167 (US)

(72) Inventors:
 • **Dixon, Steven Alan**
Cincinnati, OH Ohio 45247 (US)
 • **Huster, Keith, A**
Sunman, IN Indiana 47041 (US)

- **Vanderpohl, Irvin, John III**
Greensburg, IN Indiana 47240 (US)
- **Schuman, Richard, Joseph**
Cary, NC North Carolina 27511 (US)
- **Lack, Christopher, K**
Milan, IN Indiana 47031 (US)
- **Heil, Thomas, F**
Batesville, IN Indiana 47006 (US)

(74) Representative: **Findlay, Alice Rosemary**
Reddie & Grose LLP
The White Chapel Building
10 Whitechapel High Street
London E1 8QS (GB)

(56) References cited:
WO-A2-2005/022692 JP-A- 2010 153 367
US-A- 5 398 149 US-A1- 2010 007 498

EP 2 599 435 B1

Note: Within nine months of the publication of the mention of the grant of the European patent in the European Patent Bulletin, any person may give notice to the European Patent Office of opposition to that patent, in accordance with the Implementing Regulations. Notice of opposition shall not be deemed to have been filed until the opposition fee has been paid. (Art. 99(1) European Patent Convention).

Description

[0001] The present disclosure relates to connectors having wired and wireless couplings. The present disclosure also relates to apparatus for associating a hospital bed to a location in a healthcare facility or for transferring data between a hospital bed and a network of computer devices in a healthcare facility, but has use in other applications and in other environments as well.

[0002] Wireless communication between patient-support devices, such as hospital beds, and a network of a healthcare facility are known. For example, U.S. Patent No. 7,399,205 discloses the use of wireless communication circuitry in a plug body of a standard AC power plug and a module that is mounted in a room adjacent a standard AC power receptacle or outlet. Having circuitry included in the plug body increases the weight of the plug body and introduces plug retention issues. That is, the added weight of the circuitry in the plug body has a tendency to cause the plug to fall out of the receptacle. Also, in those embodiments of the '205 patent relying on the use of photodiodes for data transfer, the necessary alignment tolerance requirements present issues of their own. Accordingly, there is a need to improve upon the devices of the '205 patent.

[0003] Further prior art is found in US5398149 and JP2010153367.

[0004] The present invention provides an apparatus according to claim, 1.

[0005] The power outlet may comprise, for example, a standard AC power outlet. A DC power outlet is contemplated as an alternative.

[0006] In some embodiments, the first near field communication antenna and the second near field communication antenna may be spaced apart by about four centimeters (4 cm) or less when the first near field communication antenna and the second near field communication antenna communicate wirelessly. It is possible, however, for the first and second near field communication antennae to be spaced apart by a greater distance, such as up to 3 inches (7.62 cm) apart, as long as the first and second near field communication antennae are able to successfully receive wireless signals from each other. According to this disclosure, the first near field communication antenna may optionally be included in a label that may stick to the plug body.

[0007] In some embodiments, the first near field communication antenna may serve as a passive target and the second near field communication antenna may be coupled to initiator circuitry that may actively generate a radio frequency field via the second near field communication antenna to power up the passive target for data transfer. Alternatively or additionally, the second near field communication antenna may serve as a passive target and the first near field communication antenna may be coupled to initiator circuitry that actively generates a radio frequency field via the first near field communication antenna to power up the passive target for data transfer.

[0008] According to this disclosure, second circuitry may be coupled to the second near field communication antenna. The first and second circuitry may communicate via the first near field communication antenna and the second near field communication antenna according to a peer-to-peer protocol. In some embodiments, a read/write module may be carried by the plug body and coupled to the first near field communication antenna. Alternatively or additionally, a read/write module may be coupled to the second near field communication antenna.

[0009] In some embodiments, the communication module may include a housing that may be in close proximity to the power outlet. The second near field communication antenna may be situated in the housing. Optionally, the housing may have an opening through which the plug may be inserted to couple to the power outlet. According to this disclosure, the communication module may comprise a mounting plate that may mount over a cover plate associated with the power outlet. The housing may, in turn, couple to the mounting plate. In some embodiments, the communication module may comprise a Nurse Call cancel button.

[0010] The invention will now be further described by way of example with reference to the accompanying drawings, in which:

Fig. 1 is a block diagram showing a power cord and plug of a bed having a first near field communication antenna carried by a plug body of the plug, the bed having first near field communication circuitry coupled thereto, and showing a second near field communication antenna and associated second near field communication circuitry included in a module adjacent a wall outlet;

Fig. 2 is a block diagram, similar to Fig. 1, but having both the first near field communication circuitry and first near field communication antenna carried by the plug body; and

Fig. 3 is a block diagram, similar to Fig. 1, but having an auxiliary power outlet mounted to the bed and additional near field communication antennae and circuitry provided on the bed and on a medical device that receives power from the auxiliary power outlet.

[0011] A power plug 10 at the end of a power cord 12 includes a plug body 14 as shown diagrammatically in Fig. 1. Power plug 10 is a standard AC power plug in some embodiments. In other embodiments, plug 10 is a DC power plug. In the illustrative example, cord 12 extends from a patient support apparatus 16, such as a hospital bed, but the teachings

of this disclosure are applicable to all devices that receive power via an AC power plug and that transmit or receive data. Such devices may include computers of all types, home appliances, industrial equipment, laboratory equipment, data acquisition equipment, monitoring equipment, musical equipment, telecommunications devices, audio equipment, and video equipment, just to name a few. Plug 10 includes prongs 18 that are received in sockets 22 of a standard AC power outlet or receptacle. The words "outlet" and "receptacle" are used interchangeably in this disclosure.

[0012] According to this disclosure, a first near field communication (NFC) antenna 24 is carried by plug body 14 and a second NFC antenna 26 is included in a communication module 28 that is located in proximity to outlet 20. In the illustrative examples of Figs. 1 and 2, module 26 is coupled to a computer network 30 with which bed 16 communicates. Network 30 includes, for example, computer devices such as nurse call computers, electronic medical records (EMR) computers, admission/discharge/transfer (ADT) computers, and the like in those embodiments in which plug 10 and module 26 is used in the healthcare setting with medical devices such as bed 16. Examples of the type of communication equipment included in various embodiments of a nurse call system (as well as network 30, in general) can be found in U.S. Patent Nos. 7,746,218; 7,538,659; 7,319,386; 7,242,308; 6,897,780; 6,362,725; 6,147,592; 5,838,223; 5,699,038 and 5,561,412 and U.S. Patent Application Publication Nos. 2009/0217080; 2009/0214009; 2009/0212956; and 2009/0212925.

[0013] In the illustrative examples of Figs. 1 and 2, first NFC antenna 24 is coupled to first near field communication circuitry 32 and second NFC antenna 26 is coupled to second near field communication circuitry 34. In the Fig. 1 example, circuitry 32 is carried by bed 16, such as by being mounted to a bed frame of bed 16, and is coupled to antenna 24 via one or more conductors 36 routed along cable 12. In some examples, the power conductors of cable 12 (i.e., the conductors that couple to prongs 18) and conductors 36 are contained within the same cable jacket. Optionally, shielding is provided so as to reduce or eliminate the AC power from interfering with the data signals transmitted over conductors 36. In the Fig. 2 embodiment, circuitry 32 is carried by plug body 14' and is coupled to circuitry of bed 16 via one or more conductors 36' that are routed along cable 12.

[0014] Use of NFC antennae 24, 26 and associated circuitry 32, 34 permits simplified transactions, data exchange, and wireless connections between two devices in close proximity to each other, usually by no more than a few centimeters. In the illustrative examples of Figs. 1 and 2, antennae 24, 26 are spaced apart by about 1 inch (2.54 cm). However, suitable results can be achieved with antennae 24, 26 being spaced apart by 4 cm or less. Depending upon the power of circuitry 32, 34 and depending upon the size of antennae 24, 26, a working distance of up to 20 cm may be possible, but in the illustrative examples, communication over such a distance is not needed. Thus, near field communication (NFC) is a short-range wireless communication technology. It is known that NFC operates at a frequency of about 13.56 megahertz (MHz) on ISO/IEC 18000-3 air interface and at data transfer rates from about 106 kilobits per second (kbits/s) to about 424 kbits/s.

[0015] In the illustrative example, circuitry 32 and circuitry 34 are both powered such that bidirectional, peer-to-peer communication is achieved. In other examples, one of antenna 24, 26 and the associated circuitry 32, 34, respectively, serves as an initiator circuit and the other of antenna 24, 26 and associated circuitry 32, 34 serves as a passive target. The initiator actively generates a radio frequency (RF) field that powers the passive target. In such alternative arrangements, the passive targets can be fashioned as tags, stickers, fobs, or cards that do not include batteries or direct connection to external power sources. Thus, according to this disclosure, antenna 24 is included in a label that sticks to plug body 14 (or plug body 14') in some examples. Circuitry 32 and/or circuitry 34 are sometimes referred to as read/write modules according to this disclosure.

[0016] By having NFC antenna 24 included on plug body 14 (or plug body 14') and by having module 28 located in close proximity to outlet 20, the NFC antennae 24, 26 automatically establish communications quickly in roughly one tenth of a second after plug 10 is plugged into outlet 20. Because plug 10 is configured to receive power and is configured to communicate wirelessly with module 26, only one connector (i.e., plug 10) is needed to provide both power and data to device 16 and furthermore, only this single connector needs to be unplugged if device 16 is to be moved to a new location. Due to the short reception range between antennae 24, 26, the likelihood of unwanted interference from other wireless signals is reduced.

[0017] The labels, stickers, or tags that carry the antennae 24, 26 are approximately the size of a U.S. quarter which has a diameter of 24.26 mm (0.955 in) or roughly 1 inch (25.4 mm). Thus, in some examples, the labels carrying antenna 24 are simply stuck onto plug body 14, 14'. The antenna 24, 26 can be placed up to 10 feet (3.048 m) away from a transceiver chip of the associated circuitry 32, 34. Thus, in the Fig. 1 example, conductor 36 has a maximum length of about ten feet (3.048 m). In some examples, circuitry 32, 34 includes TRF7970A transceiver boards available from Texas Instruments of Dallas, Texas. By placing the circuitry 32 on bed 16 as shown in the Fig. 1 example, plug body 14 only has the added weight of antenna 24 and a small portion of the length of conductors 36. Thus, plug 10 has less of a tendency to fall out of socket 20 which is an improvement over the embodiments shown and described in U.S. Patent No. 7,399,205. Circuitry 32 may be included in an electronics housing mounted on a frame of bed 16, for example. In other examples contemplated by this disclosure, however, circuitry 32 is carried by the plug body 14' as shown in Fig. 2.

[0018] The module 28 which carries antenna 26 and associated circuitry 34 can be fashioned in any number of ways,

including the various embodiments shown in U.S. Patent No. 7,399,205. For example, module 28 may be fashioned as a wall plate that carries antenna 26 and that has an opening through which the sockets 22 of AC power outlet 20 are accessible for receiving prongs 18 of plug 10. The wall plate carrying the antenna 26 is configured to cover an existing wall plate associated with the AC power outlet 20 in some examples. Such an example of a wall plate may be fashioned similarly to the embodiment of Figs. 1-4 of U.S. Patent No. 7,399,205, for example.

[0019] In other examples, the wall plate or module carrying antenna 26 replaces the existing wall plate altogether. In further examples, antenna 26 is carried in a housing or plate that mounts to a wall or similar structure in close proximity to outlet 20 but without covering up any of the existing wall plate of the outlet 20. The term "close proximity" is intended to mean close enough that communications between antenna 26 and antenna 24 is possible when plug 10 is coupled to outlet 20. In still other examples, antenna is carried in a housing of an adapter module that plugs into outlet 20. The adapter module may be fashioned similar to any of those shown in Figs. 8-12 of U.S. Patent No. 7,399,205 for example.

[0020] As shown diagrammatically in Figs. 1 and 2, this disclosure contemplates that circuitry 34 is included in the same module 28 as antenna 26 in some examples. In some examples, such as the illustrative examples, further processor circuitry 40 is also included in module 28. In other examples, circuitry 28 and/or circuitry 40 is included in a housing that is separate from the module 28 that carries antenna 26. In such embodiments, a communication cable interconnects the module 28 carrying antenna 26 with the housing or module carrying circuitry 28 and/or circuitry 40.

[0021] In some examples, module 28 is not connected to network 30 but rather simply serves to provide the circuitry of bed 16 with a location identifier (ID) that is transmitted from antenna 26 to antenna 24. The circuitry of bed 16, in turn, transmits a bed identifier (ID) and the location identifier such as by wireless communications with a wireless access point, for example. In such an example, the wireless access point is coupled to the network 30. Remote computers of the network 30 receive the bed ID and the location ID to associate bed 16 with the location in the healthcare facility at which bed 16 is located. In some examples, bed 16 transmits additional data, such as bed status information, patient physiological data, bed diagnostic data, and so forth. In other examples, the bed ID and/or the additional data is transmitted via antenna 24 to antenna 26 and then on to network 30 via circuitry 34 and/or circuitry 40. The location ID of module 28 is also transmitted so that the bed-to-room association can be made by remote computers in those examples as well.

[0022] Examples of the type of bed data that is transmitted from bed 16 via near field communication circuitry 32, 34 and antennae 24, 26 to network 30, for various embodiments of bed 16, is summarized below in Table 1 as follows:

TABLE 1

0x04 Bed Inputs Messages		Description	Bed Type 1	Bed Type 2	Bed Type 3	Bed Type 4	Bed Type 5	Bed Type 6	
5 10 15	Bed Status	Basic							
		Brake Status	Brake set, brake not set	X	X	X	X	X	X
		Surface Prevent Mode	Not activated, activated	X	X			X	X
		Bed Exit or PPM Armed	Armed, not armed	X	X	X	X	X	X
		Bed Low Position	Bed not down, bed down	X	X	X	X	X	X
		Both Headrails Up	Not down, down	X	X	X	X	X	X
		Both Footrails Up	Not down, down	X	X	X	X	X	
20 25 30 35 40 45 50 55	Enhanced Bed Status	PPM							
		PPM Mode - Positioning	Not selected, mode selected	X	X	X	X		
		PPM Mode-Exiting	Not selected, mode selected	X	X	X	X		
		PPM Mode - Patient Out of Bed	Not selected, mode selected	X	X	X	X		
		PPM or Bed Exit Alarming	Alarming, not alarming	X	X	X	X		
		Rails							
		Right Headrail Position	Not down, down		X	X	X		
		Left Headrail Position	Not down, down		X	X	X		
		Right Footrail Position	Not down, down		X	X	X		
		Left Footrail Position	Not down, down		X	X	X		
		Lockouts							
		Head Motor Lockout	Not locked, locked	X	X	X	X		
		Knee Motor Lockout	Not locked, locked	X	X	X	X		
		High-Low Motor Lockout	Not locked, locked	X	X	X	X		
		All Motor Lockout	Not locked, locked	X	X	X	X		
		Wound Surface							
		Surface Turn Assist Left Mode	Not active, active	X	X				
		Surface Turn Assist Right Mode	Not active, active	X	X				
Surface Max Inflate Mode	Not active, active	X	X						
Heel Suspension Mode	Not active, active	X							
Pulmonary Surface									
Rotation Mode	Not active, active	X							
Opti-Rest Mode	Not active, active	X							
Percussion	Not active, active	X							
Vibration	Not active, active	X							
Maintenance Alerts									
Battery Status Modes, 2 bits	0% charged or disconnected	X	X						
	Not fully charged	X	X						

0x04 Bed Inputs Messages		Description	Bed Bed Bed Bed Bed Bed					
			Type	Type	Type	Type	Type	Type
			1	2	3	4	5	6
5		Battery fully charged	X	X				
	AC Power Not Present Mode	AC present, AC not present	X	X				
	Service Required Message	Service required, no service required	X	X	X	X		
10	Head Angle Alarm							
	Head Angle Alarm Armed	Alarm armed, not armed	X	X		X		
15	Head Angle Alarm Alarming	Alarming, not alarming	X	X		X		
	Head Angle Alarm Suspended	Alarm suspended, not suspended	X					
	Other Bed Data							
20	CPR Mode	CPR switch active, CPR switch not active	X	X				
	AC Power Present Mode	AC present, AC not present	X	X				
25	Nurse Call Switch	Switch active, switch not active	X	X	X	X		
	Care Alert Switch	Switch active, switch not active	X	X	X	X		
	Chair Mode	Bed in chair mode, not in chair mode	X					
30	Head Angle	Variable head angle in degrees	X	X		X		
	Patient Weight	Variable patient weight	X	X	X	X		
35	Patient Weight - Date	Date stamp, part 1: YYYYMMDD	X					
	Patient Weight-Time	Time stamp, part 2: DDHHMMSS	X					
	Bed Configuration and ID							
40	Bed Exit Present	System present, not present	X					
	Prevention Mode Present	System present, not present	X	X				
45	Bed Position (down) Switch	System present, not present	X	X	X	X		
	Brake Switch	System present, not present	X	X	X	X		
50	Footrail Switch(es)	Switch(es) present, not present	X	X	X	X		
	Headrail Switch(es)	Switch(es) present, not present	X	X	X	X		
	Nurse Call Switch	Nurse Call switch present, no Nurse Call	X	X	X	X		
55	PPM Module Installed	PPM present, not		X	X	X		

0x04 Bed Inputs Messages		Description	Bed Bed Bed Bed Bed Bed					
			Type 1	Type 2	Type 3	Type 4	Type 5	Type 6
5		present						
	Scale Module Installed	Scale present, not present	X	X	X	X		
	Dynamic Surface Installed	Air present, not present	X	X				
10	Enhanced Bed Status Protocol	Enhanced Bed Status supported, not supported	X	X	X	X		
	Rotation Module Installed	Module present, not present	X					
15	Perc/Vib Module Installed	Module present, not present	X					
	Bed Serial Number	Side Com board serial number	X	X	X	X		
20	Bed ID	Type and revision of bed	X	X	X	X		

[0023] In the example of Table 1, Bed Type 1 is the TOTALCARE® bed, Bed Type 2 is the VERSACARE® bed, Bed Type 3 is the CAREASSIST® ES bed, Bed Type 4 is the ADVANTA™ 2 bed, Bed Type 5 is the ADVANCE bed, and Bed Type 6 is the ADVANTA bed, each of which is, or was, marketed by Hill-Rom Company, Inc. Beds 16 of other types which have other types of bed data are, of course, usable. Based on Table 1, it will be appreciated that bed data includes, for example, data pertaining to one or more of the following: a position of one portion of a bed frame relative to another portion of the bed frame (e.g., Brake Status, Bed Low Position, Rail positions, Head Angle), a mattress function (e.g., Wound Surface and Pulmonary Surface information), a status of a bed exit alarm system of the hospital bed (e.g., the patient position monitoring (PPM) information), and patient physiologic data (e.g., patient weight). It is also contemplated by this disclosure that maintenance and/or service data is among the type of bed data that is transmitted from bed 16 via near field communication circuitry 32, 34 and antennae 24, 26 to network 30, for various examples of bed 16.

[0024] In some contemplated examples, bed 16 has a mattress and/or bed frame with sensors to sense patient physiologic data (e.g., heart rate, temperature, respiration rate, blood oxygenation, blood pressure, etc.) and that such data is also among the bed data communicated from bed 16 to circuitry 32 and antenna 24 and then on to network 30 via antenna 26 and circuitry 34. An example of a mattress with physiologic sensors can be found in U.S. Patent Nos. 7,515,059; 7,330,127 and 6,721,980. Other examples of mattresses and bed frames having physiologic sensors can be found in U.S. Patent Application Publication No. 2010/0101022.

[0025] Referring now to Fig. 3, an embodiment is shown in which bed 16 includes an auxiliary power outlet 50 which has sockets 52 that receive prongs 54 of a plug 56 provided at the end of a power cord 58 extending from a medical device 60. Medical device 60 may comprise any type of medical device used for providing care to a patient or used in monitoring a patient physiological condition, for example. Thus, examples of some medical devices 60 include IV pumps, blood pressure monitors, electrocardiographs (EKG's), electroencephalographs (EEG's), pulse oximeters, ventilators, respiration monitors, and temperature monitors, just to name a few.

[0026] In some embodiments, power is provided to auxiliary outlet 50 from power cord 12. In such embodiments, isolation circuitry is included in bed 16 so as to isolate bed power from the auxiliary power. In other embodiments, a separate power cord 62 extends from bed 16 and has a plug 64 with prongs 66 that are received in sockets of a power outlet. In the illustrative example of Fig. 3, power cord 62 is shown diagrammatically via a dotted line and prongs 66 of plug 64 are shown arranged for coupling to sockets 22' of a duplex power outlet 20'. Thus, in this alternative embodiment, power cord 62 and auxiliary outlet 50 are not electrically coupled in any way to the circuitry of bed 16, but rather bed 16 serves as a carrier for auxiliary outlet 50. Bed 16 may have more than one auxiliary outlet 50. Thus, the discussion below of near field communication capability associated with one auxiliary outlet 50 is equally applicable for each auxiliary outlet of a bed having multiple such outlets.

[0027] According to this disclosure, bed 16 has an additional near field communication antenna 124 and additional near field communication circuitry 132 in close proximity to auxiliary outlet 50 as shown diagrammatically in Fig. 3. Antenna 124 communicates wirelessly with a further near field communication antenna 126 provided on plug 56. In some embodiments, antenna 126 is included as part of a passive circuit carried by a label coupled to plug 56. In such

embodiments, after the passive circuitry has been activated by circuitry 132 of bed 16 via antenna 124, medical device identification (ID) data is transmitted via antenna 126 to antenna 124 to confirm that a proper device has been plugged into the auxiliary outlet 50.

5 **[0028]** If it is determined by circuitry of bed 16 that an inappropriate or wrong device has been plugged into outlet 50, then bed 16 transmits an appropriate alert message to network 30 and, in some embodiments, disconnects power from auxiliary outlet 50 so as to turn off medical device 60. In some embodiments, bed 16 includes a visual indicator of some sort, such as a message on a graphical display screen or an alert light, to indicate locally that an inappropriate device has been connected to auxiliary outlet 50. Thus, according to this disclosure, bed 16 is configurable such that its one or more auxiliary outlets 50 are designated for specific pieces or equipment or specific types of equipment. The near field communication capability of bed 16 associated with the auxiliary outlet(s) 50 are used to verify that the designated equipment is coupled to outlet(s) 50. In some embodiments, bed 16 interacts with and/or controls device 60 via data transmitted via antennae 124, 126. For example, a touch screen display on bed 16 is configured to accept user inputs for controlling device 60 in some embodiments.

10 **[0029]** In many hospitals and other types of healthcare facilities, there are two separate power grids, one being a critical power grid and the other being a non-critical power grid. Outlets associated with the critical power grid are typically indicated by being red or orange in color and outlets associated with non-critical power grid are typically white or off white in color. During a power outage or other emergency in which power to a hospital or healthcare facility is lost, one or more generators are usually operated to provide back-up power to the critical power grid. It is desirable, therefore, that only critical devices, such as ventilators, infusion pumps, and other devices that provide critical care (e.g., life sustaining care) to a patient are connected to outlets associated with the critical power grid so that noncritical devices do not need to be powered by the back-up generators during an emergency or power outage. Thus, according to this disclosure, near field communication components 124, 126, 132, 134 are used to make sure that only medical devices 60 that are deemed critical (i.e., the appropriate or proper medical devices) are used with the one or more auxiliary outlets 50 of bed 16.

15 **[0030]** In some embodiments, medical devices 60 include near field communication circuitry 134 which is coupled to antenna 126 via conductors 136 as indicated diagrammatically. Circuitry 134 is used for transmitting medical device data to the circuitry of bed 16 via antennae 126, 124 and circuitry 132. Alternatively or additionally, bed data is transmitted to medical device 60 via circuitry 132, 134 and antennae 124, 126. For example, if device 60 is an infusion pump or drug delivery pump, then bed 16 may transmit patient weight data to device 60 which, in turn, may use the patient weight data to establish a rate at which a fluid or drug is administered to the associated patient. As another example, if device 60 senses that its fluid level is running low, then that information may be communicated to bed 16 which, in turn, transmits an alert message to a remote computer device of network 30, including transmission to a portable wireless communication device carried by a caregiver. Alternatively or additionally, a local alert regarding the alert condition of device 60 is displayed locally on bed 16, such as being displayed on a display screen. Circuitry 134 is shown as being carried by medical device 60 in Fig. 3, however, in other embodiments, circuitry 134 is carried by plug 56.

20 **[0031]** In the illustrative embodiment of Fig. 3, data communicated to bed 16 from device 60 via near field communication components 124, 126, 132, 134 is subsequently transmitted to network via near field communication components 24, 26, 32, 34. In other embodiments, near field communication components 24, 26, 32, 34 are omitted and bed transmits data received from device 60 to network 30 via some other wireless communication scheme, such as Wi-Fi communication to a wireless access point, for example, or via a wired connection to network 30. Thus, bed 16 in each of the Fig. 1-3 examples is shown as having optional Wi-Fi circuitry 80 and module 28 is shown as having Wi-Fi circuitry 82. Further features of Wi-Fi circuitry 80, 82 are discussed below.

25 **[0032]** According to one feature, the near field communication components 24, 26, 32, 34 may serve as a secondary or back-up communication channel between bed 16 and remote computer devices of network 30. Thus, bed 16 may couple to network 30 via a separate nurse call cable, such as a 37-pin cable typically used to connect Hill-Rom beds to a nurse call system, which serves as the primary communication channel for data to and from bed 16. In such examples, the primary nurse call channel operates at faster data transfer rates than the data transfer rate at which near field communication components 24, 26, 32, 34 operate. In still other examples, near field communication components 24, 26, 32, 34 are used for determining bed-to-room location and then bed uses another communications channel, such as a wired connection or wi-fi to wireless access point communication, as the primary communication channel.

30 **[0033]** According to another example, antenna 24 is not mounted on plug 14 but instead, is coupled to some other portion of bed 16. For example, antenna 24 is mounted on a base frame of bed 16 in some examples. In such examples, antenna 26 and its associated circuitry 34 need not be placed near any wall outlet. In this example, the near field communication components 24, 26, 32, 34 operate as a bed docking system which is used for establishing bed-to-room association. The near field communication components 24, 32 may be included in a module that bolts onto, or otherwise mounts, to bed 16 and then components 26, 34 are wall mounted and wired to network 30. This allows for retrofitting existing beds with near field communication components 26, 34, again, for bed-to-room association purposes. The term "wall mounted" is intended to encompass mounting onto a room wall or onto a portion of some other piece of architectural

equipment (e.g., headwall units, columns, arms, carts, chases, bed locators) found in a patient room, as well as mounting on a floor or ceiling. The term wall outlet is intended to cover power outlets mounted to room walls and power outlets mounted on other architectural equipment, a ceiling, or a floor.

5 [0034] According to another feature, the Wi-Fi circuitry 80, 82 is used to support secondary radio communications, such as voice communications or entertainment (e.g., television or radio) audio signal communications, to and from bed 16. In some embodiments, Wi-Fi circuitry 80, 82 operates according to the Bluetooth protocol, although any suitable wireless technology is usable. In some embodiments, the Wi-Fi circuitry 80, 82 uses bed ID and location ID transmitted via antennae 24, 26 to automatically pair up for the secondary radio communications. However, this need not be the case if circuitry 80, 82 is operable to perform the automatic pairing functions themselves. Thus, to give an example, a patient on bed 16 communicates with a caregiver at a remote nurse's station by pressing a nurse call button or switch as is known in the art. The patient's voice is picked up by a microphone on bed 16 and transmitted to the remote nurse's station via circuitry 80, 82 and the caregiver's voice is heard by the patient through a speaker on bed 16 that receives the caregiver's voice audio via circuitry 80, 82. Of course, other circuitry and components, such as network 30 and processor 40 are included in the audio data link between the bed 16 and remote nurse's station in some examples.

10 [0035] Also according to this disclosure, bed 16 configures itself differently based on location ID data transmitted via antenna 26 from module 28 and received by antenna 24. For example, if the location ID indicates that the bed 16 is located in a med/surg room (e.g., a typical patient room) the bed 16 configures its settings in one way and if the location ID indicates that the bed is located in the intensive care unit (ICU), the bed 16 configures its setting in another way. Some screens that are shown on the graphical user interface of bed 16 for control of various features of bed 16 may be enabled or disabled depending upon the location of bed 16. Further according to this disclosure, patient ID data is transmitted from a remote computer of network 30 to bed 16 via antennae 24, 26 and bed 16 configures itself based on patient ID. For example, certain therapies such as continuous lateral rotation therapy (CLRT), alternating pressure therapy, low air loss therapy, and the like may be indicated for the particular patient and bed 16 will enable the appropriate therapy based on the patient ID. Therapies that may be contraindicated, such as, CLRT for a spinal surgery patient, are disabled by bed 16 based on patient ID.

15 [0036] In some examples, the location ID is used by the bed 16 to configure room lighting or to determine the type of television in the room and so forth. It is further contemplated that in some examples, the location ID is used by bed 16 to enable features such as permitting a patient to order and pay for video on demand or to turn on features of a rental bed or to gain access to remote servers or websites for looking up medical information. Data communicated between antenna 24 of bed 16 and antenna 26 of module 28 is used, in some examples, to synchronize display of data from devices 60 on a display of bed 16, or vice versa, and even to provide display information to mobile devices carried by caregivers.

20 [0037] Although certain illustrative embodiments have been described in detail above, many embodiments, variations and modifications are possible.

35 Claims

40 1. An apparatus comprising:

40 a hospital bed (16) comprising an auxiliary power outlet (50);
 a medical device (60); a cable (58) extending from the medical device (60) and having at one end thereof a plug (56) comprising a plug body, a plurality of prongs (54) extending from the plug body and configured to couple to the auxiliary power outlet (50) of the hospital bed (16) to receive power;
 45 characterised in a first near field communication antenna (126) carried by the plug body;
 a communication module coupled to the bed (16) in proximity to the auxiliary power outlet (50), the communication module comprising a second near field communication antenna (124), and at least one of the first near field communication antenna (126) and the second near field communication antenna (124) communicating data wirelessly to the other of the first near field communication antenna (126) and the second near field communication antenna (124); and
 50 near field communication circuitry (134) carried by the medical device (60) and coupled to the first near field communication antenna (126) via at least one conductor (136) routed along the cable (58),

55 wherein the hospital bed (16) receives data from the medical device (60) via the first and second near field communication antennae (124, 126).

2. The apparatus of claim 1, comprising a unit spaced from the bed and wherein the bed (16) is configured to send at least some of the data received from the medical device (60) to a unit spaced from the bed (16).

3. The apparatus of claim 2, wherein the bed (16) has a third near field communication antenna and the unit spaced from the bed (16) has a fourth near field communication antenna, the at least some of the data sent by the bed (16) is transmitted from the third near field communication antenna to the fourth near field communication antenna.
- 5 4. The apparatus of any preceding claim, wherein the first near field communication antenna (126) and the second near field communication antenna (124) are spaced apart by about four centimeters (4 cm) or less when the first near field communication antenna (126) and the second near field communication antenna (124) communicate wirelessly.
- 10 5. The apparatus of any preceding claim, wherein the first near field communication antenna (126) is included in a label that sticks to the plug body.
6. The apparatus of any preceding claim, wherein one of the first and second near field communication antennas (124, 126) serves as a passive target and the other near field communication antenna (124, 126) is coupled to initiator circuitry that actively generates a radio frequency field via the said one near field communication antenna (124, 126) to power up the passive target for data transfer.
- 15 7. The apparatus of any preceding claim, further comprising second communication circuitry coupled to the second near field communication antenna (124), the first and second circuitry communicating via the first near field communication antenna (126) and the second near field communication antenna (124) according to a peer-to-peer protocol.
- 20 8. The apparatus of any preceding claim, further comprising a read/write module carried by the plug body and coupled to the first near field communication antenna (126).
- 25 9. The apparatus of any one of claims 1 to 8, further comprising a read/write module coupled to the second near field communication antenna (124).
- 30 10. The apparatus of any preceding claim, wherein the communication module comprises a housing in close proximity to the auxiliary power outlet (50) and the second near field communication antenna (124) is situated in the housing.
11. The apparatus of claim 10, wherein the housing has an opening through which the plug (56) is inserted to couple to the power outlet (50).
- 35 12. The apparatus of either claim 10 or claim 11, wherein the communication module further comprises a mounting plate that mounts over a cover plate associated with the auxiliary power outlet (50) and the housing couples to the mounting plate.
- 40 13. The apparatus of any preceding claim, wherein the communication module comprises a Nurse Call cancel button.

Patentansprüche

- 45 1. Vorrichtung bestehend aus:
- einem Krankenhausbett (16) mit einer Hilfsstromsteckdose (50);
einer medizinischen Einrichtung (60);
einem Kabel (58), das von der medizinischen Einrichtung (60) ausgeht und an einem Ende mit einem Stecker (56) mit einem Steckerkörper versehen ist, wobei eine Vielzahl von Stiften (54) vom Steckerkörper ausgehen und konfiguriert sind, um die Hilfsstromsteckdose (50) des Krankenhausbettes (16) mit Strom zu versorgen;
50 **gekennzeichnet durch** eine erste Nahfeldkommunikationsantenne (126), die am Steckerkörper angeordnet ist; ein Kommunikationsmodul, das mit dem Bett (16) in der Nähe der Hilfsstromsteckdose (50) verbunden ist, wobei das Kommunikationsmodul eine zweite Nahfeldkommunikationsantenne (124) umfasst und mindestens entweder die erste Nahfeldkommunikationsantenne (126) oder die zweite Nahfeldkommunikationsantenne (124) Daten drahtlos zur jeweils anderen entweder ersten Nahfeldkommunikationsantenne (126) oder zweiten Nahfeldkommunikationsantenne (124) überträgt; und eine Nahfeldkommunikationsschaltung (134), die an der
55 medizinischen Einrichtung (60) angebracht und über mindestens einen entlang des Kabels (58) geführten Leiter (136) mit der ersten Nahfeldkommunikationsantenne (126) verbunden ist,

EP 2 599 435 B1

wobei das Krankenhausbett (16) über die ersten und zweiten Nahfeldkommunikationsantennen (124, 126) Daten von der medizinischen Einrichtung (60) empfängt.

- 5 2. Vorrichtung nach Anspruch 1, mit einem vom Bett abgesetzten Gerät, wobei das Bett (16) so konfiguriert ist, dass mindestens einige der von der medizinischen Einrichtung (60) empfangenen Daten an ein vom Bett (16) abgesetztes Gerät gesendet werden.
- 10 3. Vorrichtung nach Anspruch 2, wobei das Bett (16) eine dritte Nahfeldkommunikationsantenne besitzt und das vom Bett (16) abgesetzte Gerät mit einer vierten Nahfeldkommunikationsantenne versehen ist, wobei die vom Bett (16) gesendeten mindestens einigen Daten von der dritten Nahfeldkommunikationsantenne zur vierten Nahfeldkommunikationsantenne übertragen werden.
- 15 4. Vorrichtung nach irgendeinem der vorhergehenden Ansprüche, wobei die erste Nahfeldkommunikationsantenne (126) und die zweite Nahfeldkommunikationsantenne (124) um ungefähr vier Zentimeter (4 cm) oder weniger voneinander abgesetzt sind, wenn die erste Nahfeldkommunikationsantenne (126) und die zweite Nahfeldkommunikationsantenne (124) drahtlos miteinander in Verbindung stehen.
- 20 5. Vorrichtung nach irgendeinem der vorhergehenden Ansprüche, wobei die erste Nahfeldkommunikationsantenne (126) sich in einem am Steckerkörper angebrachten Aufkleber befindet.
- 25 6. Vorrichtung nach irgendeinem der vorhergehenden Ansprüche, wobei entweder die erste oder die zweite Nahfeldkommunikationsantenne (124, 126) als passives Ziel dient und die jeweils andere Nahfeldkommunikationsantenne (124, 126) mit der Initiatorschaltung verbunden ist, von der über die eine Nahfeldkommunikationsantenne (124, 126) aktiv ein Hochfrequenzfeld generiert wird, um das passive Ziel zum Zwecke der Datenübertragung mit Strom zu versorgen.
- 30 7. Vorrichtung nach irgendeinem der vorhergehenden Ansprüche, mit des Weiteren einer mit der zweiten Nahfeldkommunikationsantenne (124) verbundenen zweiten Kommunikationsschaltung, wobei die erste und die zweite Schaltung gemäß einem Punkt-zu-Punkt-Protokoll über die erste Nahfeldkommunikationsantenne (126) und die zweite Nahfeldkommunikationsantenne miteinander in Verbindung stehen.
- 35 8. Vorrichtung nach irgendeinem der vorhergehenden Ansprüche, mit des Weiteren einem Lese-/Schreibmodul, das sich am Steckerkörper befindet und mit der ersten Nahfeldkommunikationsantenne (126) verbunden ist.
- 40 9. Vorrichtung nach irgendeinem der Ansprüche 1 bis 8, mit des Weiteren einem Lese-/Schreibmodul, das mit der zweiten Nahfeldkommunikationsantenne (124) verbunden ist.
- 45 10. Vorrichtung nach irgendeinem der vorhergehenden Ansprüche, wobei das Kommunikationsmodul in unmittelbarer Nähe der Hilfsstromsteckdose (50) ein Gehäuse umfasst, und wobei die zweite Nahfeldkommunikationsantenne (124) sich in dem Gehäuse befindet.
- 50 11. Vorrichtung nach Anspruch 10, wobei das Gehäuse eine Öffnung aufweist, durch welche der Stecker (56) zur Verbindung mit der Steckdose (50) eingeführt wird.
12. Vorrichtung nach entweder Anspruch 10 oder Anspruch 11, wobei das Kommunikationsmodul des Weiteren eine Montageplatte aufweist, die über einer mit der Hilfsstromsteckdose (50) verbundenen Abdeckplatte angebracht ist, und wobei das Gehäuse an der Montageplatte angebracht ist.
13. Vorrichtung nach irgendeinem der vorhergehenden Ansprüche, wobei das Kommunikationsmodul eine Taste zum Ausschalten der Schwesternruffunktion umfasst.

Revendications

- 55 1. Appareil comprenant :
 - un lit d'hôpital (16) comprenant une prise de courant auxiliaire (50) ;
 - un dispositif médical (60) ;

un câble (58) partant du dispositif médical (60) et comportant à une première de ses extrémités une fiche (56) comprenant un corps de fiche, une pluralité de broches (54) partant du corps de fiche et conçues pour se coupler à la prise de courant auxiliaire (50) du lit d'hôpital (16) pour recevoir du courant électrique ;

caractérisé en ce qu'il comporte

une première antenne de communication en champ proche (126) portée par le corps de fiche ;
 un module de communication couplé au lit (16) à proximité de la prise de courant auxiliaire (50), le module de communication comprenant une deuxième antenne de communication en champ proche (124), et au moins l'une de la première antenne de communication en champ proche (126) et de la deuxième antenne de communication en champ proche (124) transmettant des données en mode sans fil à l'autre de la première antenne de communication en champ proche (126) et de la deuxième antenne de communication en champ proche (124) ; et
 un circuit de communication en champ proche (134) porté par le dispositif médical (60) et couplé à la première antenne de communication en champ proche (126) par l'intermédiaire d'au moins un conducteur (136) acheminé le long du câble (58),
 dans lequel le lit d'hôpital (16) reçoit des données du dispositif médical (60) par l'intermédiaire des première et deuxième antennes de communication en champ proche (124, 126).

2. Appareil selon la revendication 1, comprenant une unité espacée du lit et dans lequel le lit (16) est conçu pour envoyer au moins une partie des données reçues du dispositif médical (60) à une unité espacée du lit (16).
3. Appareil selon la revendication 2, dans lequel le lit (16) possède une troisième antenne de communication en champ proche et l'unité espacée du lit (16) possède une quatrième antenne de communication en champ proche, l'au moins une partie des données envoyées par le lit (16) sont transmises de la troisième antenne de communication en champ proche à la quatrième antenne de communication en champ proche.
4. Appareil selon l'une quelconque des revendications précédentes, dans lequel la première antenne de communication en champ proche (126) et la deuxième antenne de communication en champ proche (124) sont espacées l'une de l'autre d'environ quatre centimètres (4 cm) ou moins lorsque la première antenne de communication en champ proche (126) et la deuxième antenne de communication en champ proche (124) communiquent en mode sans fil.
5. Appareil selon l'une quelconque des revendications précédentes, dans lequel la première antenne de communication en champ proche (126) est incluse dans une étiquette qui est collée sur le corps de la fiche.
6. Appareil selon l'une quelconque des revendications précédentes, dans lequel l'une des première et deuxième antennes de communication en champ proche (124, 126) sert de cible passive et l'autre antenne de communication en champ proche (124, 126) est couplée à un circuit déclencheur qui génère de manière active un champ de radiofréquence par l'intermédiaire de ladite antenne de communication en champ proche (124, 126) pour mettre sous tension la cible passive pour un transfert de données.
7. Appareil selon l'une quelconque des revendications précédentes, comprenant en outre un second circuit de communication couplé à la deuxième antenne de communication en champ proche (124), les premier et second circuits communiquant par l'intermédiaire de la première antenne de communication en champ proche (126) et de la deuxième antenne de communication en champ proche (124) selon un protocole de pair à pair.
8. Appareil selon l'une quelconque des revendications précédentes, comprenant en outre un module de lecture et d'écriture porté par le corps de fiche et couplé à la première antenne de communication en champ proche (126).
9. Appareil selon l'une quelconque des revendications 1 à 8, comprenant en outre un module de lecture et d'écriture couplé à la deuxième antenne de communication en champ proche (124).
10. Appareil selon l'une quelconque des revendications précédentes, dans lequel le module de communication comprend un boîtier à proximité immédiate de la prise de courant auxiliaire (50) et la deuxième antenne de communication en champ proche (124) est située dans le boîtier.
11. Appareil selon la revendication 10, dans lequel le boîtier comporte une ouverture à travers laquelle on introduit la fiche (56) pour la coupler à la prise de courant (50).

EP 2 599 435 B1

12. Appareil selon la revendication 10 ou la revendication 11, dans lequel le module de communication comprend en outre une plaque de fixation qui se fixe sur une plaque de protection associée à la prise de courant auxiliaire (50) et le boîtier se couple à la plaque de fixation.

5 13. Appareil selon l'une quelconque des revendications précédentes, dans lequel le module de communication comprend un bouton d'annulation d'appel infirmière.

10

15

20

25

30

35

40

45

50

55

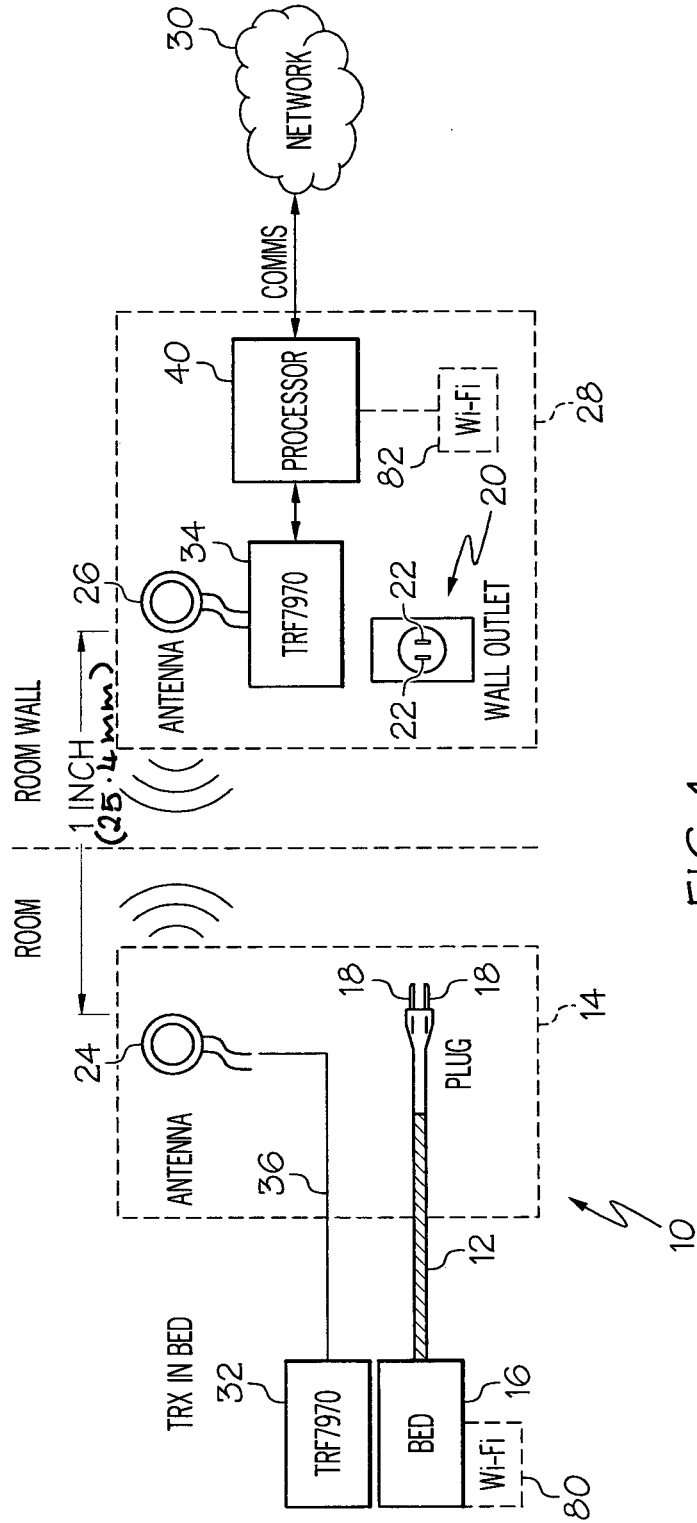

FIG. 1

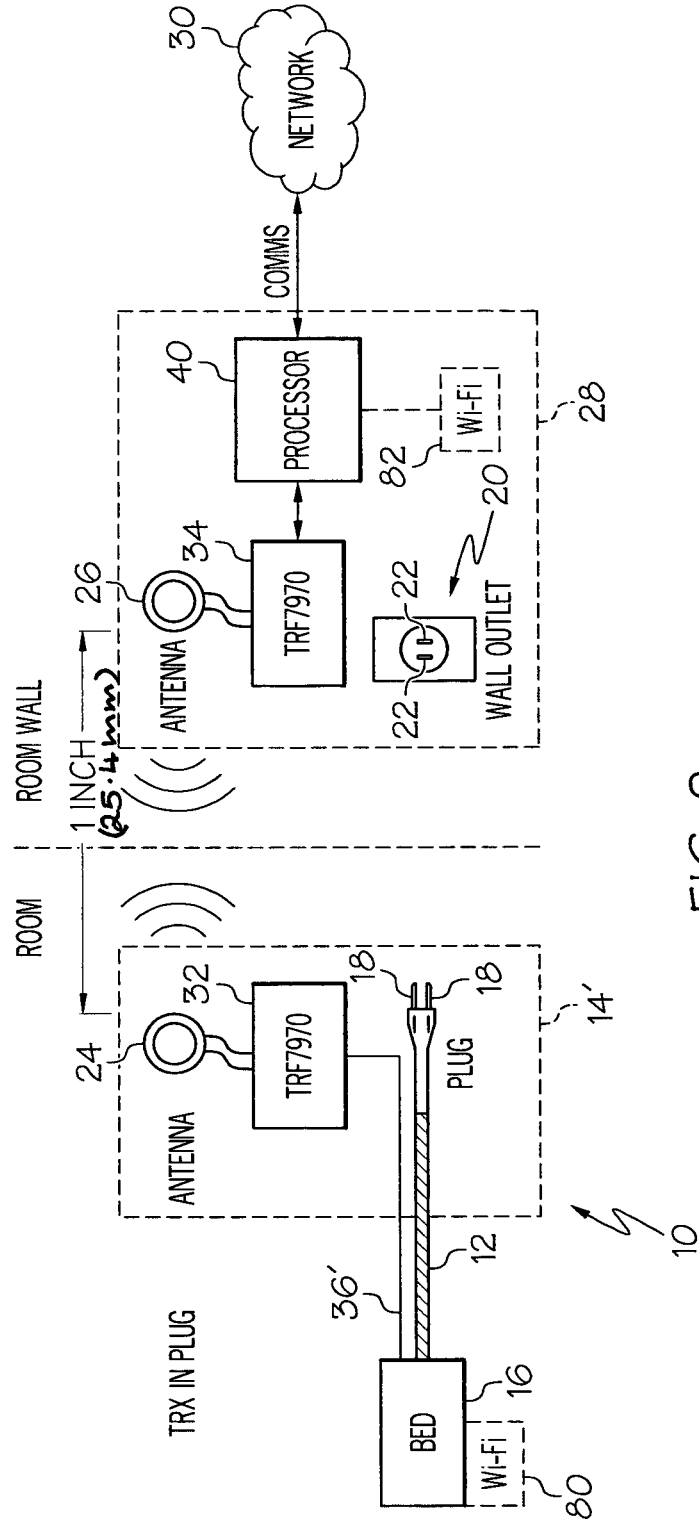

FIG. 2

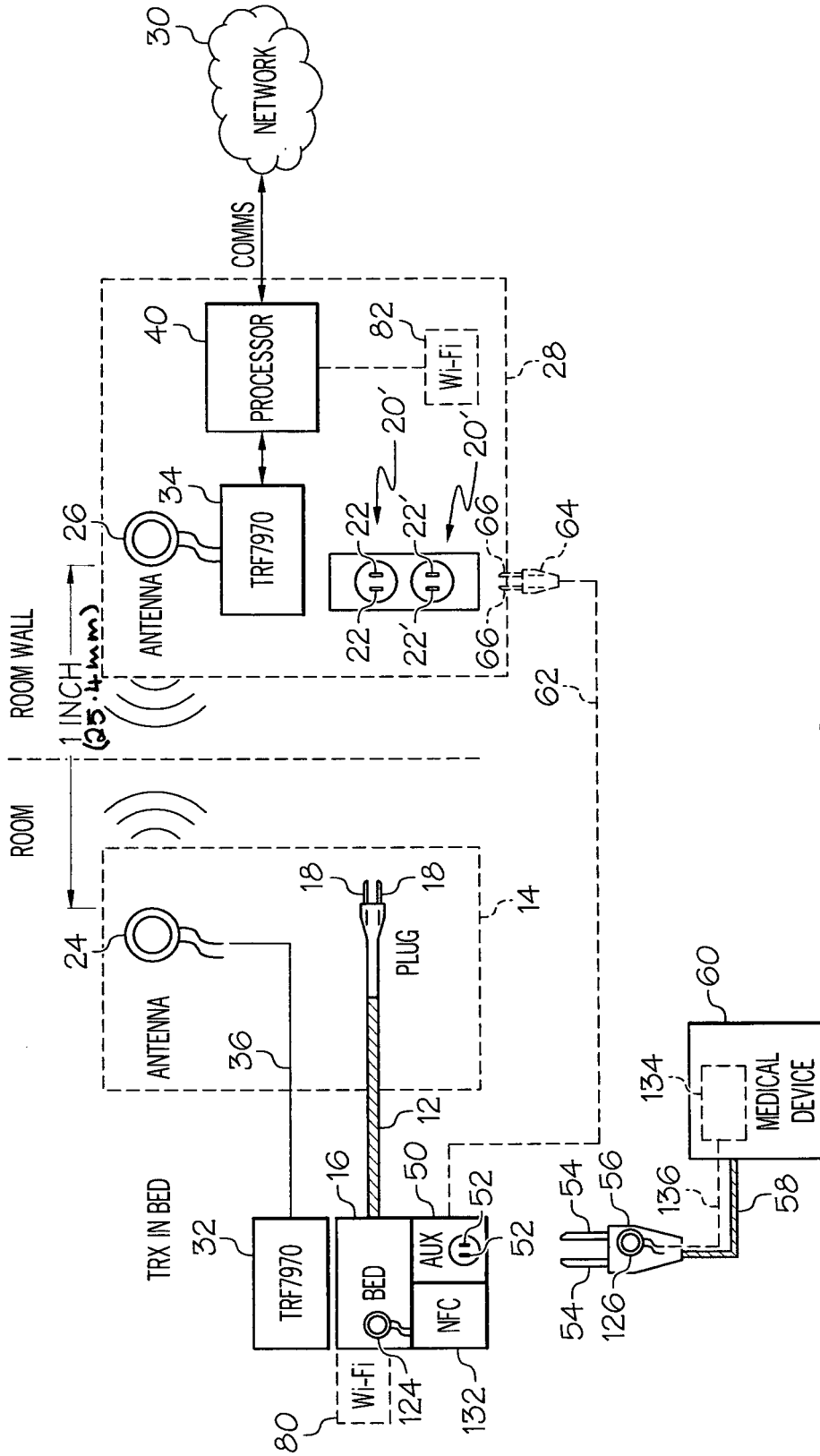

FIG. 3

REFERENCES CITED IN THE DESCRIPTION

This list of references cited by the applicant is for the reader's convenience only. It does not form part of the European patent document. Even though great care has been taken in compiling the references, errors or omissions cannot be excluded and the EPO disclaims all liability in this regard.

Patent documents cited in the description

- US 7399205 B [0002] [0017] [0018] [0019]
- US 5398149 A [0003]
- JP 2010153367 B [0003]
- US 7746218 B [0012]
- US 7538659 B [0012]
- US 7319386 B [0012]
- US 7242308 B [0012]
- US 6897780 B [0012]
- US 6362725 B [0012]
- US 6147592 A [0012]
- US 5838223 A [0012]
- US 5699038 A [0012]
- US 5561412 A [0012]
- US 20090217080 A [0012]
- US 20090214009 A [0012]
- US 20090212956 A [0012]
- US 20090212925 A [0012]
- US 7515059 B [0024]
- US 7330127 B [0024]
- US 6721980 B [0024]
- US 20100101022 A [0024]

专利名称(译)	医院病床具有近场通信能力		
公开(公告)号	EP2599435B1	公开(公告)日	2017-09-27
申请号	EP2012194875	申请日	2012-11-29
[标]申请(专利权)人(译)	希尔 - 罗姆服务股份有限公司		
申请(专利权)人(译)	HILL-ROM SERVICES , INC.		
当前申请(专利权)人(译)	HILL-ROM SERVICES , INC.		
[标]发明人	DIXON STEVEN ALAN HUSTER KEITH A SCHUMAN RICHARD JOSEPH LACK CHRISTOPHER K HEIL THOMAS F		
发明人	DIXON, STEVEN ALAN HUSTER, KEITH, A VANDERPOHL, IRVIN, JOHN III SCHUMAN, RICHARD, JOSEPH LACK, CHRISTOPHER, K HEIL, THOMAS, F		
IPC分类号	H01Q1/00 H01Q1/44 H04W4/00 A61B5/00		
CPC分类号	G08B23/00 A61B5/002 A61B5/6891 H01Q1/007 H01Q1/44 H04B5/0031 H04B5/0056 H04B5/0093 H04L67/104 H04W4/80		
优先权	61/564466 2011-11-29 US		
其他公开文献	EP2599435A1		
外部链接	Espacenet		

摘要(译)

公开了一种用于向位于具有电源插座的房间中的设备 (16) 提供数据通信和电源的装置。例如, 电源插座 (20) 可以是标准AC插座。该装置包括从装置延伸的电缆 (12,36), 并具有包括插头主体 (14) 的插头 (10)。插脚 (18) 从插头主体 (14) 延伸并连接到电源插座 (20) 以接收电力。第一近场通信天线 (24) 由插头主体 (14) 承载。通信模块具有第二近场通信天线 (26) 并且位于插头 (10) 附近的房间中。近场通信天线 (24,16) 中的至少一个无线地将数据传送给另一个。因此, 仅需要一个连接器来向设备 (16) 提供电力和数据。

TABLE 1

0x04 Bed Inputs Messages		Description	1	2	3	4	5	6
Bed Status	Basic							
	Brake Status	Brake set, brake not set	X	X	X	X	X	X
	Surface Prevent Mode	Not activated, activated	X	X				X
	Bed Exit or PPM Armed	Armed, not armed	X	X	X	X	X	X
	Bed Low Position	Bed not down, bed down	X	X	X	X	X	X
	Both Headrails Up	Not down, down	X	X	X	X	X	X
	Both Footrails Up	Not down, down	X	X	X	X	X	X
	PPM							
	PPM Mode - Positioning	Not selected, mode selected	X	X	X	X		
	PPM Mode-Exiting	Not selected, mode selected	X	X	X	X		
Enhanced Bed Status	PPM Mode - Patient Out of Bed	Not selected, mode selected	X	X	X	X		
	PPM or Bed Exit Alarming	Alarming, not alarming	X	X	X	X		
	Rails							
	Right Headrail Position	Not down, down		X	X	X		
	Left Headrail Position	Not down, down		X	X	X		
	Right Footrail Position	Not down, down		X	X	X		
	Left Footrail Position	Not down, down		X	X	X		
	Lockouts							
	Head Motor Lockout	Not locked, locked	X	X	X	X		
	Knee Motor Lockout	Not locked, locked	X	X	X	X		
Enhanced Bed Status	High-Low Motor Lockout	Not locked, locked	X	X	X	X		
	All Motor Lockout	Not locked, locked	X	X	X	X		
	Wound Surface							
	Surface Turn Assist Left Mode	Not active, active	X	X				
	Surface Turn Assist Right Mode	Not active, active	X	X				
	Surface Max Inflate Mode	Not active, active	X	X				
	Heel Suspension Mode	Not active, active	X	X				
	Pulmonary Surface							
	Rotation Mode	Not active, active	X					
	Opti-Rest Mode	Not active, active	X					
Maintenance Alerts	Percussion	Not active, active	X					
	Vibration	Not active, active	X					
	Battery Status Modes, 2 bits	0% charged or disconnected	X	X				
		Not fully charged	X	X				