



(11) **EP 2 493 371 B1**

(12) **EUROPEAN PATENT SPECIFICATION**

(45) Date of publication and mention of the grant of the patent:  
**26.08.2015 Bulletin 2015/35**

(21) Application number: **10828796.2**

(22) Date of filing: **21.10.2010**

(51) Int Cl.:  
**A61B 5/00 (2006.01)**

(86) International application number:  
**PCT/US2010/053559**

(87) International publication number:  
**WO 2011/056454 (12.05.2011 Gazette 2011/19)**

(54) **SKIN AND WOUND ASSESSMENT TOOL**

WERKZEUG ZUR HAUT- UND WUNDENÜBERPRÜFUNG

OUTIL D'ÉVALUATION DE LA PEAU ET DES LÉSIONS

(84) Designated Contracting States:  
**AL AT BE BG CH CY CZ DE DK EE ES FI FR GB GR HR HU IE IS IT LI LT LU LV MC MK MT NL NO PL PT RO RS SE SI SK SM TR**

(30) Priority: **27.10.2009 US 606773**

(43) Date of publication of application:  
**05.09.2012 Bulletin 2012/36**

(60) Divisional application:  
**15177087.2**

(73) Proprietor: **Estocado, Nancy Ann**  
**Las Vegas, NV 89130 (US)**

(72) Inventor: **Estocado, Nancy Ann**  
**Las Vegas, NV 89130 (US)**

(74) Representative: **WSL Patentanwälte Partnerschaft mbB**  
**Kaiser-Friedrich-Ring 98**  
**65185 Wiesbaden (DE)**

(56) References cited:  
**WO-A1-2005/002438 JP-A- 2003 000 568**  
**US-A- 4 483 075 US-A1- 2008 234 552**  
**US-B2- 7 376 456**

- **RUSSELL L: "The importance of wound documentation and classification", BRITISH JOURNAL OF NURSING, ALLEN, LONDON, GB, vol. 8, no. 20, 1 January 1999 (1999-01-01), pages 1342-1354, XP003009322, ISSN: 0966-0461**
- **Andreas M Fette: "A clinimetric analysis of wound measurement tools", , 31 January 2006 (2006-01-31), XP002726737, Retrieved from the Internet: URL:http://www.worldwidewounds.com/2006/january/Fette/Clinimetric-Analysis-Wound-Measurement-Tools.html [retrieved on 2014-07-07]**

Note: Within nine months of the publication of the mention of the grant of the European patent in the European Patent Bulletin, any person may give notice to the European Patent Office of opposition to that patent, in accordance with the Implementing Regulations. Notice of opposition shall not be deemed to have been filed until the opposition fee has been paid. (Art. 99(1) European Patent Convention).

**EP 2 493 371 B1**

**Description**

## COPYRIGHT AUTHORIZATION

**[0001]** A portion of the disclosure of this patent document contains material which is subject to copyright protection. The copyright owner has no objection to the facsimile reproduction by anyone of the patent document or the patent disclosure, as it appears in the Patent and Trademark Office patent file or records, but otherwise reserves all copyright rights whatsoever.

## FIELD OF THE INVENTION

**[0002]** The present invention relates generally to assessment tools. More particularly, various embodiments disclose an L-shaped measuring tool that facilitates easy and consistent categorizations of patient wounds.

## BACKGROUND OF THE INVENTION

**[0003]** The accurate and consistent diagnosis of patient health parameters is essential for the proper staging and treatment of the patient. Consistency in measurement results over time for a single patient is vital to ensure that the actual progress or degradation of the health of the patient is being properly determined. Consistency in measurement results across patients is also vital to ensure that treatment protocols and their underlying data are applied consistently from patient to patient.

**[0004]** Many types of patient health criteria may be classified along a sliding scale depending upon the severity of the affliction. For example, burns have a classification scale of severity ranging from first degree (least severe) up to third degree (most severe). Other classification scales exist for other types of afflictions, such as the Wagner's Scale for foot ulcers, the Payne Martin Classification for skin tears, and the National Pressure Ulcer Advisory Panel (NPUAP) Pressure Ulcer Staging System. Each of these classification scales has a known and accepted classification system that permits a practitioner to assess an affliction against certain predefined standards and assign to the affliction a classification value corresponding to one of a plurality of ranks along the severity scale. Changes of this value in time thus correspond to improving or deteriorating conditions of the affliction and permit the rapid assessment of patient health and progress. It is therefore critical for staging and treatment purposes that clinicians be able to accurately and consistently assess an affliction and classify it into its proper rank along a known scale for that affliction.

**[0005]** "The importance of wound documentation and classification" by L. Russell., British Journal of Nursing, Allen, London, GB, Vol. 8, No. 20, January 1, 1999, p. 1342-1054, provides a summary of known wound classification procedures. Wound assessment is described by evaluation encompassing color classification, wound measurement and classification of tissue type present in

the wound. Numerous methods of measuring wounds are cited, ranging from the simple, such as manual estimation by means of a ruler or wound tracing, to the more technical procedures, e.g. computer, image analysis and color imaging using hue saturation and intensity. Photography, in conjunction with nursing notes, is referred to as a good form of wound documentation.

**[0006]** "A clinimetric analysis of wound measurement tools" by A. M. Fette, January 31, 2006, XP-002726737, refers to methods of measuring wounds, which are assessed by using clinimetrics, which emphasizes the quantitative measurement of clinical data through accurate measurement and data collection.

**[0007]** US 4,483,075 A describes an apparatus and a method for using the same for determining the height and volume of a hematoma structure on the skin surface and for further determining the depth and area of a wound, particularly a crater-type wound on the skin's surface. The apparatus is primarily constructed with a first elongated member having incremental markings thereon and a second member having four radially outward extending arms with incremental markings thereon throughout the length of the radially extending arms where adjacent arms are disposed at 90 degrees angles from one another and a first and second member engaged one to the other and disposed perpendicularly.

**[0008]** Accordingly, there is an immediate need for assessment measuring tools that permit a practitioner to accurately and consistently classify an affliction.

## SUMMARY OF THE INVENTION

**[0009]** In one aspect an L-shaped diagnostic tool according to claim 1 is disclosed. The diagnostic tool comprises a first arm and a second arm joined in an L-shaped configuration. A top surface of the first arm includes a graphical ranking guide, which has a plurality of images that graphically illustrate salient rank classifier indicia for a classification system. Each of the images corresponds to at least one of the ranks within the classification system. In preferred embodiments, each of the ranks has at least one corresponding image, and the images are color images.

**[0010]** In certain preferred embodiments the top surface of the second arm includes a descriptive ranking guide, which has a plurality of rank descriptors that contain text describing salient rank classifier indicia for each of the ranks.

**[0011]** In particularly preferred embodiments the L-shaped tool is provided by a paper substrate, and the bottom surface of the paper substrate comprises a pressure-sensitive adhesive.

**[0012]** Preferred embodiments of the diagnostic tool also include a first ruler and a second ruler respectively disposed on the first arm and the second arm, the origins of which are co-aligned at the internal corner of the L-shaped device.

**[0013]** In certain embodiments the top surface of the

first arm or the second arm may further comprise one or more fields configured for the notational entry of subject and/or assessment information.

**[0014]** In another aspect a diagnostic method according to claim 11 is disclosed. A practitioner obtains an embodiment L-shaped diagnostic tool and places the tool adjacent to an affliction so that the arms extend around the affliction but preferably do not touch the affliction. The practitioner then takes a picture that is framed to include the affliction and at least a portion of the L-shaped diagnostic tool. The graphical ranking guide, the descriptive ranking guide or both are used to determine a rank of the affliction within the classification system.

**[0015]** In certain embodiments a print of the picture is made and the print is attached to a form or chart of the subject suffering from the affliction.

**[0016]** In yet other embodiments the first ruler, the second ruler or both are used to estimate one or more of the area of the affliction, extent of the affliction along the first arm, and extent of the affliction along the second arm.

#### BRIEF DESCRIPTION OF THE DRAWINGS

##### **[0017]**

Fig. 1 is a top view of an embodiment diagnostic device.

Fig. 2 is a detailed view of a first arm of the device shown in Fig. 1.

Fig. 3 is a detailed view of a second arm of the device shown in Fig. 1.

Fig. 4 is a bottom schematic view of the device shown in Fig. 1.

Fig. 5 illustrates use of an embodiment device with a subject.

Fig. 6 illustrates a method employing an embodiment device.

Fig. 7 is a functional diagram of an embodiment digital camera.

Figs. 8A-8C show back views of the camera of Fig. 7 with image manipulation being performed by a user according to an embodiment assessment method.

#### DETAILED DESCRIPTION

**[0018]** For purposes of the following, a "subject" is any person, animal, plant, system or the like upon which measurements may be made.

**[0019]** An "affliction" broadly includes a wound, skin abnormality, blemish, disease, state or condition exhibited by a subject that may exhibit one or more measurable

symptoms or characteristics.

**[0020]** A "clinician" or "practitioner" is a person that takes measurements of a subject, and may include a doctor, nurse, physical therapist, laboratory personnel or the like.

**[0021]** A "value" includes a number, letter, symbol, word or the like.

**[0022]** A "classification system" is an assessment procedure that permits a clinician to assign a value to an affliction based upon one or more measurable symptoms or characteristics. Each value corresponds to one of a plurality of ranks, each rank being associated with a predefined state or condition of the affliction. Ranks, and their corresponding values, are typically ordered by severity or the like. By way of example, classification systems include the burn classification system, the Wagner's Scale for foot ulcers, the Payne Martin Classification for skin tears, the NPUAP pressure ulcer staging system, the Center for Disease Control (CDC) Surgical Wound Classifications, Bruise Classification, Primary Lesions and Secondary Lesions.

**[0023]** "Rank classifier indicia" include one or more symptoms or characteristics of an affliction when in a state or condition corresponding to a rank. Rank classifier indicia may be indicated graphically through illustrations, photographs and the like, as well as textually.

**[0024]** Specific reference is made in the following to the medical fields, for which particularly preferred embodiment devices are adapted, but it should be understood that other embodiment devices may be more widely employed and may not be limited to only the field of medical assessment.

**[0025]** As known in the field of assessments and diagnostics, and in the medical fields in particular, afflictions of a specific type may be encountered in wide degrees of various states of intensity or severity. Predefined classification systems exist that permit a clinician or practitioner to "pigeon hole" a patient's affliction into a rank based upon severity and thereby record a corresponding value into the patient's chart. Each rank in the classification system is typically characterized by corresponding rank classifier indicia that clinicians or practitioners are familiar with and against which clinicians or practitioners compare the affliction to determine the corresponding rank. An embodiment assessment classification device 10 is shown in Fig. 1, which permits rapid, accurate and repeatable rank determinations by clinicians or other users of the device 10.

**[0026]** By way of specific example, the diagnostic classification device 10 is configured to permit the classification skin tissue wounds. It will be appreciated that devices configured to permit the classification of other types of afflictions are possible. Skin pressure ulcer wounds are typically classified into six or more ranks. These ranks may be ordered by the severity of the skin tissue wound and include, in order, healed, stages one to four, suspected deep tissue injury (DTI), and unstageable. "Healed" is the degenerate case in which there is no tis-

sue wound or normal skin, and the corresponding rank classifier indicia would be those characteristics of normal skin.

**[0027]** Rank classifier indicia for stage I wounds include intact skin with localized, non-blanchable redness that is typically over a bony prominence. It is noted that with respect to darkly pigmented skin, the corresponding stage I rank classifier indicia may not include visible blanching, although the color of the wound may differ from the surrounding area. Additional stage I rank classifier indicia pain in the area, or the are being softer, warmer or cooler than the surrounding tissue.

**[0028]** Corresponding rank classifier indicia for stage II wounds include a partial loss of thickness of the dermis, which presents as a shallow open ulcer having a smooth reddish or pinkish wound bed, but the wound itself presents without slough. Stage II rank classifier indicia may also include an open or ruptured, serum-filled blister. Additional stage II rank classifier indicia include a shiny or dry, shallow ulcer without slough or bruising.

**[0029]** Stage III rank classifier indicia may include full thickness tissue loss, including visible subcutaneous fat, and/or moist, red, bubbly granulation tissue, but not including exposed visible bone, tendon or muscle. Sloughing may be part of stage III rank classifier indicia so long as it does not obscure the depth of tissue loss. Undermining and tunneling are also suitable rank classifier indicia. It will be appreciated that rank classifier indicia may vary depending upon the location of the affliction upon the subject. For example, the depth of a stage III pressure ulcer may vary by anatomical location, and thus corresponding rank classifier indicia may include anatomical position in the context of other symptoms or characteristics.

**[0030]** Stage IV rank classifier indicia include full thickness tissue loss with exposed bone, tendon or muscle. Other rank classifier indicia include slough or eschar in some regions of the wound bed. Undermining and tunneling may also be suitable stage IV rank classifier indicia.

**[0031]** DTI rank classifier indicia include intact skin with purple, maroon or the like coloration, or a blood-filled blister arising from damaged underlying soft tissue arising from pressure, shear or both. Additional rank classifier indicia include pain, or tissue that is firmer, cooler, or warmer, than the adjacent tissue, or that is mushy or boggy. Suitable rank classifier indicia may not be pronounced or obvious in subjects with dark skin tones. Additional rank classifier indicia may include the evolution of the wound, and in particular a thin blister over a dark wound bed that evolves to become covered by thin eschar.

**[0032]** Rank classifier indicia for the unstageable rank include full thickness tissue loss in which the base of the ulcer is covered by slough (which may be yellow, tan, gray, green or brown) and/or eschar (which may be tan, brown or black) in the wound bed. This ranking may be used as a placeholder until enough slough and/or eschar

is removed to expose the base of the wound, after which the true depth, and therefore proper stage as characterized above, of the wound may be determined.

**[0033]** Referring again to Fig. 1 in the context of the above-described rank classifier indicia, the device 10 is L-shaped, having a first arm 12 and a second arm 14 that preferably meet at a right angle. An internal origin 16 and an external origin 18 are thereby respectively created by the meeting of the first arm 12 and second arm 14. More specifically, the internal origin 16 is formed by the intersection of the respective internal edges 11 and 13 of the first arm 12 and the second arm 14. Similarly, the external origin 18 is formed at the intersection of the respective external edges 17 and 19 of the first arm 12 and the second arm 14. The L-shaped device 10 is formed from a substrate 20 having a top surface 21 and a bottom surface. The top surface 21 is shown in Fig. 1. The substrate 20 is preferably made from a clean, disposable, single patient use material. More preferably, the substrate 20 is made from paper. In certain preferred embodiments the device 10 meets the requirements for using "clean technique" versus "sterile technique" procedures due to the fact that most wounds are contaminated and thus do not require the more stringent sterile technique protocols. However, other embodiment devices 10 may conform to such "sterile technique" protocols to accommodate, for example, new incision-type wounds made in an operating room, or to accommodate devices 10 placed within a sterile packaging kit, as may be done, for example, with negative wound therapy dressing kits. Devices 10 may therefore be manufactured in accordance with sterile technique methods in a certified sterilization facility and may thus be used, packaged and labeled per national standards. However, other or additional substrate 20 materials are possible, such as coating the top surface, bottom surface or both of the device 10 with antimicrobial or antiseptic agents, such as Silver AG+, Hydroferra Blue, Chlorhexidine Gluconate, Dakins, Acetic Acid, Betadine, Aluminum Salts and the like. The device 10 may also be laminated with an approved-see through covering that may be disinfected between patient use.

**[0034]** A detailed view of the top surface 21 of the first arm 12 is shown in Fig. 2. The top surface 21 of the first arm 12 may include a first ruler 22, which is preferably immediately adjacent to, and runs along, the internal side 11. The first ruler 22 may be formed by any suitable means, but is preferably formed by ink markings. The origin (or zero-point) of the first ruler 22 may be advantageously aligned with the internal origin 16.

**[0035]** The top surface 21 of the first arm 12 also includes a graphical ranking guide 30. The graphical ranking guide 30 includes a plurality of graphical images 32, which are preferably color photographs or color illustrations, although it will be appreciated that any suitably clear, representative images as discussed in the following may be utilized. Color images are highly preferred, however, as they uniquely and intuitively provide color

information that may be highly relevant to rank classifier indicia. Color graphical images 32 provide the unappreciated benefit of more consistent and reproducible affliction rank classifications by practitioners, which is highly desirable for patient health and treatment purposes. Each graphical image 32 corresponds to a rank in the classification system for the affliction to be diagnosed with the aid of device 10. Each rank in the classification system is preferably provided at least one corresponding graphical image 32, and as shown in Figs. 1 and 2 may in some cases include two or more representative images 32. Each graphical image 32 graphically presents to the practitioner rank classifier indicia that is representative for that rank corresponding to the image 32. Adjacent to each graphical image 32, or groups of graphical images 32, may be a corresponding rank title indicator 34, which indicates the name of that rank for the corresponding graphical image(s) 32. By way of example, below rank title indicator 34 "Healed" is a graphical image 32 of normal skin, which corresponds to the "Healed" rank for the wound classification system employed by the device 10. Similarly, two graphical images 32 are shown, each corresponding to a stage two wound, above each of which is provided the rank title indicator 34 "STG. 2", indicating the rank of stage two. In the same vein, graphical images 32 are provided for stages one, three and four, as well as DTI and unstageable wounds, for each of which is further included a corresponding rank title indicator 34.

**[0036]** A detailed view of the top surface 21 of the second arm 14 is shown in Fig. 3. The top surface 21 of the second arm 14 may include a second ruler 24, which is preferably immediately adjacent to, and runs along, the internal side 13 of the second arm 14. The second ruler 24 may be formed in the same manner as the first ruler 22. The origin (or zero-point) of the second ruler 24 may be advantageously aligned with the internal origin 16. The first ruler 22 and the second ruler 24 thus provide a convenient Cartesian coordinate system that may be used to measure, for example, the area of an affliction, the extent of the affliction along the first arm 12, and the extent of the affliction along the second arm 14.

**[0037]** The top surface 21 of the second arm 14 also includes a descriptive ranking guide 40. The descriptive ranking guide 40 includes a plurality of rank descriptors 42 that contain text describing the salient features of the respective rank classifier indicia for that rank. Each rank descriptor 42 corresponds to a rank in the classification system for the affliction to be diagnosed with the aid of device 10. Each rank in the classification system is preferably provided at least one corresponding rank descriptor 42, but in some cases two or more ranks may share portions of a common rank descriptor 42, as shown in Figs. 1 and 3. Each rank descriptor 42 has text that describes to the practitioner the most significant rank classifier indicia that is representative for that rank or group of ranks corresponding to the descriptor 42. Adjacent to, or with, each rank descriptor 42 may be a corresponding rank title indicator 44, which indicates the name of that

rank, or group of ranks, for the corresponding rank descriptor 42. By way of example, below rank title indicator 44 "Stage 3 or 4" is text describing the most salient features common to Stage 3 ranked and Stage 4 ranked afflictions in the wound classification system; also included are descriptors that are respectively specific to Stage 3 ranked afflictions and Stage 4 ranked afflictions. In contrast, Stage 1 and Stage 2 ranks each have their own rank descriptor 42 and corresponding rank title indicators 44.

**[0038]** As shown in Figs. 2 and 3 the device 10, and preferably the top surface 21 of the device 10, may include additional information, and in particular may include lines, boxes or forms that may be filled in by the practitioner. For example, the device 10 may include brief instructions for use 51, a date field 52, a subject initial field 53, a subject location field 54, an anatomical position (the device 10 is preferably positioned at 12 O'clock on the subject to standardize the method) field 55, an affliction location (body part) field 56 (i.e., where the affliction is located on the subject), a field for the name of the practitioner 57 and so forth.

**[0039]** It will be appreciated that the embodiment device 10 is not limited to merely one categorization system. It is possible, for example, to provide the first arm 12 with a graphical ranking guide and corresponding descriptive ranking guide for a first classification system, and provide the second arm 14 with a graphical ranking guide and corresponding descriptive ranking guide for a second classification system. Variations on this theme are also possible. By way of specific example, the embodiment device 10 includes the graphical ranking guide 30 and corresponding descriptive ranking guide 40 for the NP-UAP Pressure Ulcer Staging System. However, first arm 12 further includes an abbreviated descriptive ranking guide 59 for "Other" skin problems. The abbreviated ranking guide 59 may simply include, for example, rank title indicators and appropriate spacers 58, as discussed below. Generally speaking, all skin wounds may be divided into either pressure wounds, which may then be categorized as indicated above, or "Other" types of wounds, which have their own categorization system. The "Other" categorization system has three ranks for wounds, which may be labeled superficial, partial thickness and full thickness. Rank classifier indicia for the "superficial" rank include intact skin with redness of a localized area or damage to the epidermis layer of skin. Rank classifier indicia for "partial thickness" include damage to the epidermis and dermis layers of the skin; such damage may be superficial and presents as a red, smooth, shallow crater, abrasion or serum-filled blister. Rank classifier indicia for "full thickness" include damage through the skin to the subcutaneous layer of skin and even to the structures of muscle tendon or bone; it may present as a deep crater and may even tunnel into surrounding subcutaneous tissue.

**[0040]** As shown in Fig. 2, the abbreviated descriptive ranking guide 59 of the second classification system may

be positioned and designed so as to align with the graphical ranking guide 30 of the first classification system; in this manner rank classifier indicia common to both systems may be beneficially employed on the device 10. For example, as shown in the device 10, one or more images 32 from one or more ranks in a finely-grained first classification system may be shared to illustrate a single rank in a coarsely-grained second classification system 59. The appropriate grouping of images 32 for each rank in the coarsely-grained second classification system 59 may be indicated by spacers 58 or the like, such as arrows or any other suitable grouping indicator.

**[0041]** Fig. 4 shows the bottom surface 29 of the embodiment device 10. As illustrated in Fig. 4, the bottom surface 29 of the substrate 20 preferably includes a low-tack, pressure sensitive adhesive 25, such as is used on sticky notes, EKG electrodes, transdermal drug patches and the like. Other tacky surfaces may be used, such as silicone, or no tacky surfaces may be used if there is a known allergy to adhesive or silicone products. Any suitable adhesive may be used as known in the art. The device 10 preferably meets guidelines and is labeled as a "latex free" product. In preferred embodiments the adhesive 25 is a strip approximately 20 cm long and 4 cm wide that runs immediately adjacent to the external edges 17, 19 of the substrate 20. It will be appreciated, however, that other placements and locations of the adhesive 25 are possible. For example, the adhesive 25 could be positioned to run adjacent to the internal edges 11, 13 of the substrate 20. Or, the adhesive 25 may cover the entire bottom surface 29.

**[0042]** Fig. 5 illustrates how the embodiment device 10 may be used with a subject 100. With further reference to Fig. 5, the device 10 may be positioned so that the arms 12, 14 extend around, but do not touch, an affliction 102 of a subject 100. It will be appreciated that the adhesive 25 on the bottom surface 29 of the device 10 may assist in such placement, and keeps the device 10 in position while, for example, a photograph is being taken. The practitioner may refer to the graphical ranking guide 30 and select a rank for the affliction based upon the graphical image 32 and descriptor 42 that most closely match the affliction 102, as optionally suggested by instructions 51. The practitioner may then record his or her assessment of the ranked value for the affliction 102 on, for example, the device 10 itself in a suitable field, or by circling the appropriate rank title indicator or image 32, by entry of the value into a separate form or the like. The practitioner may further record other relevant information where indicated, such as date, practitioner name, affliction location and so forth directly onto the related fields on the top surface 21.

**[0043]** Fig. 6 illustrates a particularly preferred method for using the embodiment device 10. In a preferred embodiment method, the practitioner positions the device 10 in contact with the subject to extend around the affliction 102 as described above, and then takes a picture of the affliction 102 with the device 10 visible in the picture

around the affliction 102. It will be appreciated that the adhesive 25 keeps the device 10 in contact with the subject, which is convenient for the photography step. Preferably at least the internal origin 16, the first ruler 22 and second ruler 24 are visible in the resultant picture, together with the affliction 102 itself. The picture is then printed in any standard manner and the resultant print 202, which is preferably a color print, is affixed to a form 200, such as with tape, glue, staples or the like, which may then be incorporated into a chart for the subject 100. The print 202 may be used to assist a practitioner in the filling out of fields on the form 200, and provides clear, intuitive evidence of the affliction 102 and the bases for any analysis and diagnosis present in the form 200. Further, as indicated in Fig. 6, a practitioner may mark up the print 202 with lines extending perpendicularly from the arms 12, 14 to the extreme extents of the affliction 102 to approximately assess the surface area of the affliction 102.

**[0044]** Particularly preferred embodiment devices 10 are made from a paper substrate 20, and all graphical and textual information present on the top surface 21 is provided by any suitable printing process, preferably a color printing process to support color graphical images 32. A plurality of such devices 10 may be stacked together, such a stack being mutually held together by the adhesive 25 on the back of each device 10, much like common sticky notes (i.e., Post-it® notes), the top device 10 being peeled off of the stack for use. After single patient use, each device 10 may then be discarded.

**[0045]** It will be appreciated that, with specific reference to the embodiment device 10, any hospital employee that has passed competencies for correctly filling out the device 10 information (date 52, patient initials 53, body part 56, room/location 54, photographer's signature 57, etc.), correct placement on the subject 100 and correct photographing techniques can then provide the picture 202 for the patient's medical record 200. The data captured in the photo 202 may provide valuable information for the appropriate practitioner to assess, fill out additional documentation, begin appropriate interventions and diagnosis within their scope of practice. It will also be appreciated that reliable, objective facts are consequently made available in the medical record 200 from correct use of the device 10. In turn this may facilitate ease for timely choosing correct treatment and prevention interventions, chart coding and for litigation purposes.

**[0046]** It will be further understood that devices 10 may be adapted for different classification systems. The graphical ranking guide 30 and descriptive ranking guide 40 may thus be changed to conform to such other classification systems, thereby illustrating representative rank classifier indicia for each rank in the classification system, and optionally providing corresponding instructions 51. For example, the graphical ranking guide 30 and descriptive ranking guide 40 could be reconfigured to show images and corresponding text illustrative of the

various ranks in the burn classification system, the Wagner's Scale for foot ulcers, the Payne Martin Classification for skin tears and so forth.

**[0047]** There is an increasing push to move away from paper to all-electronic filing and docketing. This is particularly true in the medical context. To facilitate this, certain embodiments provide a camera that electronically incorporates a virtual rendering of the above-described assessment tool over the photograph being taken, thereby eliminating the need of the actual physical substrate 20.

**[0048]** Cameras that can take pictures and then determine the scale of items displayed in the resultant photograph are known. For example, U.S. patent number 5,969,822 entitled "Arbitrary-Geometry Laser Surface Scanner," discloses a three-dimensional scanning system that may be handheld and records the position of objects. U.S. published application number 2009/0213213, published August 27, 2009, and entitled "Method of Monitoring a Surface Feature and Apparatus Therefore," discloses a device capable of capturing a surface feature and determining a scale associated with the image. Indeed, handheld devices that permit a user to see the scale of the image taken, and electronically measure the area of a region within the image, are on the market, such as the Silhouette Mobile device from ARANZ Medical Limited of New Zealand.

**[0049]** An embodiment device 300 is indicated in Figs. 7 and 8A-8C. Fig. 7 is a functional diagram of the device 300, while Figs. 8A-8C show back views of the device 300 with image manipulation being performed by a user according to an embodiment assessment method. The device 300 uses known image capturing and scale determination technology to capture an image and then introduce into that image a virtual representation of the assessment tool 10 discussed above at a scale that is consistent with the determined scale of the image. The device 300 includes an image capturing unit 310, a scale determination unit 320, memory 330, an input/output (I/O) interface 340 and a central processing unit (CPU) 350.

**[0050]** The image capturing unit 310 includes all the components needed to capture an image and store a digital representation of the image 334 in the memory 330; such components may include, for example, a light capturing device, such as a CCD or the like; an optical focusing unit including lenses, a lens driving motor, and the like. Any suitable image capturing unit 310 may be used.

**[0051]** The scale determination unit 320 determines the scale 335 of the image 334 captured by the image capturing system 310. The scale determination unit 320 may include, for example, one or more lasers to create a pre-determined pattern within the view of the image capturing unit 310, optional sensors to determine the tilt of the device 300, and so forth, and may also include software 338 within the memory 330 that is program code executable by the CPU 350 to process collected data and apply an algorithm to obtain the scale 335, which is

then stored in the memory 330. Any suitable scale determination system 320 may be used.

**[0052]** The memory 330 may include both volatile and non-volatile memory and is used to store data and software 338 executable by the CPU 350 to provide the functionality of the device 300 as described above and in the following. For example, as indicated the software 338 may include algorithms to obtain the captured image scale 335. The software 338 may also include program code to control the I/O 340 to support a suitable user interface for the device 300. Finally, the software 338 may include code to generate an assessment image 336 that includes a virtual representation of an embodiment assessment tool superimposed onto the image 334 captured by the image capturing unit 310 and at a scale or size that is conformal to the scale 335 of the captured image 336. To this end the memory 330 further includes data 332 representative of an embodiment assessment tool. For example, this may be an actual image 332 of an embodiment assessment tool, such as the device 10, or may be data that is processed by the CPU 350 to generate such an image. This assessment tool image data 332 further includes a scale 333 that indicates the scale of the assessment image data 332.

**[0053]** The I/O 340 may include buttons 342, a display 346 (which may be touch sensitive), a speaker, plugs, data ports 348 (i.e., USB, FireWire, Bluetooth, etc.) and the like to support a user interface and the exchange of data with other devices, as known in the art.

**[0054]** The CPU 350 is in communications with the I/O 340, the memory 330, the scale determination unit 320 and the image capturing unit 310 and executes software 338 to support and control the various units 310-340, to provide a user interface and to provide the overall functionality of the device 300. Any suitable software 338 may be employed to provide the functionality as described herein, and coding such software 338 should be well within the means of one having ordinary skill in the art after having the benefits of this disclosure.

**[0055]** Upon receipt of a signal via the I/O interface 340 to take a picture, the CPU 350 directs the image capturing unit 310 and the scale determination unit 320 to respectively take a photograph and to determine the scale of the resultant image 334. The image 334 and its scale 335 are then stored in the memory 330. The image 334 may be presented on the display 346, as shown in Fig. 8A. Then, such as in response to a user request via the I/O interface 340, the CPU 350 compares the scale 335 of the image 334 to the scale 333 of the virtual assessment tool 332 and performs linear scaling of the assessment tool image data 332 to generate a conformal assessment tool image 337 that is at a scale that equals or substantially equals (i.e., within display tolerances or user viewing tolerances) the scale 335 of the captured image 334. Any suitable image processing algorithm may then be employed by the CPU 350 to superimpose the conformal assessment tool image 337 onto the captured image 334 to thereby generate the assessment image

336. The assessment image 336 may be presented on the display 346, as shown in Fig. 8B, in which the assessment tool image 337 is initially presented in a pre-determined location relative to the captured image 334, such as in the upper right hand corner of the captured image 334.

**[0056]** As indicated in Fig. 8C, in preferred embodiments the user interface 342, 346 may permit the user to move the conformal image 337 around the captured image 334, using any suitable image manipulation techniques and user interfaces, to determine the final positioning of the virtual assessment tool image 337 with respect to the captured image 334; once the user is satisfied with the final position, indicated for example via a suitable signal with the I/O 340, the CPU 350 generates the final assessment image 336 with the conformal assessment tool 337 positioned thereon as desired by the user. This assessment image 336 may finally replace the originally captured image 334, or may be stored in the memory 330 together with the captured image 334.

**[0057]** It will be appreciated that in some embodiments the device 300 may permit the user to enter alpha-numeric data via the I/O interface 340, which can then be used to fill in forms or fields in the virtual assessment tool image 337. Hence, data entered by the user into the device 300 may appear within the assessment tool image 337 on the final assessment image 336. This final assessment image 336 may then be downloaded into another device via the data port 348 for printing, insertion into an electronic file or the like.

**[0058]** All publications cited in the specification, both patent publications and non-patent publications, are indicative of the level of skill of those skilled in the art to which this invention pertains.

**[0059]** Although the invention herein has been described with reference to particular embodiments, it is to be understood that these embodiments are merely illustrative of the principles and applications of the present invention. It is therefore to be understood that numerous modifications may be made to the illustrative embodiments and that other arrangements may be devised without departing from the scope of the present invention as defined by the following claims.

## Claims

1. A diagnostic tool for classifying a patient's affliction (102), the tool (10) comprising a first arm (12) and a second arm (14) joined in an L-shaped configuration, a top surface (21) of the first arm (12) comprising a graphical ranking guide (30) comprising a plurality of images (32) that graphically illustrate at least a portion of rank classifier indicia for a classification system comprising a plurality of ranks, each of the images (32) corresponding to at least one of the ranks.

2. The diagnostic tool of claim 1 wherein each of the ranks has at least one corresponding image (32).

3. The diagnostic tool of claim 1 wherein the images (32) are color images.

4. The diagnostic tool of claim 3 wherein the color images (32) are color photographs of afflictions (102) in states corresponding to the ranks in the classification system.

5. The diagnostic tool of claim 1 wherein a top surface (21) of the second arm (14) comprises a descriptive ranking guide (40) comprising a plurality of rank descriptors (42) containing text describing at least a portion of the rank classifier indicia, each of the rank descriptors (42) corresponding to at least one of the ranks.

6. The diagnostic tool of claim 5 wherein a bottom surface (29) of the first arm (12) or the second arm (14) comprises an adhesive (25).

7. The diagnostic tool of claim 5 wherein the first arm (12) further comprises a first ruler (12) and the second arm (14) further comprises a second ruler (24), and wherein origins of the first ruler (22) and the second ruler (24) are co-aligned.

8. The diagnostic tool of claim 1 wherein the first arm (12) and the second arm (14) are formed from a paper substrate (20).

9. The diagnostic tool of claim 1 further comprising an antimicrobial or antiseptic agent.

10. The diagnostic tool of claim 8 wherein the top surface (21) of the first arm (12) or the second arm (14) comprises one or more fields configured for the entry of information.

11. A diagnostic method comprising:

obtaining an L-shaped diagnostic tool (10) comprising a first arm (12) and a second arm (14), the first arm (12) or the second arm (14) comprising one or more of a graphical ranking guide (30) and a descriptive ranking guide (40) configured in accordance with a classification system, the first arm (12) and the second arm (14) respectively comprising a first ruler (22) and a second ruler (24);  
disposing the L-shaped diagnostic tool (10) adjacent to an affliction (102);  
taking a picture (202) comprising the affliction (102) and at least a portion of the L-shaped diagnostic tool (10); and  
utilizing the one or more of the graphical ranking

- guide (30) and the descriptive ranking guide (40) in the picture to determine a rank of the affliction (102) within the classification system.
12. The diagnostic method of claim 11 further comprising making a print of the picture (202) and coupling the print to a form (200).
13. The diagnostic method of claim 11 further comprising utilizing the first ruler (22) and the second ruler (24) to estimate one or more of the area of the affliction (102), extent of the affliction (102) along the first arm (12), and extent of the affliction (102) along the second arm (14).
14. A diagnostic imaging tool (300) with a diagnostic tool (10) according to one of claims 1 to 10 and further comprising:
- an image capturing unit (310);
  - a scale determination unit (320);
  - a central processing unit (350); and
  - memory (330) for storing data and program code, the data including assessment tool image data (332), the program code executable by the central processing unit (350) to perform the following steps:
    - causing the image capturing unit (310) to capture an image and store the image in the memory as a captured image (334);
    - causing the scale determination unit (320) to determine a scale (335) associated with the captured image (334);
    - generating a conformal assessment tool image (337) having a scale that is substantially equal to the scale (335) of the captured image (334); and
    - generating an assessment image (336) that comprises at least a portion of the assessment tool image (337) and at least a portion of the captured image (334);
    - wherein the assessment tool image (337) comprises an image of said diagnostic tool (10) according to one of claims 1 to 10.
15. The diagnostic imaging tool of claim 14 further comprising an input/output interface (340), wherein the program code further causes the central processing unit (350) to position the assessment tool image (337) within the assessment image (336) according to instructions received from the input/output interface (340).

## Patentansprüche

1. Diagnosewerkzeug zur Klassifizierung einer Krankheit (102) eines Patienten, wobei das Werkzeug (10) einen ersten Arm (12) und einen zweiten Arm (14) aufweist, welche zu einer L-förmigen Anordnung verbunden sind, wobei eine Oberseite (21) des ersten Arms (12) eine grafische Einstufungsführung (30) aufweist, welche eine Mehrzahl von Bildern (32), die zumindest einen Teil von Einstufungsklassiererindizes für ein Klassierungssystem, welches eine Mehrzahl von Stufen aufweist, illustrieren, wobei jedes der Bilder (32) zumindest einer der Stufen entspricht.
2. Diagnosewerkzeug nach Anspruch 1, wobei jede der Stufen zumindest ein entsprechendes Bild (32) aufweist.
3. Diagnosewerkzeug nach Anspruch 1, wobei die Bilder (32) Farbbilder sind.
4. Diagnosewerkzeug nach Anspruch 3, wobei die Farbbilder (32) farbige Fotografien von Krankheiten (102) in Stadien, die den Stufen in dem Klassierungssystem entsprechen, sind.
5. Diagnosewerkzeug nach Anspruch 1, wobei eine Oberseite (21) des zweiten Arms (14) einen beschreibenden Einführungsführung (40) aufweist, welcher eine Mehrzahl von Stufendescriptoren (42) aufweist, welche Text aufweisen, der zumindest einen Teil der Einstufungsklassiererindizes beschreibt, wobei jeder der Stufendescriptoren (42) zumindest einer der Stufen entspricht.
6. Diagnosewerkzeug nach Anspruch 5, wobei eine Bodenfläche (29) des ersten Arms (12) oder des zweiten Arms (14) ein Klebemittel (25) aufweist.
7. Diagnosewerkzeug nach Anspruch 5, wobei der erste Arm (12) weiterhin ein erstes Lineal (22) und der zweite Arm (14) weiterhin ein zweites Lineal (24) aufweist, und wobei die Ursprünge des ersten Lineals (22) und des zweiten Lineals (24) aufeinander abgestimmt sind.
8. Diagnosewerkzeug nach Anspruch 1, wobei der erste Arm (12) und der zweite Arm (14) von einem Papiersubstrat (20) gebildet werden.
9. Diagnosewerkzeug nach Anspruch 1, welches weiterhin ein antimikrobielles Mittel oder antiseptisches Mittel aufweist.
10. Diagnosewerkzeug nach Anspruch 8, wobei die Oberseite (21) des ersten Arms (12) oder des zweiten Arms (14) eines oder mehrere Felder, die für den

Eintritt von Information ausgebildet sind, aufweist.

**11. Diagnoseverfahren, aufweisend:**

Bereitstellen eines L-förmigen Diagnosewerkzeugs (10), welches einen ersten Arm (12) und einen zweiten Arm (14) aufweist, wobei der erste Arm (12) oder der zweite Arm (14) eine oder mehrere grafische Einstufungsführungen (30) und eine beschreibende Einstufungsführung (40) aufweist, die gemäß einem Klassierungssystem ausgestaltet ist, wobei der erste Arm (12) bzw. der zweite Arm (14) ein erstes Lineal (22) und ein zweites Lineal (24) aufweisen, Anordnen des L-förmigen Diagnosewerkzeugs (10) angrenzend an eine Krankheit (102), Aufnehmen eines Bildes (202), welches die Krankheit (102) und zumindest einen Teil des L-förmigen Diagnosewerkzeugs (10) enthält, und Verwenden der einen oder mehrerer der grafischen Einstufungsführungen (30) und der beschreibenden Einstufungsführung (40) in dem Bild, um eine Stufe der Krankheit (102) innerhalb des Klassierungssystems zu bestimmen.

**12. Diagnoseverfahren nach Anspruch 11, weiterhin aufweisend Anfertigen eines Drucks des Bildes (202) und Koppeln des Drucks an ein Formular (200).**

**13. Diagnoseverfahren nach Anspruch 11, weiterhin mit Verwenden des ersten Lineals (22) und des zweiten Lineals (24), um ein Gebiet oder mehrere Gebiete der Krankheit (102), den Umfang der Krankheit (102) entlang des ersten Arms (12) und den Umfang der Krankheit (102) entlang des zweiten Arms (14) abzuschätzen.**

**14. Diagnosebildwerkzeug (300) mit einem Diagnosewerkzeug (10) nach einem der Ansprüche 1 bis 10 und weiterhin aufweisend:**

eine Bilderfassungseinheit (310), eine Größenbestimmungseinheit (320), eine zentrale Verarbeitungseinheit (350), und einen Speicher (330) zum Speichern von Daten und Programmcode, wobei die Daten Bewertungswerkzeugbilddateien (332) einschließen, wobei der Programmcode durch die zentrale Verarbeitungseinheit (350) ausführbar ist, um die folgenden Schritte auszuführen:

Veranlassen der Bilderfassungseinheit (310), ein Bild zu erfassen und das Bild in dem Speicher als ein erfasstes Bild (334) zu speichern,

Veranlassen der Größenbestimmungseinheit (320), eine Größe (335) in Verbindung mit dem erfassten Bild (334) zu bestimmen, Erzeugen eines konformen Bewertungswerkzeugbildes (337), welches eine Größe hat, die im Wesentlichen gleich der Größe (335) des erfassten Bildes (334) ist, und Erzeugen eines Bewertungsbildes (336), welches zumindest einen Teil des Bewertungswerkzeugbildes (337) und zumindest einen Teil des erfassten Bildes (334) aufweist, wobei das Bewertungswerkzeugbild (337) ein Bild des Diagnosewerkzeugs (10) nach einem der Ansprüche 1 bis 10 aufweist.

**15. Diagnosebildwerkzeug nach Anspruch 14, welches weiterhin eine Eingangs-/Ausgangsschnittstelle (340) aufweist, wobei der Programmcode weiterhin die zentrale Verarbeitungseinheit (350) dazu veranlasst, das Bewertungswerkzeugbild (337) innerhalb des Bewertungsbildes (336) gemäß den von der Eingangs-/Ausgangsschnittstelle (340) erhaltenen Instruktionen zu positionieren.**

**Revendications**

**1.** Outil de diagnostic pour classifier une plaie d'un patient (102), l'outil (10) comprenant un premier bras (12) et un deuxième bras (14) joints en une configuration en L, une surface supérieure (21) du premier bras (12) comprenant un guide de classement graphique (30) comprenant une pluralité d'images (32) qui illustrent graphiquement au moins une partie de repères de classement de rang pour un système de classification comprenant une pluralité de rangs, chacune des images (32) correspondant à au moins l'un des rangs.

**2.** Outil de diagnostic selon la revendication 1, dans lequel chacun des rangs a au moins une image (32) correspondante.

**3.** Outil de diagnostic selon la revendication 1, dans lequel les images (32) sont des images en couleur.

**4.** Outil de diagnostic selon la revendication 3, dans lequel les images en couleur (32) sont des photographies en couleur de plaies (102) dans des états correspondant aux rangs dans le système de classification.

**5.** Outil de diagnostic selon la revendication 1, dans lequel une surface supérieure (21) du deuxième bras (14) comprend un guide de classement descriptif (40) comprenant une pluralité de descripteurs de

- rang (42) contenant un texte décrivant au moins une partie des repères de classement de rang, chacun des descripteurs de rang (42) correspondant à au moins l'un des rangs.
6. Outil de diagnostic selon la revendication 5, dans lequel une surface inférieure (29) du premier bras (12) ou du deuxième bras (14) comprend un adhésif (25).
7. Outil de diagnostic selon la revendication 5, dans lequel le premier bras (12) comprend en outre une première règle (12) et le deuxième bras (14) comprend en outre une deuxième règle (24), et dans lequel les origines de la première règle (22) et de la deuxième règle (24) sont coalignées.
8. Outil de diagnostic selon la revendication 1, dans lequel le premier bras (12) et le deuxième bras (14) sont formés à partir d'un substrat en papier (20).
9. Outil de diagnostic selon la revendication 1, comprenant en outre un agent antimicrobien ou antiseptique.
10. Outil de diagnostic selon la revendication 8, dans lequel la surface supérieure (21) du premier bras (12) ou du deuxième bras (14) comprend un ou plusieurs champs configurés pour l'entrée d'informations.
11. Procédé de diagnostic, comprenant :
- l'obtention d'un outil de diagnostic en forme de L (10) comprenant un premier bras (12) et un deuxième bras (14), le premier bras (12) ou le deuxième bras (14) comprenant un ou plusieurs parmi un guide de classement graphique (30) et un guide de classement descriptif (40) configurés conformément à un système de classification, le premier bras (12) et le deuxième bras (14) comprenant respectivement une première règle (22) et une deuxième règle (24) ;  
l'agencement de l'outil de diagnostic en forme de L (10) adjacent à une plaie (102) ;  
la prise d'une image (202) comprenant la plaie (102) et au moins une partie de l'outil de diagnostic en forme de L (10) ; et  
l'utilisation d'un ou plusieurs parmi le guide de classement graphique (30) et le guide de classement descriptif (40) dans l'image pour déterminer un rang de la plaie (102) dans le système de classification.
12. Procédé de diagnostic selon la revendication 11, comprenant en outre l'exécution d'une impression de l'image (202) et l'association de l'impression à un formulaire (200).
13. Procédé de diagnostic selon la revendication 11, comprenant en outre l'utilisation de la première règle (22) et de la deuxième règle (24) pour évaluer une ou plusieurs parmi la surface de la plaie (102), l'étendue de la plaie (102) le long du premier bras (12), et l'étendue de la plaie (102) le long du deuxième bras (14).
14. Outil de formation d'image de diagnostic (300) avec un outil de diagnostic (10) selon l'une des revendications 1 à 10, et comprenant en outre :
- une unité de capture d'image (310) ;  
une unité de détermination d'échelle (320) ;  
une unité de traitement centrale (350) ; et  
une mémoire (330) pour mémoriser des données et un code de programme, les données comprenant des données d'image d'outil d'évaluation (332), le code de programme pouvant être exécuté par l'unité de traitement centrale (350) pour effectuer les étapes suivantes consistant à :
- amener l'unité de capture d'image (310) à capturer une image et à mémoriser l'image dans la mémoire en tant qu'image capturée (334) ;  
amener l'unité de détermination d'échelle (320) à déterminer une échelle (335) associée à l'image capturée (334) ;  
générer une image d'outil d'évaluation conforme (337) ayant une échelle qui est sensiblement identique à l'échelle (335) de l'image capturée (334) ; et  
générer une image d'évaluation (336) qui comprend au moins une partie de l'image d'outil d'évaluation (337) et au moins une partie de l'image capturée (334) ;  
dans lequel l'image d'outil d'évaluation (337) comprend une image dudit outil de diagnostic (10) selon l'une des revendications 1 à 10.
15. Outil de formation d'image de diagnostic selon la revendication 14, comprenant en outre une interface d'entrée/sortie (340), dans lequel le code de programme amène en outre l'unité de traitement centrale (350) à positionner l'image d'outil d'évaluation (337) dans l'image d'évaluation (336) conformément à des instructions reçues de l'interface d'entrée/sortie (340).

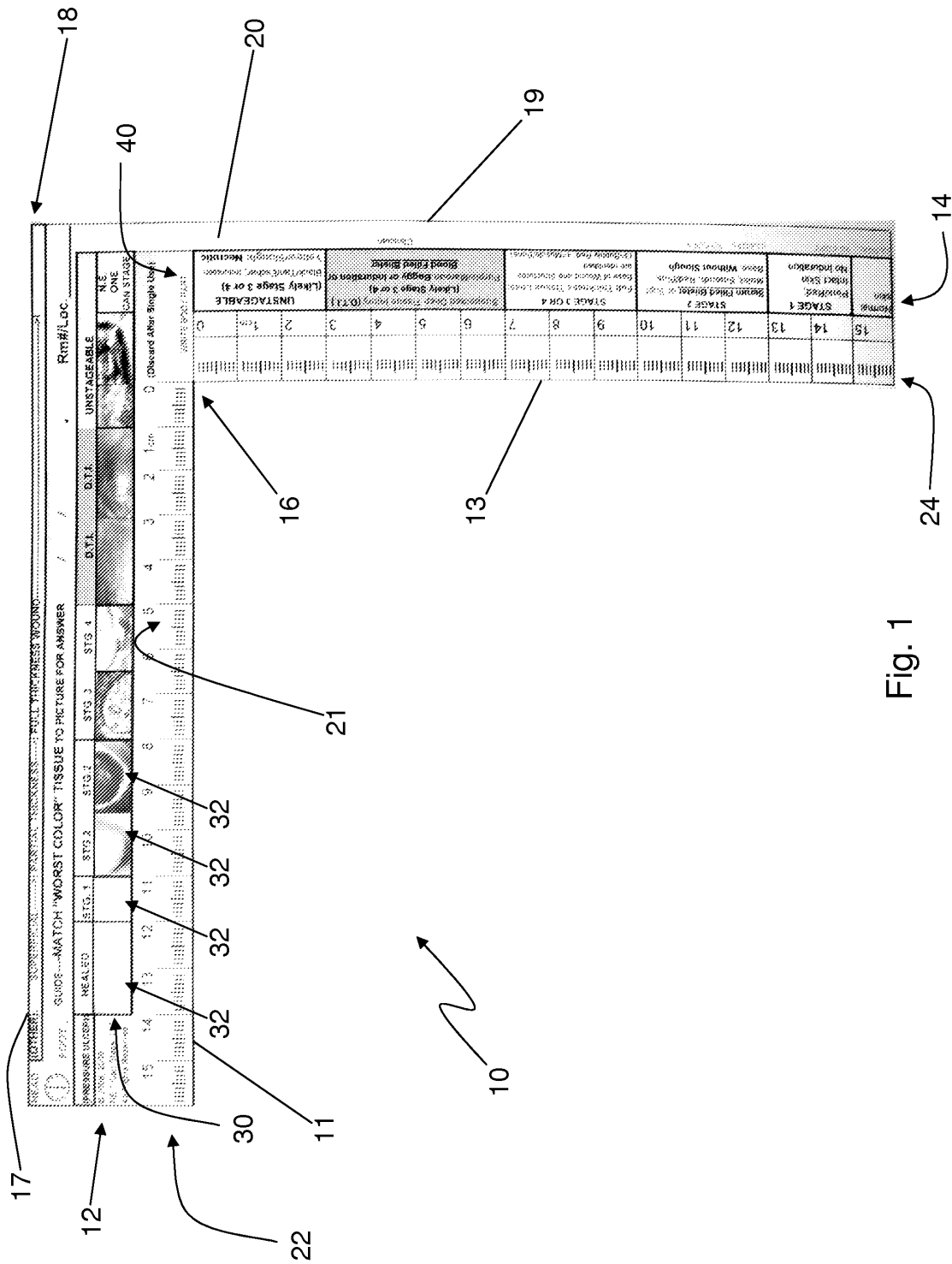

Fig. 1



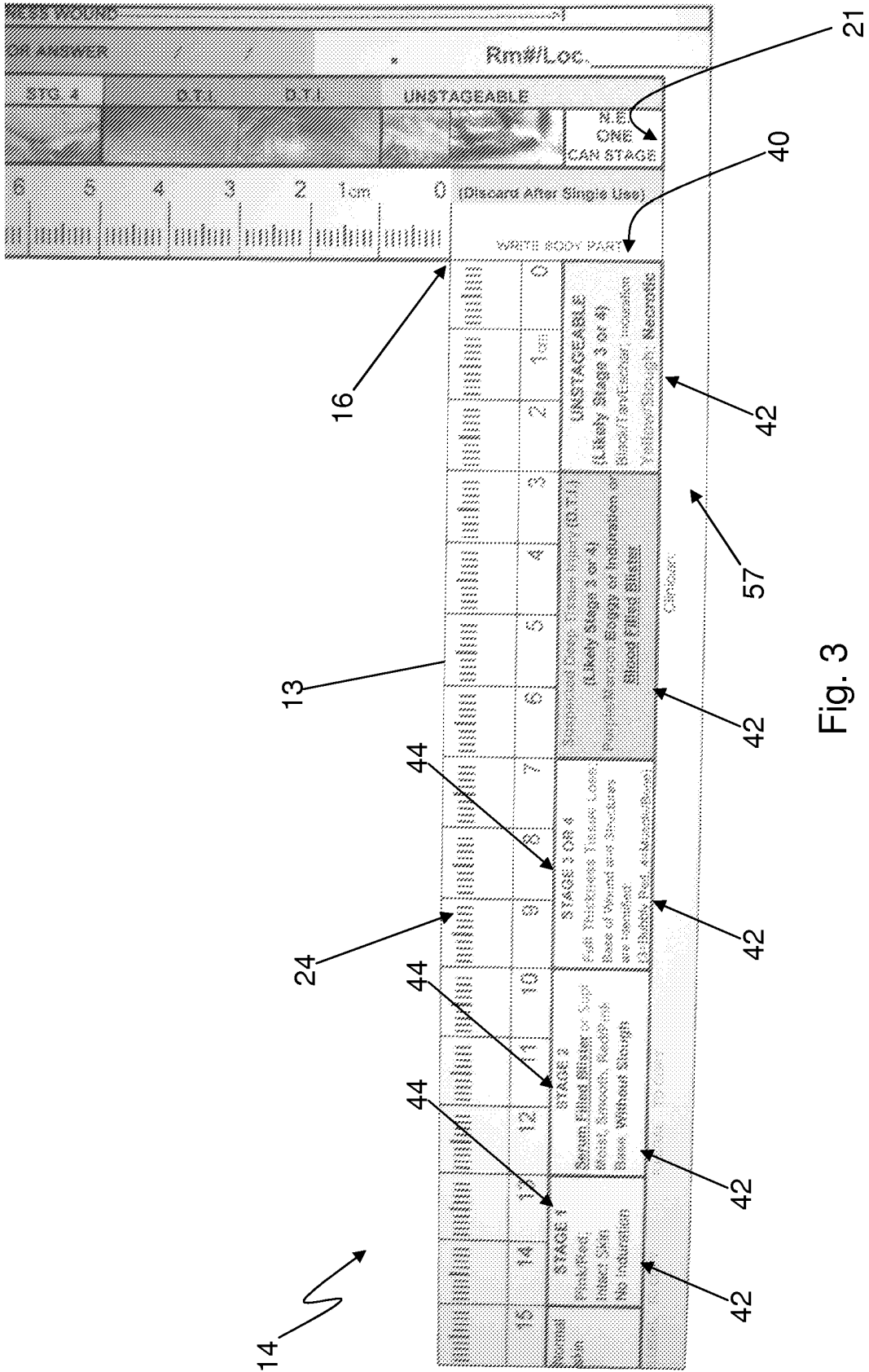

Fig. 3

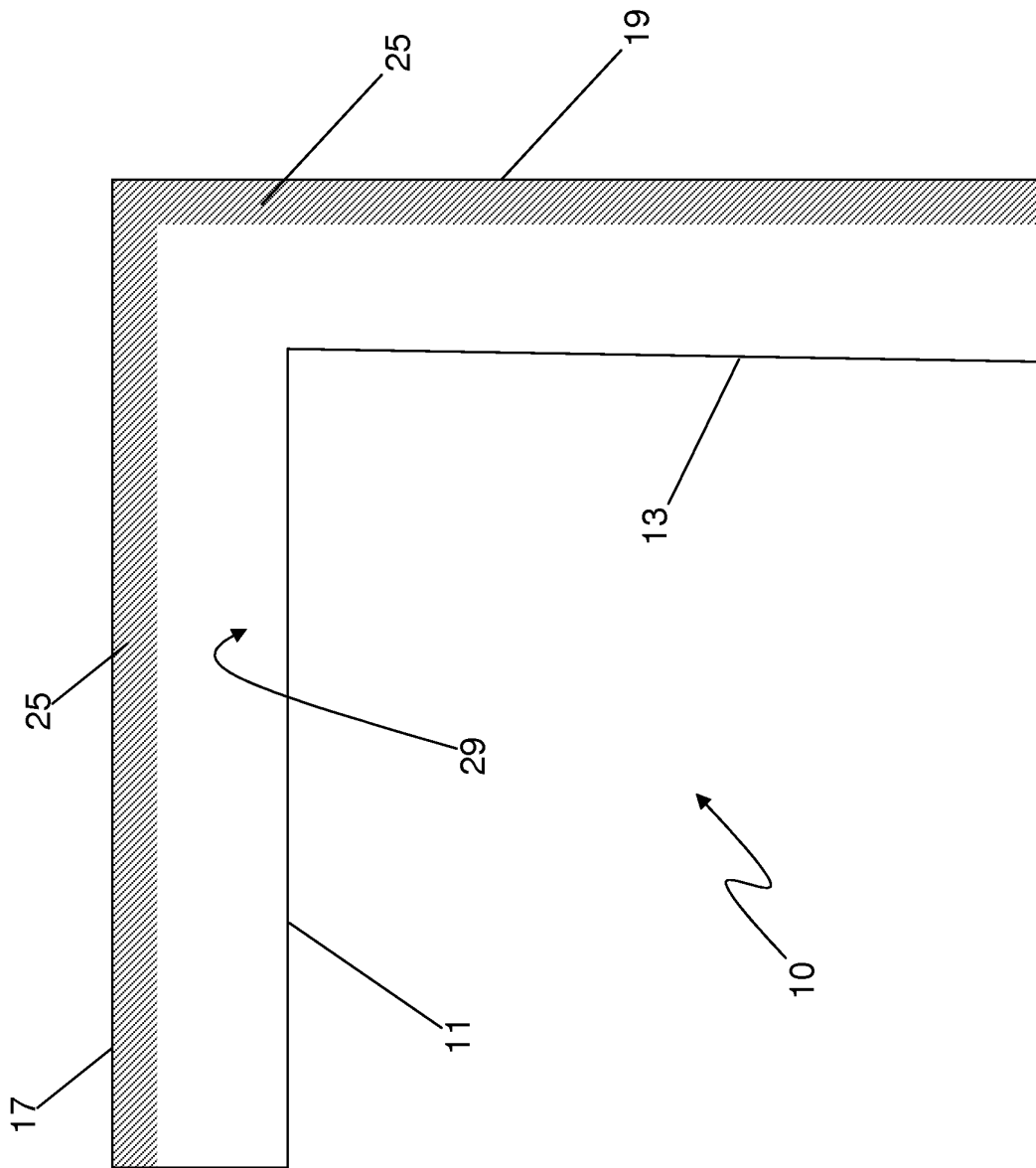

Fig. 4



**PHOTOGRAPHIC WOUND DOCUMENTATION**

PHYSICIAN SIGNATURE: \_\_\_\_\_ DATE: \_\_\_\_\_ TIME: \_\_\_\_\_

PHYSICAL THERAPIST NURSE SIGNATURE: *Christy Williams* DATE: 10/27/09 TIME: 05:00

202

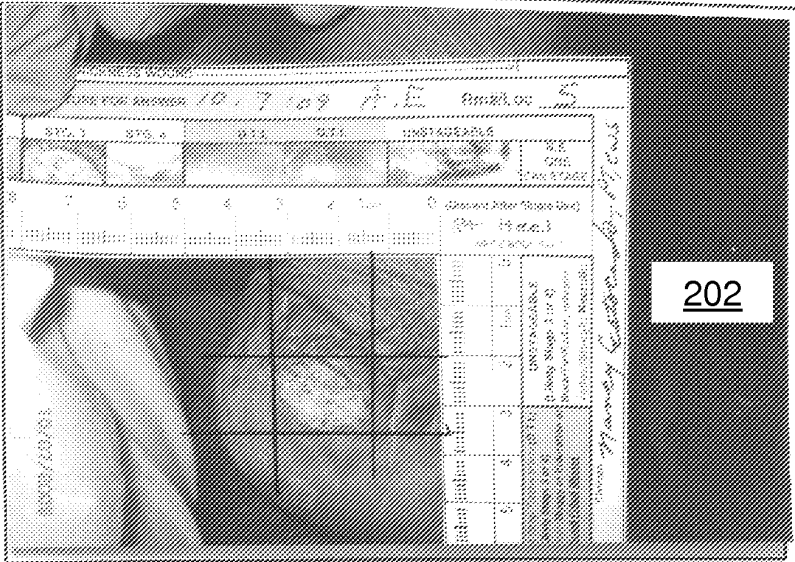

LOCATION (ANATOMICAL SITE): Rt. Head Ear

"Present on Admission"  Yes  No  Opaque (intact serum filled blister)  Exposed Muscle/Tendon/Bone

"WOUND BED" (Tissue Type)  Normal for skin or healed  Red/Anus/Smooth/Superficial  Purple/Maroon/Deep Hue of Red (in blood filled blister)  Red/Pink (intact skin)  Red/Moist/Bubbly (granulation)  Black/Brown/Escara

Pink (epithelial)  Yellow (slough)

\* Worst Tissue Type/Color is: Black/Brown and % 80%

WOUND TYPE:  Healed  Stage III  Deep Tissue Injury (likely III or IV)  Pressure Ulcer (OR)  Stage I  Stage IV  Unstageable (likely III or IV)  Stage II

Other  Superficial  Partial Thickness  Full Thickness

DETAILS: \* Size (cm) (LxW) 1.5 x 2.0 Depth (cm) 0.5

Tunnelling (cm): \_\_\_\_\_ Undermining (cm): \_\_\_\_\_

EXUDATE: Color  None  Slight  Moderate  Foul

Type  None  Serous  Serosanguinous  Bloody  Pusulent

\* Amount  None  Small  Moderate  Large

WOUND EDGES/SURROUNDING TISSUE:  Normal for skin  Peripheral tissue edema  Maceration  Hardness/induration palpated  Rolled edges  Other: \_\_\_\_\_

Comments: *Wound on right side of head, approx. 1.5 x 2.0 cm. Depth approx. 0.5 cm. Wound bed is black/brown/eschar. Wound edges are well defined. No tunneling or undermining.*

PHYSICIAN SIGNATURE: \_\_\_\_\_ DATE: \_\_\_\_\_ TIME: \_\_\_\_\_

Page: 1 of 2

200

Fig. 6

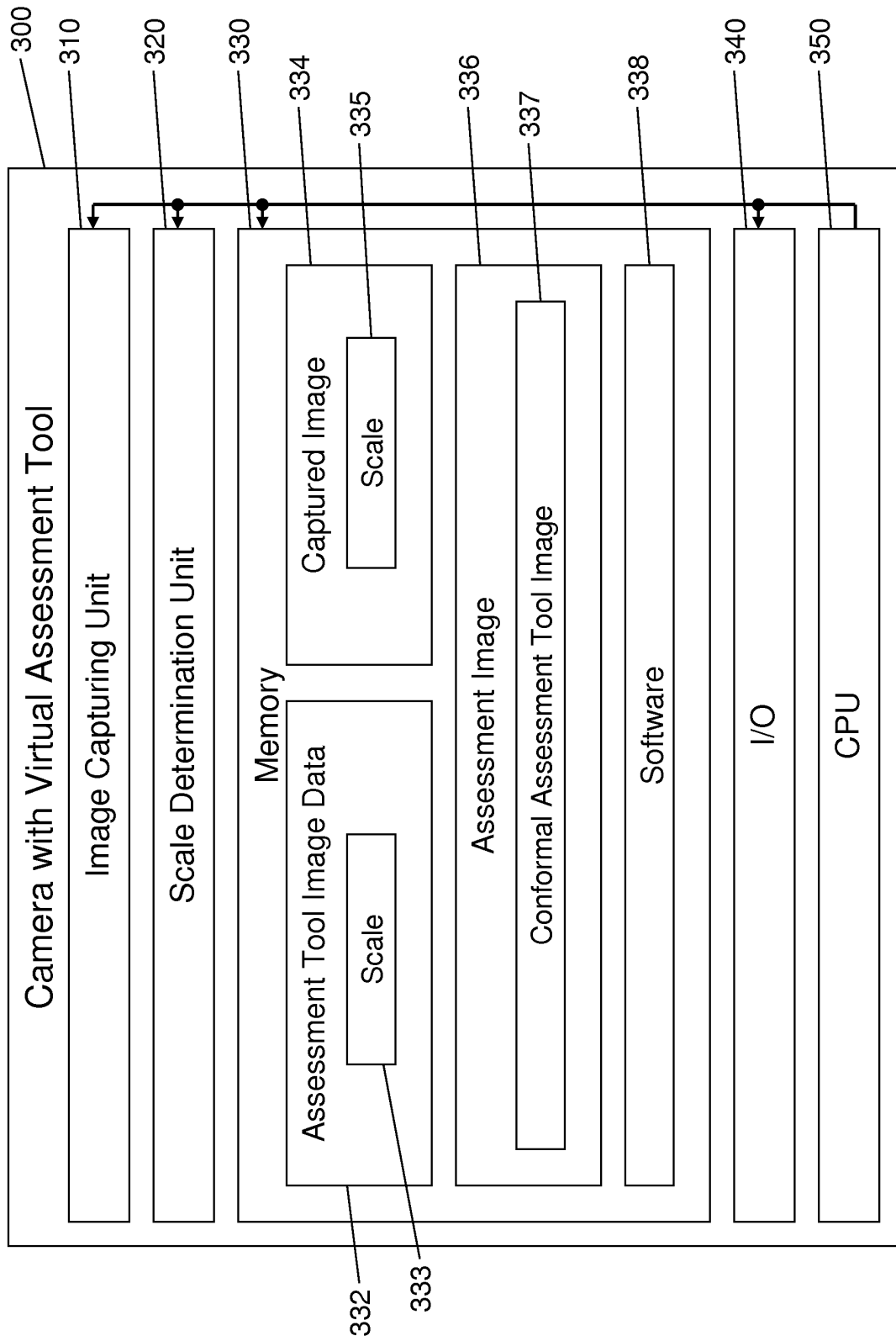

Fig. 7

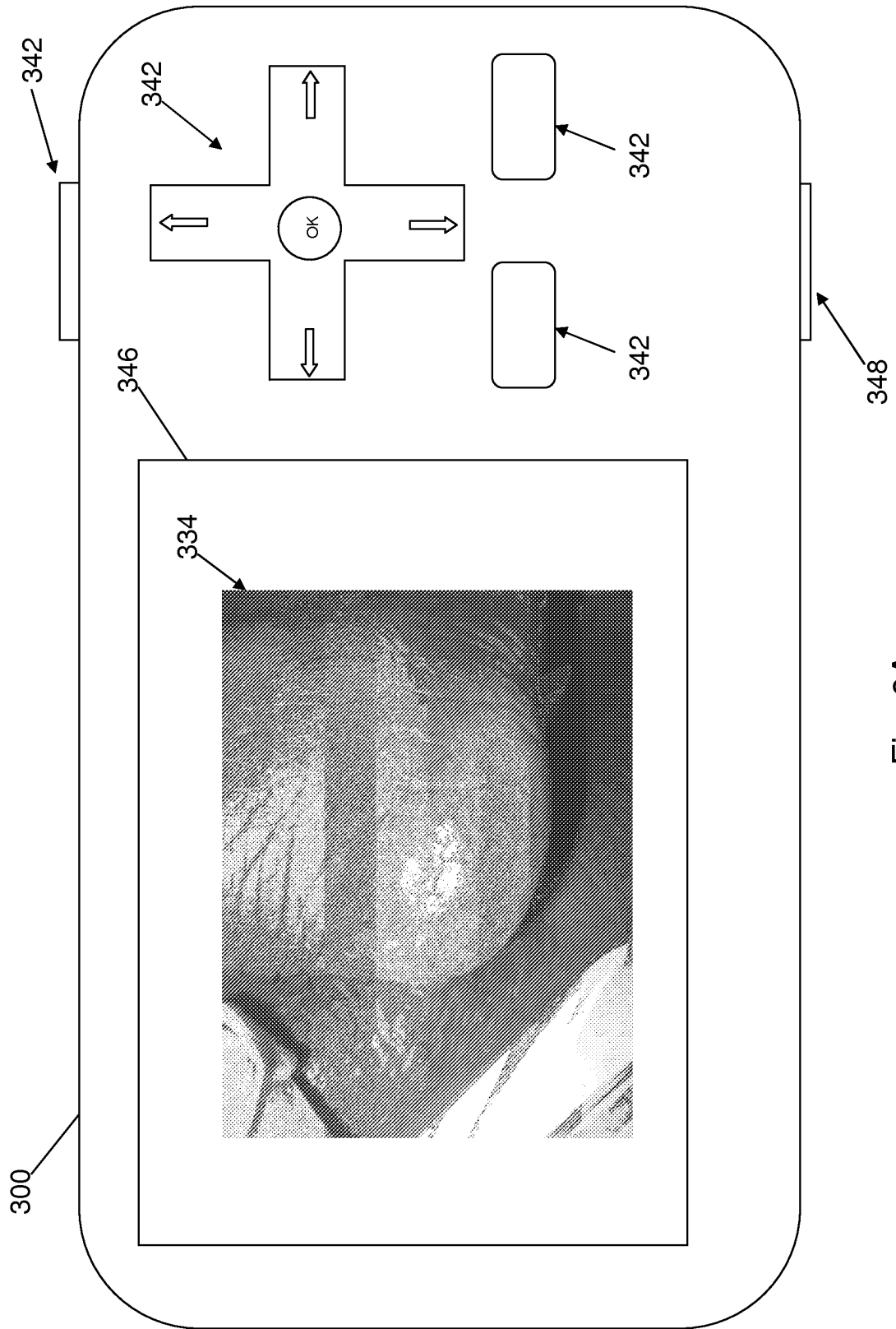

Fig. 8A

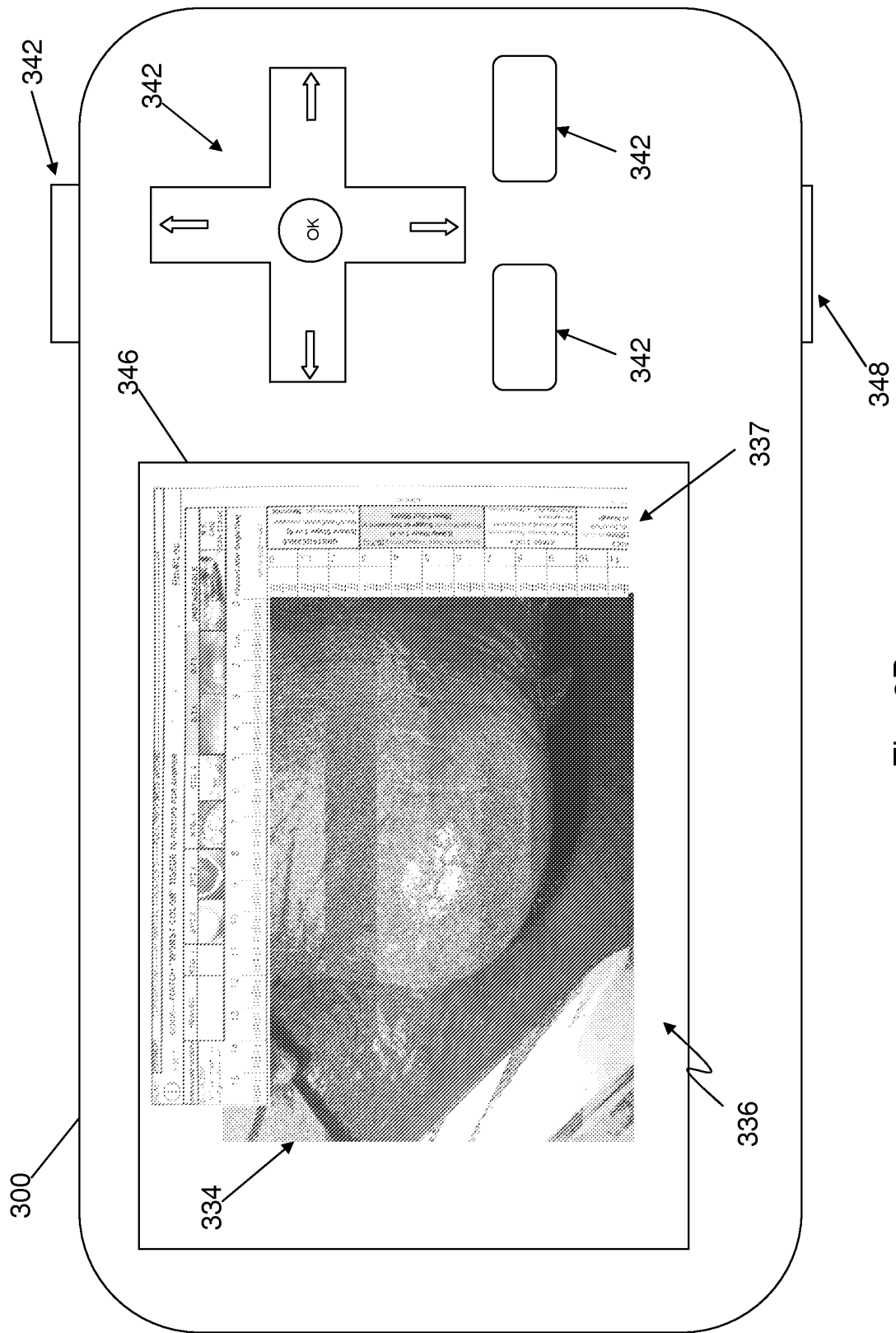

Fig. 8B

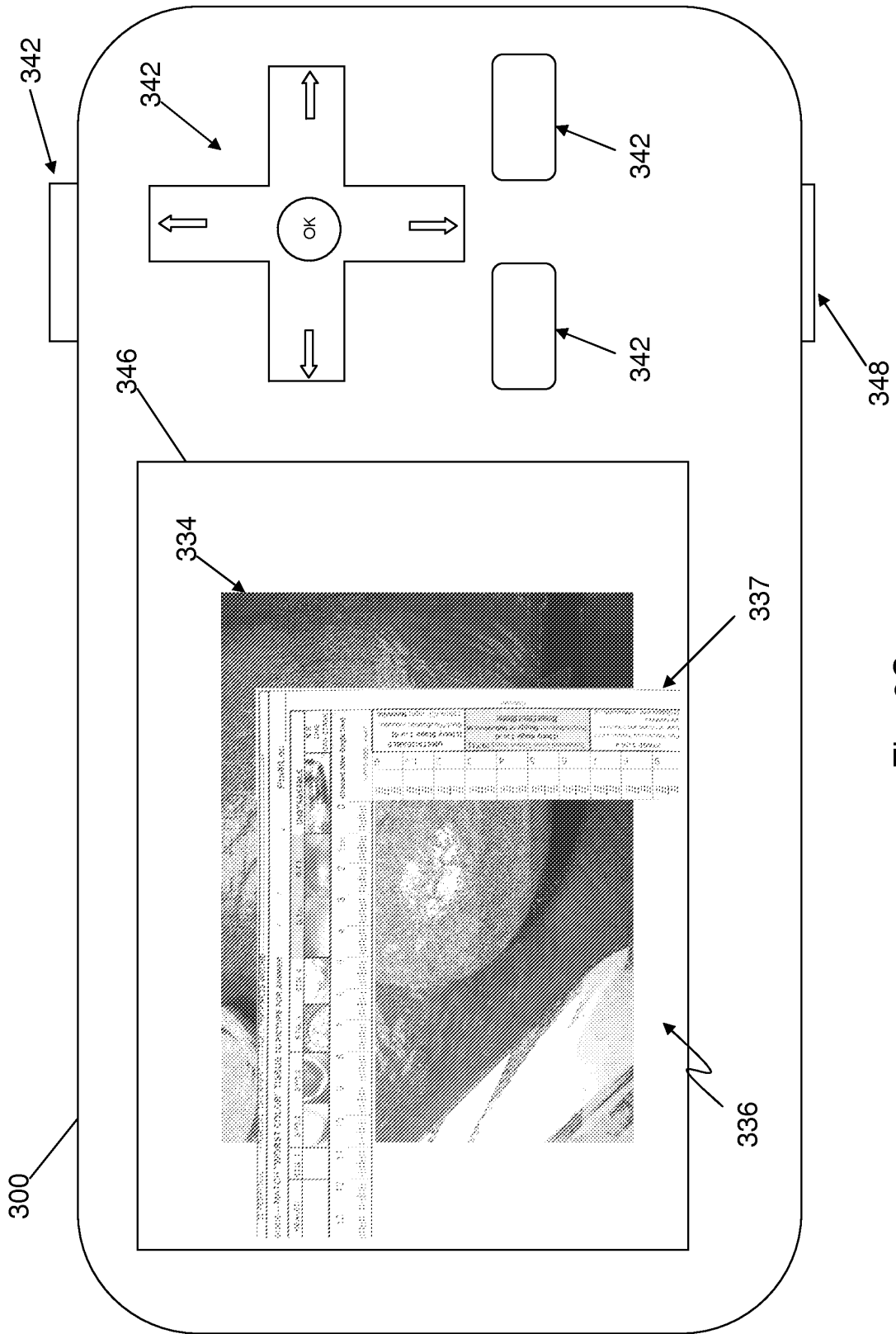

Fig. 8C

**REFERENCES CITED IN THE DESCRIPTION**

*This list of references cited by the applicant is for the reader's convenience only. It does not form part of the European patent document. Even though great care has been taken in compiling the references, errors or omissions cannot be excluded and the EPO disclaims all liability in this regard.*

**Patent documents cited in the description**

- US 4483075 A [0007]
- US 5969822 A [0048]
- US 20090213213 A [0048]

**Non-patent literature cited in the description**

- **L. RUSSELL.** The importance of wound documentation and classification. *British Journal of Nursing, Allen, London, GB*, 01 January 1999, vol. 8 (20), 1342-1054 [0005]
- **A. M. FETTE.** *A clinimetric analysis of wound measurement tools*, 31 January 2006 [0006]

专利名称(译)	皮肤和伤口评估工具		
公开(公告)号	<a href="#">EP2493371B1</a>	公开(公告)日	2015-08-26
申请号	EP2010828796	申请日	2010-10-21
[标]申请(专利权)人(译)	ESTOCADO NANCY ANN		
申请(专利权)人(译)	ESTOCADO , NANCY ANN		
当前申请(专利权)人(译)	ESTOCADO , NANCY ANN		
[标]发明人	ESTOCADO NANCY ANN		
发明人	ESTOCADO, NANCY ANN		
IPC分类号	A61B5/00		
CPC分类号	A61B5/1072 A61B5/444 A61B5/445 A61B5/7264 G01B3/04 G16H50/20		
优先权	12/606773 2009-10-27 US		
其他公开文献	EP2493371A2 EP2493371A4		
外部链接	<a href="#">Espacenet</a>		

摘要(译)

L形诊断工具优选地由具有背衬的纸制成，所述背衬具有接触粘合剂。每个臂都有一个尺子，其原点在臂的交叉处的内角处共同对齐。一只手具有分类系统内各种等级中的每一个的痛苦的代表性彩色图像。另一只手包含每个等级中痛苦的显著特征的文本描述。放置在痛苦周围的L形工具的照片可用于诊断和监测目的。

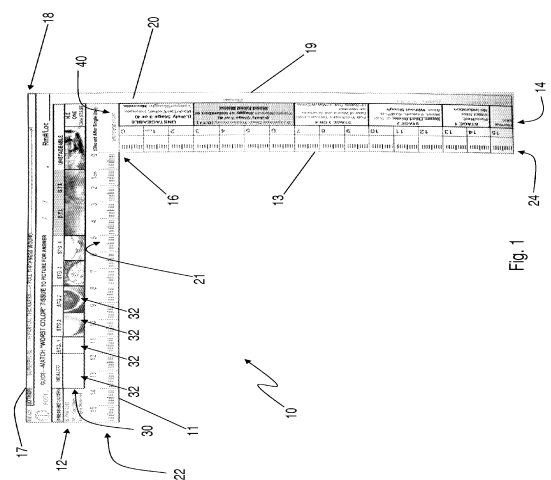

Fig. 1