

(19)



(11)

**EP 2 412 298 B1**

(12)

**EUROPEAN PATENT SPECIFICATION**

(45) Date of publication and mention of the grant of the patent:  
**26.11.2014 Bulletin 2014/48**

(51) Int Cl.:  
**G02B 6/32** <sup>(2006.01)</sup>      **G02B 6/26** <sup>(2006.01)</sup>  
**A61B 5/00** <sup>(2006.01)</sup>      **A61B 1/00** <sup>(2006.01)</sup>  
**A61B 5/02** <sup>(2006.01)</sup>      **G02B 6/255** <sup>(2006.01)</sup>

(21) Application number: **10846992.5**

(86) International application number:  
**PCT/JP2010/053402**

(22) Date of filing: **03.03.2010**

(87) International publication number:  
**WO 2011/108087 (09.09.2011 Gazette 2011/36)**

**(54) LATERALLY EMITTING DEVICE AND METHOD OF MANUFACTURING SAME**

SEITENEMISSIONSVORRICHTUNG UND VERFAHREN ZU IHRER HERSTELLUNG  
DISPOSITIF À ÉMISSION LATÉRALE ET PROCÉDÉ DE FABRICATION ASSOCIÉ

(84) Designated Contracting States:  
**AT BE BG CH CY CZ DE DK EE ES FI FR GB GR HR HU IE IS IT LI LT LU LV MC MK MT NL NO PL PT RO SE SI SK SM TR**

- **FUKUDA Toshiaki**  
Kawasaki-shi  
Kanagawa 210-0863 (JP)

(43) Date of publication of application:  
**01.02.2012 Bulletin 2012/05**

(74) Representative: **Brown, David Leslie**  
Haseltine Lake LLP  
Redcliff Quay  
120 Redcliff Street  
Bristol BS1 6HU (GB)

(73) Proprietor: **Toyo Seikan Group Holdings, Ltd.**  
Shinagawa-ku,  
Tokyo (JP)

(56) References cited:  
**WO-A1-2007/099947**      **WO-A1-2008/081653**  
**WO-A2-01/11409**      **JP-A- 2 077 001**  
**JP-A- 3 279 908**      **JP-A- 2000 509 853**  
**JP-A- 2004 317 437**      **JP-A- 2005 241 822**  
**JP-A- 2007 275 193**      **US-A1- 2008 002 529**  
**US-A1- 2009 190 883**      **US-A1- 2009 262 361**

(72) Inventors:  

- **MARUYAMA Naofumi**  
Kawasaki-shi  
Kanagawa 210-0863 (JP)

**EP 2 412 298 B1**

Note: Within nine months of the publication of the mention of the grant of the European patent in the European Patent Bulletin, any person may give notice to the European Patent Office of opposition to that patent, in accordance with the Implementing Regulations. Notice of opposition shall not be deemed to have been filed until the opposition fee has been paid. (Art. 99(1) European Patent Convention).

**Description**

## Technical Field

**[0001]** The present invention relates to a lateral light emitting device that emits light, which has propagated in an optical fiber, in a lateral direction at an angle related to the optical axis of an optical fiber, and, in particular, is suitable for use as an optical probe for OCT (Optical Coherence Tomography). The present invention also relates to a method of producing the lateral light emitting device.

## Background Art

**[0002]** OCT is a method of creating an optical coherence tomographic image that allows a precise tomographic image of the inside of a subject body to be obtained. OCT uses light reflected back from parts of the subject body in response to low-coherence light laterally emitted from the distal end of an optical probe inserted into an organ of the patient such as a blood vessel or the bowels. A basic technology of the OCT is disclosed in Japanese Examined Patent Application Publication No. 6-35946 (Patent Literature 1), and specific structures of the optical probes are disclosed in Japanese Unexamined Patent Application Publication No. 11-56786 (Patent Literature 2), Japanese Unexamined Patent Application Publication No. 2008-200283 (Patent Literature 3), and so forth.

**[0003]** Fig. 18 is a sectional explanatory view of a related-art lateral light emitting device (optical probe) described in Patent Literatures 2 and 3.

**[0004]** A distal end holding portion 11 is mounted at a distal end of a cylindrical shaft 10, a distal end of an optical fiber 2 that is inserted through the shaft 10 is engaged with a proximal end side of the distal end holding portion 11, and a rod lens 3, to which a prism 4 is bonded, is engaged with a distal end of the distal end holding portion 11. The entirety of the lateral light emitting device is covered with a transparent sheath 12 in order to prevent the subject body from being damaged and prevent the prism 4 and the rod lens 3 from becoming completely detached and being left inside the subject body.

WO 01/11409 describes ultra-small optical probes, including one in which a D-fiber is spliced onto a GRIN/multimode fiber lens and the end polished on a 45 degree angle to reflect the outgoing beam from a single-mode optical fiber through the flat of the D.

US 2009/0262361 describes an optical component for a catheter comprising a spacer, a SELFOC lens and a prism (deflector) at the distal end.

US 2008/0002529 describes an optical head for an optical recording apparatus, comprising a fiber, two GRIN lenses and a prism at the distal end of the optical head.

## Citation List

## Patent Literature

5 **[0005]**

Patent Literature 1: Japanese Examined Patent Application Publication No. 6-35946

10

Patent Literature 2: Japanese Unexamined Patent Application Publication No. 11-56786

Patent Literature 3: Japanese Unexamined Patent Application Publication No. 2008-200283

15

## Summary of Invention

## Problems to be Solved by the Invention

20

**[0006]** In some of the related-art lateral light emitting devices, the rod lens and the prism are bonded to each other with adhesive, and accordingly, have an adhesive layer in an optical path. Thus, there are problems such as variations in quality of a beam, and degradation of quality of a beam due to a gap between the rod lens and prism caused by, for some reason, detachment of the adhesion that bonds the rod lens and the prism together. In the worst case, a problem of the lens becoming completely detached from the prism occurs.

25

30

**[0007]** In addition, since the rod lens 3 and the prism 4 are very small in size, a task to bond these components together is complicated and inefficient. Since the optical fiber and the rod lens need to be engaged with the distal end holding portion 11 at the distal end of the shaft 10 with high precision, skills and time are required in assembly, thereby reducing efficiency in production.

35

**[0008]** Since the shaft 10 and sheath 12 are essential components, the outer diameter needs to be large, thereby causing a problem in that insertion into a very thin blood vessel or the like is impossible.

40

**[0009]** An object of the present invention is to solve the problems of the related-art lateral light emitting device as above and to develop a lateral light emitting device that is free from variations and degradation in beam quality and reduction in reliability, can be easily produced, and has a small diameter in order to be usable for thin blood vessels and the like.

45

## Means for Solving the Problems

50

**[0010]** The present invention is defined in and by the appended claims.

**[0011]** Also described herein is a lateral light emitting device including an optical fiber, a rod lens having a first end fused to an end surface of the optical fiber, and a prism fused to a second end of the rod lens, in which the prism has a basic shape including a planar light emitting surface parallel to an axis formed by cutting part of a

55

circumference of a cylinder, and the prism includes a distal end inclined surface formed by diagonally cutting a distal end portion of the prism, in which light having entered the prism from the optical fiber is reflected by the distal end inclined surface and emitted from the light emitting surface.

**[0012]** The optical fiber and the rod lens, and the rod lens and the prism are joined to each other by fusing. Thus, there is no adhesive layer in an optical path, and accordingly, there are no variations in beam quality, no degradation in beam quality due to detachment of the adhesion, and no complete detachment of the prism. Production can be easily performed using related-art known fiber fusing equipment.

**[0013]** Since the lateral light emitting device needs no shaft or sheath, the outer diameter can be made to be very small. Thus, the lateral light emitting device can be used for a very thin blood vessel and the like.

**[0014]** In most cases, the optical fiber is a single-mode optical fiber. However, the optical fiber may use a polarization maintaining fiber or a multi-mode fiber. In addition, the optical fiber may even use a bundle fiber for image transmission.

**[0015]** The rod lens needs to be formed of silica based glass in order to undergo fusing. The rod lens may use a so-called GI-type fiber, of which the core has a refractive index distribution, or a so-called GRIN lens, of which the entire section has a refractive index distribution.

**[0016]** The rod lens may also use a lens produced by fusing together two types of (or three or more types of) GRIN lenses each having a different numerical aperture as described in Japanese Unexamined Patent Application Publication No. 2005-115097.

**[0017]** The prism needs to be formed of silica based glass in order to undergo fusing. The prism has the basic shape including the planar light emitting surface parallel to the axis formed by cutting part of the circumference of the cylinder (a semi-cylindrical shape). Thus, the prism can be easily produced by drawing (formed into a fiber) a ground base material (a base material produced by grinding part of a circumference of a cylindrical base material) having a sectional shape similar to that of the prism. In addition, the prism in an elongated fiber state can be easily fused to the rod lens.

**[0018]** A typical inclination angle ( $\theta$  in Fig. 3) of the distal end inclined surface of the prism relative to the light emitting surface is  $45^\circ$ . In this case, light is laterally emitted at  $90^\circ$  relative to the axis. By changing the inclined angle ( $\theta$ ) of the distal end inclined surface, the light emission angle can be changed. Coating such as mirror-coating (coated with Au or the like) or half-mirror coating (coated with a dielectric multi-layer or the like) may be applied to the distal end inclined surface according to need.

**[0019]** In the lateral light emitting device described herein, a most distal end portion of the prism may be chamfered.

**[0020]** By chamfering the most distal end portion of the prism, when the lateral light emitting device is directly

inserted into the subject body without being covered with a sheath, it is less likely that the subject body is damaged.

**[0021]** Chamfering includes a method, for example, using electric discharge or a laser in order to smooth the most distal end portion of the prism into a curved surface-like shape.

**[0022]** In the lateral light emitting device described herein, an outer diameter of the rod lens and a maximum diameter of the prism may be less than or equal to twice a diameter of the optical fiber.

**[0023]** When the outer diameters of the optical fiber and the rod lens are close to each other, the axes thereof are automatically aligned with each other by self-alignment effects due to surface tension caused in fusing. This significantly reduces coupling loss between the optical fiber and the rod lens. When the outer diameter of the optical fiber is  $125\ \mu\text{m}$ , the outer diameter of the rod lens is suitably from  $124$  to  $250\ \mu\text{m}$ . Likewise, the maximum diameter of the prism is suitably from  $124$  to  $250\ \mu\text{m}$ . When the outer diameter of the optical fiber is  $80\ \mu\text{m}$ , the outer diameter of the rod lens and the maximum diameters of the prism are suitably from  $79$  to  $160\ \mu\text{m}$ .

**[0024]** This also meets the purpose of the device that is intended to be inserted into a thin blood vessel and the like.

**[0025]** Also described herein is a method of producing a lateral light emitting device which includes the step of forming a ground base material having a planar ground surface parallel to the axis by cutting part of a circumference of a cylindrical silica glass base material, the step of forming a fiber for a prism by drawing the ground base material, the step of fusing the fiber for a prism to the rod lens or to a lens fiber, which has not been cut so as to produce the rod lens, and the step of forming the distal end inclined surface by cutting the fiber for a prism.

**[0026]** To produce the prism, the cylindrical silica glass base material is initially produced. The base material can be produced using a known method. Next, by grinding part of the circumference of the base material, the ground base material having a planar ground surface parallel to the axis is formed. This grinding can also be easily performed using typical grinding equipment. Next, the fiber for a prism is formed by drawing the ground base material. The ground base material can be drawn using drawing equipment used for optical fibers and GRIN lenses.

**[0027]** The method includes the step of fusing the fiber for a prism to the rod lens or to the lens fiber, which has not been cut so as to produce the rod lens, and the step of forming the distal end inclined surface by cutting the fiber for a prism having been fused to the rod lens or the lens fiber in order to produce the prism.

**[0028]** Since the elongated fiber for a prism is fused to the rod lens or the elongated lens fiber, which has not been cut so as to produce the rod lens, fusing task can be easily performed using known fiber fusing equipment. After this fusing, by cutting the fiber for a prism to a desired length, and by grinding the fiber for a prism according to need so as to form the distal end inclined surface,

the prism can be produced from the fiber for a prism.

**[0029]** Also described herein is a lateral light emitting device which includes an optical fiber and a prism lens fused to an end surface of the optical fiber, in which the prism lens has a basic shape that includes a planar light emitting surface parallel to an axis formed by cutting part of a circumference of a cylinder, and the prism lens includes a distal end inclined surface formed by diagonally cutting a distal end portion of the prism lens, in which light having entered the prism lens from the optical fiber is reflected by the distal end inclined surface and emitted from the light emitting surface.

**[0030]** The optical fiber and the prism lens are joined to each other by fusing. Thus, there is no adhesive layer in an optical path, and accordingly, there are no variations in beam quality, no degradation in beam quality due to detachment of the adhesion, and no complete detachment of the prism lens. Production can be easily performed using related-art known fiber fusing equipment.

**[0031]** Since the lateral light emitting device needs no shaft or sheath, the outer diameter can be made to be very small. Thus, the lateral light emitting device can be used for a very thin blood vessel and the like.

**[0032]** In addition, since the rod lens and the prism are fused to each other so as to form the prism lens in an integral manner, the numbers of components and production steps can be decreased, thereby achieving labor saving and cost reduction.

**[0033]** In most cases, the optical fiber is a single-mode optical fiber. However, the optical fiber may use a polarization maintaining fiber or a multi-mode fiber. In addition, the optical fiber may even use a bundle fiber for image transmission.

**[0034]** The prism lens needs to be formed of silica based glass in order to undergo fusing. The prism lens may use a so-called GI-type fiber, of which the core has a refractive index distribution, or a so-called GRIN lens, of which the entire section has a refractive index distribution.

**[0035]** The prism lens may also use a lens produced by fusing together two types of (or three or more types of) the above-described GRIN lenses each having a different numerical aperture.

**[0036]** The prism lens has the basic shape that includes the planar light emitting surface parallel to the axis formed by cutting part of the circumference of the cylinder. Thus, the prism lens can be easily produced by drawing (formed into a fiber) the ground lens base material (a base material formed by grinding part of the circumference of the cylindrical lens base material) having a sectional shape similar to the prism lens. The prism lens in an elongated fiber state can also be easily fused to the optical fiber.

**[0037]** A typical inclination angle ( $\theta$ ) of the distal end inclined surface of the prism lens relative to the light emitting surface is  $45^\circ$ . The light emission angle can be changed by changing the inclined angle ( $\theta$ ). Coating such as mirror-coating (coated with Au or the like) or half-mirror

coating (coated with a dielectric multi-layer or the like) may be applied to the distal end inclined surface according to need.

**[0038]** In the lateral light emitting device, a most distal end portion of the prism lens is chamfered.

**[0039]** By chamfering the most distal end portion of the prism lens, when the lateral light emitting device is directly inserted into the subject body without being covered with a sheath, it is less likely that the subject body is damaged.

**[0040]** Chamfering includes a method, for example, using electric discharge or a laser in order to smooth the most distal end portion of the prism lens into a curved surface-like shape.

**[0041]** In the lateral light emitting device a maximum diameter of the prism lens is less than or equal to twice a diameter of the optical fiber.

**[0042]** When the outer diameters of the optical fiber and the rod lens are close to each other, the axes thereof are automatically aligned with each other by self-alignment effects due to surface tension caused in fusing. This significantly reduces coupling loss between the optical fiber and the prism lens. When the outer diameter of the optical fiber is  $125\ \mu\text{m}$ , the outer diameter of the prism lens is suitably from  $124$  to  $250\ \mu\text{m}$ . When the outer diameter of the optical fiber is  $80\ \mu\text{m}$ , the outer diameter of the prism lens is suitably from  $79$  to  $160\ \mu\text{m}$ . This also meets the purpose of the device that is intended to be inserted into a thin blood vessel and the like.

**[0043]** A method of producing the lateral light emitting device includes the step of forming a ground lens base material having a planar ground surface parallel to the axis by cutting part of a circumference of a cylindrical lens base material, the step of forming a fiber for a prism lens by drawing the ground lens base material, the step of fusing the fiber for a prism lens to the optical fiber, and the step of forming the distal end inclined surface by cutting the fiber for a prism lens.

**[0044]** To produce the prism lens the cylindrical lens base material formed of silica based glass is initially produced. The lens base material can be produced using a known method (for example, Japanese Unexamined Patent Application Publication No. 2005-115097). Next, by grinding part of the circumference of the lens base material, the ground base material having the planar ground surface parallel to the axis is formed. This grinding can also be easily performed using typical grinding equipment. Next, the fiber for a prism lens is formed by drawing the ground lens base material. The ground lens base material can be drawn using drawing equipment that is used for optical fibers and GRIN lenses.

**[0045]** The method of production includes the step of fusing the fiber for a prism lens to the optical fiber, and the step of forming the distal end inclined surface by cutting the fiber for a prism lens having been fused to the optical fiber in order to produce the prism lens.

**[0046]** Since the elongated fiber for a prism lens is fused to the optical fiber, a fusing task can be easily performed using known fiber fusing equipment. After this

fusing, by cutting the fiber for a prism lens to a desired length, and by grinding the fiber for a prism lens according to need so as to form the distal end inclined surface, the prism lens can be produced from the fiber for a prism lens. Advantageous Effects of Invention

**[0047]** In the lateral light emitting device according to the present invention as defined by the claims, no adhesive is used. Thus, variations in beam quality due to an adhesive layer are eliminated.

**[0048]** Since the optical fiber and the rod lens comprising the prism so as to form an integrated prism GRIN lens are joined to each other by fusing in an integral manner, there is no possibility of detachment of the adhesion that may degrade beam quality, or no possibility of complete detachment of the prism or the rod lens that may leave the prism or the rod lens in the subject body. Thus, the lateral light emitting device needs not be covered with the sheath.

**[0049]** Since the lateral light emitting device needs no shaft or sheath the outer diameter of the lateral light emitting device can be made to be very small. Thus and by chamfering the distal end portion of the prism GRIN lens, the lateral light emitting device can be inserted into and used for a very thin blood vessel and the like.

**[0050]** Since the rod lens and the prism form an integrated prism GRIN lens in an integral manner, the numbers of components and production steps can be decreased, thereby achieving labor saving and cost reduction.

**[0051]** Since the prism GRIN lens has the basic shape that includes the planar light emitting surface parallel to the axis formed by cutting part of the circumference of the cylinder, an elongated fiber can be easily produced by drawing the base material having a sectional shape similar to the prism GRIN lens and can undergo fusing in a fiber state. Thus, a fusing task can be easily performed.

#### Brief Description of Drawings

#### **[0052]**

[Fig. 1] Fig. 1 is a side view of a reference lateral light emitting device 1.

[Fig. 2] Fig. 2 is a front view of the reference lateral light emitting device 1.

[Fig. 3] Fig. 3 is an enlarged side view of a prism 4.

[Fig. 4] Fig. 4 is a sectional view of the prism 4 illustrated in Fig. 3 taken along line A-A.

[Fig. 5] Fig. 5 is a perspective view of a base material.

[Fig. 6] Fig. 6 is a perspective view of a ground base material.

[Fig. 7] Fig. 7 is an explanatory view illustrating a production method of the reference lateral light emitting device.

[Fig. 8] Fig. 8 is an explanatory view illustrating a production method of the reference lateral light emitting device.

[Fig. 9] Fig. 9 is an explanatory view illustrating a production method of the reference lateral light emitting device.

[Fig. 10] Fig. 10 is an explanatory view illustrating a production method of the reference lateral light emitting device.

[Fig. 11] Fig. 11 is an explanatory view illustrating a production method of the reference lateral light emitting device.

[Fig. 12] Fig. 12 is an explanatory view illustrating a production method of the reference lateral light emitting device.

[Fig. 13] Fig. 13 is a side view of a lateral light emitting device 1' according to the invention.

[Fig. 14] Fig. 14 is a front view of the lateral light emitting device 1'.

[Fig. 15] Fig. 15 is a perspective view of a lens base material 8.

[Fig. 16] Fig. 16 is a perspective view of a ground lens base material 9.

[Fig. 17] Fig. 17 is an explanatory view illustrating a production method of the lateral light emitting device according to the invention.

[Fig. 18] Fig. 18 is a sectional explanatory view of a related-art lateral light emitting device.

#### Description of Embodiments

#### Embodiment

**[0053]** Figs. 1 to 4 relate to a reference lateral light emitting device 1. Fig. 1 is a side view, Fig. 2 is a front view, Fig. 3 is an enlarged side view of a prism 4, Fig. 4 is a sectional view of the prism 4 illustrated in Fig. 3 taken along line A-A.

**[0054]** The lateral light emitting device 1 includes an optical fiber 2, a rod lens 3, and the prism 4.

**[0055]** The optical fiber 2 is a single-mode optical fiber having an outer diameter of 125  $\mu\text{m}$ . A coating 2a is removed from the distal end of the optical fiber 2, and the rod lens 3 is fused to the distal end surface of the optical fiber 2.

**[0056]** The rod lens 3 is a GRIN lens formed of silica based glass and has an outer diameter of 125  $\mu\text{m}$ . When the optical fiber 2 and the rod lens 3 are fused to each other, the axes thereof are automatically aligned with each other by self-alignment effects.

**[0057]** The prism 4 is formed of silica glass and has a basic shape including a planar light emitting surface 4c (the width of the light emitting surface is 74  $\mu\text{m}$ ) parallel to the axis formed by cutting part of a circumference of a cylinder having a diameter of  $d = 125 \mu\text{m}$  by  $g = 11 \mu\text{m}$  and leaving a remaining part of  $h = 114 \mu\text{m}$ . (Fig. 4)

**[0058]** The prism 4 is produced as follows. That is, part of a circumference of a cylindrical silica glass base material 6 illustrated in Fig. 5 having a diameter  $D = 5.7 \text{ mm}$  is ground by 0.7 mm so as to produce a ground base material 7 having a remaining part of  $H \approx 5 \text{ mm}$  and the

width of a ground surface 7a of about 3 mm as illustrated in Fig. 6. The resultant material is drawn at a temperature of about 1900°C to form a fiber for a prism 4', which is cut and diagonally ground so as to form a distal end inclined surface 4a. After that, a most distal end portion 4b is chamfered using electric discharge and the distal end inclined surface 4a is Au-coated.

**[0059]** The ground surface 7a of the ground base material 7 is a planar surface parallel to the axis of the base material 6.

**[0060]** Although a typical temperature at which an optical fiber is drawn is 2000°C, it is desirable that the fiber for a prism be drawn at about 1900°C, which is a temperature lower than the typical temperature. When the drawing temperature is high, the light emitting surface 4c of the drawn fiber for a prism may be rounded. This may cause a situation in which emitted light is affected by the curvature of the light emitting surface and has an elliptic shape, thereby enlarging an illumination area, and accordingly, preventing sufficient spatial resolution from being obtained. When the drawing temperature is set to about 1900°C, the curvature of the light emitting surface 4c is very small and the light emitting surface 4c becomes a substantially planar surface, which causes no problem in practical use.

**[0061]** Light emitted from the optical fiber 2 enters the rod lens 3 while diverging, advances in the rod lens 3 while converging, enters the prism 4, is reflected by the distal end inclined surface 4a, and is emitted from the light emitting surface 4c.

**[0062]** The reference lateral light emitting device 1 can be easily produced using methods illustrated in Figs. 7 to 12.

**[0063]** Referring to Fig. 7, (a) illustrates a state in which a lens fiber 3' is fused to one end of the optical fiber 2, (b) illustrates a state in which the lens fiber 3' is cut to a specified length (after the cutting, the cut surface may be ground according to need) so as to produce the rod lens 3, (c) illustrates a state in which the fiber for a prism 4' is fused to an end surface of the rod lens 3, and (d) illustrates a state in which the fiber for a prism 4' is cut and ground so as to form the distal end inclined surface, and then the most distal end portion 4b is chamfered and the distal end inclined surface 4a is Au-coated so as to produce the prism 4.

**[0064]** The lens fiber 3' is a fiber-like material that is formed by drawing a GRIN lens base material.

**[0065]** Referring to Fig. 8, (a) illustrates a state in which the rod lens 3, which has been produced in advance, is fused to one end of the optical fiber 2, (b) illustrates a state in which the fiber for a prism 4' is fused to the end surface of the rod lens 3, and (c) illustrates a state in which the fiber for a prism 4' is cut and ground so as to form the distal end inclined surface, and then the most distal end portion 4b is chamfered and the distal end inclined surface 4a is Au-coated so as to produce the prism 4.

**[0066]** Referring to Fig. 9, (a) illustrates a state in which

the fiber for a prism 4' is fused to one end of the lens fiber 3', (b) illustrates a state in which the lens fiber 3' is cut to a specified length (after the cutting, the cut surface may be ground according to need) so as to produce the rod lens 3, (c) illustrates a state in which the end surface of the rod lens 3 is fused to one end of the optical fiber 2, and (d) illustrates a state in which the fiber for a prism 4' is cut and ground so as to form the distal end inclined surface, and then the most distal end portion 4b is chamfered and the distal end inclined surface 4a is Au-coated so as to produce the prism 4.

**[0067]** Referring to Fig. 10, (a) illustrates a state in which the fiber for a prism 4' is fused to one end of the rod lens 3 that has been produced in advance, (b) illustrates a state in which the end surface of the rod lens 3 is fused to one end of the optical fiber 2, and (c) illustrates a state in which the fiber for a prism 4' is cut and ground so as to form the distal end inclined surface, and then the most distal end portion 4b is chamfered and the distal end inclined surface 4a is Au-coated so as to produce the prism 4.

**[0068]** Referring to Fig. 11, (a) illustrates a state in which the fiber for a prism 4' is fused to one end of the lens fiber 3', (b) illustrates a state in which the lens fiber 3' is cut to a specified length (after the cutting, the cut surface may be ground according to need) so as to produce the rod lens 3, the fiber for a prism is cut and ground so as to form the distal end inclined surface, and then the most distal end portion 4b is chamfered and the distal end inclined surface 4a is Au-coated so as to produce the prism 4, thereby producing a rod lens with a prism, and (c) illustrates a state in which the rod lens with a prism is fused to the optical fiber 2.

**[0069]** Referring to Fig. 12, (a) illustrates a state in which the fiber for a prism 4' is fused to one end of the rod lens 3 that has been produced in advance, (b) illustrates a state in which the fiber for a prism is cut and ground so as to form the distal end inclined surface, and then the most distal end portion 4b is chamfered and the distal end inclined surface 4a is Au-coated so as to produce the prism 4, thereby producing the rod lens with a prism, and (c) illustrates a state in which the rod lens with a prism is fused to one end of the optical fiber 2.

**[0070]** In the lateral light emitting device 1' according to the invention illustrated in Fig. 13, a prism lens 5 is fused to an end surface of the optical fiber 2. The optical fiber 2 is a single-mode optical fiber having the outer diameter of 125 μm. The coating 2a is removed at the distal end of the optical fiber 2.

**[0071]** The prism lens 5 is a GRIN lens having a numerical aperture of 0.17 and has a basic shape including a planar light emitting surface 5c (the width of the light emitting surface is 74 μm) parallel to the axis formed by cutting part of a circumference of a cylinder having a diameter of  $d = 125 \mu\text{m}$  by  $g = 11 \mu\text{m}$  and leaving a remaining part of  $h = 114 \mu\text{m}$ . (Fig. 14) The distal end portion of the prism lens 5 is diagonally cut so as to form a distal end inclined surface 5a.

**[0072]** The entire length of the prism lens 5 is 300  $\mu\text{m}$ .

**[0073]** The prism lens 5 is produced as follows. That is, part of the circumference of a cylindrical GLIN lens base material 8 illustrated in Fig. 15 having a diameter of  $D = 5.0 \text{ mm}$  is ground by about 0.5 mm so as to produce a ground lens base material 9 having a remaining part of  $H \approx 4.5 \text{ mm}$  and the width of a ground surface 9a of about 3 mm as illustrated in Fig. 16. The resultant material is drawn at a temperature of about 1800°C to form a fiber for a prism lens 5', which is cut and diagonally ground so as to form the distal end inclined surface 5a. After that, a most distal end portion 5b is chamfered using electric discharge and the distal end inclined surface 5a is Au-coated.

**[0074]** The ground surface 9a of the ground lens base material 9 is a planar surface parallel to the axis of the lens base material 8.

**[0075]** Although a typical temperature at which a GRIN lens fiber having a numerical aperture of 0.17 is drawn is 1900°C, it is desirable that the fiber for a prism lens be drawn at about 1800°C, which is a temperature lower than the typical temperature. When the drawing temperature is high, the light emitting surface 5c of the drawn fiber for a prism lens may be rounded. This may cause a situation in which emitted light is affected by the curvature of the light emitting surface and has an elliptical shape, thereby enlarging an illumination area, and accordingly, preventing sufficient spatial resolution from being obtained. When the drawing temperature is set to about 1800°C, the curvature of the light emitting surface 5c is very small and the light emitting surface 5c becomes a substantially planar surface, which causes no problem in practical use.

**[0076]** Light emitted from the optical fiber 2 enters the prism lens 5 while diverging, advances in the prism lens 5 while converging, is reflected by the distal end inclined surface 5a, and is emitted from the light emitting surface 5c.

**[0077]** The lateral light emitting device 1' according to the invention is easily produced by a production method illustrated in Figs. 17.

**[0078]** Referring to Fig. 17, (a) illustrates a state in which the fiber for a prism lens 5' is fused to a distal end of the optical fiber 2, (b) illustrates a state in which the fiber for a prism lens 5' is cut and ground so as to form the distal end inclined surface, and then the most distal end portion 5b is chamfered and the distal end inclined surface 5a is Au-coated so as to produce the prism lens 5.

**[0079]** The lateral light emitting device 1' having a diameter the same as that of the optical fiber is very thin and suitably used for very thin blood vessels and the like.

**[0080]** The distal end inclined surface of the prism or the prism lens can be also formed by cutting the fiber for a prism or the fiber for a prism lens using a laser so as to form the inclined surface other than cutting and grinding.

## Industrial Applicability

**[0081]** The lateral light emitting device according to the present invention can be used as an optical probe for OCT and as optical probe for an endoscope.

## Reference Signs List

### [0082]

- |    |                                 |
|----|---------------------------------|
| 10 | 1 lateral light emitting device |
|    | 2 optical fiber                 |
|    | 2a coating                      |
|    | 3 rod lens                      |
| 15 | 3' lens fiber                   |
|    | 4 prism                         |
|    | 4a distal end inclined surface  |
|    | 4b most distal end portion      |
|    | 4c light emitting surface       |
| 20 | 4' fiber for a prism            |
|    | 5 prism lens                    |
|    | 5a distal end inclined surface  |
|    | 5b most distal end portion      |
|    | 5c light emitting surface       |
| 25 | 5' fiber for a prism lens       |
|    | 6 base material                 |
|    | 7 ground base material          |
|    | 7a ground surface               |
|    | 8 lens base material            |
| 30 | 9 ground lens base material     |
|    | 9a ground surface               |
|    | 10 shaft                        |
|    | 11 distal end holding portion   |
|    | 12 sheath                       |
| 35 | B emitted light                 |

## Claims

- 40 **1.** A lateral light emitting device (1') suitable for use as an optical probe for optical coherence tomography, the lateral light emitting device (1') comprising an optical fiber (2) and a prism GRIN lens (5) fused to an end surface of the optical fiber (2), wherein the prism GRIN lens (5) has a basic cylindrical shape including a planar light emitting surface (5c) parallel to an axis of the cylinder, the prism GRIN lens (5) including a distal end inclined surface (5a), wherein light having entered the prism GRIN lens (5) from the optical fiber (2) is reflected by the distal end inclined surface (5a) and emitted from the light emitting surface (5c), wherein a most distal end portion (5b) of the prism GRIN lens (5) is chamfered by smoothing it into a curved surface like shape.
- 45
- 50
- 55 **2.** The lateral light emitting device according to Claim 1, wherein a maximum diameter of the prism GRIN lens (5) is less than or equal to twice a diameter of

the optical fiber (2) .

3. A method of producing the lateral light emitting device according to any one of Claims 1 to 2 comprising the step of forming a ground GRIN lens base material (9) having a planar ground surface (9a) parallel to the axis by cutting part of a circumference of a cylindrical GRIN lens base material (8), the step of forming a fiber for a prism GRIN lens (5) by drawing the ground GRIN lens base material (9a), the step of fusing the fiber for a prism GRIN lens (5) to the optical fiber (2), and the step of forming the distal end inclined surface (5a) by cutting the fiber for a prism GRIN lens (5) and chamfering a most distal end portion (5b) of the prism GRIN lens (5) by smoothing it into a curved surface like shape.

### Patentansprüche

1. Laterales Licht emittierende Vorrichtung (1'), geeignet für die Verwendung als optische Sonde bei der optischen Kohärenztomographie, wobei die laterales Licht emittierende Vorrichtung (1') umfasst: eine optische Faser (2) und eine Prisma-GRIN-Linse (5), die an eine Stirnfläche der optischen Faser (2) geschmolzen ist, wobei die Prisma-GRIN-Linse (5) eine zylindrische Grundgestalt hat mit einer planaren Licht emittierenden Oberfläche (5c) parallel zu einer Achse des Zylinders und die Prisma-GRIN-Linse (5) eine schräge distale Stirnfläche (5a) umfasst, wobei Licht, das in die Prisma-GRIN-Linse (5) von der optischen Faser (2) eingetreten ist, durch die schräge distale Stirnfläche (5a) reflektiert und von der Licht emittierenden Oberfläche (5c) emittiert wird, wobei ein am äußersten distalen Ende gelegener Abschnitt (5b) der Prisma-GRIN-Linse (5) abgeschrägt ist durch Glätten in eine Gestalt ähnlich einer gekrümmten Oberfläche.
2. Laterales Licht emittierende Vorrichtung nach Anspruch 1, wobei ein maximaler Durchmesser der Prisma-GRIN-Linse (5) kleiner oder gleich dem doppelten Durchmesser der optischen Faser (2) ist.
3. Verfahren zur Herstellung der laterales Licht emittierenden Vorrichtung nach einem der Ansprüche 1 bis 2, umfassend den Schritt Herstellen eines beschliffenen GRIN-Linsen-Grundwerkstoffs (9) mit einer planar beschliffenen Oberfläche (9a) parallel zu der Achse durch Abtragen von einem Teil eines Umfangs von einem zylindrischen GRIN-Linsen-Grundwerkstoff (8), den Schritt Herstellen einer Faser für eine Prisma-GRIN-Linse (5) durch Ziehen des beschliffenen GRIN-Linsen-Grundwerkstoffs (9a), den Schritt Schmelzen der Faser für eine Prisma-GRIN-Linse (5) an die optische Faser (2) und den Schritt Herstellen der schrägen distalen Stirnfläche (5a)

durch Abtragen der Faser für eine Prisma-GRIN-Linse (5) und Abschrägen eines am äußersten distalen Ende gelegenen Abschnitts (5b) der Prisma-GRIN-Linse (5) durch Glätten in eine Gestalt ähnlich einer gekrümmten Oberfläche.

### Revendications

1. Dispositif d'émission de lumière latérale (1') apte à être utilisé comme une sonde optique pour une tomographie de cohérence optique, le dispositif d'émission de lumière latérale (1') comprenant une fibre optique (2) et une lentille à prisme GRIN (5) fondue à une surface d'extrémité de la fibre optique (2), où la lentille à prisme GRIN (5) a une forme cylindrique de base incluant une surface d'émission de lumière plane (5c) parallèle à un axe du cylindre, la lentille à prisme GRIN (5) incluant une surface inclinée d'extrémité distale (5a), où la lumière entrée dans la lentille à prisme GRIN (5) de la fibre optique (2) est réfléchiée par la surface inclinée d'extrémité distale (5a) et est émise de la surface d'émission de lumière (5c), où une portion d'extrémité la plus distale (5b) de la lentille à prisme GRIN (5) est chanfreinée en la lissant en une forme semblable à une surface courbée.
2. Dispositif d'émission de lumière latérale selon la revendication 1, dans lequel un diamètre maximum de la lentille à prisme GRIN (5) est inférieur ou égal au double du diamètre de la fibre optique (2).
3. Procédé de production du dispositif d'émission de lumière latérale selon l'une quelconque des revendications 1 à 2, comprenant l'étape consistant à former un matériau de base de lentille GRIN meulé (9) ayant une surface meulée plane (9a) d'une manière parallèle à l'axe en coupant une partie d'une circonférence d'un matériau de base de lentille GRIN cylindrique (8), l'étape de formation d'une fibre pour une lentille à prisme GRIN (5) en étirant le matériau de base de lentille GRIN meulé (9a), l'étape de la fusion de la fibre pour une lentille à prisme GRIN (5) à la fibre optique (2), et l'étape consistant à former la surface inclinée d'extrémité distale (5a) en coupant la fibre pour une lentille à prisme GRIN (5) et en chanfreinant une portion d'extrémité la plus distale (5b) de la lentille à prisme GRIN (5) en la lissant en une forme semblable à une surface courbée.

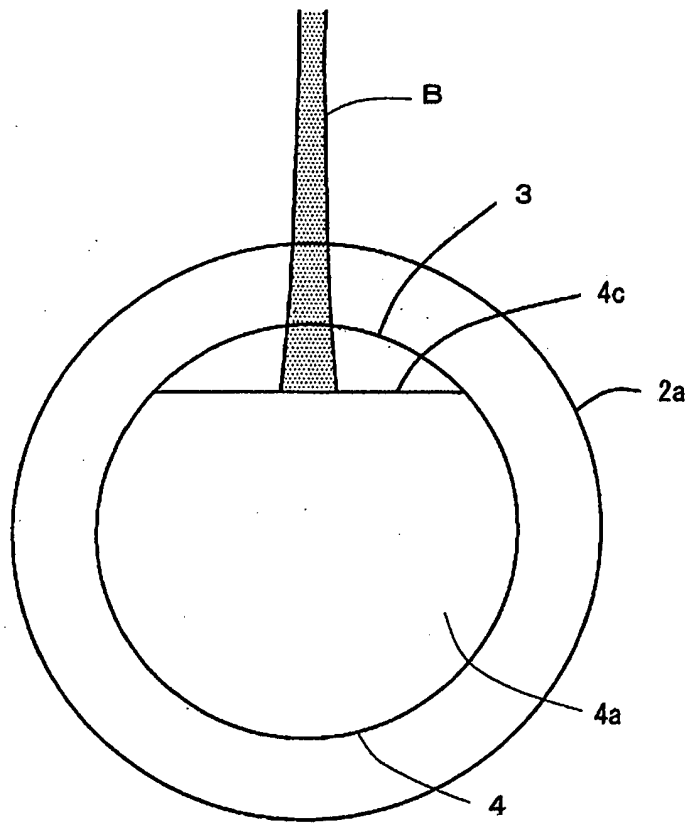
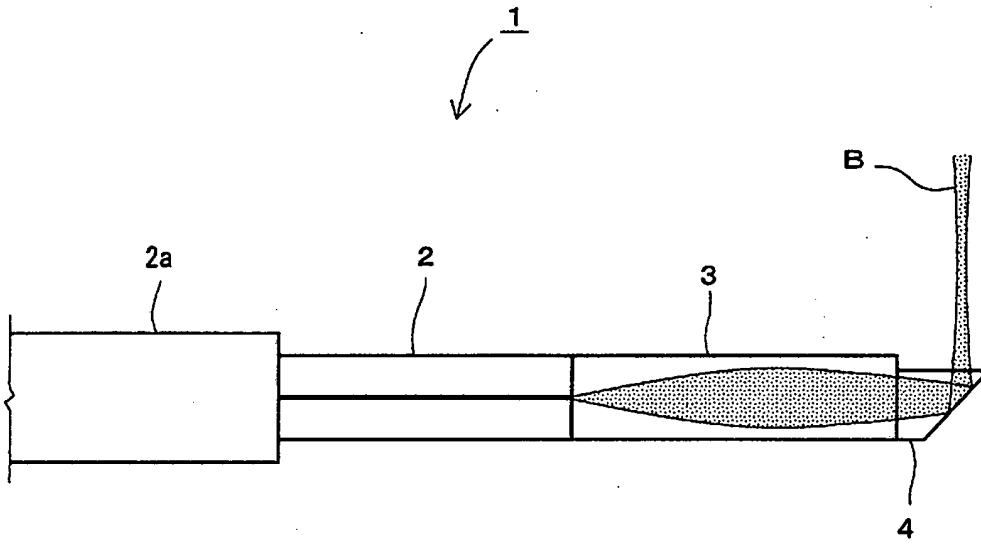

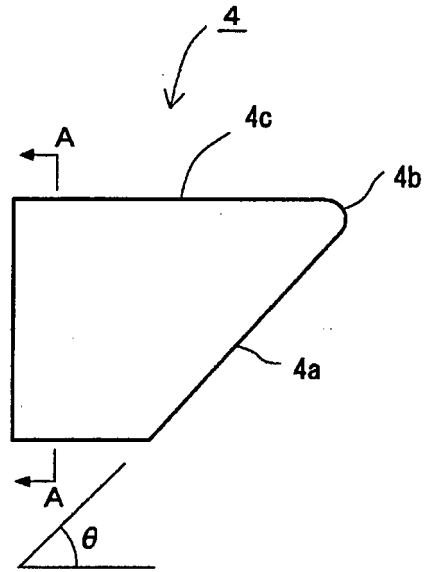

Fig. 3

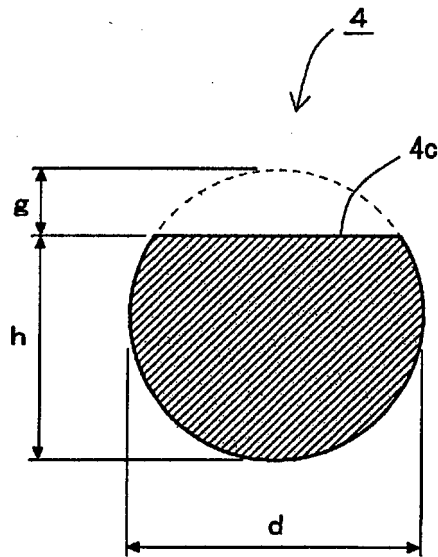

Fig. 4

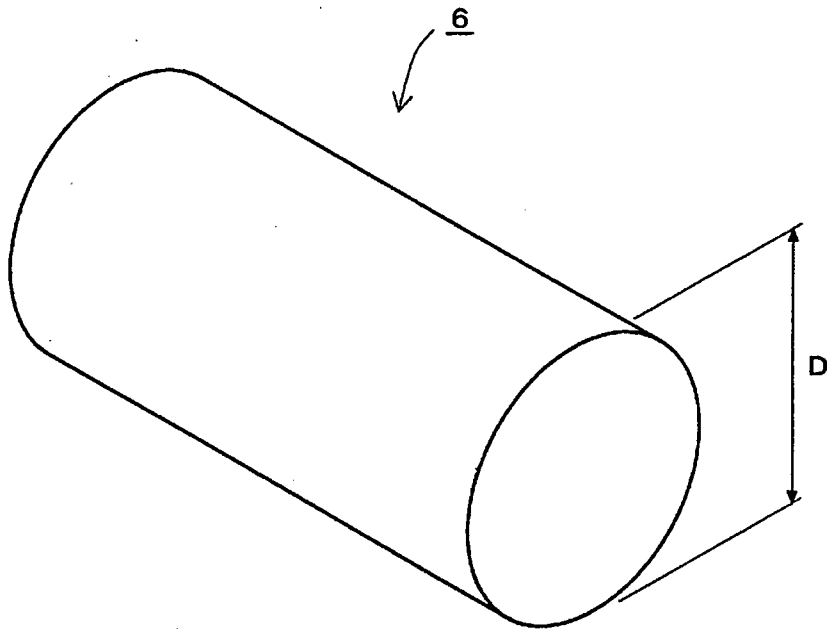

Fig. 5

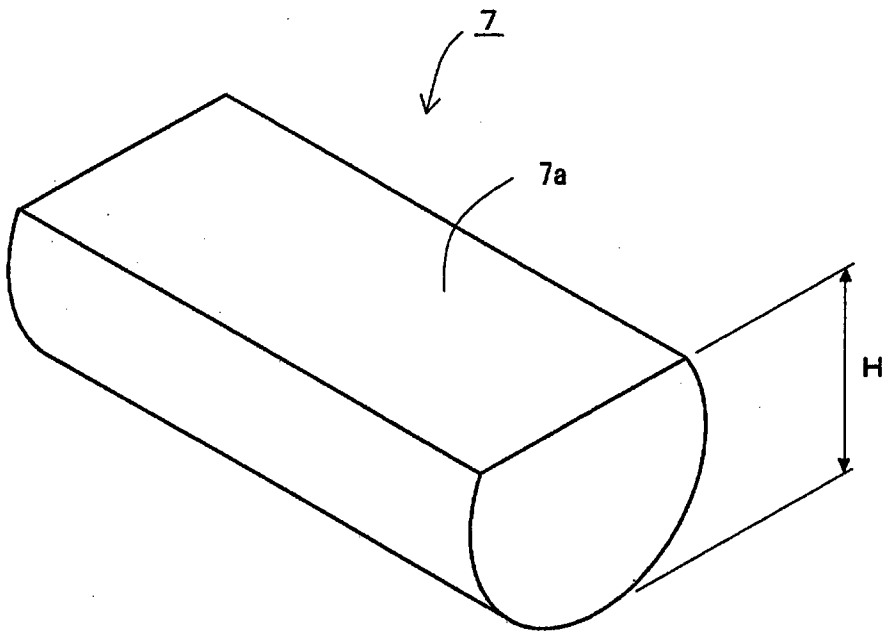

Fig. 6

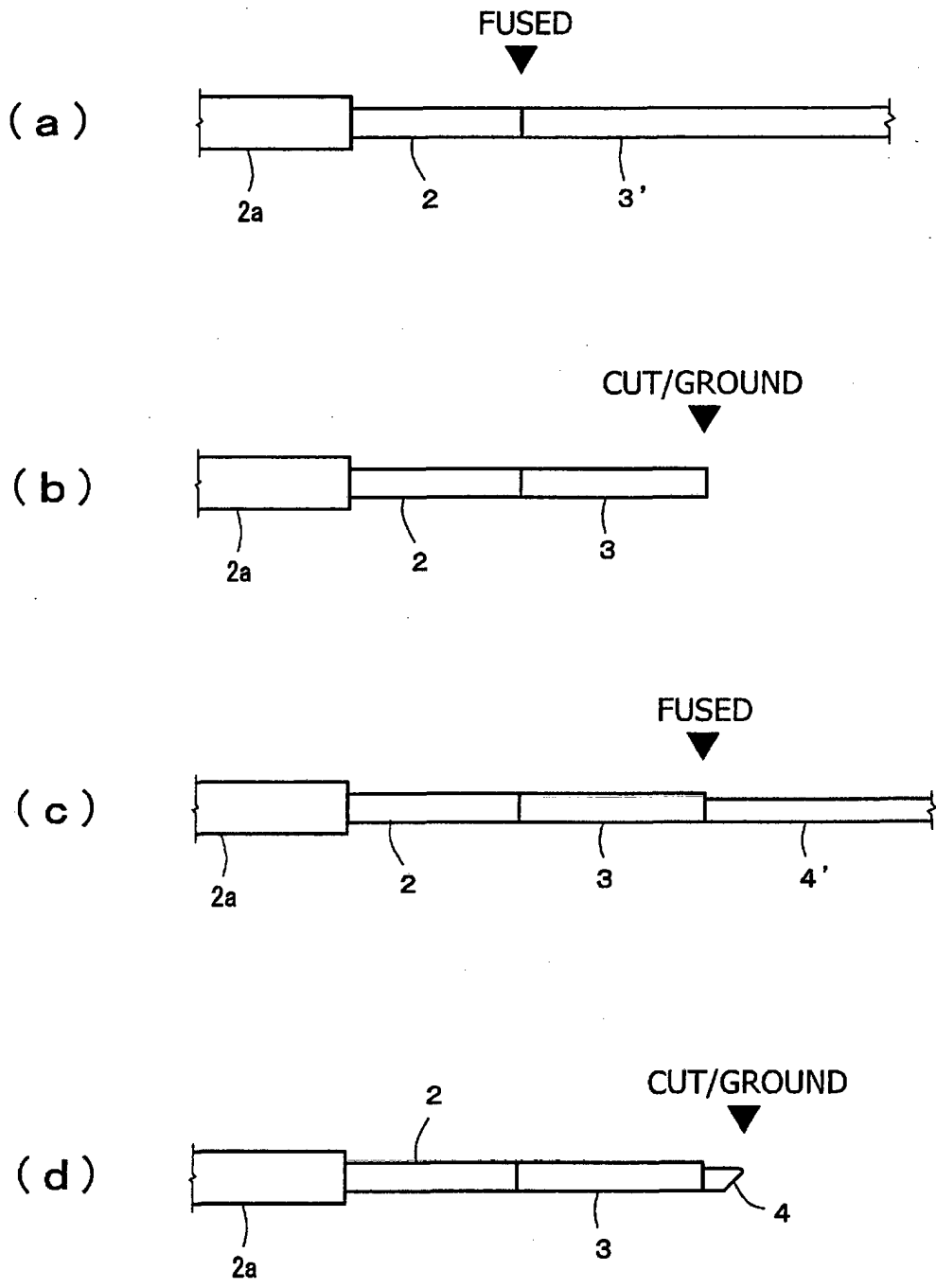

Fig. 7

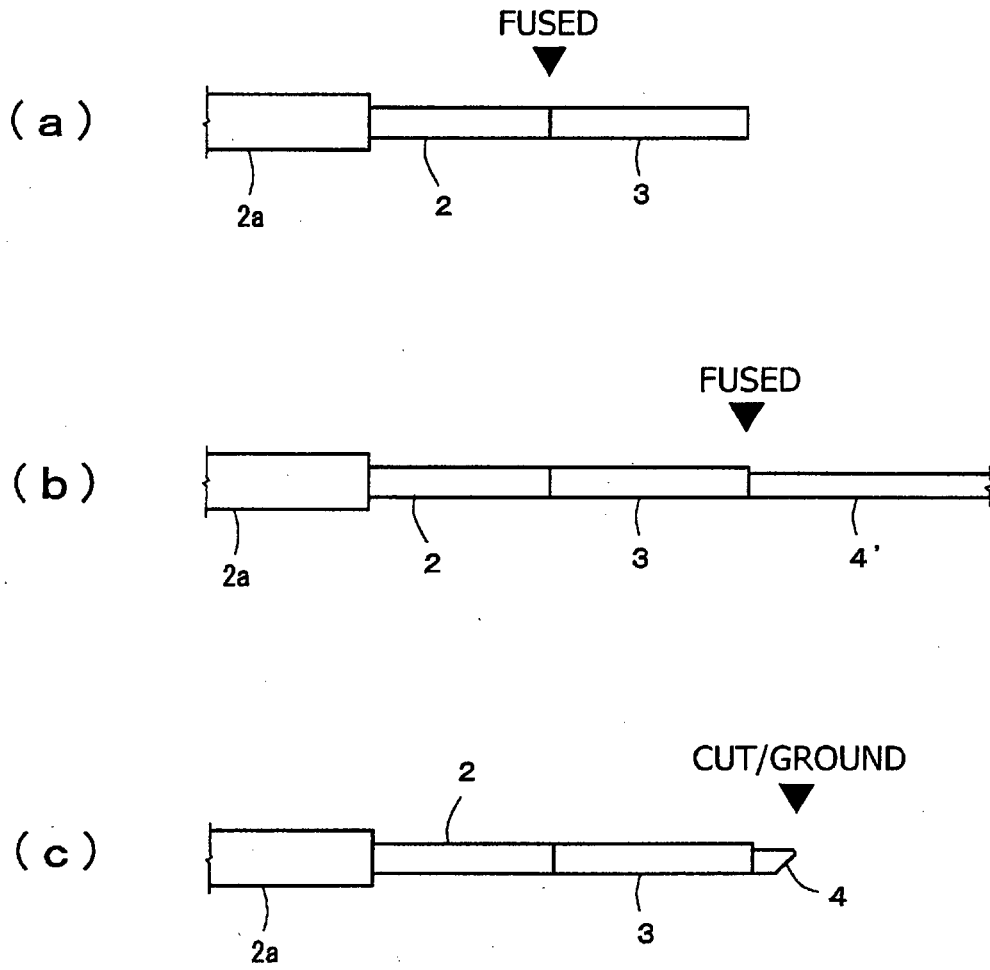

Fig. 8

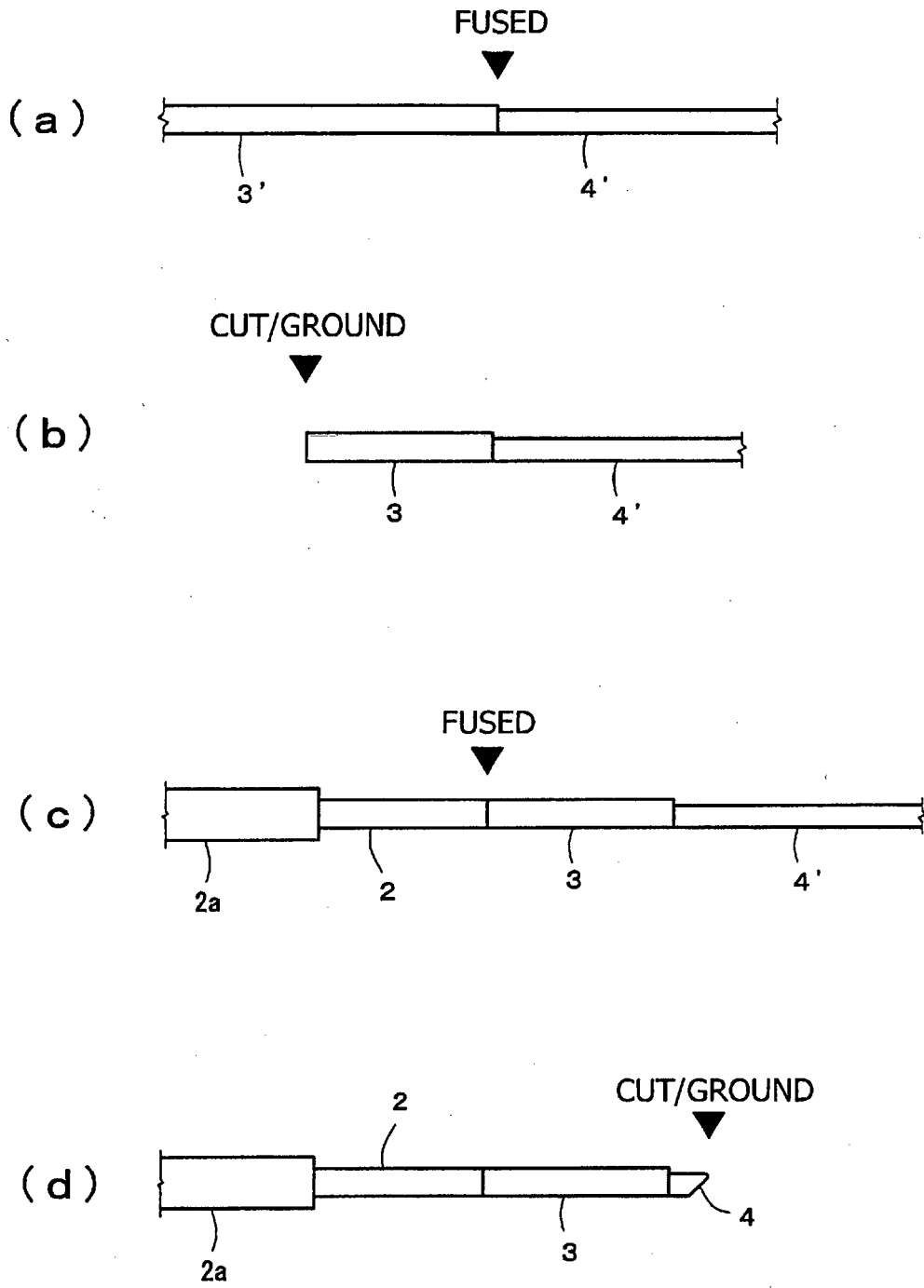

Fig. 9

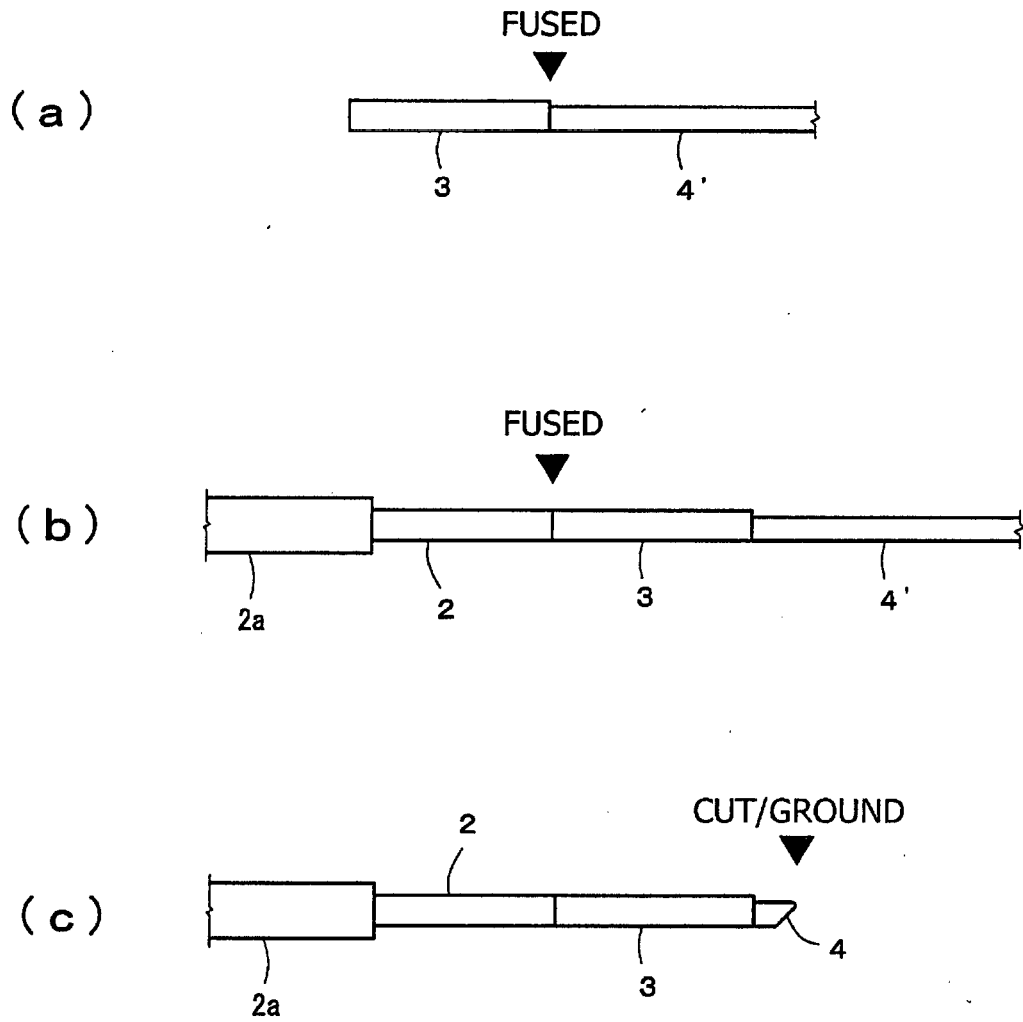

Fig. 10

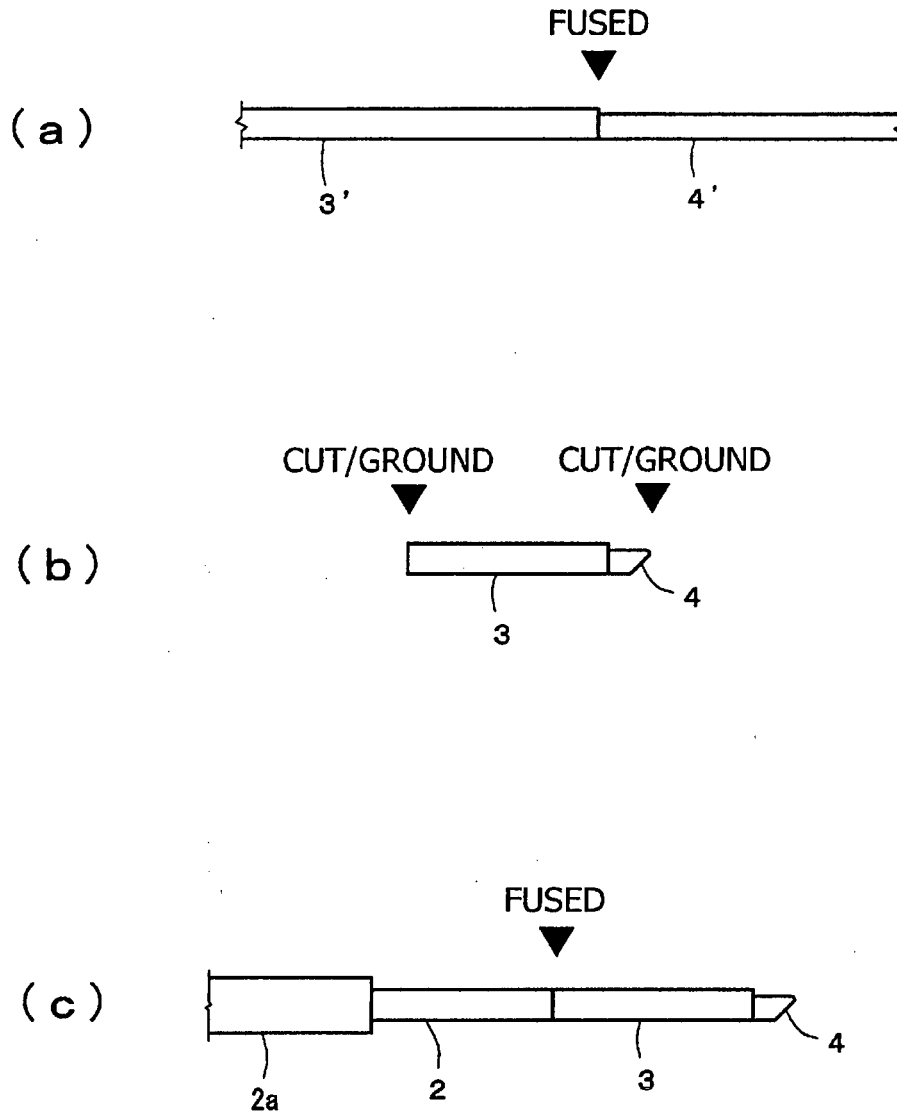

Fig. 11

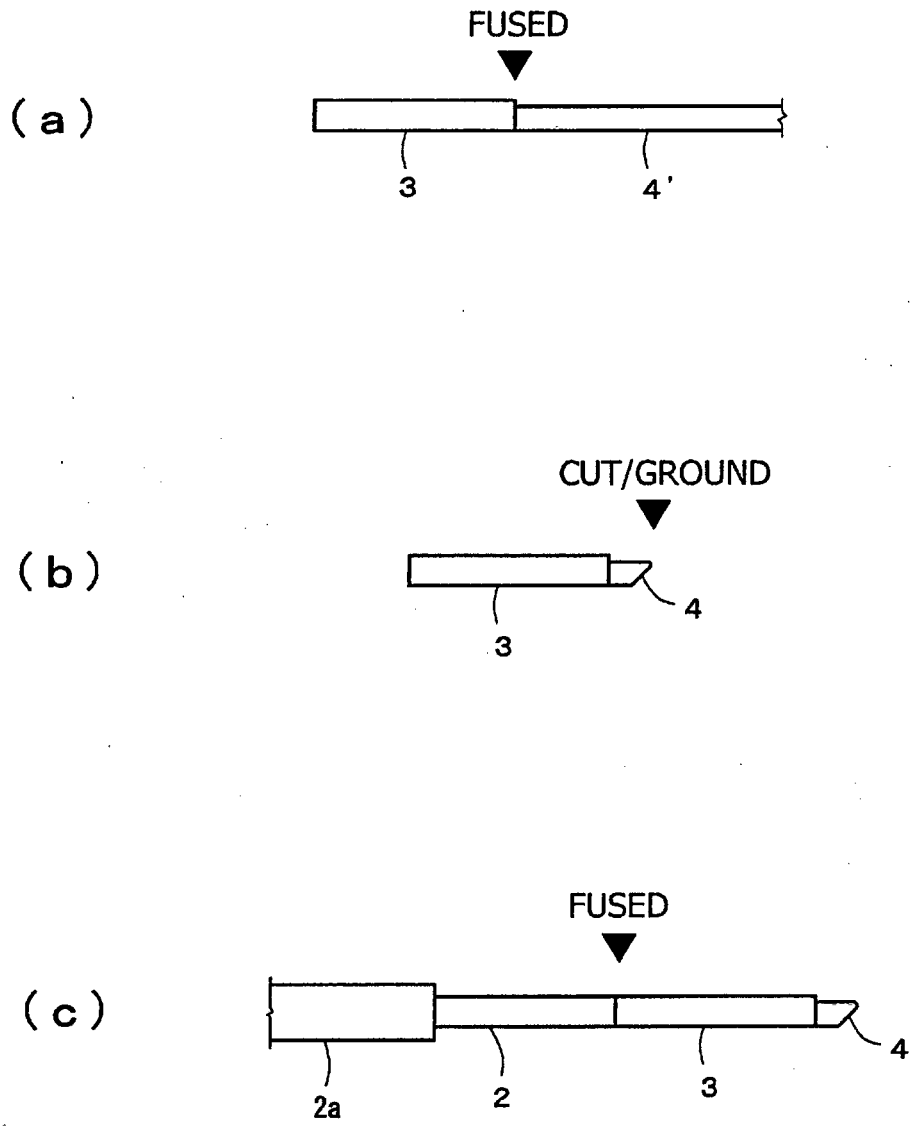

Fig. 12

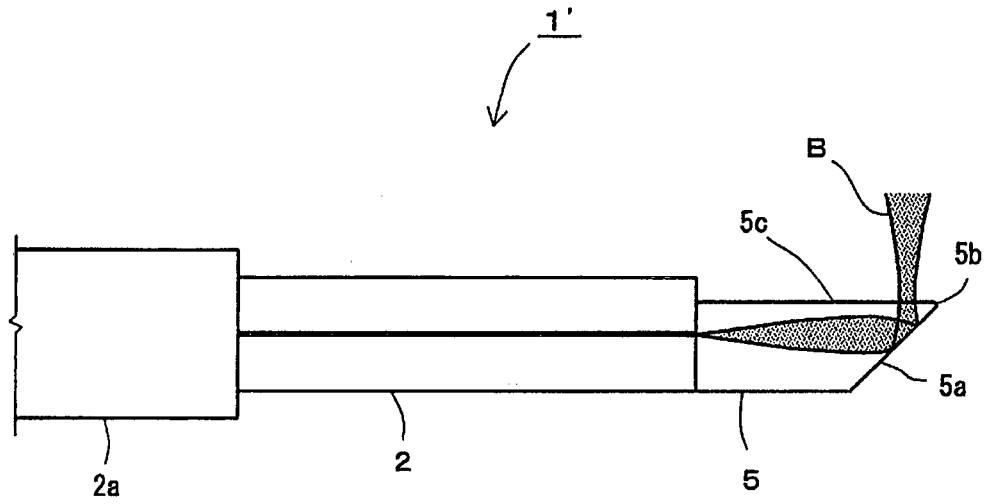

Fig. 13

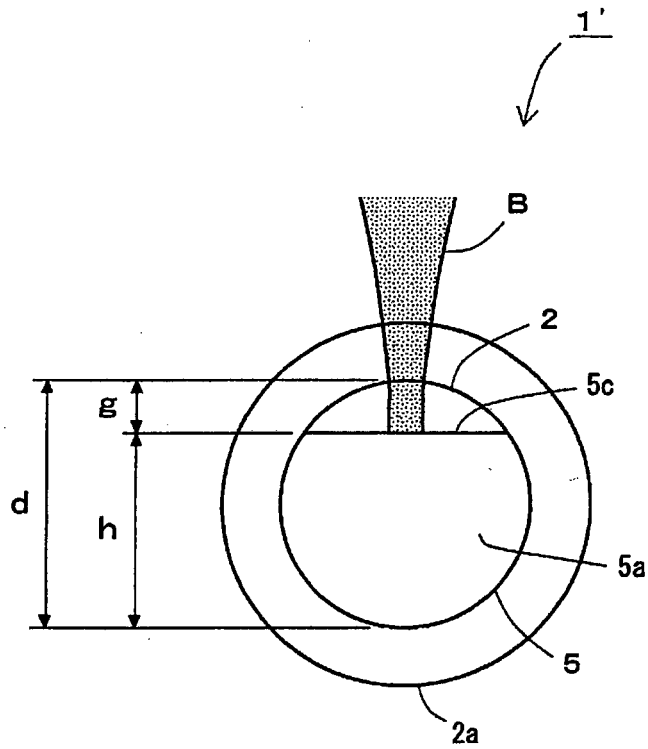

Fig. 14

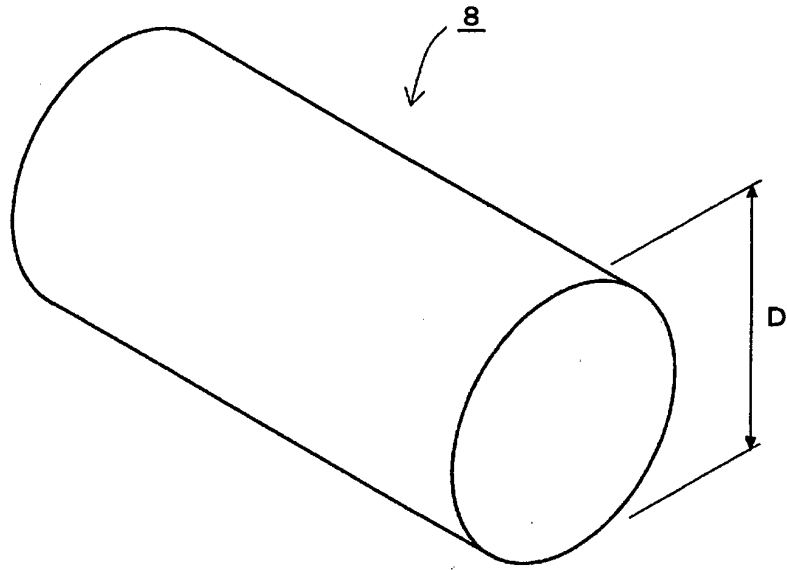

Fig. 15

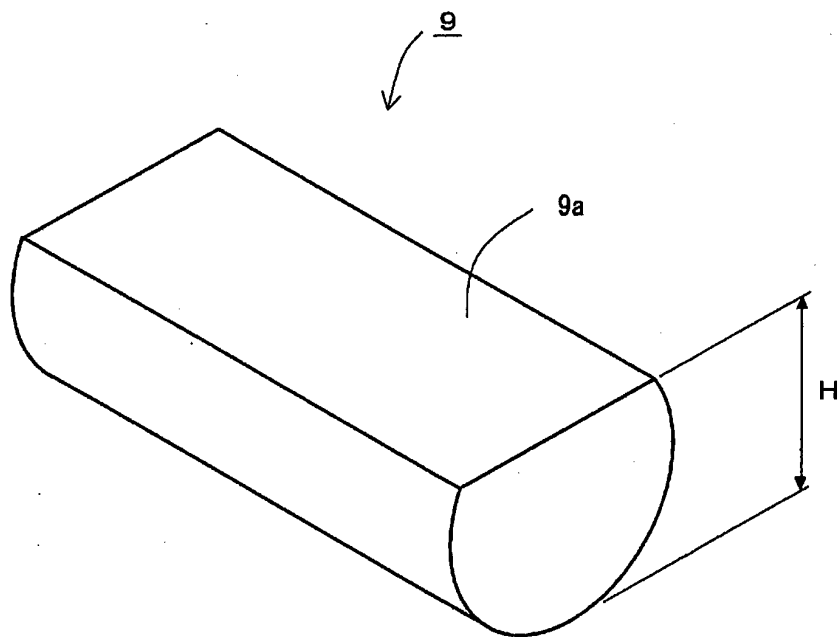

Fig. 16

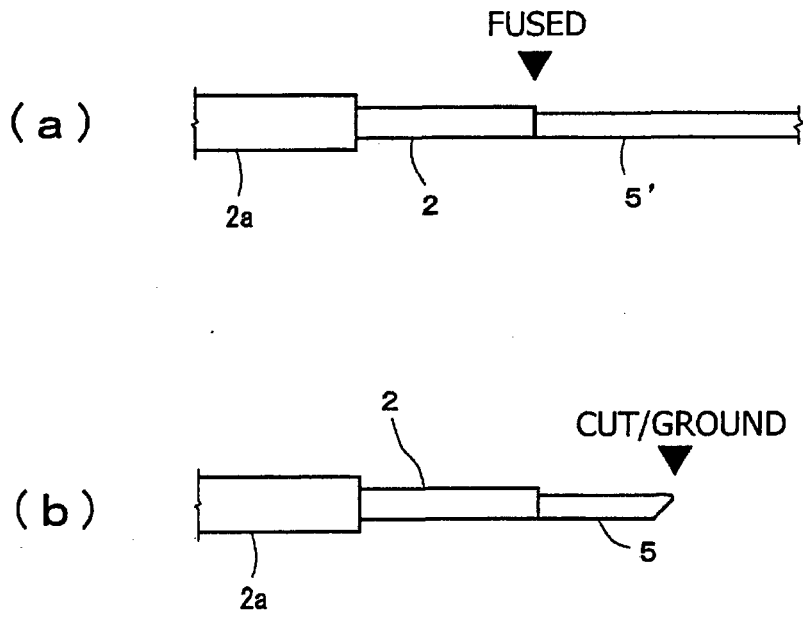

Fig. 17

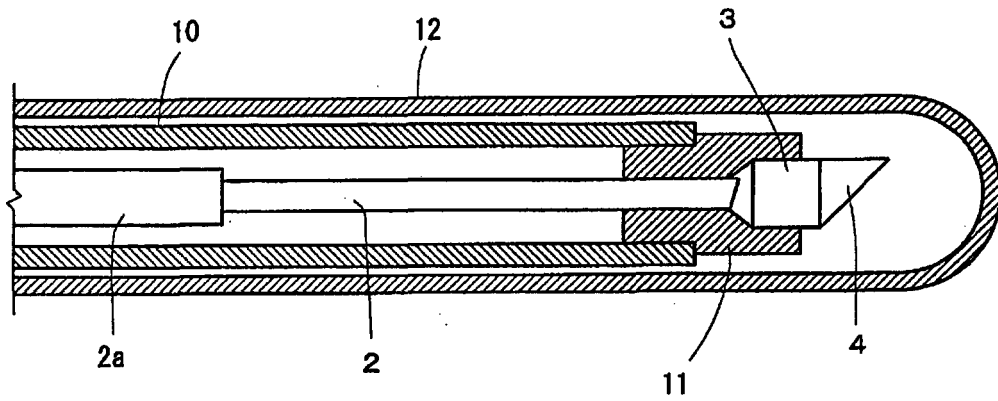

Fig. 18

**REFERENCES CITED IN THE DESCRIPTION**

*This list of references cited by the applicant is for the reader's convenience only. It does not form part of the European patent document. Even though great care has been taken in compiling the references, errors or omissions cannot be excluded and the EPO disclaims all liability in this regard.*

**Patent documents cited in the description**

- JP 6035946 A [0002] [0005]
- JP 11056786 A [0002] [0005]
- JP 2008200283 A [0002] [0005]
- WO 0111409 A [0004]
- US 20090262361 A [0004]
- US 20080002529 A [0004]
- JP 2005115097 A [0016] [0044]

专利名称(译)	横向发光器件及其制造方法		
公开(公告)号	<a href="#">EP2412298B1</a>	公开(公告)日	2014-11-26
申请号	EP2010846992	申请日	2010-03-03
[标]申请(专利权)人(译)	东洋玻璃株式会社		
申请(专利权)人(译)	东洋GLASS CO. , LTD.		
当前申请(专利权)人(译)	东洋制罐集团控股有限公司.		
[标]发明人	MARUYAMA NAOFUMI FUKUDA TOSHIAKI		
发明人	MARUYAMA NAOFUMI FUKUDA TOSHIAKI		
IPC分类号	G02B6/32 G02B6/26 A61B5/00 A61B1/00 A61B5/02 G02B6/255		
CPC分类号	A61B5/02007 A61B1/00165 A61B5/0066 A61B5/0084 G02B6/0008 G02B6/2551 G02B6/2552 G02B6/262 G02B6/32		
代理机构(译)	布朗, 大卫LESLIE		
其他公开文献	EP2412298A1 EP2412298A4		
外部链接	<a href="#">Espacenet</a>		

摘要(译)

可以容易地制造没有光束质量的变化和劣化并且由粘合剂引起的可靠性降低的横向发光装置，并且开发了具有小直径以便可用于薄血管等的横向发光装置。通过将棒透镜的一端熔合到光纤的端面，并通过将棱镜熔合到棒透镜的另一端来解决该问题。棱镜具有基本形状，包括平行于通过切割圆柱体的一部分而形成的轴的平面发光表面，并且具有远端倾斜表面，其远端部分被对角切割。或者，通过将棱镜透镜熔合到光纤的端面来解决该问题。棱镜透镜具有基本形状，该基本形状包括平行于通过切割圆柱体的一部分而形成的轴的平面发光表面，并且具有远端倾斜表面，其远端部分被对角切割。

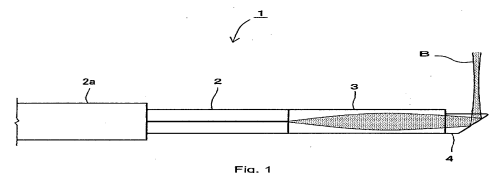

Fig. 1

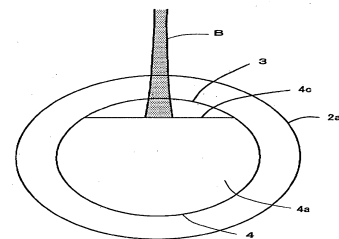

Fig. 2