



(11) **EP 2 353 640 B1**

(12) **EUROPEAN PATENT SPECIFICATION**

(45) Date of publication and mention of the grant of the patent:  
**08.04.2020 Bulletin 2020/15**

(51) Int Cl.:  
**A61N 1/36** <sup>(2006.01)</sup> **A61B 5/00** <sup>(2006.01)</sup>  
**A61N 1/04** <sup>(2006.01)</sup>

(21) Application number: **11153842.7**

(22) Date of filing: **09.02.2011**

(54) **Pain sensory nerve stimulation apparatus**

Schmerzsensornerve-Stimulationsvorrichtung

Appareil de stimulation nerveuse sensorielle de la douleur

(84) Designated Contracting States:  
**AL AT BE BG CH CY CZ DE DK EE ES FI FR GB GR HR HU IE IS IT LI LT LU LV MC MK MT NL NO PL PT RO RS SE SI SK SM TR**

(30) Priority: **09.02.2010 JP 2010026278**

(43) Date of publication of application:  
**10.08.2011 Bulletin 2011/32**

(73) Proprietors:  
• **Nihon Kohden Corporation**  
**Shinjuku-ku**  
**Tokyo (JP)**  
• **Inter-University Research Institute Corporation**  
**National Institutes of Natural Sciences**  
**Tokyo (JP)**

(72) Inventors:  
• **Inui, Koji**  
**Okazaki-shi Aichi (JP)**  
• **Takeshima, Yasuyuki**  
**Okazaki-shi Aichi (JP)**

- **Motogi, Jun**  
**Shinjuku-ku Tokyo (JP)**
- **Ono, Yoshinobu**  
**Shinjuku-ku Tokyo (JP)**
- **Kojima, Takeshi**  
**Shinjuku-ku Tokyo (JP)**
- **Ushijima, Ryosuke**  
**Shinjuku-ku Tokyo (JP)**
- **Nakaichi, Katsumi**  
**Shinjuku-ku Tokyo (JP)**
- **Shibuya, Kazuwa**  
**Shinjuku-ku Tokyo (JP)**

(74) Representative: **Grünecker Patent- und Rechtsanwälte**  
**PartG mbB**  
**Leopoldstraße 4**  
**80802 München (DE)**

(56) References cited:  
**EP-A1- 2 174 589** **WO-A1-97/06730**  
**WO-A1-2005/046787** **WO-A1-2006/059430**  
**US-A- 2 771 554**

**EP 2 353 640 B1**

Note: Within nine months of the publication of the mention of the grant of the European patent in the European Patent Bulletin, any person may give notice to the European Patent Office of opposition to that patent, in accordance with the Implementing Regulations. Notice of opposition shall not be deemed to have been filed until the opposition fee has been paid. (Art. 99(1) European Patent Convention).

## Description

### BACKGROUND OF THE INVENTION

**[0001]** The present invention relates to a pain sensory nerve stimulation apparatus which, with respect to the primary pain sense produced by stimulation of A $\delta$  fibers, and the secondary pain sense produced by stimulation of C fibers, can perform only stimulation of C fiber.

**[0002]** In order to stimulate only the pain sense by electrical stimulation, an electrode disclosed in Patent Reference 1 has been developed. According to the electrode, it is possible to stimulate A $\delta$  fibers (see Fig. 3 of Patent Reference 1).

**[0003]** By contrast, in order to early detect a disorder of peripheral nerve which is one of the three major complications of diabetes, a method in which only C fibers are stimulated and a reaction to the stimulation is checked is highly requested. This is based on that C fibers have a thickness of 0.4 to 1.2  $\mu\text{m}$ , A $\delta$  fibers have a thickness of 2 to 5  $\mu\text{m}$ , A $\beta$  fibers which are connected to mechanoreceptors of the tactile sense, the pressure sense, and the like have a thickness of 5 to 12  $\mu\text{m}$ , and a nervous disorder begins from small fibers. When it is possible to stimulate C fibers which are smaller than A $\delta$  fibers that can be stimulated in Patent Reference 1, therefore, development of a nervous disorder can be known more early, thereby largely contributing to knowing of progression of and adequate control of a diabetic nervous disorder. In a related-art technique of stimulating only C fibers, a laser apparatus is used. In the case where a laser apparatus is used, however, large-scale testing equipment and facility are required, and the size, cost, and complexity of the apparatus are increased to cause a problem of versatility. The accuracy of C fiber stimulation by laser light has not yet reached to a satisfactory level, and the probability of C fiber stimulation is lower. Therefore, a laser apparatus has not been used in a clinical application.

**[0004]** Also in Patent Reference 1, when stimulation is applied while a needle terminal of the stimulation electrode is set as a negative pole and the surrounding electrode is set as a positive pole, it is possible to selectively stimulate A $\delta$  fibers, but C fibers cannot be selectively stimulated.

**[0005]** In the field of the art, a related-art technique in which electrical stimulation of the negative polarity is applied to a stimulation object electrode attached to a desired stimulation portion, and the positive polarity is applied to an end electrode is employed because excitation of peripheral nerves is generated immediately below a stimulation electrode of the negative polarity. Also Patent Reference 1 describes that stimulation is applied while the needle electrode of the stimulation electrode is set as a negative pole and the surrounding electrode is set as a positive pole, so that A $\delta$  fibers can be selectively stimulated. However, in the field, even when the electrical polarity is inverted, the inversion exerts no effect or in-

fluence on nerve stimulation from the skin surface which is used in a measurement of the somatosensory evoked potential SEP (see Fig. 9).

**[0006]** Patent Reference 2 discloses a related-art apparatus which automatically measures in an electrophysiologic or quantitative manner the electrical current perceptible threshold and the algesthetic tolerant threshold. In the related-art apparatus, stimulation is applied by using a sine wave, and C fibers, A $\delta$  fibers, and A $\beta$  fibers are most responsive to stimulation of frequencies of 5 Hz, 250 Hz, and 2,000 Hz, respectively. Patent Reference 2 does not provide a technique in which C fibers, A $\delta$  fibers, and A $\beta$  fibers can be independently stimulated. In the related-art apparatus, stimulation due to a sine wave is required. Therefore, the apparatus is complicated in structure for producing and controlling stimulation, as compared with the case where stimulation is applied by a pulse wave which is typified by a square wave.

**[0007]** The technique disclosed in Patent Reference 2 uses a surface electrode, and hence the stimulation intensity to be applied is larger than the case where an electrode is inserted into the skin. In stimulation of small fibers such as C fibers, namely, there is a large possibility that also other nerve fibers such as the tactile sense are stimulated. Therefore, it is considered that selective stimulation of only C fibers is difficult.

**[0008]** Patent Reference 3 discloses a related-art technique in which specific tactile sensory receptors are selectively stimulated by using a surface electrode and without performing stimulation on the pain sense. This technique is effective in stimulating the tactile sense. Since the surface electrode is used, however, the stimulation intensity is as large as about 2 mA. Furthermore, A $\delta$  fibers and C fibers which relate to the pain sense are small fibers, and hence stimulation is hardly performed. In the related-art technique disclosed in Patent Reference 3, therefore, it is impossible to selectively stimulate A $\delta$  fibers and C fibers. The related-art technique disclosed in Patent Reference 3 has a further problem in that a complex process such as a weighted change is required in selective stimulation of receptors.

**[0009]** In electrical stimulation, excitation is more easily caused in the sequence of A $\beta$  fibers, A $\delta$  fibers, and C fibers. Namely, electrical stimulation is more easily performed on larger medullated fibers having an axial fiber, and excitation due to electrical stimulation most hardly occurs in C fibers which are small fibers, and which are nonmedullated fibers. Therefore, stimulation in which only C fibers are selectively stimulated without stimulating other fibers is very difficult.

[Patent Reference 1] JP-T-2006-59430

[Patent Reference 2] U.S. Patent No. 5,806,522

[Patent Reference 3] Japanese Patent No. 3,543,097

## SUMMARY

**[0010]** It is therefore an object of the invention to provide a simple pain sensory nerve stimulation apparatus which can accurately stimulate only C fibers by electrical stimulation with a very high probability and irrespective of the skill of the operator and to provide a pain sensory nerve stimulation apparatus which can independently stimulate C fibers in an adequate manner according to individual differences.

**[0011]** In order to achieve the object, according to the invention, there is provided a pain sensory nerve stimulation apparatus comprising: an electrode portion including: a first electrode, a tip end of which is adapted to be inserted into a skin; and at least one second electrode which is disposed in a circumference of the first electrode without being electrically conductive with the first electrode, and which is adapted to be in contact with a skin; and a stimulation signal supplying unit, supplying a bipolar stimulation signal between the first electrode and the second electrode, the bipolar stimulation signal including a first waveform signal and a second waveform, the first waveform which is convex in a negative direction in the first electrode, the second waveform signal which is convex in a positive direction in the first electrode.

**[0012]** The pain sensory nerve stimulation apparatus may further include: a rising/falling controlling unit, changing at least one of a rising time and a falling time of each of the first and second waveform signals.

**[0013]** At least one of rising and falling of each of the first and second waveform signals may be changed so as to have a rectilinear inclined shape.

**[0014]** At least one of rising and falling of each of the first and second waveform signals may be changed so as to have an exponential shape.

**[0015]** The pain sensory nerve stimulation apparatus may further include: a stimulation intensity controlling unit, changing at least one of a voltage and a current of each of the first and second waveform signals.

**[0016]** The pain sensory nerve stimulation apparatus may further include: a waveform controlling unit, changing at least one of a waveform duration, waveform interval, and waveform number of each of the first and second waveform signals.

**[0017]** In the bipolar stimulation signal, the second waveform signal may be supplied after the first waveform signal is supplied, and the first and second waveform signals may be connected to each other.

**[0018]** A peak value of the first waveform signal may be different from a peak value of the second waveform signal.

**[0019]** A peak value of the second waveform signal may be higher than a peak value of the first waveform signal.

**[0020]** The bipolar stimulation signal may have a waveform duration of 0.1 to 100 ms.

**[0021]** A peak value of the second waveform signal may be five times or more a peak value of the first wave-

form signal.

**[0022]** Rising and falling times of the first waveform signal may be equal to rising and falling times of the second waveform signal.

**[0023]** The second electrode may be annularly disposed in the circumference of the first electrode.

**[0024]** The pain sensory nerve stimulation apparatus may include a plurality of the electrode portion.

**[0025]** The stimulation signal supplying unit may be adapted to successively supply a plurality of times the bipolar stimulation signal.

## BRIEF DESCRIPTION OF THE DRAWINGS

**[0026]**

Fig. 1 is a block diagram showing the configuration of an embodiment of the pain sensory nerve stimulation apparatus of the invention.

Fig. 2A is a sectional view showing the configuration of electrodes used in the embodiment of the pain sensory nerve stimulation apparatus of the invention.

Fig. 2B is a perspective view showing an example of the electrodes used in the embodiment of the pain sensory nerve stimulation apparatus of the invention.

Fig. 3 is a view showing waveforms of a stimulation signal which is supplied in the embodiment of the pain sensory nerve stimulation apparatus of the invention.

Fig. 4 is a view showing the stimulation signal shown in Fig. 3 with reducing the time scale.

Fig. 5 is a view illustrating first and second waveform signals constituting the stimulation signal which is supplied in the embodiment of the pain sensory nerve stimulation apparatus of the invention.

Fig. 6 is a view illustrating various waveforms of the first and second waveform signals constituting the stimulation signal which is supplied in the embodiment of the pain sensory nerve stimulation apparatus of the invention.

Fig. 7 is a view showing waveforms of stimulation signals which are supplied in the embodiment of the pain sensory nerve stimulation apparatus of the invention, and in which the rising and falling times are made different.

Fig. 8 is a view showing waveforms of stimulation signals which are supplied in the embodiment of the pain sensory nerve stimulation apparatus of the invention, and in which the peak values are made different.

Fig. 9 is a view showing an arrangement of electrodes with respect to a living body in a measurement of the somatosensory evoked potential SEP.

## DETAILED DESCRIPTION OF EMBODIMENTS

**[0027]** Hereinafter, the pain sensory nerve stimulation apparatus of the invention and examples of a method of using the apparatus will be described with reference to the accompanying drawings. In the pain sensory nerve stimulation apparatus, as shown in Fig. 1, a current/voltage controlling portion 21, a power supplying portion 22, a displaying portion 23, and an operating portion 24 are connected to a signal generation body unit 10. A polarity switching portion 25 is connected to the current/voltage controlling portion 21, and an epidermal stimulation electrode portion 30 is connected to the polarity switching portion 25.

**[0028]** The epidermal stimulation electrode portion 30 is structured in a substantially same manner as the electrode disclosed in Patent Reference 1. Fig. 2A is a sectional view of the portion. The epidermal stimulation electrode portion 30 includes: a needle electrode 31 functioning as a first electrode in which the tip end has a shape that allows the tip end to be slightly inserted into the skin (for example, from the skin surface to the papilla); and a contact electrode 32 functioning as a second electrode which is to be used while being in contact with the skin. As seen from Fig. 2, the needle electrode 31 is projected with respect to the contact electrode 32. The tip end of the needle electrode 31 is not always necessary to be pointed, and may have a spherical or rod-like shape. The contact electrode 32 may have a cylindrical shape which surrounds the needle electrode 31 while being centered at the needle electrode 31, or alternatively a plurality of contact electrodes 32 may be cylindrically placed so as to be centered at the needle electrode 31. The contact electrode has an inner diameter of, for example, 1 mm. As shown in Fig. 2B, a part of the contact electrode 32 may have a sharp shape which enables the part to be slightly inserted into the skin.

**[0029]** A spacer 33 configured by an insulating material may be embedded in the gap between the contact electrode 32 and the needle electrode 31. An external fitting portion 34 which has a columnar shape using the contact electrode 32 as a core, and which is formed by an insulating material is disposed in the circumference of the contact electrode 32.

**[0030]** The signal generation body unit 10 is configured by an analog/digital microprocessor, and includes a stimulation signal supplying unit 11 which generates and supplies a stimulation signal, a rising/falling controlling unit 12, and a waveform controlling unit 13. The stimulation signal supplying unit 11 supplies a bipolar stimulation signal formed by a combination of a first waveform signal P1 which is convex in the negative direction in the needle electrode 31, and a second waveform signal P2 which is convex in the positive direction in the needle electrode 31, between the needle electrode 31 and the contact electrode 32. In the embodiment, the waveforms of the signals are configured so that the second waveform signal P2 has a peak value different from that of the first

waveform signal P1. Specifically, for example, the bipolar stimulation signal has the waveform shown in an enlarged view of Fig. 3.

**[0031]** As shown in Fig. 4, the stimulation signal supplying unit 11 can successively supply the bipolar stimulation signal a plurality of times (for example, 100 times). When the stimulation signal is decomposed, as shown in Fig. 5, the signal is configured by combining a sawtooth wave which is the first waveform signal P1, with another sawtooth wave which is the second waveform signal P2. The bipolar stimulation signal is formed as a pulse-like stimulation signal by alternately successively (without no interval between the waveform signals) arranging the first waveform signal P1 and the second waveform signal P2.

**[0032]** In the stimulation signal supplied from the stimulation signal supplying unit 11, preferably, the peak value of the first waveform signal P1 is different from that of the second waveform signal P2. As far as the convex directions of the waveform signals are opposite to each other, the stimulation signal may be configured by any of: a waveform signal in which inclined rising and falling portions are linear as shown in column a of Fig. 6; that in which the portions are exponential as shown in column b; and that in which the portions are gently upward convex (a parabolic shape, or the like). Alternatively, the stimulation signal may be a usual pulse signal.

**[0033]** In the case where the first waveform signal P1 and the second waveform signal P2 are combined with each other, waveforms which are convex in the same direction may be continued five times at the maximum, or a combination in which waveforms of the first waveform signal P1 and those of the second waveform signal P2 are not regularly arranged in the same number may be used. Intervals (flat portions) may be disposed between waveforms of the first waveform signal P1 and those of the second waveform signal P2.

**[0034]** The rising/falling controlling unit 12 changes at least one of the rising and falling times of waveform signals of the stimulation signal supplied from the stimulation signal supplying unit 11. The operating portion 24 constituting an instruction inputting portion may be configured by dials, buttons, a keyboard, a touch panel, or the like, and includes a rising/falling time instructing unit. The rising/falling time instructing unit can give an instruction input for changing the stimulation signal to a signal configured by a combination of waveform signals having desired rising and falling times, to the rising/falling controlling unit 12. Furthermore, the rising/falling controlling unit 12 can select either of a rectilinear mode where the rise and fall of each waveform signal have rectilinearly rising and falling shapes, and an exponential mode where the rise and fall of each waveform signal have exponentially rising and falling shapes, so that the stimulation signal can be produced in which waveform signals having one shape that is selected from a plurality of shapes such as shown in Fig. 6 described above are combined with each other while setting upward convex and downward convex.

**[0035]** In the instruction input from the rising/falling time instructing unit, the rising time and the falling time can be designated. As the rising time and the falling time, for example, a desired value can be selected from 0 ms to about 15 ms. Fig. 7 shows three kinds of second waveform signals P21 to P23 which are in the rectilinear mode, in which their falling times are 1 ms, 2 ms, and 3 ms, respectively, and which are convex in the positive direction.

**[0036]** The waveform controlling unit 13 disposed in the signal generation body unit 10 changes the waveform duration, waveform interval, and waveform number of the stimulation signal supplied from the stimulation signal supplying unit 11. The operating portion 24 includes a waveform instructing unit. The waveform instructing unit can give instructions for causing the waveform controlling unit 13 to change the stimulation signal to a signal configured by waveforms of a desired waveform duration, waveform interval, and waveform number.

**[0037]** The waveform duration, the waveform interval, and the waveform number are selected. The waveform duration can be selected from 0.5 to 30 ms in increments of, for example, 0.1 ms, the waveform interval can be selected from 1 to 100 ms in increments of, for example, 1 ms, and the waveform number can be selected in increments of, for example, 1.

**[0038]** The current/voltage controlling portion 21 connected to the signal generation body unit 10 is a stimulation intensity controlling unit for changing at least one of the voltage and current of each of the first waveform signal P1 and second waveform signal P2 supplied from the stimulation signal supplying unit 11. The voltage and the current correspond to the peak value of the first waveform signal P1 or the second waveform signal P2. The operating portion 24 includes a stimulation intensity instructing unit. The stimulation intensity instructing unit can give instructions for causing the current/voltage controlling portion 21 functioning as the stimulation intensity controlling unit, to change the peak values of the first waveform signal P1 and the second waveform signal P2 to desired currents or voltages.

**[0039]** In the case of the current control, for example, the current/voltage controlling portion is configured so that the current can be raised from 0.0 mA at 0.01 mA intervals to a predetermined value (also can be lowered from a desired value). After the needle electrode 31 and the contact electrode 32 are attached, the inter-electrode impedance is seemed to be constant. Therefore, the portion may be configured so that the voltage can be raised from a predetermined value (for example, 0 V) at 0.2 V intervals to another predetermined value (also can be lowered from a desired value). Alternatively, a configuration in which the peak value of the first waveform signal P1 can be input, and a multiplication factor (actually, a fraction) of the peak value of the second waveform signal P2 with respect to the first waveform signal P1 can be input may be employed, or by contrast that in which the peak value of the second waveform signal P2 can be

input, and a multiplication factor of the peak value of the first waveform signal P1 with respect to the second waveform signal P2 can be input may be employed. The example of Fig. 8 shows waveform signals P2(a), P2(b), P2(b) in which the peak values of the second waveform signals P2 are set respectively to four, eight, and ten times in the positive side with respect to the first waveform signal P1 that is 0.1 mA in the negative side.

**[0040]** The polarity switching portion 25 connected to the current/voltage controlling portion 21 functions as an electrical polarity converting unit for converting between the electrical polarity of the needle electrode 31 and that of the contact electrode 32. The operating portion 24 includes a polarity conversion instructing unit. The polarity conversion instructing unit can give instructions for causing the polarity switching portion 25 functioning as the electrical polarity converting unit to convert the electrical polarity. According to the configuration, the electrical polarity of the needle electrode 31 may be set as the positive pole, and that of the contact electrode 32 may be set as the negative pole. When the stimulation signal of Fig. 3 or 4 is supplied in this state, a bipolar stimulation signal configured by a combination of a first inverted waveform signal in which, in the needle electrode 31, the first waveform signal P1 is convex in the negative direction, and a second inverted waveform signal in which, in the needle electrode 31, the second waveform signal P2 is convex in the positive direction is supplied. By contrast, the electrical polarity of the needle electrode 31 may be set as the negative pole, and that of the contact electrode 32 may be set as the positive pole. In this case, when the stimulation signal of Fig. 3 or 4 is supplied, a bipolar stimulation signal configured by a combination of a first inverted waveform signal in which, in the needle electrode 31, the first waveform signal P1 is convex in the positive direction, and a second inverted waveform signal in which, in the needle electrode 31, the second waveform signal P2 is convex in the negative direction is supplied.

**[0041]** Character information produced by the generation body unit 10, such as the present stimulation intensity (mA), the rising times, falling times, waveform durations, waveform intervals, and waveform numbers of the waveform signals, and the polarities of the electrodes can be displayed on the displaying portion 23.

**[0042]** The thus configured pain sensory nerve stimulation apparatus is used in the following manner. First, the epidermal stimulation electrode portion 30 is contacted with the skin in the test area of the subject, and fixed thereto so that the needle electrode 31 is inserted into the skin. At this time, the needle electrode 31 is inserted into the skin by a depth of about 0.01 to 0.3 mm. Next, the operating portion 24 is operated so as to supply the stimulation signal of Fig. 3 or 4. In the first waveform signal P1, then, the needle electrode 31 is in the negative side, so that the cathode stimulation is performed, and, in the second waveform signal P2, the needle electrode 31 is in the positive side, so that the anode stimulation is performed.

**[0043]** The operating portion 24 is further operated so as to cause: the rising/falling time instructing unit to give an instruction input for causing the rising/falling controlling unit 12 to change the stimulation signal to have desired rising and falling times; the waveform instructing unit to give instructions for causing the waveform controlling unit 13 to change the stimulation signal to have a desired waveform duration, waveform interval, and waveform number; and the stimulation intensity instructing unit to give instructions for causing the current/voltage controlling portion 21 functioning as the stimulation intensity controlling unit, to change the stimulation signal to have a desired current or voltage. From the display on the displaying portion 23, it is checked that desired settings are performed by the operating portion 24, and an operation of starting stimulation is then performed.

**[0044]** As described above, the stimulation signal such as shown Fig. 3 or 4 is applied between the needle electrode 31 and the contact electrode 32 to perform stimulation. In this state, the operating portion 24 is operated so as to gradually increase the current value (or the voltage value) until the subject feels pain. Alternatively, measurement may be conducted while the rising and falling times are changed, or while the waveform duration, waveform interval, and waveform number are changed. If the subject has a nervous disorder, this can be determined from a phenomenon that the subject does not feel pain, or that, even the subject feels pain, stimulation of higher intensity is required. Moreover, the epidermal stimulation electrode portion 30 is contacted with the skin in another (or the identical) test area of the subject, so that differences depending on the stimulation position, a difference between right and left body portions, and the like can be checked. When the operating portion 24 is operated so as to convert the electrical polarities of the needle electrode 31 and the contact electrode 32 and then measurements are conducted in the same manner as described above, also knowing of progression of and adequate control of a diabetic nervous disorder can be checked.

**[0045]** In this field, it is said that a C fiber nociceptive receptor relates to steady or burning pain which is typified by inflammation, and an A $\delta$  nociceptive receptor controls sharp pain. When the subject was stimulated by the stimulation apparatus of the invention, the number of the cases where the subject felt steady or burning pain irrespective of the skill of the operator was increased as compared with the related art. This means that, instead of A $\delta$  fibers, C fibers can be accurately stimulated.

**[0046]** In the embodiment, in the case where the peak value of the second waveform signal is five times or more that of the first waveform signal, remarkable results were obtained. In the case where the bipolar stimulation signal was successively supplied a plurality of times, remarkable results were obtained.

**[0047]** In the above-described embodiment, it is a matter of course that a configuration in which a plurality of epidermal stimulation electrode portions 30 are disposed

may be employed and used.

**[0048]** According to an aspect of the invention, only C fibers having the thinnest fiber diameter were stimulated by supplying the bipolar stimulation signal formed by the combination of the first waveform signal which is convex in the negative direction in the first electrode, and the second waveform signal which is convex in the positive direction in the first electrode. The first electrode has a needle-like shape, and hence the area contacting with a living body is very smaller than that of the second electrode. Therefore, there is a possibility that C fibers which are thinner than A $\delta$  fibers cannot be adequately excited. This is caused mainly by the fact that smaller fibers have a lower threshold with respect to electrical stimulation. By contrast, C fibers have possibly available physical properties such as that the distribution density is higher than A $\delta$  fibers, that the fibers run perpendicularly to the skin surface, and that the fibers extend to the surface part as compared with ends of mechanoreceptors. According to an aspect of the invention, it was noted that the number of subjects answering that a sense of burning pain which is typified by inflammation is caused is very larger as compared with a case of any of related-art techniques including the technique disclosed in JP-A-2010-088802 which was previously filed by the inventors of the present application, and only C fibers can be stimulated without substantially affecting other nerve fibers. This means that the apparatus of the invention can stimulate only C fibers with a high probability and irrespective of the skill of the operator.

**[0049]** According to an aspect of the invention, the apparatus includes the rising/falling controlling unit for changing at least one of rising and falling times of each of the waveform signal. While at least one of rising and falling times of each of the waveform signal is changed, therefore, the supply of the stimulation signal in which only C fibers having the smallest diameter are stimulated without substantially affecting other nerve fibers can be performed.

**[0050]** According to an aspect of the invention, the apparatus includes the stimulation intensity controlling unit for changing at least one of the voltage and current of the stimulation signal supplied from the stimulation signal supplying unit. Therefore, also A $\delta$  fibers and A $\beta$  fibers which are larger nerve fibers can be stimulated by changing the stimulation intensity.

**[0051]** According to an aspect of the invention, when the stimulation intensity is changed, respective nerve fibers can be stimulated in the sequence which is opposite to the excitability sequence (A $\beta$ , A $\delta$ , and C) in the usual electrical stimulation. Particularly, C fibers can be selectively stimulated at a weak stimulation intensity.

**[0052]** According to an aspect of the invention, the apparatus includes the waveform controlling unit for changing the waveform duration, waveform interval, and waveform number of the stimulation signal supplied from the stimulation signal supplying unit. Therefore, a measurement which absorbs individual differences can be per-

formed while searching the waveform duration, waveform interval, and waveform number at which stimulation of C fibers only is enabled.

**[0053]** Even when stimulation is performed on a part of nerve fibers, effects and reactions caused by stimulations are identical with one another. When a plurality of electrode portions are used or the bipolar stimulation signal is successively supplied a plurality of times, therefore, only C fibers can be stimulated with a higher probability and irrespective of the skill of the operator.

### Claims

1. A pain sensory nerve stimulation apparatus comprising:  
an electrode portion (30) including:

a first electrode (31), a tip end of which is adapted to be inserted into a skin; and  
at least one second electrode (32) which is disposed in a circumference of the first electrode (31) without being electrically conductive with the first electrode (31), and which is adapted to be in contact with a skin;

a stimulation signal supplying unit (10), supplying a bipolar stimulation signal between the first electrode (31) and the second electrode (32), the bipolar stimulation signal including a first waveform signal and a second waveform signal, the first waveform signal which is convex in a negative direction in the first electrode (cathode simulation);

the second waveform signal which is convex in a positive direction in the first electrode (cathode simulation); and

a stimulation intensity controlling unit, configured to change at least one of a voltage and a current of each of the first and second waveform signals to change stimulation intensity,

**characterised in that** the apparatus is configured such that C-fibres can be selectively stimulated at a weak stimulation intensity and that by changing the stimulation intensity C fibers, A $\delta$  fibers and A $\beta$  fibers can be stimulated in a sequence which is opposite to an excitability sequence.

2. The pain sensory nerve stimulation apparatus according to claim 1, further comprising:  
a rising/falling controlling unit, changing at least one of a rising time and a falling time of each of the first and second waveform signals.
3. The pain sensory nerve stimulation apparatus according to claim 2, wherein  
at least one of rising and falling of each of the first and second waveform signals is changed so as to

have a rectilinear inclined shape.

4. The pain sensory nerve stimulation apparatus according to claim 2, wherein  
at least one of rising and falling of each of the first and second waveform signals is changed so as to have an exponential shape.
5. The pain sensory nerve stimulation apparatus according to claim 1, further comprising:  
a waveform controlling unit, changing at least one of a waveform duration, waveform interval, and waveform number of each of the first and second waveform signals.
6. The pain sensory nerve stimulation apparatus according to claim 1, wherein  
in the bipolar stimulation signal, the second waveform signal is supplied after the first waveform signal is supplied, and the first and second waveform signals are connected to each other.
7. The pain sensory nerve stimulation apparatus according to claim 1, wherein  
a peak value of the first waveform signal is different from a peak value of the second waveform signal.
8. The pain sensory nerve stimulation apparatus according to claim 1, wherein  
a peak value of the second waveform signal is higher than a peak value of the first waveform signal.
9. The pain sensory nerve stimulation apparatus according to claim 1, wherein  
the bipolar stimulation signal has a waveform duration of 0.1 to 100 ms.
10. The pain sensory nerve stimulation apparatus according to claim 1, wherein  
a peak value of the second waveform signal is five times or more a peak value of the first waveform signal.
11. The pain sensory nerve stimulation apparatus according to claim 1, wherein  
rising and falling times of the first waveform signal are equal to rising and falling times of the second waveform signal.
12. The pain sensory nerve stimulation apparatus according to claim 1, wherein  
the second electrode is annularly disposed in the circumference of the first electrode.
13. The pain sensory nerve stimulation apparatus according to claim 1, comprising a plurality of the electrode portion.

14. The pain sensory nerve stimulation apparatus according to claim 1, wherein the stimulation signal supplying unit is adapted to successively supply a plurality of times the bipolar stimulation signal.

15. The pain sensory nerve stimulation apparatus according to claim 1, wherein, in the bipolar stimulation signal, the second waveform signal is supplied after the first waveform signal is supplied, and when the bipolar stimulation signal is supplied, in the first waveform signal, the first electrode is in the negative side, so that a cathode stimulation is performed, and, in the second waveform signal, the first electrode is in the positive side, so that an anode stimulation is performed.

#### Patentansprüche

1. Gerät zur Stimulation schmerzempfindlicher Nerven, umfassend:  
einen Elektrodenabschnitt (30), der umfasst:

eine erste Elektrode (31), von der ein Spitze-  
nende zum Einführen in eine Haut geeignet ist;  
und

wenigstens eine zweite Elektrode (32), die in einem Umfang der ersten Elektrode (31) angeordnet ist, ohne mit der ersten Elektrode (31) elektrisch leitend zu sein, und die dazu geeignet ist, mit einer Haut in Kontakt zu stehen;

eine Stimulationssignal-Zuführeinheit (10), die ein bipolares Stimulationssignal zwischen der ersten Elektrode (31) und der zweiten Elektrode (32) zuführt, wobei das bipolare Stimulationssignal ein erstes Wellenformsignal und ein zweites Wellenformsignal enthält, wobei das erste Wellenformsignal in der ersten Elektrode in einer negativen Richtung konvex ist (Kathodenstimulation) und das zweite Wellenformsignal in der ersten Elektrode in einer positiven Richtung konvex ist (Anodenstimulation); und

eine Stimulationsintensitäts-Steuereinheit, die dazu eingerichtet ist, eine Spannung und/oder einen Strom des ersten und zweiten Wellenformsignals zu ändern, um die Stimulationsintensität zu ändern,

**dadurch gekennzeichnet, dass** das Gerät derart beschaffen ist, dass C-Fasern selektiv mit einer schwachen Stimulationsintensität stimuliert werden können und dass durch Änderung der Stimulationsintensität C-Fasern, A $\delta$ -Fasern und A $\beta$ -Fasern in einer Sequenz stimuliert werden können, die einer Erregbarkeitssequenz entgegengesetzt ist.

2. Gerät zur Stimulation schmerzempfindlicher Nerven nach Anspruch 1, weiterhin umfassend:  
eine Anstiegs-/Abfalls-Steuereinheit, die eine Anstiegszeit und/oder eine Abfallszeit jedes der ersten und zweiten Wellenformsignale ändert.

3. Gerät zur Stimulation schmerzempfindlicher Nerven nach Anspruch 2, bei dem wenigstens eines der beiden Signale, nämlich das steigende und das fallende Signal der ersten und zweiten Wellenform, so verändert wird, dass es eine geradlinige, geneigte Form hat.

4. Gerät zur Stimulation schmerzempfindlicher Nerven nach Anspruch 2, bei dem wenigstens ein Anstieg oder ein Abfall des ersten und zweiten Wellenformsignals so verändert wird, dass es eine exponentielle Form hat.

5. Gerät zur Stimulation schmerzempfindlicher Nerven nach Anspruch 1, weiterhin umfassend:  
eine Wellenform-Steuereinheit, die die Dauer, das Wellenform-Intervall und/oder die Anzahl der Wellenformen des ersten und des zweiten Wellenformsignals ändert.

6. Gerät zur Stimulation schmerzempfindlicher Nerven nach Anspruch 1, bei dem in dem bipolaren Stimulationssignal das zweite Wellenformsignal nach dem ersten Wellenformsignal zugeführt wird und das erste sowie das zweite Wellenformsignal miteinander verbunden werden.

7. Gerät zur Stimulation schmerzempfindlicher Nerven nach Anspruch 1, bei dem ein Spitzenwert des ersten Wellenformsignals sich von einem Spitzenwert des zweiten Wellenformsignals unterscheidet.

8. Gerät zur Stimulation schmerzempfindlicher Nerven nach Anspruch 1, bei dem ein Spitzenwert des zweiten Wellenformsignals höher ist als ein Spitzenwert des ersten Wellenformsignals.

9. Gerät zur Stimulation schmerzempfindlicher Nerven nach Anspruch 1, bei dem das bipolare Stimulationssignal eine Wellenformdauer von 0,1 bis 100 ms hat.

10. Gerät zur Stimulation schmerzempfindlicher Nerven nach Anspruch 1, bei dem ein Spitzenwert des zweiten Wellenformsignals wenigstens das Fünffache eines Spitzenwertes des ersten Wellenformsignals ist.

11. Gerät zur Stimulation schmerzempfindlicher Nerven nach Anspruch 1, bei dem

die Anstiegs- und Abfallszeiten des ersten Wellenformsignals gleich den Anstiegs- und Abfallszeiten des zweiten Wellenformsignals sind.

12. Gerät zur Stimulation schmerzempfindlicher Nerven nach Anspruch 1, bei dem die zweite Elektrode ringförmig im Umfang der ersten Elektrode angeordnet ist. 5
13. Gerät zur Stimulation schmerzempfindlicher Nerven nach Anspruch 1, umfassend eine Vielzahl des Elektrodenabschnitts. 10
14. Gerät zur Stimulation schmerzempfindlicher Nerven nach Anspruch 1, bei dem die Stimulationssignal-Zuführeinheit so ausgelegt ist, dass sie nacheinander ein Mehrfaches des bipolaren Stimulationssignals zuführt. 15
15. Gerät zur Stimulation schmerzempfindlicher Nerven nach Anspruch 1, bei dem in dem bipolaren Stimulationssignal das zweite Wellenformsignal nach dem ersten Wellenformsignal zugeführt wird und, wenn das bipolare Stimulationssignal zugeführt wird, in dem ersten Wellenformsignal die erste Elektrode auf der negativen Seite ist, so dass eine Kathodenstimulation ausgeführt wird, und sich in dem zweiten Wellenformsignal die erste Elektrode auf der positiven Seite befindet, so dass eine Anodenstimulation ausgeführt wird. 20 25 30

#### Revendications 35

1. Appareil de stimulation du nerf sensoriel de la douleur comprenant :  
une partie électrode (30) comprenant :  
une première électrode (31), dont une extrémité pointue est adaptée pour être insérée dans une peau ; et  
au moins une seconde électrode (32) qui est disposée dans une circonférence de la première électrode (31) sans être électriquement conductrice avec la première électrode (31), et qui est adaptée pour être en contact avec une peau ;  
une unité d'alimentation de signal de stimulation (10), alimentant un signal de stimulation bipolaire entre la première électrode (31) et la seconde électrode (32), le signal de stimulation bipolaire comprenant un premier signal de forme d'onde et un second signal de forme d'onde, le premier signal de forme d'onde qui est convexe dans un sens négatif dans la première électrode (stimulation de cathode), le second signal de forme d'onde qui est convexe dans un 40 45 50 55

sens positif dans la première électrode (stimulation d'anode) ; et

une unité de commande d'intensité de stimulation, configurée pour changer au moins l'un d'une tension et d'un courant de chacun du premier et du second signal de forme d'onde pour changer l'intensité de stimulation, **caractérisé en ce que** l'appareil est configuré de sorte que les fibres C peuvent être sélectivement stimulées à une intensité de stimulation faible et qu'en changeant l'intensité de stimulation des fibres C, les fibres A $\delta$  et les fibres A $\beta$  peuvent être stimulées en une séquence qui est opposée à une séquence d'excitabilité.

2. Appareil de stimulation du nerf sensoriel de la douleur selon la revendication 1, comprenant en outre : une unité de commande de montée/descente, le changement d'au moins l'un d'un temps de montée et d'un temps de descente de chacun du premier et du second signal de forme d'onde.
3. Appareil de stimulation du nerf sensoriel de la douleur selon la revendication 2, au moins l'une de la montée et de la descente de chacun du premier et du second signal de forme d'onde est changée afin d'avoir une forme inclinée rectiligne.
4. Appareil de stimulation du nerf sensoriel de la douleur selon la revendication 2, au moins l'une de la montée et de la descente de chacun du premier et du second signal de forme d'onde est changée afin d'avoir une forme exponentielle.
5. Appareil de stimulation du nerf sensoriel de la douleur selon la revendication 1, comprenant en outre : une unité de commande de forme d'onde, changeant au moins l'une d'une durée de forme d'onde, d'un intervalle de forme d'onde, et d'un nombre de forme d'onde de chacun du premier et du second signal de forme d'onde.
6. Appareil de stimulation du nerf sensoriel de la douleur selon la revendication 1, dans le signal de stimulation bipolaire, le second signal de forme d'onde étant alimenté après que le premier signal de forme d'onde soit alimenté, et le premier et le second signal de forme d'onde sont reliés l'un à l'autre.
7. Appareil de stimulation du nerf sensoriel de la douleur selon la revendication 1, une valeur pic du premier signal de forme d'onde étant différente d'une valeur pic du second signal de forme d'onde.

8. Appareil de stimulation du nerf sensoriel de la douleur selon la revendication 1, une valeur pic du second signal de forme d'onde est supérieure à une valeur pic du premier signal de forme d'onde. 5
9. Appareil de stimulation du nerf sensoriel de la douleur selon la revendication 1, le signal de stimulation bipolaire ayant une durée de forme d'onde de 0,1 à 100 ms. 10
10. Appareil de stimulation du nerf sensoriel de la douleur selon la revendication 1, une valeur pic du second signal de forme d'onde est cinq fois ou plus une valeur pic du premier signal de forme d'onde. 15
11. Appareil de stimulation du nerf sensoriel de la douleur selon la revendication 1, les temps de montée et de descente du premier signal de forme d'onde étant égaux aux temps de montée et de descente du second signal de forme d'onde. 20
12. Appareil de stimulation du nerf sensoriel de la douleur selon la revendication 1, la seconde électrode étant disposée de manière annulaire dans la circonférence de la première électrode. 25
13. Appareil de stimulation du nerf sensoriel de la douleur selon la revendication 1, comprenant une pluralité de la partie électrode. 30
14. Appareil de stimulation du nerf sensoriel de la douleur selon la revendication 1, l'unité d'alimentation de signal de stimulation étant adaptée pour alimenter successivement une pluralité de fois le signal de stimulation bipolaire. 35
15. Appareil de stimulation du nerf sensoriel de la douleur selon la revendication 1, dans le signal de stimulation bipolaire, le second signal de forme d'onde étant alimenté après que le premier signal de forme d'onde soit alimenté, et lorsque le signal de stimulation bipolaire est alimenté, 40  
dans le premier signal de forme d'onde, la première électrode se trouve du côté négatif, de sorte qu'une stimulation de cathode est effectuée, et, 45  
dans le second signal de forme d'onde, la première électrode se trouve du côté positif, de sorte qu'une stimulation d'anode est effectuée. 50

55

FIG. 1

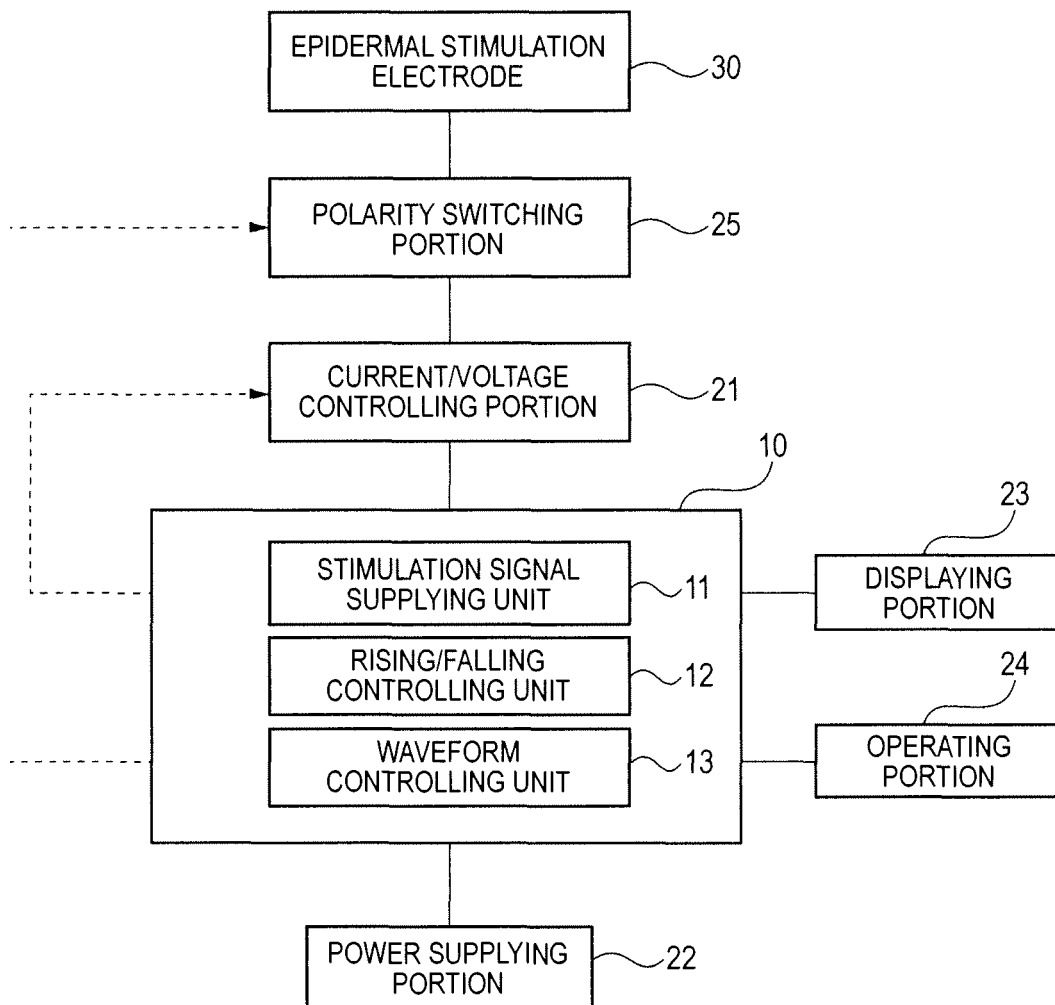

FIG. 2A

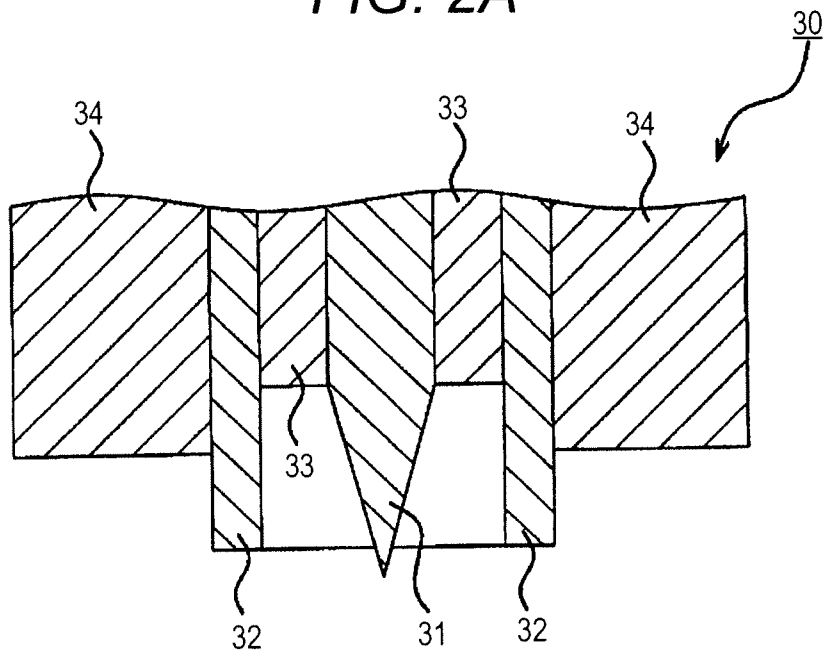

FIG. 2B

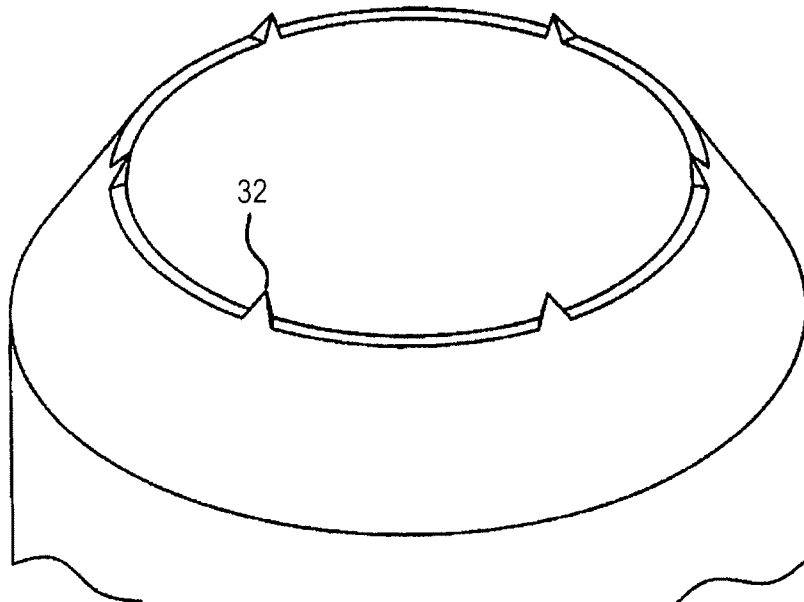

FIG. 3

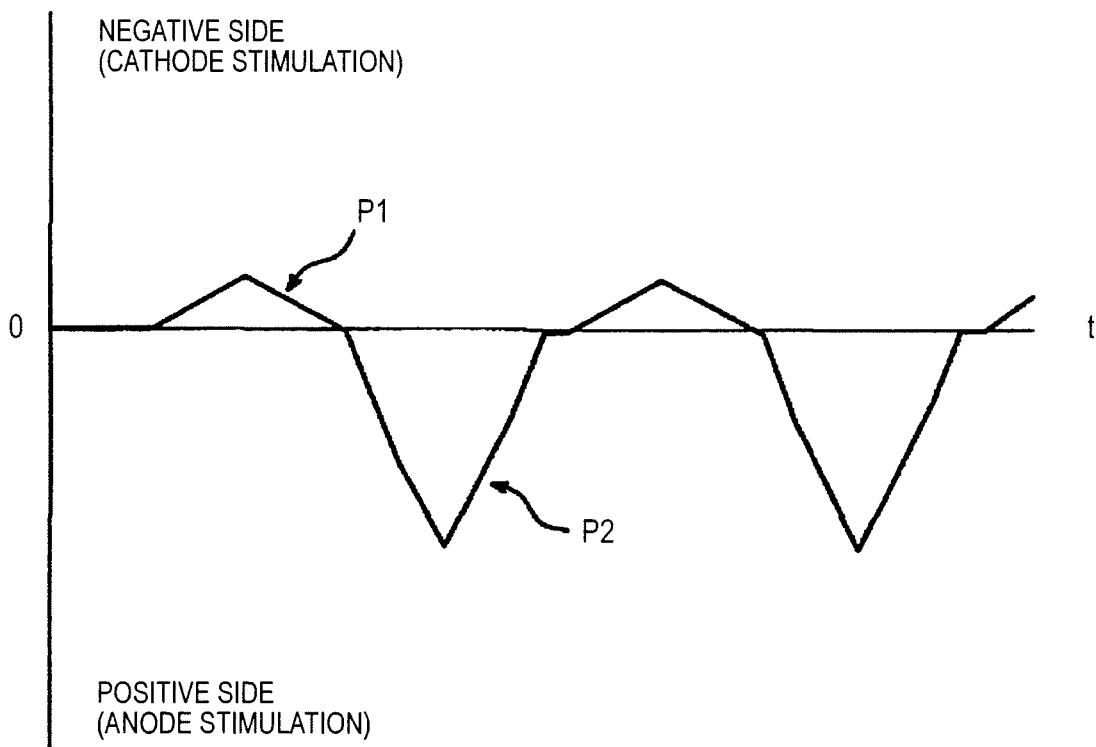

FIG. 4

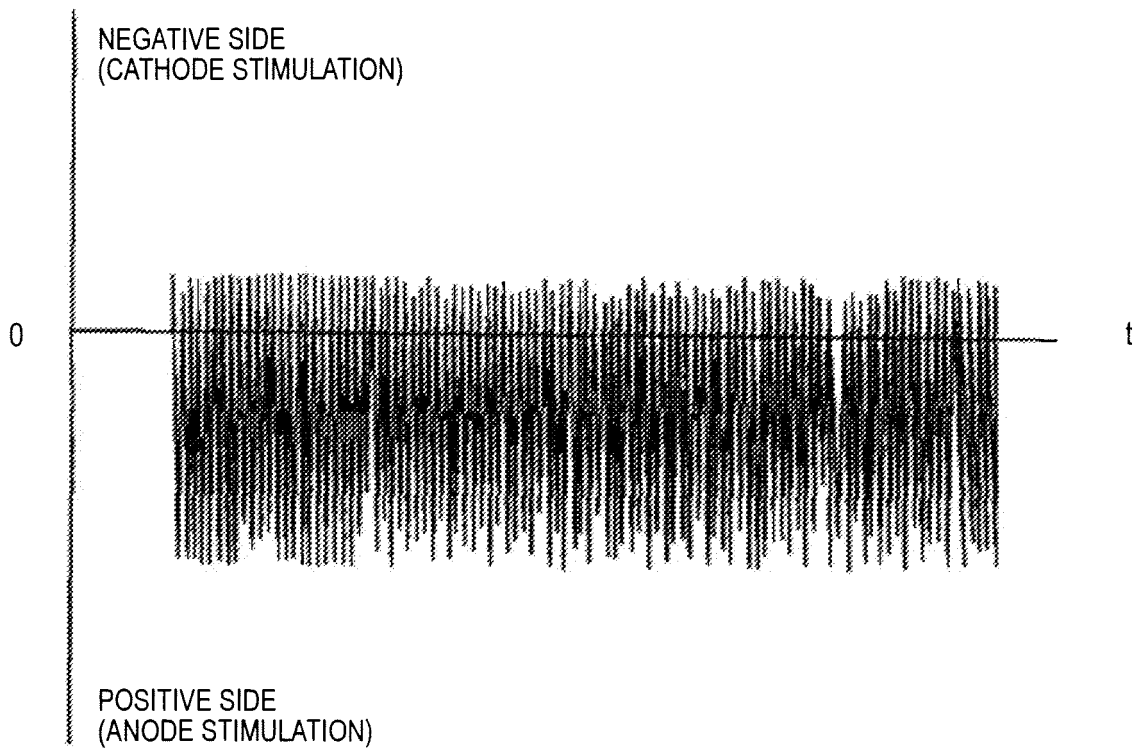
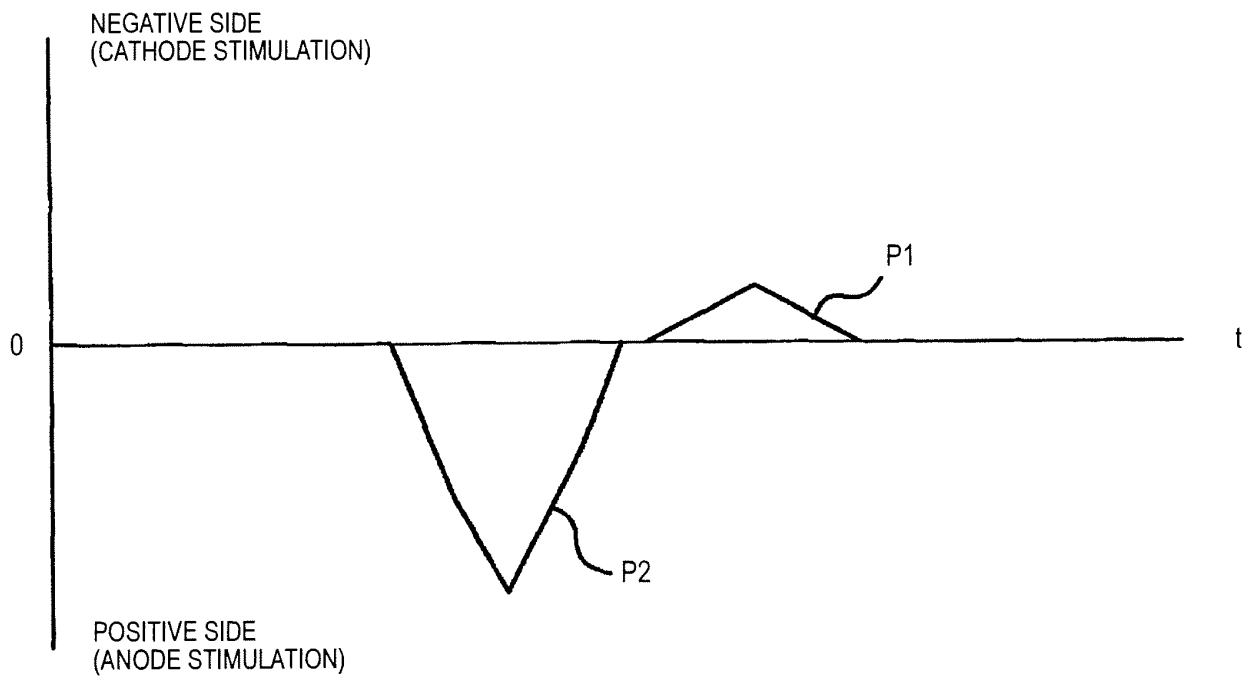
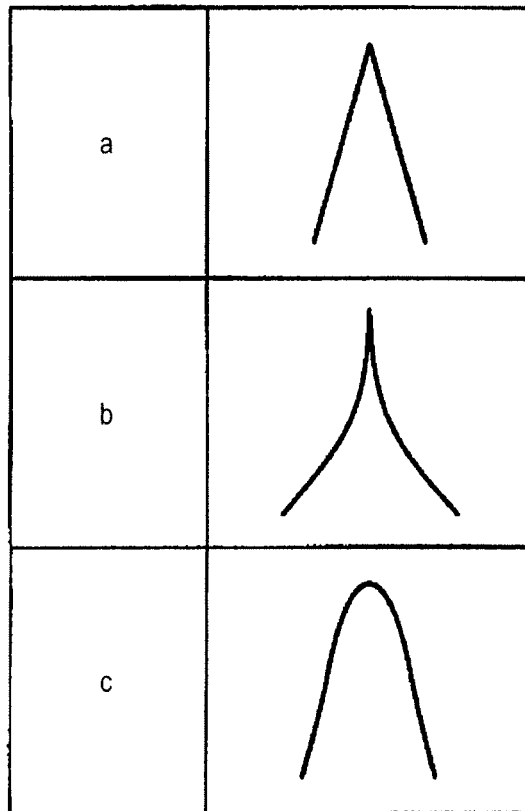

FIG. 5



*FIG. 6*



*FIG. 7*

ABSCISSA: 1 ms

ORDINATE: 0.1 mA

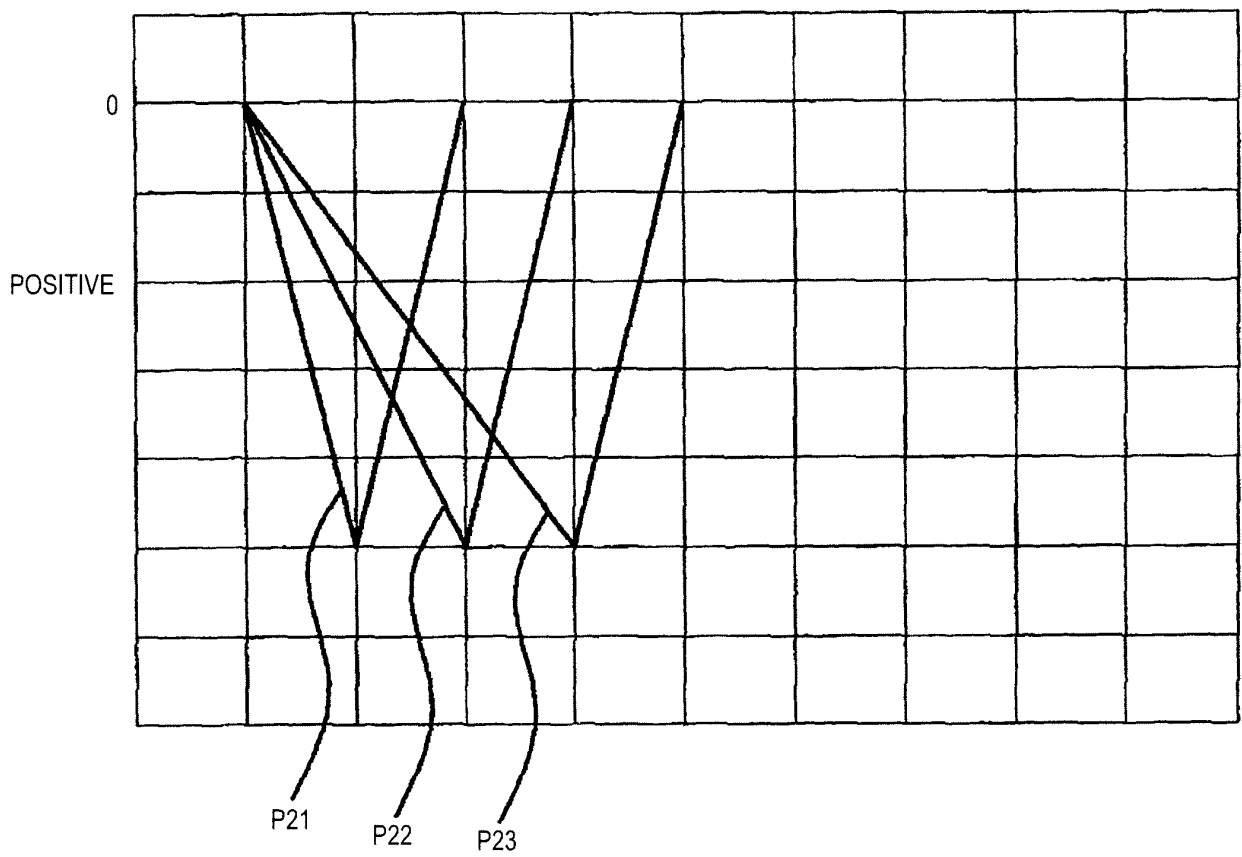

FIG. 8

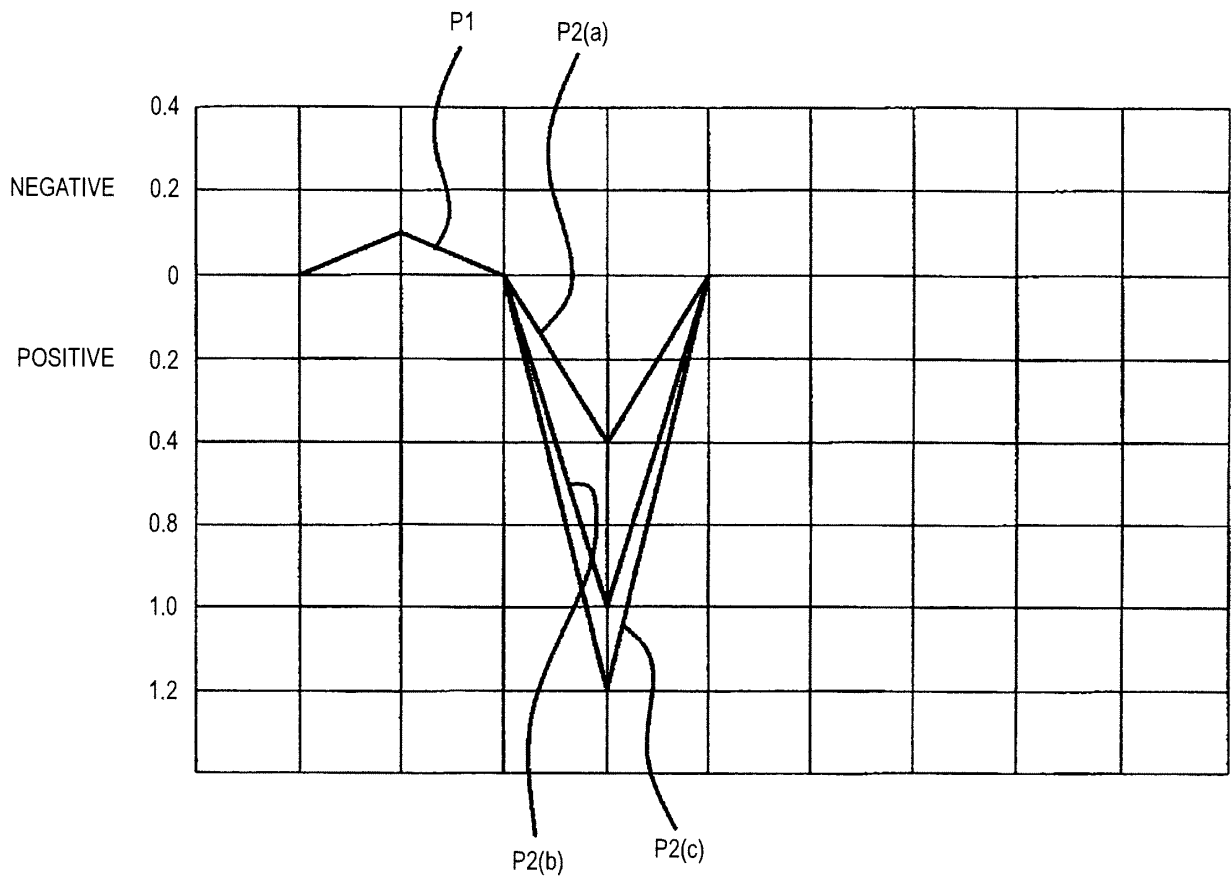
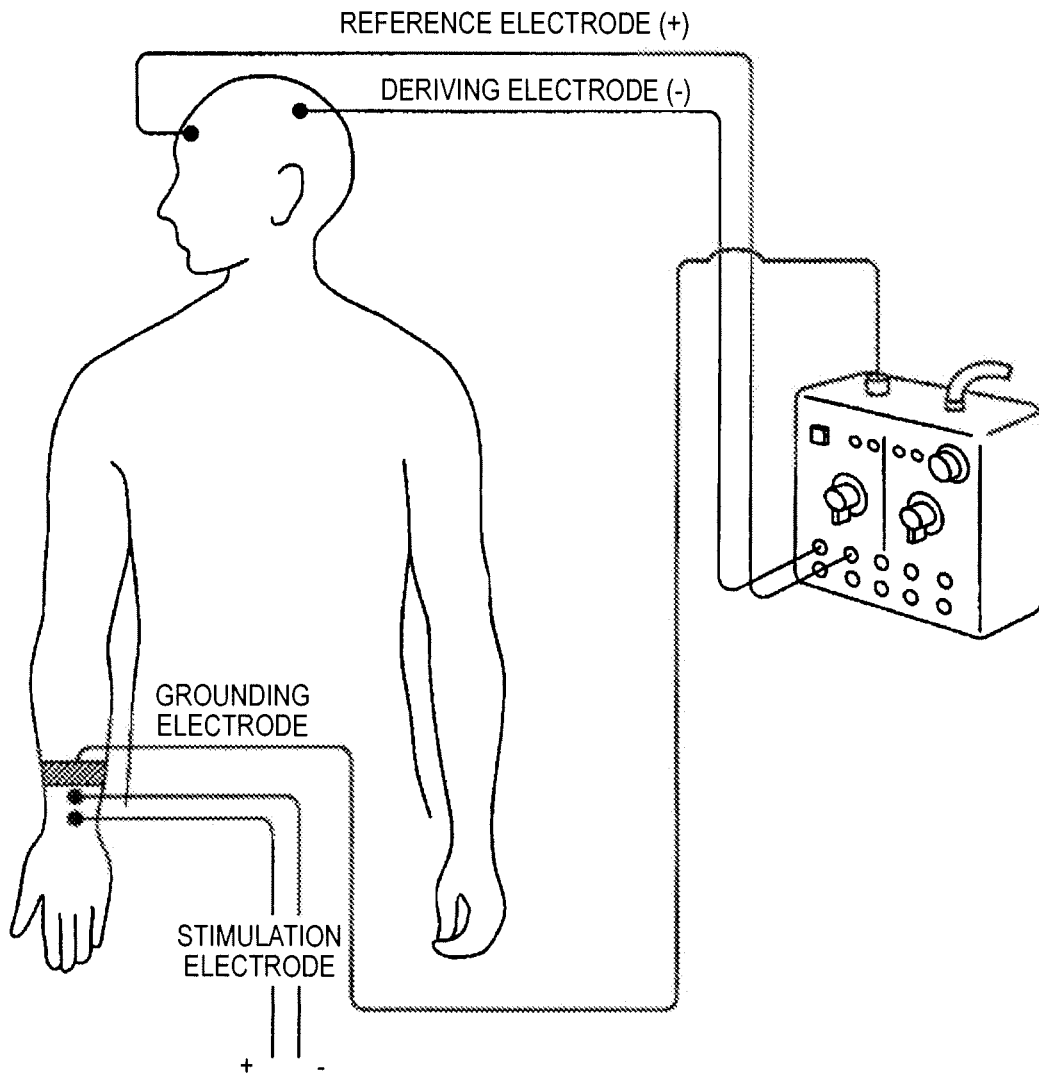

FIG. 9



**REFERENCES CITED IN THE DESCRIPTION**

*This list of references cited by the applicant is for the reader's convenience only. It does not form part of the European patent document. Even though great care has been taken in compiling the references, errors or omissions cannot be excluded and the EPO disclaims all liability in this regard.*

**Patent documents cited in the description**

- JP 2006059430 T [0009]
- US 5806522 A [0009]
- JP 3543097 B [0009]
- JP 2010088802 A [0048]

专利名称(译)	疼痛传感器神经刺激装置		
公开(公告)号	<a href="#">EP2353640B1</a>	公开(公告)日	2020-04-08
申请号	EP2011153842	申请日	2011-02-09
[标]申请(专利权)人(译)	日本光电工业株式会社		
申请(专利权)人(译)	日本光电公司 自然科学科学大学间试验研究院国家机构		
当前申请(专利权)人(译)	日本光电公司 自然科学科学大学间试验研究院国家机构		
[标]发明人	INUI KOJI TAKESHIMA YASUYUKI MOTOGI JUN ONO YOSHINOBU KOJIMA TAKESHI USHIJIMA RYOSUKE NAKAICHI KATSUMI SHIBUYA KAZUWA		
发明人	INUI, KOJI TAKESHIMA, YASUYUKI MOTOGI, JUN ONO, YOSHINOBU KOJIMA, TAKESHI USHIJIMA, RYOSUKE NAKAICHI, KATSUMI SHIBUYA, KAZUWA		
IPC分类号	A61N1/36 A61B5/00 A61N1/04		
CPC分类号	A61B5/4824 A61N1/0456 A61N1/0472 A61N1/36021		
优先权	2010026278 2010-02-09 JP		
其他公开文献	EP2353640A3 EP2353640A2		
外部链接	<a href="#">Espacenet</a>		

#### 摘要(译)

一种疼痛感觉神经刺激设备，包括：电极部分，其包括：第一电极，其顶端适于插入皮肤中；至少一个第二电极，其布置在第一电极的周围而不与第一电极导电，并且适于与皮肤接触；刺激信号提供单元，在第一电极和第二电极之间提供双极性刺激信号，该双极性刺激信号包括第一波形信号和第二波形，第一波形在第一电极中向负方向凸出，在第一电极中在正方向上凸出的第二波形信号。

FIG. 1

