



(11) **EP 2 285 271 B1**

(12) **EUROPEAN PATENT SPECIFICATION**

(45) Date of publication and mention of the grant of the patent:
07.09.2011 Bulletin 2011/36

(21) Application number: **09766237.3**

(22) Date of filing: **09.06.2009**

(51) Int Cl.:
A61B 5/00 (2006.01)

(86) International application number:
PCT/IB2009/052435

(87) International publication number:
WO 2009/153700 (23.12.2009 Gazette 2009/52)

(54) **MONITORING A VITAL PARAMETER OF A PATIENT WITH "IN-SITU" MODULATION SCHEME TO AVOID INTERFERENCE**

ÜBERWACHUNG EINES VITALPARAMETERS EINES PATIENTEN MIT EINEM IN-SITU-MODULATIONSSCHEMA ZUR VERMEIDUNG VON INTERFERENZEN

SURVEILLANCE D'UN PARAMÈTRE VITAL D'UN PATIENT AVEC UN SCHÉMA DE MODULATION « IN SITU » POUR ÉVITER UNE INTERFÉRENCE

(84) Designated Contracting States:
AT BE BG CH CY CZ DE DK EE ES FI FR GB GR HR HU IE IS IT LI LT LU LV MC MK MT NL NO PL PT RO SE SI SK TR

(30) Priority: **16.06.2008 EP 08104427**

(43) Date of publication of application:
23.02.2011 Bulletin 2011/08

(73) Proprietor: **Koninklijke Philips Electronics N.V. 5621 BA Eindhoven (NL)**

(72) Inventors:
• **VEEN, Jeroen**
NL-5656 AE Eindhoven (NL)
• **JANSEN, Theodorus, P., H., G.**
NL-5656 AE Eindhoven (NL)

- **VERBERNE, Henricus, R., M.**
NL-5656 AE Eindhoven (NL)
- **SCHENK, Tim, C., W.**
NL-5656 AE Eindhoven (NL)
- **FERI, Lorenzo**
NL-5656 AE Eindhoven (NL)

(74) Representative: **Van Velzen, Maaïke Mathilde Philips Intellectual Property & Standards P.O. Box 220 5600 AE Eindhoven (NL)**

(56) References cited:
EP-A- 1 655 881 WO-A-2007/122375
US-B1- 7 328 053

EP 2 285 271 B1

Note: Within nine months of the publication of the mention of the grant of the European patent in the European Patent Bulletin, any person may give notice to the European Patent Office of opposition to that patent, in accordance with the Implementing Regulations. Notice of opposition shall not be deemed to have been filed until the opposition fee has been paid. (Art. 99(1) European Patent Convention).

Description

FIELD OF THE INVENTION

[0001] The invention relates to the field of light attenuation measurements, and especially to a method of and a device for monitoring a vital parameter of a patient by measuring attenuation of light emitted onto tissue of the patient

BACKGROUND OF THE INVENTION

[0002] The measurement of light absorption and/or scattering when propagating through or reflecting from a certain medium forms the basis of a number of optical spectroscopic methods widely applied in various medical domains, such as patient monitoring. An illustrative example is transmissive pulse oximetry.

[0003] Pulse oximetry is an optical method for non-invasive monitoring of arterial oxygen saturation of a patient and has become one of the most commonly used technologies in clinical practice. The protein haemoglobin (Hb) binds oxygen in the red blood cells for transport through the body, and has the property of changing from dark red to bright red in colour when oxygenated. By emitting and detecting light at two or more wavelengths, pulse oximeters determine the light absorbance in a peripheral vascular bed to arrive at an indirect estimate of oxygen saturation, i.e. the concentration fraction of oxyhaemoglobin (HbO₂). Pulse oximeters rely on the changes in arterial blood volume caused by cardiac contraction and relaxation to determine the amount of light absorbed by pulsating arterial blood alone, thereby largely factoring out the contributions of tissue and venous blood.

[0004] In many applications, including oximetry, simultaneous or quasi-simultaneous attenuation measurements of an optical path at different wavelengths, i.e. of different colours, are required. To that end, typically multiple light sources are utilized which are generally combined with a single photo-detector. In order to be able to distinguish between the signals from each of the emitters at the photo-detector, in general, electrical multiplexing methods are employed, such as time division multiplexing (TDM), frequency division multiplexing (FDM), or code division multiplexing (CDM).

[0005] In the medical practice, light attenuation measurements applied in e.g. patient monitoring suffer from electromagnetic interference. Typically such interference consists of ambient light at various optical wavelengths and with different modulation frequencies. Common examples include natural daylight, which is typically not modulated, as well as artificial light from incandescent lamps, which is modulated at the double mains frequency (100 Hz or 120 Hz) and 50 Hz or 60 Hz harmonics, and from fluorescent lamps with flicker rates ranging from tens to hundreds of kilohertz depending on the specific electronic ballast.

[0006] Generally, in spectrometric devices measures

are taken to mitigate the effect of external interference on the measurements. For example in pulse oximeters, the light sources are modulated such that at the photo-detector the emitted light can be distinguished from ambient light by filtering or demodulation. Regardless of the modulation techniques applied, conventional methods rely on knowledge of the spectral modulation of the environmental light and assume that the light source modulation frequency or band that is used can remain fixed for the lifetime of the device. However, if the ambient light modulation spectrum is only partly or not known a priori, such as is the case when the spectrometric device operates in the vicinity of light communication systems, then interference may be present in the modulation spectrum of the detected light at the device operation frequency. Similarly, new operation schemes of high-intensity discharge (HID) lamps might result in interference signal with a wide frequency range. Moreover, emerging light emitting diodes (LEDs) light sources are foreseen to use a wide range of modulation frequencies, creating new sources of interferences. If an interferer contaminates the operation frequency band, the signal-to-interference ratio (SIR) may decrease to a large extent, thereby degrading the measurement quality.

[0007] EP1655881A1 discloses a system, which is used in a patient medical parameter, such as a patient blood oxygen saturation parameter, monitoring system for reducing signal interference in modulated signal communication including a measurement processor that measures amplitudes of noise components of a received amplitude modulated signal prior to demodulation. The measurement processor also identifies a frequency of a noise component having an amplitude larger than the amplitude of another noise component. A carrier frequency is generated substantially at a harmonic of the identified noise component and is used to generate and demodulate the amplitude modulated signal.

SUMMARY OF THE INVENTION

[0008] It is an object of the invention to provide such a method of monitoring a vital parameter of a patient by measuring attenuation of light emitted onto tissue of the patient and an according device which allow for a high signal-to-interference ratio in a versatile and reliable way.

[0009] This object is achieved by a method of monitoring a vital parameter of a patient by measuring attenuation of light emitted onto tissue of the patient, comprising the following steps:

- modulating the light according to a modulation mode;
- emitting the modulated light onto the tissue of the patient;
- collecting ambient light and/or light which is transmitted through the tissue and/or light which is reflected from the tissue;
- demodulating the collected light according to the modulation mode;

analyzing the demodulated collected light with regard to the contribution of the ambient light; determining a modulation mode for which the contribution of the ambient light is minimized or falls under a predefined threshold; and setting the modulation mode for modulating the light according to the determined modulation mode for which the contribution of the ambient light is minimized or falls under a predefined threshold.

[0010] According to the invention, light which is transmitted through the tissue or/and which is reflected from the tissue is collected which is necessary for the attenuation measurement in order to monitor the vital parameter of the patient. However, when collecting this light, it cannot totally be avoided to collect at least some ambient light, too. Thus, the step of "collecting ambient light" does not mean that special measures have to be taken in order to collect this ambient light. Though, of course, it lies within the scope of the invention to take such measures, ambient light will always be collected when transmitted and/or reflected light is collected. Further, if no transmitted and/or reflected light exists since no light is emitted, ambient light can be collected, too. This means that above mentioned steps of the method according to the invention do not have to be executed simultaneously. Especially, this means that the step of "collecting ambient light and/or light which is transmitted through the tissue and/or light which is reflected from the tissue" can be executed during the emission of modulated light and/or in a time period in which no modulated light is emitted and, thus, only ambient light is collected.

[0011] Hence, it is an important idea of the invention to adapt the modulation scheme during operation, i.e. "in-situ", to the modulation spectrum of the ambient light. Due to setting the modulation scheme, i.e. the modulation frequency or the modulation code, "in-situ" according to the interference with the ambient light which is determined "in-situ" on the basis of the contribution of the ambient light, the negative impact of the ambient light on the signal-to-interference ratio is greatly reduced.

[0012] It should be emphasized that the term "patient" does not only refer to diseased persons but to all human beings and animals, no matter whether healthy or not.

[0013] In general, there are different ways for performing the invention. However, according to a preferred embodiment of the invention, the modulation mode is a modulation frequency or/and a modulation code.

[0014] Further, according to a preferred embodiment of the invention, the step of emitting light onto the tissue of the patient is interrupted for a predefined interruption time period, during this interruption time period the collected light is successively demodulated with different modulation frequencies, and the modulation frequency for which the output of demodulating the collected light is minimized or falls under a predefined threshold is determined to be the modulation frequency for the light emitted onto the tissue of the patient after the predefined in-

terruption time period. Thus, according to this preferred embodiment of the invention, the fact is used that the method can be operated at different frequencies, i.e. different FDM modes. Preferably, these different FDM modes are approximately, most preferably exactly, orthogonal to each other in the frequency domain.

[0015] With respect to this preferred embodiment of the invention it is further preferred that the different modulation frequencies are a discrete set of frequencies or are continuous within a predefined range. Further, the step of emitting light onto the tissue of the patient is preferably interrupted periodically. Furthermore, instead of alternately changing between attenuation measurements and frequency adaptation, it is preferred that an adaptation phase is initiated based on the analysis of the demodulator output.

[0016] According to another preferred embodiment of the invention, the step of emitting light onto the tissue of the patient is interrupted for a predefined interruption time period, during this interruption time period the collected light is successively demodulated with different modulation codes, and the modulation code for which the output of demodulating the collected light is minimized or falls under a predefined threshold is determined to be the modulation code for the light emitted onto the tissue of the patient after the predefined interruption time period.

[0017] Further, similar to the preferred embodiment of the invention described before, the step of emitting light onto the tissue of the patient is preferably interrupted periodically. Furthermore, instead of alternately changing between attenuation measurements and code adaptation, it is preferred that an adaptation phase is initiated based on the analysis of the demodulator output.

[0018] Moreover, with respect to using modulation codes instead of modulation frequencies, in the case that the step of analyzing the demodulated collected light with regard to the contribution of the ambient light yields a lower level of contribution, a shorter modulation code is applied; and in the case that the step of analyzing the demodulated collected light with regard to contribution of the ambient light yields a higher level of contribution, a longer modulation code is applied.

[0019] Further, according to a preferred embodiment of the invention, the step of emitting light onto the tissue of the patient is interrupted for a predefined interruption time period, during this interruption time period the power spectrum of the collected light is determined using a Fourier transform, and the frequency for which the power spectrum is determined to have its minimum or a frequency for which the power spectrum falls below a predefined threshold is determined to be the modulation frequency for the light emitted onto the tissue of the patient after the predefined interruption time period. Thus, this preferred embodiment of the invention is related to directly evaluating the spectrum of the collected light, i.e. before demodulation. Also with respect to this preferred embodiment it is further preferred that the step of emitting light onto the tissue of the patient is periodically interrupt-

ed.

[0020] According to another preferred embodiment of the invention, the modulation frequency of the light emitted onto the tissue is consecutively changed by cycling through a predefined set of at least two frequency modes or frequency bands; and the modulation frequency for which the output of demodulating the collected light is maximized or exceeds a predefined threshold is determined to be the active modulation frequency for the light emitted onto the tissue of the patient. This preferred method is also referred to as frequency hopping.

[0021] In this case, the set of frequencies is preferably adapted in order to avoid interference by modulated ambient light. Generally, it can be expected that the ambient light modulation spectrum does not cover the entire frequency set, and it can be assumed that at least one of the modulation frequencies is free of interference. To that end, the frequency set is preferably chosen such that a high spectral diversity is guaranteed. Therefore the detected light for at least one of the frequencies in the set, i.e. the one that is free of disturbance, results in a maximum attenuation measurement. For a given colour of light, attenuation measurements are independent of the modulation frequencies. If another frequency in the set results in a lower attenuation measurement, this is a result of interference in that modulation frequency band, and the corresponding frequency is preferably replaced.

[0022] In principle, a new frequency in the set can be chosen arbitrarily or based on some selection criterion. Preferably, spectral sensing, as described before, is applied to select the initial set for frequency hopping and also to replace frequencies in the set. In case of this preferred embodiment of the invention, emitting the light onto the tissue of the patient is preferably not interrupted. Preferably, a new modulation frequency or set is selected while another modulation frequency is used. Further, it is especially preferred, that a set of only two frequencies is used, wherein the second modulation frequency is chosen from the spectrum when the attenuation is measured using the first frequency and vice versa, thereby continuously seeking the optimal modulation frequency.

[0023] The advantage of adaptive modulation frequency hopping is that the method is based on the quasi-simultaneous evaluation of the received signal at multiple frequencies, thereby allowing continuous measurement without interruption by an adaptation phase.

[0024] Above mentioned object is further addressed by a device for monitoring a vital parameter of a patient by measuring attenuation of light emitted onto tissue of the patient, with

a light modulator adapted for modulating the light according to a modulation mode;
 a light emitter adapted for emitting the modulated light onto the tissue of the patient;
 a light detector adapted for light which is transmitted through the tissue or/and which is reflected from the tissue and unavoidably being adapted for collecting

ambient light;

a light demodulator adapted for demodulating the collected light according to the modulation mode;
 an interference analyzer adapted for analyzing the demodulated collected light with regard to the contribution of the ambient light; and a processing unit adapted for determining a modulation mode for which the contribution of the ambient light is minimized or falls under a predefined threshold and for setting the modulation mode for modulating the light according to the determined modulation mode for which the contribution of the ambient light is minimized or falls under a predefined threshold.

[0025] With respect to the device according to the preferred embodiment of the invention, this device is adapted for emitting light with at least two different wavelengths. Further, it is especially preferred that the device is a pulse oximeter.

BRIEF DESCRIPTION OF THE DRAWINGS

[0026] These and other aspects of the invention will be apparent from and elucidated with reference to the embodiments described hereinafter.

[0027] In the drawings:

Fig. 1 shows a typical setup for transmission pulse oximetry;

Fig. 2 depicts a generalized block diagram of a transmission pulse oximetry method according to an embodiment of the invention;

Fig. 3 shows a demodulator with a periodic square wave reference signal;

Fig. 4 shows spectra of different FDM modes according to an embodiment of the invention; and

Fig. 5 shows spectra of different codes from the WH256 code book.

DETAILED DESCRIPTION OF EMBODIMENTS

[0028] According to an embodiment of the invention, instead of fixing the light modulation frequency bands upon manufacturing of the attenuation measurement device, the modulation scheme is adapted "in-situ" to the modulation spectrum of the ambient light. This modulation scheme is realized by actively monitoring the ambient light or the effect thereof on the detection performance, and changing the transmission and/or detection parameters such that interference with modulated ambient light is avoided or suppressed.

Fig. 1 shows a typical setup for transmission pulse oximetry: A red light source 1 and an infrared (IR) light source 2 are used for irradiating red light of 660 nm and IR light of 940 nm onto tissue of a patient, i.e. onto a finger 3. The part of the light which is transmitted through the finger 3 is then collected with a

common light detector 4.

Fig. 2 depicts a general block diagram of a transmission pulse oximeter according to an embodiment of the invention. The system comprises a processing unit 5 that adjusts the parameters of a light modulator 6 which acts a pulse controller and modulates the light sources 1, 2. The configuration of the light modulator 6 depends on the specific multiplexing scheme applied, e.g. in case of TDM the light sources 1, 2 are activated alternately, whereas for FDM the light sources 1, 2 radiate light simultaneously but with different modulation frequencies. The reason for the multiplexing scheme is that in this way the same light detector 4 can be used to estimate the attenuation of the light from both light sources 1, 2.

[0029] The light detector 4 detects the light that has propagated through the medium of the finger 3 and converts it into an electrical signal. This signal is then pre-processed by a signal-conditioning block 8, which comprises analog amplifiers and bandpass filters, which make the signal suitable for conversion to the digital domain by an analog-to-digital converter (ADC) 9. Correlators 10, each comprising a demodulator 11 and a demultiplexer 12, are used to simultaneously demodulate and demultiplex the detected light, and the results are presented to the processing unit 5, which determines the parameters of interest by evaluating the transmitted and demodulated signals. For that, the processing unit comprises an interference analyzer 14.

[0030] The scheme according to the embodiment of the invention is independent of the specific multiplexing technique applied, since all attenuation measurement methods incorporate a certain modulation method. To simplify matters, the description of the following embodiments is restricted to a single light source, thereby disregarding the specific demultiplexing method. For a single light source, only one correlator 10 is necessary. This correlator 10 then simply equals a demodulator 11, such as depicted in Fig. 3. Here, the information on the light attenuation becomes present in the base-band by multiplying the received signal with a local reference of the same fundamental frequency ($f_{in} = 1/T_m$). Subsequently, only the base-band signal is preserved by passing the signal through a low-pass filter 13, thereby disregarding out-of-band interference.

[0031] It should be noted that the square wave in Fig. 3 is only illustrative, as any periodic signal can be applied to both modulate the light sources 1, 2 and demodulate the received signal as long as the fundamental frequencies and/or harmonics coincide.

[0032] According to a first embodiment of the invention, the fact is applied that the system can operate at different frequencies or FDM modes. These FDM modes, as illustrated in Fig. 4, are approximately orthogonal in the frequency domain. When the experienced interference is spectral coloured, there exists a mode, which minimizes the experienced interference. Further, it

should be noted that a TDM system can be interpreted as also operating at a single or multiple FDM modes.

[0033] The system operation frequency (f_m) is adapted to a band where interference is low by evaluating the demodulator output (y). To that end, first the light source is turned off, then the demodulation frequency of the system is adapted, such that the demodulator output is minimized or becomes lower than a predefined threshold, and subsequently the modulation frequency is changed accordingly.

[0034] The method can either alternate periodically between attenuation measurements and frequency adaptation, or an adaptation phase can be initiated based on the analysis of the demodulator output signal. The frequencies to be considered can be a discrete set or continuous within a certain range. The processing unit can either adapt the demodulation frequency until some selection criterion is fulfilled, e.g. a certain minimum SIR is obtained; or evaluate the entire range or set of frequencies and then select the optimum; or evaluate the predefined frequency space by a search algorithm.

[0035] A respective behaviour can also be realized according to another embodiment of the invention by directly evaluating the spectrum of the received signal, i.e. before demodulating the signal, and selecting a frequency or frequency set where interference is low. To that end, first the light is turned off, and then the power spectrum of the received signal (x) is determined using a discrete Fourier transform. Subsequently, a modulation and corresponding demodulation frequency (f_m) is selected from the minimum of the power spectrum or by applying a threshold to the power spectrum.

[0036] Again the method can either alternate periodically between attenuation measurements and frequency adaptation, or an adaptation phase can be initiated based on the analysis of the received signal or the demodulator output signal, e.g. by variations in instantaneous power.

[0037] Alternatively, the modulation frequency (f_m) can be changed continuously by cycling through a certain discrete set of at least two frequency modes or frequency bands, i.e. by frequency hopping. In this case, the set of frequencies is adapted in order to avoid interference by modulated ambient light. Generally, the ambient light modulation spectrum does not cover the entire frequency set, and it can be assumed that at least one of the modulation frequencies is free of interference. To that end, the frequency set should be chosen initially such that sufficient spectral diversity is guaranteed. Therefore the detected light for at least one of the frequencies in the set, i.e. the one that is free of disturbance, results in a maximum attenuation measurement. Clearly, for a given colour of light, attenuation measurements are independent of the modulation frequencies. Now, if another frequency in the set results in a lower attenuation measurement, this is a result of interference in that modulation frequency band, and the corresponding frequency should be replaced.

[0038] In principle, a new frequency in the set can be

chosen arbitrarily or based on some selection criterion. Spectral sensing, as described in the previous embodiment, may be applied to select the initial set for frequency hopping and also to replace frequencies in the set. In order to achieve this functionality, the light source does not have to be turned off, and a new modulation frequency or a set can be selected while another modulation frequency is being used. It should be noted, that it is especially preferred that only two frequencies are used, wherein the second modulation frequency is chosen from the spectrum when the attenuation is measured using the first frequency and vice versa, thereby continuously seeking the optimal modulation frequency.

[0039] The advantage of such adaptive modulation frequency hopping is that the method is based on the quasi-simultaneous evaluation of the received signal at multiple frequencies, thereby allowing continuous measurement without interruption by an adaptation phase.

[0040] According to another embodiment of the invention, CDM is used, wherein the different light sources use unique, preferably orthogonal, codes to enable the light detector to distinguish their light contributions. Suitable orthogonal codes are e.g. Walsh-Hadamard (WH) codes, where the number of light sources that can be accommodated is roughly equal to the length of the code. Next to allowing for identification of the light contributions of the different light sources, these codes also shape the spectrum of the light signal. As an example all except one WH code achieve a DC-free spectrum and their spectra are mutually different.

[0041] This is illustrated in Fig. 5 for WH codes of length 256. There, the spectra of 4 out of the 256 codes in the codebook are depicted. As can be concluded from Fig. 5, these codes have significantly different spectra. Similarly, correlation at the receiving end with the spreading codes achieves suppression of frequencies not related to the transmitted code. It should be noted that, in contrast to the frequency multiplexing illustrated in Fig. 3, the spectra achieved by these codes will generally be overlapping.

[0042] The modulation scheme is then implemented by adaptive code selection. The spreading or modulation code used by the system is adapted to the one, that is least affected by the interference, i.e. the code that is most orthogonal to the interference. This is done by evaluating the demodulator output. To that end, the technique of the first embodiment described above can be applied, where first the light is turned off, then the demodulation code of the system is adapted, such that the demodulator output is minimized or becomes lower than a certain threshold, and subsequently the transmitter spreading code is changed accordingly.

[0043] It should be noted that also the accuracy/reliability of the attenuation measurement can be scaled in such a solution by applying codes with different codes lengths, i.e. when the level of interference is low, a short code is used and when it is high, a higher code length is used. The advantage of longer codes is that they achieve

better spectral shaping and thus yield a better noise and interference suppression at the receiving end. The advantage of short codes is that they reduce the measurement time.

5 **[0044]** Above embodiments have been described for a single light source. In these solutions the system searches for the optimal modulation frequency/code. For a system with N light sources, however, the system finds a set of N codes/frequencies for which the impact of the
10 interference and noise is minimized/below a certain threshold. Here it is possible to choose to minimize the worst-case error for one of the light sources or the average error for all light sources, depending on the operation mode.

15 **[0045]** While the invention has been illustrated and described in detail in the drawings and foregoing description, such illustration and description are to be considered illustrative or exemplary and not restrictive; the invention is not limited to the disclosed embodiments.

20 **[0046]** Other variations to the disclosed embodiments can be understood and effected by those skilled in the art in practicing the claimed invention, from a study of the drawings, the disclosure, and the appended claims. In the claims, the word "comprising" does not exclude
25 other elements or steps, and the indefinite article "a" or "an" does not exclude a plurality. The mere fact that certain measures are recited in mutually different dependent claims does not indicate that a combination of these measures cannot be used to advantage. Any reference
30 signs in the claims should not be construed as limiting the scope.

Claims

- 35
1. A method of monitoring a vital parameter of a patient by measuring attenuation of light emitted onto tissue of the patient, comprising the following steps:
 - 40 modulating the light according to a modulation mode;
 - emitting the modulated light onto the tissue of the patient;
 - collecting ambient light and/or light which is transmitted through the tissue and/or light which is reflected from the tissue;
 - 45 demodulating the collected light according to the modulation mode;
 - analyzing the demodulated collected light with regard to the contribution of the ambient light;
 - determining a modulation mode for which the contribution of the ambient light is minimized or falls under a predefined threshold; and
 - 50 setting the modulation mode for modulating the light according to the determined modulation mode for which the contribution of the ambient light is minimized or falls under a predefined threshold.
- 55

2. The method according to claim 1, wherein the modulation mode is a modulation frequency or/and a modulation code.
3. The method according to claim 2, wherein the step of emitting light onto the tissue of the patient is interrupted for a predefined interruption time period, during this interruption time period the collected light is successively demodulated with different modulation frequencies, and the modulation frequency for which the output of demodulating the collected light is minimized or falls under a predefined threshold is determined to be the modulation frequency for the light emitted onto the tissue of the patient after the predefined interruption time period.
4. The method according to claim 3, wherein the different modulation frequencies are a discrete set of frequencies or are continuous within a predefined range.
5. The method according to claim 2, wherein the step of emitting light onto the tissue of the patient is interrupted for a predefined interruption time period, during this interruption time period the collected light is successively demodulated with different modulation codes, and the modulation code for which the output of demodulating the collected light is minimized or falls under a predefined threshold is determined to be the modulation code for the light emitted onto the tissue of the patient after the predefined interruption time period.
6. The method according to claim 5, wherein in the case that the step of analyzing the demodulated collected light with regard to the contribution of the ambient light yields a lower level of contribution, a shorter modulation code is applied; and in the case that the step of analyzing the demodulated collected light with regard to contribution of the ambient light yields a higher level of contribution, a longer modulation code is applied.
7. The method according to claim 2, wherein the step of emitting light onto the tissue of the patient is interrupted for a predefined interruption time period, during this interruption time period the power spectrum of the collected light is determined using a Fourier transform, and the frequency for which the power spectrum is determined to have its minimum or a frequency for which the power spectrum falls below a predefined threshold is determined to be the modulation frequency for the light emitted onto the tissue of the patient after the predefined interruption time period.
8. The method according to any of claims 3 to 7, wherein the step of emitting light onto the tissue of the patient is periodically interrupted.
9. The method according to claim 2, wherein the modulation frequency of the light emitted onto the tissue is consecutively changed by cycling through a predefined set of at least two frequency modes or frequency bands; and the modulation frequency for which the output of demodulating the collected light is maximized or exceeds a predefined threshold is determined to be the active modulation frequency for the light emitted onto the tissue of the patient.
10. The method according to claim 9, wherein during emitting light onto the tissue of the patient with a first modulation frequency, a second modulation frequency is selected from a predefined spectrum and vice versa.
11. The method according to any of claims 1 to 10, wherein the light emitted onto tissue of the patient comprises at least a first light and a second light, wherein the wavelength of the first light is different from the wavelength of the second light, and wherein the first light and the second light are multiplexed.
12. The method according to claim 11, wherein time division multiplexing, frequency multiplexing or/and code division multiplexing is applied.
13. The method according to claim 11 or 12, wherein the step of determining a modulation frequency or/and a modulation code for which the contribution of the ambient light is minimized or falls under a predefined threshold is done for only one of the first light and the second light, or is done for an average of the first light and the second light.
14. Device for monitoring a vital parameter of a patient by measuring attenuation of light emitted onto tissue of the patient, with
a light modulator (6) adapted for modulating the light according to a modulation mode;
a light emitter (1, 2) adapted for emitting the modulated light onto the tissue of the patient;
a light detector (4) adapted for light which is transmitted through the tissue or/and which is reflected from the tissue and unavoidably being adapted for collecting ambient light;
a light demodulator (11) adapted for demodulating the collected light according to the modulation mode;
an interference analyzer (14) adapted for analyzing the demodulated collected light with regard to the contribution of the ambient light; and
a processing unit (5) adapted for determining a modulation mode for which the contribution of the ambi-

ent light is minimized or falls under a predefined threshold and for setting the modulation mode for modulating the light according to the determined modulation mode for which the contribution of the ambient light is minimized or falls under a predefined threshold.

15. The device according to claim 14, wherein at least two light sources (1, 2) for emitting light with two different wavelengths are provided.

Patentansprüche

1. Verfahren zur Überwachung eines Vitalparameters eines Patienten durch Messen der Abschwächung von auf das Gewebe des Patienten emittiertem Licht, wobei das Verfahren die folgenden Schritte umfasst:

Modulieren des Lichts entsprechend einem Modulationsmodus;
 Emittieren des modulierten Lichts auf das Gewebe des Patienten;
 Erfassen des Umgebungslichts und/oder des durch das Gewebe weitergeleiteten Lichts und/oder des durch das Gewebe reflektierten Lichts;
 Demodulieren des erfassten Lichts entsprechend dem Modulationsmodus;
 Analysieren des demodulierten erfassten Lichts in Bezug auf den Anteil an Umgebungslicht;
 Ermitteln eines Modulationsmodus, bei dem der Anteil des Umgebungslichts minimiert wird oder unter einen vorgegebenen Schwellenwert fällt; und
 Einstellen des Modulationsmodus zum Modulieren des Lichts entsprechend dem ermittelten Modulationsmodus, bei dem der Anteil des Umgebungslichts minimiert wird oder unter einen vorgegebenen Schwellenwert fällt.

2. Verfahren nach Anspruch 1, wobei der Modulationsmodus eine Modulationsfrequenz und/oder ein Modulationscode ist.
3. Verfahren nach Anspruch 2, wobei der Schritt des Emittierens von Licht auf das Gewebe des Patienten für eine vorgegebene Unterbrechungszeitdauer unterbrochen wird, während dieser Unterbrechungszeitdauer das erfasste Licht nacheinander mit verschiedenen Modulationsfrequenzen demoduliert wird, und die Modulationsfrequenz, bei der die Ausgabe des Demodulierens des erfassten Lichts minimiert wird oder unter einen bestimmten Schwellenwert fällt, als die Modulationsfrequenz für das nach der vorgegebenen Unterbrechungszeitdauer auf das Gewebe des Patienten emittierte Licht ermittelt wird.

4. Verfahren nach Anspruch 3, wobei die verschiedenen Modulationsfrequenzen ein diskreter Satz von Frequenzen sind oder innerhalb eines vorgegebenen Bereichs kontinuierlich sind.

5. Verfahren nach Anspruch 2, wobei der Schritt des Emittierens von Licht auf das Gewebe des Patienten für eine vorgegebene Unterbrechungszeitdauer unterbrochen wird, während dieser Unterbrechungszeitdauer das erfasste Licht nacheinander mit verschiedenen Modulationscodes demoduliert wird, und der Modulationscode, bei dem die Ausgabe des Demodulierens des erfassten Lichts minimiert wird oder unter einen vorgegebenen Schwellenwert fällt, als der Modulationscode für das nach der vorgegebenen Unterbrechungszeitdauer auf das Gewebe des Patienten emittierte Licht ermittelt wird.

6. Verfahren nach Anspruch 5, wobei in dem Fall, dass der Schritt des Analysierens des demodulierten erfassten Lichts in Bezug auf den Anteil des Umgebungslichts ein geringeres Anteilsmaß ergibt, ein kürzerer Modulationscode angewendet wird; und in dem Fall, dass der Schritt des Analysierens des demodulierten erfassten Lichts in Bezug auf den Anteil des Umgebungslichts ein höheres Anteilsmaß ergibt, ein längerer Modulationscode angewendet wird.

7. Verfahren nach Anspruch 2, wobei der Schritt des Emittierens von Licht auf das Gewebe des Patienten für eine vorgegebene Unterbrechungszeitdauer unterbrochen wird, während dieser Unterbrechungszeitdauer das Leistungsspektrum des erfassten Lichts unter Verwendung einer Fourier-Transformation ermittelt wird, und die Frequenz, bei der für das Leistungsspektrum ein Minimum ermittelt wird oder eine Frequenz, bei der das Leistungsspektrum unter einen vorgegebenen Schwellenwert fällt, als die Modulationsfrequenz für das nach der vorgegebenen Unterbrechungszeitdauer auf das Gewebe des Patienten emittierte Licht ermittelt wird.

8. Verfahren nach einem der Ansprüche 3 bis 7, wobei der Schritt des Emittierens von Licht auf das Gewebe des Patienten periodisch unterbrochen wird.

9. Verfahren nach Anspruch 2, wobei die Modulationsfrequenz des auf das Gewebe emittierten Lichts aufeinanderfolgend geändert wird, indem ein vorgegebener Satz von mindestens zwei Frequenzmodi oder Frequenzbändern durchlaufen wird; und die Modulationsfrequenz, bei der die Ausgabe des Demodulierens des erfassten Lichts maximiert wird oder einen vorgegebenen Schwellenwert über-

schreitet, als die aktive Modulationsfrequenz für das auf das Gewebe des Patienten emittierte Licht ermittelt wird.

10. Verfahren nach Anspruch 9, wobei während des Emittierens des Lichts auf das Gewebe des Patienten mit einer ersten Modulationsfrequenz eine zweite Modulationsfrequenz aus einem vorgegebenen Spektrum ausgewählt wird und umgekehrt. 5
11. Verfahren nach einem der Ansprüche 1 bis 10, wobei das auf das Gewebe des Patienten emittierte Licht mindestens ein erstes Licht und ein zweites Licht umfasst, wobei sich die Wellenlänge des ersten Lichts von der Wellenlänge des zweiten Lichts unterscheidet, und wobei das erste Licht und das zweite Licht gemultiplext werden. 10
12. Verfahren nach Anspruch 11, wobei Time-Division-Multiplexen, Frequenz-Multiplexen und/oder Code-Division-Multiplexen angewendet wird. 15
13. Verfahren nach Anspruch 11 oder 12, wobei der Schritt des Ermittlens einer Modulationsfrequenz und/oder eines Modulationscodes, bei der bzw. bei dem der Anteil des Umgebungslichts minimiert wird oder unter einen vorgegebenen Schwellenwert fällt, nur für entweder das erste Licht oder das zweite Licht durchgeführt wird, oder für einen Mittelwert des ersten Lichts und des zweiten Lichts durchgeführt wird. 20
14. Vorrichtung zur Überwachung eines Vitalparameters eines Patienten durch Messen der Abschwächung von auf das Gewebe des Patienten emittiertem Licht, wobei die Vorrichtung Folgendes umfasst: 25
- einen Lichtmodulator (6), der vorgesehen ist, um das Licht entsprechend einem Modulationsmodus zu modulieren;
 - einen Lichtemitter (1, 2), der vorgesehen ist, um das modulierte Licht auf das Gewebe des Patienten zu emittieren;
 - einen Lichtdetektor (4), der für Licht vorgesehen ist, das durch das Gewebe weitergeleitet wird und/oder das durch das Gewebe reflektiert wird und der zwangsläufig für das Erfassen von Umgebungslicht vorgesehen ist;
 - einen Lichtdemodulator (11), der vorgesehen ist, um das erfasste Licht entsprechend dem Modulationsmodus zu demodulieren;
 - einen Interferenzanalysator (14), der vorgesehen ist, um das demodulierte erfasste Licht in Bezug auf den Anteil an Umgebungslicht zu analysieren; und
 - eine Verarbeitungseinheit (5), die vorgesehen ist, um einen Modulationsmodus zu ermitteln, bei dem der Anteil des Umgebungslichts minimiert wird oder unter einen vorgegebenen 30

Schwellenwert fällt, und um den Modulationsmodus zum Modulieren des Lichts entsprechend dem ermittelten Modulationsmodus einzustellen, bei dem der Anteil des Umgebungslichts minimiert wird oder unter einen vorgegebenen Schwellenwert fällt.

15. Vorrichtung nach Anspruch 14, wobei mindestens zwei Lichtquellen (1, 2) zum Emittieren von Licht mit zwei unterschiedlichen Wellenlängen vorgesehen sind. 35

Revendications

1. Procédé de surveiller un paramètre vital d'un patient en mesurant une atténuation de lumière émise sur un tissu du patient, comprenant les étapes suivantes consistant à :
- moduler la lumière selon un mode de modulation ;
 - émettre la lumière modulée sur le tissu du patient ;
 - collecter lumière ambiante et/ou lumière qui est transmise à travers le tissu et/ou de la lumière qui est réfléchie à partir du tissu ;
 - démoduler la lumière collectée selon le mode de modulation ;
 - analyser la lumière collectée démodulée par rapport à la contribution de la lumière ambiante ;
 - déterminer un mode de modulation pour lequel la contribution de la lumière ambiante est minimisée ou tombe sous un seuil prédéfini ; et
 - régler le mode de modulation pour moduler la lumière selon le mode de modulation déterminé pour lequel la contribution de la lumière ambiante est minimisée ou tombe sous un seuil prédéfini. 40
2. Procédé selon la revendication 1, dans lequel le mode de modulation est une fréquence de modulation ou/et un code de modulation. 45
3. Procédé selon la revendication 2, dans lequel l'étape consistant à émettre de la lumière sur le tissu du patient est interrompue pendant une période d'interruption prédéfinie, au cours de cette période d'interruption la lumière collectée est successivement démodulée avec des fréquences de modulation différentes, et la fréquence de modulation pour lequel la sortie de l'étape consistant à démoduler la lumière collectée est minimisée ou tombe sous un seuil prédéfini est déterminée comme étant la fréquence de modulation pour la lumière émise sur le tissu du patient après la période d'interruption prédéfinie. 50

4. Procédé selon la revendication 3, dans lequel les fréquences de modulation différentes sont un jeu discret de fréquences ou sont continues au sein d'une plage prédéfinie.
5. Procédé selon la revendication 2, dans lequel l'étape consistant à émettre de la lumière sur le tissu du patient est interrompue pendant une période d'interruption prédéfinie, au cours de cette période d'interruption, la lumière collectée est successivement démodulée avec des codes de modulation différents, et le code de modulation pour lequel la sortie de l'étape consistant à démoduler la lumière collectée est minimisée ou tombe sous un seuil prédéfini est déterminé comme étant le code de modulation pour la lumière émise sur le tissu du patient après la période d'interruption prédéfinie.
6. Procédé selon la revendication 5, dans lequel, au cas où l'étape consistant à analyser la lumière collectée démodulée par rapport à la contribution de la lumière ambiante produit un niveau plus bas de contribution, un code de modulation plus court est appliqué ; et, au cas où l'étape consistant à analyser la lumière collectée démodulée par rapport à la contribution de la lumière ambiante produit un niveau plus élevé de contribution, un code de modulation plus long est appliqué.
7. Procédé selon la revendication 2, dans lequel l'étape consistant à émettre de la lumière sur le tissu du patient est interrompue pendant une période d'interruption prédéfinie, au cours de cette période d'interruption, le spectre de puissance de la lumière collectée est déterminé en utilisant une transformée de Fourier, et la fréquence pour laquelle le spectre de puissance est déterminé comme posséder son minimum ou une fréquence pour laquelle le spectre de puissance tombe en dessous d'un seuil prédéfini est déterminée comme étant la fréquence de modulation pour la lumière émise sur le tissu du patient après la période d'interruption prédéfinie.
8. Procédé selon une quelconque des revendications 3 à 7, dans lequel l'étape consistant à émettre de la lumière sur le tissu du patient est périodiquement interrompue.
9. Procédé selon la revendication 2, dans lequel la fréquence de modulation de la lumière émise sur le tissu est changée consécutivement en réalisant un cycle à travers un jeu prédéfini d'au moins deux modes de fréquence ou bandes de fréquence ; et la fréquence de modulation pour laquelle la sortie de l'étape consistant à démoduler la lumière collectée est maximisée ou dépasse un seuil prédéfini est déterminée comme étant la fréquence de modulation active pour la lumière émise sur le tissu du patient.
10. Procédé selon la revendication 9, dans lequel, au cours de l'étape consistant à émettre de la lumière sur le tissu du patient avec une première modulation de fréquence, une seconde modulation de fréquence est sélectionnée parmi un spectre prédéfini et vice versa.
11. Procédé selon une quelconque des revendications 1 à 10, dans lequel la lumière émise sur un tissu du patient comprend au moins une première lumière et une seconde lumière, dans lequel la longueur d'onde de la première lumière est différente de la longueur d'onde de la seconde lumière, et dans lequel la première lumière et la seconde lumière sont multiples.
12. Procédé selon la revendication 11, dans lequel un multiplexage par répartition en temps, un multiplexage par répartition en fréquence ou/et un multiplexage par répartition en code est appliqué.
13. Procédé selon la revendication 11 ou 12, dans lequel l'étape consistant à déterminer une fréquence de modulation ou/et un code de modulation pour lequel la contribution de la lumière ambiante est minimisée ou tombe sous un seuil prédéfini est réalisée pour seulement une de la première lumière et la seconde lumière, ou est réalisée pour une moyenne de la première lumière et la seconde lumière.
14. Dispositif pour surveiller un paramètre vital d'un patient en mesurant une atténuation de lumière émise sur un tissu du patient, avec un modulateur de lumière (6) adapté pour moduler la lumière selon un mode de modulation ; un émetteur de lumière (1, 2) adapté pour émettre la lumière modulée sur le tissu du patient ; un détecteur de lumière (4) adapté pour de la lumière qui est transmise à travers le tissu ou/et qui est réfléchi à partir du tissu et inévitablement adapté pour collecter de la lumière ambiante ; un démodulateur de lumière (11) adapté pour démoduler la lumière collectée selon le mode de modulation ; un analyseur d'interférence (14) adapté pour analyser la lumière collectée démodulée par rapport à la contribution de la lumière ambiante ; et une unité de traitement (5) adaptée pour déterminer un mode de modulation pour lequel la contribution de la lumière ambiante est minimisée ou tombe sous un seuil prédéfini et pour régler le mode de modulation pour moduler la lumière selon le mode de modulation déterminé pour lequel la contribution de la lumière ambiante est minimisée ou tombe sous un seuil prédéfini.

15. Dispositif selon la revendication 14, dans lequel au moins deux sources lumineuses (1, 2) pour émettre de la lumière avec deux longueurs d'onde différentes sont prévues.

5

10

15

20

25

30

35

40

45

50

55

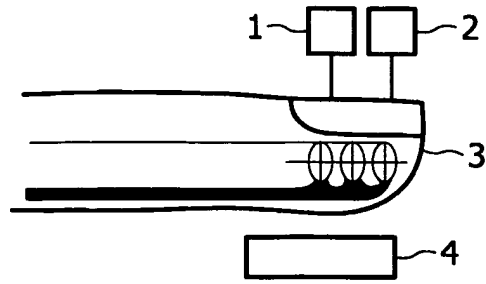

FIG. 1

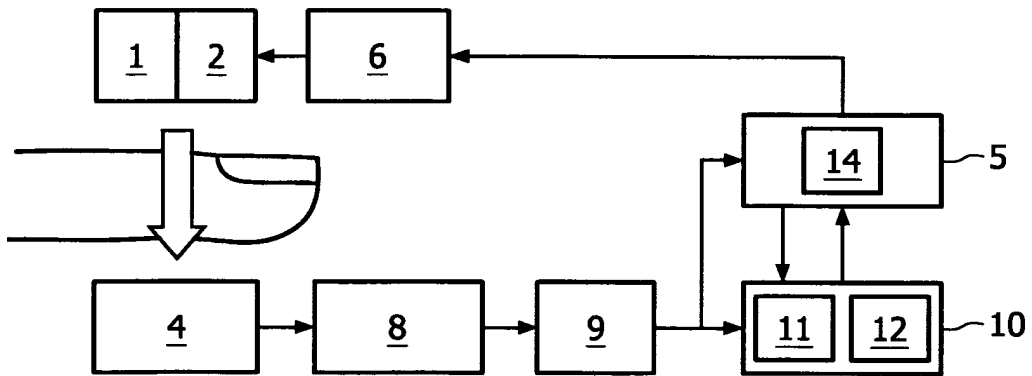

FIG. 2

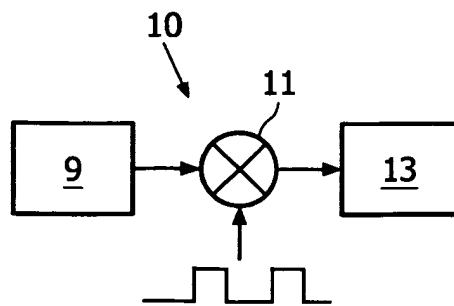

FIG. 3

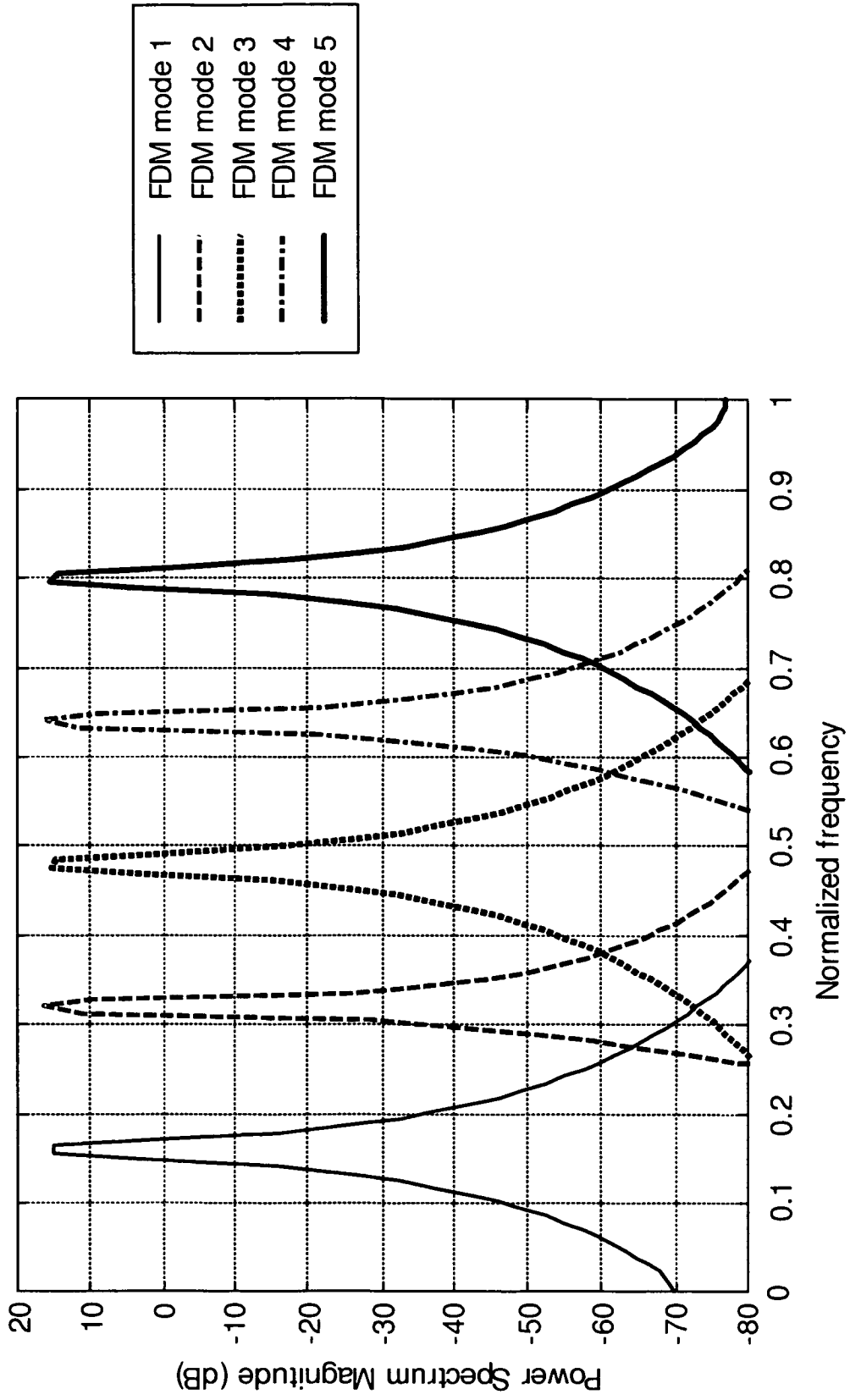

FIG. 4

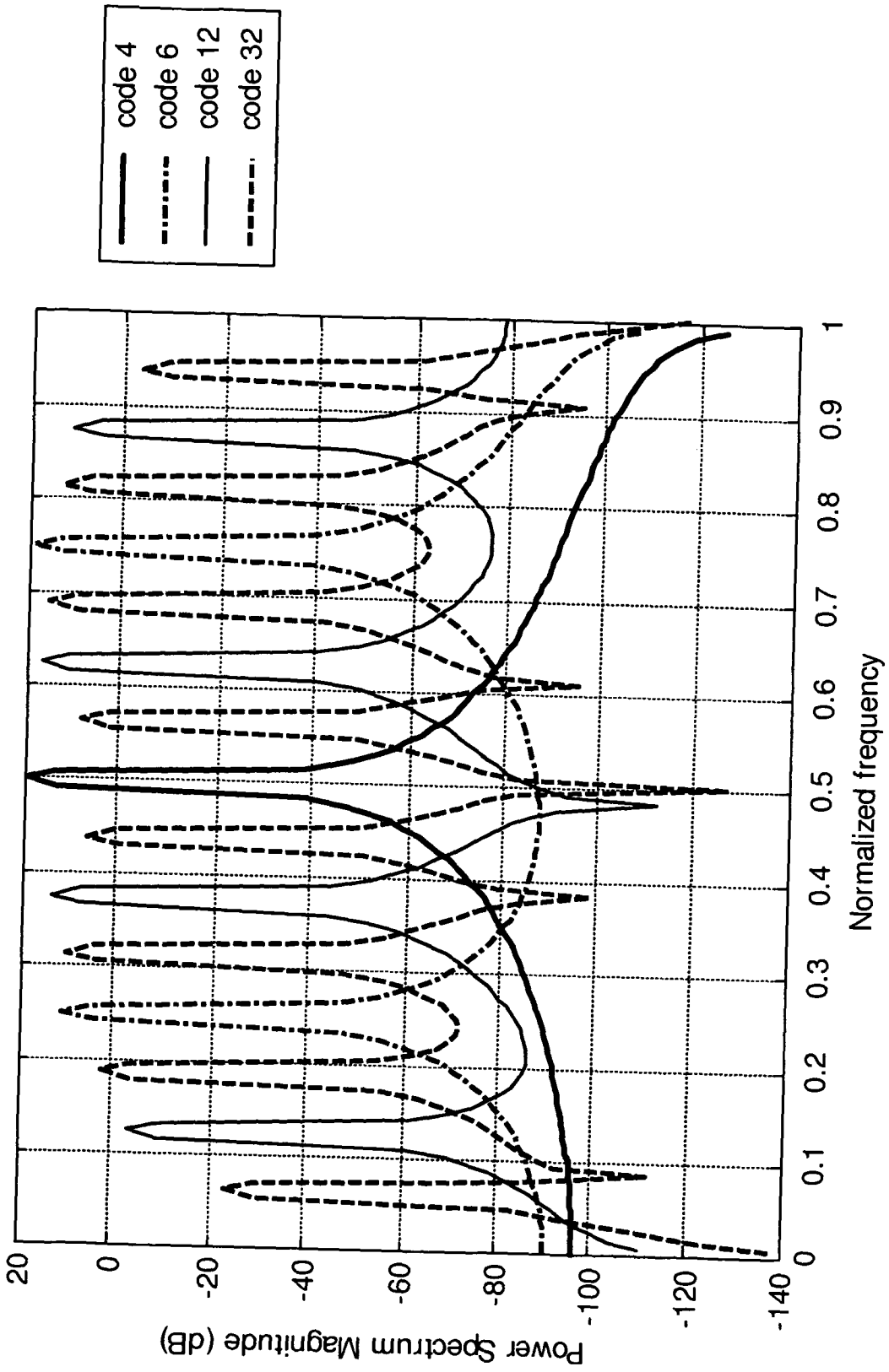

FIG. 5

REFERENCES CITED IN THE DESCRIPTION

This list of references cited by the applicant is for the reader's convenience only. It does not form part of the European patent document. Even though great care has been taken in compiling the references, errors or omissions cannot be excluded and the EPO disclaims all liability in this regard.

Patent documents cited in the description

- EP 1655881 A1 [0007]

专利名称(译)	使用“原位”调制方案监测患者的重要参数以避免干扰		
公开(公告)号	EP2285271B1	公开(公告)日	2011-09-07
申请号	EP2009766237	申请日	2009-06-09
[标]申请(专利权)人(译)	皇家飞利浦电子股份有限公司		
申请(专利权)人(译)	皇家飞利浦电子N.V.		
当前申请(专利权)人(译)	皇家飞利浦电子N.V.		
[标]发明人	VEEN JEROEN JANSEN THEODORUS P H G VERBERNE HENRICUS R M SCHENK TIM C W FERI LORENZO		
发明人	VEEN, JEROEN JANSEN, THEODORUS, P., H., G. VERBERNE, HENRICUS, R., M. SCHENK, TIM, C., W. FERI, LORENZO		
IPC分类号	A61B5/00		
CPC分类号	A61B5/14551 A61B5/0059		
优先权	2008104427 2008-06-16 EP		
其他公开文献	EP2285271A1		
外部链接	Espacenet		

摘要(译)

本发明涉及一种通过测量发射到患者组织上的光的衰减来监测患者的生命参数的方法，包括以下步骤：用调制频率或/和调制码调制光；将调制光发射到患者组织上；收集通过组织传播的光和/或从组织反射的光；解调收集的光；分析解调的采集光与环境光的干扰；确定调制频率或/和对环境光的干扰最小化或落在预定阈值之下的调制码；根据确定的调制频率设置用于调制光的调制频率或/和调制码，和/或将对环境光的干扰最小化或落在预定阈值之下的调制码。以这种方式，提供了以高信号干扰比监测患者的重要参数的通用且可靠的可能性。

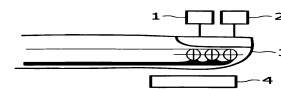

FIG. 1

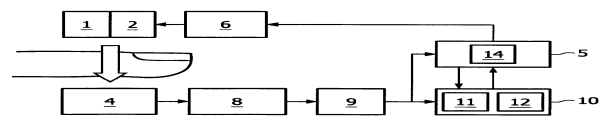

FIG. 2

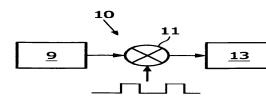

FIG. 3