

(19)



(11)

EP 2 257 780 B1

(12)

EUROPEAN PATENT SPECIFICATION

(45) Date of publication and mention of the grant of the patent:

04.05.2016 Bulletin 2016/18

(51) Int Cl.:

G01L 1/24 (2006.01) **G01L 11/02** (2006.01)
G02B 27/44 (2006.01) **A61B 5/00** (2006.01)
G02B 6/00 (2006.01) **G01L 9/00** (2006.01)
G01D 5/353 (2006.01)

(21) Application number: **09719900.4**

(22) Date of filing: **11.03.2009**

(86) International application number:
PCT/AU2009/000287

(87) International publication number:
WO 2009/111827 (17.09.2009 Gazette 2009/38)

(54) **AN OPTICAL DEVICE**

OPTISCHE VORRICHTUNG

DISPOSITIF OPTIQUE

(84) Designated Contracting States:

AT BE BG CH CY CZ DE DK EE ES FI FR GB GR HR HU IE IS IT LI LT LU LV MC MK MT NL NO PL PT RO SE SI SK TR

- **BLENMAN, Neil**
Campbell, ACT 2612 (AU)

(30) Priority: **11.03.2008 AU 2008901137**

(43) Date of publication of application:
08.12.2010 Bulletin 2010/49

(74) Representative: **Wallace, Alan Hutchinson et al**
FRKelly
4 Mount Charles
Belfast, Northern Ireland BT7 1NZ (GB)

(73) Proprietor: **Commonwealth Scientific and Industrial Research Organisation**
Campbell, Australian Capital Territory 2612 (AU)

(56) References cited:
WO-A1-2005/083379 **WO-A1-2006/094353**
WO-A1-2007/000323 **WO-A1-2008/011663**
WO-A1-2009/073913 **US-A- 5 774 619**
US-A1- 2004 202 401 **US-A1- 2006 182 832**
US-B1- 6 233 746

(72) Inventors:

- **ARKWRIGHT, John William**
Ryde, NSW 2112 (AU)
- **UNDERHILL, Ian**
Eagle Heights, QLD 4271 (AU)

- **OMARI ET AL.: 'Manometry in the 21st Century: A Novel Fibre Optic Based Technology for Multi-Channel Intraluminal Manometry'**
AMERICAN JOURNAL OF GASTROENTEROLOGY vol. 130, no. A730, 2006, XP008141648

Note: Within nine months of the publication of the mention of the grant of the European patent in the European Patent Bulletin, any person may give notice to the European Patent Office of opposition to that patent, in accordance with the Implementing Regulations. Notice of opposition shall not be deemed to have been filed until the opposition fee has been paid. (Art. 99(1) European Patent Convention).

EP 2 257 780 B1

DescriptionField of the Invention

[0001] The present invention broadly relates to an optical device and relates specifically, though not exclusively, to an optical device for sensing a property.

Background of the Invention

[0002] Optical devices are widely used for sensing different properties. Such optical devices may comprise optical fibres that have sensing regions in which a change in a property causes a change in an optical condition for guiding light in the optical fibres.

[0003] For example, an optical device may be arranged for sensing changes in temperature, strain or pressure and may comprise a Bragg grating which has an optical response that depends on the strain of the Bragg grating. A change in an external pressure or temperature may cause a change in strain of the Bragg grating, which in turn causes a change in a light interference condition. Consequently, the change in external pressure or temperature can be detected by monitoring an optical response of the Bragg grating.

[0004] The optical device may comprise any number of optical fibres with or without Bragg gratings. For example the optical device may comprise a pair of optical fibres. One optical fibre may be arranged for sensing a first property and another property may be arranged for sensing a second property. However, such optical devices having a pair of optical fibres have the disadvantage that mechanical bending flexibility of the device is reduced in a plane in which the optical fibres are positioned.

[0005] US patent publication number US 2006/182832 by Boon Ho discloses a sensing device for monitoring temperature and a sensor in a semiconductor mold. The disclosed device has a first optical fibre portion having a first sensing region and further regions between which the first sensing region is positioned; a first Bragg grating incorporated in a first sensing region; a second optical fibre portion having a second sensing region and further regions between which the second sensing region is positioned; a second Bragg grating incorporated in a second sensing region; at least one member to which the first and second optical fibre portions are attached at the first and second sensing regions; a moveable wall portion coupled to the first Bragg grating so that a movement of the moveable wall portion causes a force that effects a change in an optical period of the first Bragg grating whereby the optical device is arranged for pressure sensing; and wherein the first and second sensing regions are positioned at opposite sides of an area defined between the first and second sensing regions and spaced apart from each other by a first distance and wherein adjacent further regions are spaced apart by a second distance that is smaller than the first distance.

Summary of the Invention

[0006] The present invention provides optical device comprising:

- 5 a first optical fibre portion having a plurality of first sensing regions that are separated by further regions between;
- 10 a first Bragg grating incorporated in each first sensing region;
- 15 a second optical fibre portion having a plurality of second sensing regions that are separated by further regions;
- 20 a second Bragg grating incorporated in each second sensing region;
- 25 at least one member to which the first and second optical fibre portions are attached at the first and second sensing regions;
- 30 moveable wall portion coupled to respective first Bragg gratings so that a movement of the moveable wall portions causes a force that effects a change in strain of the first Bragg grating and thereby effects a change in an optical period of the respective first Bragg grating whereby the optical device is arranged for pressure sensing; and
- 35 wherein respective first and second sensing regions are positioned at opposite sides of an area defined between the first and second sensing regions and wherein at adjacent further regions the first and second optical fibre portions are spaced from each other by a distance that is smaller than that at the respective first and second sensing regions.

The first optical fibre portion may be attached to the at least one member at attachment regions between which the first sensing regions are defined.

[0007] The second optical fibre portion may be attached to the at least one member at attachment regions between which the second sensing regions are defined.

[0008] The at least one member may be a rigid member.

[0009] The first and the second sensing regions may be arranged for sensing the same properties. Alternatively, the first and the second properties may be different properties.

[0010] The optical device may comprise a region in which the distance between the first and second optical fibre portions is decreasing until the optical fibre portions cross each other.

[0011] The invention will be more fully understood from the following description of specific embodiments of the invention. The description is provided with reference to the accompanying drawings.

Brief Description of the Drawings

[0012]

Figure 1 shows an optical system according to a specific embodiment of the present invention, Figures 2 shows an optical device according to an embodiment of the present invention; and Figure 3 (a) - (d) show components of an optical device according to embodiments of the present invention.

Figure 3 (e) shows a non-claimed example.

Detailed Description of Specific Embodiments

[0013] An optical device according to embodiments of the present invention is now described. According to the invention, the optical device is arranged for pressure sensing. However, it is to be appreciated by a person skilled in the art that the device may, as a non-claimed alternative, be arranged for sensing any other properties, such as temperature or strain. Further, the device may be arranged for sensing any number of suitable properties, which may or may not be the same properties. In addition, the optical device may not be arranged for sensing a property.

[0014] Referring initially to Figure 1, a system for pressure sensing is now described. The system 100 comprises a light source 102 which in this embodiment is a broadband light source commonly referred to as a "white" light source even though the light that is emitted by the light source 102 may have any continuous wavelength range. The light is directed via optical circulator 104 to a device for pressure sensing 106. In a variation of this embodiment the circulator 104 may be replaced by an optical coupler, an optical splitter or an optical beam splitter.

[0015] The device 106 may comprise a catheter for insertion into the human body. Further, the device 106 typically comprises an X-ray opaque material or series of x-ray opaque elements, such as a metallic material, for locating the device 106 in the human body.

[0016] In this embodiment the device 106 comprises a plurality of Bragg gratings (not shown) which are formed at least two optical fibres. The Bragg gratings of a first group are arranged so that a change in external pressure results in a change in strain of at least two of the Bragg gratings of the first group. The change in strain causes a change in an optical period of the at least one Bragg grating of the first group, which is detectable by detecting an optical response.

[0017] All Bragg gratings also experience a change in strain in response to a change in temperature. Bragg gratings of a second group of the Bragg gratings are positioned so that a change in external pressure does not result in a change in the optical period which is only affected by a change in temperature. Comparing the responses of Bragg gratings of the first group with that of Bragg gratings of the second group allows obtaining information on changes in the external pressures that is corrected for influences of changes in temperature.

[0018] The light that is produced by the light source 102 and that is directed to the Bragg gratings causes

responses from the Bragg gratings which are directed via the optical circulator 104 to optical analyser 108 for optical analysis. Such a procedure is commonly referred to as wavelength division multiplexing. The Bragg gratings may also effect optical responses which overlap in wavelength or frequency space as long as sufficient information is known about each Bragg grating to allow the signals to be successfully deconvolved.

[0019] Figure 2 shows the device 106 in more detail. The device 106 comprises in this example optical fibres 120 and 122, rigid members 124 and an outer sheath 125. The optical fibres 122 and 120 comprise Bragg gratings 130, 132, 134, 136, 138, and 140. Each rigid member 124 has a movable wall portion which is provided in the form of a diaphragm 142. In this embodiment, the optical fibres 120 and 122 are rigidly connected at attachment regions to respective rigid members 124 so that each Bragg grating 130, 132, 134, 136, 138, and 140 is positioned between two immediately adjacent attachment regions.

[0020] The Bragg gratings 130, 134 and 138 are positioned at a window of a respective rigid member 124 and on, in or near a respective diaphragm 142 such that an external pressure change effects movement of the diaphragm which in turn causes a change in strain of the respective Bragg grating 130, 134 or 138. The change in strain causes a change of an optical property of the Bragg gratings 130, 134 or 138, such as a change of an optical path length, which influences optical responses of the Bragg gratings 130, 134 and 138.

[0021] The Bragg gratings 132, 136 and 140 are positioned so that a change in external pressure will not cause a change in optical response of the Bragg gratings and these Bragg gratings are provided in order to detect local changes in strain that are a result of local changes in temperature. Detected changes in strain of the Bragg gratings 132, 136 and 140 may be used to correct detected changes in strain of the Bragg gratings 130, 134 and 138 for a direct impact of a temperature change on the strain and for an indirect impact by a temperature induced change in elasticity of the diaphragm (using an empirically determined factor that characterises the change in elasticity of the diaphragm as a function of temperature in first order).

[0022] In this example the device 106 is arranged so that each optical fibre comprises Bragg gratings that are exposed to forces resulting from changes in external pressures and Bragg gratings that only experience a change in strain in response to a change in temperature. For example, the optical fibre 120 comprises the Bragg grating 134 that is exposed to external forces and the Bragg gratings 132 and 140 that are not exposed to external forces. In this embodiment the analyser 108 is arranged so that the responses of the Bragg gratings 130, 134 and 138 are compared with those of the Bragg gratings 132, 136 and 140, respectively.

[0023] In this embodiment the optical fibres 120 and 122 are bent so that the optical fibres pass over one an-

other and the rigid members 124 are positioned between locations at which the optical fibres 120 and 122 pass over one another. Because of this particular arrangement of the optical fibres 120 and 122, the mechanical flexibility of the device 106 at the locations at which the optical fibres pass over one another is significantly increased compared to the case of a device comprising two straight and parallel optical fibres. In variations of the described embodiment the optical fibres may not necessarily pass over one another, but may be bent so that a distance between the optical fibres has minima. Further variations will be described below with reference to Figure 3.

[0024] The rigid members 124 are formed from a rigid material, such as silicon, a plastics or metallic material (for example stainless steel, invar, tungsten, or kovar), or any other suitable rigid material. In this embodiment the device 106 comprises six Bragg gratings. In alternative embodiments the device 106 may comprise at least four Bragg gratings at any fixed or variable pitch.

Further it is to be appreciated by a skilled person that each optical fibre 120 and 122 may only comprise one Bragg grating. In addition, the device 106 may only comprise one rigid member and the Bragg gratings of the optical fibres 120 and 122 may both be attached to that rigid member. The device 106 may also comprise more than two optical fibres with Bragg gratings.

In this embodiment the Bragg gratings 130, 134 138 and 132, 136, 140 have a slightly different refractive index variation so that each Bragg grating has an optical response that has a slightly different spectral response.

[0025] As in this embodiment each Bragg grating 130, 134 and 138 causes a different response, it is possible to associate a particular response with a position along the device 106. Consequently, it is possible to perform distributed pressure measurements and detect relative pressure difference between the positions of the Bragg gratings 130, 134 and 138. The combined response from the Bragg gratings is wavelength division multiplexed and the optical analyser 108 uses known wavelength division demultiplexing techniques to identify the responses from the respective grating positions. Suitable software routines are used to determine a pressure or pressure distribution from the optical responses received from the Bragg gratings. Pressure measurements typically include calibrating the device.

[0026] In a variation of this embodiment at least some of the Bragg gratings may be identical and consequently, if the strain conditions are the same, their optical response will also be the same. In this case a pulsed light source may be used to guide light to the Bragg gratings and the positions of the Bragg gratings may be estimated from a time at which the responses are received by the optical analyser 108. Alternatively, a frequency component dependent on the location of each grating may be used to first identify the position of the grating or sensor being interrogated.

[0027] The rigid members 124 together with the diaphragms 142 may each define a closed interior space in

which for example two of the Bragg gratings may be located. Alternatively, the rigid members 124 may comprise openings so that the internal spaces of the rigid members are in fluidal communication with each other.

[0028] Referring to Figure 3, further variations of a device for pressure sensing in accordance with embodiments of the present invention are now described. Figure 3 (a) to (c) shows pairs of optical fibres with Bragg gratings and which may replace the optical fibres 120 and 122 shown in Figure 2.

[0029] Figure 3 (a) shows optical fibres 150 and 152 which are arranged in the same manner as the optical fibres 120 and 122 shown in Figure 2. Figure 3 (b) shows another variation in which optical fibres 154 and 156 pass over one another at two locations between the locations of the Bragg gratings. Figure 3 (c) shows a further variation in which optical fibres 158 and 160 do not pass over one another, but are arranged so that the distance relative to each other has a minimum between the locations of the Bragg gratings. Figure 3 (b) and (c) shows examples in which one of the optical fibres only comprises Bragg gratings that are exposed to external forces caused by changes in external pressures and the other one of the optical fibres only comprises Bragg gratings that are arranged to monitor a change in temperature.

[0030] A person skilled in the art will appreciate that also combinations of the shown variations are within the scope of embodiment of the present invention. For example, the optical fibres may pass over one another at any number of locations and may also be arranged so that at other locations the distance between the optical fibres is reduced without passing over of the optical fibres at these other locations.

[0031] Figure 3 (d) shows another variation of a device for pressure measurement in accordance with an embodiment of the present invention. In this example the device comprises an optical fibre portion 170 that is coupled to optical fibre portions 172 and 174 via an optical y-coupler. The optical fibre portions 172 and 174 comprise Bragg gratings and are coupled to optical fibre portion 176 via a further optical y-coupler. Further, the device comprises optical fibre portions 178 and 180 with Bragg gratings and which re coupled to the optical fibre portion 176 and 182 via additional optical y-couplers. In this embodiment the device has regions that comprise single optical fibre portions (optical fibre portions 170, 176 and 182), and consequently has a relatively large flexibility at these regions.

[0032] The Bragg gratings of the optical fibre portions 172, 174, 178 and 180 may be located in two rigid members, such as rigid members 124 with diaphragms 142 shown in Figure 2, so that Bragg gratings of the optical fibre portions 172 and 178 are exposed to forces resulting from changes in external pressures and the Bragg gratings of the optical fibre portions 174 and 180 are only exposed to changes in strain resulting from temperature changes.

[0033] Although the invention has been described with

reference to particular examples, it will be appreciated by those skilled in the art that the invention may be embodied in many other forms.

Claims

1. An optical device (106) comprising:

a first optical fibre portion (120) having a plurality of first sensing regions that are separated by further regions;

a first Bragg grating (130, 134, 138) incorporated in each first sensing region;

a second optical fibre portion (122) having a plurality of second sensing regions that are separated by further regions;

a second Bragg grating (132, 136, 140) incorporated in each second sensing region;

at least one member (124) to which the first and second optical fibre portions (120, 122) are attached at the first and second sensing regions; and

moveable wall portions (142) coupled to respective first Bragg gratings (130, 134, 138) so that a movement of the moveable wall portions (142) causes a force that effects a change in strain of the respective first Bragg gratings (130, 134, 138) and thereby effects a change in an optical period of the respective first Bragg gratings (130, 134, 138) whereby the optical device (106) is arranged for pressure sensing; **characterised in that**

respective first and second sensing regions are positioned at opposite sides of an area defined between the first and second sensing regions and wherein at adjacent further regions the first and second optical fibre portions are spaced apart from each other by a distance that is smaller than that at the respective first and second sensing regions.

2. The optical device (106) of claim 1 wherein the first optical fibre portion (120) is attached to the at least one member (124) at attachment regions between which the first sensing regions are defined.

3. The optical device (106) of claim 1 or 2 wherein the second optical fibre portion (122) is attached to the at least one member (124) at attachment regions between which the second sensing regions are defined.

4. The optical device of any one of the preceding claims wherein the at least one member (124) is a rigid member.

5. The optical device (106) of any one of the preceding

claims wherein the first and the second sensing regions are arranged for sensing the same properties.

6. The optical device (106) of any one of claims 1 to 4 wherein the first and the second properties are different properties.

7. The optical device (106) of any one of the preceding claims comprising a region in which the distance between the first and second optical fibre portions (120, 122) is decreasing until the optical fibre portions cross each other.

15 Patentansprüche

1. Optische Vorrichtung (106), die Folgendes umfasst:

einen ersten Lichtwellenleiterabschnitt (120), der eine Vielzahl erster Abfühlbereiche aufweist, die durch weitere Bereiche getrennt sind; ein in jedem ersten Abfühlbereich integriertes erstes Bragg-Gitter (130, 134, 138);

einen zweiten Lichtwellenleiterabschnitt (122), der eine Vielzahl zweiter Abfühlbereiche aufweist, die durch weitere Bereiche getrennt sind; ein in jedem zweiten Abfühlbereich integriertes zweites Bragg-Gitter (132, 136, 140);

mindestens ein Element (124), an dem der erste und der zweite Lichtwellenleiterabschnitt (120, 122) an dem ersten und dem zweiten Abfühlbereich befestigt sind; und

bewegliche Wandabschnitte (142), die an jeweilige erste Bragg-Gitter (130, 134, 138) gekoppelt sind, sodass eine Bewegung der beweglichen Wandabschnitte (142) eine Kraft verursacht, die eine Änderung der Dehnung der jeweiligen ersten Bragg-Gitter (130, 134, 138) bewirkt und dadurch eine Änderung einer optischen Periode der jeweiligen ersten Bragg-Gitter (130, 134, 138) bewirkt, wodurch die optische Vorrichtung (106) zum Abfühlen von Druck angeordnet ist; **dadurch gekennzeichnet, dass**

ein jeweiliger erster und zweiter Abfühlbereich auf gegenüberliegenden Seiten eines zwischen dem ersten und dem zweiten Abfühlbereich definierten Gebiets positioniert sind und wobei an benachbarten weiteren Bereichen der erste und der zweite Lichtwellenleiterabschnitt um einen Abstand voneinander beabstandet sind, der kleiner ist als derjenige an dem jeweiligen ersten und zweiten Abfühlbereich.

2. Optische Vorrichtung (106) nach Anspruch 1, wobei der erste Lichtwellenleiterabschnitt (120) an Befestigungsgebieten, zwischen denen die ersten Abfühlbereiche definiert sind, an dem mindestens einen Element (124) befestigt ist.

3. Optische Vorrichtung (106) nach Anspruch 1 oder 2, wobei der zweite Lichtwellenleiterabschnitt (122) an Befestigungsgebieten, zwischen denen die zweiten Abfühlbereiche definiert sind, an dem mindestens einen Element (124) befestigt ist.
4. Optische Vorrichtung nach einem der vorangehenden Ansprüche, wobei es sich bei dem mindestens einen Element (124) um ein starres Element handelt.
5. Optische Vorrichtung (106) nach einem der vorangehenden Ansprüche, wobei die ersten und die zweiten Abfühlbereiche zum Abfühlen derselben Eigenschaften angeordnet sind.
6. Optische Vorrichtung (106) nach einem der Ansprüche 1 bis 4, wobei es sich bei der ersten und der zweiten Eigenschaft um unterschiedliche Eigenschaften handelt.
7. Optische Vorrichtung (106) nach einem der vorangehenden Ansprüche, umfassend einen Bereich, in dem der Abstand zwischen dem ersten und dem zweiten Lichtwellenleiterabschnitt (120, 122) abnimmt, bis die Lichtwellenleiterabschnitte einander kreuzen.

Revendications

1. Dispositif optique (106) comprenant :

une première partie de fibre optique (120) comportant une pluralité de premières régions de détection qui sont séparées par d'autres régions ;
 un premier réseau de Bragg (130, 134, 138) incorporé dans chaque première région de détection ;
 une seconde partie de fibre optique (122) comportant une pluralité de secondes régions de détection qui sont séparées par d'autres régions ;
 un second réseau de Bragg (132, 136, 140) incorporé dans chaque seconde région de détection ;
 au moins un élément (124) auquel les première et seconde parties de fibre optique (120, 122) sont attachées au niveau des premières et secondes régions de détection ; et
 des parties de paroi mobile (142) couplées à des premiers réseaux de Bragg respectifs (130, 134, 138) de telle sorte qu'un mouvement des parties de paroi mobile (142) entraîne une force qui met en oeuvre un changement de contrainte des premiers réseaux de Bragg respectifs (130, 134, 138) et de ce fait met en oeuvre un changement de période optique des premiers réseaux de Bragg respectifs (130, 134, 138),

moyennant quoi le dispositif optique (106) est agencé pour une détection de pression ; **caractérisé en ce que**

des premières et secondes régions de détection respectives sont positionnées au niveau de côtés opposés d'une zone définie entre les premières et secondes régions de détection et dans lequel au niveau d'autres régions adjacentes les première et seconde parties de fibre optique sont espacées l'une de l'autre par une distance qui est inférieure à celle au niveau des premières et secondes régions de détection respectives.

5

10

15

20

25

30

35

40

45

50

55

2. Dispositif optique (106) selon la revendication 1, dans lequel la première partie de fibre optique (120) est attachée à l'au moins un élément (124) au niveau de régions d'attache entre lesquelles les premières régions de détection sont définies.

3. Dispositif optique (106) selon la revendication 1 ou 2, dans lequel la seconde partie de fibre optique (122) est attachée à l'au moins un élément (124) au niveau de régions d'attache entre lesquelles les secondes régions de détection sont définies.

4. Dispositif optique selon l'une quelconque des revendications précédentes, dans lequel l'au moins un élément (124) est un élément rigide.

5. Dispositif optique (106) selon l'une quelconque des revendications précédentes, dans lequel les premières et les secondes régions de détection sont agencées pour détecter les mêmes propriétés.

6. Dispositif optique (106) selon l'une quelconque des revendications 1 à 4, dans lequel les premières et les seconds propriétés sont des propriétés différentes.

7. Dispositif optique (106) selon l'une quelconque des revendications précédentes, comprenant une région dans laquelle la distance entre les première et seconde parties de fibre optique (120, 122) diminue jusqu'à ce que les parties de fibre optique se croisent.

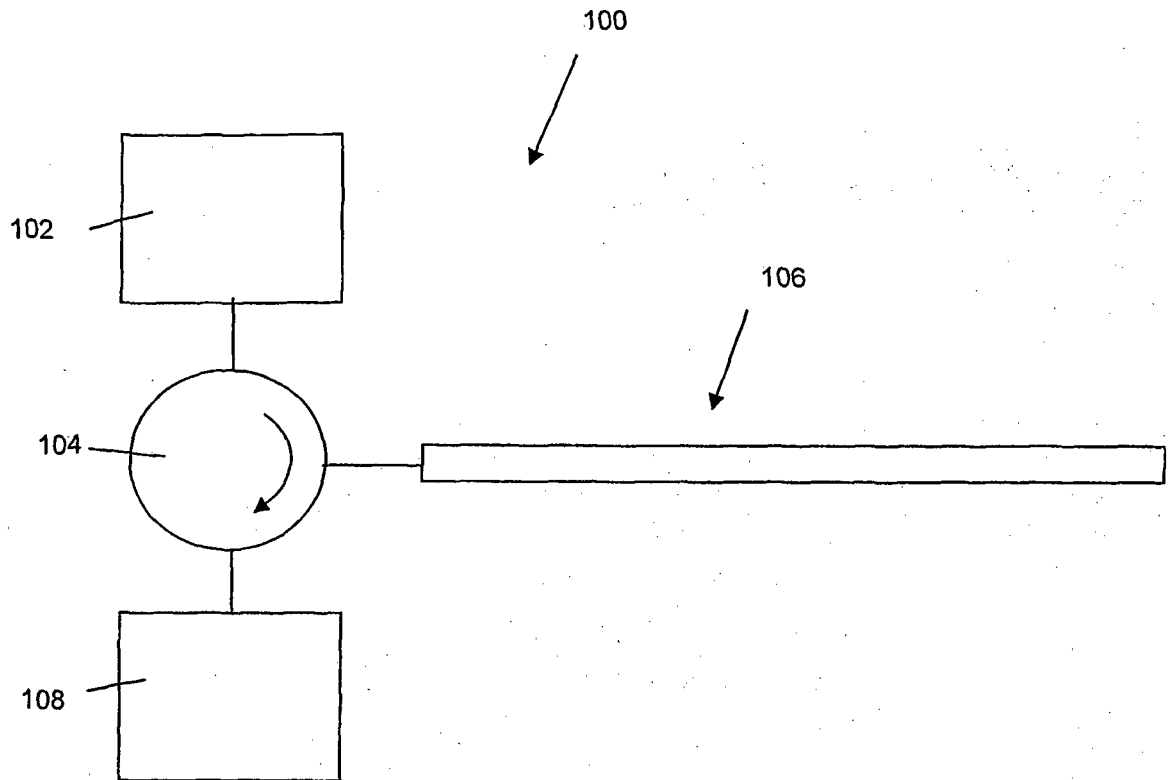

Fig. 1

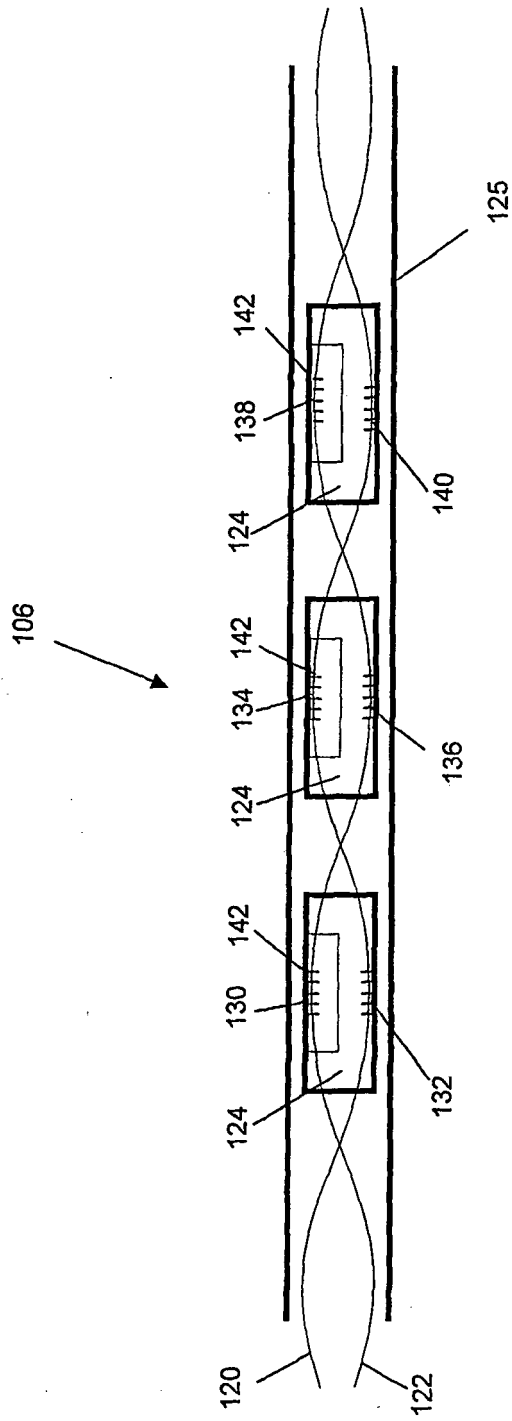

Fig. 2

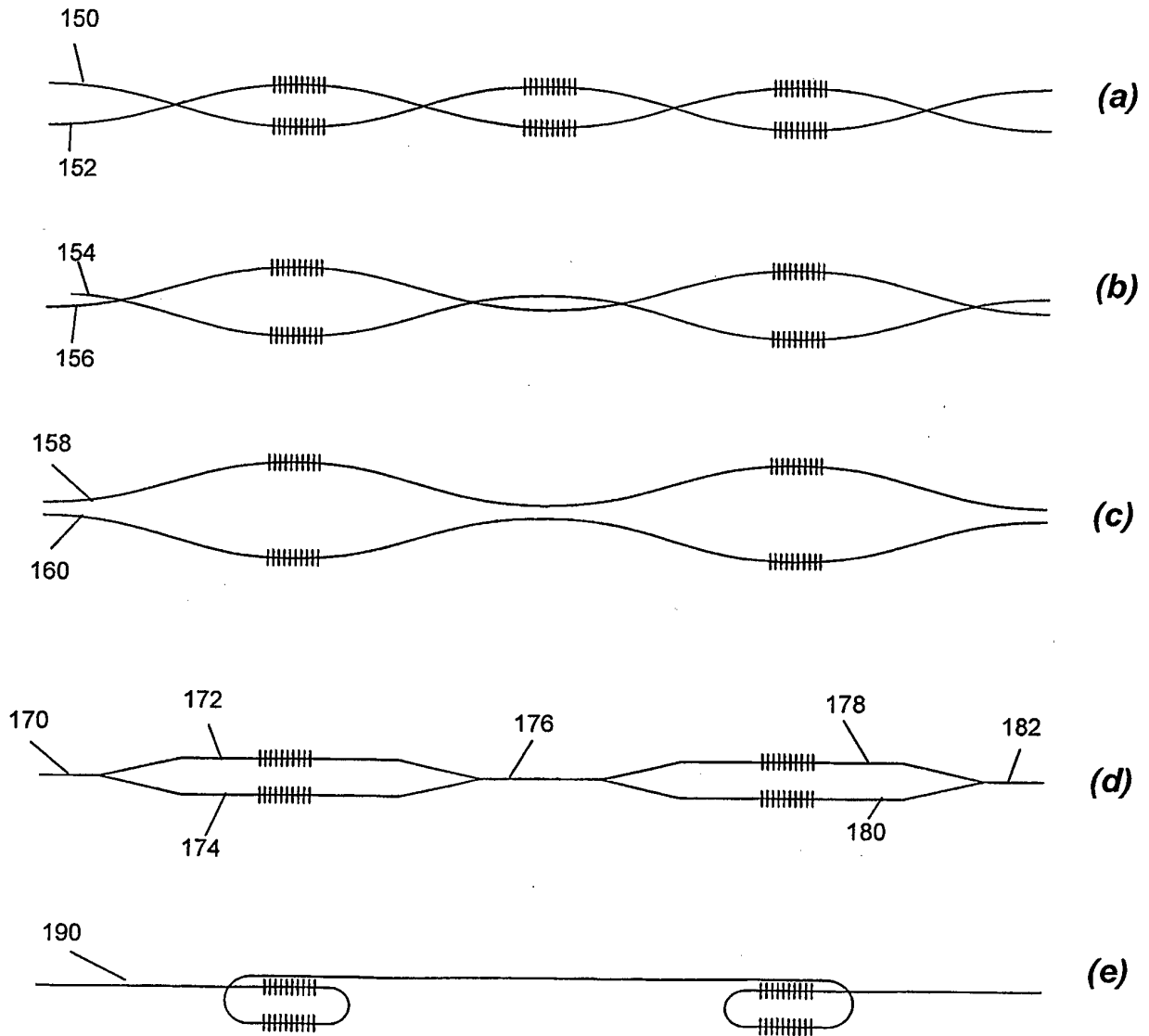

Fig. 3

REFERENCES CITED IN THE DESCRIPTION

This list of references cited by the applicant is for the reader's convenience only. It does not form part of the European patent document. Even though great care has been taken in compiling the references, errors or omissions cannot be excluded and the EPO disclaims all liability in this regard.

Patent documents cited in the description

- US 2006182832 A, Boon Ho [0005]

专利名称(译)	光学设备		
公开(公告)号	EP2257780B1	公开(公告)日	2016-05-04
申请号	EP2009719900	申请日	2009-03-11
[标]申请(专利权)人(译)	联邦科学和工业研究组织		
申请(专利权)人(译)	联邦科学与工业研究组织		
当前申请(专利权)人(译)	联邦科学与工业研究组织		
[标]发明人	ARKWRIGHT JOHN WILLIAM UNDERHILL IAN BLENMAN NEIL		
发明人	ARKWRIGHT, JOHN WILLIAM UNDERHILL, IAN BLENMAN, NEIL		
IPC分类号	G01L1/24 G01L11/02 G02B27/44 A61B5/00 G02B6/00 G01L9/00 G01D5/353		
CPC分类号	A61B5/01 A61B5/02154 A61B5/036 A61B6/12 A61B2562/0247 A61B2562/0266 A61B2562/0271 G01D5/35316 G01D5/35387 G01L1/246 G01L9/0077 G02B6/2932 G01D5/353 G01L1/243 G01L1/247 G02B6/124		
优先权	2008901137 2008-03-11 AU		
其他公开文献	EP2257780A4 EP2257780A1		
外部链接	Espacenet		

摘要(译)

本公开提供了一种光学装置，其包括具有第一区域的第一光纤部分以及位于第一区域之间的其他区域。光学装置还包括第二光纤部分，该第二光纤部分具有第二区域和位于第二区域之间的其他区域。此外，光纤包括至少一个构件，第一和第二光纤部分在第一和第二区域处连接到该构件。第一和第二区域位于在第一和第二区域之间限定的区域的相对侧，并且彼此间隔开第一距离，并且其中相邻的另外的区域间隔开小于第一距离的第二距离。

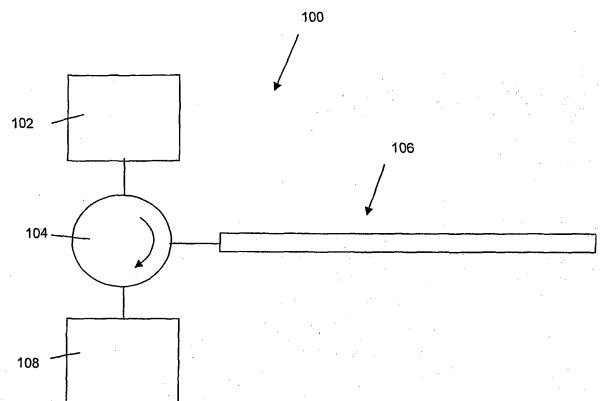

Fig. 1