

(19)



(11)

EP 2 241 033 B1

(12)

EUROPEAN PATENT SPECIFICATION

(45) Date of publication and mention of the grant of the patent:
14.06.2017 Bulletin 2017/24

(51) Int Cl.:
H04B 13/00 (2006.01) A61B 5/00 (2006.01)

(21) Application number: **08865831.5**

(86) International application number:
PCT/IB2008/055413

(22) Date of filing: **18.12.2008**

(87) International publication number:
WO 2009/081343 (02.07.2009 Gazette 2009/27)

(54) **ELECTRODE DIVERSITY FOR BODY-COUPLED COMMUNICATION SYSTEMS**

ELEKTRODENDIVERSITÄT FÜR KÖRPERGEKOPPELTE KOMMUNIKATIONSSYSTEME

DIVERSITÉ D'ÉLECTRODE POUR DES SYSTÈMES DE COMMUNICATION COUPLÉS AU CORPS

(84) Designated Contracting States:
AT BE BG CH CY CZ DE DK EE ES FI FR GB GR HR HU IE IS IT LI LT LU LV MC MT NL NO PL PT RO SE SI SK TR

- **VAN DEN HOMBERG, Johannes**
NL-5656 AE Eindhoven (NL)
- **FAZZI, Alberto**
NL-5656 AE Eindhoven (NL)

(30) Priority: **20.12.2007 EP 07123774**

(74) Representative: **Kroeze, Johannes Antonius**
Philips Intellectual Property & Standards
High Tech Campus 5
5656 AE Eindhoven (NL)

(43) Date of publication of application:
20.10.2010 Bulletin 2010/42

(73) Proprietor: **Koninklijke Philips N.V.**
5656 AE Eindhoven (NL)

(56) References cited:
WO-A-2006/132058 WO-A-2007/148877
JP-A- 2003 143 086 JP-A- 2003 188 833

(72) Inventors:
• **SCHENK, Tim Corneel Wilhelmus**
NL-5656 AE Eindhoven (NL)

EP 2 241 033 B1

Note: Within nine months of the publication of the mention of the grant of the European patent in the European Patent Bulletin, any person may give notice to the European Patent Office of opposition to that patent, in accordance with the Implementing Regulations. Notice of opposition shall not be deemed to have been filed until the opposition fee has been paid. (Art. 99(1) European Patent Convention).

Description

FIELD OF THE INVENTION

5 **[0001]** The present invention relates to a coupler device, processing apparatus and method of processing a plurality of body-coupled communication signals.

BACKGROUND OF THE INVENTION

10 **[0002]** Body coupled communications (BCC) or body-based communication has been proposed as a promising alternative to radio frequency (RF) communication as a basis for body area networks. BCC allows exchange of information between a plurality of devices which are at or in close proximity of a body of a human or an animal. This can be achieved by capacitive or galvanic coupling of low-energy electrical fields onto the body surface. Hence, the human body is exploited as a communication channel, so that communication can take place with much lower power consumption than in standard radio systems commonly used for body area networks (BANs, e.g. ZigBee or Bluetooth systems). Since BCC is usually applied in close proximity to the body, it can be used to realize new and intuitive body-device interfaces based on contact or proximity.

15 **[0003]** BCC can be technically realized by electric fields that are generated by a small body-worn tag, e.g., being integrated into a credit card or another suitable device attached to or worn in close proximity to the body. This tag capacitively or galvanically couples a low-power signal to the body. Sometimes this body-coupled communication is referred to as "near-field intra-body communication". BCC is a wireless technology that allows electronic devices on and near the human body to exchange digital information through capacitive or galvanic coupling. Information is transmitted by modulating electric fields and either capacitively or galvanically coupling tiny currents in the range of pico amperes onto the body. The body conducts the tiny current (e.g., 50 pA) to body mounted receivers. The environment (the air and/or earth ground) provides a return path for the transmitted signal.

20 **[0004]** Figs. 1A and 1B show a general transmitter-receiver model of capacitive BCC, as described in Thomas Guthrie Zimmerman, Personal Area Networks (PAN): Near-Field Intra-Body Communication. Master of Thesis, Massachusetts Institute of Technology, September 1995. Both TX and RX elements are electronic battery powered devices, electrically isolated and having a pair of electrodes A and B, acting as reference and signal electrode. The transmitter and receiver electrodes A, B can be modelled as capacitor plates. Such capacitive BCC can be used for data exchange between devices in so-called personal area networks (PANs) or body area networks (BANs). A PAN prototype working at 330 kHz was developed to demonstrate the digital exchange of data through the body. Examples of such communication systems are disclosed for example in US6.992.565, US6.777.992, US6.223.018, and US5.914.701.

25 **[0005]** The electrodes A, B can be made of common printed circuit board (PCB) material with copper surfaces. The size could be approximately 3 cm x 5 cm x 1 cm. Measurements have shown reliable communication over the whole human body, regardless of the location of both TX and RX devices.

30 **[0006]** Although the devices Figs. 1A and 1B have good sensitivity and give a strong signal even when the TX and RX devices are far apart on the body, the orientation of the RX/TX devices with respect to the human body is critical and largely influences the communication performance. For capacitive BCC, ideally, the TX and RX devices are lying flat on the body surface, with one electrode in close contact to the body and the other having "free sight" to the surroundings.

35 **[0007]** This is the case since the performance of capacitive BCC is influenced by a capacitive coupling between the transmitter (TX) and receiver (RX) devices and the human body and all surrounding conductors. In this scenario the most critical aspect is represented by the orientation of the devices with respect to the body. The signal attenuation strongly depends on the ratio between the capacitive coupling to human body of the signal electrodes and reference electrodes. The closer the coupling values the weaker the received/transmitted signal. A solution to this problem is crucial in order to have reliable communication between BCC devices that are not fixed to the human body but that can be also loosely placed around it, as in most of the possible scenarios.

40 **[0008]** In Fig. 1A both TX and RX devices are in a flat angle with respect to the human body. Electrodes B have thus a much stronger capacitance C_{2b} to the body than to the surroundings (capacitance C_{1b}), while electrodes A are better coupled to the surroundings (capacitance C_{1a}) and have only small coupling to the body (capacitance C_{2a}). This way a signal that is applied between the TX electrodes will generate a voltage difference between the electrodes in the receiver, thereby enabling data transfer.

45 **[0009]** However, in Fig. 1B, the RX device is rotated by 90 degrees, which means that both electrodes A and B of the RX device have equal coupling to the body (capacitance $C_{2a}=C_{2b}$) and surroundings (capacitance $C_{1a}=C_{1b}$). As a result, any signal that is conducted by the body (as for instance a signal generated by the TX device) is common mode for electrodes A and B in the RX device. In other words, both electrodes A and B see the same potential and there is no voltage difference. The same holds for situations where the TX device is rotated by 90 degrees. In that case no signal is provided to the body and signal transfer is impossible. Of course, the 90 degree angle is a limit situation, but it will be

clear that any other rotation (with respect to the ideal flat angle) will lead to a decrease of the received signal power.

[0010] In order to provide close contact and flat angle to the human body, it has been proposed to fix electrodes to the body (e.g. by means of stickers or elastic bands) but this puts a strong limit on the possible applications, since in most scenarios the TX/RX devices are expected to be only in proximity to the body and loosely coupled to it (e.g. any device that could be placed in pocket, such as a mobile phone, or be integrated in textile). Moreover also in the case of devices that can be stitched to the human body (for example, medical sensors), movements of the user during normal life can affect the capacitance configuration of the transmitting/receiving devices in a way that reliable communication cannot be guaranteed.

[0011] Communications using BCC is thus sensitive to the orientation of the couplers relative to the body. Due to this sensitivity to the orientation of the couplers, the user is required to place and keep the BCC devices in a well-defined orientation. This creates user-inconvenience and unreliable transmission. Hence, it is desirable to make the BCC communication between devices which can be placed somewhere at the body reliable, so that the communication range for these devices is the whole body.

[0012] International Patent Application published under No. WO2006/132058 A1 discloses a communication device which includes an electrode control section of the communication device adapted to check statuses of static coupling of an electrode with the surroundings.

[0013] International Patent Application published under No. WO2007/148877 A1 is an application filed before this application but published only after discloses a communication device using the human body as a transmission medium which determines an arrangement direction of signal electrodes and ground electrodes according to a signal transmission direction.

SUMMARY OF THE INVENTION

[0014] An object of the present invention is to increase robustness and user convenience in body-coupled or body-based communication systems.

[0015] This object is achieved by a coupler device as claimed in claim 1, an apparatus as claimed in claim 5, and a method as claimed in claim 16.

[0016] Accordingly, an adaptive configuration system is provided, so that, within a group of electrodes, the most suited electrodes for acting as signal electrodes (e.g. the ones with better than average coupling to the human body) and the most suited electrodes to act as reference electrodes (e.g. the ones with a lower than average coupling to the human body) can be selected. In this way, it is possible to substantially improve conditions under which the communication system operates, regardless of the position or orientation of transmission/reception devices with respect to the human body. The orientation sensitivity of the body-coupled communication can thus be reduced and robustness and user convenience can be increased. Multiple or segmented electrodes with mutual orientation difference are provided on or close to the body. This electrode diversity can then be applied to either select an electrode for a certain transmission or to combine signals from different couplers. In a specific embodiment the signals from the different couplers can be combined using a weighting sum.

[0017] Hence, a concept of electrode diversity, techniques to combine or select signals from the different electrodes, different methods to determine selection or combining parameters and a signaling method to allow for joint transmission and reception coupler diversity can be provided.

[0018] The electrodes could be configured in any number, in any shape, or can be arranged in any geometry. Thereby, the system is capable of selecting a desirable set of electrodes to be used as signal electrodes or as reference electrodes. Similarly, the combining parameters can be determined to combine the signals from the different electrodes. In these ways an electrode configuration with enhanced reception power or quality can thus be obtained for a given position and orientation with respect to the body, so that optimized and reliable communication can be achieved.

[0019] The electrode configuration can be statically (only at start-up) or dynamically (continuously or periodically) selected according to the application scenario. The selection of the configuration can be based e.g. on a capacitance estimation and can be controlled by hardware or software. The system and communication is then much less influenced by position, orientation or movements with respect to the human or animal body.

[0020] Additionally, the number of electrodes used as a reference or as signal couplers may be optimized. For example, if a small number of electrodes are enough to enable a correct coupling of the signal to the body, all the other electrodes can be selected as reference electrodes. This provides further optimization since capacitive coupling of the reference electrode(s) to surrounding conductors (earth ground) is one of the parameters that determine signal strength. The more capacitive coupling the stronger the signal.

[0021] The plurality of electrodes or electrode segments of the electrode arrangements may be arranged to provide during said body-coupled communication at least one of a horizontal orientation between signal and reference electrodes or electrode segments with respect to the surface of the human or animal body, a vertical orientation between signal and reference electrodes or electrode segments with respect to the surface of the human or animal body, and a signal-

only orientation in which said electrode arrangement only consists of signal electrodes, and wherein said plurality of electrodes or electrode segments differ by at least one of orientation and location to an extent sufficient to achieve said coupler diversity. Thereby, a high variety of orientations of individual electrodes or electrode segments can be provided, so that receipt of at least one strong signal is highly probable.

5 **[0022]** In a specific example, the plurality of electrodes or electrode segments may be arranged in a three-dimensional arrangement, which may further increase the diversity gain.

[0023] Furthermore, the plurality of electrodes or electrode segments may comprise first electrodes with a first conducting area and second electrodes with a second conducting area, said first conducting area having a bigger size than said conducting area. With this arrangement the electrode with the smaller conducting area can be used as a capacitor measurement electrode.

10 **[0024]** According to a first option, the estimation can be performed locally by determining at least one of a capacitance or a resistance between coupler electrodes through which the body-coupled communication signals have been received.

[0025] According to a second option, the estimation can be performed based on a training sequence received via a body-coupled communication signal. In a specific example, the estimation can be adapted to receive the training sequence in a preamble of a packet of the body-coupled communication signal.

15 **[0026]** According to a third option, the estimation can be performed based on a received data signal of the body-coupled communication signal. More specifically, the estimator may be adapted to estimate the transmission parameters, selection parameters or weighting parameters based on an error check of the received data signal.

[0027] The transmission parameters may be successively adapted for each of the plurality of body-coupled communication signals by using the selecting processing.

20 **[0028]** Moreover, a look-up table may be provided for storing estimated transmission parameters of body-coupled devices from which the plurality of body-coupled communication signals have been received.

[0029] Additionally, the estimated transmission parameters may be signaled back to body-coupled devices from which the plurality of body-coupled communication signals have been received.

25 **[0030]** The signal processing unit of the above apparatus may comprise a plurality of multipliers for selectively weighting the plurality of received body-coupled communication signals, and an adder for adding the weighted body-coupled communication signals.

30 **[0031]** As an alternative, the signal processing unit may comprise a plurality of comparators for comparing the strength of each of the plurality of body-coupled communication signals with an average strength or other threshold level, and a plurality of switches for selecting those body-coupled communication signals whose signal strength is higher than the average strength or other threshold to be combined to generate the output signal.

[0032] Further advantageous embodiments are defined below.

BRIEF DESCRIPTION OF THE DRAWINGS

35 **[0033]** The invention will now be described, by way of example, based on embodiments with reference to the accompanying drawings, wherein:

Figs. 1A and 1B show schematic human bodies and the influence of device orientation on the coupling capacitors;

40 Figs. 2A to 2C show electrode coupling setups with different reference and signal electrode orientations;

Fig. 3 shows an electrode arrangement with electrode diversity according to an embodiment;

Fig. 4 shows a functional implementation of a diversity combiner according to an embodiment;

Fig. 5 shows a schematic data packet for a training-based estimation of weighting parameters;

Fig. 6 shows a flow diagram of an estimation procedure according to an embodiment;

45 Figs. 7 shows an example of a multiple-electrode arrangement according to an embodiment;

Figs. 8A and 8B shows examples of splitted electrodes according to embodiments; and

Fig. 9 shows a schematic diagram of a control circuit for controlling an electrode arrangement according to an embodiment.

DESCRIPTION OF PREFERRED EMBODIMENTS

50 **[0034]** Various embodiments of the present invention will now be described based on a BCC system as an alternative to radio frequency (RF) communication for PANs and BANs. As already mentioned above, BCC signals are conveyed over the body instead of through the air. As such, the communication is confined to an area close to body, in contrast to RF communications, where a much larger area is covered. Therefore, TX and RX devices are situated on, connected to, or placed close to the body. This creates possibilities for many applications in the field of identification and security. Moreover, since lower frequencies can be applied than in RF communications, it opens the door to low-cost and low-power implementations of BAN/PAN. Data signals are not transmitted by antennas but using "couplers", consisting of

e.g. electrodes. These couplers are configured to couple, e.g. galvanic or capacitive, the data signals to the body.

[0035] Figs. 2A to 2C show possible electrode configurations for a BCC communication between a TX device and an RX device. More specifically, a communication setup over an arm is illustrated, where information is transmitted from the TX device to the RX device.

[0036] Fig. 2A shows a first coupling setup, where both signal level (S) and reference or ground level (GND) are placed close to or on the body and in this way both couple to the body. The corresponding electrodes of the couplers are configured to obtain a horizontal field orientation and is most often used for galvanic coupling. Fig. 2B shows a second coupling setup, where either the signal level (S) or the reference or ground level (GND) is coupled to the body, while the respective other level is coupled to the "air", "surroundings" or "earth ground". This second coupling setup provides a vertical field orientation and is most often used for capacitive coupling. The structure connected to the body consists of two isolated coupling electrodes, where one has to be directed towards the body and the other one is stacked parallel to it. Fig. 2C shows a third coupling setup where only one coupler is connected to or placed close to the body, but where a ground plate (GND) of a PCB of the RX/TX devices may act as reference or ground electrode. The latter configuration is most often used for capacitive BCC.

[0037] Instead of using only two electrodes (e.g. one that couples the signal to the body and one that is used as a reference) for the communication system, shown in Figs. 1A and 1B as a pair of plates or electrodes A and B, a set of plates or electrodes (which can be in any number or shape) is provided in various embodiments. The set of electrodes is connected to an active configuration apparatus or system which selects which electrodes are coupled to the human body in order to use at least some of them as signal electrodes (e.g. in parallel), while at least some of the remaining electrodes are then used as reference electrode (e.g. also in parallel).

[0038] According to the embodiments described below, it is suggested to improve reliability, robustness and ease of use of BCC systems by applying electrode diversity with at least one of different orientations of the electrodes, different techniques to either combine the signals at the different electrodes or group and/or select (a subset of) them to create electrode diversity, and different procedures to determine a desired diversity setting, i.e., criteria or parameter(s) based on which diversity setting (e.g. selection of a coupler) can be controlled. As an additional option, a specific signaling could be applied from a receiver (RX device) to a transmitter (TX device) to allow the transmitter to apply or control its diversity setting based on measurements or determinations at the receiver.

[0039] The coupling configurations presented in Figs. 2A to 2C are disadvantageous in that their performance is sensitive to the orientation of the coupler. In K. Fujii, et al., "Study on the Transmission Mechanism for Wearable Device Using the Human Body as a Transmission Channel," IEICE Trans Commun E88-B, pp. 2401-2410, it is indicated that the orientation shown in Fig. 2A has a 20 dB higher loss than when the electrodes are rotated by 90 degrees. Similar things are indicated for the coupling configurations shown in Figs. 2B and 2C. For Fig. 2B it is indicated that when the couplers, i.e. pair of electrodes, are tilted, compared to the body, the received signal level largely degrades, as was explained in the above discussion of Fig. 1B. It has also been shown that the performance is best when the GND reference electrode faces the ground.

[0040] According to embodiments of the present invention, orientation sensitivity is decreased by subdividing the electrode into smaller, separate electrodes or, similarly, providing additional electrodes compared to the setups presented in Figs. 2A to 2C. The signals on the different electrodes are then combined and/or selected in such a way that for a given orientation of the body or electrode configuration maximum performance is achieved.

[0041] Fig. 3 illustrates a possible diversity setup for the horizontal orientation of Fig. 2A. In this setup a receiver (RX) 10 comprises three additional signal electrodes 40 (e.g. plates or the like) compared to the original setup, wherein the signal electrodes 40 and a reference electrode 42 (colored in black and providing the GND signal) are connected to a selecting and/or combining unit 30 (which may be a hardware circuit or element or a software routine and which may be arranged as a separate unit or as a part of the receiver 10). Based on some acquired measures of performance or parameters, described later, the receiver 10 decides which electrode(s) 40 to use for reception of a data signal (i.e. selection) and/or how to combine the signals originating from a transmitter (TX) 20 and received by the different electrodes 40 (i.e. combination), and controls the selecting and/or combining unit 30 based on its decision. It is noted that for the purpose of illustration in Fig. 3, the reference electrode 42 is chosen to be fixed. However, in the selection diversity case, a pair of electrodes could be selected as well. Then, the present exemplary case of five electrodes 40 yields ten possible combinations instead of four with the fixed GND reference electrode 42. Alternatively, also different grouping of a set of electrodes as reference and another set of electrodes as signal electrodes could be achieved using this setup.

[0042] Moreover, the transmitter 20 not necessarily has to be a fixed electrode arrangement in Fig. 2. Rather, it could also be equipped with a similar diversity setup as the receiver 10. In this case, a pair of transmitter electrodes could be selected before transmission of the data signal, based on some performance or parameter measurement. In some coupler configuration it might be beneficial to do a joint optimization of the settings of the transmitter 20 and the receiver 10.

[0043] For the other coupler configurations of Figs. 2B and 2C, different diversity setups can be made, which have similar properties to the setup in Fig. 3. For the vertical orientation of Fig. 2B, both signal and GND electrodes 40, 42 can be split in multiple separate electrodes which are separately connected to the selecting and/or combining unit 30.

Moreover, such electrodes could be placed on a different angle, which reduces the impact of a certain orientation of the total device. An example could be a segmented bracelet, consisting of different electrode pairs. In such a configuration always at least one GND electrode is facing the surroundings or the ground and could be selected.

[0044] In the following, for clarity, the coupler setup of Fig. 3 will be considered for illustration purposes, although the measures and features are also applicable to the other scenarios.

[0045] Fig. 4 shows a schematic functional diagram of a possible implementation of the selecting and/or combining unit 30. A received signal y obtained at the output of the combining and/or selecting unit 30, can be expressed as:

$$y = \sum_i \alpha_i x_i + \alpha_g g \quad (1)$$

where x_i and α_i respectively denote the voltage of and weighting value for the i th electrode. The variable g denotes the GND reference voltage and the corresponding weight α_g would have an opposite sign to that for the other electrodes. For the selection combining approach α_i equals 1 for the selected signal electrode i_{select} and 0 for all others signal electrodes and consequently $\alpha_g = -1$. Note that also a subset can be selected by setting $\alpha_i = 1$ for a set $\{i_{\text{select},1}, i_{\text{select},2}, \dots\}$ and $\alpha_g = -1$. The signals x_i and g are weighted by the respective multipliers 44 and then summed up by an adder 46 to obtain the output y .

[0046] In Fig. 3, four signal electrodes 40 and one GND electrode or reference couples 42 are provided. It is noted that for selection combining at least some of the multipliers 44 can be substituted by switches. For cases where also the reference electrode 42 is selected, the expression for the received signal becomes:

$$y = \sum_i \alpha_i x_i, \quad (2)$$

where α_i equals "1" for the selected signal electrodes and α_i equals "-1" for the selected reference electrodes and "0" for all others.

[0047] A procedure to determine i for the selection is based on maximizing the received voltage, i.e.,

$$i_{\text{select}} = \arg \max_i (|x_i - g|) = \arg \max_i (|x_i|). \quad (3)$$

[0048] Similarly for cases where both the signal electrodes 40 and the reference electrode 42 can be selected from a set of electrodes, wherein the set index equals:

$$(i, j)_{\text{select}} = \arg \max_{i, j} (|\sum_i \alpha_i x_i - \sum_j \alpha_j x_j|) \text{ for } i \neq j. \quad (4)$$

[0049] Another approach could be to base the decision of selection on an interference level of the signals from the different signal electrodes 40, e.g. by estimating the received power during the time no messages are transmitted.

[0050] Of course, when it is the goal to minimize the communication range of the proposed solution, for privacy and security reasons, a electrode or electrode pair which results in a desired or target signal quality (e.g. signal-to-noise ratio (SNR)) could be selected, rather than just the one with the highest possible signal quality.

[0051] Furthermore, instead of selecting one (or two) of the signal electrodes 40, the signals from different plates could be selected, which provides the advantage that the whole area of the electrode setup is applied. In that case, the weights in equations (1) and (2) are the relative weights of the different voltage contributions. A simple to implement solution would be to add all the signals with equal weight, i.e., $\alpha_i = 1$ for all i . A more optimum solution is $\alpha_i = 1/\text{SNR}_i$, where SNR_i denotes the instantaneous signal-to-noise ratio for i th electrode connection.

[0052] When complex signals (I and Q) are used for body-coupled transmission, the received signal on the i th electrode can be written as:

$$x_i = \beta_i \exp(-j\theta_i)t, \quad (5)$$

where j denotes the complex unit, t denotes the transmitted (complex) signal and β_i and θ_i denote the amplitude and phase of the channel between the TX electrode and the i th RX electrode, respectively. In this case, a good way to determine the weights is based on maximum-ratio combining, i.e., $\alpha_i = \beta_i \exp(j\theta_i)$. A less complex method is based on equal gain combining, which yields $\alpha_i = \exp(j\theta_i)$, i.e., the signals from the different electrodes 40, 42 are coherently added.

[0053] Different methods to combine and select the signals (voltages) from the different electrodes 40, 42 have been described above. In the following, possible approaches for estimating the weighting parameters α_i or other parameters are presented. These approaches comprise for example offline estimation, training-based estimation, and data-aided parameter estimation.

[0054] For offline estimation, parameters can be estimated locally in the transmitter and/or receiver to determine the set of weighting coefficients $\{\alpha_i\}$. No transmission of data or training signal(s) is required. Several methods of offline estimation are described later, where for the case of capacitive coupling to the body the effective capacitance between pairs of electrodes is determined experimentally. Alternatively, in cases where the electrodes are galvanically coupled to the body, the resistance between the electrodes can be determined.

[0055] For selection combining, $\alpha_{i,j}=1$ is set where the capacitance is lowest and the resistance is highest, similarly to equations (1) and (2). For other diversity schemes, a function $f(\cdot)$ exists, which maps the capacitance and resistance values $C_{i,j}$ and $R_{i,j}$ to the weighting values $\alpha_{i,j}$, i.e.,

$$\alpha_{i,j} = f(C_{i,j}, R_{i,j}). \quad (6)$$

[0056] An example could be $\alpha_{i,j} = C_{i,j}^{-n}$, or $\alpha_{i,j} = R_{i,j}^n$, where $n = 1$ or 2 .

[0057] The advantage of offline estimation is that it can be applied during the periods when the system is not transmitting or receiving data and, thus, processing power is available. Also, it can be applied even where the transmitter and receiver are not in communication range.

[0058] For training-based estimation, a known sequence or training sequence is transmitted to enable estimation of the weighting parameters. This could be a separate packet which is transmitted to assess the body channel, also referred to as a "sounding packet". However, the preamble part of a packet transmission could be used also.

[0059] Fig. 5 shows a schematic data packet for a training-based estimation of the weighting or selection parameters. A preamble 50 is included in a packet transmission with a data portion 52, anyway, to enable synchronization and, as such, does not impose a large additional overhead. The preamble 50 may often consist of repeated symbols and can be used in this embodiment to convey the training sequence. Typical parameters, which would be estimated in such a procedure, are β_i , θ_i and SNR_i .

[0060] Fig. 6 shows a flow diagram of a procedure for estimating RX parameters, according to an embodiment.

[0061] In step S110, the receiver 10 uses the first symbols of the preamble 50 to get into synchronization. Subsequently, in step S120, performance parameters are measured on the different electrodes 40, e.g. one-by-one, to obtain estimated performance parameters. This can be enabled by setting $\alpha_i=1$ for only one i . At the symbol boundary the receiver 10 switches to the next electrode by setting $\alpha_{i+1}=1$ and $\alpha_i=0$. As such, the parameters corresponding to the different electrodes are successively estimated. In step S130, just before the data is received, the estimated parameters, e.g., β_i and θ_i , are used to set the weighting parameters α_i to the correct values for the reception of data.

[0062] It is noted that for many i values or a big number of (i,j) , a large overhead is required (i.e. a long preamble) to estimate all parameters. This overhead can, however, considerably be reduced by storing the parameters of previous packets. Then, when the time constants of the channel are low compared to the packet repetition rate, only the parameters for a subset of the RX electrodes 40 have to be estimated per packet.

[0063] For data-aided parameter estimation, a received and/or detected data signal is used to estimate the parameters. Based on a detected symbol, the amplitude β_i and phase θ_i of the channel can be determined, e.g., based on the following equation:

$$\hat{\beta}_i \exp(-j\hat{\theta}_i) = \hat{t}^{-1} x_i, \quad (7)$$

where \hat{t} is the estimate of the transmission signal derived from the detected data. Another approach could be to base the selected electrode(s) on a cyclic redundancy check (CRC) of the packet. When this check shows that the packet is detected incorrectly, the receiver 10 may switch to another electrode. An advantage of this method is that no extra overhead is required.

[0064] In this case of a coupler diversity at the transmitter side, two signaling methods can be applied alone or in combination, namely using the reciprocity of the body channel or using feedback of the channel parameters.

[0065] In the first signaling method, all BCC devices act as a transceiver, i.e., have both transmitter and receiver

functionalities. Furthermore, reciprocity of the body channel is used, which means that the channel from a first device to a second device is equal to that from the second device to the first device. The transmitter can thus use the parameters, e.g., β_i , θ_i and SNR_i , estimated during a receiving phase (from the same device) to determine the values of the weighting parameters α_j . These parameters can be based on either one of the above estimation methods.

5 **[0066]** For this first signaling method, the transceiver could be equipped with a look-up table storing the previous estimated parameters for all other devices. This number will, however, be low for BANs, since the number of nodes on a human or animal body will be limited.

10 **[0067]** In the second signaling method, the receiver estimates the channel parameters and after detection of the data part of the packet, it transmits these estimated values back to the sources (i.e. transmitter sides), which can apply them for the following transmission. Alternatively, the receiver can determine the α_i values for the transmitter and feed those back. In this way the receiver can optimize jointly for the TX and RX, which will lead to an improved performance. To enable this estimation process for different TX configurations, the transmitter can switch between coupler plates within the preamble period, e.g., every preamble symbol is transmitted by another electrode.

15 **[0068]** The proposed transmission system is thus capable of selecting a set of electrodes to be used as signal electrodes or as reference electrodes. The proposed system may consist of a set of electrodes that are supposed to be connected to a BCC device, a sensing circuit or functionality that, following different principles provides information about the capacitance between one single electrode and the rest of the world, a configuration controller or functionality that, based on the information provided by the sensing circuit or functionality, decides which electrodes should be considered as a coupler to the human body and which ones should be considered as transmitting electrodes (couplers to the external surroundings, e.g. earth ground). In the exemplary arrangement of Fig. 3, the sensing and configuration functionality may be provided by the selecting and/or combining unit 30.

20 **[0069]** Fig. 7 shows an example of a multiple-electrode arrangement according to an embodiment. In general, the electrodes can be of any shape, any size and can be arranged in any geometrical configuration. Nevertheless, geometries that provide a three-dimensional (3D) distribution of the electrodes, such as the arrangement of Fig. 7 provide a high probability of selecting two sets of electrodes with largely different aggregate capacitance to the human body, which is beneficial for capacitive based BCC.

25 **[0070]** A solution to find the optimal arrangement could be to simply try all (or a set of) different electrode arrangements and determine which one is best. As described above, this could be achieved via communication with another receiver or transmitter or by switching the device in a transmission mode and measure the current consumption in the output driving buffer. The electrode configuration that gives the lowest current consumption is the optimal one, as it makes sure that all electrodes with a large capacitance to the body are grouped together, providing good coupling to the body. All other electrodes apparently have a small capacitance to the body, which means that they must have "free sight" to the surroundings so that they can be grouped together as a combined transmitting surface. When the circumstances change, e.g. when the orientation of the device changes, an old configuration could be used, even when transmission is lost, until a new sweep through all different electrode arrangements is performed. Such a sweep could thus be performed regularly.

30 **[0071]** Figs. 8A and 8B show examples of electrode arrangements according to other embodiments where each electrode A1 to A4 is split into two conductors, e.g., one big conductor to be used as a BCC electrode 40 for the BCC communication and one small conductor to be used as a measurement node 43 for capacitance measurement. The conductors can be of any shape and size.

35 **[0072]** With this arrangement, the capacitive coupling between the BCC electrode 40 and its corresponding sensing or measurement electrode 43 is strongly influenced by the presence of conductor surfaces in the environment. If an isolated conducting surface (as the human body) is close to the electrode, the capacitance between the BCC electrode 40 and the measurement electrode 43 increases. This difference can be easily sensed by applying a known signal to the BCC electrode 40 and evaluating the amplitude of the signal at the measurement electrode 43. This operation can be performed in parallel or serial for all electrodes belonging to the BCC signal. Moreover, the measurement could be performed during standard operation, by using a frequency band different with respect to the one used for signalling, or could be performed just before the beginning of a transmission or reception phase, or could be performed on a periodic base (determined by the desired application).

40 **[0073]** Once the capacitance measurement has been performed, it is easy to sort the electrodes into groups, e.g., those electrodes that show a higher capacitance to external conductors are the one that are selected as couplers to the human body, i.e. signal electrodes, and the other electrodes are those that are selected as reference electrodes.

45 **[0074]** With this topology it is also easy to adapt the number of electrodes that belong to the various groups. The mean capacitance value to the body can be estimated and for example each electrode that shows a capacitance larger than the mean value can be selected as electrode to the human body, while the other electrode(s) should be selected as electrodes to the environment. In this case, only the electrodes that give a major contribution to the capacitive coupling to the human body are selected as signal electrodes, even if their number is small.

50 **[0075]** Fig. 9 shows a schematic diagram of a control circuit topology for controlling an electrode arrangement according

to an embodiment.

5 [0076] The capacitance between a BCC electrode and its corresponding measurement electrode is a measure for the distance between that electrode 220 and a conducting (e.g. human-) body. The capacitance can be measured by applying a known signal to the electrode and measuring the amplitude of the resulting signal at the measurement electrode with a predetermined load. This load is shown in Fig. 9 as a resistor to a common voltage V_C , but in principle any impedance, e.g. a capacitor, a coil or combination thereof can be used. Also, in the embodiment from Fig. 9 the known signal is derived directly from a modulated input transmission signal supplied to a buffer amplifier 210 with non-inverted and inverted outputs. This is possible due to the fact that the amplitude of the inverted transmission signal at the inverted output is equal to that of the original transmission signal, which means that the output of each amplitude detector 230 is independent of the position of a corresponding input switch S_i . Of course, it is also possible to use an extra, independent signal source, at an out-of-band frequency, to provide the known measurement signal. The output of each amplitude detector 230 is buffered at a buffer 240 to obtain a DC voltage V_i which represents the signal strength and which is connected via equal resistors R_i to R_{i+n} to a summing node, giving the average voltage V_{avg} of all individual V_i voltages. Each branch has a comparator 250 which determines whether the individual voltage V_i is higher or lower than the average voltage V_{avg} , and based on this decision the corresponding electrode is connected via switch S_i to either the transmission signal or the inverted transmission signal. Thereby, all electrodes that show a higher than average capacitance (close to the body) will be grouped and connected to one phase of the transmission signal, while all others will be connected to the opposite phase of the transmission signal.

10 [0077] It is however noted that the configuration of Fig. 9 is only an example of how the system can be built. An equivalent setup could also be obtained with different building blocks or, after an analog-to-digital (A/D) conversion, in the digital domain and thus also on the basis of software routines.

15 [0078] During transmission the proposed configuration will be immediately and continuously altered when the conditions (e.g. orientation of the device) change. During a receiving mode, the last configuration of a prior transmission mode can be used, or an out-of-band signal can be applied to all electrodes, which should not affect the in-band received signals but allows continuous adaptation of the electrode arrangement.

20 [0079] The above embodiments can be implemented as adaptive body-coupled or body-based systems in many domains. In the field of consumer electronics, wireless connections can be set up more easily. As the number of available electronic devices increases (home computer, laptop, pocket pc, mobile phone ...) the interaction between these devices becomes more and more arduous to set up for common users. As facilitating tool BCC systems can help to connect several different devices using heterogeneous platforms and protocols. For example, with BCC a Bluetooth connection between a laptop and a mobile phone can be set-up by simple touch of the two devices allowing e.g. a photo exchange application.

25 [0080] BCC can also be used to realize applications which provide more convenience in the automotive area. Examples are car entry where a car can be opened by just touching it, theft protection, which allows only operating the car for specified users, wearing an identification tag, car configuration/personalization, which takes away the burden from the user to adjust the car settings to his/her personal preferences, the user is immediately recognized when entering the car.

30 [0081] Moreover, automatic identification is increasingly required in medical applications, both to improve patient safety, and workflow efficiency. Patient identifiers based on body-coupled communication allow for automatic recognition of patients during medical examinations, safe & automatic association of devices, sensors and wireless measurements to individual patients.

35 [0082] In all the above fields of application, the solution described in the above embodiments significantly increases reliability of the body channel communication.

40 [0083] In summary, a coupler device, processing apparatus and method of processing a plurality of body-coupled communication signals which have been detected by using an electrode arrangement with a plurality of electrodes or electrode segments have been described. Respective transmission parameters of the body-coupled communication signals are estimated and at least one of a selecting, grouping and weighting processing is applied to the detected body-coupled communication signals based on the estimated transmission parameters. Then, the processed body-coupled communication signals are combined to generate a diversity output signal.

45 [0084] While the invention has been illustrated and described in detail in the drawings and the foregoing description, such illustration and description are to be considered illustrative or exemplary and not restrictive. The invention is not limited to the disclosed embodiments. From reading the present disclosure, other modifications will be apparent to persons skilled in the art. Such modifications may involve other features which are already known in the art and which may be used instead of or in addition to features already described herein.

50 [0085] Variations to the disclosed embodiments can be understood and effected by those skilled in the art, from a study of the drawings, the disclosure and the appended claims. In the claims, the word "comprising" does not exclude other elements or steps, and the indefinite article "a" or "an" does not exclude a plurality of elements or steps. A single processor or other unit may fulfill the functions of the selecting and/or combining unit 30, e.g. as described in connection with Figs. 4 and 6, based a corresponding software routines. The computer program may be stored/distributed on a

suitable medium, such as an optical storage medium or a solid-state medium supplied together with or as part of other hardware, but may also be distributed in other forms, such as via the Internet or other wired or wireless telecommunication systems. The mere fact that certain measures are recited in mutually different dependent claims does not indicate that a combination of these measures cannot be used to advantage. Any reference signs in the claims should not be construed as limiting the scope thereof.

Claims

1. An apparatus for processing a plurality of body-coupled communication signals detected by an electrode arrangement with a plurality of electrodes or electrode segments, said apparatus (30) comprising:

- a) a plurality of input terminals adapted to receive said plurality of body-coupled communication signals;
- b) an estimator adapted to estimate respective transmission parameters of said body-coupled communication signals; and
- c) a signal processor adapted to apply at least one of a selecting and weighting processing to said received body-coupled communication signals and to combine the processed body-coupled communication signals to generate a diversity output signal, wherein said selecting and weighting processing is controlled based on said estimated transmission parameters

wherein said signal processing unit comprises a plurality of multipliers (44) adapted to selectively weight said plurality of received body-coupled communication signals, and an adder (46) adapted to add the weighted body-coupled communication signals.

2. The apparatus according to claim 1, wherein said estimator is adapted to perform one of the following actions :

- estimate said transmission parameters locally by determining at least one of a capacitance or a resistance between coupler electrodes through which said body-coupled communication signals have been received,
- estimate said transmission parameters based on a training sequence received via a body-coupled communication signal,
- receive said training sequence in a preamble (50) of a packet of said body-coupled communication signal,
- estimate said transmission parameters based on a received data signal of said body-coupled communication signal,
- estimate said transmission parameters based on an error check of said received data signal, and
- estimate said transmission parameters successively for each of said plurality of body-coupled communication signals by using said selecting processing.

3. The apparatus according to claim 1, wherein said apparatus comprises a look-up table for storing estimated transmission parameters of body-coupled devices from which said plurality of body-coupled communication signals have been received.

4. The apparatus according to claim 1, wherein said apparatus comprises a transmitter for transmitting the estimated transmission parameters back to body-coupled devices from which said plurality of body-coupled communication signals have been received.

5. The apparatus according to claim 1, wherein said signal processing unit comprises a plurality of comparators (250) for comparing the strength of each of said plurality of body-coupled communication signals with a predetermined threshold, and a plurality of switches (S_i) for selecting those body-coupled communication signals whose signal strength is higher than said predetermined threshold to be combined to generate said output signal.

6. A body coupled communication arrangement comprising the apparatus of claim 1 and a coupler device for a body-coupled communication, said coupler device being configured to be placed at or in close proximity to a human or animal body and comprising an electrode arrangement consisting of a plurality of electrodes or electrode segments (40, 42; 40, 43) adapted to be separately connectable to achieve electrode diversity, said plurality of electrodes or electrode segments (40, 42; 40, 43) being arranged to provide during said body-coupled communication at least one of a horizontal orientation between signal and reference electrodes or electrode segments with respect to the surface of said human or animal body, a vertical orientation between signal and

reference electrodes or electrode segments with respect to the surface of said human or animal body, and a signal-only orientation in which said electrode arrangement only consists of signal electrodes, and wherein said plurality of electrodes or electrode segments (40, 42; 40, 43) differ by at least one of orientation and location to an extent sufficient to achieve said electrode diversity.

5

7. The body coupled communication arrangement according to claim 6, wherein said plurality of electrodes or electrode segments (40, 42; 40, 43) are arranged in a three-dimensional arrangement.

10

8. The body coupled communication arrangement according to claim 6, wherein said plurality of electrodes or electrode segments (40, 43) comprise first electrodes (40) with a first conducting area and second electrodes (43) with a second conducting area, said first conducting area having a bigger size than said conducting area.

9. A method of processing a plurality of body-coupled communication signals, said method comprising:

15

a) detecting body-coupled communication signals by using an electrode arrangement with a plurality of electrodes or electrode segments (40, 42; 40, 43);

b) estimating respective transmission parameters of said body-coupled communication signals; and

c) applying based on said estimated transmission parameters at least one of a selecting and weighting processing to said received body-coupled communication signals and combining the processed body-coupled communication signals to generate a diversity output signal,

20

wherein said selecting and weighting processing comprises receiving a plurality of body-coupled communication signals, and adding the weighted body-coupled communication signals.

25

10. The method according to claim 9, further comprising performing said estimating locally by determining at least one of a capacitance or a resistance between respective ones of said coupler electrodes or electrode segments, through which said body-coupled communication signals have been received.

30

11. The method according to claim 9, further comprising estimating said transmission parameters based on a training sequence received via a body-coupled communication signal.

12. The method according to claim 9, further comprising estimating said transmission parameters based on a received data signal of said body-coupled communication signal.

35

13. The method according to claim 9, further comprising estimating said transmission parameters successively for each of said plurality of body-coupled communication signals by using said selecting processing.

14. The method according to claim 9, further comprising signaling the estimated transmission parameters back to body-coupled devices from which said plurality of body-coupled communication signals have been received.

40

15. A computer program product comprising code means for executing the steps of a method as claimed in one of claims 9 to 14.

45

Patentansprüche

1. Vorrichtung zur Verarbeitung einer Vielzahl von körpergekoppelten Kommunikationssignalen, die von einer Elektrodenanordnung mit mehreren Elektroden oder Elektrodensegmenten detektiert werden, wobei die Vorrichtung (30) umfasst:

50

a) mehrere, zum Empfang der Vielzahl von körpergekoppelten Kommunikationssignalen geeignete Eingangsanschlüsse;

b) eine Schätzfunktion, die so eingerichtet ist, dass sie jeweilige Übertragungsparameter der körpergekoppelten Kommunikationssignale schätzt; sowie

55

c) einen Signalprozessor, der so eingerichtet ist, dass er zumindest eine Auswahl- oder Gewichtungsverarbeitung auf die empfangenen, körpergekoppelten Kommunikationssignale anwendet und die verarbeiteten, körpergekoppelten Kommunikationssignale kombiniert, um ein Diversitäts-Ausgangssignal zu erzeugen, wobei die Auswahl- und Gewichtungsverarbeitung aufgrund der geschätzten Übertragungsparameter gesteuert wird,

EP 2 241 033 B1

wobei die Signalverarbeitungseinheit mehrere Multiplizierer (44), die so eingerichtet sind, dass sie die Vielzahl von empfangenen, körpergekoppelten Kommunikationssignalen selektiv wichten, sowie einen Addierer (46) umfasst, der so eingerichtet ist, dass er die gewichteten, körpergekoppelten Kommunikationssignale addiert.

- 5 **2.** Vorrichtung nach Anspruch 1, wobei die Schätzfunktion so eingerichtet ist, dass sie einen der folgenden Schritte ausführt, wonach sie:
- die Übertragungsparameter lokal schätzt, indem sie zumindest eine Kapazität oder einen Widerstand zwischen Koppel Elektroden ermittelt, durch welche die körpergekoppelten Kommunikationssignale empfangen wurden,
 - 10 - die Übertragungsparameter aufgrund einer über ein körpergekoppeltes Kommunikationssignal empfangenen Trainingssequenz schätzt,
 - die Trainingssequenz in einer Präambel (50) eines Pakets des körpergekoppelten Kommunikationssignals empfängt,
 - die Übertragungsparameter aufgrund eines empfangenen Datensignals des körpergekoppelten Kommunikationssignals schätzt,
 - 15 - die Übertragungsparameter aufgrund einer Fehlerprüfung des empfangenen Datensignals schätzt, und
 - die Übertragungsparameter für jedes der Vielzahl von körpergekoppelten Kommunikationssignalen unter Anwendung der Auswahlverarbeitung schätzt.
- 20 **3.** Vorrichtung nach Anspruch 1, wobei die Vorrichtung eine Zuordnungstabelle zur Speicherung geschätzter Übertragungsparameter von körpergekoppelten Einrichtungen umfasst, von denen die Vielzahl körpergekoppelter Kommunikationssignale empfangen wurde.
- 25 **4.** Vorrichtung nach Anspruch 1, wobei die Vorrichtung einen Sender umfasst, um die geschätzten Übertragungsparameter zurück zu körpergekoppelten Einrichtungen zu übertragen, von denen die Vielzahl körpergekoppelter Kommunikationssignale empfangen wurde.
- 30 **5.** Vorrichtung nach Anspruch 1, wobei die Signalverarbeitungseinheit mehrere Komparatoren (250) zum Vergleichen der Stärke von jedem der Vielzahl körpergekoppelter Kommunikationssignale mit einem vorher festgelegten Schwellenwert sowie mehrere Schalter (S_i) umfasst, um solche körpergekoppelten Kommunikationssignale auszuwählen, deren Signalstärke höher als der vorher festgelegte Schwellenwert ist, um diese zur Erzeugung des Ausgangssignals zu kombinieren.
- 35 **6.** Körpergekoppelte Kommunikationsanordnung mit der Vorrichtung nach Anspruch 1 sowie einer Kopplereinrichtung für eine körpergekoppelte Kommunikation, wobei die Kopplereinrichtung so konfiguriert ist, dass sie an einem menschlichen Körper oder Tierkörper oder in unmittelbarer Nähe desselben platziert wird und eine Elektrodenanordnung umfasst, die aus mehreren Elektroden oder Elektrodensegmenten (40, 42; 40, 43) besteht, die so ausgeführt sind, dass sie getrennt anschließbar sind, um eine Elektrodendiversität zu erreichen,
- 40 wobei die mehreren Elektroden oder Elektrodensegmente (40, 42; 40, 43) so angeordnet sind, dass sie während der körpergekoppelten Kommunikation zumindest eine horizontale Ausrichtung zwischen Signal und Referenzelektroden oder Elektrodensegmenten gegenüber der Oberfläche des menschlichen Körpers oder Tierkörpers, eine vertikale Ausrichtung zwischen Signal und Referenzelektroden oder Elektrodensegmenten gegenüber der Oberfläche des menschlichen Körpers oder Tierkörpers oder eine Nur-Signal-Ausrichtung vorsehen, in welcher die Elektrodenanordnung nur aus Signalelektroden besteht, und wobei sich die mehreren Elektroden oder Elektrodensegmente (40, 42; 40, 43) in einem Ausmaß, das ausreicht, um die Elektrodendiversität zu erreichen, durch zumindest Ausrichtung oder Positionierung voneinander unterscheiden.
- 45 **7.** Körpergekoppelte Kommunikationsanordnung nach Anspruch 6, wobei die mehreren Elektroden oder Elektrodensegmente (40, 42; 40, 43) in einer dreidimensionalen Anordnung angeordnet sind.
- 50 **8.** Körpergekoppelte Kommunikationsanordnung nach Anspruch 6, wobei die mehreren Elektroden oder Elektrodensegmente (40, 43) erste Elektroden (40) mit einem ersten leitenden Bereich sowie zweite Elektroden (43) mit einem zweiten leitenden Bereich umfassen, wobei der erste leitende Bereich größere als der zweite leitende Bereich ist.
- 55 **9.** Verfahren zur Verarbeitung einer Vielzahl von körpergekoppelten Kommunikationssignalen, wobei das Verfahren die folgenden Schritte umfasst, wonach:
- a) körpergekoppelte Kommunikationssignale unter Verwendung einer Elektrodenanordnung mit mehreren Elek-

troden oder Elektrosegmenten (40, 42; 40, 43) detektiert werden;
b) jeweilige Übertragungsparameter der körpergekoppelten Kommunikationssignale geschätzt werden; und
c) aufgrund der geschätzten Übertragungsparameter zumindest eine Auswahl- oder Gewichtungsverarbeitung auf die empfangenen, körpergekoppelten Kommunikationssignale angewendet wird und die verarbeiteten, körpergekoppelten Kommunikationssignale kombiniert werden, um ein Diversitäts-Ausgangssignal zu erzeugen,

wobei die Auswahl- und Gewichtungsverarbeitung das Empfangen einer Vielzahl von körpergekoppelten Kommunikationssignalen sowie das Addieren der gewichteten, körpergekoppelten Kommunikationssignale beinhaltet.

10. Verfahren nach Anspruch 9, wonach weiterhin die Schätzung lokal durchgeführt wird, indem zumindest eine Kapazität oder ein Widerstand zwischen jeweiligen Koppel Elektroden oder Elektrosegmenten ermittelt wird, durch welche die körpergekoppelten Kommunikationssignale empfangen wurden.

11. Verfahren nach Anspruch 9, wonach weiterhin die Übertragungsparameter aufgrund einer über ein körpergekoppeltes Kommunikationssignal empfangenen Trainingssequenz geschätzt werden.

12. Verfahren nach Anspruch 9, wonach weiterhin die Übertragungsparameter aufgrund eines empfangenen Datensignals des körpergekoppelten Kommunikationssignals geschätzt werden.

13. Verfahren nach Anspruch 9, wonach weiterhin die Übertragungsparameter für jedes der Vielzahl von körpergekoppelten Kommunikationssignalen unter Anwendung der Auswahlverarbeitung sukzessiv geschätzt werden.

14. Verfahren nach Anspruch 9, wonach weiterhin die geschätzten Übertragungsparameter zurück zu körpergekoppelten Einrichtungen übertragen werden, von denen die Vielzahl körpergekoppelter Kommunikationssignale empfangen wurde.

15. Computerprogrammprodukt mit Codemitteln zur Ausführung der Schritte eines Verfahrens nach einem der Ansprüche 9 bis 14.

Revendications

1. Appareil pour traiter une pluralité de signaux de communication couplés au corps détectés par un agencement d'électrodes ayant une pluralité d'électrodes ou de segments d'électrode, ledit appareil (30) comprenant :

a) une pluralité de bornes d'entrée adaptées pour recevoir ladite pluralité de signaux de communication couplés au corps ;

b) un estimateur adapté pour estimer les paramètres de transmission respectifs desdits signaux de communication couplés au corps ; et

c) un processeur de signaux adapté pour appliquer au moins l'un d'un traitement de sélection et de pondération auxdits signaux de communication couplés au corps reçus et pour combiner les signaux de communication couplés au corps traités pour générer un signal de sortie de diversité, dans lequel ledit traitement de sélection et de pondération est contrôlé sur la base desdits paramètres de transmission estimés,

dans lequel ladite unité de traitement de signaux comprend une pluralité de multiplicateurs (44) adaptés pour pondérer sélectivement ladite pluralité de signaux de communication couplés au corps reçus, et un sommateur (46) adapté pour ajouter les signaux de communication couplés au corps pondérés.

2. Appareil selon la revendication 1, dans lequel ledit estimateur est adapté pour effectuer l'une des actions suivantes :

- estimer lesdits paramètres de transmission localement en déterminant au moins l'une d'une capacité ou d'une résistance entre des électrodes de couplage par le biais desquelles lesdits signaux de communication couplés au corps ont été reçus,

- estimer lesdits paramètres de transmission sur la base d'une séquence d'apprentissage reçue via un signal de communication couplé au corps,

- recevoir ladite séquence d'apprentissage dans un préambule (50) d'un paquet dudit signal de communication couplé au corps,

- estimer lesdits paramètres de transmission sur la base d'un signal de données reçu dudit signal de commu-

nication couplé au corps,

- estimer lesdits paramètres de transmission sur la base d'une vérification d'erreur dudit signal de données reçu, et

- estimer lesdits paramètres de transmission successivement pour chacun de ladite pluralité de signaux de communication couplés au corps au moyen dudit traitement de sélection.

5

3. Appareil selon la revendication 1, dans lequel ledit appareil comprend une table de consultation pour stocker les paramètres de transmission estimés de dispositifs couplés au corps desquels ladite pluralité de signaux de communication couplés au corps ont été reçus.

10

4. Appareil selon la revendication 1, dans lequel ledit appareil comprend un émetteur pour émettre les paramètres de transmission estimés en retour vers les dispositifs couplés au corps desquels ladite pluralité de signaux de communication couplés au corps ont été reçus.

15

5. Appareil selon la revendication 1, dans lequel ladite unité de traitement de signaux comprend une pluralité de comparateurs (250) pour comparer l'intensité de chacun de ladite pluralité de signaux de communication couplés au corps à un seuil prédéterminé, et une pluralité de commutateurs (S_i) pour sélectionner les signaux de communication couplés au corps dont l'intensité de signal est supérieure audit seuil prédéterminé pour qu'ils se combinent pour générer ledit signal de sortie.

20

6. Agencement de communication couplé au corps comprenant l'appareil selon la revendication 1 et un dispositif de couplage pour une communication couplée au corps, ledit dispositif de couplage étant configuré pour être placé au niveau d'un corps humain ou animal ou à proximité étroite de celui-ci et comprenant un agencement d'électrodes constitué d'une pluralité d'électrodes ou de segments d'électrode (40, 42 ; 40, 43) adapté(s) pour pouvoir se connecter séparément pour obtenir une diversité d'électrodes, ladite pluralité d'électrodes ou de segments d'électrode (40, 42 ; 40, 43) étant agencé(e)s pour fournir pendant ladite communication couplée au corps au moins l'une d'une orientation horizontale entre les électrodes ou segments d'électrode de signal et de référence par rapport à la surface dudit corps humain ou animal, une orientation verticale entre les électrodes ou segments d'électrode de signal ou de référence par rapport à la surface dudit corps humain ou animal, et une orientation signal uniquement dans laquelle ledit agencement d'électrodes est uniquement constitué d'électrodes de signal, et dans lequel ladite pluralité d'électrodes ou de segments d'électrode (40, 42 ; 40, 43) diffèrent d'au moins l'une de l'orientation et de la localisation dans une mesure suffisante pour obtenir ladite diversité d'électrodes.

25

30

35

7. Agencement de communication couplé au corps selon la revendication 6, dans lequel ladite pluralité d'électrodes ou de segments d'électrode (40, 42 ; 40, 43) sont agencé(e)s selon un agencement tridimensionnel.

40

8. Agencement de communication couplé au corps selon la revendication 6, dans lequel ladite pluralité d'électrodes ou de segments d'électrode (40, 43) comprend des premières électrodes (40) ayant une première zone conductrice et des secondes électrodes (43) ayant une seconde zone conductrice, ladite première zone conductrice ayant une taille plus grande que ladite seconde zone conductrice.

9. Procédé de traitement d'une pluralité de signaux de communication couplés au corps, ledit procédé comprenant :

45

a) la détection de signaux de communication couplés au corps au moyen d'un agencement d'électrodes ayant une pluralité d'électrodes ou de segments d'électrode (40, 42 ; 40, 43) ;

b) l'estimation de paramètres de transmission respectifs desdits signaux de communication couplés au corps ; et

c) l'application sur la base desdits paramètres de transmission estimés d'au moins l'un d'un traitement de sélection et de pondération auxdits signaux de communication couplés au corps reçus et la combinaison des signaux de communication couplés au corps reçus pour générer un signal de sortie de diversité,

50

dans lequel ledit traitement de sélection et de pondération comprend la réception d'une pluralité de signaux de communication couplés au corps, et l'ajout des signaux de communication couplés au corps pondérés.

55

10. Procédé selon la revendication 9, comprenant en outre la mise en oeuvre de ladite estimation locale en déterminant au moins l'une d'une capacité ou d'une résistance entre lesdites électrodes ou lesdits segments d'électrode de couplage respectifs, par le biais desquel(le)s lesdits signaux de communication couplés au corps ont été reçus.

EP 2 241 033 B1

11. Procédé selon la revendication 9, comprenant en outre l'estimation desdits paramètres de transmission sur la base d'une séquence d'apprentissage reçue via un signal de communication couplé au corps.

5 12. Procédé selon la revendication 9, comprenant en outre l'estimation desdits paramètres de transmission sur la base d'un signal de données reçu dudit signal de communication couplé au corps.

10 13. Procédé selon la revendication 9, comprenant en outre l'estimation desdits paramètres de transmission successivement pour chacun de ladite pluralité de signaux de communication couplés au corps au moyen dudit traitement de sélection.

14. Procédé selon la revendication 9, comprenant en outre la signalisation des paramètres de transmission estimés en retour vers les dispositifs couplés au corps desquels ladite pluralité de signaux de communication couplés au corps ont été reçus.

15 15. Produit de programme informatique comprenant des moyens de code pour exécuter les étapes d'un procédé selon l'une des revendication 9 à 14.

20

25

30

35

40

45

50

55

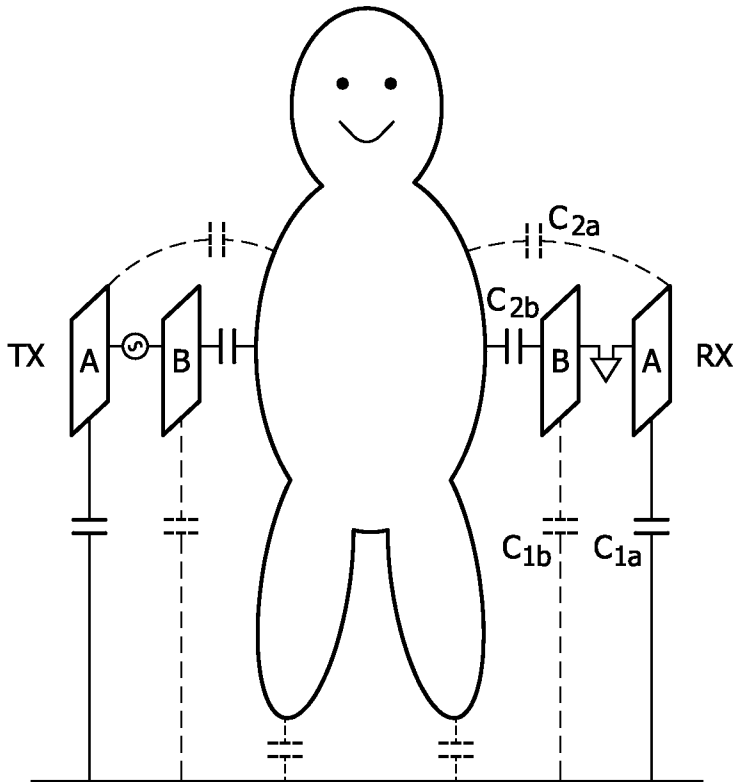

FIG. 1A

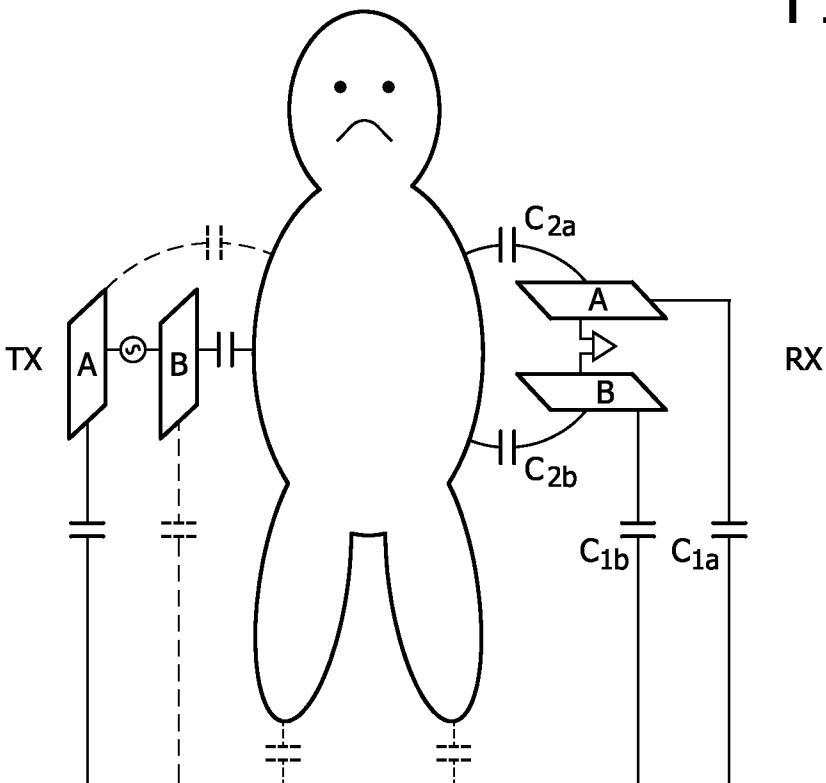

FIG. 1B

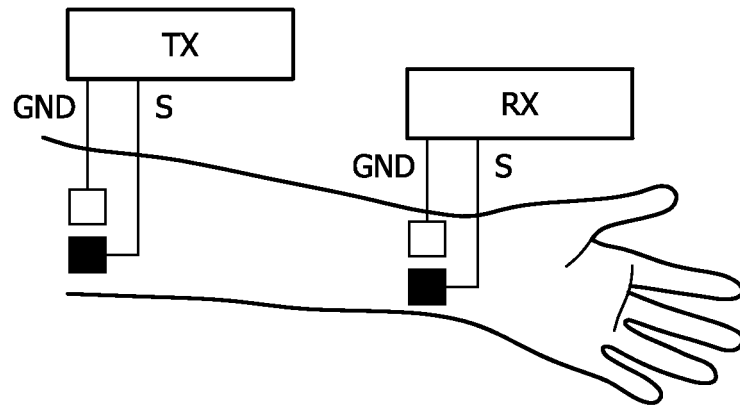

FIG. 2A

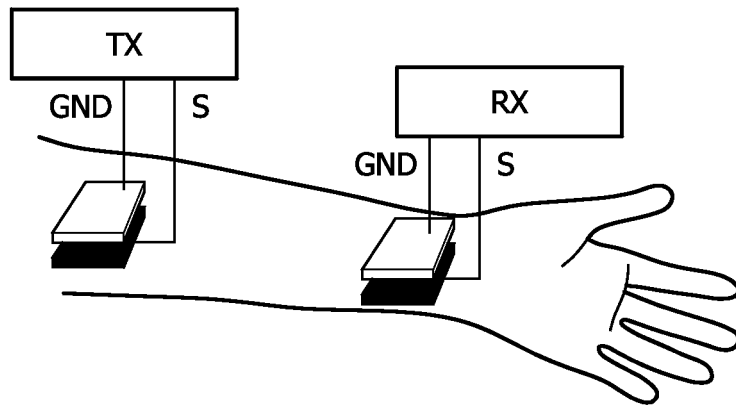

FIG. 2B

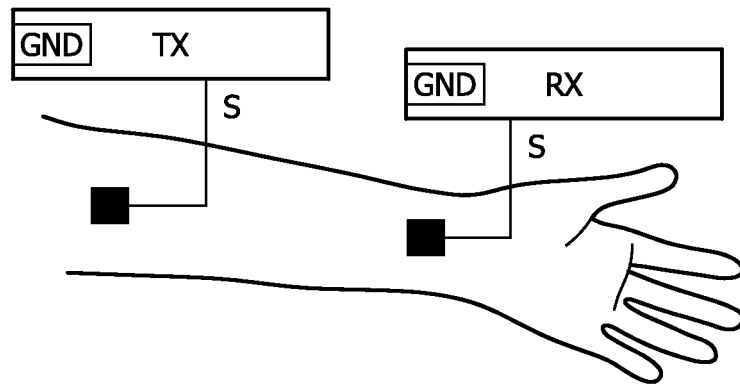

FIG. 2C

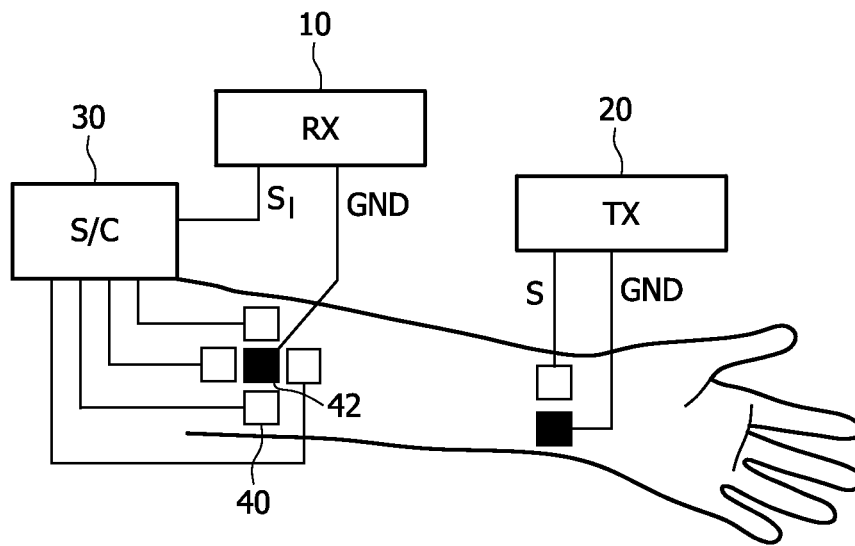

FIG. 3

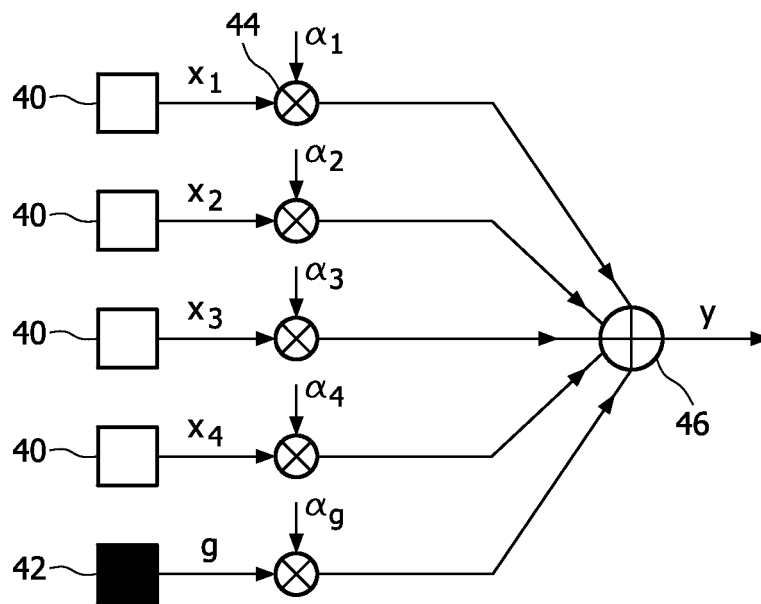

FIG. 4



FIG. 5

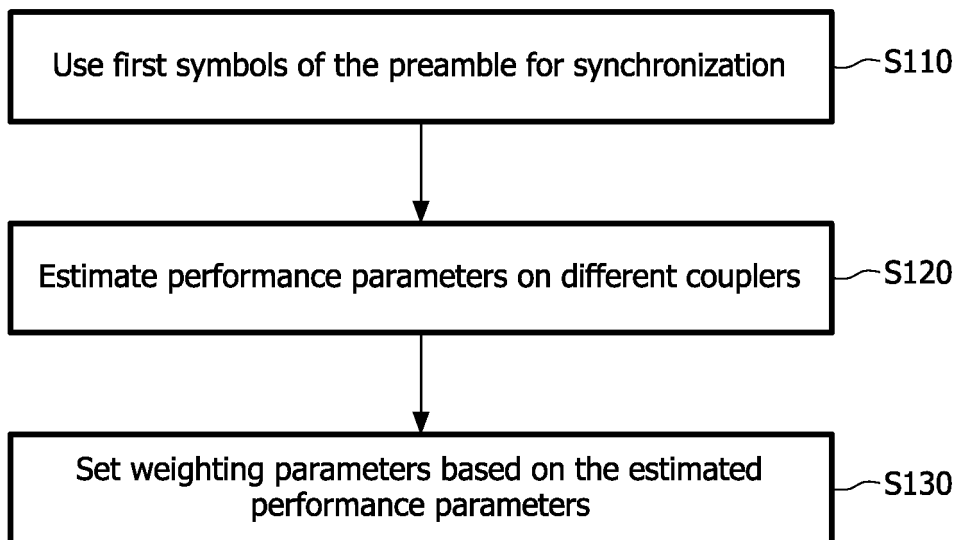

FIG. 6

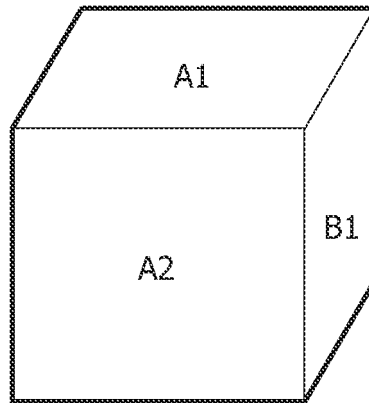

FIG. 7

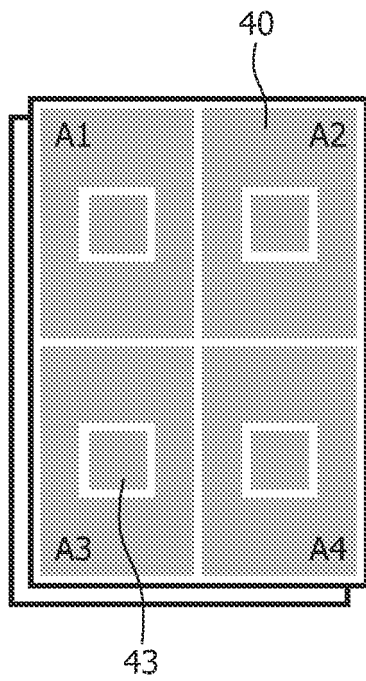

FIG. 8A

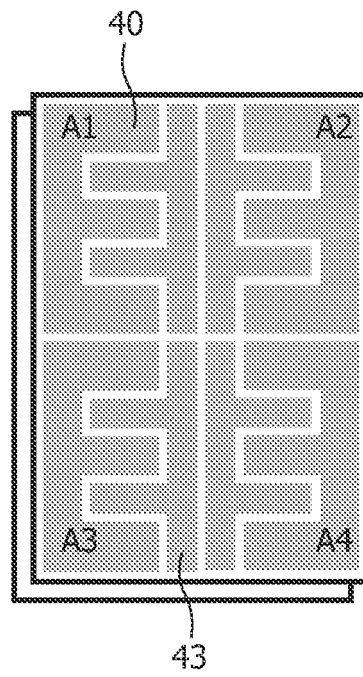

FIG. 8B

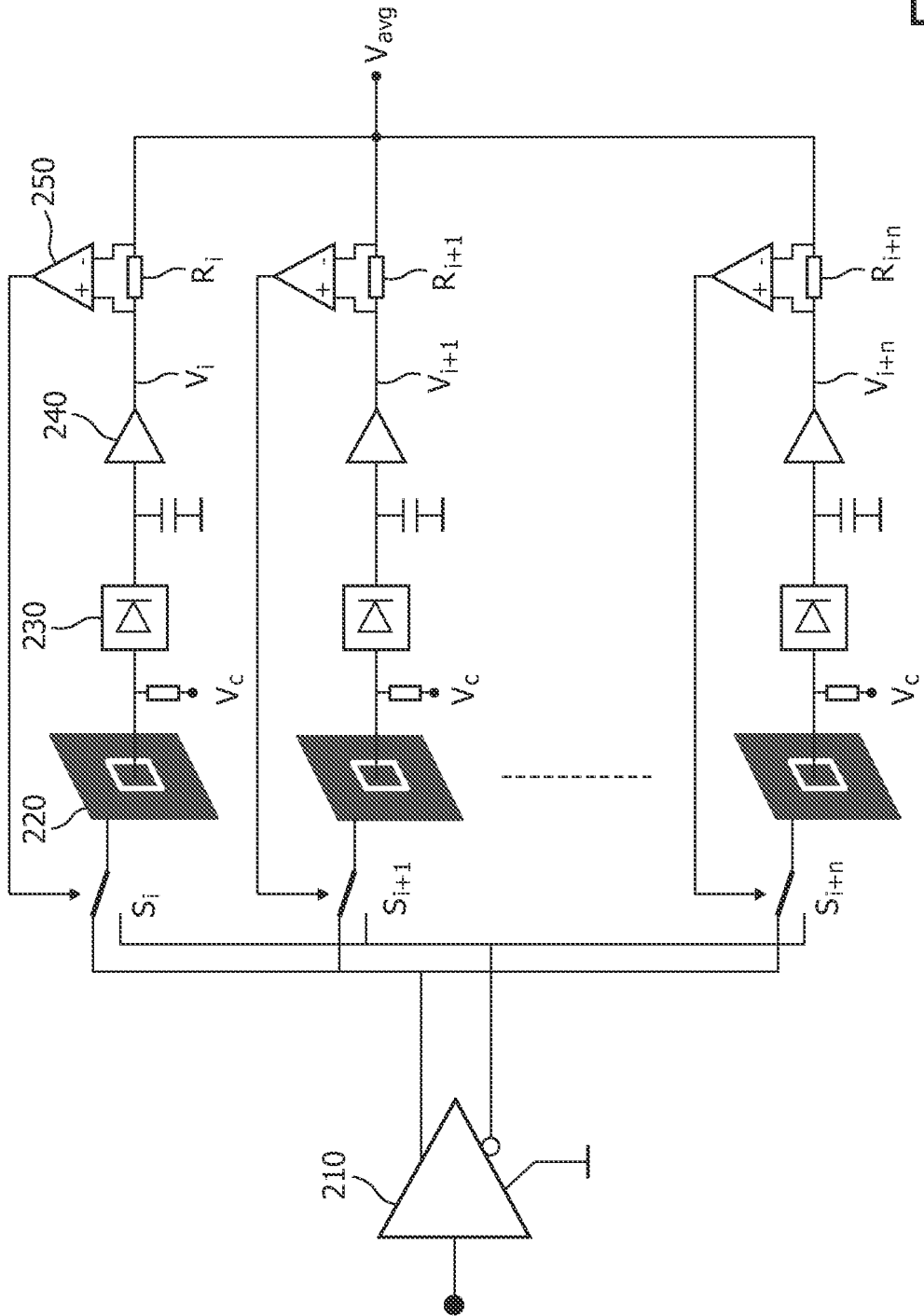

FIG. 9

REFERENCES CITED IN THE DESCRIPTION

This list of references cited by the applicant is for the reader's convenience only. It does not form part of the European patent document. Even though great care has been taken in compiling the references, errors or omissions cannot be excluded and the EPO disclaims all liability in this regard.

Patent documents cited in the description

- US 6992565 B [0004]
- US 6777992 B [0004]
- US 6223018 B [0004]
- US 5914701 A [0004]
- WO 2006132058 A1 [0012]
- WO 2007148877 A1 [0013]

Non-patent literature cited in the description

- Personal Area Networks (PAN): Near-Field Intra-Body Communication. **THOMAS GUTHRIE ZIMMERMAN**. Master of Thesis. Massachusetts Institute of Technology, September 1995 [0004]
- **K. FUJII et al.** Study on the Transmission Mechanism for Wearable Device Using the Human Body as a Transmission Channel. *IEICE Trans Commun E88-B*, 2401-2410 [0039]

专利名称(译)	身体耦合通信系统的电极分集		
公开(公告)号	EP2241033B1	公开(公告)日	2017-06-14
申请号	EP2008865831	申请日	2008-12-18
[标]申请(专利权)人(译)	皇家飞利浦电子股份有限公司		
申请(专利权)人(译)	皇家飞利浦电子N.V.		
当前申请(专利权)人(译)	皇家飞利浦N.V.		
[标]发明人	SCHENK TIM CORNEEL WILHELMUS VAN DEN HOMBERG JOHANNES FAZZI ALBERTO		
发明人	SCHENK, TIM CORNEEL WILHELMUS VAN DEN HOMBERG, JOHANNES FAZZI, ALBERTO		
IPC分类号	H04B13/00 A61B5/00		
CPC分类号	H04B13/005 A61B5/0002 A61B5/0024 A61B5/0028		
代理机构(译)	kroeze antonius , 约翰		
优先权	2007123774 2007-12-20 EP		
其他公开文献	EP2241033A1		
外部链接	Espacenet		

摘要(译)

本发明涉及耦合器装置，处理装置和处理多个体耦合通信信号的方法，这些通信信号是通过使用具有多个电极或电极段 (40,42; 40,43) 的电极装置检测的。估计身体耦合通信信号的各个传输参数，并且基于估计的传输参数将选择和加权处理中的至少一个应用于检测到的身体耦合通信信号。然后，处理的体耦合通信信号被组合以产生分集输出信号。因此，在身体耦合或基于身体的通信系统中增加了对耦合器错位和用户便利性的鲁棒性。

