

(19)



(11)

EP 2 134 244 B1

(12)

EUROPEAN PATENT SPECIFICATION

(45) Date of publication and mention of the grant of the patent:
28.12.2016 Bulletin 2016/52

(51) Int Cl.:
A61B 3/032 ^(2006.01) **A61H 5/00** ^(2006.01)
A61B 5/16 ^(2006.01) **A61B 5/00** ^(2006.01)

(21) Application number: **08745771.9**

(86) International application number:
PCT/US2008/060237

(22) Date of filing: **14.04.2008**

(87) International publication number:
WO 2008/128183 (23.10.2008 Gazette 2008/43)

(54) METHODS FOR TESTING NEAR AND FAR VISUAL ABILITIES

VERFAHREN ZUM TESTEN VON NAH-FERN-SEHFÄHIGKEITEN

PROCÉDÉS DESTINÉS À TESTER DES FACULTÉS VISUELLES DE PRÈS ET DE LOIN

(84) Designated Contracting States:
AT BE BG CH CY CZ DE DK EE ES FI FR GB GR HR HU IE IS IT LI LT LU LV MC MT NL NO PL PT RO SE SI SK TR

• **COULTER, Ryan**
Beaverton, OR 97005-6453 (US)

(30) Priority: **13.04.2007 US 923434 P**
04.06.2007 US 941915 P

(74) Representative: **Beattie, Alex Thomas Stewart et al**
Forresters
Skygarden
Erika-Mann-Strasse 11
80636 München (DE)

(43) Date of publication of application:
23.12.2009 Bulletin 2009/52

(56) References cited:
WO-A2-2006/029048 US-A- 4 294 522
US-A- 4 618 231 US-A- 5 530 492
US-A- 5 539 481 US-A- 5 825 460
US-A- 5 825 460 US-A1- 2006 244 915
US-A1- 2007 200 927 US-B1- 6 454 412

(73) Proprietor: **NIKE Innovate C.V.**
Beaverton, OR 97005-6453 (US)

(72) Inventors:
• **REICHOW, Alan, W.**
Beaverton, OR 97005-6453 (US)

Note: Within nine months of the publication of the mention of the grant of the European patent in the European Patent Bulletin, any person may give notice to the European Patent Office of opposition to that patent, in accordance with the Implementing Regulations. Notice of opposition shall not be deemed to have been filed until the opposition fee has been paid. (Art. 99(1) European Patent Convention).

EP 2 134 244 B1

Description

TECHNICAL FIELD

[0001] The present invention relates to testing visual abilities. More particularly, the present invention relates to the testing of the visual abilities of a subject in tasks involving the shifting of visual focus from near to far fields of vision and vice versa.

BACKGROUND OF THE INVENTION

[0002] Numerous systems and methods exist to test and, in some instances, train the visual abilities of individuals. One area of visual testing measures a subject's ability to focus on visual stimuli at different distances from the subject. Often, such testing requires a subject to attempt to identify a visual indicia displayed relatively near the subject and to subsequently identify a visual indicia visually distant from the subject. Often, the visual indicia visually far from the subject will be located at optical infinity, meaning that the eyes must completely relax and both look straight ahead of a subject's head to focus on the distant visual indicia. In such testing, a subject may typically alternatively read indicia displayed on a near display and indicia displayed on a far display, with a test administrator recording the accuracy of the subject's identification of indicia. Such a testing approach renders quantifiable response times difficult to obtain. Also problematically, such an approach to testing can permit a subject to read multiple indicia at any given distance, commit the indicia to short-term memory, and then quickly identify alternating indicia without having to focus again on a display at a given distance, thereby further undermining the accuracy of any measurement of the time required for a subject to shift his or her focus on an indicia displayed at a given distance.

[0003] US5539481 discloses an exercise device for prophylaxis and improving eye acuity conditions that can be used at home or at work without any medical supervision. The device includes several visual targets, a control unit and a keyboard. The device causing one target at a time in a random order to display one of a number of predetermined characters randomly chosen. A person who use the device put equally spaced targets in front of himself or herself at a distance from 0.5' to 20' and adjust the characters displayed to minimal discernable size. During every therapy session the person must denote each character on each target through the keyboard. If the person's response is correct the next character will appear. The amount of correct responses in a session and time intervals between sessions are predetermined depending on the person's age, type of his or her activities and eye acuity conditions.

[0004] US4618231 discloses a novel instrument and method for measuring the accommodative amplitude and speed of the eye of a subject is described. The instrument for making the measurements according to the present

invention comprises a pair of illuminated or luminous visual displays disposed for viewing along an optical axis, the images of the displays superimposed upon each other for viewing by a subject, one of the displays comprising a pattern having a plurality of distinct and recognizable orientations with respect to the axis along which it is viewed, an orientation generator for randomly and alternately generating one of the orientations for viewing by the subject, a switch operable by the subject for turning the displays off and indicating the observed orientation of the random pattern, and a recorder for recording the last displayed orientation and the time the displays were on or the time between presentation of one display and the correct identification of the other.

[0005] US5530492 discloses a method and system for presenting two successive images on a video display unit as a dichoptic stimulus of substantially equal intensity, wherein a first image is displayed at a predetermined intensity so as to be seen by a first eye of an observer only, an optical shutter being used to prevent the displayed image from reaching the second eye of the observer. The first image is then extinguished and the state of the optical shutter reversed so that the first eye can no longer see the video display unit whilst a second image is presented to the second eye. In order to prevent the second eye from seeing an after image of the first image, a neutral density filter or polarizer is disposed within the light path and the second image is illuminated at a correspondingly higher intensity so as to compensate for the attenuation factor of the neutral density filter or polarizer. Such a method may be employed to measure the dark vergence of the observer which has been found to be a major factor in determining fatigue of computer operators, in order that corrective action may be taken so that the angle subtended by an image on the computer screen at the eyes of the observer may be adjusted to the angle of dark vergence. Such corrective action may be provided by individually tailored prismatic spectacles.

[0006] WO2006/029048A2 discloses a kiosk type test device for accommodative facility wherein visual indicia are displayed on two laterally displaced displays at different apparent visual distances.

SIMMARY OF THE INVENTION

[0007] The present invention provides methods to test the near and far visual focusing abilities of a subject as defined in the appended claims. A first display device is positioned near to a subject, and a second display device is positioned far from a subject. An automated voice detection system may be used to detect responses from a subject indicating that the subject has perceived a displayed visual indicia. A second visual indicia at a second distance will not be displayed until a response is received from the subject or, optionally, after the display of the first indicia has timed out. In this fashion, individual indicia at different distances from the subject may be individually displayed in an alternating fashion. The display of only

an individual indicia prevents the subject from effectively memorizing multiple indicia at a given distance, thereby providing an accurate measure of the time required for a subject to shift his or her focus to an indicia at a new distance.

BRIEF DESCRIPTION OF THE DRAWING

[0008] The present invention is described in detail below with reference to the attached drawing figures, wherein:

FIG. 1 is an illustration of a system for near far testing in accordance with the present disclosure;
 FIG. 2 further illustrates a system for near far testing in accordance with the present disclosure;
 FIG. 3A further illustrates a system for near far testing in accordance with the present invention; FIG. 3B further illustrates a system for near far testing in accordance with the present disclosure;
 FIG. 3B further illustrates a system for near far testing in accordance with the present disclosure;
 FIG. 3C further illustrates a system for near far testing in accordance with the present disclosure;
 FIGS. 4A and 4B illustrate a method for near far testing in accordance with the present invention; and
 FIGS. 5A and 5B illustrate a further method for near far testing in accordance with the present invention.

DETAILED DESCRIPTION

[0009] Systems and methods in accordance with the present disclosure may be used to test and/or train the visual abilities of a subject in changing the subject's focus from near to far and far to near. Systems and methods in accordance with the disclosure may utilize at least one near display device and at least one far display device. A far display device may be located at or near optical infinity from a subject. A near display device may be located at differing distances from a subject, ranging from a few inches to several feet. Additionally, multiple display devices at multiple distances may be used, such as a near display device, a far display device, and a mid-range display device located between the near display device and the far display device. Also, multiple near display devices and/or multiple far display devices may be used. Further, display devices may be located in differing directions from a subject. For example, the angle of vision of display devices may differ, with some to the left of a subject's line of vision and some to the right of a subject's line of vision. Display devices may also be positioned higher or lower than the subject's normal line of vision. One skilled in the art will appreciate that different positioning of display devices may be suitable for testing and/or training individuals for particular activities. For example, a baseball shortstop might have to quickly shift visual focus from a batter striking a pitched ball (essentially at optical infinity) to a position towards the ground

at approximately the shortstop's knees to field a ground ball. For this reason, visual testing and/or training of an individual playing shortstop might focus on the individual's abilities to focus visually in those two positions. The various aspects of systems and methods in accordance with the present disclosure are described more fully in association with the attached figures.

[0010] Referring now to FIG. 1, a system 100 for testing and/or training the near and far visual abilities of a subject is illustrated. A first display device 120 (also referred to as the near display device) may be located visually near to subject 110. The precise distance from subject 110 to near display device 120 may vary depending upon the particular visual ability to be tested or trained, but will be less than optical infinity. A second display device 130 may be located visually far from subject 110. Second display device 130, alternatively referred to as the far display device 130 or distant display device 130, may be located at or near optical infinity relative to subject 110. A microphone 140 may receive spoken responses from subject 110 in response to visual indicia displayed on near display device 120 and/or far display device 130. A testing unit 150 may connect to near display device 120, far display device 130, and microphone 140, as well as other equipment such as a camera 170 and/or pressure sensitive platform 180, which will be described further below: Testing unit 180 may control the display of indicia and the receipt of responses from subject 110. One skilled in the art will appreciate that testing unit 150 may be a computer, such as a personal computer or a gaming device, or other specialized computing device.

[0011] One skilled in the art will appreciate and understand that subject 110 may provide any suitable type of input in response to the displayed visual indicia. For example, in another embodiment of the present disclosure, subject 110 may provide responses using a motor input device. Motor input device may be any device, such as a joystick or keypad, capable of receiving manual input from subject 110, and may also be any device capable of receiving input from any other type of physical action by subject 110, such as foot actuated pedals or buttons. Examples of appropriate devices for use as an input device include keyboards or keypads, buttons, joysticks, switches, pedals, or any other device capable of receiving an active input from subject 110.

[0012] As illustrated in FIG. 1, an indicia 160 may be displayed on near display device 120. As illustrated in FIG. 1, indicia 160 comprises a Landolt C. A Landolt C may be used because they are visually neutral indicia that may possess a trait, namely orientation to either the right, left, top, or bottom, that are easily recognized by subjects. As illustrated in FIG. 1, the Landolt C of indicia 160 is oriented to the right as viewed by subject 110.

[0013] As illustrated in FIG. 1, system 100 may further utilize a camera 170 to monitor the movements of subject 110 during testing and/or training. Camera 170 may further be devoted to tracking eye movement of subject 110 to correlate eye movement data with the responses given

by subject 110 to the display of various indicia on near display device 120 and/or far display device 130. Still referring to FIG. 1, system 100 may further utilize a pressure sensitive platform 180 upon which subject 110 stands during testing and/or training. Pressure sensitive platform 180 may detect shifts in the balance of subject 110 during testing and/or training, which may then be correlated by testing unit 150 to the responses of subject 110 to indicia displayed on near display device 120 and/or far display device 130.

[0014] Referring now to FIG. 2, system 100 is illustrated with indicia 160 removed from near display device 120. For example, subject 110 may have correctly identified the indicia 160 displayed in FIG. 1 as oriented to the right, by example by speaking the word "right" into microphone 140. Upon receiving a correct input, or alternatively upon receiving an incorrect input or receiving no input during a pre-determined amount of time, testing unit 150 may remove the display of an indicia upon near display device 120 and commence the display of an indicia 260 on far display device 130. In the example illustrated in FIG. 2, indicia 260 is a Landolt C, this time with an orientation towards the top. Of course, one of ordinary skill in the art will appreciate that the orientation of the Landolt C shown as indicia 260 may vary from that shown and described herein. One skilled in the art will further appreciate that indicia other than Landolt C's, as illustrated in FIG. 1 and FIG. 2 may be used in accordance with the present invention. For example, numerals, letters, pictures, photographs, or other types of indicia that may be recognized by a subject 110 may be utilized.

[0015] Referring now to FIG. 3A, a further view of system 100 is illustrated. In system 100 near display device 120 is positioned at a first distance 310 from subject 110. As further illustrated in FIG. 3A, near display device 120 is elevated to height approximately at eye level of subject 110. One skilled in the art will appreciate that other elevations and distances are possible, both for near display device 120 and far display device 170. Far display device 170 being located at a second distance 320 from subject 110. One skilled in the art will further appreciate that near display device 120 and far display device 130, as well as additional display devices (not illustrated) if used may be positioned at differing angles of view relative to subject 110.

[0016] Referring now to FIG. 3B, system 100 is illustrated with near display device 120 located at another exemplary distance relative to subject 110. As illustrated in FIG. 3B, near display device 120 is located at a first distance 311 from subject 110, essentially at arm's length. Meanwhile, far display device 130 is located at a second distance 321 from subject 110.

[0017] Referring now to FIG. 3C, system 100 is illustrated with a plurality of near display devices 121, 122, 123. As show in FIG. 3C, the plurality of near display devices 121, 122, 123 are oriented horizontally relative to subject 110. For example, near display devices 121, 122, 123 may be positioned on the floor or ground, or

may be located at differing heights oriented horizontally relative to subject 110. The first near display device 121 may be located at a first distance from subject 312, the second near display device 122 may be located at a second distance 313 from subject 110, and the third near display device 123 may be located at a third distance 314 from subject 110. Meanwhile, far display device 130 may be located at a fourth distance 322 from subject 110. As illustrated in FIG. 3C, a system 100 in accordance with the present disclosure may further test and/or train a subject's ability to detect a displayed indicia from a number of possible display areas, such as multiple possible display devices. A similar configuration may be utilized with the far display device 130, with multiple far display devices in differing positions or orientations being utilized relative to subject 110.

[0018] Referring now to FIG. 4A and FIG. 4B, a method 400 in accordance with the present invention is illustrated. In step 410 a first visual indicia may be displayed at a first distance at a first time. For example, step 410 may display a visual indicia on a near display device at a first time as illustrated in any of FIGS. 1 - 3C.

[0019] In step 415 a first input may be received indicating that the subject perceived the first visual indicia. Step 415 may, for example, utilize a microphone coupled to a testing unit to detect an input from a subject. The input may, for example, identify a characteristic possessed by a displayed indicia, such as the orientation of a Landolt C, the identity of a numeral or a letter, the identity of a displayed picture or photograph, the color of a displayed indicia, etc.

[0020] In step 420 the time elapsed between the first time at which the indicia was displayed and the receipt of the first input may be determined. Step 420 may be appropriately performed by a testing unit that controls the display of the first visual indicia in step 410 and that operates in conjunction with a microphone to receive the first input in step 415.

[0021] In step 425, after receiving the first input a second visual indicia may be displayed at a second distance at a second time. For example, a visual indicia may be displayed at a far display device at a second time. In step 430 a second input may be received indicating that the subject perceived the second visual indicia.

[0022] Step 430 may resemble step 415 in terms of the types of inputs that may be received and the manner in which the input may be received, although one of ordinary skill in the art will appreciate that the characteristic, if any, identified for the displayed indicia may differ based upon the characteristic possessed by different displayed indicia.

[0023] In step 435, the time elapsed between the second time at which the second visual indicia was displayed and the receipt of the second input may be determined. Step 435, as with step 420, may be appropriately performed by a testing unit.

[0024] In step 440, after receiving a second input a third visual indicia may be displayed at the first distance

and at a third time. For example, step 440 may display a third indicia on the near display device after a subject has responded in step 430 to a displayed indicia on the far display device.

[0025] In step 445 a third input may be received indicating that the subject perceived the third visual indicia. Step 445 may resemble step 415.

[0026] In step 450, the time elapsed between the third time at which the third indicia was displayed and the receipt of the third input may be determined. Step 450 may resemble step 420.

[0027] In step 455, after receiving the third input a fourth visual indicia may be displayed at a second distance and at a fourth time. For example, step 455 may display a fourth visual indicia at the far display device after receiving an input responsive to the display of the third visual indicia on the near display device. Step 455 may resemble step 425.

[0028] In step 460, an input may be received indicating that the subject perceived the fourth visual indicia. Step 460 may resemble step 430. In step 465 the time elapsed between the fourth time and the receipt of the fourth input may be determined. Step 465 may resemble step 435.

[0029] In step 470 a score may be calculated quantifying the subject's performance based upon the determined times elapsed. One skilled in the art will appreciate that further iterations of displays of indicia and receipts of appropriate inputs, along with a determination of elapsed times, may be performed prior to the performance of step 470. Step 470 may indicate, for example, that a subject responds slowly to indicia displayed at a first distance but does not respond slowly to the display of indicia at a second distance, which would be indicative of a subject with focusing or vergence difficulties at the first distance but not at the second distance.

[0030] Referring now to FIGS. 5A and 5B, a further method 500 in accordance with the present invention is illustrated. In step 510 a first display device visually near to a subject may be provided. In step 520 a second display device visually far from the subject may be provided. Step 520 may provide a display device at or near optical infinity from a subject.

[0031] In testing/training step 540, which may comprise a number of sub-steps, a visual indicia may be displayed on the display devices and inputs may be received until testing/training has concluded. In sub-step 541 a visual indicia possessing an identifying characteristic may be displayed on the first display device at a first time. Sub-step 542 determines whether an input has been received from a subject. Step 542 may be performed, for example, by a testing unit in conjunction with a microphone. If the result of sub-step 542 is that no input has been received a timeout determination may be made in sub-step 543. The timeout determination of sub-step 543 may be made, for example, by a testing unit. If no timeout has been reached in sub-step 543, method 500 may continue to wait for an input in sub-step 542. If a timeout determination is made in sub-step 543, method 500 may

proceed to sub-step 546, which will be described subsequently. If in sub-step 542 an input is received, method 500 may proceed to sub-step 544. Sub-step 544 determines whether the input correctly identifies the characteristic of the displayed indicia. For example, the displayed indicia may have a given orientation, identity, color, or other trait that may be identified in the input. Method 500 may then proceed to sub-step 545 to determine the time elapsed from the first time to receipt of the input in sub-step 542. Method 500 may then proceed to sub-step 546, which may also be reached as a result of a timeout decision in sub-step 543. In sub-step 546 whether an input correctly identified a characteristic, the elapsed time prior to receiving the input, and/or whether a timeout occurred may be recorded. Sub-step 546 may be performed, for example, by a testing unit and may utilize an electronic recording media such as a hard drive, memory, removable storage such as a compact disk, a DVD, a floppy disk, printing to a physical media such as paper, or other type of recording device. Method 500 may thereafter proceed to sub-step 547 of displaying a visual indicia possessing an identifying characteristic on the visually far display device at a second time. Method 500 may then proceed to sub-step 548, which determines whether an input has been received. Sub-step 548, like sub-step 542, may be performed by a testing unit in conjunction with a microphone. If the conclusion of sub-step 548 is that no input has been received, method 500 may proceed to sub-step 549 of determining whether a timeout has occurred. If no timeout has occurred, method 500 may return to sub-step 548 of determining whether an input has been received. Sub-step 549 may, for example, be performed by a testing unit, as was sub-step 543. If the result of sub-step 548 was to determine that an input was received, method 500 may proceed to sub-step 550. Sub-step 550 determines whether an input correctly identified the characteristic of the displayed indicia. Method 500 may then proceed to sub-step 551, which determines the time elapsed from the second time to the receipt of the input. Method 500 may then proceed to sub-step 552, which may also be reached if the conclusion of sub-step 549 is that a timeout has occurred. Sub-step 552 may record whether an input correctly identified the characteristic, record the elapsed time and/or record that a timeout occurred. As with sub-step 546, sub-step 552 may be performed by testing unit using any kind of recording media. Method 500 may then proceed to sub-step 553 to determine whether a test or training session has concluded. If the outcome of sub-step 553 is that the test/training is not over, method 500 may return to sub-step 541 and then the testing/training may continue. If the result of sub-step 553 is the conclusion that the test/training has concluded, testing step 540 may conclude and method 500 may proceed to step 560, which calculates a score based on responses correctly identifying characteristics, the elapsed times, and timeouts. A score may particularly identify the performance of a subject at a given distance. One skilled in the art will further

appreciate that method 500 may utilize additional display devices at additional distances and directions from subject. In such an embodiment, additional sub-steps would be included in testing step 540 for the display devices at additional distances.

[0032] These and other variations to the systems and methods of the present disclosure will be apparent to those of ordinary skill in the art.

Claims

1. A method for testing the vision of a subject (110), the method comprising:

providing a near display device (120) at a first distance (310, 311) located visually near to the test subject (110) and a far display device (130) at a second distance (320, 321) located visually far from the test subject (110);
 displaying a first visual indicia (160) on the near display device (120) at a first time;
 receiving a first input indicating that the test subject (110) perceived the first visual indicia (160);
 displaying a second visual indicia (260) on the far display device (130) at a second time only after receiving the first input indicating that the test subject (110) perceived the first visual indicia (160), the second distance (320,312) differing significantly from the first distance (310,311);
 and
 receiving a second input indicating that the test subject perceived the second visual indicia (260),

wherein the near and far display devices (120,130) are positioned at differing angles of view relative to the subject, with one (120,130) to the left of the subject's normal line of vision and the other (130,120) to the right of the subject's normal line of vision, and the method further comprises:

determining the time elapsed between the first time and the receipt of the first input; and
 determining the time elapsed between the second time and the receipt of the second input.

2. The method for testing the vision of a subject of claim 1, the method further comprising:

displaying a third visual indicia at the first distance from the test subject (110) at a third time only after receiving the second input indicating that the test subject (110) perceived the second visual indicia; and
 receiving a third input indicating that the test subject (110) perceived the third visual indicia.

3. The method for testing the vision of a subject of claim 2, the method further comprising:

displaying a fourth visual indicia at the second distance from the test subject (110) at a fourth time only after receiving the third input indicating that the test subject (110) perceived the third visual indicia;
 and receiving a fourth input indicating that the test subject (110) perceived the fourth visual indicia.

4. The method for testing the vision of a subject of claim 3, the method further comprising:

determining the time elapsed between the third time and the receipt of the third input; and
 determining the time elapsed between the fourth time and the receipt of the fourth input.

5. A method according to claim 1, the method comprising:

receiving the first input as a spoken input from the subject (110) responding to the first visual indicia (160) using an automated voice detection system;
 determining whether the first input indicates that the subject (110) correctly perceived the first visual indicia (160) displayed on the near display device (120);
 after receiving the first input indicating that the subject (110) correctly perceived the first visual indicia (160), displaying the second visual indicia (260) on the far display device (130);
 receiving the second input as a spoken input from the subject (110) responding to the second visual indicia (260) using an automated voice detection system;
 determining from the second input whether the subject (110) correctly perceived the second visual indicia (260) displayed on the far display device (130); and
 after receiving the second spoken input indicating that the subject (110) correctly perceived the second visual indicia (260), determining whether the test has concluded and if the test has not concluded returning to the step of displaying the first visual indicia (160) on the near display device (120).

6. The method for testing the vision of a subject of claim 5, wherein the steps of determining the time elapsed comprise:

determining the time elapsed from the first time to the receipt of the spoken input indicating that the subject (110) correctly perceived the first vis-

- ual indicia (160) displayed on the near display device (120); and
determining the time elapsed from the second time to the receipt of the spoken input indicating that the subject (110) correctly perceived the second visual indicia (260) displayed on the far display device (130). 5
7. The method for testing the vision of a subject of claim 4 or 6, further comprising calculating a score quantifying the performance of the subject (110) using the determined times elapsed. 10
8. The method for testing the vision of a subject of claim 5, wherein: 15
- each of the first and second visual indicia possesses an identifying characteristic;
determining whether the first input indicates that the subject (110) correctly perceived the first visual indicia (160) comprises determining whether the first input indicates that the subject (110) correctly perceived the identifying characteristic possessed by the first visual indicia (160);
determining whether the second input indicates that the subject (110) correctly perceived the second visual indicia (260) comprises determining whether the subject (110) correctly perceived the identifying characteristic possessed by the second visual indicia (260). 20 25
9. The method for testing the vision of a subject of claim 8, wherein the identifying characteristic possessed by the displayed visual indicia (160,260) comprises at least one of a directional orientation and a color. 30 35
10. The method for testing the vision of a subject of claim 8, wherein the identifying characteristic possessed by the displayed indicia (160,260) is an alphanumeric identity.
11. The method for testing the vision of a subject according to claim 8, the method comprising:
- if no first input is received within a predetermined amount of time after the first time, determining that the display of the first visual indicia (160) has timed out;
recording whether the first input correctly or incorrectly identified the characteristic possessed by the first visual indicia (160) and whether the display has timed out;
after either receiving the first input from the subject (110) or determining that the display of the first visual indicia (160) has timed out, displaying the second visual indicia (260) on the far display device (130) at the second time;
if no second input is received within a predeter- 45 50 55
- mined amount of time after the second time, determining that the display of the second visual indicia (260) has timed out;
recording whether the second input correctly or incorrectly identified the characteristic possessed by the second visual indicia (260) and whether the display has timed out; and
after either receiving the second input from the subject (110) or determining that the display of the second visual indicia (260) has timed out, determining whether the test has concluded and if the test has not concluded returning to the step of displaying the first visual indicia (160) on the near display device (120); and
calculating a score quantifying the performance of the subject (110) based upon the number of inputs correctly identifying the characteristics possessed by the displayed indicia (160, 260).
12. The method for testing the vision of a subject of claim 11, further comprising the steps of:
- recording the elapsed time between the first time and the receipt of the first input; and
recording the elapsed time between the second time and the receipt of the second input.
13. The method for testing the vision of a subject of claim 12, wherein calculating a score quantifying the performance of the subject (110) based upon the number of inputs correctly identifying the characteristics possessed by the displayed indicia (160,260) is based upon the number of inputs correctly identifying the characteristics possessed by the displayed indicia (160,260) and the recorded elapsed times.

Patentansprüche

- 40 1. Verfahren zum Testen der Sehkraft eines Subjekts (110), wobei das Verfahren Folgendes umfasst:
- Bereitstellen einer Nahanzeigevorrichtung (120) in einem ersten Abstand (310, 311) in visueller Nähe zum Testsubjekt (110) und einer Fernanzeigevorrichtung (130) in einem zweiten Abstand (320, 321) in visueller Ferne vom Testsubjekt (110);
Anzeigen eines ersten visuellen Zeichens (160) auf der Nahanzeigevorrichtung (120) zu einem ersten Zeitpunkt;
Entgegennehmen einer ersten Eingabe, die angibt, dass das Testsubjekt (110) das erste visuelle Zeichen (160) wahrnahm;
Anzeigen eines zweiten visuellen Zeichens (260) auf der Fernanzeigevorrichtung (130) zu einem zweiten Zeitpunkt erst nach Entgegennehmen der ersten Eingabe, die angibt, dass

- das Testsubjekt (110) das erste visuelle Zeichen (160) wahrnahm, wobei sich der zweite Abstand (320, 312) erheblich vom ersten Abstand (310, 311) unterscheidet; und
Entgegennehmen einer zweiten Eingabe, die angibt, dass das Testsubjekt das zweite visuelle Zeichen (260) wahrnahm,
- worin die Nah- und Fernanzeigevorrichtungen (120, 130) unter verschiedenen Blickwinkeln auf das Subjekt bezogen positioniert sind, mit einer (120, 130) zur Linken der normalen Sichtlinie des Subjekts und der anderen (130, 120) zur Rechten der normalen Sichtlinie des Subjekts, und das Verfahren ferner Folgendes umfasst:
- Bestimmen der zwischen dem ersten Zeitpunkt und der Entgegennahme der ersten Eingabe verstrichenen Zeit; und
Bestimmen der zwischen dem zweiten Zeitpunkt und der Entgegennahme der zweiten Eingabe verstrichenen Zeit.
- 2.** Verfahren zum Testen der Sehkraft eines Subjekts nach Anspruch 1, wobei das Verfahren ferner Folgendes umfasst:
- Anzeigen eines dritten visuellen Zeichens im ersten Abstand vom Testsubjekt (110) zu einem dritten Zeitpunkt erst nach Entgegennehmen der zweiten Eingabe, die angibt, dass das Testsubjekt (110) das zweite visuelle Zeichen wahrnahm; und
Entgegennehmen einer dritten Eingabe, die angibt, dass das Testsubjekt (110) das dritte visuelle Zeichen wahrnahm.
- 3.** Verfahren zum Testen der Sehkraft eines Subjekts nach Anspruch 2, wobei das Verfahren ferner Folgendes umfasst:
- Anzeigen eines vierten visuellen Zeichens im zweiten Abstand vom Testsubjekt (110) zu einem vierten Zeitpunkt erst nach Entgegennehmen der dritten Eingabe, die angibt, dass das Testsubjekt (110) das dritte visuelle Zeichen wahrnahm;
und Entgegennehmen einer vierten Eingabe, die angibt, dass das Testsubjekt (110) das vierte visuelle Zeichen wahrnahm.
- 4.** Verfahren zum Testen der Sehkraft eines Subjekts nach Anspruch 3, wobei das Verfahren ferner Folgendes umfasst:
- Bestimmen der zwischen dem dritten Zeitpunkt und der Entgegennahme der dritten Eingabe verstrichenen Zeit; und
- Bestimmen der zwischen dem vierten Zeitpunkt und der Entgegennahme der vierten Eingabe verstrichenen Zeit.
- 5.** Verfahren nach Anspruch 1, wobei das Verfahren Folgendes umfasst:
- Entgegennehmen der ersten Eingabe als gesprochene Eingabe vom Subjekt (110), das auf das erste visuelle Zeichen (160) anspricht, mithilfe eines automatisierten Spracherkennungssystems;
Bestimmen dessen, ob die erste Eingabe angibt, dass das Subjekt (110) das auf der Nahanzeigevorrichtung (120) angezeigte erste visuelle Zeichen (160) korrekt wahrnahm;
nach Entgegennehmen der ersten Eingabe, die angibt, dass das Subjekt (110) das erste visuelle Zeichen (160) korrekt wahrnahm, Anzeigen des zweiten visuellen Zeichens (260) auf der Fernanzeigevorrichtung (130);
Entgegennehmen der zweiten Eingabe als gesprochene Eingabe vom Subjekt (110), das auf das zweite visuelle Zeichen (260) anspricht, mithilfe eines automatisierten Spracherkennungssystems;
Bestimmen anhand der zweiten Eingabe, ob das Subjekt (110) das auf der Fernanzeigevorrichtung (130) angezeigte zweite visuelle Zeichen (260) korrekt wahrnahm; und
nach Entgegennehmen der zweiten gesprochenen Eingabe, die angibt, dass das Subjekt (110) das zweite visuelle Zeichen (260) korrekt wahrnahm, Bestimmen dessen, ob der Test abgeschlossen ist, und, wenn der Test nicht abgeschlossen ist, Rückkehr zum Schritt des Anzeigens des ersten visuellen Zeichens (160) auf der Nahanzeigevorrichtung (120).
- 6.** Verfahren zum Testen der Sehkraft eines Subjekts nach Anspruch 5, worin die Schritte des Bestimmens der verstrichenen Zeit Folgendes umfassen:
- Bestimmen der verstrichenen Zeit vom ersten Zeitpunkt bis zur Entgegennahme der gesprochenen Eingabe, die angibt, dass das Subjekt (110) das auf der Nahanzeigevorrichtung (120) angezeigte erste visuelle Zeichen (160) korrekt wahrnahm; und
Bestimmen der verstrichenen Zeit vom zweiten Zeitpunkt bis zur Entgegennahme der gesprochenen Eingabe, die angibt, dass das Subjekt (110) das auf der Fernanzeigevorrichtung (130) angezeigte zweite visuelle Zeichen (160) korrekt wahrnahm.
- 7.** Verfahren zum Testen der Sehkraft eines Subjekts nach Anspruch 4 oder 6, ferner umfassend das Be-

rechnen einer Bewertung, die die Leistung des Subjekts (110) mithilfe der bestimmten verstrichenen Zeiten quantifiziert.

8. Verfahren zum Testen der Sehkraft eines Subjekts nach Anspruch 5, worin:

jedes der ersten und zweiten visuellen Zeichen ein kennzeichnendes Merkmal besitzt;
 das Bestimmen dessen, ob die erste Eingabe angibt, dass das Subjekt (110) das erste visuelle Zeichen (160) korrekt wahrnahm, das Bestimmen dessen umfasst, ob die erste Eingabe angibt, dass das Subjekt (110) das vom ersten visuellen Zeichen (160) besessene kennzeichnende Merkmal korrekt wahrnahm;
 das Bestimmen dessen, ob die zweite Eingabe angibt, dass das Subjekt (110) das zweite visuelle Zeichen (260) korrekt wahrnahm, das Bestimmen dessen umfasst, ob das Subjekt (110) das vom zweiten visuellen Zeichen (260) besessene kennzeichnende Merkmal korrekt wahrnahm.

9. Verfahren zum Testen der Sehkraft eines Subjekts nach Anspruch 8, worin das vom angezeigten visuellen Zeichen (160, 260) besessene kennzeichnende Merkmal mindestens eine einer Richtungsorientierung und einer Farbe umfasst.

10. Verfahren zum Testen der Sehkraft eines Subjekts nach Anspruch 8, worin das vom angezeigten Zeichen (160, 260) besessene kennzeichnende Merkmal eine alphanumerische Identität ist.

11. Verfahren zum Testen der Sehkraft eines Subjekts nach Anspruch 8, wobei das Verfahren Folgendes umfasst:

wenn keine erste Eingabe innerhalb eines vorbestimmten Zeitraums nach dem ersten Zeitpunkt entgegengenommen wird, Bestimmen dessen, dass die Anzeige des ersten visuellen Zeichens (160) abgelaufen ist;
 Aufzeichnen dessen, ob die erste Eingabe das vom ersten visuellen Zeichen (160) besessene Merkmal korrekt oder inkorrekt identifizierte und ob die Anzeige abgelaufen ist;
 entweder nach Entgegennehmen der ersten Eingabe vom Subjekt (110) oder Bestimmen dessen, dass die Anzeige des ersten visuellen Zeichens (160) abgelaufen ist, Anzeigen des zweiten visuellen Zeichens (260) auf der Fernanzeigevorrichtung (130) zum zweiten Zeitpunkt;
 wenn keine zweite Eingabe innerhalb eines vorbestimmten Zeitraums nach dem zweiten Zeitpunkt entgegengenommen wird, Bestimmen

dessen, dass die Anzeige des zweiten visuellen Zeichens (260) abgelaufen ist;

Aufzeichnen dessen, ob die zweite Eingabe das vom zweiten visuellen Zeichen (260) besessene Merkmal korrekt oder inkorrekt identifizierte und ob die Anzeige abgelaufen ist; und

entweder nach Entgegennehmen der zweiten Eingabe vom Subjekt (110) oder Bestimmen dessen, dass die Anzeige des zweiten visuellen Zeichens (260) abgelaufen ist, Bestimmen dessen, ob der Test abgeschlossen ist, und, wenn der Test nicht abgeschlossen ist, Rückkehr zum Schritt des Anzeigens des ersten visuellen Zeichens (160) auf der Nahanzeigevorrichtung (120); und

Berechnen einer Bewertung, die die Leistung des Subjekts (110) auf Basis der Anzahl Eingaben quantifiziert, die die vom angezeigten Zeichen (160, 260) besessenen Merkmale korrekt identifizieren.

12. Verfahren zum Testen der Sehkraft eines Subjekts nach Anspruch 11, ferner umfassend die folgenden Schritte:

Aufzeichnen der zwischen dem ersten Zeitpunkt und der Entgegennahme der ersten Eingabe verstrichenen Zeit; und

Aufzeichnen der zwischen dem zweiten Zeitpunkt und der Entgegennahme der zweiten Eingabe verstrichenen Zeit.

13. Verfahren zum Testen der Sehkraft eines Subjekts nach Anspruch 12, worin das Berechnen einer Bewertung, die die Leistung des Subjekts (110) auf Basis der Anzahl Eingaben quantifiziert, die die vom angezeigten Zeichen (160, 260) besessenen Merkmale korrekt identifizieren, auf der Anzahl Eingaben, die die vom angezeigten Zeichen (160, 260) besessenen Merkmale korrekt identifizieren, und den aufgezeichneten verstrichenen Zeiten basiert.

Revendications

1. Procédé de test de la vision d'un sujet (110), le procédé consistant à :

fournir un dispositif d'affichage proche (120) à une première distance (310, 311) située visuellement proche du sujet de test (110), et un dispositif d'affichage éloigné (130) à une seconde distance (320, 321) située visuellement loin du sujet de test (110) ;

afficher un premier indice visuel (160) sur le dispositif d'affichage proche (120) à un premier temps ;

recevoir une première entrée indiquant que le

sujet de test (110) a perçu le premier indice visuel (160) ;
 afficher un deuxième indice visuel (260) sur le dispositif d'affichage éloigné (130) à un deuxième temps uniquement après la réception de la première entrée indiquant que le sujet de test (110) a perçu le premier indice visuel (160), la seconde distance (320, 312) différant significativement de la première distance (310, 311) ; et recevoir une deuxième entrée indiquant que le sujet de test a perçu le deuxième indice visuel (260),

les dispositifs d'affichage proche et éloigné (120, 130) étant positionnés à différents angles de vue par rapport au sujet, l'un (120, 130) étant situé à gauche de la ligne normale de vision du sujet, et l'autre (130, 120) étant situé à droite de la ligne normale de vision du sujet, et le procédé consistant en outre à :

déterminer le temps écoulé entre le premier temps et la réception de la première entrée ; et déterminer le temps écoulé entre le deuxième temps et la réception de la deuxième entrée.

2. Procédé de test de la vision d'un sujet selon la revendication 1, le procédé consistant en outre à :

afficher un troisième indice visuel à la première distance par rapport au sujet de test (110) à un troisième temps uniquement après la réception de la deuxième entrée indiquant que le sujet de test (110) a perçu le deuxième indice visuel ; et recevoir une troisième entrée indiquant que le sujet de test (110) a perçu le troisième indice visuel.

3. Procédé de test de la vision d'un sujet selon la revendication 2, le procédé consistant en outre à :

afficher un quatrième indice visuel à la seconde distance par rapport au sujet de test (110) à un quatrième temps uniquement après la réception de la troisième entrée indiquant que le sujet de test (110) a perçu le troisième indice visuel ; et recevoir une quatrième entrée indiquant que le sujet de test (110) a perçu le quatrième indice visuel.

4. Procédé de test de la vision d'un sujet selon la revendication 3, le procédé consistant en outre à :

déterminer le temps écoulé entre le troisième temps et la réception de la troisième entrée ; et déterminer le temps écoulé entre le quatrième temps et la réception de la quatrième entrée.

5. Procédé selon la revendication 1, le procédé con-

sistant à :

recevoir la première entrée sous forme d'entrée parlée par le sujet (110) répondant au premier indice visuel (160) au moyen d'un système automatique de détection de voix ;

déterminer si la première entrée indique que le sujet (110) a perçu correctement le premier indice visuel (160) affiché sur le dispositif d'affichage proche (120) ;

après la réception de la première entrée indiquant que le sujet (110) a perçu correctement le premier indice visuel (160), afficher le deuxième indice visuel (260) sur le dispositif d'affichage éloigné (130) ;

recevoir la deuxième entrée sous forme d'entrée parlée par le sujet (110) répondant au deuxième indice visuel (260) au moyen d'un système automatique de détection de voix ;

déterminer à partir de la deuxième entrée si le sujet (110) a perçu correctement le deuxième indice visuel (260) affiché sur le dispositif d'affichage éloigné (130) ; et

après la réception de la deuxième entrée parlée indiquant que le sujet (110) a perçu correctement le deuxième indice visuel (260), déterminer si le test est terminé, et si le test n'est pas terminé, retourner à l'étape consistant à afficher le premier indice visuel (160) sur le dispositif d'affichage proche (120).

6. Procédé de test de la vision d'un sujet selon la revendication 5, dans lequel les étapes consistant à déterminer le temps écoulé consistent à :

déterminer le temps écoulé entre le premier temps et la réception de l'entrée parlée indiquant que le sujet (110) a perçu correctement le premier indice visuel (160) affiché sur le dispositif d'affichage proche (120) ; et

déterminer le temps écoulé entre le deuxième temps et la réception de l'entrée parlée indiquant que le sujet (110) a perçu correctement le deuxième indice visuel (260) affiché sur le dispositif d'affichage éloigné (130).

7. Procédé de test de la vision d'un sujet selon la revendication 4 ou 6, consistant en outre à calculer un score quantifiant la performance du sujet (110) au moyen des temps écoulés déterminés.

8. Procédé de test de la vision d'un sujet selon la revendication 5, dans lequel :

chacun des premier et deuxième indices visuels possède une caractéristique d'identification ; l'étape consistant à déterminer si la première entrée indique que le sujet (110) a perçu correc-

- tement le premier indice visuel (160) consiste à déterminer si la première entrée que le sujet (110) a perçue correctement la caractéristique d'identification que possède le premier indice visuel (160) ;
l'étape consistant à déterminer si la deuxième entrée indique que le sujet (110) a perçue correctement le deuxième indice visuel (260) consiste à déterminer si le sujet (110) a perçue correctement la caractéristique d'identification que possède le deuxième indice visuel (260).
9. Procédé de test de la vision d'un sujet selon la revendication 8, dans lequel la caractéristique d'identification que possèdent les indices visuels (160, 260) affichés comprend une orientation directionnelle et/ou une couleur.
10. Procédé de test de la vision d'un sujet selon la revendication 8, dans lequel la caractéristique d'identification que possèdent les indices (160, 260) affichés est une identité alphanumérique.
11. Procédé de test de la vision d'un sujet selon la revendication 8, le procédé consistant à :
- si aucune première entrée n'est reçue dans un délai prédéterminé après le premier temps, détermine que l'affichage du premier indice visuel (160) a expiré ;
enregistrer si la première entrée a identifié correctement ou incorrectement la caractéristique que possède le premier indice visuel (160) et si l'affichage a expiré ;
après la réception de la première entrée du sujet (110) ou de la détermination que le premier indice visuel (160) a expiré, afficher le deuxième indice visuel (260) sur le dispositif d'affichage éloigné (130) au deuxième temps ;
si aucune deuxième entrée n'est reçue dans un délai prédéterminé après le deuxième temps, détermine que l'affichage du deuxième indice visuel (260) a expiré ;
enregistrer si la deuxième entrée a identifié correctement ou incorrectement la caractéristique que possède le deuxième indice visuel (260) et si l'affichage a expiré ; et
après la réception de la deuxième entrée du sujet (110) ou de la détermination que l'affichage du deuxième indice visuel (260) a expiré, déterminer si le test est terminé, et si le test n'est pas terminé, retourner à l'étape consistant à afficher le premier indice visuel (160) sur le dispositif d'affichage proche (120) ; et
calculer un score quantifiant la performance du sujet (110) sur la base du nombre d'entrées identifiant correctement les caractéristiques que possèdent les indices (160, 260) affichés.
12. Procédé de test de la vision d'un sujet selon la revendication 11, comprenant en outre les étapes consistant à :
- enregistrer le temps écoulé entre le premier temps et la réception de la première entrée ; et enregistrer le temps écoulé entre le deuxième temps et la réception de la deuxième entrée.
13. Procédé de test de la vision d'un sujet selon la revendication 12, dans lequel le calcul d'un score quantifiant la performance du sujet (110) sur la base du nombre d'entrée identifiant correctement les caractéristiques que possèdent les indices (160, 260) affichés repose sur le nombre d'entrées identifiant correctement les caractéristiques que possèdent les indices (160, 260) affichés et sur les temps écoulés enregistrés.

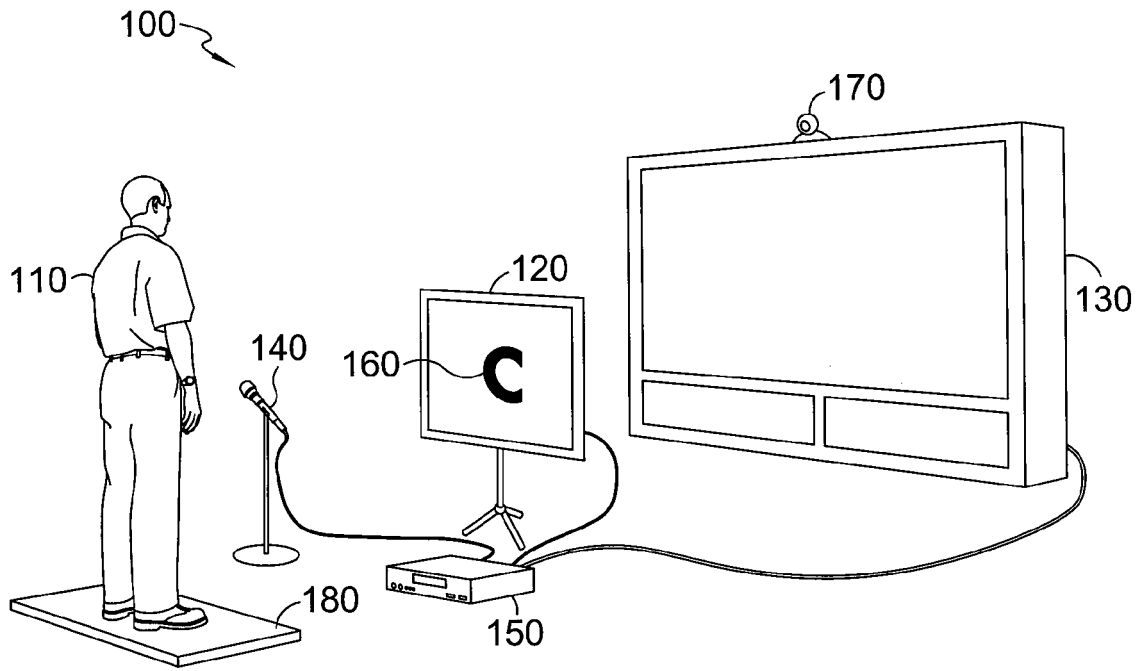

FIG. 1.

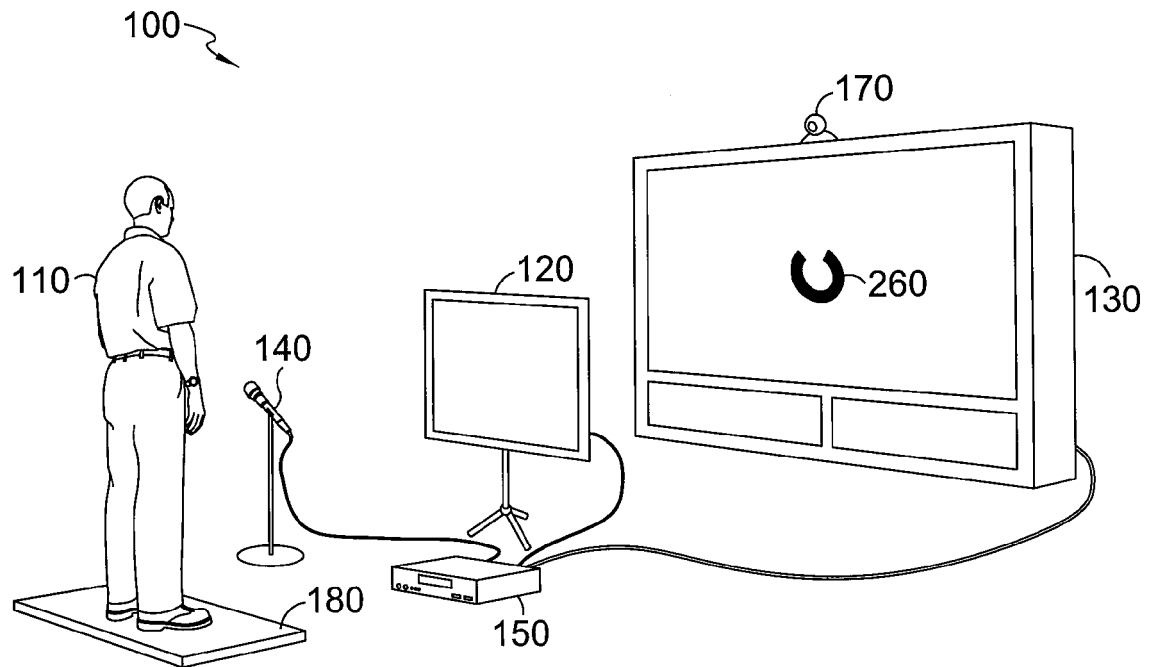

FIG. 2.

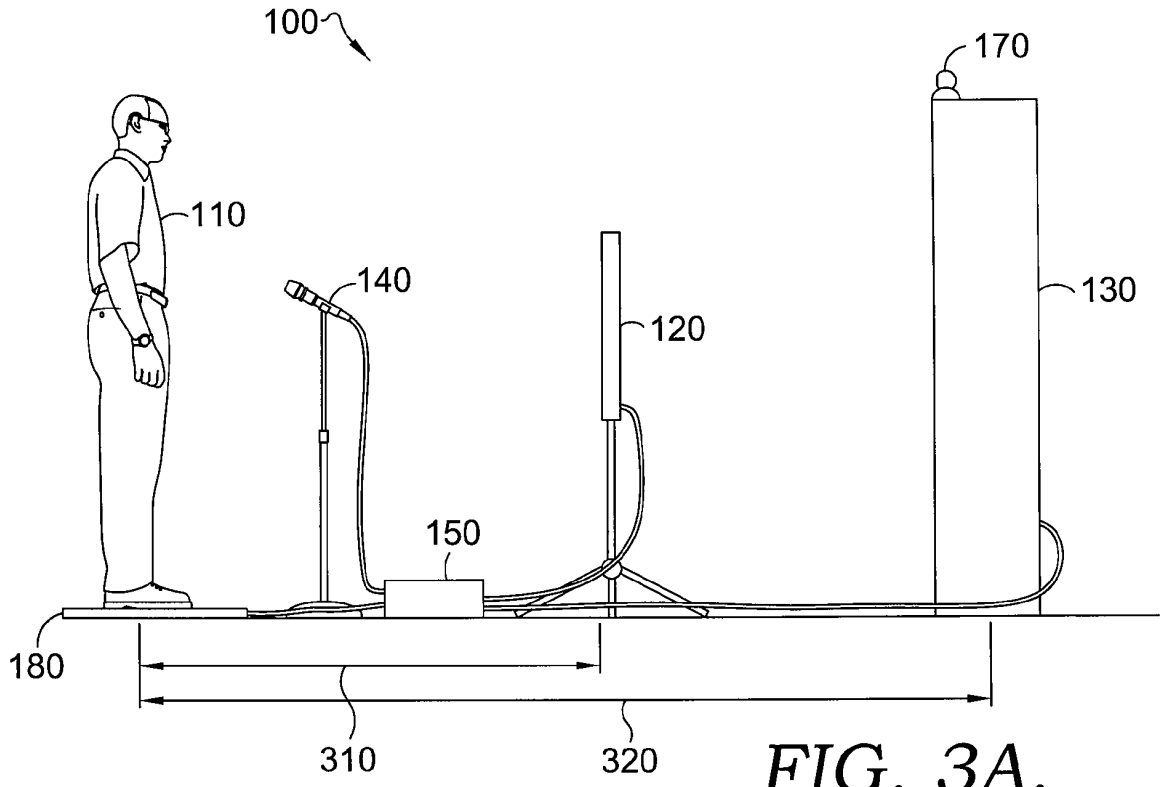

FIG. 3A.

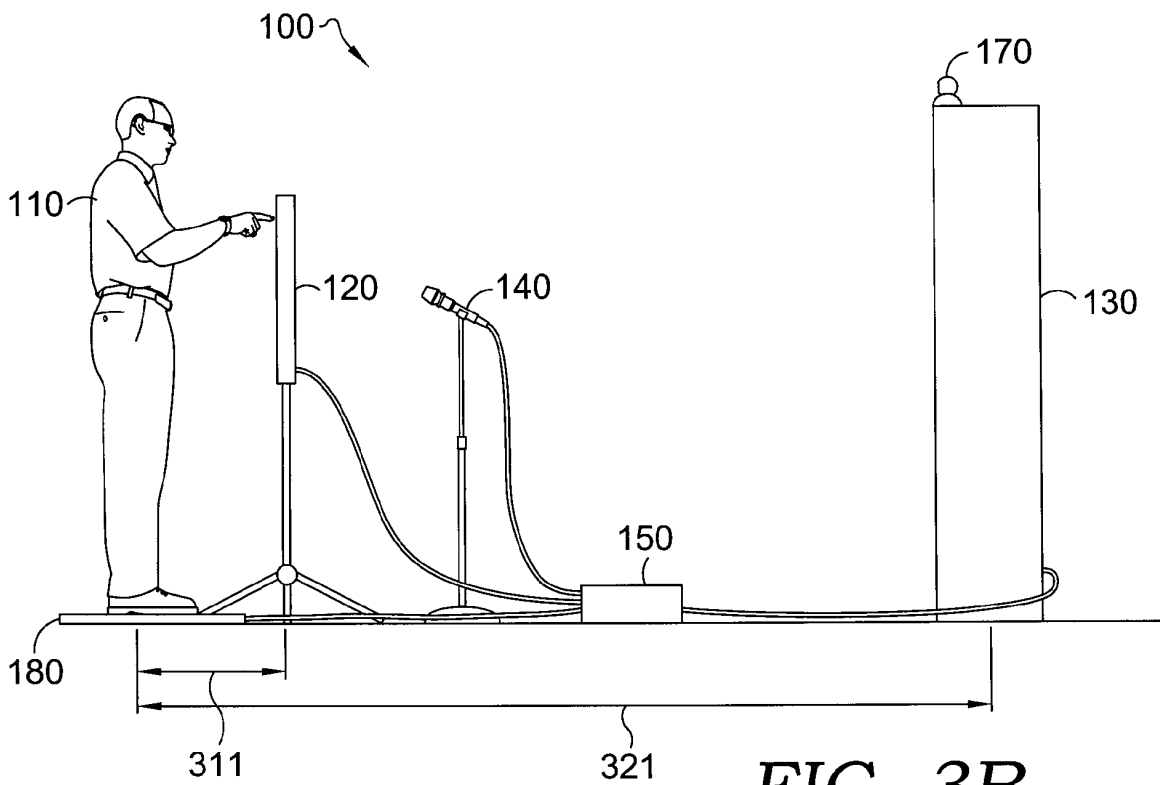

FIG. 3B.

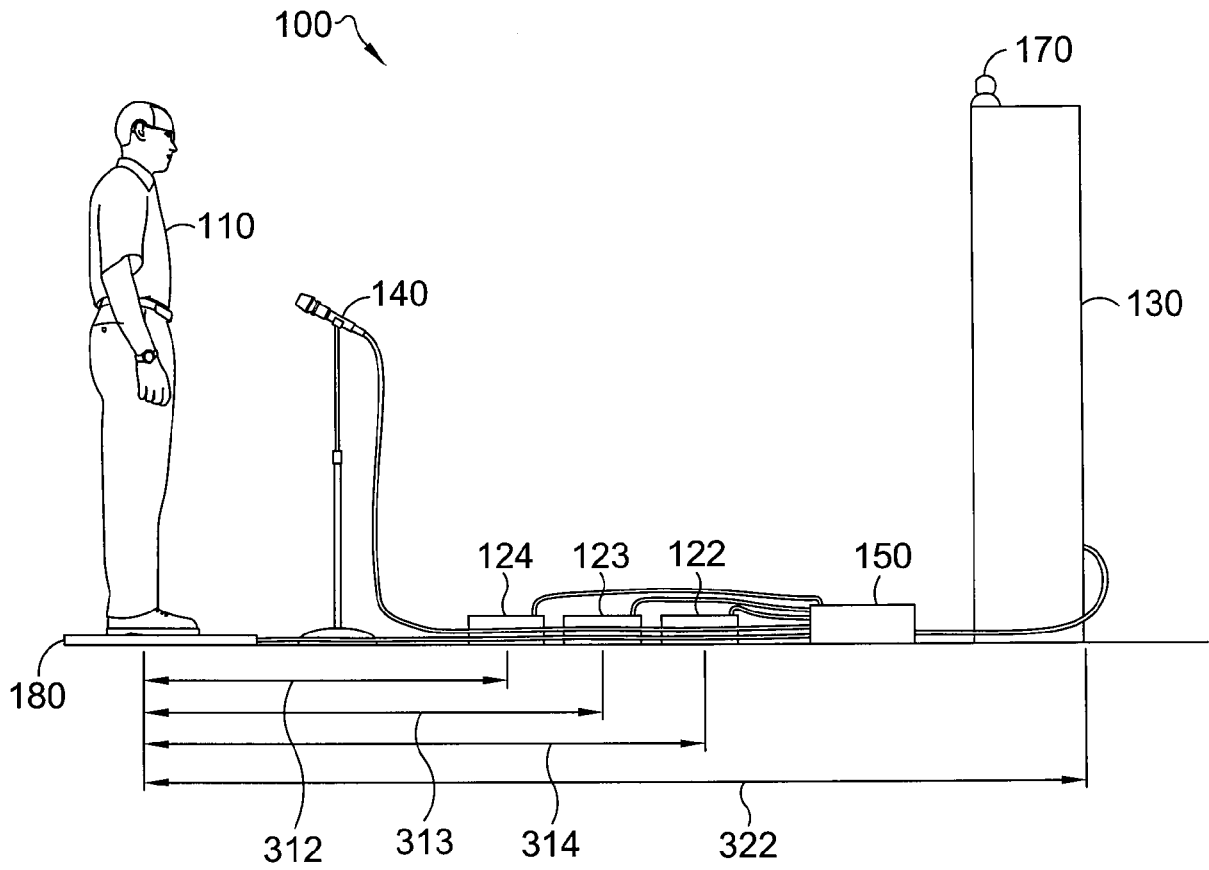

FIG. 3C.

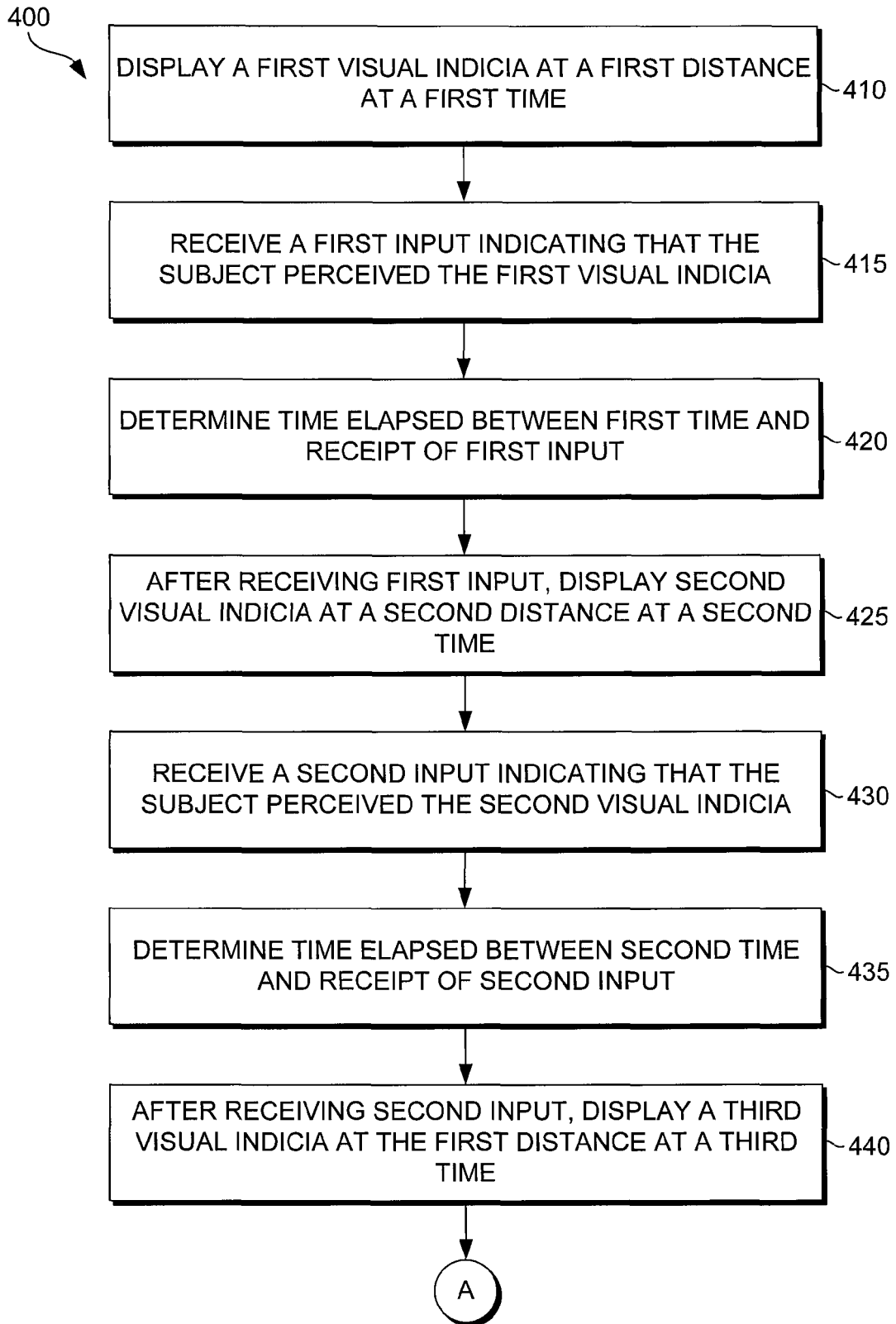

FIG. 4A.

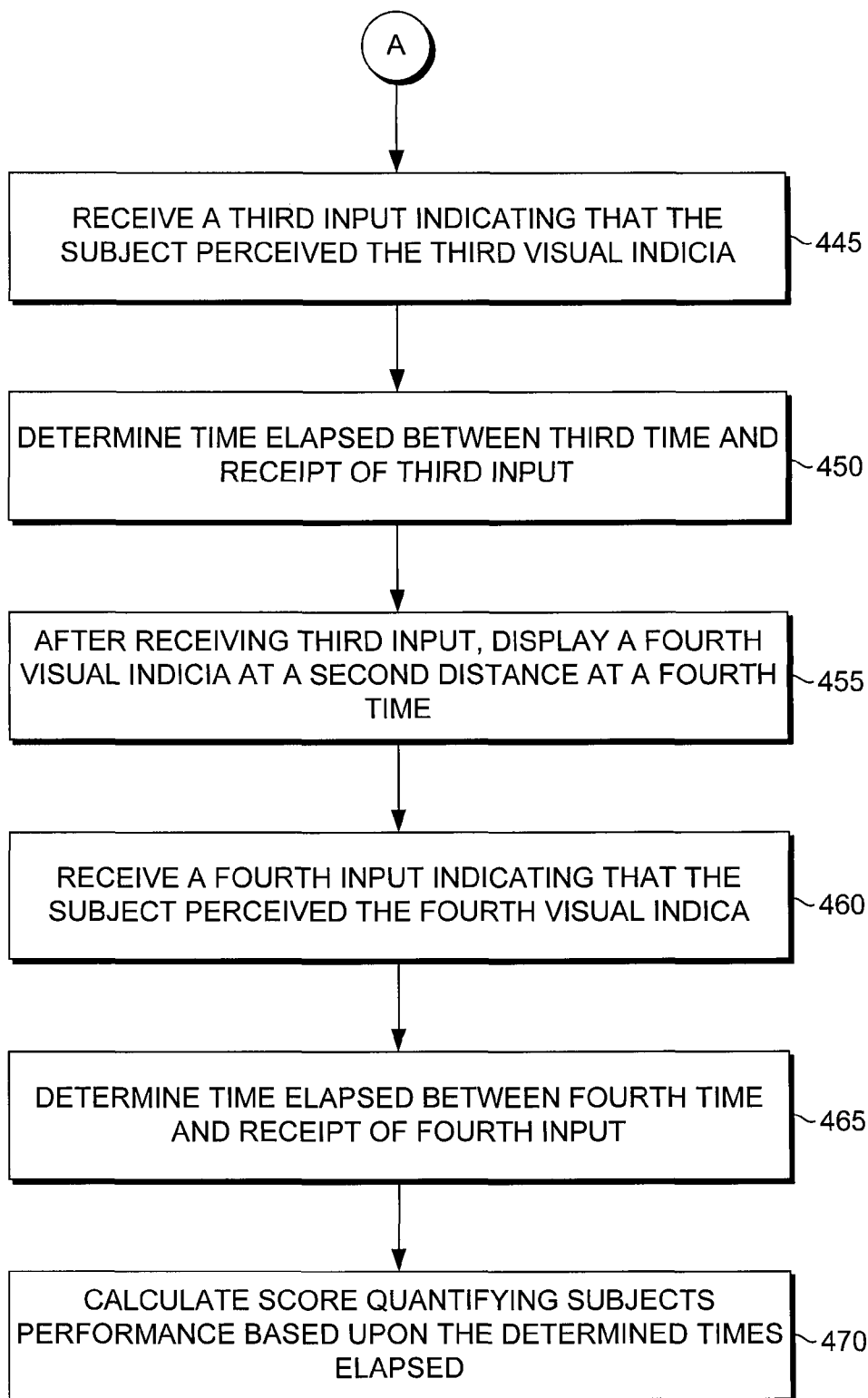
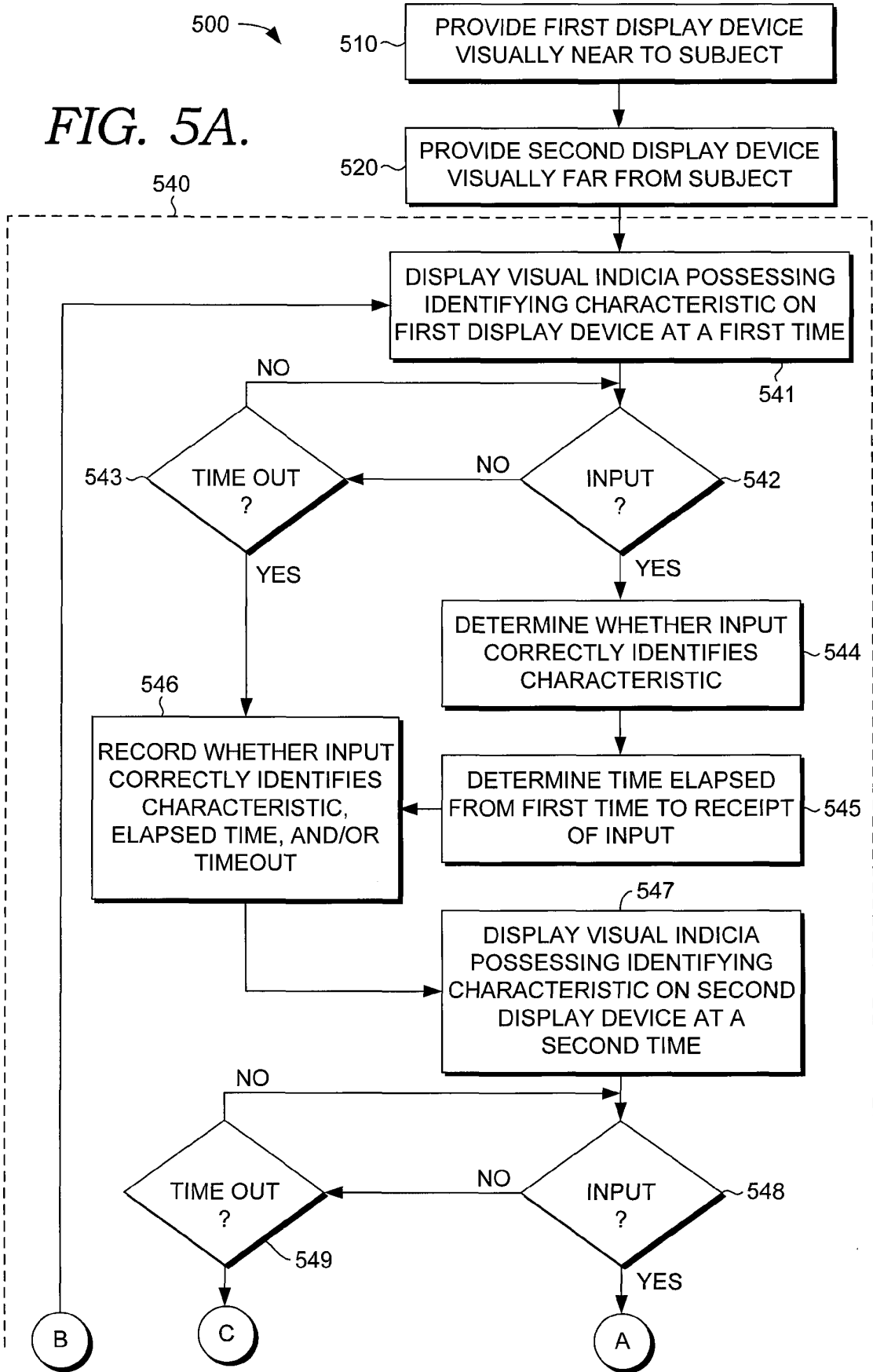

FIG. 4B.

FIG. 5A.



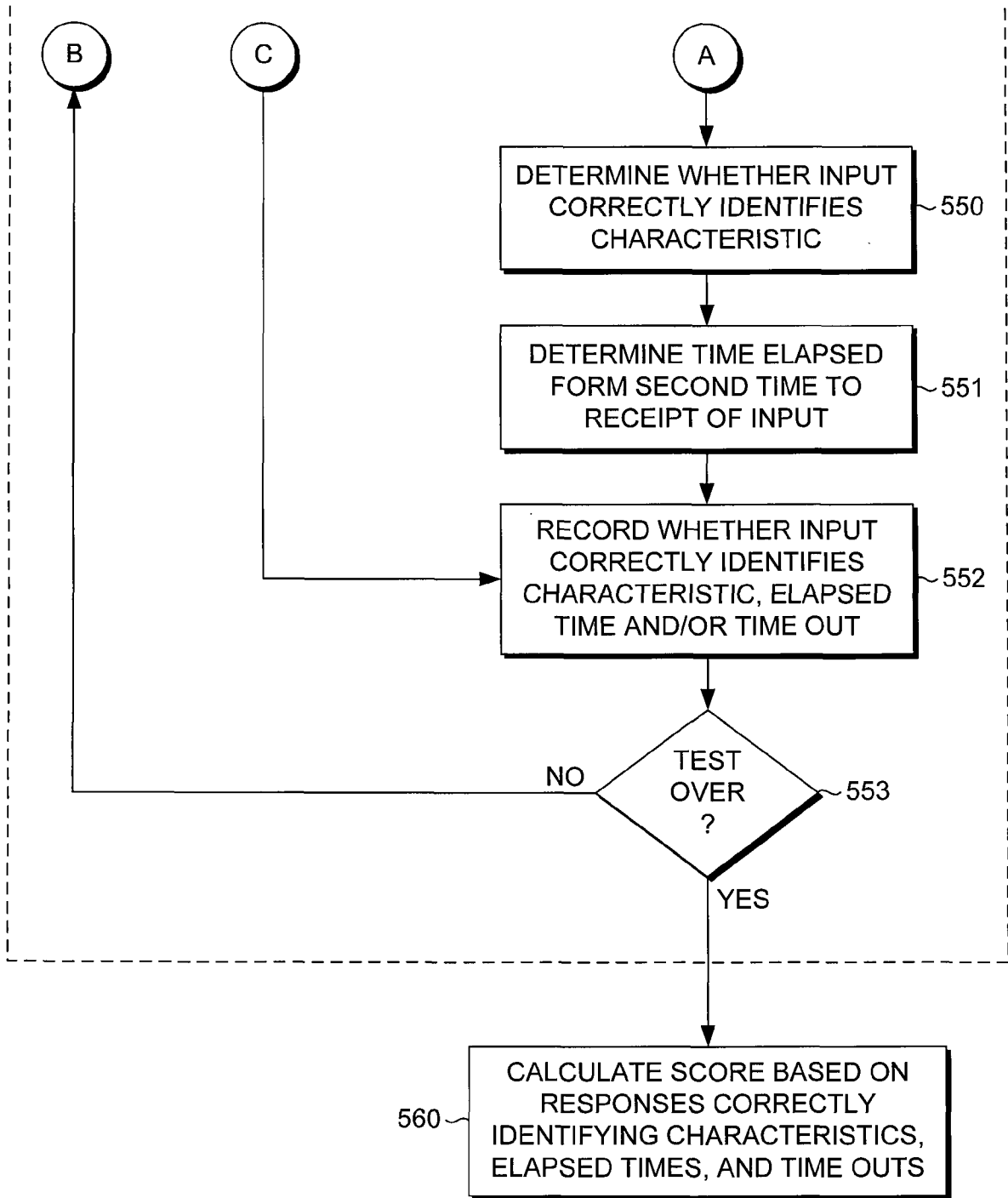

FIG. 5B.

REFERENCES CITED IN THE DESCRIPTION

This list of references cited by the applicant is for the reader's convenience only. It does not form part of the European patent document. Even though great care has been taken in compiling the references, errors or omissions cannot be excluded and the EPO disclaims all liability in this regard.

Patent documents cited in the description

- US 5539481 A [0003]
- US 4618231 A [0004]
- US 5530492 A [0005]
- WO 2006029048 A2 [0006]

专利名称(译)	用于测试和/或训练近视和远视觉能力的系统和方法		
公开(公告)号	EP2134244A4	公开(公告)日	2010-09-01
申请号	EP2008745771	申请日	2008-04-14
[标]申请(专利权)人(译)	耐克国际有限公司		
申请(专利权)人(译)	NIKE INTERNATIONAL LTD.		
当前申请(专利权)人(译)	NIKE INTERNATIONAL LTD.		
[标]发明人	REICHOW ALAN W COULTER RYAN		
发明人	REICHOW, ALAN, W. COULTER, RYAN		
IPC分类号	A61B3/00 A61B3/032 A61B5/00 A61B5/16 A61H5/00		
CPC分类号	A61B3/032 A61B5/1036 A61B5/162 A61B5/7475 A61B5/749 A61H5/00 A61H2201/5048 A61H2201/5071		
优先权	60/923434 2007-04-13 US 60/941915 2007-06-04 US		
其他公开文献	EP2134244A1 EP2134244B1		
外部链接	Espacenet		

摘要(译)

提供了用于在不同距离处自动测试和/或训练受试者的视觉能力的系统和方法。近显示设备可以显示具有特征的视觉标记。在接收到识别由所显示的标记所拥有的视觉特性的输入之后，可以在远显示设备上显示第二标记。在接收到识别在远显示设备上显示的标记的特性的输入之后，进一步的测试可以在近显示设备和远显示设备之间交替进行。可以使用两个以上的显示设备，其中显示设备相对于对象位于不同的距离或位置。