



(11) **EP 1 865 833 B1**

(12) **EUROPEAN PATENT SPECIFICATION**

(45) Date of publication and mention of the grant of the patent:
10.08.2011 Bulletin 2011/32

(21) Application number: **06748910.4**

(22) Date of filing: **29.03.2006**

(51) Int Cl.:
A61B 5/00 (2006.01)

(86) International application number:
PCT/US2006/011600

(87) International publication number:
WO 2006/105269 (05.10.2006 Gazette 2006/40)

(54) **LOCATION DETECTION SYSTEM FOR A PATIENT HANDLING DEVICE**

STANDORTDETEKTIONSSYSTEM FÜR EINE PATIENTENTRANSPORTVORRICHTUNG

SYSTEME DE DETECTION D'EMPLACEMENT POUR UN DISPOSITIF DE MANIPULATION DE PATIENT

(84) Designated Contracting States:
AT BE BG CH CY CZ DE DK EE ES FI FR GB GR HU IE IS IT LI LT LU LV MC NL PL PT RO SE SI SK TR

(30) Priority: **29.03.2005 US 665955 P**
07.11.2005 US 734083 P

(43) Date of publication of application:
19.12.2007 Bulletin 2007/51

(73) Proprietor: **Stryker Canadian Management Inc.**
Québec QC G0R 2C0 (CA)

(72) Inventors:
• **BECKER, David, Terrance**
Grand Rapids, Michigan 49548 (US)
• **MACDONALD, Bruce, L.**
Portage, Michigan 49024 (US)
• **MROZ, Joseph, E.**
Hastings, Michigan 49058 (US)
• **HAYES, Michael, Joseph**
Kalamazoo, Michigan 49009 (US)

- **HOPPER, Christopher, John**
Kalamazoo, Michigan 49009 (US)
- **MAYORAS, Richard, C., Jr.**
Kalamazoo, Michigan 49009 (US)
- **STRYKER, Martin, W.**
Kalamazoo, Michigan 49004 (US)
- **SHANKAR, Vivek**
Kalamazoo, Michigan 49001 (US)
- **DIONNE, Jean-paul**
Levis, Québec G6V 7A6 (CA)

(74) Representative: **Coyle, Philip Aidan et al**
FRKelly
27 Clyde Road
Ballsbridge
Dublin 4 (IE)

(56) References cited:
WO-A-97/18639 WO-A-03/105095
WO-A-2004/093023 US-A- 4 958 645
US-A1- 2004 106 854 US-A1- 2004 111 024

EP 1 865 833 B1

Note: Within nine months of the publication of the mention of the grant of the European patent in the European Patent Bulletin, any person may give notice to the European Patent Office of opposition to that patent, in accordance with the Implementing Regulations. Notice of opposition shall not be deemed to have been filed until the opposition fee has been paid. (Art. 99(1) European Patent Convention).

Description

FIELD OF THE INVENTION

[0001] The present invention generally relates to location detection systems for use in facilities such as health-care facilities for tracking equipment such as patient handling devices. More specifically, the present invention relates to the location detection system having locators programmed with unique location identifiers to determine a location of the patient handling devices.

BACKGROUND OF THE INVENTION

[0002] Location detection systems are well known in the art for tracking the location of personnel and equipment in a facility. These systems have been specifically adapted for use in facilities such as healthcare facilities for tracking healthcare professionals, e.g., nurses and physicians, and for tracking equipment e.g., beds, patient monitoring devices, and the like. A typical location detection system is also referred to as an asset tracking system that utilizes tags that periodically transmit a unique identification signal. Receivers are located throughout the facility at known locations for receiving these identification signals. The receivers are wired to a central computer that processes the unique identification signals to determine a location of the asset associated with the tag.

[0003] One disadvantage of such systems is that a typical asset tracking system does not utilize existing infrastructure within the healthcare facility. As a result, the capital costs necessary to provide the infrastructure to accommodate asset tracking is high. For instance, the receivers used to receive the identification signals from the tags attached to the assets being tracked must be installed throughout the healthcare facility, as well as wired to the central computer. This requires considerable labor and expense, as well as lengthy disruptions to install the wiring.

[0004] In today's healthcare facilities, networks are provided for accessing patient data, equipment data, lab results, and the like. However, with current asset tracking systems, integrating information regarding the location of mobile equipment such as patient handling devices with patient data or other data available on the network is not practical. One reason that most asset tracking systems cannot be integrated wholly with current healthcare facility networks is that these asset tracking systems are only designed to identify a particular room in which a patient handling device is located. These systems are not designed to determine a specific zone in the room in which the patient handling device is located. In some healthcare facilities each room may accommodate two, three, or more patient handling devices. Therefore, when current asset tracking systems are used, the room location of each of tube patient handling devices can be determined, e.g., the patient handling devices are in room

1, but they are not sensitive enough to determine that patient handling device no. 1 is in zone 1 of room 1, patient handling device no. 2 is in zone 2 of room 1, etc. In order for current asset tracking systems to provide this level of location detail, separate receivers are needed in each zone, with each receiver being wired to the central computer. As a result, the infrastructure costs further escalate.

[0005] Therefore, there is a need in the art for a location detection system that can easily be implemented in existing healthcare facilities with little capital investment and additional infrastructure while also providing specific location details that enable the location information to be fully integrated with other data such as patient data and other equipment data available on existing networks in the healthcare facility.

US-A-2004/0106854 disclose a transceiver worn by patients for receiving location signals from randomly placed locators. The transceiver transmits the location signals provided by the locators along with patient ID signals to a remote processing station to determine the location of the patients.

SUMMARY OF THE INVENTION AND ADVANTAGES

[0006] The present invention provides a location detection system as claimed in claim 1 and a method as claimed in claim 19.

[0007] This system and method have several advantages over the prior art. For instance, by placing the receiver on the patient handling device, the patient handling device acts as the communication link between the locator and the processing station. Furthermore, by transmitting the unique location identifier from the locators to the receiver and then on to the processing station, there is no need for additional infrastructure in the facility to support the locators. Locations can be determined simply by placing the locator, programmed with the unique location identifier, in the location of interest, and transmitting that location to the patient handling device, which then sends the unique location identifier onto the processing station. The patient handling device also transmits its own unique ID thereby correlating the location of the patient handling device to its unique ID. This will enable healthcare facilities to better track patients by associating patients with their patient handling devices and further associating the patient handling devices with their location in the healthcare facility, down to the specific zone in the room in which the patients and the patient handling devices are located.

[0008] In another aspect, the location detection system comprises a first locating device associated with the patient handling device for transmitting a first unique location identifier to the processing station and a second locating device associated with the patient handling device for transmitting a second unique location identifier to the processing station. In this system, the first unique location identifier corresponds to a first area of the loca-

tion and the second unique location identifier corresponds to a second area of the location different than the first area. In one embodiment, the first unique location identifier identifies the room in which the patient handling device is located and the second unique location identifier identifies the zone in the room in which the patient handling device is positioned. Therefore, the first locating device provides a general vicinity of the patients handling device, while the second location device further defines the location of the patient handling device in the general vicinity.

[0009] In another aspect, existing asset tracking systems can be utilized to determine general vicinity information for the patient handling devices such as the room in which they are located, and the patient handling devices can be further outfitted with the second locating device to refine the location information down to the specific zone in the room in which the patient handling device is located.

[0010] In yet another aspect, a method of detecting the location of the patient handling devices using the first and second locating devices is provided. The method includes transporting the patient handling device to the location in the facility and transmitting a first unique location identifier to the processing station. The method also includes determining the first area location of the patient handling device from the first unique location identifier and transmitting a second unique location identifier to the processing station wherein the first unique location identifier corresponds to the first area of the location and the second unique location identifier corresponds to the second area of the location.

BRIEF DESCRIPTION OF THE DRAWINGS

[0011] Other advantages of the present invention will be readily appreciated, as the same becomes better understood by reference to the following detailed description when considered in connection with the accompanying drawings wherein:

[0012] Figure 1 is a schematic view of a healthcare facility with a network;

[0013] Figure 2 is a top view of a typical room floor plan in the healthcare facility with two zones labeled A and B, schematically illustrating a location detection system of the present invention utilizing a locator configured for transmitting a unique location identifier to a receiver located on a patient handling device;

[0014] Figure 3 is an electrical schematic of the locator of Figure 2;

[0015] Figure 4 is an electrical schematic of the receiver of Figure 2;

[0016] Figure 5 is a process flow diagram illustrating a process for transmitting the unique location identifier from the locator to the receiver;

[0017] Figure 6 is a process flow diagram illustrating a process for requesting the unique location identifier from the locator;

[0018] Figure 7 is a perspective view illustrating alternative location detection systems of the present invention utilizing radio frequency, magnetic inductance, ultrasonic, or modulated light systems;

[0019] Figure 8 is a perspective view illustrating an alternative location detection system of the present invention utilizing an array of RFID tags;

[0020] Figure 9 is a perspective view illustrating an alternative location detection system of the present invention utilizing an RFID swipe card;

[0021] Figure 10 is a perspective view illustrating an alternative location detection system of the present invention utilizing a tethered RFID magnet tag;

[0022] Figure 11 is a perspective view illustrating an alternative location detection system of the present invention utilizing a nurse call cable with an integrated RFID tag;

[0023] Figure 12 is a perspective view illustrating an alternative location detection system of the present invention utilizing WiFi access points;

[0024] Figure 13 is a perspective view illustrating an alternative location detection system of the present invention utilizing a power cord with an integrated ID transmitter;

[0025] Figure 14 is a perspective view illustrating an alternative location detection system of the present invention utilizing an Ethernet port to transmit the unique location identifier;

[0026] Figure 15 is a schematic view illustrating an alternative location detection system of the present invention utilizing a mesh network to determine the location of the patient handling device;

[0027] Figure 16 is a schematic view illustrating an alternative location detection system of the present invention utilizing an asset tag in combination with a switch;

[0028] Figure 17 is a schematic view illustrating an alternative location detection system of the present invention utilizing an asset tag in combination with a sonic distance finder;

[0029] Figure 18 is a schematic view illustrating an alternative location detection system of the present invention utilizing an asset tag in combination with a laser distance finder; and

[0030] Figure 19 is a schematic view illustrating an alternative location detection system of the present invention utilizing an asset tag in combination with a hall effect sensing system.

DETAILED DESCRIPTION OF THE INVENTION

[0031] Referring to the Figures, wherein like numerals indicate like or corresponding parts throughout the several views, a location detection system for a facility is generally shown at **20**. The location detection system **20** is described as being integrated into a patient handling device **22** of a healthcare facility such as a hospital. Patient handling devices **22** include devices such as beds, stretchers, cots, wheelchairs, and the like. It should be

appreciated that the present invention could also be applied to other devices located in a healthcare facility including, but not limited to infusion pumps, patient monitoring devices, patient therapy devices such as stand-alone therapy mattresses, and the like. It should also be appreciated that it could be applied to non-healthcare facilities. For purposes of description, reference is generally made to healthcare facilities.

[0032] Referring to FIG. 1, the healthcare facility includes several systems that can be placed in electronic communication with one another through a common network **32**. These systems include admission-discharge-transfer (ADT) systems **24** and patient throughput systems **26** such as those offered by Premise Development Corporation. These systems may also include eICU systems **28** such as those provided by Cerner Corporation for the remote monitoring of critically ill patients. A nurse call system **30** may also be in communication with the network **32**. For instance, a nurse call system provided by Rauland-Borg Corporation can be used to instantly transfer nurse calls from a patient to the network **32**, or to the patient's primary and/or secondary caregivers via a wireless phone **33** using well-known messaging interfaces **35**. This places the patient in immediate contact with a healthcare professional to provide faster, more efficient service.

[0033] Several communication devices may also be used to access the data or information provided by these systems **24**, **26**, **28**, **30** to receive messages or alerts from these systems **24**, **26**, **28**, **30**, or to transmit information to these systems **24**, **26**, **28**, **30**. For instance, a wireless badge **46** may be in communication with these systems **24**, **26**, **28**, **30** via wireless access points **36** provided throughout the healthcare facility. Healthcare professionals, e.g., nurses, nurse's aides, medical assistants, nurse practitioners, physician assistants, physicians, etc., may carry the wireless badges **46** to alert the nurse when a patient has called for assistance, or that an alarm condition is present. The nurse could also use the wireless badge **46** to speak to a voice recognition system to report an alarm condition, or to report that the nurse has completed a task, to report any event that may occur in the healthcare facility. Personal digital assistants (PDAs) **38** could also be in communication with the networked systems **24**, **26**, **28**, **30** to transfer data and information between the PDAs **38** and the network **32**. Similarly, laptop computers **40** could be used to transfer data and information.

[0034] Asset tracking systems **42** may also be integrated into the network **32**. Such systems **42** may include those offered by Radianse, Inc., Versus Technology, Inc. or others to track assets throughout the healthcare facility. In some embodiments, the location detection system **20** is intended to operate independently of the asset tracking system **42** to specifically identify the location, e.g., room and zone, of the patient handling devices **22**. In other embodiments, the location detection system **20** of the present invention is intended to work in conjunction

with the asset tracking system **42** to identify the location of the patient handling devices **22** in the healthcare facility.

[0035] Still referring to FIG. 1, in one embodiment of the present invention, the patient handling device **22** is adapted for communicating with the network **32**. More specifically, a central processing unit **44** (CPU) of the patient handling device **22** is in electronic communication with the network **32** via a communication module **48**. The CPU **44** carries out the functions of the patient handling device **22** such as motor functions for raising or lowering movable sections of the patient handling device **22** in response to user input, sensing functions for sensing siderail positions, bed height, patient position or bed exit, patient weight, brake positions, and the like, as will be appreciated by those skilled in the art, or therapy functions for a therapy mattress, such as rotation, percussion, or vibration functions. The CPU **44** includes the necessary processors and memory for carrying out these functions as will be appreciated by those skilled in the art.

[0036] The CPU **44** and communication module **48** are physically supported by the patient handling device **22** to move with the patient handling device **22** from location to location. Preferably, one or more housings enclose the CPU **44** and the communication module **48** with the housing or housings being mounted to a frame of the patient handling device **22**. As a result, all of the hardware necessary for connecting the CPU **44** of the patient handling device **22** to the communication module **48** is located on and supported by the patient handling device **22**. It should be appreciated that the CPU **44** and the communication module **48** could be integrated into a single chassis or could be separate connectable components linked together in a wired or wireless configuration. By providing the communication module **48** on the patient handling device **22**, the patient handling device **22** acts as a communication center or link for transmitting data and/or information related to the patient handling device **22**, including its location, to the network **32**.

[0037] The communication module **48** may be connected to the network **32** via a wired and/or wireless connection to transfer data and/or information back and forth between the CPU **44** and the hospital network **32**. In a wired configuration, the communication module **48** may be a transceiver wired through a communication link **49** to the hospital network **32**. The communication link may be an RS-232 cable, and Ethernet-compliant cable, or any other wired connection known to those skilled in the art. In a wireless configuration, the communication module **48** may be a wireless transceiver or router that is configured with a compatible wireless transceiver or router **51** located on the hospital network **32**. In some embodiments, both wired and wireless configurations are present on the patient handling device **22** to easily accommodate user preferences. It should be appreciated that in some patient handling devices **22**, there is no CPU **44**, but instead a plurality of electronic modules that communicate on a peer-to-peer network. In this instance, the

communication module **48** is simply one of the modules or nodes in the peer-to-peer network. However, for purposes of description, reference is made to a master/slave system utilizing the CPU **44** of the patient handling device **22**.

[0038] A processing station **50** is in communication with the network **32** to process data and/or information received from the various systems **24, 26, 28, 30, 42** or the patient handling device **22** via the communication module **48** to configure or control the various systems **24, 26, 28, 30, 42** or the patient handling device **22**. In one embodiment, the processing station **50** is positioned at a central nurse's station in the healthcare facility and is implemented in a workstation, e.g., a personal computer, for use at the central nurse station. The workstation may include software configured to manipulate data and/or information received from the various systems **24, 26, 28, 30, 42** or the patient handling device **22**. For instance, the workstation may be configured to receive data and/or information from the communication module **48** of the patient handling device **22** or to transfer data and/or information back to the patient handling device **22**. Such data may originate from a bed exit detection system, a bed height detection system, a weight scale, a siderail sensing system that detects a position of the siderails, a therapy mattress, and the like. The processing station **50** preferably includes a graphical user interface on a touch-screen display for reviewing and manipulating the data and/or information. It should be appreciated that the processing station **50** may also be a stand-alone unit that is not located on the network **32**, but includes the necessary hardware to link to the communication module **48** of the patient handling device **22**.

[0039] Referring to FIG. 2, a typical room floor plan in a healthcare facility is illustrated. As shown, the room, labeled **Room 1**, includes two zones, labeled **Zone A** and **Zone B**. These zones **A, B** are also often referred to as bed bays or bed areas. The location detection system **20** of the present invention is configured to determine the particular zone in which the patient handling device **22** is located. In the embodiment of FIG. 2, two patient handling devices **22** are illustrated for positioning at a location, e.g., **Zone A** and **Zone B**, in the healthcare facility. The location detection system **20** shall only be described with reference to one of the patient handling devices **22**. Of course, it should be appreciated that the location detection system **20** is utilized to determine the specific locations of several patient handling devices **22** simultaneously throughout the health care facility. Multiple patient handling devices **22** may also be located in the same zone **A, B**.

[0040] Referring to the patient handling device **22** shown in **Zone A** of the room floor plan of FIG. 2, a locator **52** is fixed relative to the patient handling device **22**. The locator **52** is affixed to a wall of the room, a floor of the room, or a ceiling of the room. The locator **52** may also be suspended from any location in the room such as by a tether or any other restraining mechanisms or devices

adapted to maintain the locator **52** in a fixed relationship relative to the patient handling device **22**. In other words, in the embodiment of FIG. 2, the locator **52** is not designed to be mobile for transport outside of the room.

[0041] The locator **52** is programmed with a unique location identifier that corresponds to the location of the patient handling device **22**. The unique location identifier may simply be a serial number of the locator **52** that is entered into a look-up table stored in accessible memory of the processing station **50** and associated with the zone in which the locator **52** is installed.

[0041] The processing station **50**, which is remotely located relative to the patient handling device **22** and the locator **52**, receives the unique location identifier such that the location of the patient handling device **22** can be determined and monitored remotely from the patient handling device **22**. More specifically, a receiver **54** is supported by the patient handling device **22** and receives the unique location identifier corresponding to the location, and the communication module **48**, which is electronically coupled to the receiver **54**, transmits the unique location identifier of the locator **52** from the patient handling device **22** to the processing station **50**. As a result, the patient handling device **22** acts as a communication link between the locator **52** and the processing station **50**. About the same time, the communication module **48** transmits or communicates a unique ID of the patient handling device **22** to the processing station **50** such that the processing station **50** can correlate the location of the patient handling device **22** with the unique ID of the patient handling device **22**.

[0042] A separate look-up table is utilized by the processing station **50** to correlate the unique ID to a patient for which the specific patient handling device **22** is associated. The processing station **50** then correlates the unique ID and patient to the particular zone in which the specific patient handling device **22** is now located such that the software application installed on the processing station **50** can accurately manage data corresponding to the specific patient handling device **22** and the patient.

[0043] In one embodiment, the locator **52** includes at least one infrared transmitter **56** for transmitting the unique location identifier to the receiver **54** and the receiver **54** includes a housing supporting at least one infrared sensor **58** for receiving the unique location identifier from the infrared transmitter **56**. In this instance, transmitting the unique location identifier from the locator **52** to the patient handling device **22** is further defined as transmitting an infrared location signal from the at least one infrared transmitter **56** of the locator **52** to the at least one infrared sensor **58** of the receiver **54**. Those skilled in the art appreciate that other data, besides the unique location identification may also be transmitted from the infrared transmitter **56**, e.g., battery strength of a battery **60** in the locator **52**, time/date, etc.

[0044] The receiver **54** is configured to include at least one infrared transmitter **56** for transmitting a request sig-

nal to the locator **52**. Likewise, the locator **52** is configured to include at least one infrared sensor **58** to receive the request signal from the receiver **54**. The battery **60**, rechargeable or otherwise, is used to power the locator **52**. To conserve battery life, the locator **52** normally operates in a sleep mode until the request signal is received by the at least one infrared sensor **58** of the locator **52**.

[0045] Referring to the electrical schematic of FIG. 3, one embodiment of the locator **52** is shown in more detail. In this embodiment, the locator **52** includes a plurality of infrared transmitters **56** for transmitting the unique location identifier to the receiver **54**. Likewise, the locator **52** includes a plurality of infrared sensors **58** arranged in a sensor array **62** for receiving the request signal from the receiver **54**. The locator **52** also includes a microprocessor **64** electrically coupled to the sensor array **62** and the infrared transmitters **56**. The microprocessor **64** is pre-programmed with the unique location identifier that corresponds to the location of the patient handling device **22** and controls the infrared transmitters **56** to produce a signal with the unique location identifier and transmit the signal to the receiver **54** of the patient handling device **22**. The infrared transmitters **56** of the locator **52** are adapted to provide variable power transmission to minimize cross talk and maximize signal integrity. The locator **52** is also adapted to modulate light intensity from the infrared transmitters **56** to maximize noise immunity. Finally, a filter (not shown) may be used to filter the infrared signal to reduce receiver saturation and maximize signal integrity and noise immunity.

[0046] Referring to the electrical schematic of FIG. 4, one embodiment of the receiver **54** of the patient handling device **22** is shown in more detail. In this embodiment, the receiver **54** includes a plurality of infrared sensors **58** arranged in a sensor array **62** for receiving the unique location identifier from the infrared transmitters **56** thereby improving transmission of the unique location identifier. Likewise, the receiver **54** includes a plurality of infrared transmitters **56** for transmitting the request signal from the receiver **54** to the locator **52** thereby improving transmission of the request signal. The receiver **54** may also be battery powered, but is preferably powered by an AC power source used to power a control system and the CPU **44** of the patient handling device **22**. Those skilled in the art realize that the locator **52** and receiver **54** may each be implemented with a single infrared transmitter **56** and infrared sensor **58**.

[0047] Referring to FIG. 5, a process flow diagram illustrates a method of detecting the location of the patient handling device **22**. Initially, the locator **52** is in the sleep mode and awaits the request signal from the receiver **54**. In other words, the microprocessor **64** looks on a reception channel to see if the patient handling device **22** has requested location information, e.g., the unique location identifier. If the patient handling device **22** has not requested the unique location identifier, the locator **52** remains in the sleep mode. If the patient handling device **22** sends the request signal and the request signal is

properly received and understood by the locator **52**, then the location signal sends the location information, i.e., the unique location identifier on a transmission channel. Once the unique location identifier is sent, the locator **52** returns to the sleep mode to conserve battery life.

[0048] Referring to FIG. 6, a process flow diagram illustrates a method of sending the request signal to the locator **52** from the receiver **54**. The receiver **54**, which is preferably powered by an AC power source, regularly transmits the request signal to continually update the location of the patient handling device **22**. The timing of these transmissions can differ depending on whether or not the receiver **54** has recently received the location information or not. As a result, there may be multiple pre-determined delays between request signals, e.g., delay #1 and delay #2, which differ in the amount of time between transmissions of the request signal to the locator **52** on a transmission channel of the receiver **54**. Once the location information is received, the information is processed and the unique location identifier is sent on to the CPU **44** and ultimately the processing station **50** to determine the location of the patient handling device **22**.

[0049] Referring to FIG. 7, alternative location detection systems are shown with similar features to that of the previously described embodiment. In FIG. 7, the locator **52** may be one of: a radio frequency identification (RFID) tag **76** for transmitting the unique location identifier using radio frequency; an ultrasonic transmitter **80** for transmitting the unique location identifier using ultrasonic signals; an inductively coupled transmitter **84** for transmitting the unique location identifier using principles of magnetic inductive coupling; or a modulated light transmitter **88** for transmitting the unique location identifier using modulated light. It should be appreciated that in each of these embodiments, the receiver **54** is particularly adapted for receiving the specific signal types mentioned, i.e., the receiver **54** may be a RFID reader **78**, or include an ultrasonic sensor **82**, an inductively coupled sensor **86**, or a modulated light sensor **90**.

[0050] Referring to FIGS. 8-11, further alternative systems using RFID are shown. It should be appreciated that any of the systems using RFID could be active, semi-active, or passive RFID systems as is well known to those skilled in the art. In general, when a passive system is employed, each of the tags **76** described contains a transponder (not shown) with a digital memory chip (not shown) that is given or programmed with the unique location identifier. An interrogator (not shown), which is an antenna packaged with a transceiver and decoder in the RFID reader **78** emits a signal activating the RFID tags **76** so that the interrogator can read and write data to the RFID tags **76**. When the patient handling device **22** is moved into the particular zone in the room, the RFID tags **76** detect the RFID reader's activation signal. The RFID reader **78** then decodes the data, e.g., the unique location identifier, encoded in the RFID tag's digital memory chip and the data is passed to the processing station **50** as previously described.

[0051] In the embodiment of FIG. 8, the locator **52** comprises an RFID tag mat **92** that includes an array of RFID tags **76**. At least one of the tags **76** transmits the unique location identifier, or a selected set of the RFID tags **76** transmits a signal that is recognized as the unique location identifier. In this embodiment, the receiver **54** is an RFID reader **78** for receiving the signals from the RFID tags **76**. In use, the healthcare professional or other employee of the healthcare facility would first move the patient handling device **22** into position either over the RFID tag mat **92** or in close proximity to the RFID tag mat **92**. The RFID tags **76**, or at least a portion thereof, would then transmit the unique location identifier to the RFID reader **78**, which would then transmit the unique location identifier to the CPU **44** and then to the processing station **50** located on the network **32** via the communication module **48**, as previously described.

[0052] In the embodiment of FIG. 9, the locator **52** comprises an RFID swipe card **94** having at least one active or passive RFID tag **76**. The RFID swipe card **94** is tethered to a head wall **124** of the room using a tether **68**. This fixes the RFID swipe card **94** in the room relative to the patient handling device **22**. The receiver **54** is an RFID reader **78** that receives the unique location identifier from the RFID tag **76** embedded in the RFID swipe card **94**. In this embodiment, a healthcare professional would first move the patient handling device **22** into position in the particular zone in the room and then swipe the RFID swipe card **94** over the RFID reader **78** to transfer the unique location identifier from the RFID tag **76** to the RFID reader **78** and on to the processing station **50**.

[0053] In the embodiment of FIG. 10, the locator **52** comprises a magnetic RFID tag **70**. The magnetic RFID tag **70** is tethered to the head wall **124** as in FIG. 9, using a tether **68**. However, in this embodiment, the healthcare professional or other employee of the healthcare facility does not merely swipe the magnetic RFID tag **70** to transmit the unique location identifier to the RFID reader **78**. Instead, the RFID reader **78** magnetically attracts the magnetic RFID tag **70** to releasably lock the magnetic RFID tag **70** to the RFID reader **78** to ensure a complete transmission of the unique location identifier to the processing station **50** in the manner described above.

[0054] In the embodiment of FIG. 11, the locator **52** comprises an RFID tag **76** and the receiver **54** comprises an RFID reader **78** similar to FIGS. 8-10. However, this embodiment further includes a cable **72** that would be maintained at each zone **A, B**. The cable **72** interconnects a nurse call interface of the patient handling device **22** to a standard nurse call interface port **74** located at each zone **A, B**. The RFID reader **78** is integrated into the nurse call interface located on the patient handling device **22** and the RFID tag **76** is integrated into an end of the cable **72** such that when the cable **72** connects the nurse call interface on the patient handling device to the nurse call interface port **74** mounted to the head wall **124**, the RFID tag **76** would transmit the location information, e.g., unique location identifier, to the RFID reader **78** and

on to the processing station **50** located on the network **32**.

[0055] Referring to FIGS. 12-15, further alternative systems are shown. In the embodiment of FIG. 12, the locator **52** comprises a plurality of WiFi access points **96** located throughout the room and programmed with unique location identifiers for the zones in the room in which they are located. This system is capable of triangulating the room and zone location of the patient handling device **22** using the WiFi access points **96**. The receiver **54** further comprises a WiFi transceiver **95** mounted to the patient handling device **22**. The WiFi transceiver is in communication with the WiFi access points **96** to receive reference signals transmitted by the WiFi access points **96**. In some embodiments, the strength of the signal received in combination with the unique location identifiers programmed into the WiFi access points **96** could be used to triangulate the room and zone location of the patient handling device **22**. The WiFi transceiver **95** communicates the location information to the processing station **50** located on the network **32**.

[0056] In the embodiment of FIG. 13, the locator **52** comprises an ID transmitter **98** integrated into a 110 Volt AC plug **100** that transmits a reference signal to the receiver **54** located on the patient handling device **22**. In this embodiment, the receiver **54** is integrated into a power cord interface **101** to communicate with the ID transmitter **98** through a power cord **103**. The receiver **54** would then communicate the location information, e.g., unique location identifier, to the processing station **50** located on the network **32**.

[0057] In the embodiment of FIG. 14, the locator **52** comprises an Ethernet port **102** and the receiver **54** comprises an Ethernet transceiver **104** mounted to the patient handling device **22**. An Ethernet-compliant cable **106** interconnects the Ethernet transceiver **104** and the Ethernet Port **102** to send location information to the patient handling device **22**. The Ethernet transceiver **104** then communicates the location information to the processing station **50**.

[0058] In the embodiment of FIG. 15, the system utilizes a mesh network **108** with mesh network transceivers **110** to determine the location information. The mesh network **108** may be wired or wireless, preferably wireless to reduce infrastructure costs. The wireless mesh network **108** allows mesh network transceivers **110** to transmit data through one another onto the network **32** and the processing station **50**. In other words, in the wireless mesh network **108**, access points and wireless devices can organize themselves into an ad hoc network, communicating with each other to determine the fastest way to send data to the network **32**. In the wireless mesh network **108**, data hops from mesh network transceiver **110** to mesh network transceiver **110** looking for the shortest available path to the network **32** and the processing station **50**. Here, each of the patient handling devices **22** is equipped with a mesh network transceiver **110**, which acts as a node on the mesh network **108**. The location information is obtained by knowing the associ-

ation of the mesh network transceivers **110** on the patient handling devices **22** relative to the other mesh network transceivers **110** and/or a base transceiver (not shown). For instance, adjacent patient handling devices **22** in a second zone of the room, e.g., **Zone B of Room 1**, could determine the location information using the mesh network transceiver **110** on the patient handling device **22** in **Zone A of Room 1**.

[0059] Referring to FIGS. 16-19, alternative location detection systems are shown for determining the location in which the patient handling device **22** is located by separately determining first and second areas of the location. In one embodiment, the first area is the room, e.g., **Room 1**, in which the patient handling device **22** is located, and the second, subarea, is the zone in the room in which the patient handling device **22** is located, e.g., zones **A, B**. One of the previously described location detection systems may be used to determine the first area in which the patient handling device **22** is located. In this instance, the previously described systems would be enabled to only provide first area or room locations and not specific zone locations. In other words, the previously described systems would provide a first locating device, e.g., locator **52**, mesh network transceiver **54**, etc., associated with the patient handling device **22** and in communication with the processing station **50** to transmit a first unique location identifier to the processing station **50**. The first unique location identifier being associated with the first area in which the patient handling device **22** is located, but not the subarea or particular zone in which the patient handling device **22** is located.

[0060] The asset tracking system **42** of the healthcare facility could also be the first locating device used for this purpose. In this instance, each of the patient handling devices **22** would be equipped with an asset tag **114** for tracking the patient handling devices **22** in the healthcare facility with the asset tracking system **42** being adapted to provide room locations for the patient handling devices **22** and transmit those room locations to an asset tag receiver **116** on the network **32**, and on to the processing station **50**. For purposes of description, reference is made to the first locating device being the asset tracking system **42**.

[0061] The alternative location detection systems of FIGS. 16-19 provide a second locating device **109** associated with the patient handling device **22** and in electronic communication with the processing station **50** to transmit a second unique location identifier to the processing station **50**. The second unique location identifier corresponds to the subarea or zone in which the patient handling device **22** is located. Thus, the first unique location identifier provides the general vicinity in which the patient handling device **22** is located, while the second unique location identifier further refines the description of the location to pinpoint the location of the patient handling device **22**. Referring first to FIG. 16, the second locating device may be an electronic switch **118** that can be manually actuated to correspond to the ap-

propriate zone **A, B**. The switch **118** would be in communication with the network **32** and processing station **50** to identify the zone **A, B** selected.

[0062] Referring to FIGS. 17 and 18, the second locating device **109** is a sonic distance sensor **120** or a laser distance finder **122** used to determine the zone **A, B** in which the patient handling device **22** is located. In these embodiments, the sonic distance sensors **120** or laser distance finders **122** would be adapted to generally measure distances from walls **124, 125** located in the first area, e.g., **Room 1**, to further determine the position of the patient handling device **22** in the room. A look-up table could be loaded into the processing station **50** with predetermined ranges of distances provided to correspond to the different zones **A, B**. For instance, once the patient handling device **22** is wheeled or moved into room, the sonic distance sensors **120** or laser distance finder **122** may be manually or automatically operated to measure the distance from predetermined boundaries, e.g., walls **124, 125**, with the measured distances being compared to the look-up table and with a corresponding zone **A, B** selected therefrom.

[0063] Referring to FIG. 19, the second locating device is a hall-effect sensor **126** operable with a room magnet **128** or plurality of room magnets **128** located in the room to determine the zone location of the patient handling device **22**. In each of the embodiments of FIGS. 16-19, the sonic distance sensors **120**, laser distance finder **122**, and hall-effect sensor **126** would be adapted to transmit signals that communicate, either directly or indirectly, with the processing station **50** to display the room and zone location of the patient handling device **22**. In one version, the communication module **48** is in electronic communication with these second locating devices **109** and the processing station **50** to transmit the second unique location identifier from the second locating devices **109** to the processing station **50**. Again, as with the previously described embodiments, the patient handling device **22** has a unique ID and the communication module **48** communicates the unique ID to the processing station **50** such that the processing station **50** can correlate the first unique location identifier and the second unique location identifier to the patient handling device **22** to determine the room and zone location of the patient handling device **22**.

[0064] Obviously, many modifications and variations of the present invention are possible in light of the above teachings. The invention may be practiced otherwise than as specifically described within the scope of the appended claims.

Claims

1. A location detection system for a facility, comprising; a patient handling device (**22**) having a support surface for supporting a patient and being mobile for positioning at a location in the facility,

a locator (52) fixed relative to said patient handling device (22) for transmitting a unique location identifier corresponding to the location of said patient handling device(22),
 a processing station (50) remote from said patient handling device (22) and said locator (52) for receiving said unique location identifiers such that the location of said patient handling device (22) is determinable and monitorable remotely from said patient handling device (22),
 a receiver (54) mounted to said patient handling device (22) for receiving said unique location identifier from said locator (52), and
 a communication module (48) mounted to said patient handling device (22) and in communication with said receiver(54), said communication module having a unique ID for said patient handling device(22) and being adapted to transmit said unique ID and said unique location identifier received by said receiver from said patient handling device (22) to said processing station (50) such that said patient handling device acts as a communication link between said locator (52) and said processing station (50), and said processing station being adapted to receive said unique location identifier and said unique ID and correlate said unique location identifier with said unique ID and to further correlate said unique ID of said patient handling device with a patient supported by said patient handling device wherein said processing station is adapted to track said patient handling device and the patient supported thereby.

2. A location detection system as set forth in claim 1 wherein said locator (52) includes at least one infrared transmitter (56) for transmitting said unique location identifier to said receiver (54) and said receiver (54) includes at least one infrared sensor (58) for receiving said unique location identifier from said infrared transmitter (56).
3. A location detection system as set forth in claim 2 wherein said locator (52) includes a plurality of infrared transmitters, (56) for transmitting said unique location identifier to said receiver (54) and said receiver (54) includes a plurality of infrared sensors, (58) for receiving said unique location identifier from said infrared transmitters (56) thereby improving transmission of said unique location identifier.
4. A location detection system as set forth in claim 23 wherein said locator (52) includes at least one infrared sensor (58) for receiving a request signal from said receiver (54) and said receiver (54) includes at least one infrared transmitter (56) for transmitting said request signal from said receiver (54) to said locator (52).
5. A location detection system as set forth in claim 4

5
10
15
20
25
30
35
40
45
50
55

including a battery (60) for powering said locator (52) wherein said locator (52) normally operates in a sleep mode until said request signal is recovered by said at least one infrared sensor (58) of said locator (52) thereby conserving said battery.

6. A location detection system as set forth in claim 4 wherein said locator (52) includes a plurality of infrared sensors (58) for receiving said request signal from said receiver (54) and said receiver (54) includes a plurality of infrared transmitters (56) for transmitting said request signal from said receiver (54) to said locator (52) thereby improving transmission of said request signal.
7. A location detection system as set fourth in claim 1 wherein said locator (52) includes at least one radio frequency identification tag (70, 76) for transmitting said unique location identifier to said receiver (54) using radio frequency.
8. A location detection system as set forth in claim 7 wherein said locator (52) includes a plurality of radio frequency identification tags (76) for transmitting said unique location identifier to said receiver (54).
9. A location detection system as set forth in claim 7 including a nurse call interface port (74) and a cable (72) interconnecting said nurse call interface port (74) and said patient handling device (22) with said at least one radio frequency identification tag (76) mounted to one end of said cable (72).
10. A location detection system as set forth in claim 7 including a tether (68) connected to said locator (52) for fixing said radio frequency identification tag (76) at the location.
11. A location detection system as set forth in claim 7 wherein said at least one radio frequency identification tag (70, 76) is further defined as a magnetic radio frequency identification tag (70) having a magnet for coupling said magnetic radio frequency identification tag (70) to said receiver (54) to transmit said unique location identifier to said receiver (54).
12. A location detection system as set forth in claim 1 wherein said locator (52) includes an ultrasonic transmitter (80) and said receiver (54) includes all ultrasonic sensor (82).
13. A location detection system as set forth in claim 1 wherein said locator (52) includes a magnetic inductive coupled transmitter (84) and said receiver (54) includes a magnetic inductive coupled sensor (86).
14. A location detection system as set forth in claim 1 wherein said locator (52) includes a modulated light

- transmitter (88) and said receiver (54) includes a modulated light sensor (90).
- 15.** A location detection system as set forth in claim 1 wherein said locator (52) is further defined as a plurality of WiFi access points (96) and said receiver (54) comprises a WiFi transceiver (95). 5
- 16.** A location detection system as set forth in claim 1 wherein said locator (52) includes an AC plug (100) for powering said patient handling device (22) and said locator (52) includes a transmitter (98) mounted in said AC plug (100) for transmitting said unique location identifier to said receiver (54). 10
- 17.** A location detection system as set forth in claim 1 wherein said locator (52) includes an Ethernet port (102) for transmitting said unique location identifier to said receiver (54) over an Ethernet compliant cable (106). 15
- 18.** A method of detecting a location of a patient and a patient handling device (22) having a support surface for supporting the patient and being adapted to be transported throughout a facility, comprising; transporting the patient handling device (22) to the location in the facility, the patient handling device (22) having a unique ID associated therewith, transmitting a unique location identifier corresponding to the location of the patient handling device (22) from a locator (52) fixed at the location to a receiver (54) mounted to the patient handling device (22), transmitting the unique location identifier and the unique ID from the patient handling device (22) to a processing station remote (50) from the patient handling device (22), correlating the unique location identifier with the unique ID, and correlating the unique ID with a patient supported by the patient handling device (22), such that the location of the patient handling device (22) and the patient can be determined and monitored remotely from the patient handling device (22). 25 30 35 40
- 19.** A method as set forth in claim 8 wherein transmitting the unique location identifier from the locator (52) to the patient handling device (22) is further defined as transmitting an infrared location signal from an infrared transmitter (56) of the locator (52) to an infrared sensor (58) of the receiver (54). 45 50
- 20.** A method as set forth in claim 19 wherein transmitting the unique location identifier from the patient handling device (22) to the processing station (50) is further defined as transmitting the unique location identifier from a communication module (48) supported by the patient handling device (22) to the processing station (50) such that the patient handling device (22) acts as a communication link between the locator (52) and the processing station (50). 55
- 21.** A method as set forth in claim 20 including transmitting a request signal from the patient handling device (22) to the locator (52) to wake the locator (52) from a sleep mode.
- 22.** A method as set forth in claim 21 wherein transmitting the request signal includes transmitting an infrared request signal from an infrared transmitter (56) of the receiver (54) and receiving the infrared request signal at an infrared sensor (58) of the locator (52) after transporting the patient handling device (22) to the location.
- 23.** A method as set forth in claim wherein transmitting the infrared location signal from the infrared transmitter (56) of the locator (52) to the infrared sensor (58) of the receiver (54) is further defined as transmitting the infrared location signal upon receiving the infrared request signal at the locator (52).
- 24.** A method as set forth in claim 19 including varying power transmission from the infrared transmitter (56) to minimize cross talk and maximize signal integrity.
- 25.** A method as set forth in claim 19 including modulating light intensity from the infrared transmitter (56) to maximize noise immunity.
- 26.** A method as set forth in claim 19 including filtering the infrared signal to reduce receiver (54) saturation and maximize signal integrity and noise immunity.
- 27.** The location detection system according to claim 1, further comprising a second locating device (109) associated with said patient handling device (22) for transmitting a second unique location identifier from said patient handling device (22) to said processing station (50) wherein said first unique location identifier corresponds to a first area of the location and said second unique location identifier corresponds to a second area of the location different than said first area.
- 28.** A location detection system as set forth in claim 27 wherein said first area is further defined as a room (Room 1) in the facility and said second area is further defined as a zone (A, B) in the room (Room 1).
- 29.** A location detection system as set forth in claim 27 wherein said second locating device (109) is further defined as at least one sonic distance sensor (120) for sensing boundaries (124, 125) at the location to determine said second area.
- 30.** A location detection system as set forth in claim 27

wherein said second locating device is further defined as a laser distance finder (122) for determining distances from boundaries (124, 125) at the location to determine said second area.

31. A location detection system as set forth in claim 27 including a magnet (128) fixed relative to said patient handling device (22) at the location wherein said second locating device (109) is further defined as a hall effect sensor (126) for detecting said magnet (128) to determine said second area.

32. A location detection system as set forth in claim 27 including a communication module (48) in electronic communication with said second locating device (109) and said processing station (50) for transmitting said second unique location identifier from said second locating device (109) to said processing station (50).

33. A location detection system as set forth in claim 32 wherein said patient handling device (22) has a unique ID and said communication module (48) communicates both said unique ID and said second location identifier to said processing station (50) such that said processing station (50) can correlate said first unique location identifier and said second unique location identifier to said patient handling device (22) to determine said first and second areas of said patient handling device (22).

34. The method according to claim 18, further, comprising; determining a first area location of the patient handling device (22) from the unique location identifier with the unique location identifier forming a first unique location identifier, and transmitting a second unique location identifier from the patient handling device (22) to the processing station (50) wherein the first unique location identifier corresponds to a first area of the location and the second unique location identifier corresponds to a second area of the location different than the first area.

Patentansprüche

1. Standortdetektionssystem für eine Einrichtung, das Folgendes umfasst:

eine Patientenhandhabungsvorrichtung (22) mit einer Auflagefläche zum Tragen eines Patienten, die zum Positionieren an einem Ort in der Einrichtung beweglich ist, einen Positionsgeber (52), der relativ zu der genannten

Patientenhandhabungsvorrichtung (22) zum Senden einer eindeutigen Positionskennung befestigt ist, die dem Standort der genannten Patientenhandhabungsvorrichtung (22) entspricht,

eine Verarbeitungsstation (50) fern von der genannten

Patientenhandhabungsvorrichtung (22) und dem genannten Positionsgeber (52) zum Empfangen der genannten eindeutigen Standortkennung, so dass der Standort der genannten Patientenhandhabungsvorrichtung (22) fern von der genannten Patientenhandhabungsvorrichtung (22) ermittelt und überwacht werden kann,

einen Empfänger (54), der an der genannten Patientenhandhabungsvorrichtung (22) montiert ist, zum Empfangen der genannten eindeutigen Standortkennung von dem genannten Positionsgeber (52), und

ein Kommunikationsmodul (48), das an der genannten

Patientenhandhabungsvorrichtung (22) montiert ist und mit dem genannten Empfänger (54) kommuniziert, wobei das genannte Kommunikationsmodul eine eindeutige ID für die genannte Patientenhandhabungsvorrichtung (22) und die Aufgabe hat, die genannte eindeutige ID und die genannte von dem genannten Empfänger empfangene eindeutige Standortkennung von der genannten Patientenhandhabungsvorrichtung (22) zu der genannten Verarbeitungsstation (50) zu senden, so dass die genannte Patientenhandhabungsvorrichtung als Kommunikationsverbindung zwischen dem genannten Positionsgeber (52) und der genannten Verarbeitungsstation (50) dient, und wobei die genannte Verarbeitungsstation die Aufgabe hat, die genannte eindeutige Standortkennung und die genannte eindeutige ID zu empfangen und die genannte eindeutige Standortkennung mit der genannten eindeutigen ID zu korrelieren und ferner die genannte eindeutige ID der genannten Patientenhandhabungsvorrichtung mit einem Patienten zu korrelieren, der von der genannten Patientenhandhabungsvorrichtung getragen wird, wobei die genannte Verarbeitungsstation die Aufgabe hat, die genannte Patientenhandhabungsvorrichtung und den davon getragenen Patienten zu verfolgen.

2. Standortdetektionssystem nach Anspruch 1, wobei der genannte Positionsgeber (52) wenigstens einen Infrarotsender (56) zum Senden der genannten eindeutigen Standortkennung zu dem genannten Empfänger (54) aufweist und der genannte Empfänger (54) wenigstens einen Infrarotsensor (58) zum Empfangen der genannten eindeutigen Standortkennung

- nung von dem genannten Infrarotsender (56) aufweist.
3. Standortdetektionssystem nach Anspruch 2, wobei der genannte Positionsgeber (52) mehrere Infrarotsender (56) zum Senden der genannten eindeutigen Standortkennung zu dem genannten Empfänger (54) aufweist und der genannte Empfänger (54) mehrere Infrarotsensoren (58) zum Empfangen der genannten eindeutigen Standortkennung von den genannten Infrarotsendern (56) aufweist, wodurch die Übertragung der genannten eindeutigen Standortkennung verbessert wird. 5
 4. Standortdetektionssystem nach Anspruch 23 [sic], wobei der genannte Positionsgeber (52) wenigstens einen Infrarotsensor (58) zum Empfangen eines Anforderungssignals von dem genannten Empfänger (54) aufweist und der genannte Empfänger (54) wenigstens einen Infrarotsender (56) zum Senden des genannten Anforderungssignals von dem genannten Empfänger (54) zu dem genannten Positionsgeber (52) aufweist. 10
 5. Standortdetektionssystem nach Anspruch 4 mit einer Batterie (60) zum Speisen des genannten Positionsgebers (52), wobei der genannte Positionsgeber (52) normalerweise in einem Schlummermodus arbeitet, bis das genannte Anforderungssignal von dem genannten wenigstens einen Infrarotsensor (58) des genannten Positionsgebers (52) gewonnen wird, wodurch die genannte Batterie geschont wird. 15
 6. Standortdetektionssystem nach Anspruch 4, wobei der genannte Positionsgeber (52) mehrere Infrarotsensoren (58) zum Empfangen des genannten Anforderungssignals von dem genannten Empfänger (54) aufweist und der genannte Empfänger (54) mehrere Infrarotsender (56) zum Senden des genannten Anforderungssignals von dem genannten Empfänger (54) zu dem genannten Positionsgeber (52) aufweist, wodurch die Übertragung des genannten Anforderungssignals verbessert wird. 20
 7. Standortdetektionssystem nach Anspruch 1, wobei der genannte Positionsgeber (52) wenigstens ein Funkfrequenz-Identifikationsetikett (70, 76) zum Senden der genannten eindeutigen Standortkennung zu dem genannten Empfänger (54) mit Funkfrequenz aufweist. 25
 8. Standortdetektionssystem nach Anspruch 7, wobei der genannte Positionsgeber (52) mehrere Funkfrequenz-Identifikationsetiketten (76) zum Senden der genannten eindeutigen Standortkennung zu dem genannten Empfänger (54) aufweist. 30
 9. Standortdetektionssystem nach Anspruch 7 mit ei-
- nem Krankenpflegerruf-Schnittstellenanschluss (74) und einem Kabel (72), das den genannten Krankenpflegerruf-Schnittstellenanschluss (74) mit der genannten Patientenhandhabungsvorrichtung (22) verbindet, wobei das genannte wenigstens eine Funkfrequenz-Identifikationsetikett (76) an einem Ende des genannten Kabels (72) montiert ist. 35
 10. Standortdetektionssystem nach Anspruch 7 mit einer Schnur (68), die mit dem genannten Positionsgeber (52) verbunden ist, um das genannte Funkfrequenz-Identifikationsetikett (76) an dem Ort zu befestigen. 40
 11. Standortdetektionssystem nach Anspruch 7, wobei das genannte wenigstens eine Funkfrequenz-Identifikationsetikett (70, 76) ferner als magnetisches Funkfrequenz-Identifikationsetikett (70) mit einem Magnet zum Koppeln des genannten magnetischen Funkfrequenz-Identifikationsetiketts (70) an dem genannten Empfänger (54) definiert ist, um die genannte eindeutige Standortkennung zu dem genannten Empfänger (54) zu senden. 45
 12. Standortdetektionssystem nach Anspruch 1, wobei der genannte Positionsgeber (52) einen Ultraschallsender (80) aufweist und der genannte Empfänger (54) einen Ultraschallsensor (82) aufweist. 50
 13. Standortdetektionssystem nach Anspruch 1, wobei der genannte Positionsgeber (52) einen magnetischen induktiv gekoppelten Sender (84) aufweist und der genannte Empfänger (54) einen magnetischen induktiv gekoppelten Sensor (86) aufweist. 55
 14. Standortdetektionssystem nach Anspruch 1, wobei der genannte Positionsgeber (52) einen modulierten Lichtsender (88) aufweist und der genannte Empfänger (54) einen modulierten Lichtsensor (90) aufweist. 60
 15. Standortdetektionssystem nach Anspruch 1, wobei der genannte Positionsgeber (52) ferner als eine Mehrzahl von WiFi-Zugriffspunkten (96) definiert ist und der genannte Empfänger (54) einen WiFi-Sender-Empfänger (95) umfasst. 65
 16. Standortdetektionssystem nach Anspruch 1, wobei der genannte Positionsgeber (52) einen Wechselstromstecker (100) zum Speisen der genannten Patientenhandhabungsvorrichtung (22) aufweist und der genannte Positionsgeber (52) einen Sender (98) aufweist, der in dem genannten Wechselstromstecker (100) montiert ist, um die genannte eindeutige Standortkennung zu dem genannten Empfänger (54) zu senden. 70
 17. Standortdetektionssystem nach Anspruch 1, wobei

- der genannte Positionsgeber (52) einen Ethernet-Anschluss (102) zum Senden der genannten eindeutigen Standortkennung zu dem genannten Empfänger (54) über ein Ethernet-fähiges Kabel (106) aufweist.
- 18.** Verfahren zum Detektieren eines Standorts eines Patienten und einer Patientenhandhabungsvorrichtung (22) mit einer Auflagefläche zum Tragen des Patienten und so ausgestaltet, dass sie durch eine Einrichtung transportiert werden kann, das Folgendes beinhaltet:
- Transportieren der Patientenhandhabungsvorrichtung (22) zu dem Standort in der Einrichtung, wobei eine eindeutige ID mit der Patientenhandhabungsvorrichtung (22) assoziiert ist, Senden einer eindeutigen Standortkennung, die dem Standort der Patientenhandhabungsvorrichtung (22) entspricht, von einem an dem Standort befestigten Positionsgeber (52) zu einem an der Patientenhandhabungsvorrichtung (22) montierten Empfänger (54), Senden der eindeutigen Standortkennung und der eindeutigen ID von der Patientenhandhabungsvorrichtung (22) zu einer Verarbeitungsstation (50) fern von der Patientenhandhabungsvorrichtung (22), Korrelieren der eindeutigen Standortkennung mit der eindeutigen ID, und Korrelieren der eindeutigen ID mit einem von der Patientenhandhabungsvorrichtung (22) getragenen Patienten, so dass der Standort der Patientenhandhabungsvorrichtung (22) und des Patienten fern von der Patientenhandhabungsvorrichtung (22) ermittelt und überwacht werden kann.
- 19.** Verfahren nach Anspruch 18, wobei das Senden der eindeutigen Standortkennung vom Positionsgeber (52) zur Patientenhandhabungsvorrichtung (22) ferner als das Senden eines Infrarotstandortsignals von einem Infrarotsender (56) des Positionsgebers (52) zu einem Infrarotsensor (58) des Empfängers (54) definiert ist.
- 20.** Verfahren nach Anspruch 19, wobei das Senden der eindeutigen Standortkennung von der Patientenhandhabungsvorrichtung (22) zur Verarbeitungsstation (50) ferner als das Senden der eindeutigen Standortkennung von einem von der Patientenhandhabungsvorrichtung (22) getragenen Kommunikationsmodul (48) zu der Verarbeitungsstation (50) definiert ist, so dass die Patientenhandhabungsvorrichtung (22) als Kommunikationsverbindung zwischen dem Positionsgeber (52) und der Verarbeitungsstation (50) dient.
- 21.** Verfahren nach Anspruch 20, das das Senden eines Anforderungssignals von der Patientenhandhabungsvorrichtung (22) zum Positionsgeber (52) beinhaltet, um den Positionsgeber (52) aus einem Schlummermodus aufzuwecken.
- 22.** Verfahren nach Anspruch 21, wobei das Senden des Anforderungssignals das Senden eines Infrarotanforderungssignals von einem Infrarotsender (56) des Empfängers (54) und das Empfangen des Infrarotanforderungssignals an einem Infrarotsensor (58) des Positionsgebers (52) nach dem Transportieren der Patientenhandhabungsvorrichtung (22) zu dem Standort beinhaltet.
- 23.** Verfahren nach Anspruch 22, wobei das Senden des Infrarotstandortsignals vom Infrarotsender (56) des Positionsgebers (52) zum Infrarotsensor (58) des Empfängers (54) ferner als das Senden des Infrarotstandortsignals nach dem Empfangen des Infrarotanforderungssignals am Positionsgeber (52) definiert ist.
- 24.** Verfahren nach Anspruch 19, das das Variieren der Leistungsübertragung vom Infrarotsender (56) beinhaltet, um Übersprechen zu minimieren und Signalintegrität zu maximieren.
- 25.** Verfahren nach Anspruch 19, das das Modulieren von Lichtintensität vom Infrarotsender (56) beinhaltet, um Störfestigkeit zu maximieren.
- 26.** Verfahren nach Anspruch 19, das das Filtern des Infrarotsignals beinhaltet, um Sättigung des Empfängers (54) zu reduzieren und Signalintegrität und Störfestigkeit zu maximieren.
- 27.** Standortdetektionssystem nach Anspruch 1, das ferner Folgendes umfasst:
- eine zweite Positionsgabevorrichtung (109), die mit der genannten Patientenhandhabungsvorrichtung (22) assoziiert ist, um eine zweite eindeutige Standortkennung von der genannten Patientenhandhabungsvorrichtung (22) zu der genannten Verarbeitungsstation (50) zu senden, wobei die genannte erste eindeutige Standortkennung einem ersten Bereich des Standorts entspricht und die genannte zweite eindeutige Standortkennung einem zweiten Bereich des Standorts entspricht, der sich von dem genannten ersten Bereich unterscheidet.
- 28.** Standortdetektionssystem nach Anspruch 27, wobei der genannte erste Bereich ferner als ein Raum (Raum 1) in der Einrichtung definiert ist und der genannte zweite Bereich ferner als eine Zone (A, B) in dem Raum (Raum 1) definiert ist.

29. Standortdetektionssystem nach Anspruch 27, wobei die genannte zweite Positionsgabevorrichtung (109) ferner als wenigstens ein Schalldistanzsensor (120) zum Erfassen von Grenzen (124, 125) an dem Standort definiert ist, um den genannten zweiten Bereich zu ermitteln. 5
30. Standortdetektionssystem nach Anspruch 27, wobei die genannte zweite Positionsgabevorrichtung ferner als ein Laserdistanzmesser (122) zum Ermitteln von Distanzen von Grenzen (124, 125) an dem Standort definiert ist, um den genannten zweiten Bereich zu ermitteln. 10
31. Standortdetektionssystem nach Anspruch 27 mit einem Magnet (128), der relativ zu der genannten Patientenhandhabungsvorrichtung (22) an dem Standort befestigt ist, wobei die genannte zweite Positionsgabevorrichtung (109) ferner als Hall-Effekt-Sensor (126) zum Detektieren des genannten Magnets (128) definiert ist, um den genannten zweiten Bereich zu ermitteln. 15 20
32. Standortdetektionssystem nach Anspruch 27 mit einem Kommunikationsmodul (48) in elektronischer Kommunikation mit der genannten zweiten Positionsgabevorrichtung (109) und der genannten Verarbeitungsstation (50) zum Senden der genannten zweiten eindeutigen Standortkennung von der genannten zweiten Positionsgabevorrichtung (109) zu der genannten Verarbeitungsstation (50). 25 30
33. Standortdetektionssystem nach Anspruch 32, wobei die genannte Patientenhandhabungsvorrichtung (22) eine eindeutige ID hat und das genannte Kommunikationsmodul (48) sowohl die genannte eindeutige ID als auch die genannte zweite Standortkennung zu der genannten Verarbeitungsstation (50) übermittelt, so dass die genannte Verarbeitungsstation (50) die genannte erste eindeutige Standortkennung und die genannte zweite eindeutige Standortkennung auf die genannte Patientenhandhabungsvorrichtung (22) korrelieren kann, um den genannten ersten und zweiten Bereich der genannten Patientenhandhabungsvorrichtung (22) zu ermitteln. 35 40 45
34. Verfahren nach Anspruch 18, das ferner Folgendes beinhaltet: 50
- Ermitteln des Ortes eines ersten Bereichs der Patientenhandhabungsvorrichtung (22) von der eindeutigen Standortkennung, wobei die eindeutige Standortkennung eine erste eindeutige Standortkennung bildet, und 55
- Senden einer zweiten eindeutigen Standortkennung von der Patientenhandhabungsvorrichtung (22) zur Verarbeitungsstation (50), wobei die erste eindeutige Standortkennung einem er-

sten Bereich des Standorts entspricht und die zweite eindeutige Standortkennung einem zweiten Bereich des Standorts entspricht, der sich von dem ersten Bereich unterscheidet.

Revendications

1. Un système de détection d'emplacement pour un établissement, comprenant :

un dispositif de manipulation de patient (22) possédant une surface d'appui destinée à soutenir un patient et étant mobile de façon à le positionner à un emplacement dans l'établissement, un localisateur (52) fixe par rapport audit dispositif de manipulation de patient (22) destiné à transmettre un identifiant d'emplacement unique correspondant à l'emplacement dudit dispositif de manipulation de patient (22), une station de traitement (50) située à distance dudit dispositif de manipulation de patient (22) et dudit localisateur (52) destinée à recevoir ledit identifiant d'emplacement unique de sorte que l'emplacement dudit dispositif de manipulation de patient (22) puisse être déterminé et surveillé à distance dudit dispositif de manipulation de patient (22),

un récepteur (54) monté sur ledit dispositif de manipulation de patient (22) destiné à recevoir ledit identifiant d'emplacement unique provenant dudit localisateur (52), et

un module de communication (48) monté sur ledit dispositif de manipulation de patient (22) et en communication avec ledit récepteur (54) ledit module de communication possédant un identifiant unique pour ledit dispositif de manipulation de patient (22) et étant adapté de façon à transmettre ledit identifiant unique et ledit identifiant d'emplacement unique reçus par ledit récepteur dudit dispositif de manipulation de patient (22) à ladite station de traitement (50) de sorte que ledit dispositif de manipulation de patient remplisse une fonction de liaison de communication entre ledit localisateur (52) et ladite station de traitement (50), et ladite station de traitement étant adaptée de façon à recevoir ledit identifiant d'emplacement unique et ledit identifiant unique et de façon à corrélérer ledit identifiant d'emplacement unique avec ledit identifiant unique et de façon à corrélérer en outre ledit identifiant unique dudit dispositif de manipulation de patient avec un patient soutenu par ledit dispositif de manipulation de patient, où ladite station de traitement est adaptée de façon à suivre ledit dispositif de manipulation de patient et ledit patient soutenu par celui-ci.

2. Un système de détection d'emplacement selon la Revendication 1 où ledit localisateur (52) comprend au moins un émetteur à infrarouge (56) destiné à transmettre ledit identifiant d'emplacement unique audit récepteur (54) et ledit récepteur (54) comprend au moins un capteur à infrarouge (58) destiné à recevoir ledit identifiant d'emplacement unique provenant dudit émetteur à infrarouge (56).
3. Un système de détection d'emplacement selon la Revendication 2 où ledit localisateur (52) comprend une pluralité d'émetteurs à infrarouge (56) destinés à transmettre ledit identifiant d'emplacement unique audit récepteur (54) et ledit récepteur (54) comprend une pluralité de capteurs à infrarouge (58) destinés à recevoir ledit identifiant d'emplacement unique provenant desdits émetteurs à infrarouge (56) améliorant ainsi la transmission dudit identifiant d'emplacement unique.
4. Un système de détection d'emplacement selon la Revendication 23 *[sic]* où ledit localisateur (52) comprend au moins un capteur à infrarouge (58) destiné à recevoir un signal de demande provenant dudit récepteur (54) et ledit récepteur (54) comprend au moins un émetteur à infrarouge (56) destiné à transmettre ledit signal de demande provenant dudit récepteur (54) audit localisateur (52).
5. Un système de détection d'emplacement selon la Revendication 4 comprenant une batterie (60) destinée à alimenter ledit localisateur (52) où ledit localisateur (52) fonctionne normalement en mode veille jusqu'à ce que ledit signal de demande soit récupéré par ledit au moins un capteur à infrarouge (58) dudit localisateur (52) économisant ainsi ladite batterie.
6. Un système de détection d'emplacement selon la Revendication 4 où ledit localisateur (52) comprend une pluralité de capteurs à infrarouge (58) destinés à recevoir ledit signal de demande provenant dudit récepteur (54) et ledit récepteur (54) comprend une pluralité d'émetteurs à infrarouge (56) destinés à transmettre ledit signal de demande provenant dudit récepteur (54) audit localisateur (52) améliorant ainsi la transmission dudit signal de demande.
7. Un système de détection d'emplacement selon la Revendication 1 où ledit localisateur (52) comprend au moins une étiquette d'identification par radiofréquence (70, 76) destinée à transmettre ledit identifiant d'emplacement unique audit récepteur (54) au moyen d'un signal radio.
8. Un système de détection d'emplacement selon la Revendication 7 où ledit localisateur (52) comprend une pluralité d'étiquettes d'identification par radiofréquence (76) destinées à transmettre ledit identifiant d'emplacement unique audit récepteur (54).
9. Un système de détection d'emplacement selon la Revendication 7 comprenant un port d'interface d'appel infirmier (74) et un câble (72) interconnectant ledit port d'interface d'appel infirmier (74) et ledit dispositif de manipulation de patient (22) à ladite au moins une étiquette d'identification par radiofréquence (76) montée à une extrémité dudit câble (72).
10. Un système de détection d'emplacement selon la Revendication 7 comprenant une amarre (68) raccordée audit localisateur (52) de façon à fixer ladite étiquette d'identification par radiofréquence (76) à l'emplacement.
11. Un système de détection d'emplacement selon la Revendication 7 où ladite au moins une étiquette d'identification par radiofréquence (70, 76) est définie en outre sous la forme d'une étiquette d'identification par radiofréquence magnétique (70) possédant un aimant destiné à coupler ladite étiquette d'identification par radiofréquence magnétique (70) audit récepteur (54) de façon à transmettre ledit identifiant d'emplacement unique audit récepteur (54).
12. Un système de détection d'emplacement selon la Revendication 1 où ledit localisateur (52) comprend un émetteur à ultrasons (80) et ledit récepteur (54) comprend un capteur à ultrasons (82).
13. Un système de détection d'emplacement selon la Revendication 1 où ledit localisateur (52) comprend un émetteur à induction magnétique (84) et ledit récepteur (54) comprend un capteur à induction magnétique (86).
14. Un système de détection d'emplacement selon la Revendication 1 où ledit localisateur (52) comprend un émetteur de lumière modulée (88) et ledit récepteur (54) comprend un capteur de lumière modulée (90).
15. Un système de détection d'emplacement selon la Revendication 1 où ledit localisateur (52) est défini en outre sous la forme d'une pluralité de points d'accès Wi-Fi (96) et ledit récepteur (54) comprend un émetteur-récepteur Wi-Fi (95).
16. Un système de détection d'emplacement selon la Revendication 1 où ledit localisateur (52) comprend une prise de courant alternatif (100) destinée à alimenter ledit dispositif de manipulation de patient (22) et ledit localisateur (52) comprend un émetteur (98) monté sur ladite prise de courant alternatif (100) de façon à transmettre ledit identifiant d'emplacement unique audit récepteur (54).

17. Un système de détection d'emplacement selon la Revendication 1 où ledit localisateur (52) comprend un port Ethernet (102) destiné à transmettre ledit identifiant d'emplacement unique audit récepteur (54) par un câble conforme à la norme Ethernet (106). 5
18. Un procédé de détection d'un emplacement d'un patient et d'un dispositif de manipulation de patient (22) possédant une surface d'appui destinée à soutenir le patient et étant adapté de façon à être transporté dans un établissement, comprenant : 10
- le transport du dispositif de manipulation de patient (22) à l'emplacement dans l'établissement, le dispositif de manipulation de patient (22) possédant un identifiant unique associé à celui-ci, la transmission d'un identifiant d'emplacement unique correspondant à l'emplacement du dispositif de manipulation de patient (22) provenant d'un localisateur (52) fixé à l'emplacement vers un récepteur (54) monté sur le dispositif de manipulation de patient (22), 15
- la transmission de l'identifiant d'emplacement unique et de l'identifiant unique provenant du dispositif de manipulation de patient (22) à une station de traitement (50) située à distance du dispositif de manipulation de patient (22), 20
- la corrélation de l'identifiant d'emplacement unique avec l'identifiant unique, 25
- et
- la corrélation de l'identifiant unique avec un patient soutenu par ledit dispositif de manipulation de patient (22), de sorte que l'emplacement du dispositif de manipulation de patient (22) et du patient puissent être déterminés et surveillés à distance à partir du dispositif de manipulation de patient (22). 30
19. Un procédé selon la Revendication 18 où la transmission de l'identifiant d'emplacement unique provenant du localisateur (52) au dispositif de manipulation de patient (22) est définie en outre comme la transmission d'un signal de localisation à infrarouge provenant d'un émetteur à infrarouge (56) du localisateur (52) vers un capteur à infrarouge (58) du récepteur (54). 35
20. Un procédé selon la Revendication 19 où la transmission de l'identifiant d'emplacement unique provenant du dispositif de manipulation de patient (22) à la station de traitement (50) est défini en outre sous la forme de la transmission de l'identifiant d'emplacement unique d'un module de communication (48) pris en charge par le dispositif de manipulation de patient (22) à la station de traitement (50) de sorte que le dispositif de manipulation de patient (22) remplisse une fonction de liaison de communication entre le localisateur (52) et la station de traitement (50). 40
21. Un procédé selon la Revendication 20 comprenant la transmission d'un signal de demande du dispositif de manipulation de patient (22) au localisateur (52) de façon à sortir le localisateur (52) d'un mode veille. 45
22. Un procédé selon la Revendication 21 où la transmission du signal de demande comprend la transmission d'un signal de demande à infrarouge provenant d'un émetteur à infrarouge (56) du récepteur (54) et la réception du signal de demande à infrarouge sur un capteur à infrarouge (58) du localisateur (52) après le transport du dispositif de manipulation de patient (22) à l'emplacement. 50
23. Un procédé selon la Revendication 22 où la transmission du signal de localisation à infrarouge provenant de l'émetteur à infrarouge (56) du localisateur (52) au capteur à infrarouge (58) du récepteur (54) est définie en outre sous la forme de la transmission du signal de localisation à infrarouge après la réception du signal de demande à infrarouge sur le localisateur (52). 55
24. Un procédé selon la Revendication 19 comprenant une variation de la transmission de puissance provenant de l'émetteur à infrarouge (56) de façon à minimiser la diaphonie et à maximiser l'intégrité du signal.
25. Un procédé selon la Revendication 19 comprenant une modulation de l'intensité lumineuse provenant de l'émetteur à infrarouge (56) de façon à maximiser l'immunité au bruit.
26. Un procédé selon la Revendication 19 comprenant un filtrage du signal à infrarouge de façon à réduire la saturation du récepteur (54) et à maximiser l'intégrité du signal et l'immunité au bruit.
27. Le système de détection d'emplacement selon la Revendication 1 comprenant en outre un deuxième dispositif de localisation (109) associé audit dispositif de manipulation de patient (22) destiné à transmettre un deuxième identifiant d'emplacement unique provenant dudit dispositif de manipulation de patient (22) à ladite station de traitement (50) où ledit premier identifiant d'emplacement unique correspond à une première zone de l'emplacement et ledit deuxième identifiant d'emplacement unique correspond à une deuxième zone de l'emplacement différente de ladite première zone.
28. Un système de détection d'emplacement selon la Revendication 27 où ladite première zone est définie en outre en tant qu'une salle (Salle 1) de l'établissement et ladite deuxième zone est définie en outre en

tant qu'une zone (A, B) de la salle (Salle 1).

- 29.** Un système de détection d'emplacement selon la Revendication 27 où ledit deuxième dispositif de localisation (109) est défini en outre sous la forme d'au moins un capteur de distance acoustique (120) destiné à détecter des limites (124, 125) à l'emplacement de façon à déterminer ladite deuxième zone. 5
- 30.** Un système de détection d'emplacement selon la Revendication 27 où ledit deuxième dispositif de localisation est défini en outre sous la forme d'une télémètre laser (122) destiné à déterminer des distances à partir de limites (124, 125) à l'emplacement de façon à déterminer ladite deuxième zone. 10 15
- 31.** Un système de détection d'emplacement selon la Revendication 27 comprenant un aimant (128) fixe par rapport audit dispositif de manipulation de patient (22) à l'emplacement, où ledit deuxième dispositif de localisation (109) est défini en outre sous la forme d'un capteur à effet Hall (126) destiné à détecter ledit aimant (128) de façon à déterminer ladite deuxième zone. 20 25
- 32.** Un système de détection d'emplacement selon la Revendication 27 comprenant un module de communication (48) en communication électronique avec ledit deuxième dispositif de localisation (109) et ladite station de traitement (50) de façon à transmettre ledit deuxième identifiant d'emplacement unique provenant dudit deuxième dispositif de localisation (109) à ladite station de traitement (50). 30
- 33.** Un système de détection d'emplacement selon la Revendication 32 où ledit dispositif de manipulation de patient (22) possède un identifiant unique et ledit module de communication (48) communique à la fois ledit identifiant unique et ledit deuxième identifiant d'emplacement à ladite station de traitement (50) de sorte que ladite station de traitement (50) puisse corréler ledit premier identifiant d'emplacement unique et ledit deuxième identifiant d'emplacement unique vers ledit dispositif de manipulation de patient (22) de façon à déterminer lesdites première et deuxième zones dudit dispositif de manipulation de patient (22). 35 40 45
- 34.** Le procédé selon la Revendication 18 comprenant en outre : 50
- la détermination d'un premier emplacement de zone du dispositif de manipulation de patient (22) à partir de l'identifiant d'emplacement unique avec l'identifiant d'emplacement unique formant un premier identifiant d'emplacement unique, et 55
- la transmission d'un deuxième identifiant d'em-

placement unique provenant du dispositif de manipulation de patient (22) à la station de traitement (50) où le premier identifiant d'emplacement unique correspond à une première zone de l'emplacement et le deuxième identifiant d'emplacement unique correspond à une deuxième zone de l'emplacement différente de la première zone.

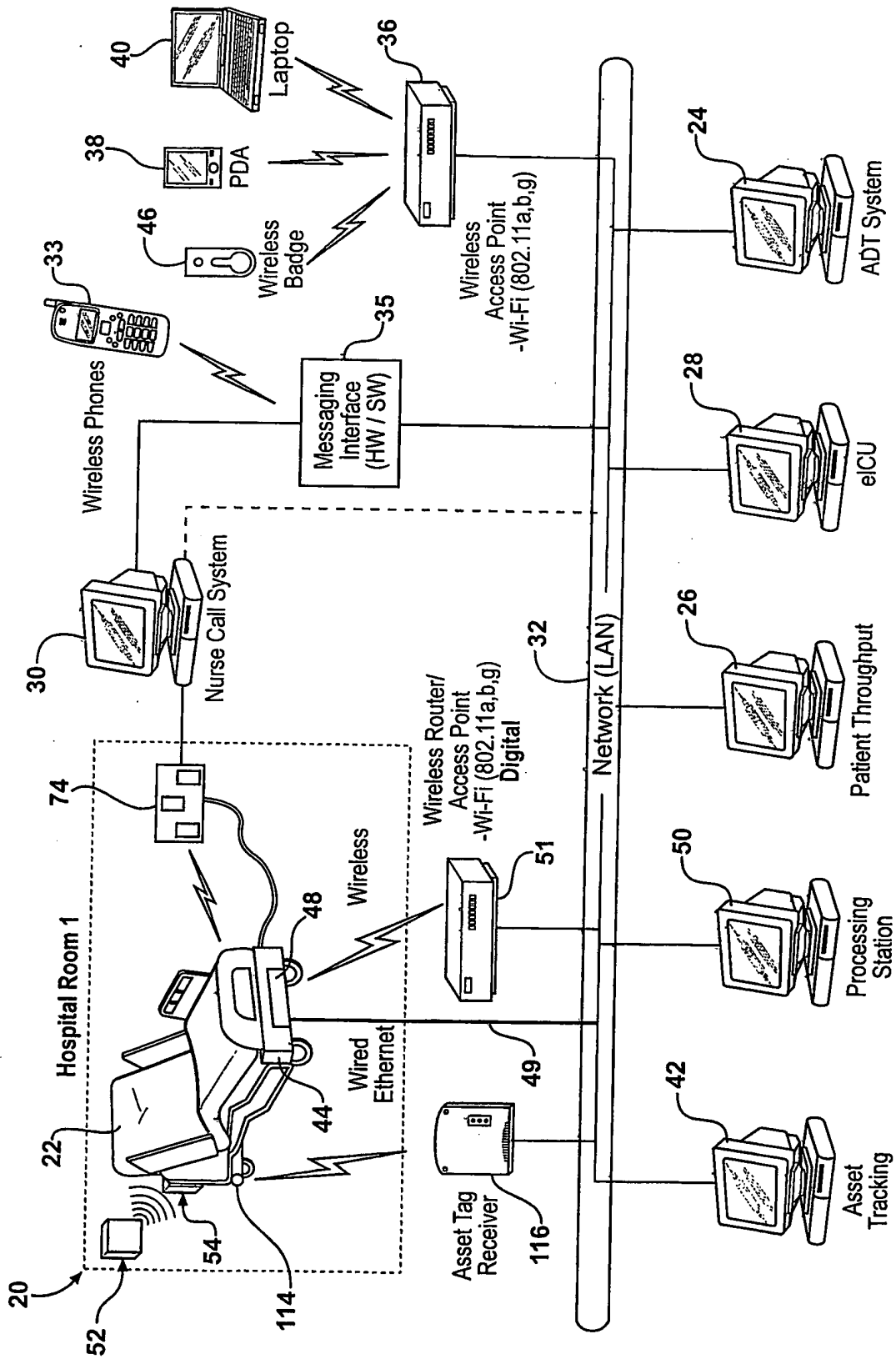

FIG - 1

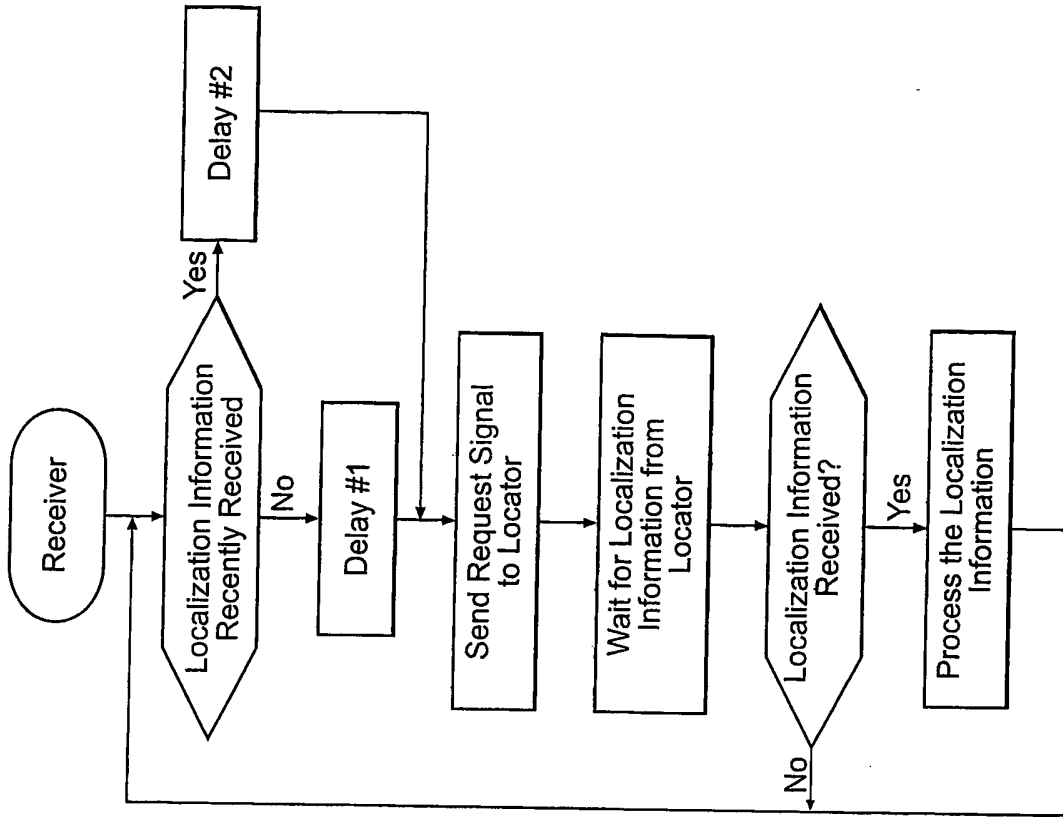

FIG - 6

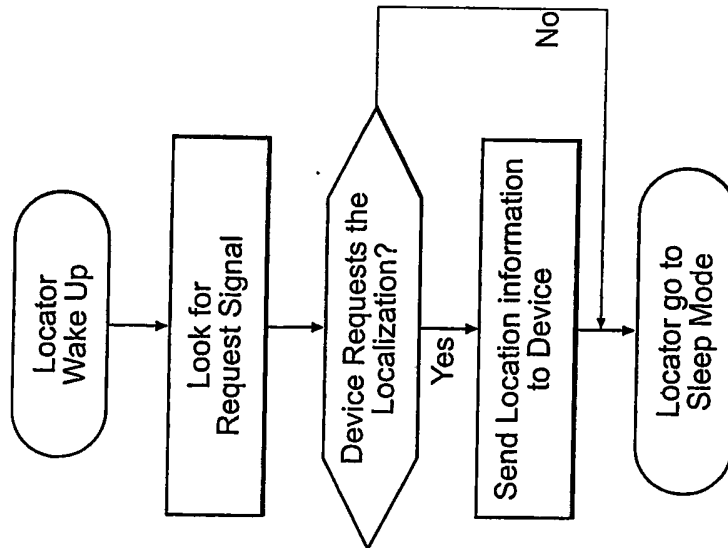

FIG - 5

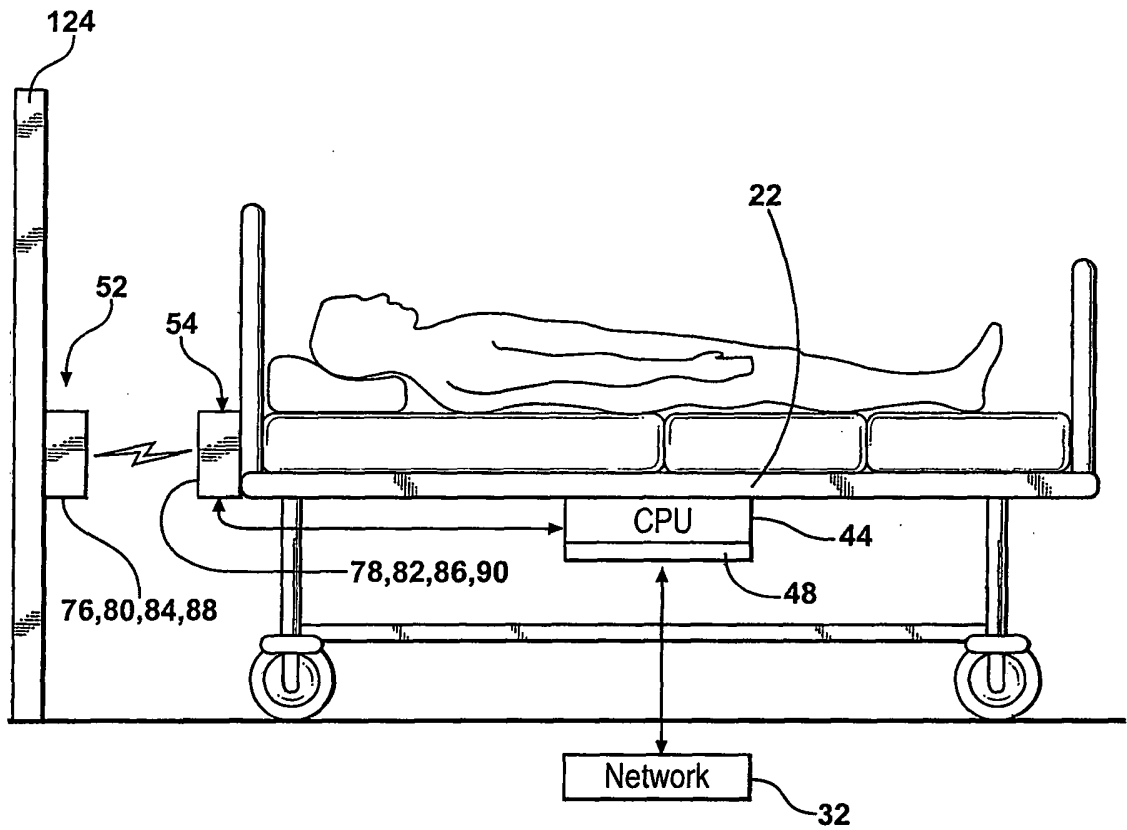

FIG - 7

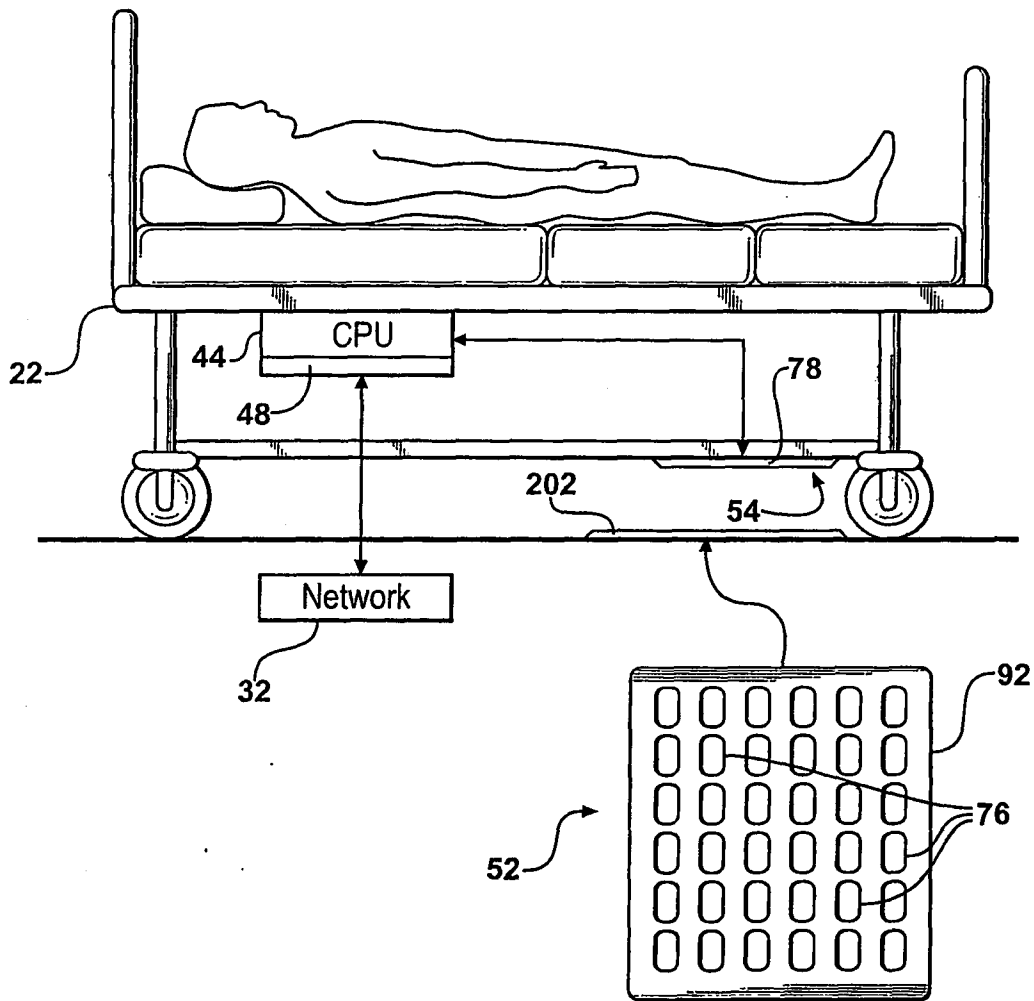
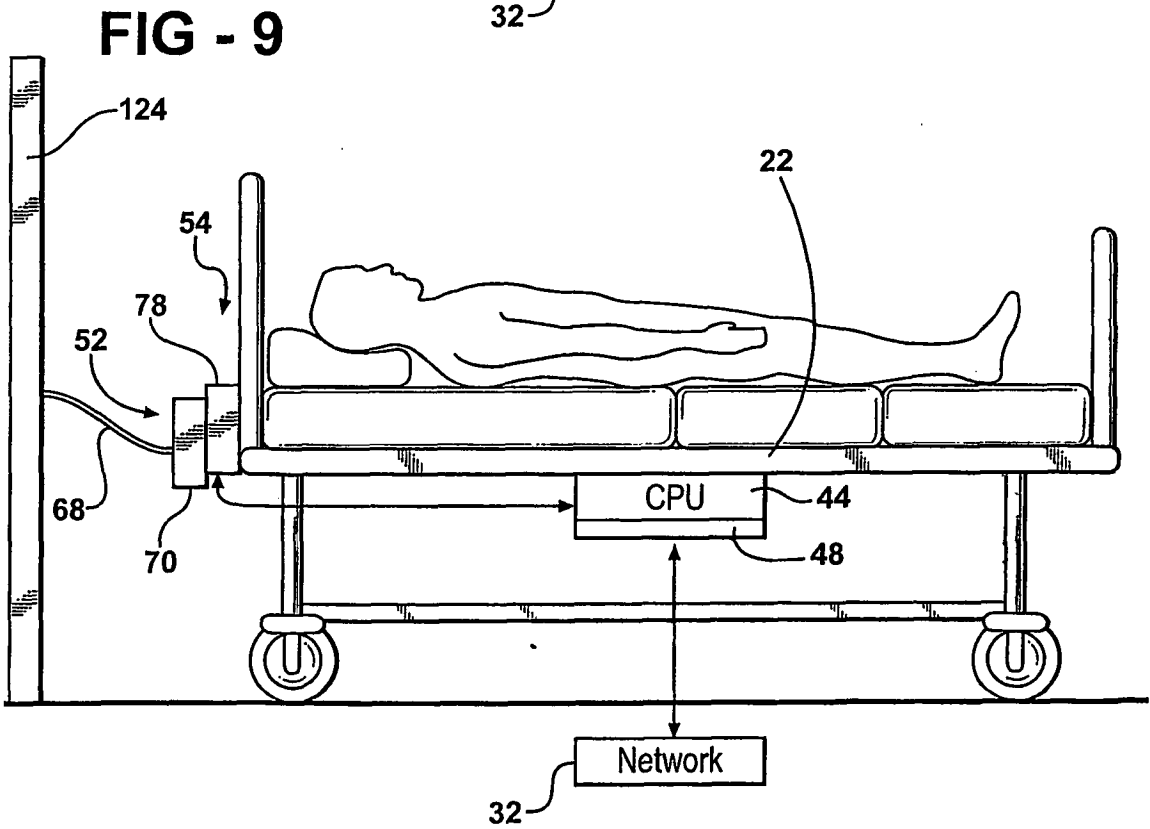
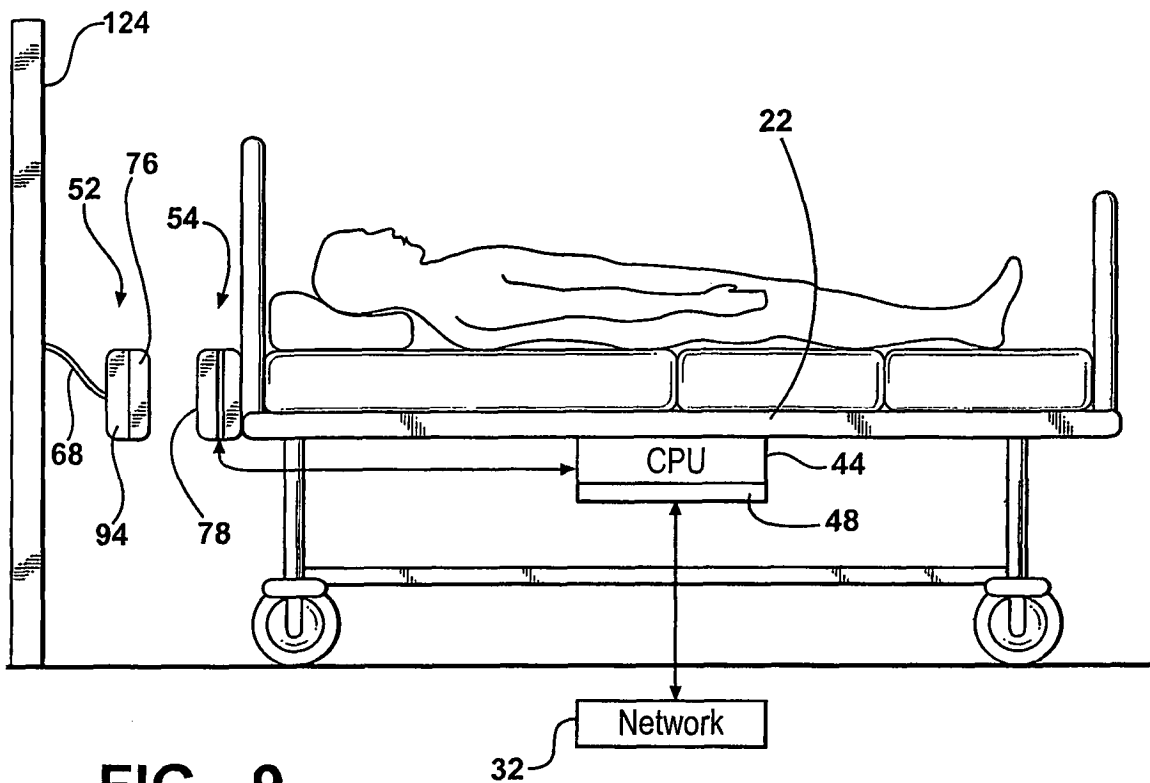

FIG - 8



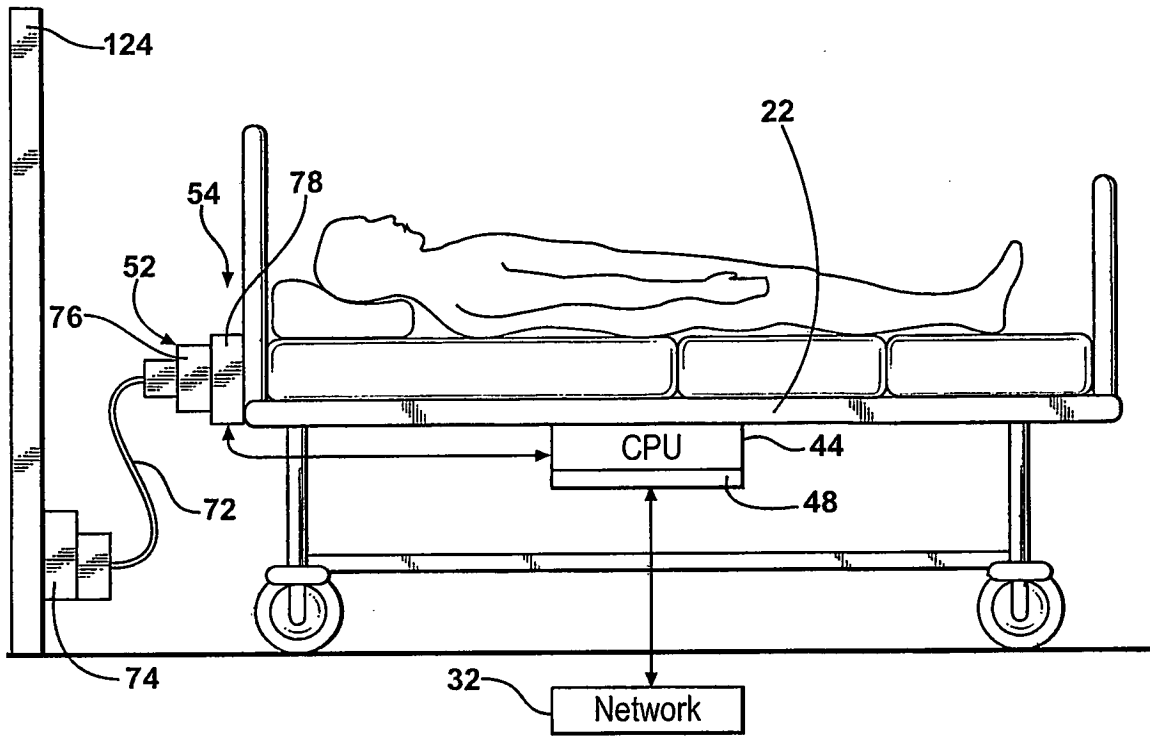

FIG - 11

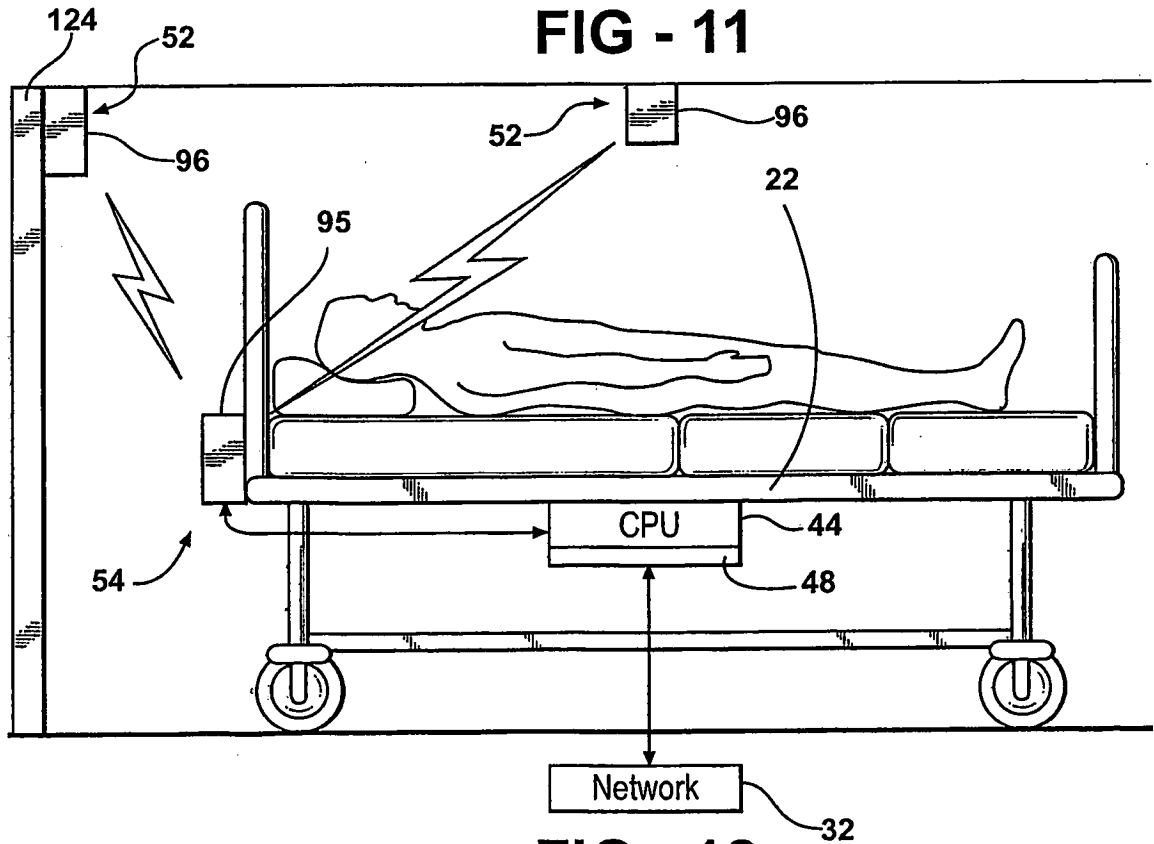

FIG - 12

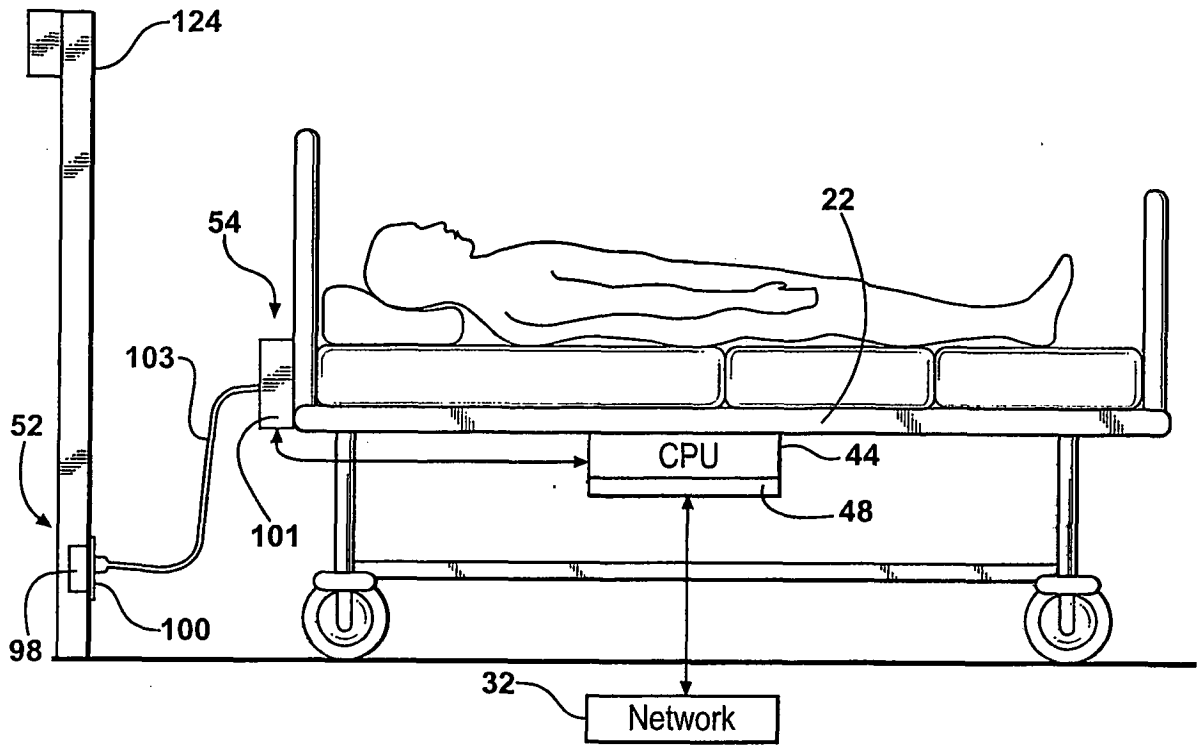

FIG - 13

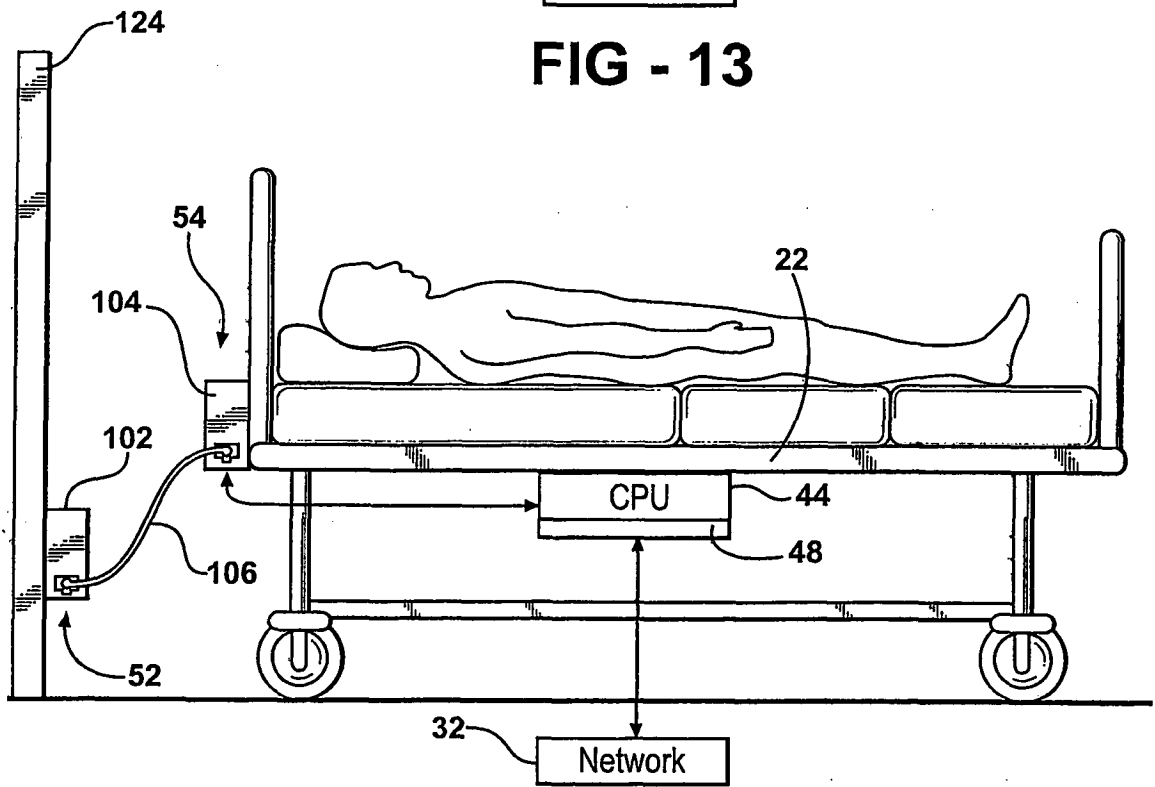

FIG - 14

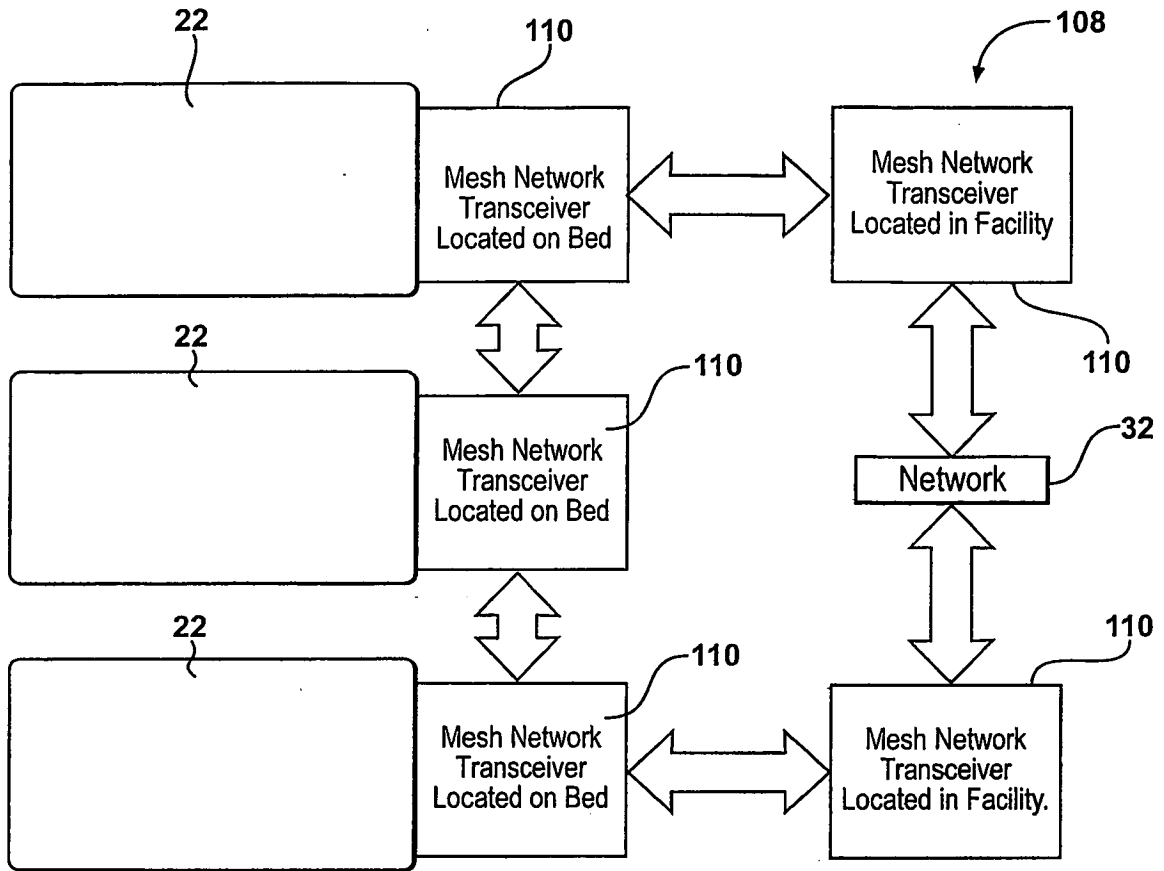

FIG - 15

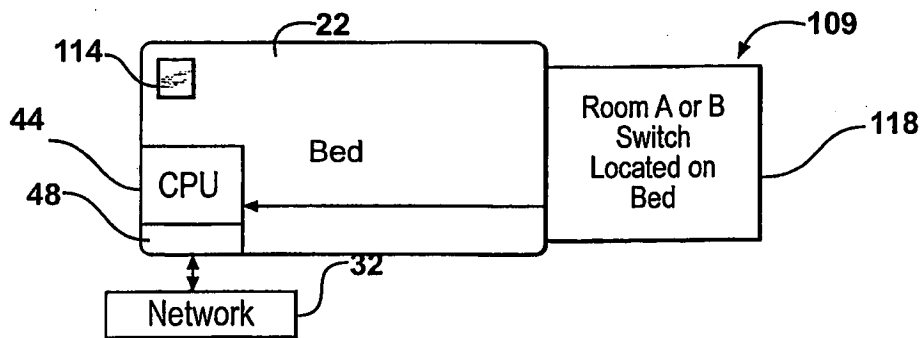
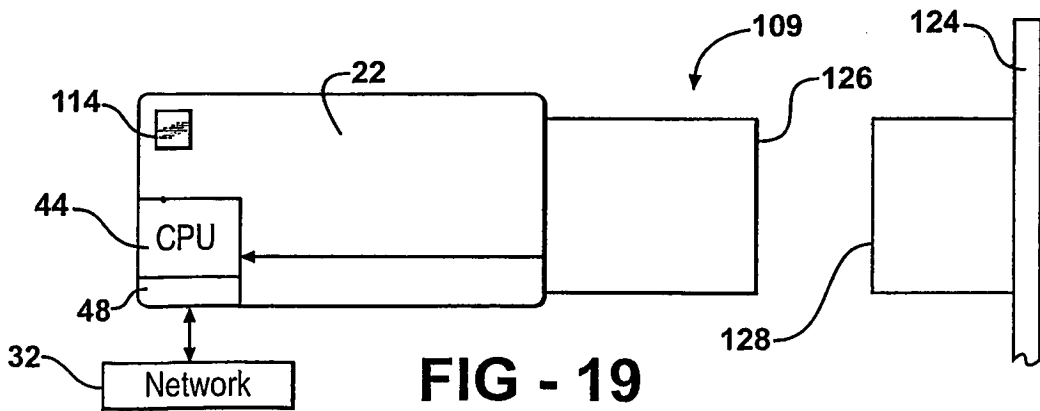
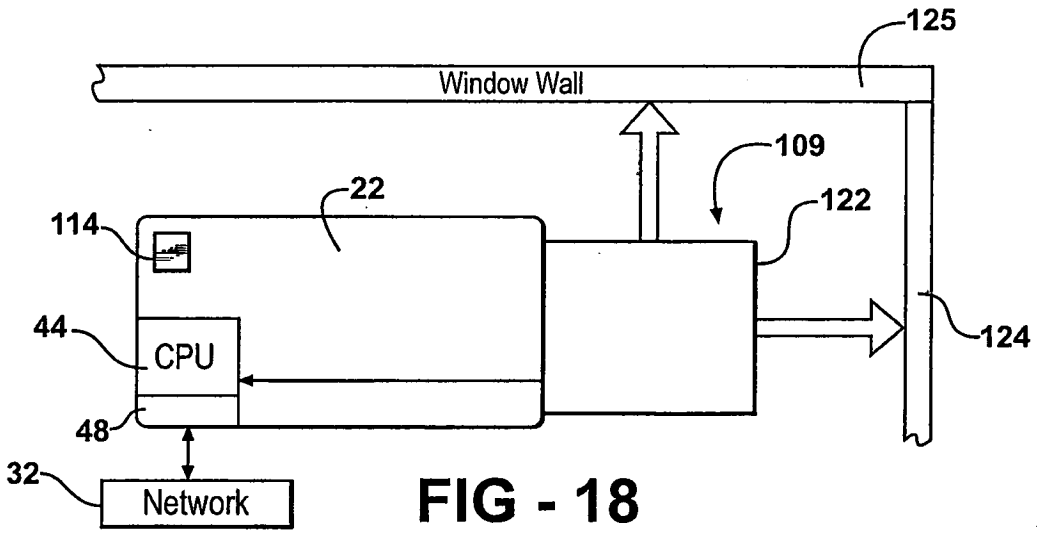
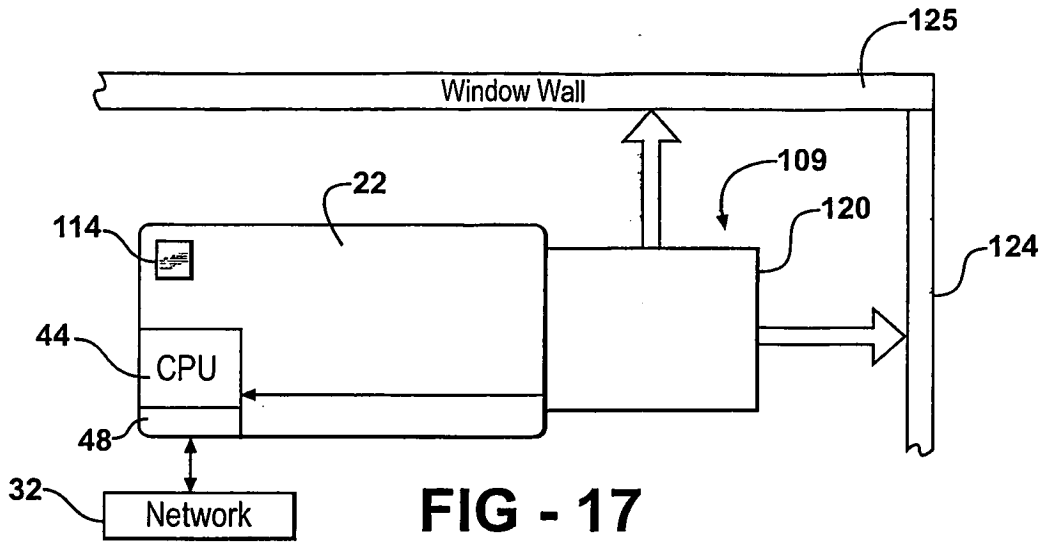

FIG - 16



REFERENCES CITED IN THE DESCRIPTION

This list of references cited by the applicant is for the reader's convenience only. It does not form part of the European patent document. Even though great care has been taken in compiling the references, errors or omissions cannot be excluded and the EPO disclaims all liability in this regard.

Patent documents cited in the description

- US 20040106854 A [0005]

专利名称(译)	用于患者处理装置的位置检测系统		
公开(公告)号	EP1865833B1	公开(公告)日	2011-08-10
申请号	EP2006748910	申请日	2006-03-29
[标]申请(专利权)人(译)	史赛克加拿大管理有限公司		
申请(专利权)人(译)	STRYKER加拿大管理公司.		
当前申请(专利权)人(译)	STRYKER加拿大管理公司.		
[标]发明人	BECKER DAVID TERRANCE MACDONALD BRUCE L MROZ JOSEPH E HAYES MICHAEL JOSEPH HOPPER CHRISTOPHER JOHN MAYORAS RICHARD C JR STRYKER MARTIN W SHANKAR VIVEK DIONNE JEAN PAUL		
发明人	BECKER, DAVID, TERRANCE MACDONALD, BRUCE, L. MROZ, JOSEPH, E. HAYES, MICHAEL, JOSEPH HOPPER, CHRISTOPHER, JOHN MAYORAS, RICHARD, C., JR. STRYKER, MARTIN, W. SHANKAR, VIVEK DIONNE, JEAN-PAUL		
IPC分类号	A61B5/00		
CPC分类号	A61B5/0002 A61B5/1113 A61B5/6889 A61B5/6891 G08B13/14 Y02A90/22 Y02A90/26 G08B1/08 G08B3/14		
优先权	60/665955 2005-03-29 US 60/734083 2005-11-07 US		
其他公开文献	EP1865833A1 EP1865833B2		
外部链接	Espacenet		

摘要(译)

提供位置检测系统用于确定医疗机构中的患者处理装置 (22) 的位置。在一个实施例中，位置检测系统 (20) 包括固定在设施中每个房间 (房间1) 的每个区域 (A , B) 中的定位器 (52)。定位器 (52) 包括至少一个红外发射器 (56)，用于将唯一的位置标识符发送到安装在患者处理设备 (22) 上的接收器 (54)。通信模块 (48) 将唯一位置标识符从患者处理设备 (22) 发送到医疗保健机构用于管理患者，人员和设备信息的网络 (32)。位于网络 (32) 上的处理站 (50) 处理唯一位置标识符以最终确定患者处理设备 (22) 的房间和区域位置。处理站 (50) 可以包括触摸屏显示器上的图形用户界面，用于查看和操纵位置信息。

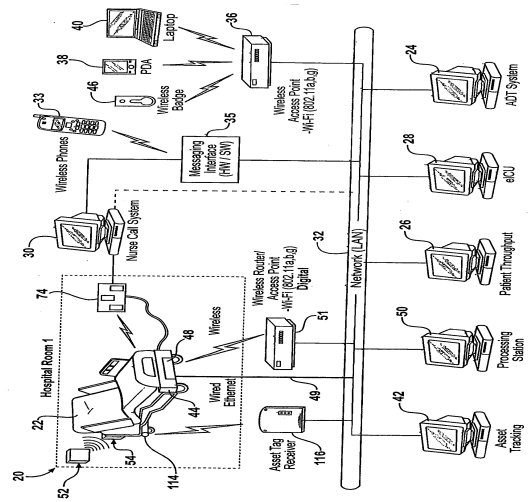

FIG - 1