

(19)



(11)

EP 1 692 501 B1

(12)

EUROPEAN PATENT SPECIFICATION

(45) Date of publication and mention of the grant of the patent:
06.01.2016 Bulletin 2016/01

(51) Int Cl.:
G01N 33/48 (2006.01) A61B 10/00 (2006.01)
B01L 3/00 (2006.01) G01N 33/487 (2006.01)

(21) Application number: **04819164.7**

(86) International application number:
PCT/US2004/038425

(22) Date of filing: **15.11.2004**

(87) International publication number:
WO 2005/050165 (02.06.2005 Gazette 2005/22)

(54) RAPID SAMPLE ANALYSIS AND STORAGE DEVICES AND METHODS OF USE

SCHNELLE PROBENANALYSE SOWIE AUFBEWAHRUNGSVORRICHTUNGEN UND VERWENDUNGSVERFAHREN

DISPOSITIFS DE STOCKAGE ET D'ANALYSE RAPIDES D'ECHANTILLON ET LEURS METHODES D'UTILISATION

(84) Designated Contracting States:
AT BE BG CH CY CZ DE DK EE ES FI FR GB GR HU IE IS IT LI LU MC NL PL PT RO SE SI SK TR

- **WU, Yuzhang**
Hangzhou 310023 (CN)
- **DAI, Jielin**
Hangzhou 310023 (CN)
- **YANG, Ying**
Hangzhou 310023 (CN)

(30) Priority: **14.11.2003 US 520437 P**

(43) Date of publication of application:
23.08.2006 Bulletin 2006/34

(74) Representative: **Lee, Nicholas John et al**
Kilburn & Strode LLP
20 Red Lion Street
London WC1R 4PJ (GB)

(73) Proprietor: **Alere Switzerland GmbH**
6300 Zug (CH)

(72) Inventors:
• **TUNG, Hsiaoho, Edward**
San Diego,
CA 92130 (US)

(56) References cited:
WO-A2-00/72012 US-A- 4 580 577
US-A- 5 965 453

EP 1 692 501 B1

Note: Within nine months of the publication of the mention of the grant of the European patent in the European Patent Bulletin, any person may give notice to the European Patent Office of opposition to that patent, in accordance with the Implementing Regulations. Notice of opposition shall not be deemed to have been filed until the opposition fee has been paid. (Art. 99(1) European Patent Convention).

Description**Field of the Invention**

5 [0001] The present invention is directed to devices for the collection and rapid analysis of fluids for analytes of interest.

Background of the Invention

10 [0002] The following Background of the Invention is intended to aid the reader in understanding the invention and is not admitted to be prior art.

[0003] Illicit drug use is an established and growing problem in our society. In 2003, the US Department of Health and Human Services found that an estimated 19.5 million Americans or 8.2 percent of the population aged 12 or older, were current illicit drug users. Current illicit drug use means use of an illicit drug during the month prior to the US Department of Health and Human Services survey interview. Marijuana was found to be the most commonly used illicit drug, with a rate of 6.2 percent (14.6 million). An estimated 2.3 million persons (1.0 percent) were current cocaine users, 604,000 of whom used crack. Hallucinogens were used by 1.0 million persons, and there were an estimated 119,000 current heroin users.

[0004] To combat and monitor this problem, drug testing has become standard procedure in a variety of settings, such as employment, school, sports, law enforcement, and the like. To facilitate this effort, a drug-testing industry has emerged. This industry provides a variety of drug testing products. A typical product is a urine collection cup incorporating analysis tests. These devices can be complicated and difficult or messy to use, or they may pose special problems of sample adulteration by the subject trying to hide their recent drug abuse. In addition, urine samples cannot be collected in certain situations, such as on the road side or in public.

[0005] There is therefore a need for better methods and apparatuses for performing sample collection and testing.

Summary of the Invention

[0006] The present invention provides test devices for detecting an analyte suspected of being present in a liquid sample. The devices contain a reservoir compartment, a test compartment, and a port for a sample collection well. The devices also have a rotatable sample collection well located in the port, a chamber for insertion of a sample applicator, an expression plate for wringing out the sample applicator and applying sample to the device, and an aliquot outlet and a reservoir outlet in the sample collection well for directing movement of sample through the device by rotating the sample collection well. The device also contains test elements for detecting the analyte of interest. By rotating the sample collection well, the operator is able to direct distribution of collected sample in the device by opening and/or closing outlets of the device. Methods of using the devices and kits containing the devices are also provided.

[0007] One aspect of the present invention is a test device for detecting an analyte suspected of being present in a liquid sample, comprising a reservoir compartment, a test compartment, and a port for a sample collection well, a rotatable sample collection well, situated in the port, and comprising an upper chamber, an expression plate, a lower chamber, an aliquot outlet, and a reservoir outlet, at least one test element comprised in the test compartment, wherein the sample collection well has a first position where fluid communication is provided through the reservoir outlet between the sample collection well and the reservoir compartment, and the sample collection well has a second position where fluid communication is provided through the aliquot outlet between the sample collection well and the test element, wherein the sample collection well is rotatable between the first and second positions. In one embodiment when the sample collection well is in the first position the aliquot outlet is closed, and when the sample collection well is in the second position, the reservoir outlet is closed. In various embodiments, one or more of these components are contained within a casing.

[0008] The term "reservoir compartment" refers to a sealable area of the apparatus in which fluid sample is stored and preserved from drying out or from contamination. The fluid sample can be stored in the reservoir compartment for confirmatory testing at a later time. The term "fluid communication" refers to the ability for liquid to flow and be transmitted between two areas which are in fluid communication. Thus, the collection well and the reservoir compartment are in fluid communication when fluid is able to flow from the collection well directly through the reservoir outlet and into the reservoir compartment. "Port" refers to the portion of the device or casing where the sample collection well interfaces with the casing, and can be placed into fluid communication with the test compartment and reservoir compartment by rotation of the sample collection well. The sample collection well can be inserted into the port as a separate part, or the sample collection well and casing can be manufactured as a single part. The sample collection well itself can be made of one part, or assembled from sub-parts. The sample collection well may comprise a first part containing the upper chamber and the expression plate and a second part containing the lower chamber.

[0009] The "aliquot outlet" is an aperture in the sample collection well that provides fluid communication between the sample collection well and the test compartment when the aliquot outlet is open. The "reservoir outlet" is an aperture in

the sample collection well that provides fluid communication between the sample collection well and the reservoir compartment when the reservoir outlet is open. The aliquot outlet and reservoir outlets are both located in the sample collection well. In one embodiment both the aliquot and reservoir outlets are located in the lower compartment. The term "rotatable" refers to the ability of the sample collection well to be torsionally turned within the port. Rotation of the sample collection well results in the aliquot outlet or reservoir outlet being opened or closed.

[0010] In one embodiment the reservoir is in fluid communication with the lower chamber of the collection well through the reservoir outlet when the sample collection well is in the first position and the aliquot outlet is closed. In one embodiment, the test element is in fluid communication with the lower chamber of the collection well through the aliquot outlet when the sample collection well is in the second position, and the reservoir outlet is closed. The lower compartment can comprise an area between the bottom of the rotatable sample collection well and the expression plate. The aliquot outlet and the reservoir outlet can be situated on the bottom of the collection well. The sample collection well can also comprise an aliquot seal, for sealing of the aliquot reservoir when the rotatable sample collection well is located in the first position. But sealing of the aliquot outlet and reservoir outlet can also be accomplished by the rotation of the sample collection well, which can close off the reservoir outlet and open the aliquot outlet.

[0011] In certain embodiments, the lower compartment is an area between the expression plate and the bottom of the rotatable sample collection well. In further embodiments, the aliquot outlet and the reservoir outlet are situated on the bottom of the collection well. Additionally, in some embodiments when the rotatable sample collection well is located in the second position, the collection well has an aliquot seal for sealing of the aliquot reservoir. In further embodiments, the port has a guide slot, and the rotatable sample collection well has a guide pin extending from its outer surface and movably located within the guide slot, for directing rotation of the sample collection well from the first position to the second position. The guide slot can be substantially parallel to the longitudinal axis of the test element. The "guide slot" is a slot or opening in the device, casing, or part attached to the casing which allows insertion of a guide pin or other protrusion from the sample collection well. When the guide pin is inserted into the guide slot, the sample collection well can be rotated in the port to effect opening or closing of the reservoir and/or aliquot outlets.

[0012] An "expression plate" refers to a surface where a sample applicator filled with fluid sample can be squeezed or crushed against to express sample from the applicator. The expression plate can have openings or holes to allow the passage of fluid sample from the applicator to the sample collection well. The expression plate can be located within the sample collection well, but can also be placed in another location where expressed sample will flow to the collection well. In one embodiment the expression plate is located in the sample collection well and divides the upper and lower chambers, and has one or more holes or openings through which fluid sample can flow from the upper chamber to the lower chamber. When the sample collector is pressed against the expression plate, sample flows through the opening in the expression plate, into the lower chamber.

[0013] In additional embodiments, the device or casing can have a window for observation of the test element and for determining the results of an assay. The device or casing can also have a sealable reservoir orifice for extracting liquid sample from the reservoir. Thus, sample may be conveniently removed from the reservoir, through the reservoir orifice, without need to disassemble the device. The reservoir orifice can be conveniently located on the casing, and is thus separately accessible without need to rotate the collection cup or insert any implements through the collection cup to access the preserved sample in the reservoir.

[0014] The "test element" can be any element that performs a test. In one embodiment, the test element is a test strip. The test strip may contain a member of a specific binding pair on the test strip for conducting an immunoassay. The test strip may be a chemical test strip that provides a detectable color change or other detectable signal when the assay is complete. A variety of samples can be used with the present invention including, but not limited to, a bodily fluid or a sample derived from a biological tissue or a bodily fluid. For example, the sample may be saliva, blood, serum, plasma, urine, feces, spinal fluid, vaginal swabs, mucus, and tissue.

[0015] A variety of analytes can be tested for with the present invention. The analyte may be an infectious agent or indicative of an infected state. The analyte may be a drug (for example a drug of abuse), a hormone, a protein, a nucleic acid molecule, an etiological agent and a specific binding member. The term "drug of abuse" (DOA) refers to a drug that is taken for non-medical reasons (usually for mind-altering effects). The abuse of such drugs can lead to physical and mental damage and (with some substances) dependence, addiction and/or death. Examples of DOAs include cocaine; amphetamines (e.g., black beauties, white bennies, dextroamphetamines, dexies, beans); methamphetamines (crank, meth, crystal, speed); barbiturates (Valium®, Roche Pharmaceuticals, Nutley, New Jersey); sedatives (i.e. sleep-aids); lysergic acid diethylamide (LSD); depressants (downers, goofballs, barbs, blue devils, yellow jackets, ludes); tricyclic antidepressants (TCA, e.g., imipramine, amitriptyline and doxepin); phencyclidine (PCP); tetrahydrocannabinol (THC, pot, dope, hash, weed, etc.); and opiates (e.g., morphine, opium, codeine, heroin, oxycodone). Legal drugs that are taken for medical reasons, but on which overdose can easily occur may also be tested for using these test strips, for example, tricyclic antidepressants (imipramine and the like) and over the counter products containing acetaminophen.

[0016] In another aspect the present invention provides methods of detecting an analyte suspected of being present in a liquid sample. The methods involve applying a liquid sample suspected of containing the analyte to a sample

applicator; applying the liquid sample to a test device disclosed herein by wringing or squeezing the sample applicator into the test device, preferably the sample collection well, and detecting whether the analyte is present in the liquid sample.

5 [0017] In one embodiment the sample is applied to the sample applicator by placing the sample applicator into the mouth of the test subject, which may thus become filled with saliva. The liquid sample is applied to the test device by pressing or squeezing the sample applicator against the expression plate of the device, and wringing the sample applicator out so that liquid sample flows into the sample collection well. In one embodiment the sample flows into the bottom chamber of the sample collection well. After the reservoir is filled with saliva, the sample collection well may then be rotated from the first position to the second position to begin the assay.

10 [0018] In another aspect the present invention provides a test kit for detecting an analyte suspected of being present in a liquid sample. The test kit includes a device as described herein, and a sample applicator. The sample applicator can contain an absorbent portion, which may be made of a sponge or a foam. The sample applicator can be prepared by soaking in a solution designed to stimulate salivation in a test subject, thereby facilitating collection of saliva when placed into the mouth of a test subject. The kit can also include instructions for use of the device and sample applicator in the collection and determination of the presence of an analyte in saliva or oral fluid.

15 [0019] The summary of the invention described above is not limiting and other features and advantages of the invention will be apparent from the following detailed description, as well as from the claims.

Brief Description of the Drawings

20 [0020]

Figure 1 provides a perspective view of one embodiment of the present invention **100**.

Figure 2 provides an exploded view of the device of Figure 1.

Figure 3 provides another exploded view of the device of Figure 1.

25 Figure 4 show all six sides of the device of Figure 1.

Figure 5 provides an exterior view and a cut-away view of the device of Figure 1, illustrating the state of the device prior to use.

Figure 6 provides an exterior view and a cut-away view of the device of Figure 1, illustrating the state of the device during the expression of the sample **610** from the absorbent member **112**.

30 Figure 7 an exterior view and a cut-away view of the device of Figure 1, illustrating the state of the device after during release of the sample **610** into the test compartment and sealing of the reservoir **520**.

Figure 8 an exterior view and a cut-away view of the device of Figure 1, illustrating the state of the device after the device has been capped.

35 Detailed Description

[0021] In the following detailed description, reference is made to the accompanying drawings that form a part hereof, and in which is shown by way of illustration non-limiting specific embodiments in which the invention may be practiced. Other embodiments may be utilized and structural changes made without departing from the scope of the present invention, which is defined by the claims.

40 [0022] The present device has several advantages over the prior art. The devices and methods of the present invention enable the easy detection of analytes in fluid samples. The devices also allow a quantity of sample to be easily stored for confirmatory testing at a later time, using a different principle of testing if desired. The confirmation sample is therefore safely stored from contamination. The device also allows the user to control the time of beginning the assay, because the present invention allows the user to apply sample to the sample collection well and fill the reservoir compartment, but the assay will not begin until the user rotates the sample collection well and thereby opens the aliquot outlet. Figures 1-8 show only certain embodiments of the present invention for purposes of illustrating the invention, and are not limiting. With reference to the present disclosure the person of ordinary skill will realize other embodiments falling within the scope of the invention as defined by the claims.

50 [0023] With reference to Figure 1, an embodiment of the invention is shown having a casing **120** and a sample collection well **130**. A sample applicator **110** can also be supplied, having a rigid handle **114**, a rim **116** and an absorbent member **112**. In Figures 5 it is shown that the casing can have two regions, a test compartment **510** and a reservoir compartment **310**. With reference to Figure 3, these two regions of the casing are defined by the forms of the injection-molded top portion **260** and bottom portion **265** of the casing, and the reservoir bottom **274**. The different parts of the invention can conveniently be manufactured to snap together snugly. With reference to Figure 3, test elements **290** are located within the test compartment. The reservoir **310** holds an aliquot of sample that can be used for confirmation testing.

55 [0024] With reference to Figures 2 and 3, in this embodiment the sample collection well **130** is composed of a sleeve **220**, and an annular expresser **210** adapted to fit snugly therein, and a cuff **240**. The sample collection well **130** is

situated in a port 276 on the upper part 260 of the casing. The cuff 240 is integral to the upper part 260 of the casing, and has a guide slot 250 cut therein in parallel to the upper rim of the cuff. The sleeve 220 has a one guide pin 320 extending from its exterior surface 222 through the guide slot 250 of the cuff. Two or more guide slots 250 and guide pins 320 can be located on the cuff and sleeve. The sleeve and cuff are adapted so that the sleeve fits snugly within cuff and the sleeve can be rotated therein. The rotation of the sleeve within the cuff is guided by the guide slot 250 and the guide pin because the pin cannot move past the bounds of the slot 250.

[0025] With reference to Figure 5, a test compartment inlet 540 and a reservoir inlet 530 are located within the upper part 260 of the casing. The test compartment inlet 540 provides a passageway for fluid to flow into the test compartment from the sample collection well. The test compartment is not air-tight, and air displaced by in-flowing fluid can flow out through cracks between the upper and lower portions. The reservoir inlet 530 provides a passageway for fluid to flow into the reservoir. The reservoir can be air-tight, and can thus have air holes (not shown) for the displaced air to leave the reservoir inlet 530. In one embodiment the air holes are one or more small holes adjacent to the reservoir inlet 530 (for example a small hole on either side of the reservoir inlet). Thus, fluid flows into the reservoir while air escapes through the small holes.

[0026] The bottom 336 of the sample collection well has an aliquot outlet 330 and a reservoir outlet 332, for providing passage from the sample collection well to the test compartment and reservoir, respectively. In certain embodiments, the sleeve has first and second positions. The reservoir outlet 332 and aliquot outlet 330 are advantageously located on the bottom of the sample collection well so that when the sleeve is in the first position, the reservoir outlet is open, and therefore the reservoir is in fluid communication with the lower chamber of the sample collection well 130. When the sample collection well is in the first position, fluid expressed from the absorbent member 112 of the sample collector 110 flows through the expression plate 340, through the reservoir outlet 332, and into the reservoir 310. When the sample collection well is in the second position, fluid cannot flow into the test compartment because the aliquot outlet is not in fluid communication with expression plate.

[0027] Sample collection well 130 can be rotated to the second position (see Figures 5 - 7). When the sample collection well is in the second position, the aliquot outlet 330 is aligned with the test compartment inlet 540, and the test compartment is placed into fluid communication with the sample collection well. Once the sample collection well is in the second position, fluid expressed from the absorbent member 112 flows through the expression plate, through the aliquot outlet 330 and test compartment inlet 540, into the test compartment and onto the test strips.

[0028] The bottom 336 of the sample collection well can also have a reservoir seal 334, which is advantageously sized and placed so that when sample collection well is in the second position the reservoir seal seals the reservoir inlet 530, as well as any air holes adjacent to the reservoir inlet (which may be provided to allow air to escape as fluid sample enters the reservoir). In certain embodiments, an O-ring 230 is mounted on the aliquot outlet, reservoir outlet 322 and reservoir seal 334 (See Figure 3).

Sample Applicator

[0029] A sample applicator may be supplied with the device of the present invention. In one embodiment, the sample applicator has an absorbent member and a handle. The absorbent member is generally made of medical grade sponge or foam material commonly used in the art. But many other materials are available for use as an absorbent member, such as cotton or paper, or any material having suitable absorbent capacity. The handle is generally rigid, to facilitate manipulation of the absorbent member. The handle may be made of any material commonly employed in the art, such as plastic, wood, metal or cardboard. In one embodiment the handle has a rim 116 (Figure 1) to which the absorbent member is attached.

Test Strips

[0030] A variety of test strips can be incorporated into the present invention. Analyte test strips are provided in a variety of formats, such as immunoassay or chemical test format, for detecting analytes of interest in a sample, such as a drug of abuse or a metabolite suggestive of health status. In some formats, the test strips have a bibulous material having a sample application zone, a reagent zone and a test result zone. The sample is applied to the sample application zone and flows into the reagent zone by capillary action. In the reagent zone, the sample dissolves and mixes with reagents necessary for detection of the analyte (if it is present in the sample). The sample, now carrying the reagents, continues to flow to the test results zone. Additional reagents are immobilized in the test results zone. These reagents react with and bind the analyte (if present) or one of the first reagents from the reagent zone. In noncompetitive formats, a signal is produced if the sample contains the analyte, and no signal is produced if the analyte is not present. In competitive formats, a signal may be produced if no analyte is present, and no signal if analyte is present. The present invention is useful for all formats.

[0031] When the test element is a test strip, it may be made of bibulous or non-bibulous material. A test strip can

include more than one material, which are then in fluid communication. One material of a test strip may be overlaid on another material of the test strip, such as for example, filter paper overlaid on nitrocellulose. Alternatively or in addition, a test strip may include a region comprising one or more materials followed by a region comprising one or more different materials. In this case, the regions are in fluid communication and may or may not partially overlap one another. The material or materials of the test strip can be bound to a support or solid surface such as a supporting sheet of plastic, to increase its handling strength.

[0032] In embodiments where the analyte is detected by a signal producing system, such as by one or more enzymes that specifically react with the analyte, one or more components of the signal producing system can be bound to the analyte detection zone of the test strip material in the same manner as specific binding members are bound to the test strip material, as described above. Alternatively or in addition, components of the signal producing system that are included in the sample application zone, the reagent zone, or the analyte detection zone of the test strip, or that are included throughout the test strip, may be impregnated into one or more materials of the test strip. This can be achieved either by surface application of solutions of such components or by immersion of the one or more test strip materials into solutions of such components. Following one or more applications or one or more immersions, the test strip material is dried. Alternatively or in addition, components of the signal producing system that are included in the sample application zone, the reagent zone, or the analyte detection zone of the test strip, or that are included throughout the test strip, may be applied to the surface of one or more test strip materials of the test strip as was described for labeled reagents.

[0033] The zones can be arranged as follows: sample application zone, one or more reagent zones, one or more test results determination zones, one or more control zones, one or more adulteration zones, and fluid absorbing zone. If the test results determination zone includes a control zone, preferably it follows the analyte detection zone of the test result determination zone. All of these zones, or combinations thereof, can be provided in a single strip of a single material. Alternatively, the zones are made of different materials and are linked together in fluid communication. For example, the different zones can be in direct or indirect fluid communication. In this instance, the different zones can be jointed end-to-end to be in fluid communication, overlapped to be in fluid communication, or be communicated by another member, such a joining material, which is preferably bibulous such as filter paper, fiberglass or nitrocellulose. In using a joining material, a joining material may communicate fluid from end-to-end jointed zones or materials including such zones, end-to-end jointed zones or materials including such zones that are not in fluid communication, or join zones or materials that include such zones that are overlapped (such as but not limited to from top to bottom) but not in fluid communication.

[0034] When and if a test strip includes an adulteration control zone, the adulteration control zone can be placed before or after the results determination zone. When a control zone is present in the results determination zone on such a test strip, then the adulteration control zone is preferably before the control zone, but that need not be the case. In the embodiment of the present invention where a test strip is a control test strip for the determination of an adulteration analyte and/or a control, then the adulteration control zone can be placed before or after the control zone, but is preferably before the control zone.

[0035] Samples that can be tested with the device of the present invention include liquids of biological origin (e.g., casing fluids and clinical samples). Liquid samples may be derived from solid or semi-solid samples, including feces, biological tissue, and food samples. Such solid or semi-solid samples can be converted into a liquid sample by any suitable method, for example by mixing, chopping, macerating, incubating, dissolving or enzymatically digesting solid samples in a suitable liquid (e.g., water, phosphate-buffered saline, or other buffers). "Biological samples" include samples derived from living animals, plants, and food, including for example urine, saliva, blood and blood components, cerebrospinal fluid, vaginal swabs, semen, feces, sweat, exudates, tissue, organs, tumors, tissue and organ culture, cell cultures and conditioned media therefrom, whether from humans or animals. A preferred biological sample is urine. Food samples include samples from processed food components or final products, meat, cheese, wine, milk and drinking water. Plant samples include those derived from any plant, plant tissue, plant cell cultures and conditioned media therefrom. "Environmental samples" are those derived from the environment (e.g., a water sample from a lake or other casing of water, effluent samples, soil samples, ground water, ocean water, and runoff water. Sewage and related wastes can also be included as environmental samples.

[0036] Any analyte can be tested for utilizing the present invention and a suitable test element. In particular, the present invention can be utilized for the detection of a drug of abuse in saliva.

[0037] For example, analytes that can be tested using the present invention include but are not limited to creatinine, bilirubin, nitrite, protein (nonspecific), hormones (e.g. human chorionic gonadotropin, luteinizing hormone, follicle stimulating hormone, etc.), blood, leukocytes, sugar, heavy metals or toxins, bacterial components (e.g. proteins or sugars specific to a particular type of bacteria, such as *E. coli*0157:H7, *S. aureus*, *Salmonella*, *C. perfringens*, *Campylobacter*, *L. monocytogenes*, *V. parahaemolyticus*, or *B.cereus*) and physical characteristics of the urine sample, such as pH and specific gravity. Any other clinical urine chemistry analyte that can be adapted to a lateral flow test format may also be incorporated into the present device.

Methods of Use

[0038] The invention also provides methods of detecting the presence of an analyte in a fluid sample, using the device described herein. Figures 5 through 8 illustrate some of the steps of these methods. Figure 5 illustrates one embodiment, wherein the absorbent member of the sample applicator has been saturated with sample by placing in the mouth of a test subject. The sample applicator is shown about to be inserted into the sample collection well **130**. Note in the exterior view that the sample collection well is in the first position, shown by the location of the guide pin on the side of the guide slot (denoted by 1st). In the section view, it can be seen that when the sample collection well is in the first position, the reservoir outlet and the reservoir inlet are aligned, forming a passage for fluid communication between the lower chamber **520** of the sample collection well and the reservoir. Additionally, the test compartment inlet and the test compartment are closed.

[0039] Figure 6 illustrates another embodiment, wherein the sample applicator has been inserted into the sample collection well and against the expression plate. The sample applicator is pressed downward against the expression plate **340**, thereby wringing or squeezing the absorbent member of the sample applicator, causing fluid **610** contained within the absorbent member to be expressed into the sample collection well. Fluid passing through the expression plate is denoted by downward-pointing arrows. Expressed fluid is denoted by grey shading. Optionally, the expression plate may have two or more vertical ribs **570** under which the rim of the sample applicator may be twisted, to ensure sufficient compression of the absorbent member. The expressed fluid passes through the holes or orifices in the expression plate to the bottom of the sample collection well. As discussed, when the sample collection well is in the first position, the reservoir outlet is aligned with the reservoir inlet. In this embodiment, the aliquot outlet is closed when the collection well is in the first position. Thus, the fluid in the bottom of the sample collection well flows through aligned reservoir outlet and reservoir inlet. Air within the reservoir being displaced by incoming fluid escapes into the bottom of the sample collection well through holes in the bottom plane of the sample collection well adjacent to the reservoir inlet.

[0040] In Figure 7, the sample collection well has been rotated to the second position. In the exterior view, it can be seen that the guide pin has moved to the end to the guide slot denoted 2nd. When the guide pin is at the 2nd position in the guide slot, the reservoir outlet is closed and the reservoir inlet sealed by the reservoir seal **334** (Fig. 3). Additionally, the aliquot outlet **330** and the test compartment inlet **540** are in alignment and mated, so that the test elements **290** are in fluid communication with the lower chamber of the sample collection well. Thus, fluid remaining in the lower chamber of the sample collection well flows into the test compartment and contacts the test strips. When the sample fluid comes into contact with the test strips, the fluid is absorbed by the test strips and the assay begins. Assay times will vary depending on the sample consistency and the test element used.

[0041] Figure 8 illustrates another (and optional) step of using the device of the present invention, capping the device. As shown in Figure 8, the sample collection well is left in the 2nd position. Cap **280** is placed on top of the sample collection well. The reservoir is still sealed. The device may now be shipped to another location for confirmation testing. For confirmation testing, the orifice seal **272** can be removed or broken and an aliquot of sample removed from the reservoir via the orifice **270**.

[0042] The test kits of the invention are provided with a sample applicator. In certain embodiments, instructions for using the device to detect the presence of an analyte in saliva or oral fluid, or other types of fluid, are also provided in the kit. The package format is variable, depending upon the customer's needs. For example, a facility that conducts large numbers of pre-employment drug screenings may prefer boxes of 1 set of instructions plus 20 vacuum packed set of devices and applicators, whereas other facilities may prefer boxed kits that contain only one device, one sample collector and one set of instructions.

ExamplesExample 1 - Analytical Sensitivity

[0043] This example illustrates the analytical sensitivity of the devices and methods of the invention. Ten devices were tested with each sample solution, for a total of 300 tests. The devices were tested with normal saliva, and using test strips that had the antigen affixed thereto for the drugs of abuse being tested for. The test strips functioned in a competitive format, with multiple gold sol-labeled antibodies present in a label zone, and antigens present on the test line.

[0044] The devices were also tested with PBS spiked with a standard solution of Cocaine (COC), Methamphetamine (MAMP), Phencyclidine (PCP), tetrahydrocannabinol (THC), morphine (MOP) or amphetamine (AMP) at concentrations of 0x, 0.5x, 1.5x and 3x times the detection limit. For example, the detection limit of the saliva THC test is 4 ng/ml. So PBS containing 0ng/ml, 2 ng/ml, 6 ng/ml and 8 ng/ml of THC were tested. For convenience, the amounts of drugs tested are shown in the table below.

EP 1 692 501 B1

| Drug (Detection Limit) | Saliva | PBS | PBS + 0.5X Drug | PBS + 1.5X Drug | PBS+3X Drug |
|------------------------|---------|---------|-----------------|-----------------|-------------|
| COC (20 ng/ml) | 0 ng/ml | 0 ng/ml | 10 ng/ml | 30 ng/ml | 60 ng/ml |
| MAMP (50 ng/ml) | 0 ng/ml | 0 ng/ml | 25 ng/ml | 75 ng/ml | 150 ng/ml |
| PCP (10 ng/ml) | 0 ng/ml | 0 ng/ml | 5 ng/ml | 15 ng/ml | 30 ng/ml |
| THC (4 ng/ml) | 0 ng/ml | 0 ng/ml | 2 ng/ml | 6 ng/ml | 12 ng/ml |
| MOP (40 ng/ml) | 0 ng/ml | 0 ng/ml | 20 ng/ml | 60 ng/ml | 120 ng/ml |
| AMP (50 ng/ml) | 0 ng/ml | 0 ng/ml | 25 ng/ml | 75 ng/ml | 150 ng/ml |

[0045] To perform each test, saliva, PBS or spiked PBS, as described above, was absorbed into the absorbent sponge of the sample applicator and then expressed into the sample collection well of the test device. Next, the sample well was rotated from the first position to the second position. After the sample well was rotated to the second position, the test strips were observed to become wet and the fluid to wick through the test strips. The test results were recorded at ten minutes and are shown in the table below.

| Drug | Saliva | PBS | PBS + 0.5X Drug | PBS + 1.5X Drug | PBS + 3X Drug | % Correct Result |
|------|----------|----------|-----------------|-----------------|------------------|------------------|
| COC | negative | negative | weak neg. | positive | very strong pos. | 100% |
| MAMP | negative | negative | weak neg. | positive | very strong pos | 100% |
| PCP | negative | negative | weak neg. | positive | very strong pos | 96% |
| THC | negative | negative | weak neg. | positive | very strong pos | 100% |
| MOP | negative | negative | weak neg. | positive | very strong pos | 100% |
| AMP | negative | negative | weak neg. | positive | very strong pos | 100% |

[0046] Test results demonstrated that the device of the present invention is very sensitive and provided the expected cutoff ranges.

Example 2 - Sample Size Variability

[0047] This example illustrates the effect of sample size on the performance of the present device. Replicates of five devices were tested with the same drugs tested in Example 1, at 0X, 0.5X and 3X concentrations (made in PBS as described above). Sample volumes of 100 ul, 150 ul, 200 ul and 250 ul were pipetted into the devices, instead of applying the sample with the sample applicator. All results were read as positive (pos) or negative (neg) at 10 minutes after sample application. With the exception of the 0.5X THC test at 250 ul (which provided 4 out of 5 identical results), all five replicates in each test group gave identical results. Therefore, the devices are able to provide a correct result even with considerable variability in sample volume.

Example 3 - Pre-Employment Drug Screening

[0048] The devices of the invention can be utilized in a variety of contexts, for example, for pre-employment drug screening. The person to be tested provides a sample of saliva by placing the sample applicator into his or her mouth, and allowing it to remain in the mouth for about 5 minutes. In embodiments for pre-employment drug screening the device contains test strips for several common drugs of abuse, in this embodiment cocaine, methamphetamine, phen-cyclidine, THC, morphine, and amphetamines. These test strips utilize a competitive immunoassay format where labeled specific binding molecules (antibodies in this embodiment) for each drug being tested are present on the label zone of the test strip. The test lines contain the antigen being tested for. If analyte is present in the sample it is bound by labeled specific binding molecules in the label zone, thereby preventing the labeled antibody from binding to the test line. Thus, no signal occurs on the test line when analyte is present. Conversely, when no antigen is present in the saliva, the labeled antibodies bind to the test line providing the signal on the test line.

[0049] After receiving the filled or soaked sample applicator, the testing technician inserts it into the sample collection well of the device. The technician presses the applicator down into the well and then twists it, to lock the rim of the applicator under a pair a flanges (provided in this embodiment). Saliva is thereby expressed from the absorbent foam

of the sample applicator and flows through holes in the expression plate and into the lower chamber of the sample collection well. Since the collection well is in the first position, sample also flows through the reservoir outlet and into the reservoir. When all of sample is loaded and the reservoir contains sufficient sample to conduct a confirmation assay, the sample collection well is then turned from the first position to the second position, thereby sealing the reservoir and opening the aliquot outlet. Sample then flows into the test strips. After a few minutes, the control indicia are provided, indicating that the assay is complete. A signal is provided at each of the test lines, indicating that no drugs of abuse are present in the saliva sample. If a positive result is determined, the device may be sent to a confirmatory laboratory so that the sample contained in the reservoir can be tested to confirm the result.

[0050] The invention illustratively described herein may be practiced in the absence of any element or elements, limitation or limitations that are not specifically disclosed herein. The terms and expressions which have been employed are used as terms of description and not of limitation, and there is no intention that in the use of such terms and expressions of excluding any equivalents of the features shown and described or portions thereof, but it is recognized that various modifications are possible within the scope of the invention claimed. Thus, it should be understood that although the present invention has been specifically disclosed by various embodiments and optional features, modification and variation of the concepts herein disclosed may be resorted to by those skilled in the art, and that the scope of this invention is limited only by the appended claims.

Claims

1. A test device for detecting an analyte suspected of being present in a liquid sample, comprising:

a reservoir compartment (310), a test compartment (510), and a port (276) for a sample collection well (130); a rotatable sample collection well (130), situated in the port (276) and comprising an upper chamber, an expression plate (340), a lower chamber (520), an aliquot outlet (330), and a reservoir outlet (332), at least one test element (290) comprised in the test compartment (510);

wherein

the sample collection well (130) has a first position where fluid communication is provided through the reservoir outlet (332) between the sample collection well (130) and the reservoir compartment (310); and

the sample collection well (130) has a second position where fluid communication is provided through the aliquot outlet (330) between the sample collection well (130) and the test element (290), wherein the sample collection well (130) is rotatable between the first and second positions.

2. The test device of claim 1, wherein the reservoir (310) is in fluid communication with the lower chamber of the collection well (130) through the reservoir outlet (332) when the sample collection well (130) is in the first position, and the aliquot outlet (330) is closed.

3. The test device of claim 1 or claim 2 wherein the test element (290) is in fluid communication with the lower chamber of the collection well (130) through the aliquot outlet (330) when the sample collection well is in the second position, and the reservoir outlet (332) is closed.

4. The device of claim 3 wherein the lower chamber (520) comprises an area between the bottom of the rotatable sample collection well (130) and the expression plate (340).

5. The device of claim 4 wherein the aliquot outlet (330) and the reservoir outlet (332) are situated on the bottom of the collection well (130).

6. The device of claim 5 wherein the collection well (130) further comprises an aliquot seal, for sealing of the aliquot reservoir when the rotatable sample collection well (130) is located in the first position.

7. The test device of claim 6 wherein the port (276) comprises a guide slot (250), and the rotatable sample collection well (130) comprises a guide pin (320) extending from its outer surface and movably located within the guide slot (250), for directing rotation of the sample collection well (130) from the first position to the second position.

8. The device of claim 7 wherein the guide slot (250) is substantially parallel to the longitudinal axis of the test element (290).

9. The test device of any preceding claim wherein the expression plate (340) comprises openings through which fluid

EP 1 692 501 B1

sample can flow from the upper chamber to the lower chamber (520).

5 10. The test device of any preceding claim further comprising a window for observation of the test element (290) and for determining the results of an assay.

11. The test device of any preceding claim further comprising a sealable reservoir orifice for extracting liquid sample from the reservoir (310).

10 12. The test device of any preceding claim wherein the test element (290) is a test strip.

13. The device of claim 12 wherein the test strip comprises specific binding molecules immobilized on the test strip.

14. The device of claim 12 or claim 13 wherein the test strip further comprises a chemical test.

15 15. The test device of any preceding claim wherein the sample is a bodily fluid or derived from a tissue or a bodily fluid.

16. The test device of any preceding claim wherein the sample is selected from the group consisting of saliva, blood, serum, plasma, urine, feces, spinal fluid, vaginal swabs, mucus, and tissue.

20 17. The test device of any preceding claim wherein the analyte is an infectious agent or indicative of an infected state.

18. The test device of any preceding claim wherein the analyte of interest is selected from the group consisting of: a drug, a drug of abuse, a hormone, a protein, a nucleic acid molecule, an etiological agent and a specific binding member.

25 19. The test device of any preceding claim wherein the sample collection well (130) is comprised of two or more parts, a first part containing the upper chamber and the expression plate (340), and a second part containing the lower chamber (520).

30 20. A method of detecting an analyte suspected of being present in a liquid sample, comprising applying a liquid sample suspected of containing the analyte to a sample applicator; applying the liquid sample to a test device as claimed in any preceding claim by wringing the sample applicator into the test device; and detecting whether the analyte is present in the liquid sample.

35 21. The method of claim 20 wherein sample is applied to the sample applicator by placing the sample applicator into the mouth of a test subject.

40 22. The method of claim 20 or claim 21 wherein the sample applicator is filled with saliva.

23. The method of claim 20, 21 or 22 wherein liquid sample is applied to the test device by pressing the sample applicator against the expression plate (340) of the device, and wringing the sample applicator out so that liquid sample flows into the bottom chamber of the sample collection well (130).

45 24. The method of any one of claims 20 to 23 further comprising rotating the rotatable sample collection (130) well into the second position.

25. A kit comprising:

50 a device as claimed in any one of claims 1 to 19;
and a sample applicator.

26. The kit of claim 25, wherein the sample applicator comprises an absorbent portion which comprises a foam.

55 27. The kit of claim 26, wherein the absorbent portion is treated with a solution that stimulates salivation in a test subject.

28. The kit of claim 25, 26 or 27 further comprising instructions for use of the device and sample applicator in the collection and determination of the presence of an analyte in saliva.

Patentansprüche

1. Testvorrichtung zum Erkennen eines Analyts, von dem angenommen wird, dass er in einer flüssigen Probe vorhanden ist, Folgendes enthaltend:

5 einen Behälterraum (310), einen Testraum (510), einen Anschlussstutzen (276) für einen Probensammelschacht (130),
einen drehbaren Probensammelschacht (130), der im Anschlussstutzen (276) untergebracht ist und eine obere Kammer, eine Expressionsplatte (340), eine untere Kammer (520), einen Aliquotauslass (330) und einen Behälterauslass (332) enthält,
10 mindestens ein Testelement (290), das im Testraum (510) enthalten ist,
wobei
der Probensammelschacht (130) eine erste Position aufweist, in der eine Fluidverbindung zwischen dem Probensammelschacht (130) und dem Behälterraum (310) durch den Behälterauslass (332) vorgesehen ist, und
15 der Probensammelschacht (130) eine zweite Position aufweist, in der eine Fluidverbindung zwischen dem Probensammelschacht (130) und dem Testelement (290) durch den Aliquotauslass (330) vorgesehen ist, wobei der Probensammelschacht (130) zwischen der ersten und der zweiten Position drehbar ist.
2. Testvorrichtung nach Anspruch 1, wobei der Behälter (310) durch den Behälterauslass (332) in Fluidverbindung mit der unteren Kammer des Sammelschachtes (130) steht, wenn sich der Probensammelschacht (130) in der ersten Position befindet und der Aliquotauslass (330) geschlossen ist.
3. Testvorrichtung nach Anspruch 1 oder 2, wobei das Testelement (290) durch den Aliquotauslass (330) in Fluidverbindung mit der unteren Kammer des Sammelschachtes (130) steht, wenn sich der Probensammelschacht in der zweiten Position befindet und der Behälterauslass (332) geschlossen ist.
4. Vorrichtung nach Anspruch 3, wobei die untere Kammer (520) zwischen dem Boden des drehbaren Probensammelschachts (130) und der Expressionsplatte (340) einen Bereich enthält.
5. Vorrichtung nach Anspruch 4, wobei der Aliquotauslass (330) und der Behälterauslass (332) am Boden des Sammelschachts (130) untergebracht sind.
6. Vorrichtung nach Anspruch 5, wobei der Sammelschacht (130) ferner eine Aliquotdichtung zum Abdichten des Aliquotbehälters aufweist, wenn der drehbare Probensammelschacht (130) in der ersten Position angeordnet ist.
7. Testvorrichtung nach Anspruch 6, wobei der Anschluss (276) einen Führungsschlitz (250) und der drehbare Probensammelschacht (130) einen Führungsstift (320) enthält, der sich aus dessen Außenfläche erstreckt und beweglich im Führungsschlitz (250) angeordnet ist, um die Drehung des Probensammelschachts (130) von der ersten Position in die zweite Position zu lenken.
8. Vorrichtung nach Anspruch 7, wobei der Führungsschlitz (250) im Wesentlichen parallel zur Längsachse des Testelements (290) liegt.
9. Testvorrichtung nach einem der vorhergehenden Ansprüche, wobei die Expressionsplatte (340) Öffnungen enthält, durch welche die Fluidprobe von der oberen Kammer in die untere Kammer (520) fließen kann.
10. Testvorrichtung nach einem der vorhergehenden Ansprüche, ferner ein Fenster zur Beobachtung des Testelements (290) und zum Bestimmen der Ergebnisse eines Assays enthaltend.
11. Testvorrichtung nach einem der vorhergehenden Ansprüche, ferner eine skalierbare Behältermündung zum Extrahieren einer flüssigen Probe aus dem Behälter (310) enthaltend.
12. Testvorrichtung nach einem der vorhergehenden Ansprüche, wobei das Testelement (290) ein Teststreifen ist.
13. Testvorrichtung nach Anspruch 12, wobei der Teststreifen spezielle Bindungsmoleküle enthält, die auf dem Teststreifen immobilisiert sind.
14. Vorrichtung nach Anspruch 12 oder 13, wobei der Teststreifen ferner einen chemischen Test enthält.

EP 1 692 501 B1

15. Testvorrichtung nach einem der vorhergehenden Ansprüche, wobei die Probe ein Körperfluid ist oder von einem Gewebe oder Körperfluid abgeleitet ist.
- 5 16. Testvorrichtung nach einem der vorhergehenden Ansprüche, wobei die Probe aus der Gruppe ausgewählt ist, die aus Speichel, Blut, Serum, Plasma, Urin, Kot, Rückenmarksflüssigkeit, Vaginalabstrich, Schleim und Gewebe besteht.
- 10 17. Testvorrichtung nach einem der vorhergehenden Ansprüche, wobei der Analyt ein Infektionserreger oder ein Indiz für einen Infektionszustand ist.
18. Testvorrichtung nach einem der vorhergehenden Ansprüche, wobei der Analyt von Interesse aus der Gruppe ausgewählt ist, die aus Folgendem besteht: einer Droge, einer missbräuchlich verwendeten Droge, einem Hormon, einem Protein, einem Nukleinsäuremolekül, einem Krankheitserreger und einem speziellen Bindeelement.
- 15 19. Testvorrichtung nach einem der vorhergehenden Ansprüche, wobei der Probensammelschacht (130) aus zwei oder mehr Teilen besteht, einem ersten Teil, der die obere Kammer und die Expressionsplatte (340) enthält, und einem zweiten Teil, der die untere Kammer (520) enthält.
- 20 20. Verfahren zum Erkennen eines Analyts, von dem angenommen wird, dass er in einer flüssigen Probe vorhanden ist, Folgendes enthaltend:
- Aufbringen einer flüssigen Probe, von der angenommen wird, dass sie den Analyten enthält, auf einen Probenapplikator,
Einbringen der flüssigen Probe in eine Testvorrichtung nach einem der vorhergehenden Ansprüche durch
25 Auspressen des Probenapplikators in die Testvorrichtung und
Erkennen, ob der Analyt in der flüssigen Probe vorhanden ist.
- 30 21. Verfahren nach Anspruch 20, wobei die Probe auf den Probenapplikator aufgebracht wird, indem der Probenapplikator im Mund einer Testperson platziert wird.
22. Verfahren nach Anspruch 20 oder 21, wobei der Probenapplikator mit Speichel gefüllt wird.
- 35 23. Verfahren nach Anspruch 20, 21 oder 22, wobei die flüssige Probe in die Testvorrichtung eingebracht wird, indem der Probenapplikator gegen die Expressionsplatte (340) der Vorrichtung gepresst und der Probenapplikator derart ausgepresst wird, dass die flüssige Probe in die untere Kammer des Probensammelschachts (130) fließt.
24. Verfahren nach einem der Ansprüche 20 bis 23, ferner das Drehen des drehbaren Probensammelschachts (130) in die zweite Position enthaltend.
- 40 25. Kit, Folgendes umfassend:
- eine Vorrichtung nach einem der Ansprüche 1 bis 19 und
einen Probenapplikator.
- 45 26. Kit nach Anspruch 25, wobei der Probenapplikator einen absorbierenden Abschnitt enthält, der einen Schaumstoff enthält.
27. Kit nach Anspruch 26, wobei der absorbierende Abschnitt mit einer Lösung behandelt ist, die den Speichelfluss einer Testperson anregt.
- 50 28. Kit nach Anspruch 25, 26 oder 27, ferner Anweisungen zur Verwendung der Vorrichtung und des Probenapplikators beim Auffangen und Bestimmen des Vorhandenseins eines Analyts im Speichel enthaltend.

55 **Revendications**

1. Dispositif de test pour détecter un analyte suspecté d'être présent dans un échantillon liquide, comprenant :

EP 1 692 501 B1

un compartiment de réservoir (310), un compartiment de test (510) et un orifice (276) pour un puits de collecte d'échantillon (130) ;

un puits de collecte d'échantillon rotatif (130), situé dans l'orifice (276) et comprenant une chambre supérieure, une plaque d'expression (340), une chambre inférieure (520), une sortie d'aliquote (330) et une sortie de réservoir (332),

au moins un élément de test (290) compris dans le compartiment de test (510) ;
dans lequel :

le puits de collecte d'échantillon (130) a une première position dans laquelle une communication fluide est établie à travers la sortie de réservoir (332) entre le puits de collecte d'échantillon (130) et le compartiment de réservoir (310) ; et

le puits de collecte d'échantillon (130) a une seconde position dans laquelle une communication fluide est établie à travers la sortie d'aliquote (330) entre le puits de collecte d'échantillon (130) et l'élément de test (290), le puits de collecte d'échantillon (130) étant apte à tourner entre les première et seconde positions.

2. Dispositif de test selon la revendication 1, dans lequel le réservoir (310) est en communication fluide avec la chambre inférieure du puits de collecte (130) à travers la sortie de réservoir (332) lorsque le puits de collecte d'échantillon (130) est dans la première position, et la sortie d'aliquote (330) est fermée.
3. Dispositif de test selon la revendication 1 ou 2, dans lequel l'élément de test (290) est en communication fluide avec la chambre inférieure du puits de collecte (130) à travers la sortie d'aliquote (330) lorsque le puits de collecte d'échantillon est dans la seconde position, et la sortie de réservoir (332) est fermée.
4. Dispositif selon la revendication 3, dans lequel la chambre inférieure (520) comprend une zone entre le fond du puits de collecte d'échantillon rotatif (130) et la plaque d'expression (340).
5. Dispositif selon la revendication 4, dans lequel la sortie d'aliquote (330) et la sortie de réservoir (332) sont situées sur le fond du puits de collecte (130).
6. Dispositif selon la revendication 5, dans lequel le puits de collecte (130) comprend en outre un joint d'étanchéité d'aliquote pour le scellement étanche du réservoir d'aliquote lorsque le puits de collecte d'échantillon rotatif (130) est placé dans la première position.
7. Dispositif de test selon la revendication 6, dans lequel l'orifice (276) comprend une fente de guidage (250), et le puits de collecte d'échantillon rotatif (130) comprend un ergot de guidage (320) s'étendant à partir de sa surface extérieure et placée de façon mobile à l'intérieur de la fente de guidage (250), pour diriger la rotation du puits de collecte d'échantillon (130) de la première position à la seconde position.
8. Dispositif selon la revendication 7, dans lequel la fente de guidage (250) est sensiblement parallèle à l'axe longitudinal de l'élément de test (290).
9. Dispositif de test selon l'une quelconque des revendications précédentes, dans lequel la plaque d'expression (340) comprend des ouvertures à travers lesquelles un échantillon fluide peut s'écouler de la chambre supérieure à la chambre inférieure (520).
10. Dispositif de test selon l'une quelconque des revendications précédentes, comprenant en outre une fenêtre pour l'observation de l'élément de test (290) et pour déterminer les résultats d'un essai.
11. Dispositif de test selon l'une quelconque des revendications précédentes, comprenant en outre un orifice de réservoir scellable de manière étanche, pour extraire de l'échantillon liquide à partir du réservoir (310).
12. Dispositif de test selon l'une quelconque des revendications précédentes, dans lequel l'élément de test (290) est un bâtonnet diagnostique.
13. Dispositif selon la revendication 12, dans lequel le bâtonnet diagnostique comprend des molécules de liaison spécifiques immobilisées sur le bâtonnet diagnostique.
14. Dispositif selon les revendications 12 ou 13, dans lequel le bâtonnet diagnostique comprend en outre un test

chimique.

5 15. Dispositif de test selon l'une quelconque des revendications précédentes, dans lequel l'échantillon est un fluide corporel ou est issu d'un tissu ou d'un fluide corporel.

16. Dispositif de test selon l'une quelconque des revendications précédentes, dans lequel l'échantillon est choisi dans le groupe constitué par la salive, le sang, le sérum, le plasma, l'urine, les fèces, le liquide rachidien, les frottis vaginaux, le mucus et le tissu.

10 17. Dispositif de test selon l'une quelconque des revendications précédentes, dans lequel l'analyte est un agent infectieux ou indiquant un état infecté.

18. Dispositif de test selon l'une quelconque des revendications précédentes, dans lequel l'analyte d'intérêt est choisi dans le groupe constitué par : un médicament, une drogue utilisée par les toxicomanes, une hormone, une protéine, 15 une molécule d'acide nucléique, un agent étiologique et un élément de liaison spécifique.

19. Dispositif de test selon l'une quelconque des revendications précédentes, dans lequel le puits de collecte d'échantillon (130) comprend deux parties ou plus, une première partie contenant la chambre supérieure et la plaque d'expression (340), et une seconde partie contenant la chambre inférieure (520). 20

20. Procédé de détection d'un analyte suspecté d'être présent dans un échantillon liquide, comprenant :

l'application d'un échantillon liquide suspecté de contenir l'analyte à un applicateur d'échantillon ;
l'application de l'échantillon liquide à un dispositif de test selon l'une quelconque des revendications précédentes par torsion de l'applicateur d'échantillon dans le dispositif de test ; et
25 la détection du point de savoir si l'analyte est présent dans l'échantillon liquide.

21. Procédé selon la revendication 20, dans lequel l'échantillon est appliqué à l'applicateur d'échantillon par mise en place de l'applicateur d'échantillon dans la bouche d'un sujet de test. 30

22. Procédé selon les revendications 20 ou 21, dans lequel l'applicateur d'échantillon est rempli de salive.

23. Procédé selon les revendications 20, 21 ou 22, dans lequel l'échantillon liquide est appliqué au dispositif de test par pression de l'applicateur d'échantillon contre la plaque d'expression (340) du dispositif et retrait de l'applicateur d'échantillon en le tordant de telle sorte que l'échantillon liquide s'écoule dans la chambre inférieure du puits de 35 collecte d'échantillon (130).

24. Procédé selon l'une quelconque des revendications 20 à 23, comprenant en outre la rotation du puits de collecte d'échantillon rotatif (130) dans la seconde position. 40

25. Kit comprenant :

un dispositif selon l'une quelconque des revendications 1 à 19 ;
45 et un applicateur d'échantillon.

26. Kit selon la revendication 25, dans lequel l'applicateur d'échantillon comprend une partie absorbante qui comprend une mousse.

27. Kit selon la revendication 26, dans lequel la partie absorbante est traitée avec une solution qui stimule la salivation chez un sujet de test. 50

28. Kit selon les revendications 25, 26 ou 27, comprenant en outre des instructions pour l'utilisation du dispositif et de l'applicateur d'échantillon pour la collecte et la détermination de la présence d'un analyte dans de la salive. 55

Figure 1

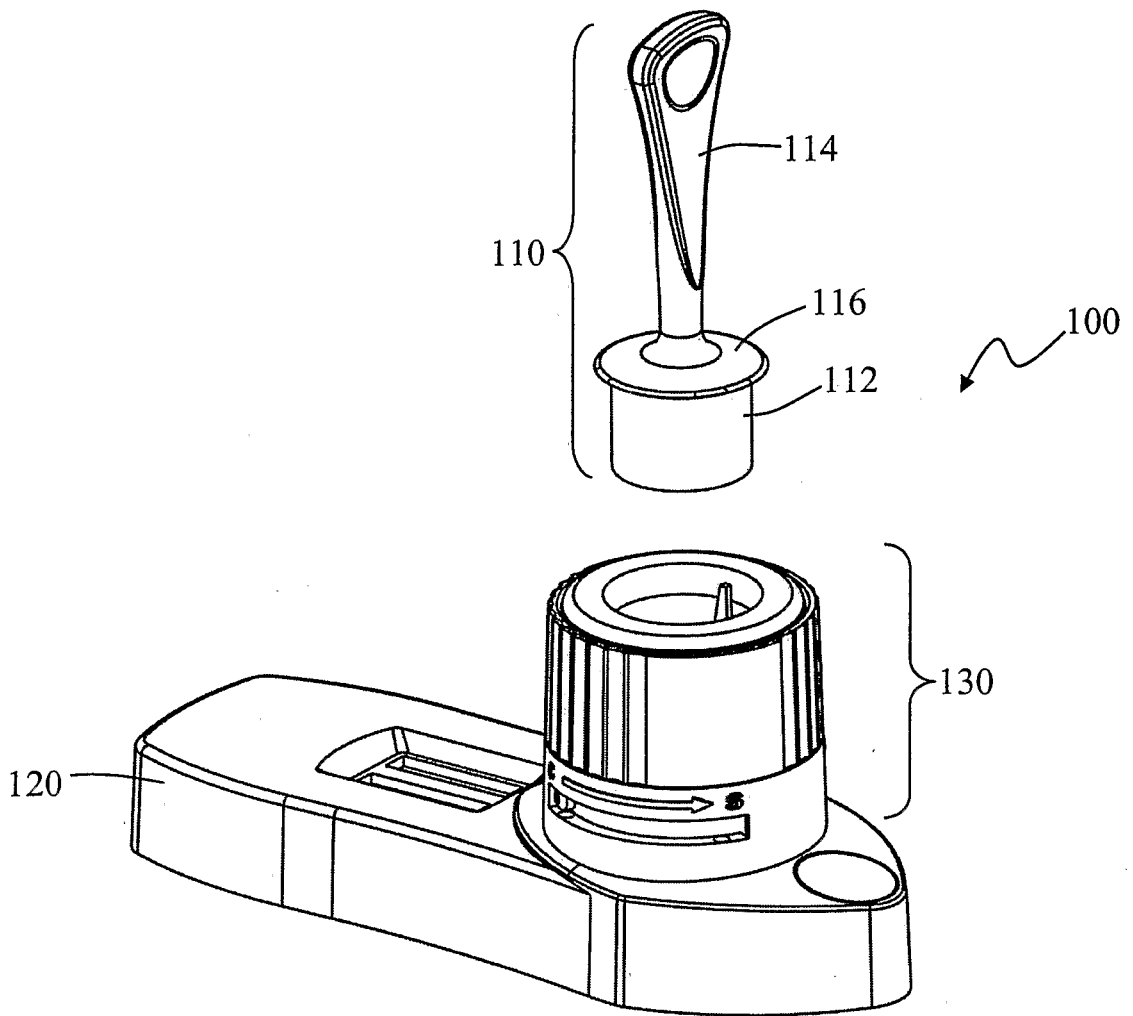

Figure 2

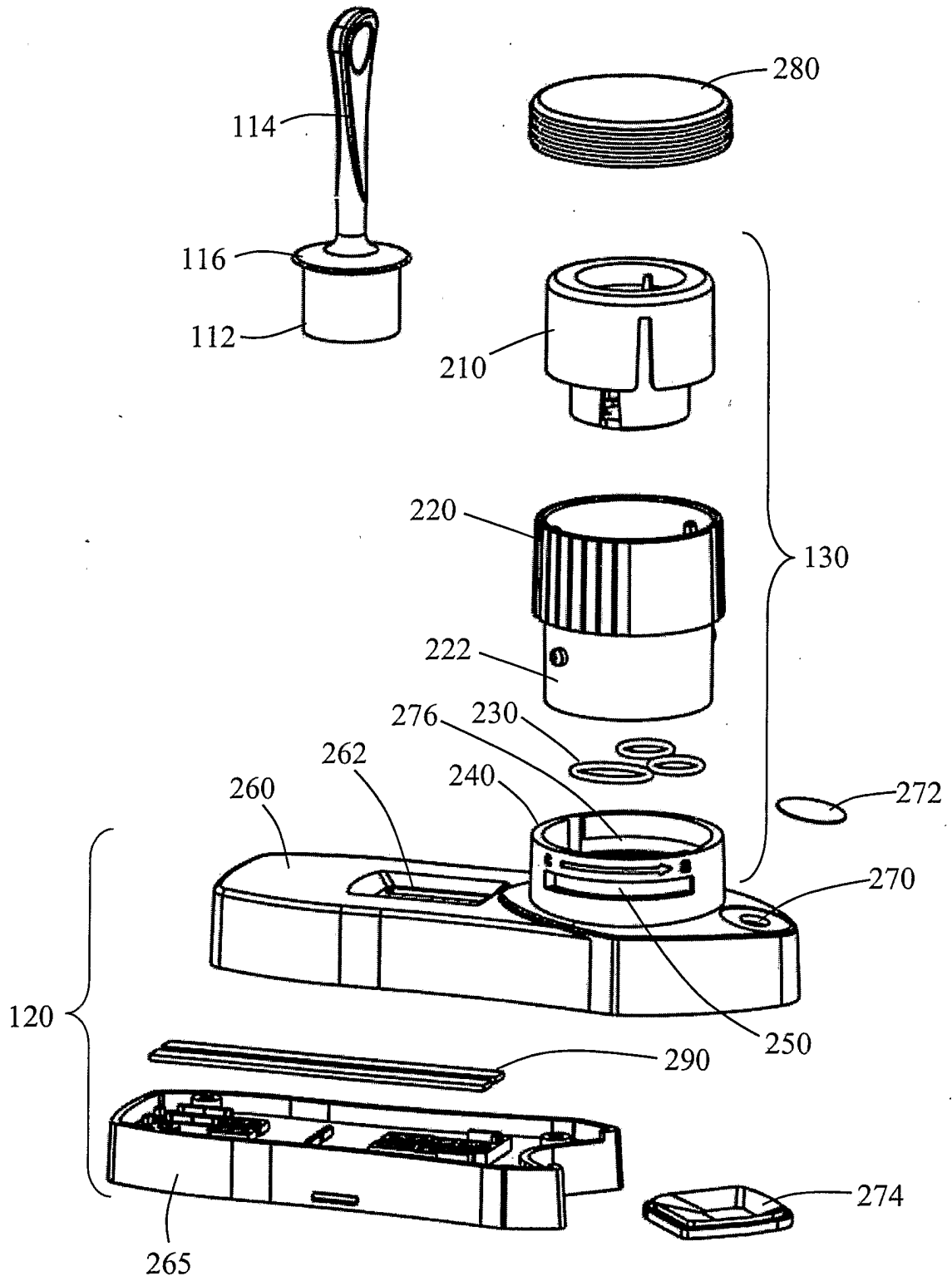

Figure 3

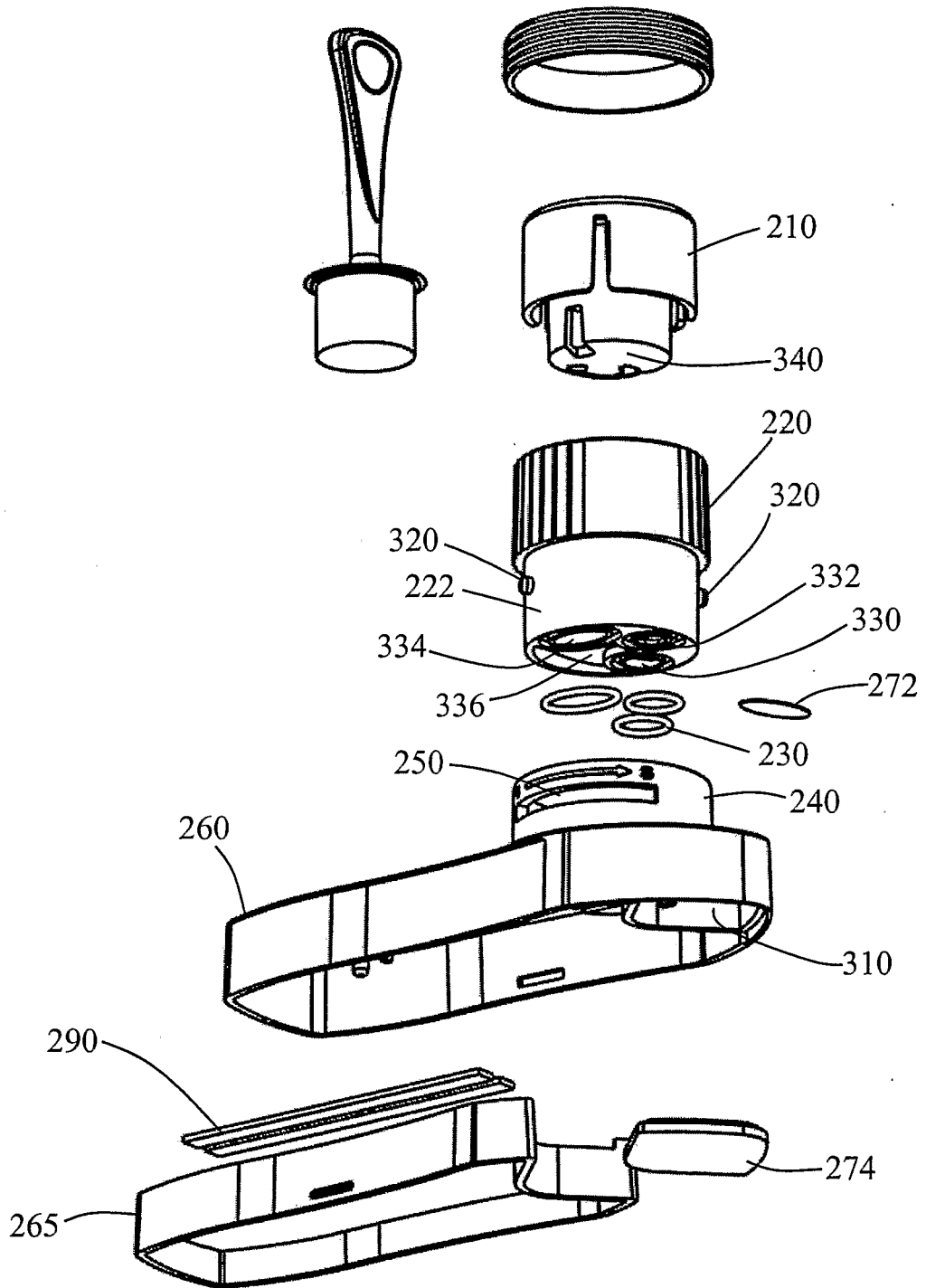

Figure 4

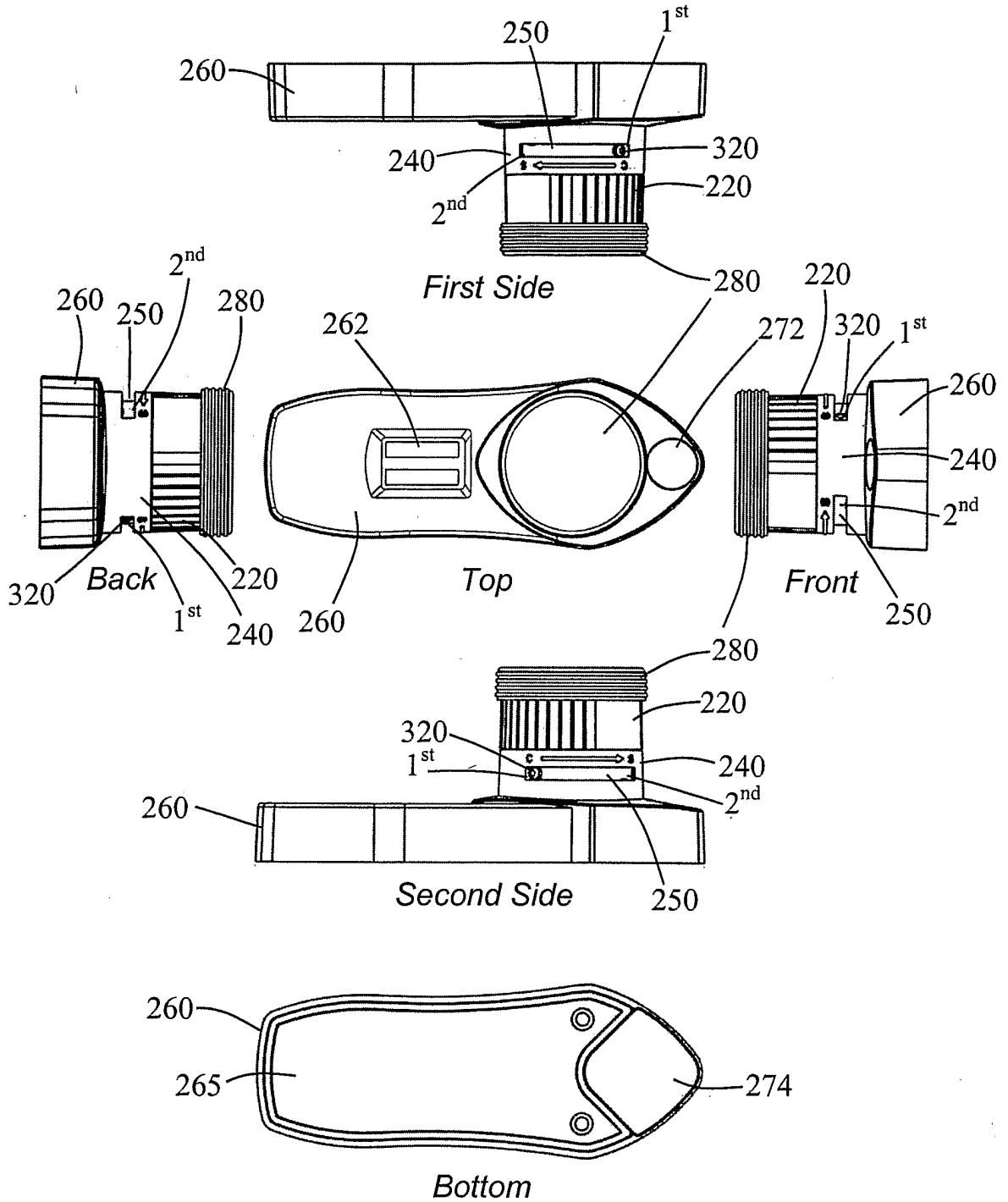

Figure 5

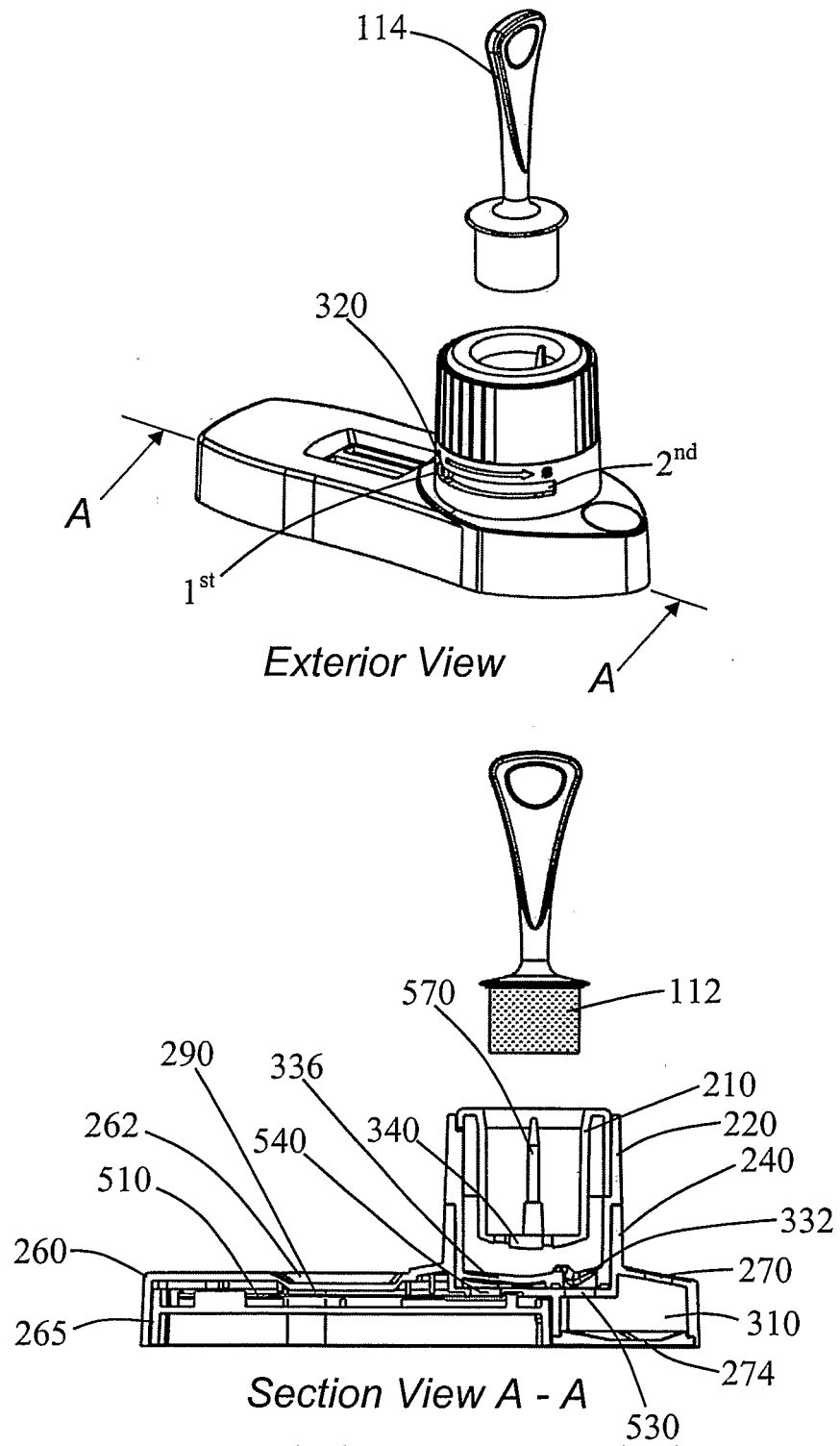

Figure 6

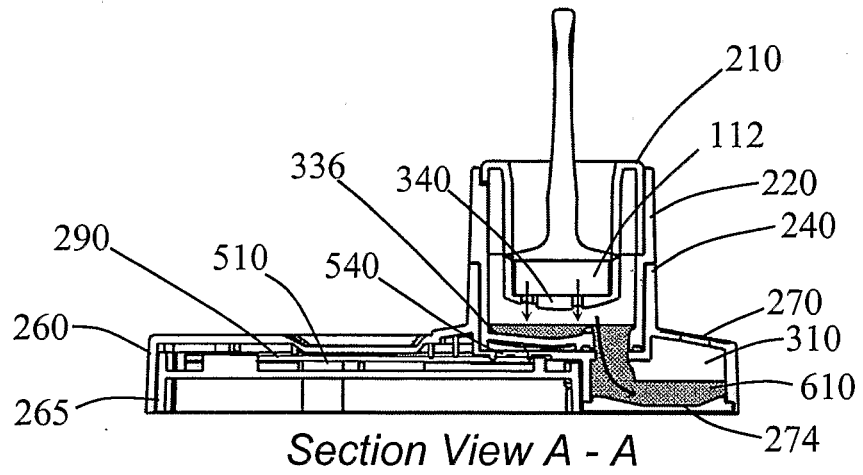
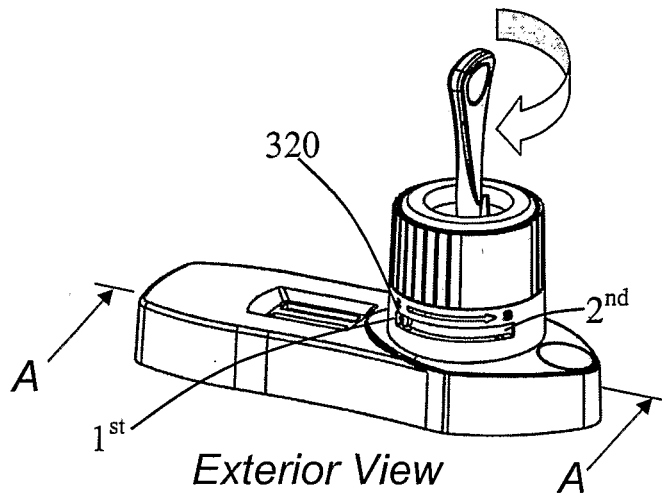

Figure 7

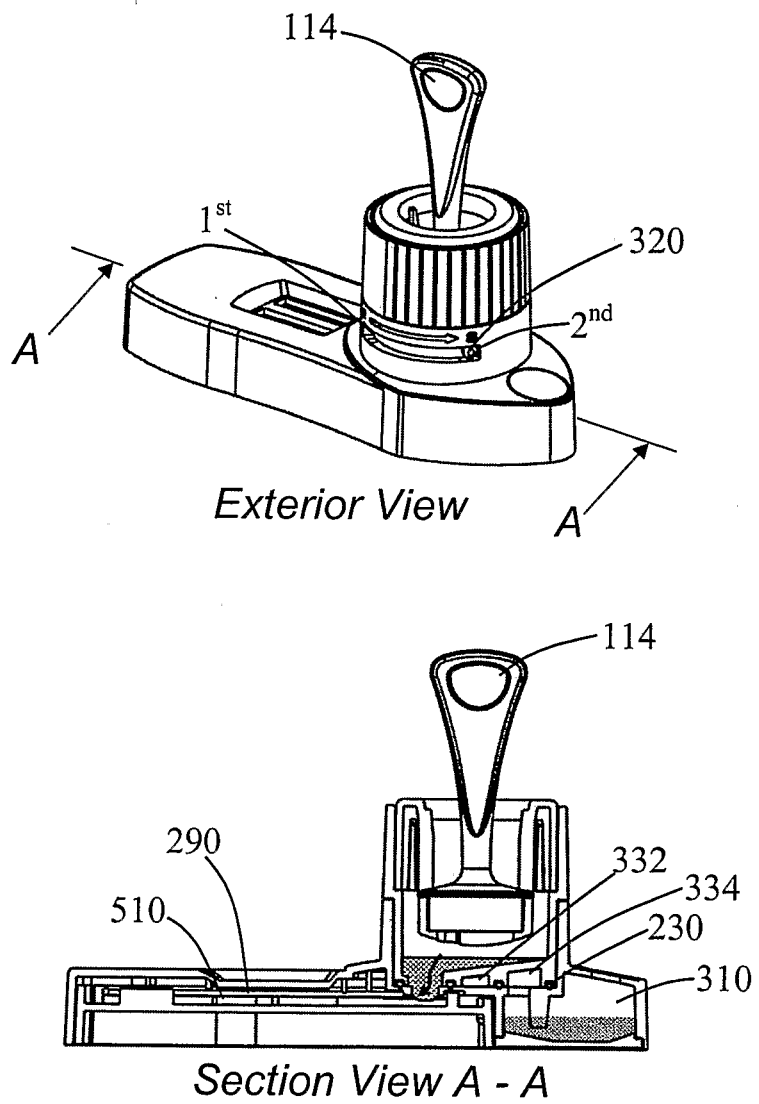
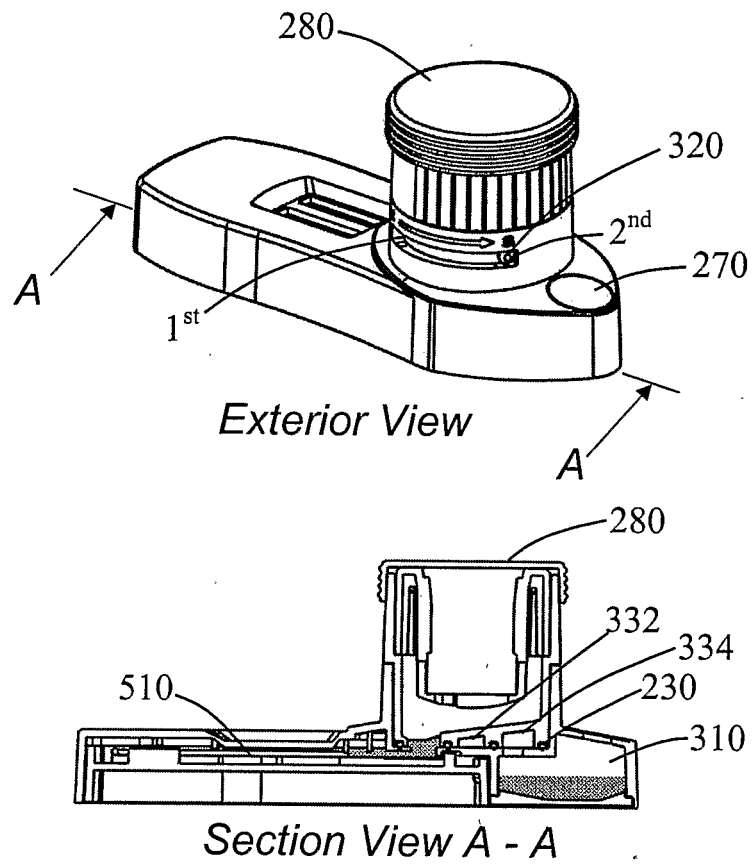

Figure 8



| | | | |
|----------------|---|---------|------------|
| 专利名称(译) | 快速样品分析和存储设备及使用方法 | | |
| 公开(公告)号 | EP1692501B1 | 公开(公告)日 | 2016-01-06 |
| 申请号 | EP2004819164 | 申请日 | 2004-11-15 |
| [标]申请(专利权)人(译) | OAKVILLE香港 | | |
| 申请(专利权)人(译) | OAKVILLE香港CO. , LIMITED | | |
| 当前申请(专利权)人(译) | 瑞士了Alere GMBH | | |
| [标]发明人 | TUNG HSIAOHO EDWARD WU YUZHANG DAI JIELIN YANG YING | | |
| 发明人 | TUNG, HSIAOHO, EDWARD WU, YUZHANG DAI, JIELIN YANG, YING | | |
| IPC分类号 | G01N33/48 A61B10/00 B01L3/00 G01N33/487 A61B5/00 A61M1/00 B65D81/00 G01N G01N31/22 | | |
| CPC分类号 | A61B10/0045 A61B10/0051 A61B10/007 A61B2010/0074 A61B2010/0077 B01L3/5023 B01L3/5027 B01L3/5029 B01L2200/027 B01L2200/0605 B01L2300/0825 B01L2400/0406 B01L2400/0644 G01N33/48714 | | |
| 代理机构(译) | LEE , NICHOLAS JOHN | | |
| 优先权 | 60/520437 2003-11-14 US | | |
| 其他公开文献 | EP1692501A4 EP1692501A2 | | |
| 外部链接 | Espacenet | | |

摘要(译)

本发明涉及用于确定流体样品中分析物的存在的装置和方法。该装置利用样品收集孔，用于将样品表达达到样品收集井中的表达板，驱动喷枪的柱塞，以及包含测试元件的测试隔室。该装置还将等分的流体样品保留在贮存器中，用于以后的确认测试。当柱塞下降到样品收集井中时，装置上的喷枪刺穿覆盖样品出口的易碎材料。当样品出口因此打开时，流体样品从样品收集杯流到测试隔室。在一个实施例中，当帽被施加到装置上时，柱塞下降。该装置可用于检测各种流体样品中的分析物的存在，例如唾液，口腔液等。本发明还提供了使用这些装置的方法，以及包含这些装置的试剂盒。

Figure 1

