



(11) **EP 1 653 849 B1**

(12) **EUROPEAN PATENT SPECIFICATION**

(45) Date of publication and mention of the grant of the patent:
06.10.2010 Bulletin 2010/40

(21) Application number: **04780949.6**

(22) Date of filing: **11.08.2004**

(51) Int Cl.:
A61B 5/15 (2006.01)

(86) International application number:
PCT/US2004/026190

(87) International publication number:
WO 2005/016125 (24.02.2005 Gazette 2005/08)

(54) **METHOD AND APPARATUS FOR BODY FLUID SAMPLING WITH INTEGRATED ANALYTE DETECTING MEMBER**

VERFAHREN UND GERÄT ZUR ENTNAHME VON KÖRPERFLÜSSIGKEITEN MIT INTEGRIERTEM ANALYTENNACHWEIS-ELEMENT

PROCEDE ET APPAREIL D'ECHANTILLONNAGE DE FLUIDES CORPORELS COMPRENANT UN ELEMENT DE DETECTION D'ANALYTE INTEGRE

(84) Designated Contracting States:
AT BE BG CH CY CZ DE DK EE ES FI FR GB GR HU IE IT LI LU MC NL PL PT RO SE SI SK TR

(30) Priority: **11.08.2003 US 494417 P**
11.08.2003 US 494401 P
05.08.2004 US 599792 P

(43) Date of publication of application:
10.05.2006 Bulletin 2006/19

(73) Proprietor: **Pelikan Technologies Inc.**
Palo Alto, CA 94303 (US)

(72) Inventors:
• **FREEMAN, Dominique, M.**
La Honda, CA 94020 (US)

- **ROSS, James**
Livermore, CA 94551 (US)
- **MARSOT, Travis**
Palo Alto, CA 94303 (US)
- **LUM, Paul**
Los Altos, CA 94022 (US)
- **MAUZE, Genapati**
Sunnyvale, CA 94085 (US)

(74) Representative: **Harris, Ian Richard et al**
D Young & Co LLP
120 Holborn
London EC1N 2DY (GB)

(56) References cited:
WO-A-02/00101 DE-C1- 10 057 832
DE-C1- 10 208 575 US-A1- 2003 083 685
US-B1- 6 472 220 US-B1- 6 592 745

EP 1 653 849 B1

Note: Within nine months of the publication of the mention of the grant of the European patent in the European Patent Bulletin, any person may give notice to the European Patent Office of opposition to that patent, in accordance with the Implementing Regulations. Notice of opposition shall not be deemed to have been filed until the opposition fee has been paid. (Art. 99(1) European Patent Convention).

Description

BACKGROUND OF THE INVENTION

[0001] Lancing devices are known in the medical health-care products industry for piercing the skin to produce blood for analysis. Typically, a drop of blood for this type of analysis is obtained by making a small incision in the fingertip, creating a small wound, which generates a small blood droplet on the surface of the skin.

[0002] Early methods of lancing included piercing or slicing the skin with a needle or razor. Current methods utilize lancing devices that contain a multitude of spring, cam and mass actuators to drive the lancet. These include cantilever springs, diaphragms, coil springs, as well as gravity plumbs used to drive the lancet. The device may be held against the skin and mechanically triggered to ballistically launch the lancet. Unfortunately, the pain associated with each lancing event using known technology discourages patients from testing. In addition to vibratory stimulation of the skin as the driver impacts the end of a launcher stop, known spring based devices have the possibility of firing lancets that harmonically oscillate against the patient tissue, causing multiple strikes due to recoil. This recoil and multiple strikes of the lancet is one major impediment to patient compliance with a structured glucose monitoring regime.

[0003] Success rate generally encompasses the probability of producing a blood sample with one lancing action, which is sufficient in volume to perform the desired analytical test. The blood may appear spontaneously at the surface of the skin, or may be "milked" from the wound. Milking generally involves pressing the side of the digit, or in proximity of the wound to express the blood to the surface. In traditional methods, the blood droplet produced by the lancing action must reach the surface of the skin to be viable for testing.

[0004] When using existing methods, blood often flows from the cut blood vessels but is then trapped below the surface of the skin, forming a hematoma. In other instances, a wound is created, but no blood flows from the wound. In either case, the lancing process cannot be combined with the sample acquisition and testing step. Spontaneous blood droplet generation with current mechanical launching system varies between launcher types but on average it is about 50% of lancet strikes, which would be spontaneous. Otherwise milking is required to yield blood. Mechanical launchers are unlikely to provide the means for integrated sample acquisition and testing if one out of every two strikes does not yield a spontaneous blood sample.

[0005] Many diabetic patients (insulin dependent) are required to self-test for blood glucose levels five to six times daily. The large number of steps required in traditional methods of glucose testing ranging from lancing, to milking of blood, applying blood to the test strip, and getting the measurements from the test strip discourages many diabetic patients from testing their blood glucose

levels as often as recommended. Tight control of plasma glucose through frequent testing is therefore mandatory for disease management. The pain associated with each lancing event further discourages patients from testing. Additionally, the wound channel left on the patient by known systems may also be of a size that discourages those who are active with their hands or who are worried about healing of those wound channels from testing their glucose levels.

[0006] Another problem frequently encountered by patients who must use lancing equipment to obtain and analyze blood samples is the amount of manual dexterity and hand-eye coordination required to properly operate the lancing and sample testing equipment due to retinopathies and neuropathies particularly, severe in elderly diabetic patients. For those patients, operating existing lancet and sample testing equipment can be a challenge. Once a blood droplet is created, that droplet must then be guided into a receiving channel of a small test strip or the like. If the sample placement on the strip is unsuccessful, repetition of the entire procedure including re-lancing the skin to obtain a new blood droplet is necessary. The manual dexterity and the relatively large number of devices used to sample and then test the blood challenges patients to keep to their testing regimes.

[0007] US 2003/0083685 A1 discloses a tissue penetration device and method of using same that may include a lancet module or sampling module. The sampling module may optionally be in a cartridge configuration and include sampling and analyzing functions, which may be integrated.

[0008] US 6,036,924 discloses a cassette containing cartridges for sampling blood from a patient. The cassette includes a container for storing a plurality of cartridges and at least one cartridge in the container. The cartridge includes a cartridge case and a lancet. The lancet has a tip and is housed in the cartridge case. The lancet can be driven to extend the tip outside the cartridge case for lancing the skin of the patient to yield blood. The container has a compartment that contains at least one cartridge. A cartridge from the compartment can be loaded onto a glucometer that drives the lancet in the cartridge to lance the skin of a patient.

[0009] WO 02/00101 A2 discloses an analyte monitoring device having a housing and including a plurality of needles, each having a tip which may be in a retracted position or a position where the tip is extended from the housing a distance adapted to pierce skin, a needle pushing apparatus movable to separately engage the needles to move them from the retracted position to the extended position, an energy source located within the housing and a plurality of analysis sites. The analysis sites comprise an analysis preparation and are adapted to receive liquid from the needles to wet the analysis preparation. A light source is adapted to direct light at the analysis sites and detectors are adapted to receive light from the analysis sites.

[0010] DE 100 57 832 C1 discloses a blood analysis

device that has a syringe mounted in a casing and operated by an external plunger. An annular mounting carries needles, each of which is mounted behind a test strip. The mounting is swivelled so that a needle cooperates with the syringe and the needle can be pushed through the test strip and an aperture in the casing to take a blood sample. DE 102 08 575 discloses a blood analysis device having first and second cartridge containing, respectively, penetrating members and analyte detecting members, the analyte detecting members comprising contact electrodes.

SUMMARY OF THE INVENTION

[0011] Aspects of the present invention are set out in the appended claims.

[0012] The present invention provides solutions for at least some of the drawbacks discussed above. Specifically, some embodiments of the present invention provide an improved, integrated fluid sampling device. To improve device integration, devices and methods for connecting analyte detecting members to the cartridge are desired. One of the problems that this invention solves is the ability to smoothly integrate the analyte detecting members to a penetrating member cartridge. At least some of these and other objectives described herein will be met by embodiments of the present invention.

[0013] In one aspect of the present invention, the invention relates to using an electronic tissue penetration device to drive a penetrating member into tissue, sample the body fluid, and measure analyte levels in the body fluid using a cartridge having a plurality of analyte detecting member mounted about the circumference of the cartridge.

[0014] In one embodiment, the present invention relates to a novel design for locating a sensor or multiple sensors onto a separate component which can be made to fit integral to a penetrating member cartridge and allows the blood sample to access the sensor port. The present invention relates to using the electronic tissue penetration device to drive a lancet into the skin of a finger or other body part and seamlessly collect the blood sample into a test cartridge for analysis. Analysis takes place on the sample cartridge by either electrochemical or optical methods. The result is delivered to the user at the time of or shortly following the lancing. In some embodiments, as many as 100 tests may be carried out on one cartridge.

[0015] It may be desired in some embodiments that the penetrating member and the analyte detecting member are in the same chamber at the time of penetrating member actuation.

[0016] Embodiments of the present invention would also lend themselves to manufacture as separate from the launcher disposable. In addition the sterilization procedure would be somewhat simplified, because the sensor ring subassembly is fixed to the separately sterilized lancet cartridge.

[0017] The integrated system of multiple lancets combined with multiple sensors may reside on a disposable cartridge. This cartridge containing the lancets and the sensors can be manufactured as separate units and assembled to form a single disposable cartridge for monitoring, metabolites from biological fluids.

[0018] The present invention may provide a multiple lancet multiple sensor solution for body fluid sampling and testing. Previously a system has been described comprising a lancet driver, a cartridge having a plurality of lancets and a plurality of analyte sensors, wherein the lancet driver actuates the lancets to penetrate tissue and wherein used lancets and sensors remain coupled to the cartridge. The cartridge containing used lancets and used sensors is the only disposable of the lancing system. This cartridge containing the lancets and the sensors can be manufactured as separate units (lancet cartridge and sensor cartridge) and assembled to form a single disposable cartridge.

[0019] A separate multiple sensor disposable can be manufactured for assembly with a multiple lancet disposable and assembled into a single disposable cartridge.

[0020] In one aspect, the present invention is intended to allow the conduction of sensory device signals to pass through a support and insulated plate structure. The insulated plate maybe fabricated from polymer materials, known to those practicing the arts, of which the conductive material is a deposited carbon based compound. The deposition of such a thick film is generated thru the art known as "screen printing" or "thick film lithography". The thick film is annealed as to remove any liquid carrier and to conductive as well as structure sound to support the deposition of sensory electrochemical material and devices. The thickness of such conductive material is typically in the range of 1 to 10 "mils" or 100's of "microns".

[0021] Embodiments of the present invention may provide the ability to deposit sensory material on the topside of the film for exposure to bodily fluids via a lancing, sampling, and capturing structure or device. The invention allows the electrical signals from the sensory material to be conducted and transported to the instrumentation electronics on the backside of the device such that the electrical conductors are not exposed to the bodily fluids. Also the topside of the film containing the sensory material adjacent to the lancing and sample capturing structures may be sterilized or cleaned and stored until it becomes necessary to be utilized.

[0022] In one aspect of the present invention, the invention relates to using an electronic tissue penetration device to drive a penetrating member into tissue, sample the body fluid, and measure analyte levels in the body fluid using a sensor cartridge having a support with sensors on one side, conductor pads on the other side, where the sensors are coupled through via hole structures.

[0023] The invention relates to the conduction of sensory signals on one side of an insulated polymer layer and its sensory signal conduction through and upon another side of the same polymer layer.

[0024] The technical field relates to thick film conductor depositions for the purpose of providing sensory device placement, signal conduction, and isolation from environments detrimental to the sensory device storage and integrity prior to utilization.

[0025] The present invention addresses the minimal energy for transporting body fluid to the analyte detecting device.

[0026] In one embodiment, the device includes a cartridge containing a plurality of penetrating members and a second portion having a plurality of analyte detecting members and where the second portion is coupled to the first cartridge. The analyte detecting members on the second portion are positioned to receive body fluid for a wound created by one of the penetrating members exiting the first cartridge. Some embodiments of the present invention do not have through connections. In some embodiments, fluid does not need to flow around a 90 degree bend.

[0027] Some embodiments may have a rotary ribbon with a plurality of analyte detecting members on the ribbon. Another embodiment may have a cage to hold the ribbon in place. Other embodiments may have individual analyte testing members slipped into the cage. PSA layer or film may be used to form the analyte detecting member. Some embodiments may have a transition from mesh to capillary or capillary to mesh for the fluid transport.

[0028] In some embodiments, the front face is the sensor substrate. The electrode contacts or connectors would interact from the inner diameter. This also provides a more robust configuration since the substrate on the outer face would allow for easier handling by assembly devices during manufacturing. There may be an inactive surface that the device is handling and does not disturb the sensor chemistry.

[0029] In some embodiments, with the analyte detecting member reversed and attached directly to a cartridge, the device may be much thinner since one layer is removed (since the cartridge surface helps to form the area holding the fluid), in the range of about 200 microns in thickness. The blood or body fluid may need to traverse a portion of the thickness (for non flipped versions).

[0030] In some embodiments, there may not be a need for a second film if the disc surface is treated and will act as a second surface. The treatment may be a hydrophilic treatment. This also eliminates the need to jump the gap.

[0031] The system may further comprise means for coupling the force generator with one of the penetrating members.

[0032] The system may further comprise a penetrating member sensor positioned to monitor a penetrating member coupled to the force generator, the penetrating member sensor configured to provide information relative to a depth of penetration of a penetrating member through a skin surface.

[0033] The depth of penetration may be about 100 to 2500 microns.

[0034] The depth of penetration may be about 500 to 750 microns.

[0035] The depth of penetration may be, in this non-limiting example, no more than about 1000 microns beyond a stratum corneum thickness of a skin surface.

[0036] The depth of penetration may be no more than about 500 microns beyond a stratum corneum thickness of a skin surface.

[0037] The depth of penetration may be no more than about 300 microns beyond a stratum corneum thickness of a skin surface.

[0038] The depth of penetration may be less than a sum of a stratum corneum thickness of a skin surface and 400 microns.

[0039] The penetrating member sensor may be further configured to control velocity of a penetrating member.

[0040] The active penetrating member may move along a substantially linear path into the tissue.

[0041] The active penetrating member may move along an at least partially curved path into the tissue.

[0042] The driver may be a voice coil drive force generator.

[0043] The driver may be a rotary voice coil drive force generator.

[0044] The penetrating member sensor may be coupled to a processor with control instructions for the penetrating member driver.

[0045] The processor may include a memory for storage and retrieval of a set of penetrating member profiles utilized with the penetrating member driver.

[0046] The processor may be utilized to monitor position and speed of a penetrating member as the penetrating member moves in a first direction.

[0047] The processor may be utilized to adjust an application of force to a penetrating member to achieve a desired speed of the penetrating member.

[0048] The processor may be utilized to adjust an application of force to a penetrating member when the penetrating member contacts a target tissue so that the penetrating member penetrates the target tissue within a desired range of speed.

[0049] The processor may be utilized to monitor position and speed of a penetrating member as the penetrating member moves in the first direction toward a target tissue, wherein the application of a launching force to the penetrating member is controlled based on position and speed of the penetrating member.

[0050] The processor may be utilized to control a withdraw force to the penetrating member so that the penetrating member moves in a second direction away from the target tissue.

[0051] In the first direction, the penetrating member may move toward the target tissue at a speed that is different than a speed at which the penetrating member moves away from the target tissue.

[0052] In the first direction the penetrating member may move toward the target tissue at a speed that is greater than a speed at which the penetrating member

moves away from the target tissue.

[0053] The speed of a penetrating member in the first direction may be the range of about 2.0 to 10.0 m/sec.

[0054] The average velocity of the penetrating member during a tissue penetration stroke in the first direction may be about 100 to about 1000 times greater than the average velocity of the penetrating member during a withdrawal stroke in a second direction.

[0055] A further understanding of the nature and advantages of the invention will become apparent by reference to the remaining portions of the specification and drawings.

BRIEF DESCRIPTION OF THE DRAWINGS

[0056]

Figure 1 is a perspective view illustrating a system, according to an embodiment not part of the invention for use in piercing skin to obtain a blood sample; Figure 2 is a plan view of a portion of a replaceable penetrating member cartridge forming part of the system;

Figure 3 is a cross-sectional end view on 3-3 in Figure 2;

Figure 4 is a cross-sectional end view on 4-4 in Figure 2;

Figure 5 is a perspective view of an apparatus forming part of the system and used for manipulating components of the cartridge, illustrating pivoting of a penetrating member accelerator in a downward direction;

Figure 6A is a view similar to Figure 5, illustrating how the cartridge is rotated or advanced;

Figure 6B is a cross-sectional side view illustrating how the penetrating member accelerator allows for the cartridge to be advanced;

Figure 7A and 7B are views similar to Figures 6A and 6B, respectively, illustrating pivoting of the penetrating member accelerator in an opposite direction to engage with a select one of the penetrating members in the cartridge;

Figures 8A and 8B are views similar to Figures 7A and 7B, respectively, illustrating how the penetrating member accelerator moves the selected penetrating member to pierce skin;

Figures 9A and 9B are views similar to Figures 8A and 8B, respectively, illustrating how the penetrating member accelerator returns the penetrating member to its original position;

Figure 10 is a block diagram illustrating functional components of the apparatus; and

Figure 11 is an end view illustrating a cartridge according to an optional embodiment that allows for better adhesion of sterilization barriers.

Figure 12 is a cross-sectional view of an embodiment not part of the invention.

Figure 13 is a cross-sectional view of an embodiment

not part of the invention.

Figure 14 is a cross-sectional view illustrating a low-friction coating applied to one penetrating member contact surface.

Figure 15 is a cross-sectional view illustrating a coating applied to one penetrating member contact surface which increases friction and improves the microscopic contact area between the penetrating member and the penetrating member contact surface.

Figure 16 illustrates a portion of a penetrating member cartridge having an annular configuration with a plurality of radially oriented penetrating member slots and a distal edge of a drive member disposed in one of the penetrating member slots.

Figure 17 is an elevational view in partial longitudinal section of a coated penetrating member in contact with a coated penetrating member contact surface.

Figure 18 illustrates an embodiment of a lancing device not part of the invention.

Figure 19 is a perspective view of a portion of a penetrating member cartridge base plate having a plurality of penetrating member slots and drive member guide slots disposed radially inward of and aligned with the penetrating member slots.

Figures 20-22 illustrate a penetrating member cartridge in section, a drive member, a penetrating member and the tip of a patient's finger during three sequential phases of a lancing cycle.

Figure 23 illustrates an embodiment of a penetrating member cartridge not part of the invention.

Figure 24 is an exploded view of a portion of the penetrating member cartridge of Figure 12.

Figures 25 and 26 illustrate a multiple layer sterility barrier disposed over a penetrating member slot being penetrated by the distal end of a penetrating member during a lancing cycle.

Figures 27 and 28 illustrate an embodiment of a drive member coupled to a driver wherein the drive member includes a cutting member having a sharpened edge which is configured to cut through a sterility barrier of a penetrating member slot during a lancing cycle in order for the drive member to make contact with the penetrating member.

Figures 29 and 30 illustrate an embodiment of a penetrating member slot in longitudinal section having a ramped portion disposed at a distal end of the penetrating member slot and a drive member with a cutting edge at a distal end thereof for cutting through a sterility barrier during a lancing cycle.

Figures 31-34 illustrate drive member slots in a penetrating member cartridge wherein at least a portion of the drive member slots have a tapered opening which is larger in transverse dimension at the top of the drive member slot than at the bottom of the drive member slot.

Figures 35-37 illustrate an embodiment of a penetrating member cartridge and penetrating member

drive member wherein the penetrating member drive member has a contoured jaws configured to grip a penetrating member shaft.

Figures 38 and 39 show a portion of a lancing device having a lid that can be opened to expose a penetrating member cartridge cavity for removal of a used penetrating member cartridge and insertion of a new penetrating member cartridge.

Figures 40 and 41 illustrate a penetrating member cartridge that has penetrating member slots on both sides.

Figures 42-44 illustrate end and perspective views of a penetrating member cartridge having a plurality of penetrating member slots formed from a corrugated surface of the penetrating member cartridge.

Figures 45-48 illustrate embodiments of a penetrating member and drive member wherein the penetrating member has a slotted shaft and the drive member has a protuberance configured to mate with the slot in the penetrating member shaft.

Figure 49 is a perspective view of a cartridge not part of the invention.

Figures 50 and 51 show close-ups of outer peripheries various cartridges.

Figure 52 is a perspective view of an underside of a cartridge.

Figure 53A shows a top down view of a cartridge and the punch and pusher devices.

Figure 53B is a perspective view of one embodiment of a punch plate.

Figures 54A-54G show a sequence of motion for the punch plate, the cartridge, and the cartridge pusher. Figures 55A-55B show cross-sections of the system not part of the invention.

Figure 56A shows a perspective view of the system not part of the invention.

Figures 56B-56D are cut-away views showing mechanisms not part of the invention.

Figures 57-65B show optional embodiments not part of the invention.

Figure 66-68 shows a still further embodiment of a cartridge not part of the invention.

Figures 69A-69L show the sequence of motions associated with an optional embodiment of a cartridge not part of the invention.

Figure 70-72 show views of a sample modules used with still further embodiments of a cartridge not part of the invention.

Figure 73 shows a cartridge with a sterility barrier and an analyte detecting member layer.

Figure 74-78 show still further embodiments of analyte detecting members coupled to a cartridge.

Figures 79-84 show optional configurations for a cartridge not part of the invention.

Figure 85 shows a see-through view of one embodiment of a system not part of the invention.

Figure 86 is a schematic of an optional embodiment of a system not part of the invention.

Figures 87A-87B show still further embodiments of cartridges not part of the invention.

Figure 88 shows a cartridge having an array of analyte detecting members.

Figures 89-90 show embodiments of illumination systems not part of the invention.

Figures 91-96 show further embodiments using optical methods for analyte detection.

Figure 97 shows a perspective view of a cartridge not part of the invention.

Figure 98 shows one embodiment of a ring for use with the cartridge of Figure 97.

Figures 99 and 100 show top and bottom views of the devices of Figures 97 and 98 coupled together.

Figure 101 shows a single penetrating member device for use with a plurality of analyte detecting members.

Figures 102 and 103 show various views of a device for use with analyte measurement.

Figure 104 shows an embodiment of a device for use with a cartridge not part of the invention.

Figure 105 and 106 show cross-sectional views of a device not part of the invention.

Figure 107 shows a ribbon having a plurality of analyte detecting members.

Figure 108 shows a cross-sectional view of one embodiment not part of the invention.

Figure 109 shows an embodiment with different electrode orientations.

Figures 110-112 show various views of analyte detecting members the present invention.

Figure 113 shows a perspective view of one embodiment of the present invention.

Figures 114-115 show various cross-sectional views of embodiments of the present invention.

Figures 116 to 118 show front views with various electrode layouts.

Figures 119 to 120 shows side views of analyte detecting members with vias.

Figures 121 to 124 show various views of electrodes for use with the present invention.

Figures 125 to 127 show various perspective views of embodiments not part of the invention.

45 DESCRIPTION OF THE SPECIFIC EMBODIMENTS

[0057] The present invention provides a multiple analyte detecting member solution for body fluid sampling. Specifically, some embodiments of the present invention provides a multiple analyte detecting member and multiple lancet solution to measuring analyte levels in the body. The invention may use a high density design. It may use lancets of smaller size, such as but not limited to diameter or length, than known lancets. The device may be used for multiple lancing events without having to remove a disposable from the device. The invention may provide improved sensing capabilities. At least some of these and other objectives described herein will be

met by embodiments of the present invention.

[0058] It is to be understood that both the foregoing general description and the following detailed description are exemplary and explanatory only and are not restrictive of the invention, as claimed. It must be noted that, as used in the specification and the appended claims, the singular forms "a", "an" and "the" include plural referents unless the context clearly dictates otherwise. Thus, for example, reference to "a material" may include mixtures of materials, reference to "a chamber" may include multiple chambers, and the like. References cited herein are hereby incorporated by reference in their entirety, except to the extent that they conflict with teachings explicitly set forth in this specification.

[0059] In this specification and in the claims which follow, reference will be made to a number of terms which shall be defined to have the following meanings:

"Optional" or "optionally" means that the subsequently described circumstance may or may not occur, so that the description includes instances where the circumstance occurs and instances where it does not. For example, if a device optionally contains a feature for analyzing a blood sample, this means that the analysis feature may or may not be present, and, thus, the description includes structures wherein a device possesses the analysis feature and structures wherein the analysis feature is not present.

[0060] "Analyte detecting member" refers to any use, singly or in combination, of chemical test reagents and methods, electrical test circuits and methods, physical test components and methods, optical test components and methods, and biological test reagents and methods to yield information about a blood sample. Such methods are well known in the art and may be based on teachings of, e.g. Tietz Textbook of Clinical Chemistry, 3d Ed., Sec. V, pp. 776-78 (Burtis & Ashwood, Eds., W.B. Saunders Company, Philadelphia, 1999); U.S. Pat. No. 5,997,817 to Chrismore et al. (Dec. 7, 1999); U.S. Pat. No. 5,059,394 to Phillips et al. (Oct. 22, 1991); U.S. Pat. No. 5,001,054 to Wagner et al. (Mar. 19, 1991); and U.S. Pat. No. 4,392,933 to Nakamura et al. (July 12, 1983), as well as others. Analyte detecting member may include tests in the sample test chamber that test electrochemical properties of the blood, or they may include optical means for sensing optical properties of the blood (e.g. oxygen saturation level), or they may include biochemical reagents (e.g. antibodies) to sense properties (e.g. presence of antigens) of the blood. The analyte detecting member may comprise biosensing or reagent material that will react with an analyte in blood (e.g. glucose) or other body fluid so that an appropriate signal correlating with the presence of the analyte is generated and can be read by the reader apparatus. By way of example and not limitation, analyte detecting member may be "associated with", "mounted within", or "coupled to" a chamber or other structure when the analyte detecting member partici-

pates in the function of providing an appropriate signal about the blood sample to the reader device. Analyte detecting member may also include nanowire analyte detecting members as described herein.

5 Analyte detecting member may use any, singly or in combination, potentiometric, coulometric, or other method useful for detection of analyte levels.

[0061] Figures 1-11 of the accompanying drawings illustrates one embodiment of a system 10 for piercing tissue to obtain a blood sample. The system 10 may include a replaceable cartridge 12 and an apparatus 14 for removably receiving the cartridge 12 and for manipulating components of the cartridge 12.

[0062] Referring jointly to Figures 1 and 2, the cartridge 12 may include a plurality of penetrating members 18. The cartridge 12 may be in the form of a circular disc and has an outer circular surface 20 and an opening forming an inner circular surface 22. A plurality of grooves 24 are formed in a planar surface 26 of the cartridge 12. Each groove 24 is elongated and extends radially out from a center point of the cartridge 12. Each groove 24 is formed through the outer circular surface 20. Although not shown, it should be understood that the grooves 24 are formed over the entire circumference of the planar surface 26. As shown in Figures 3 and 4, each groove 24 is relatively narrow closer to the center point of the cartridge 12 and slightly wider further from the center point. These grooves 24 may be molded into the cartridge 12, machined into the cartridge, forged, pressed, or formed using other methods useful in the manufacture of medical devices.

[0063] In the present embodiment, each penetrating member 18 has an elongated body 26 and a sharpened distal end 27 having a sharp tip 30. The penetrating member 18 may have a circular cross-section with a diameter in this embodiment of about 0.315 mm. All outer surfaces of the penetrating member 18 may have the same coefficient of friction. The penetrating member may be, but is not necessarily, a bare lancet. The lancet is "bare", in the sense that no raised formations or molded parts are formed thereon that are complementarily engageable with another structure. Traditional lancets include large plastic molded parts that are used to facilitate engagement. Unfortunately, such attachments add size and cost. In the most basic sense, a bare lancet or bare penetrating member is an elongate wire having sharpened end. If it is of sufficiently small diameter, the tip may be penetrating without having to be sharpened. A bare lancet may be bent and still be considered a bare lancet. The bare lancet in one embodiment may be made of one material.

[0064] In the present embodiment, each penetrating member 18 is located in a respective one of the grooves 24. The penetrating members 18 have their sharpened distal ends 27 pointed radially out from the center point of the cartridge 12. A proximal end of each penetrating member 15 may engage in an interference fit with opposing sides of a respective groove 24 as shown in Figure

3. Other embodiments of the cartridge 12 may not use such an interference fit. As a nonlimiting example, they may use a fracturable adhesive to releasably secure the penetrating member 18 to the cartridge 12. As shown in Figure 4, more distal portions of the penetrating member 18 are not engaged with the opposing sides of the groove 24 due to the larger spacing between the sides.

[0065] The cartridge 12 may further include a sterilization barrier 28 attached to the upper surface 26. The sterilization barrier 28 is located over the penetrating members 18 and serves to insulate the penetrating members 18 from external contaminants. The sterilization barrier 28 is made of a material that can easily be broken when an edge of a device applies a force thereto. The sterilization barrier 28 alone or in combination with other barriers may be used to create a sterile environment about at least the tip of the penetrating member prior to lancing or actuation. The sterilization barrier 28 may be made of a variety of materials such as but not limited to metallic foil, aluminum foil, paper, polymeric material, or laminates combining any of the above. Other details of the sterilization barrier are detailed herein.

[0066] In the present embodiment, the apparatus 14 may include a housing 30, an initiator button 32, a penetrating member movement subassembly 34, a cartridge advance subassembly 36, batteries 38, a capacitor 40, a microprocessor controller 42, and switches 44. The housing 30 may have a lower portion 46 and a lid 48. The lid 48 is secured to the lower portion 46 with a hinge 50. The lower portion 46 may have a recess 52. A circular opening 54 in the lower portion 46 defines an outer boundary of the recess 52 and a level platform 56 of the lower portion 46 defines a base of the recess 52.

[0067] In use, the lid 48 of the present embodiment is pivoted into a position as shown in Figure 1. The cartridge 12 is flipped over and positioned in the recess 52. The planar surface 26 rests against the level platform 56 and the circular opening 54 contacts the outer circular surface 20 to prevent movement of the cartridge 12 in a plane thereof. The lid 48 is then pivoted in a direction 60 and closes the cartridge 12.

[0068] Referring to the embodiment shown in Figure 5, the penetrating member movement subassembly 34 includes a lever 62, a penetrating member accelerator 64, a linear actuator 66, and a spring 68. Other suitable actuators including but not limited to rotary actuators are described in commonly assigned, copending U.S. Patent Application Ser. No. 10/127,395 (Attorney Docket No. 38187-2551) filed April 19, 2002. The lever 62 may be pivotably secured to the lower portion 46. The button 32 is located in an accessible position external of the lower portion 46 and is connected by a shaft 70 through the lower portion 46 to one end of the lever 62. The penetrating member accelerator 64 is mounted to an opposing end of the lever 62. A user depresses the button 32 in an upward direction 66 so that the shaft 70 pivots the end of the lever 62 to which it is connected in an upward direction. The opposing end of the lever pivots in a down-

ward direction 66. The spring 46 is positioned between the button 32 and the base 40 and compresses when the button 32 is depressed to create a force that tends to move the button 32 down and pivot the penetrating member accelerator upward in a direction opposite to the direction 64.

[0069] Referring to Figures 6A and 6B in this particular embodiment, the movement of the button into the position shown in Figure 5 also causes contact between a terminal 74 on the shaft 20 with a terminal 70 secured to the lower portion 46. Contact between the terminals 74 and 76 indicates that the button 32 has been fully depressed. With the button 32 depressed, the cartridge 12 can be rotated without interference by the penetrating member actuator 64. To this effect, the cartridge advancer subsystem 36 includes a pinion gear 80 and a stepper motor 82. The stepper motor 82 is secured to the lower portion 46. The pinion gear 80 is secured to the stepper motor 82 and is rotated by the stepper motor 82. Teeth on the pinion gear 80 engage with teeth on the inner circular surface 22 of the cartridge 12. Rotation of the pinion gear 80 causes rotation of the cartridge 12 about the center point thereof. Each time that the terminals 74 and 76 make contact, the stepper motor 82 is operated to rotate the cartridge 12 through a discrete angle equal to an angular spacing from a centerline of one of the penetrating members 18 to a centerline of an adjacent penetrating member. A select penetrating member 18 is so moved over the penetrating member accelerator 64, as shown in Figure 6B. Subsequent depressions of the button 32 will cause rotation of subsequent adjacent penetrating members 18 into a position over the penetrating member accelerator 64.

[0070] The user then releases pressure from the button, as shown in Figure 7A. The force created by the spring 68 or other resilient member moves the button 32 in a downward direction 76. The shaft 70 is pivotably secured to the lever 62 so that the shaft 70 moves the end of the lever 62 to which it is connected down. The opposite end of the lever 62 pivots the penetrating member accelerator 64 upward in a direction 80. As shown in Figure 7B, an edge 82 of the penetrating member accelerator 64 breaks through a portion of the sterilization barrier 28 and comes in to physical contact with a lower side surface of the penetrating member 18.

[0071] Referring to Figure 8A, the linear actuator 66 includes separate advancing coils 86A and retracting coils 86B, and a magnetizable slug 90 within the coils 86A and 86B. The coils 86A and 86B are secured to the lower portion of 46, and the slug 90 can move within the coils 86A and 88B. Once the penetrating member accelerator 64 is located in the position shown in Figures 7A and 7B, electric current is provided to the advancing coils 86 only. The current in the advancing coils 86 creates a force in a direction 88 on the slug 90 according to conventional principles relating to electromagnetics.

[0072] A bearing 91 is secured to the lever and the penetrating member accelerator 64 has a slot 92 over

the bearing 91. The slot 92 allows for the movement of the penetrating member accelerator 64 in the direction 88 relative to the lever 62, so that the force created on the slug moves the penetrating member accelerator 64 in the direction 88.

[0073] The spring 68 is not entirely relaxed, so that the spring 68, through the lever 62, biases the penetrating member accelerator 64 against the lower side surface of the penetrating member 18 with a force F1. The penetrating member 18 rests against a base 88 of the cartridge 12. An equal and opposing force F2 is created by the base 88 on an upper side surface of the penetrating member 18.

[0074] The edge 82 of the penetrating member accelerator 64 has a much higher coefficient of friction than the base 88 of the cartridge 12. The higher coefficient of friction of the edge contributes to a relatively high friction force F3 on the lower side surface of the penetrating member 18. The relatively low coefficient of friction of the base 88 creates a relatively small friction force F4 on the upper side surface of the penetrating member 18. A difference between the force F3 and F4 is a resultant force that accelerates the penetrating member in the direction 88 relative to the cartridge 12. The penetrating member is moved out of the interference fit illustrated in Figure 3. The bare penetrating member 18 is moved without the need for any engagement formations on the penetrating member. Current devices, in contrast, often make use a plastic body molded onto each penetrating member to aid in manipulating the penetrating members. Movement of the penetrating member 18 moves the sharpened end thereof through an opening 90 in a side of the lower portion 46. The sharp end 30 of the penetrating member 18 is thereby moved from a retracted and safe position within the lower portion 46 into a position wherein it extends out of the opening 90. Accelerated, high-speed movement of the penetrating member is used so that the sharp tip 30 penetrates skin of a person. A blood sample can then be taken from the person, typically for diabetic analysis.

[0075] Reference is now made to Figures 9A and 9B. After the penetrating member is accelerated (for example, but not limitation, less than .25 seconds thereafter), the current to the accelerating coils 86A is turned off and the current is provided to the retracting coils 86B. The slug 90 moves in an opposite direction 92 together with the penetrating member accelerator 64. The penetrating member accelerator 64 then returns the used penetrating member into its original position, i.e., the same as shown in Figure 7B.

[0076] Subsequent depression of the button as shown in Figure 5 will then cause one repetition of the process described, but with an adjacent sterile penetrating member. Subsequent sterile penetrating members can so be used until all the penetrating members have been used, i.e., after one complete revolution of the cartridge 12. In this embodiment, a second revolution of the cartridge 12 is disallowed to prevent the use of penetrating members that have been used in a previous revolution and have

become contaminated. The only way in which the user can continue to use the apparatus 14 is by opening the lid 48 as shown in Figure 1, removing the used cartridge 12, and replacing the used cartridge with another cartridge. A detector (not shown) detects whenever a cartridge is removed and replaced with another cartridge. Such a detector may be but is not limited to an optical sensor, an electrical contact sensor, a bar code reader, or the like.

[0077] Figure 10 illustrates the manner in which the electrical components may be functionally interconnected for the present embodiment. The battery 38 provides power to the capacitor 40 and the controller 42. The terminal 76 is connected to the controller 42 so that the controller recognizes when the button 32 is depressed. The capacitor to provide power (electric potential and current) individually through the switches (such as field-effect transistors) to the advancing coils 86A, retracting coils 86B and the stepper motor 82. The switches 44A, B, and C are all under the control of the controller 42. A memory 100 is connected to the controller. A set of instructions is stored in the memory 100 and is readable by the controller 42. Further functioning of the controller 42 in combination with the terminal 76 and the switches 44A, B, and C should be evident from the foregoing description.

[0078] Figure 11 illustrates a configuration for another embodiment of a cartridge having penetrating members. The cartridge 112 has a corrugated configuration and a plurality of penetrating members 118 in grooves 124 formed in opposing sides of the cartridge 112. Sterilization barriers 126 and 128 are attached over the penetrating members 118 at the top and the penetrating members 118 at the bottom, respectively. Such an arrangement provides large surfaces for attachment of the sterilization barriers 126 and 128. All the penetrating members 118 on the one side are used first, whereafter the cartridge 112 is turned over and the penetrating members 118 on the other side are used. Additional aspects of such a cartridge are also discussed in Figures 42-44.

[0079] Referring now to Figures 12-13, a friction based method of coupling with and driving bare lancets or bare penetrating members will be described in further detail. Any embodiment disclosed herein may be adapted to use these methods. As seen in Figure 12, surface 201 is physically in contact with penetrating member 202. Surface 203 is also physically in contact with penetrating member 202. In the present embodiment, surface 201 is stainless steel, penetrating member 202 is stainless steel, and surface 203 is polytetrafluoroethylene-coated stainless steel.

[0080] Figure 13 illustrates one embodiment of the friction based coupling in use. Normal force 206 may be applied vertically to surface 201, pressing it against penetrating member 202. Penetrating member 202 is thereby pressed against surface 203. Normal force 206 is transmitted through surface 201 and penetrating member 202 to also act between penetrating member 202 and surface

203. Surface 203 is held rigid or stationary with respect to a target of the lancet. Using the classical static friction model, the maximum frictional force between surface 201 and penetrating member 202 is equal to the friction coefficient between surface 201 and penetrating member 202 multiplied by the normal force between surface 201 and penetrating member 202. In this embodiment, the maximum frictional force between surface 203 and penetrating member 202 is equal to the coefficient of friction between the surface 203 and the penetrating member 202 multiplied by the normal force between the surface 203 and the penetrating member 202. Because friction coefficient between surface 203 and penetrating member 202 is less than friction coefficient between surface 201 and penetrating member 202, the interface between surface 201 and penetrating member 202 can develop a higher maximum static friction force than can the interface between surface 203 and penetrating member 202.

[0081] Driving force as indicated by arrow 207 is applied to surface 201 perpendicular to normal force 206. The sum of the forces acting horizontally on surface 201 is the sum of driving force 207 and the friction force developed at the interface of surface 201 and penetrating member 202, which acts in opposition to driving force 207. Since the coefficient of friction between surface 203 and penetrating member 202 is less than the coefficient of friction between surface 201 and penetrating member 202, penetrating member 202 and surface 201 will remain stationary with respect to each other and can be considered to behave as one piece when driving force 207 just exceeds the maximum frictional force that can be supported by the interface between surface 203 and penetrating member 202. Surface 201 and penetrating member 202 can be considered one piece because the coefficient of friction between surface 201 and penetrating member 202 is high enough to prevent relative motion between the two.

[0082] In one embodiment, the coefficient of friction between surface 201 and penetrating member 202 is approximately 0.8 corresponding to the coefficient of friction between two surfaces of stainless steel, while the coefficient of friction between surface 203 and penetrating member 202 is approximately 0.04, corresponding to the coefficient of friction between a surface of stainless steel and one of polytetrafluoroethylene. Normal force 206 has a value of 202 Newtons. Using these values, the maximum frictional force that the interface between surface 201 and penetrating member 202 can support is 1.6 Newtons, while the maximum frictional force that the interface between surface 203 and penetrating member 202 can support is 0.08 Newtons. If driving force 207 exceeds 0.08 Newtons, surface 201 and penetrating member 202 will begin to accelerate together with respect to surface 203. Likewise, if driving force 207 exceeds 1.6 Newtons and penetrating member 202 encounters a rigid barrier, surface 201 would move relative to penetrating member 202.

[0083] Another condition, for example, for surface 201

to move relative to penetrating member 202 would be in the case of extreme acceleration. In an embodiment, penetrating member 202 has a mass of 8.24×10^{-6} kg. An acceleration of 194,174 m/s² of penetrating member 202 would therefore be required to exceed the frictional force between penetrating member 202 and surface 201, corresponding to approximately 19,800 g's. Without being bound to any particular embodiment or theory of operation, other methods of applying friction base coupling may also be used. For example, the penetrating member 202 may be engaged by a coupler using an interference fit to create the frictional engagement with the member.

[0084] Figure 14 illustrates a polytetrafluoroethylene coating on stainless steel surface 203 in detail. It should be understood that the surface 203 may be coated with other materials such as but not limited to Teflon®, silicon, polymer or glass. The coating may cover all of the penetrating member, only the proximal portions, only the distal portions, only the tip, only some other portion, or some combination of some or all of the above. Figure 15 illustrates a doping of lead applied to surface 201, which conforms to penetrating member 202 microscopically when pressed against it. Both of these embodiments and other coated embodiments of a penetrating member may be used with the actuation methods described herein.

[0085] The shapes and configurations of surface 201 and surface 102 could be some form other than shown in Figures 12-15. For example, surface 201 could be the surface of a wheel, which when rotated causes penetrating member 202 to advance or retract relative to surface 203. Surface 201 could be coated with another conformable material besides lead, such as a plastic. It could also be coated with particles, such as diamond dust, or given a surface texture to enhance the friction coefficient of surface 201 with penetrating member 202. Surface 202 could be made of or coated with diamond, fluorinated ethylene propylene, perfluoroalkoxy, a copolymer of ethylene and tetrafluoroethylene, a copolymer of ethylene and chlorotrifluoroethylene, or any other material with a coefficient of friction with penetrating member 202 lower than that of the material used for surface 201.

[0086] Referring to Figure 16, a portion of a base plate 210 of an embodiment of a penetrating member cartridge is shown with a plurality of penetrating member slots 212 disposed in a radial direction cut into a top surface 214 of the base plate. A drive member 216 is shown with a distal edge 218 disposed within one of the penetrating member slots 212 of the base plate 210. The distal edge 218 of the drive member 216 is configured to slide within the penetrating member slots 212 with a minimum of friction but with a close fit to minimize lateral movement during a lancing cycle.

[0087] Figure 17 shows a distal portion 220 of a coated penetrating member 222 in partial longitudinal section. The coated penetrating member 222 has a core portion 224, a coating 226 and a tapered distal end portion 228. A portion of a coated drive member 230 is shown having a coating 234 with penetrating member contact surface

236. The penetrating member contact surface 236 forms an interface 238 with an outer surface 240 of the coated penetrating member 222. The interface 238 has a characteristic friction coefficient that will depend in part on the choice of materials for the penetrating member coating 226 and the drive member coating 234. If silver is used as the penetrating member and drive member coating 226 and 236, this yields a friction coefficient of about 1.3 to about 1.5. Other materials can be used for coatings 226 and 236 to achieve the desired friction coefficient. For example, gold, platinum, stainless steel and other materials may be used for coatings 226 and 236. It may be desirable to use combinations of different materials for coatings 226 and 236. For example, an embodiment may include silver for a penetrating member coating 226 and gold for a drive member coating. Some embodiments of the interface 238 can have friction coefficients of about 1.15 to about 5.0, specifically, about 1.3 to about 2.0.

[0088] Embodiments of the penetrating member 222 can have an outer transverse dimension or diameter of about 200 to about 400 microns, specifically, about 275 to about 325 microns. Embodiments of penetrating member 222 can have a length of about 10 to about 30 millimeters, specifically, about 15 to about 25 millimeters. Penetrating member 222 can be made from any suitable high strength alloy such as stainless steel or the like.

[0089] Figure 18 is a perspective view of a lancing device 242. A penetrating member cartridge 244 is disposed about a driver 246 that is coupled to a drive member 248 by a coupler rod 250. The penetrating member cartridge 244 has a plurality of penetrating member slots 252 disposed in a radial configuration in a top surface 254 a base plate 256 of the penetrating member cartridge 244. The distal ends 253 of the penetrating member slots 252 are disposed at an outer surface 260 of the base plate 256. A fractureable sterility barrier 258, shown partially cut away, is disposed on the top surface 254 of base plate 256 over the plurality of penetrating member slots 252. The sterility barrier 258 is also disposed over the outer surface 260 of the base plate 256 in order to seal the penetrating member slots from contamination prior to a lancing cycle. A distal portion of a penetrating member 262 is shown extending radially from the penetrating member cartridge 244 in the direction of a patient's finger 264.

[0090] Figure 19 illustrates a portion of the base plate 256 used with the lancing device 242 in more detail and without sterility barrier 258 in place (for ease of illustration). The base plate 256 includes a plurality of penetrating member slots 252 which are in radial alignment with corresponding drive member slots 266. The drive member slots 266 have an optional tapered input configuration that may facilitate alignment of the drive member 248 during downward movement into the drive member slot 266 and penetrating member slot 252. Penetrating member slots 252 are sized and configured to accept a penetrating member 262 disposed therein and allow axial movement of the penetrating member 262 within the pen-

etrating member slots 252 without substantial lateral movement.

[0091] Referring again to Figure 18, in use, the present embodiment of penetrating member cartridge 242 is placed in an operational configuration with the driver 246. A lancing cycle is initiated and the drive member 248 is brought down through the sterility barrier 258 and into a penetrating member slot 252. A penetrating member contact surface of the drive member then makes contact with an outside surface of the penetrating member 262 and is driven distally toward the patient's finger 264 as described above with regard to the embodiment discussed in Figure 20. The friction coefficient between the penetrating member contact surface of the drive member 248 and the penetrating member 262 is greater than the friction coefficient between the penetrating member 262 and an interior surface of the penetrating member slots 252. As such, the drive member 248 is able to drive the penetrating member 262 distally through the sterility barrier 258 and into the patient's finger 264 without any relative movement or substantial relative movement between the drive member 248 and the penetrating member 262.

[0092] Referring to Figures 20-22, a lancing cycle sequence is shown for a lancing device 242 with another embodiment of a penetrating member cartridge 244 as shown in Figures 23 and 24. The base plate 256 of the penetrating member cartridge 242 shown in Figures 23 and 24 has a plurality of penetrating member slots 252 with top openings 268 that do not extend radially to the outer surface 260 of the base plate 256. In this way, the penetrating member slots 252 can be sealed with a first sterility barrier 270 disposed on the top surface 254 of the base plate 256 and a second sterility barrier 272 disposed on the outer surface 260 of the base plate 256. Penetrating member outlet ports 274 are disposed at the distal ends of the penetrating member slots 252.

[0093] Referring again to Figure 20, the penetrating member 262 is shown in the proximally retracted starting position within the penetrating member slot 252. The outer surface of the penetrating member 276 is in contact with the penetrating member contact surface 278 of the drive member 248. The friction coefficient between the penetrating member contact surface 278 of the drive member 248 and the outer surface 276 of the penetrating member 262 is greater than the friction coefficient between the penetrating member 262 and an interior surface 280 of the penetrating member slots 252. A distal drive force as indicated by arrow 282 in Figure 10 is then applied via the drive coupler 250 to the drive member 248 and the penetrating member is driven out of the penetrating member outlet port 274 and into the patient's finger 264. A proximal retraction force, as indicated by arrow 284 in Figure 22, is then applied to the drive member 248 and the penetrating member 262 is withdrawn from the patient's finger 264 and back into the penetrating member slot 252.

[0094] Figures 25 and 26 illustrate an embodiment of a multiple layer sterility barrier 258 in the process of being

penetrated by a penetrating member 62. It should be understood that this barrier 258 may be adapted for use with any embodiment disclosed. The sterility barrier 258 shown in Figures 25 and 26 is a two layer sterility barrier 258 that facilitates maintaining sterility of the penetrating member 262 as it passes through and exits the sterility barrier 258. In Figure 25, the distal end 286 of the penetrating member 262 is applying an axial force in a distal direction against an inside surface 288 of a first layer 290 of the sterility barrier 258, so as to deform the first layer 290 of the sterility barrier 258. The deformation 291 of the first layer 290 in turn applies a distorting force to the second layer 292 of the sterility barrier 258. The second layer of the sterility barrier is configured to have a lower tensile strength than the first layer 290. As such, the second layer 292 fails prior to the first layer 290 due to the strain imposed on the first layer 290 by the distal end 286 of the penetrating member 262, as shown in Figure 26. After the second layer 292 fails, it then retracts from the deformed portion 291 of the first layer 290 as shown by arrows 294 in Figure 26. As long as the inside surface 288 and outside surfaces 296 of the first layer 290 are sterile prior to failure of the second layer 292, the penetrating member 262 will remain sterile as it passes through the first layer 290 once the first layer eventually fails. Such a multiple layer sterility barrier 258 can be used for any of the embodiments discussed herein. The multiple layer sterility barrier 258 can also include three or more layers.

[0095] Referring to Figures 27 and 28, an embodiment of a drive member 300 coupled to a driver 302 wherein the drive member 300 includes a cutting member 304 having a sharpened edge 306 which is configured to cut through a sterility barrier 258 of a penetrating member slot 252 during a lancing cycle in order for the drive member 300 to make contact with a penetrating member. An optional lock pin 308 on the cutting member 304 can be configured to engage the top surface 310 of the base plate in order to prevent distal movement of the cutting member 304 with the drive member 300 during a lancing cycle.

[0096] Figures 29 and 30 illustrate an embodiment of a penetrating member slot 316 in longitudinal section having a ramped portion 318 disposed at a distal end 320 of the penetrating member slot. A drive member 322 is shown partially disposed within the penetrating member slot 316. The drive member 322 has a cutting edge 324 at a distal end 326 thereof for cutting through a sterility barrier 328 during a lancing cycle. Figure 30 illustrates the cutting edge 324 cutting through the sterility barrier 328 during a lancing cycle with the cut sterility barrier 328 peeling away from the cutting edge 324.

[0097] Figures 31-34 illustrate drive member slots in a base plate 330 of a penetrating member cartridge wherein at least a portion of the drive member slots have a tapered opening which is larger in transverse dimension at a top surface of the base plate than at the bottom of the drive member slot. Figure 31 illustrates a base plate

330 with a penetrating member slot 332 that is tapered at the input 334 at the top surface 336 of the base plate 330 along the entire length of the penetrating member slot 332. In such a configuration, the penetrating member slot and drive member slot (not shown) would be in communication and continuous along the entire length of the slot 332. As an optional alternative, a base plate 338 as shown in Figure 32 and 33 can have a drive member slot 340 that is axially separated from the corresponding penetrating member slot 342. With this configuration, the drive member slot 340 can have a tapered configuration and the penetrating member slot 342 can have a straight walled configuration. In addition, this configuration can be used for corrugated embodiments of base plates 346 as shown in Figure 34. In Figure 34, a drive member 348 is disposed within a drive member slot 350.

A penetrating member contact surface 352 is disposed on the drive member 348. The contact surface 352 has a tapered configuration that will facilitate lateral alignment of the drive member 348 with the drive member slot 350.

[0098] Figures 35-37 illustrate an embodiment of a penetrating member cartridge 360 and drive member 362 wherein the drive member 362 has contoured jaws 364 configured to grip a penetrating member shaft 366. In Figure 35, the drive member 362 and penetrating member shaft 366 are shown in transverse cross section with the contoured jaws 364 disposed about the penetrating member shaft 366. A pivot point 368 is disposed between the contoured jaws 364 and a tapered compression slot 370 in the drive member 362. A compression wedge 372 is shown disposed within the tapered compression slot 370. Insertion of the compression wedge 372 into the compression slot 370 as indicated by arrow 374, forces the contoured jaws 364 to close about and grip the penetrating member shaft 366 as indicated by arrows 376.

[0099] Figure 36 shows the drive member 362 in position about a penetrating member shaft 366 in a penetrating member slot 378 in the penetrating member cartridge 360. The drive member can be actuated by the methods discussed above with regard to other driven member and driver embodiments. Figure 37 is an elevational view in longitudinal section of the penetrating member shaft 166 disposed within the penetrating member slot 378. The arrows 380 and 382 indicate in a general way, the path followed by the drive member 362 during a lancing cycle. During a lancing cycle, the drive member comes down into the penetrating member slot 378 as indicated by arrow 380 through an optional sterility barrier (not shown). The contoured jaws of the drive member then clamp about the penetrating member shaft 366 and move forward in a distal direction so as to drive the penetrating member into the skin of a patient as indicated by arrow 382.

[0100] Figures 38 and 39 show a portion of a lancing device 390 having a lid 392 that can be opened to expose a penetrating member cartridge cavity 394 for removal of a used penetrating member cartridge 396 and insertion of a new penetrating member cartridge 398. Depression

of button 400 in the direction indicated by arrow 402 raises the drive member 404 from the surface of the penetrating member cartridge 396 by virtue of lever action about pivot point 406. Raising the lid 392 actuates the lever arm 408 in the direction indicated by arrow 410 which in turn applies a tensile force to cable 412 in the direction indicated by arrow 414. This action pulls the drive member back away from the penetrating member cartridge 396 so that the penetrating member cartridge 396 can be removed from the lancing device 390. A new penetrating member cartridge 398 can then be inserted into the lancing device 390 and the steps above reversed in order to position the drive member 404 above the penetrating member cartridge 398 in an operational position.

[0101] Figures 40 and 41 illustrate a penetrating member cartridge 420 that has penetrating member slots 422 on a top side 424 and a bottom side 426 of the penetrating member cartridge 420. This allows for a penetrating member cartridge 420 of a diameter D to store for use twice the number of penetrating members as a one sided penetrating member cartridge of the same diameter D.

[0102] Figures 42-44 illustrate end and perspective views of a penetrating member cartridge 430 having a plurality of penetrating member slots 432 formed from a corrugated surface 434 of the penetrating member cartridge 430. Penetrating members 436 are disposed on both sides of the penetrating member cartridge 430. A sterility barrier 438 is shown disposed over the penetrating member slots 432 in Figure 44.

[0103] Figures 45-48 illustrate embodiments of a penetrating member 440 and drive member 442 wherein the penetrating member 440 has a transverse slot 444 in the penetrating member shaft 446 and the drive member 442 has a protuberance 448 configured to mate with the transverse slot 444 in the penetrating member shaft 446. Figure 45 shows a protuberance 448 having a tapered configuration that matches a tapered configuration of the transverse slot 444 in the penetrating member shaft 446. Figure 46 illustrates an optional alternative embodiment wherein the protuberance 448 has straight walled sides that are configured to match the straight walled sides of the transverse slot 444 shown in Figure 46. Figure 47 shows a tapered protuberance 448 that is configured to leave an end gap 450 between an end of the protuberance 448 and a bottom of the transverse slot in the penetrating member shaft 446.

[0104] Figure 48 illustrates a mechanism 452 to lock the drive member 442 to the penetrating member shaft 446 that has a lever arm 454 with an optional bearing 456 on the first end 458 thereof disposed within a guide slot 459 of the drive member 442. The lever arm 454 has a pivot point 460 disposed between the first end 458 of the lever arm 454 and the second end 462 of the lever arm 454. A biasing force is disposed on the second end 462 of the lever arm 454 by a spring member 464 that is disposed between the second end 462 of the lever arm 454 and a base plate 466. The biasing force in the direction indicated by arrow 468 forces the penetrating mem-

ber contact surface 470 of the drive member 442 against the outside surface of the penetrating member 446 and, in addition, forces the protuberance 448 of the drive member 442 into the transverse slot 444 of the penetrating member shaft 446.

[0105] Referring now to Figure 49, another embodiment of a replaceable cartridge 500 suitable for housing a plurality of individually moveable penetrating members (not shown) will be described in further detail. Although cartridge 500 is shown with a chamfered outer periphery, it should also be understood that less chamfered and unchamfered embodiments of the cartridge 500 may also be adapted for use with any embodiment disclosed herein. The penetrating members slidably coupled to the cartridge may be a bare lancet or bare elongate member without outer molded part or body pieces as seen in conventional lancet. The bare design reduces cost and simplifies manufacturing of penetrating members for use with the present invention. The penetrating members may be retractable and held within the cartridge so that they are not able to be used again. The cartridge is replaceable with a new cartridge once all the piercing members have been used. The lancets or penetrating members may be fully contained in the used cartridge so as to minimize the chance of patient contact with such waste.

[0106] As can be seen in Figure 49, the cartridge 500 may include a plurality of cavities 501 for housing a penetrating member. In this embodiment, the cavity 501 may have a longitudinal opening 502 associated with the cavity. The cavity 501 may also have a lateral opening 503 allowing the penetrating member to exit radially outward from the cartridge. As seen in Figure 49, the outer radial portion of the cavity may be narrowed. The upper portion of this narrowed area may also be sealed or swaged to close the top portion 505 and define an enclosed opening 506 as shown in Figure 50. Optionally, the narrowed area 504 may retain an open top configuration, though in some embodiments, the foil over the gap is unbroken, preventing the penetrating member from lifting up or extending upward out of the cartridge. The narrowed portion 504 may act as a bearing and/or guide for the penetrating member. Figure 51 shows that the opening 506 may have a variety of shapes such as but not limited to, circular, rectangular, triangular, hexagonal, square, or combinations of any or all of the previous shapes. Openings 507 (shown in phantom) for other microfluidics, capillary tubes, or the like may also be incorporated in the immediate vicinity of the opening 506. In some optional embodiments, such openings 507 may be configured to surround the opening 506 in a concentric or other manner.

[0107] Referring now to Figure 52, the underside of a cartridge 500 will be described in further detail. This figure shows many features on one cartridge 500. It should be understood that a cartridge may include some, none, or all of these features, but they are shown in Figure 52 for ease of illustration. The underside may include indentations or holes 510 close to the inner periphery for purpose of properly positioning the cartridge to engage a

penetrating member gripper and/or to allow an advancing device (shown in Figure 56B and 56C) to rotate the cartridge 500. Indentations or holes 511 may be formed along various locations on the underside of cartridge 500 and may assume various shapes such as but not limited to, circular, rectangular, triangular, hexagonal, square, or combinations of any or all of the previous shapes. Notches 512 may also be formed along the inner surface of the cartridge 500 to assist in alignment and/or rotation of the cartridge. It should be understood of course that some of these features may also be placed on the top side of the cartridge in areas not occupied by cavities 501 that house the penetrating members. Notches 513 may also be incorporated along the outer periphery of the cartridge. These notches 513 may be used to gather excess material from the sterility barrier 28 (not shown) that may be used to cover the angled portion 514 of the cartridge. In the present embodiment, the cartridge has a flat top surface and an angled surface around the outside. Welding a foil type sterility barrier over that angled surface, the foil folds because of the change in the surfaces which is now at 45 degrees. This creates excess material. The grooves or notches 513 are there as a location for that excess material. Placing the foil down into those grooves 513 which may tightly stretch the material across the 45 degree angled surface. Although in this embodiment the surface is shown to be at 45 degrees, it should be understood that other angles may also be used. For example, the surface may be at any angle between about 3 degrees to 90 degrees, relative to horizontal. The surface may be squared off. The surface may be unchamfered. The surface may also be a curved surface or it may be combinations of a variety of angled surfaces, curved and straight surfaces, or any combination of some or all of the above.

[0108] Referring now to Figures 53-54, the sequence in which the cartridge 500 is indexed and penetrating members are actuated will now be described. It should be understood that some steps described herein may be combined or taken out of order. These sequence of steps provides vertical and horizontal movement used with the present embodiment to load a penetrating member onto the driver.

[0109] As previously discussed, each cavity on the cartridge may be individually sealed with a foil cover or other sterile enclosure material to maintain sterility until or just before the time of use. In the present embodiment, penetrating members are released from their sterile environments just prior to actuation and are loaded onto a launcher mechanism for use. Releasing the penetrating member from the sterile environment prior to launch allows the penetrating member in the present embodiment to be actuated without having to pierce any sterile enclosure material which may dull the tip of the penetrating member or place contaminants on the member as it travels towards a target tissue. A variety of methods may be used accomplish this goal.

[0110] Figure 53A shows one embodiment of pene-

trating member release device, which in this embodiment is a punch plate 520 that is shown in a see-through depiction for ease of illustration. The punch plate 520 may include a first portion 521 for piercing sterile material covering the longitudinal opening 502 and a second portion 522 for piercing material covering the lateral opening 503. A slot 523 allows the penetrating member gripper to pass through the punch plate 520 and engage a penetrating member housed in the cartridge 500. The second portion 522 of the punch plate down to engage sterility barrier angled at about a 45 degree slope. Of course, the slope of the barrier may be varied. The punch portion 522 first contacts the rear of the front pocket sterility barrier and as it goes down, the cracks runs down each side and the barrier is pressed down to the bottom of the front cavity. The rear edge of the barrier first contacted by the punch portion 522 is broken off and the barrier is pressed down, substantially cleared out of the way. These features may be more clearly seen in Figure 53B. The punch portion 521 may include a blade portion down the centerline. As the punch comes down, that blade may be aligned with the center of the cavity, cutting the sterility barrier into two pieces. The wider part of the punch 521 then pushes down on the barrier so the they align parallel to the sides of the cavity. This creates a complete and clear path for the gripper throughout the longitudinal opening of the cavity. Additionally, as seen in Figure 53B and 54A, a plurality of protrusion 524 are positioned to engage a cam (Figure 55A) which sequences the punching and other vertical movement of punch plate 520 and cartridge pusher 525. The drive shaft 526 from a force generator (not shown) which is used to actuate the penetrating member 527.

[0111] Referring now to Figures 54A-F, the release and loading of the penetrating members are achieved in the following sequence. Figure 54A shows the release and loading mechanism in rest state with a dirty bare penetrating member 527 held in a penetrating member gripper 530. This is the condition of the device between lancing events. When the time comes for the patient to initiate another lancing event, the used penetrating member is cleared and a new penetrating member is loaded, just prior to the actual lancing event. The patient begins the loading of a new penetrating member by operating a setting lever to initiate the process. The setting lever may operate mechanically to rotate a cam (see Figure 55A) that moves the punch plate 520 and cartridge pusher 525. In other embodiments, a stepper motor or other mover such as but not limited to, a pneumatic actuator, hydraulic actuator, or the like are used to drive the loading sequence.

[0112] Figure 54B shows one embodiment of penetrating member gripper 530 in more detail. The penetrating member gripper 530 may be in the form of a tuning fork with sharp edges along the inside of the legs contacting the penetrating member. In some embodiments, the penetrating member may be notched, recessed, or otherwise shaped to receive the penetrating member

gripper. As the gripper 530 is pushed down on the penetrating member, the legs are spread open elastically to create a frictional grip with the penetrating member such as but not limited to bare elongate wires without attachments molded or otherwise attached thereon. In some embodiments, the penetrating member is made of a homogenous material without any additional attachments that are molded, adhered, glued or otherwise added onto the penetrating member.

[0113] In some embodiments, the gripper 530 may cut into the sides of the penetrating member. The penetrating member in one embodiment may be about 300 microns wide. The grooves that form in the side of the penetrating member by the knife edges are on the order of about 5-10 microns deep and are quite small. In this particular embodiment, the knife edges allow the apparatus to use a small insertion force to get the gripper onto the penetrating member, compared to the force to remove the penetrating member from the gripper the longitudinal axis of an elongate penetrating member. Thus, the risk of a penetrating member being detached during actuation are reduced. The gripper 530 may be made of a variety of materials such as, but not limited to high strength carbon steel that is heat treated to increased hardness, ceramic, substrates with diamond coating, composite reinforced plastic, elastomer, polymer, and sintered metals. Additionally, the steel may be surface treated. The gripper 130 may have high gripping force with low friction drag on solenoid or other driver.

[0114] As seen in Figure 54C, the sequence begins with punch plate 520 being pushed down. This results in the opening of the next sterile cavity 532. In some embodiment, this movement of punch plate 520 may also result in the crimping of the dirty penetrating member to prevent it from being used again. This crimping may result from a protrusion on the punch plate bending the penetrating member or pushing the penetrating member into a groove in the cartridge that hold the penetrating member in place through an interference fit. As seen in Figures 53B and 54C, the punch plate 520 has a protrusion or punch shaped to penetrate a longitudinal opening 502 and a lateral opening 503 on the cartridge. The first portion 521 of the punch that opens cavity 532 is shaped to first pierce the sterility barrier and then push, compresses, or otherwise moves sterile enclosure material towards the sides of the longitudinal opening 502. The second portion 522 of the punch pushes down the sterility barrier at lateral opening or penetrating member exit 503 such that the penetrating member does not pierce any materials when it is actuated toward a tissue site.

[0115] Referring now to Figure 54D, the cartridge pusher 525 is engaged by the cam 550 (not shown) and begins to push down on the cartridge 500. The punch plate 520 may also travel downward with the cartridge 500 until it is pushed down to its maximum downward position, while the penetrating member gripper 530 remains vertically stationary. This joint downward motion away from the penetrating member gripper 530 will remove the

penetrating member from the gripper. The punch plate 520 essentially pushes against the penetrating member with protrusion 534 (Figure 55A), holding the penetrating member with the cartridge, while the cartridge 500 and the punch plate 520 is lowered away from the penetrating member gripper 530 which in this embodiment remains vertically stationary. This causes the stripping of the used penetrating member from the gripper 530 (Figure 45D) as the cartridge moves relative to the gripper.

[0116] At this point as seen in Figure 54E, the punch plate 520 retracts upward and the cartridge 500 is pushed fully down, clear of the gripper 530. Now cleared of obstructions and in a rotatable position, the cartridge 500 increments one pocket or cavity in the direction that brings the newly released, sterile penetrating member in cavity 532 into alignment with the penetrating member gripper 530, as seen in Figure 54F. The rotation of the cartridge occurs due to fingers engaging the holes or indentations 533 on the cartridge, as seen in Figure 54A. In some embodiments, these indentations 533 do not pass completely through cartridge 500. In other embodiments, these indentations are holes passing completely through. The cartridge has a plurality of little indentations 533 on the top surface near the center of the cartridge, along the inside diameter. In the one embodiment, the sterility barrier is cut short so as not to cover these plurality of indentations 533. It should be understood of course that these holes may be located on bottom, side or other accessible surface. These indentations 533 have two purposes. The apparatus may have one or a plurality of locator pins, static pins, or other keying feature that does not move. In this embodiment, the cartridge will only set down into positions where the gripper 530 is gripping the penetrating member. To index the cassette, the cartridge is lifted off those pins or other keyed feature, rotated around, and dropped onto those pins for the next position. The rotating device is through the use of two fingers: one is a static pawl and the other one is a sliding finger. They engage with the holes 533. The fingers are driven by a slider that may be automatically actuated or actuated by the user. This may occur mechanically or through electric or other powered devices. Halfway through the stroke, a finger may engage and rotate around the cartridge. A more complete description can be found with text associated with Figures 56B-56C.

[0117] Referring now to Figure 54G, with the sterile penetrating member in alignment, the cartridge 500 is released as indicated by arrows 540 and brought back into contact with the penetrating member gripper 530. The new penetrating member 541 is inserted into the gripper 530, and the apparatus is ready to fire once again. After launch and in between lancing events for the present embodiment, the bare lancet or penetrating member 541 is held in place by gripper 530, preventing the penetrating member from accidentally protruding or sliding out of the cartridge 500.

[0118] It should be understood of course, that variations can be added to the above embodiment. For exam-

ple, the penetrating member 541 may be placed in a parked position in the cartridge 500 prior to launch. As seen in Figure 55A, the penetrating member is held by a narrowed portion 542 of the cartridge, creating an interference fit which pinches the proximal end of the penetrating member. Friction from the molding or cartridge holds the penetrating member during rest, preventing the penetrating member from sliding back and forth. Of course, other methods of holding the penetrating member may also be used. As seen in Figure 55B prior to launch, the penetrating member gripper 530 may pull the penetrating member 541 out of the portion 542. The penetrating member 541 may remain in this portion until actuated by the solenoid or other force generator coupled to the penetrating member gripper. A cam surface 544 may be used to pull the penetrating member out of the portion 542. This mechanical cam surface may be coupled to the mechanical slider driven by the patient, which may be considered a separate force generator. Thus, energy from the patient extracts the penetrating member and this reduces the drain on the device's battery if the solenoid or electric driver were to pull out the penetrating member. The penetrating member may be moved forward a small distance (on the order of about 1 mm or less) from its parked position to pull the penetrating member from the rest position gripper. After penetrating tissue, the penetrating member may be returned to the cartridge and eventually placed into the parked position. This may also occur, though not necessarily, through force provided by the patient. In one embodiment, the placing of the lancet into the parked position does not occur until the process for loading a new penetrating member is initiated by the patient. In other embodiments, the pulling out of the parked position occurs in the same motion as the penetrating member actuation. The return into the parked position may also be considered a continuous motion.

[0119] Figure 55A also shows one embodiment of the cam and other surfaces used to coordinate the motion of the punch plate 520. For example, cam 550 in this embodiment is circular and engages the protrusions 524 on the punch plate 520 and the cartridge pusher 525. Figure 55A also more clearly shows protrusion 534 which helps to hold the penetrating member in the cartridge 500 while the penetrating member gripper 530 pulls away from the member, relatively speaking. A ratchet surface 552 that rotates with the cam 550 may be used to prevent the cam from rotating backwards. The raising and lowering of cartridge 500 and punch plate 50 used to load/unload penetrating members may be mechanically actuated by a variety of cam surfaces, springs, or the like as may be determined by one skilled in the art. Some embodiments may also use electrical or magnetic device to perform the loading, unloading, and release of bare penetrating members. Although the punch plate 520 is shown to be punching downward to displace, remove, or move the foil or other sterile environment enclosure, it should be understood that other methods such as stripping, pulling,

tearing, or some combination of one or more of these methods may be used to remove the foil or sterile enclosure. For example, in other embodiments, the punch plate 520 may be located on an underside of the cartridge and punch upward. In other embodiments, the cartridge may remain vertically stationary while other parts such as the penetrating member gripper and punch plate move to load a sterile penetrating member on to the penetrating member gripper.

[0120] Figure 55B also shows other features that may be included in the present apparatus. A fire button 560 may be included for the user to actuate the penetrating member. A front end interface 561 may be included to allow a patient to seat their finger or other target tissue for lancing. The interface 561 may be removable to be cleaned or replaced. A visual display 562 may be included to show device status, lancing performance, error reports, or the like to the patient.

[0121] Referring now to Figure 56A, a mechanical slider 564 used by the patient to load new penetrating member may also be incorporated on the housing. The slider 564 may also be coupled to activate an LCD or visual display on the lancing apparatus. In addition to providing a source of energy to index the cartridge, the slider 564 may also switch the electronics to start the display. The user may use the display to select the depth of lancing or other feature. The display may go back to sleep again until it is activated again by motion of the slider 564. The underside the housing 566 may also be hinged or otherwise removable to allow the insertion of cartridge 500 into the device. The cartridge 500 may be inserted using technology current used for insertion of a compact disc or other disc into a compact disc player. In one embodiment, there may be a tray which is deployed outward to receive or to remove a cartridge. The tray may be withdrawn into the apparatus where it may be elevated, lowered, or otherwise transported into position for use with the penetrating member driver. In other embodiments, the apparatus may have a slot into which the cartridge is partially inserted at which point a mechanical apparatus will assist in completing insertion of the cartridge and load the cartridge into proper position inside the apparatus. Such device is akin to the type of compact disc player found on automobiles. The insertions/ejection and loading apparatus of these compact disc players uses gears, pulleys, cables, trays, and/or other parts that may be adapted for use with the present invention.

[0122] Referring now to Figure 56B, a more detailed view of one embodiment of the slider 564 is provided. In this embodiment, the slider 564 will move initially as indicated by arrow 567. To complete the cycle, the patient will return the slider to its home position or original starting position as indicated by arrow 568. The slider 564 has an arm 569 which moves with the slider to rotate the cam 550 and engage portions 522. The motion of the slider 564 is also mechanically coupled to a finger 570 which engage the indentations 571 on cartridge 500. The finger 570 is synchronized to rotate the cartridge 500 by pulling

as indicated by arrow 572 in the same plane as the cartridge. It should be understood that in some embodiments, the finger 570 pushes instead of pulls to rotate the cartridge in the correct direction. The finger 570 may also be adapted to engage ratchet surfaces 706 as seen in Figure 66 to rotate a cartridge. The finger 570 may also incorporate vertical motion to coordinate with the rising and lowering of the cartridge 500. The motion of finger 570 may also be powered by electric actuators such as a stepper motor or other device useful for achieving motion. Figure 56B also shows a portion of the encoder 573 used in position sensing.

[0123] Referring now to Figure 56C, a still further view of the slider 564 and arm 569 is shown. The arm 569 moves to engage portion 522 as indicated by arrow 575 and this causes the cam 550 to rotate as indicated by arrow 577. In this particular embodiment, the cam 550 rotates about 1/8 of a rotation with each pull of the slider 564. When the slider 564 is return to its home or start position, the arm 569 rides over the portion 522. The movement of the slider also allows the cam surface 544 to rotate about pivot point 579. A resilient member 580 may be coupled to the cam surface 544 to cause it to rotate counterclockwise when the arm 569 moves in the direction of arrow 567. The pin 580 will remain in contact with the arm 569. As the cam surface 544 rotates a first surface 582 will contact the pin 583 on the gripper block 584 and pull the pin 583 back to park a penetrating member into a coupling or narrowed portion 542 of the cartridge 500 as seen in Figure 55A. As the arm 569 is brought back to the home position, the cam surface 544 rotates back and a second surface 586 that rotates clockwise and pushes the penetrating member forward to be released from the narrowed portion 542 resulting in a position as seen in Figure 55B. It should be understood that in some embodiments, the release and/or parking of lancet from portion 542 may be powered by the driver 588 without using the mechanical assistance from cam surface 544.

[0124] In another embodiment of the cartridge device, a mechanical feature may be included on the cartridge so that there is only one way to load it into the apparatus. For example, in one embodiment holding 50 penetrating members, the cartridge may have 51 pockets or cavities. The S1st pocket will go into the firing position when the device is loaded, thus providing a location for the gripper to rest in the cartridge without releasing a penetrating member from a sterile environment. The gripper 530 in that zeroth position is inside the pocket or cavity and that is the reason why one of the pockets may be empty. Of course, some embodiments may have the gripper 530 positioned to grip a penetrating member as the cartridge 500 is loaded into the device, with the patient lancing themselves soon afterwards so that the penetrating member is not contaminated due to prolonged exposure outside the sterile enclosure. That zeroth position may be the start and finish position. The cartridge may also be notched to engaged a protrusion on the apparatus,

thus also providing a method for allowing the penetrating member to loaded or unloaded only in one orientation. Essentially, the cartridge 500 may be keyed or slotted in association with the apparatus so that the cartridge 500 can only be inserted or removed at one orientation. For example as seen in Figure 56D, the cartridge 592 may have a keyed slot 593 that matches the outline of a protrusion 594 such that the cartridge 592 may only be removed upon alignment of the slot 593 and protrusion 594 upon at the start or end positions. It should be understood that other keyed technology may be used and the slot or key may be located on an outer periphery or other location on the cartridge 592 in manner useful for allowing insertion or removal of the cartridge from only one or a select number of orientations.

[0125] Referring now to Figure 57, a cross-section of another embodiment of a cavity 600 housing a penetrating member is shown. The cavity 600 may include a depression 602 for allowing the gripper 530 to penetrate sufficiently deeply into the cavity to frictionally engage the penetrating member 541. The penetrating member may also be housed in a groove 604 that holds the penetrating member in place prior to and after actuation. The penetrating member 541 is lifted upward to clear the groove 604 during actuation and exits through opening 506.

[0126] Referring now to Figure 58, another variation on the system disclosed will now be described. Figure 58 shows a lancing system 610 wherein the penetrating members have their sharpened tip pointed radially inward. The finger or other tissue of the patient is inserted through the center hole 611 to be pierced by the member 612. The penetrating member gripper 530 coupled to drive force generator 613 operate in substantially the same manner as described in Figures 54A-G. The punch portions 521 and 522 operate in substantially the same manner to release the penetrating members from the sterile enclosures. The punch portion 522 may be placed on the inner periphery of the device, where the penetrating member exit is now located, so that sterile enclosure material is cleared out of the path of the penetrating member exit.

[0127] Referring now to Figure 59, a still further variation on the lancing system will now be described. In the embodiments shown in Figures 53-54, the penetrating member gripper 530 approaches the penetrating member from above and at least a portion of the drive system is located in a different plane from that of the cartridge 500. Figure 59 shows an embodiment where the penetrating member driver 620 is in substantially the same plane as the penetrating member 622. The coupler 624 engages a bent or L shaped portion 626 of the member 622. The cartridge 628 can rotate to engage a new penetrating member with the coupler 624 without having to move the cartridge or coupler vertically. The next penetrating member rotates into position in the slot provided by the coupler 624. A narrowed portion of the cartridge acts as a penetrating member guide 630 near the distal

end of the penetrating member to align the penetrating member as it exits the cartridge.

[0128] The coupler 624 may come in a variety of configurations. For example, Figure 60A shows a coupler 632 which can engage a penetrating member 633 that does not have a bent or L-shaped portion. A radial cartridge carrying such a penetrating member 633 may rotate to slide penetrating member into the groove 634 of the coupler 632. Figure 60B is a front view showing that the coupler 632 may include a tapered portion 636 to guide the penetrating member 633 into the slot 634. Figure 60C shows an embodiment of the driver 620 using a coupler 637 having a slot 638 for receiving a T-shaped penetrating member. The coupler 637 may further include a protrusion 639 that may be guided in an overhead slot to maintain alignment of the drive shaft during actuation.

[0129] Referring now to Figure 61, a cartridge 640 for use with an in-plane driver 620 is shown. The cartridge 640 includes an empty slot 642 that allows the cartridge to be placed in position with the driver 620. In this embodiment, the empty slot 642 allows the coupler 644 to be positioned to engage an unused penetrating member 645 that may be rotated into position as shown by arrow 646. As seen in Figure 61, the cartridge 640 may also be designed so that only the portion of the penetrating member that needs to remain sterile (i.e. the portions that may actually be penetrating into tissue) are enclosed. As seen in Figure 61, a proximal portion 647 of the penetrating member is exposed. This exposed proximal portion may be about 70% of the penetrating member. In other embodiments it may be between about 69% to about 5% of the penetrating member. The cartridge 640 may further include, but not necessarily, sealing protrusions 648. These protrusions 648 are releasably coupled to the cartridge 640 and are removed from the cartridge 640 by remover 649 as the cartridge rotates to place penetrating member 645 into the position of the active penetrating member. The sterile environment is broken prior to actuation of the member 645 and the member does not penetrate sterile enclosure material that may dull the tip of the penetrating member during actuation. A fractureable seal material 650 may be applied to the member to seal against an inner peripheral portion of the cartridge.

[0130] Referring now to Figure 62, a still further embodiment of a cartridge for use with the present invention will be described. This cartridge 652 includes a tapered portion 654 for allowing the coupler 655 to enter the cavity 656. A narrowed portion 657 guides the penetrating member 658. The coupler 655 may have, but does not necessarily have, movable jaws 659 that engage to grip the penetrating member 658. Allowing the coupler to enter the cavity 656 allows the alignment of the penetrating member to be better maintained during actuation. This tapered portion 654 may be adapted for use with any embodiment of the cartridge disclosed herein.

[0131] Referring now to Figure 63, a linear cartridge 660 will be described. Figures 79-83 show other cartridge

es of varying shapes adaptable for use with the present invention. Figure 63 illustrates a cartridge 660 with only a portion 662 providing sterile protection for the penetrating members. The cartridge 660, however, provides a base 664 on which a penetrating member 665 can rest. This provides a level of protection of the penetrating member during handling. The base 664 may also be shaped to provide slots 666 in which a penetrating member 667 may be held. The slot 666 may also be adapted to have a tapered portion 668. These configurations may be adapted for use with any of the embodiments disclosed herein, such as the cartridge 652.

[0132] Referring now to Figures 64A-64C, a variety of different devices are shown for releasing the sterility seal covering a lateral opening 503 on the cartridge 500. Figure 64A shows a rotating punch device 670 that has protrusions 672 that punch out the sterility barrier creating openings 674 from which a penetrating member can exit without touching the sterility barrier material. Figure 64B shows a vertically rotating device 676 with shaped protrusions 678 that punch down the sterility barrier 679 as it is rotated to be in the active, firing position. Figure 64C shows a punch 680 which is positioned to punch out barrier 682 when the cartridge is lowered onto the punch. The cartridge is rotated and the punch 680 rotates with the cartridge. After the cartridge is rotated to the proper position and lifted up, the punch 680 is spring loaded or otherwise configured to return to the position to engage the sterility barrier covering the next unused penetrating member.

[0133] Referring now to Figure 65A-65B, another type of punch mechanism for use with a punch plate 520 will now be described. The device shown in Figures 53-54 shows a mechanism that first punches and then rotates or indexes the released penetrating member into position. In this present embodiment, the cartridge is rotated first and then the gripper and punch may move down simultaneously. Figure 65A shows a punch 685 having a first portion 686 and a second portion 687. As seen in cross-sectional view of Figure 65B, the penetrating member gripper 690 is located inside the punch 685. Thus the penetrating of the sterility barrier is integrated into the step of engaging the penetrating member with the gripper 690. The punch 685 may include a slot 692 allowing a portion 694 of the gripper 690 to extend upward. A lateral opening 695 is provided from which a penetrating member may exit. In some embodiments, the punch portion 687 is not included with punch 686, instead relying on some other mechanism such as those shown in Figures 64A-64C to press down on barrier material covering a lateral opening 503.

[0134] Referring now to Figures 66, a still further embodiment of a cartridge will be described. Figure 66 shows a cartridge 700 with a plurality of cavities 702 and individual deflectable portions or fingers 704. The ends of the protective cavities 702 may be divided into individual fingers (such as one for each cavity) on the outer periphery of the disc. Each finger 704 may be individually

sealed with a foil cover (not shown for ease of illustration) to maintain sterility until the time of use. Along the inner periphery of the cartridge 700 are raised step portions 706 to create a ratchet type mechanism. As seen in Figure 67, a penetrating member 708 may be housed in each cavity. The penetrating member may rest on a raised portion 710. A narrowed portion 712 pinches the proximal portions of the penetration member 708. Each cavity may include a wall portion 714 into which the penetrating member 708 may be driven after the penetrating member has been used. Figure 68 shows the penetrating member gripper 716 lowered to engage a penetrating member 708. For ease of illustration, a sterility barrier covering each of the cavities is not shown.

[0135] Referring now to Figures 69A-69L, the sequence of steps for actuating a penetrating member in a cartridge 700 will be described. It should be understood that in other embodiments, steps may be combined or reduced. The last penetrating member to be used may be left in a retracted position, captured by a gripper 716. The end of the protective cavity 704 may be deflected downward by the previous actuation. The user may operate a mechanism such as but not limited to a thumbwheel, lever, crank, slider, etc...that advances a new penetrating member 720 into launch position as seen in Figure 69A. The mechanism lifts a bar that allows the protective cavity to return to its original position in the plane of the disc.

[0136] In this embodiment as shown in Figure 69B, the penetrating member guide 722 presses through foil in rear of pocket to "home" penetrating member and control vertical clearance. For ease of illustration, actuation devices for moving the penetrating member guide 722 and other mechanisms are not shown. They may be springs, cams, or other devices that can lower and move the components shown in these figures. In some embodiments, the cartridge 700 may be raised or lowered to engage the penetrating member guide 722 and other devices.

[0137] As seen in Figure 69C, the plough or sterile enclosure release device 724 is lowered to engage the cartridge 700. In some embodiments, the disc or cartridge 700 may be raised part way upward until a plough or plow blade 724 pierces the sterility barrier 726 which may be a foil covering.

[0138] Referring now to Figure 69D, the plough 724 clears foil from front of pocket and leaves it attached to cartridge 700. The plough 724 is driven radially inward, cutting open the sterility barrier and rolling the scrap into a coil ahead of the plough. Foil naturally curls over and forms tight coil when plough lead angle is around 55deg to horizontal. If angle of the plough may be between about 60-40deg, preferably closer to 55 degs. In some embodiments, the foil may be removed in such a manner that the penetrating member does not need to pierce any sterile enclosure materials during launch.

[0139] Referring now to Figure 69E, the gripper 716 may be lowered to engage the bare penetrating member or piercing member 720. Optionally, the disc or cartridge

8000 may be raised until the penetrating member 720 is pressed firmly into the gripper 716. Although not shown in the present figure, the penetrating member driver or actuator of the present embodiment may remain in the same horizontal plane as the penetrating member.

[0140] As seen in Figure 69F, a bar 730 may be pressed downward on the outer end 732 of the protective cavity to deflect it so it is clear of the path of the penetrating member. In the present embodiment, the bar 730 is shaped to allow the bare penetrating member 720 to pass through. It should be understood that other shapes and orientations of the bar (such as contacting only one side or part of end 732) may be used to engage the end 732.

[0141] Referring now to Figure 69G, an electrical solenoid or other electronic or feedback controllable drive may actuate the gripper 716 radially outward, carrying the bare penetrating member 720 with it. The bare penetrating member projects from the protective case and into the skin of a finger or other tissue site that has been placed over the aperture of the actuator assembly. Suitable penetrating member drivers are described in commonly assigned, copending U.S. Patent Application Ser. No. 10/127,395 (Attorney Docket No. 38187-2551) filed April 19, 2002.

[0142] Referring now to Figure 69H, the solenoid or other suitable penetrating member driver retracts the bare penetrating member 720 into a retracted position where it parks until the beginning of the next lancing cycle.

[0143] Referring now to Figure 69I, bar 730 may be released so that the end 150 returns to an in-plane configuration with the cartridge 800.

[0144] As seen in Figure 69J, the gripper 716 may drive a used bare penetrating member radially outward until the sharpened tip is embedded into a plastic wall 714 at or near the outward end 732 of the cavity thus immobilizing the contaminated penetrating member.

[0145] As seen in Figures 69K and 69L, the plough 724, the gripper 716, and penetrating member guide 722 may all be disengaged from the bare penetrating member 720. Optionally, it should be understood that the advance mechanism may lower the cartridge 700 from the gripper 716. The used penetrating member, restrained by the tip embedded in plastic, and by the cover foil at the opposite end, is stripped from the gripper. The disc or cartridge 700 may be rotated until a new, sealed; sterile penetrating member is in position under the launch mechanism.

[0146] Referring now to Figures 70 and 71, one object for some embodiments disclosed is to include blood sampling and sensing on this penetrating member actuation device. In the present embodiment, the drive mechanism (gripper 738 and solenoid drive coil 739) may be used to drive a penetrating member into the skin and couple this lancing event to acquire the blood sample as it forms at the surface of the finger. In a first embodiment shown in Figure 70, microfluidic module 740 bearing the analyte detecting member chemistry and detection device 742

(Figure 71) is couple on to the shaft of the penetrating member 720. The drive cycle described above may also actuate the module 740 so that it rests at the surface of the finger to acquire blood once the penetrating member retracts from the wound. The module 740 is allowed to remain on the surface of the finger or other tissue site until the gripper 738 has reached the back end 744 of the microfluidics module 740, at which point the module is also retracted into the casing. The amount of time the module 740 remains on the finger, in this embodiment, may be varied based on the distance the end 744 is located and the amount of time it takes the gripper to engage it on the withdrawal stroke. The blood filled module 740, filled while the module remains on pierced tissue site, may then undergo analyte detection by means such as optical or electrochemical sensing.

[0147] The blood may be filled in the lumen that the penetrating member was in or the module may have separately defined sample chambers to the side of the penetrating member lumen. The analyte detecting member may also be placed right at the immediate vicinity or slightly setback from the module opening receiving blood so that low blood volumes will still reach the analyte detecting member. In some embodiments, the analyte sensing device and a visual display or other interface may be on board the apparatus and thus provide a readout of analyte levels without need to plug apparatus or a test strip into a separate reader device. As seen in Figure 71, the cover 746 may also be clear to allow for light to pass through for optical sensing. The analyte detecting member may be used with low volumes such as less than about 1 microliter of sample, preferably less than about 0.6 microliter, more preferably less than about 0.3 microliter, and most preferably less than about 0.1 microliter of sample.

[0148] In another embodiment as seen in Figure 72, sensing elements 760 may be directly printed or formed on the top of bottom of the penetrating member cartridge 700, depending on orientation. The bare penetrating member 720 is then actuated through a hole 762 in the plastic facing, withdrawn into the radial cavity followed by the blood sample. Electrochemical or optical detection for analyte sensing may then be carried out (Figure 72). Again the cavity 766 may have a clear portion to allow light to pass for optical sensing. In one embodiment, a multiplicity of miniaturized analyte detecting member fields may be placed on the floor of the radial cavity as shown in Figure 72 or on the microfluidic module shown in Figure 71 to allow many tests on a single analyte form a single drop of blood to improve accuracy and precision of measurement. Although not limited in this manner, additional analyte detecting member fields or regions may also be included for calibration or other purposes.

[0149] Referring now to Figure 73, a still further embodiment of a cartridge will be described. Figure 73 shows one embodiment of a cartridge 800 which may be removably inserted into an apparatus for driving penetrating members to pierce skin or tissue. The cartridge

800 has a plurality of penetrating members 802 that may be individually or otherwise selectively actuated so that the penetrating members 802 may extend outward from the cartridge, as indicated by arrow 804, to penetrate tissue. In the present embodiment, the cartridge 800 may be based on a flat disc with a number of penetrating members such as, but in no way limited to, (25, 50, 75, 100, ...) arranged radially on the disc or cartridge 800. It should be understood that although the cartridge 800 is shown as a disc or a disc-shaped housing, other shapes or configurations of the cartridge may also work in order to place a plurality of penetrating members to be engaged, singly or in some combination, by a penetrating member driver.

[0150] Each penetrating member 802 may be contained in a cavity 806 in the cartridge 800 with the penetrating member's sharpened end facing radially outward and may be in the same plane as that of the cartridge. The cavity 806 may be molded, pressed, forged, or otherwise formed in the cartridge. Although not limited in this manner, the ends of the cavities 806 may be divided into individual fingers (such as one for each cavity) on the outer periphery of the disc. The particular shape of each cavity 806 may be designed to suit the size or shape of the penetrating member therein or the amount of space desired for placement of the analyte detecting members 808. For example and not limitation, the cavity 806 may have a V-shaped cross-section, a U-shaped cross-section, C-shaped cross-section, a multi-level cross section or the other cross-sections. The opening 810 through which a penetrating member 802 may exit to penetrate tissue may also have a variety of shapes, such as but not limited to, a circular opening, a square or rectangular opening, a U-shaped opening, a narrow opening that only allows the penetrating member to pass, an opening with more clearance on the sides, a slit, a configuration as shown in Figure 75, or the other shapes.

[0151] In this embodiment, after actuation, the penetrating member 802 is returned into the cartridge and may be held within the cartridge 800 in a manner so that it is not able to be used again. By way of example and not limitation, a used penetrating member may be returned into the cartridge and held by the launcher in position until the next lancing event. At the time of the next lancing, the launcher may disengage the used penetrating member with the cartridge 800 turned or indexed to the next clean penetrating member such that the cavity holding the used penetrating member is position so that it is not accessible to the user (i.e. turn away from a penetrating member exit opening). In some embodiments, the tip of a used penetrating member may be driven into a protective stop that hold the penetrating member in place after use. The cartridge 800 is replaceable with a new cartridge 800 once all the penetrating members have been used or at such other time or condition as deemed desirable by the user.

[0152] Referring still to the embodiment in Figure 73, the cartridge 800 may provide sterile environments for penetrating members via seals, foils, covers, polymeric,

or similar materials used to seal the cavities and provide enclosed areas for the penetrating members to rest in. In the present embodiment, a foil or seal layer 820 is applied to one surface of the cartridge 800. The seal layer 820 may be made of a variety of materials such as a metallic foil or other seal materials and may be of a tensile strength and other quality that may provide a sealed, sterile environment until the seal layer 820 is penetrate by a suitable or penetrating device providing a preselected or selected amount of force to open the sealed, sterile environment. Each cavity 806 may be individually sealed with a layer 820 in a manner such that the opening of one cavity does not interfere with the sterility in an adjacent or other cavity in the cartridge 800. As seen in the embodiment of Figure 73, the seal layer 820 may be a planar material that is adhered to a top surface of the cartridge 800.

[0153] Depending on the orientation of the cartridge 800 in the penetrating member driver apparatus, the seal layer 820 may be on the top surface, side surface, bottom surface, or other positioned surface. For ease of illustration and discussion of the embodiment of Figure 73, the layer 820 is placed on a top surface of the cartridge 800. The cavities 806 holding the penetrating members 802 are sealed on by the foil layer 820 and thus create the sterile environments for the penetrating members. The foil layer 820 may seal a plurality of cavities 806 or only a select number of cavities as desired.

[0154] In a still further feature of Figure 73, the cartridge 800 may optionally include a plurality of analyte detecting members 808 on a substrate 822 which may be attached to a bottom surface of the cartridge 800. The substrate may be made of a material such as, but not limited to, a polymer, a foil, or other material suitable for attaching to a cartridge and holding the analyte detecting members 808. As seen in Figure 73, the substrate 822 may hold a plurality of analyte detecting members, such as but not limited to, about 10-50, 50-100, or other combinations of analyte detecting members. This facilitates the assembly and integration of analyte detecting members 808 with cartridge 800. These analyte detecting members 808 may enable an integrated body fluid sampling system where the penetrating members 802 create a wound tract in a target tissue, which expresses body fluid that flows into the cartridge for analyte detection by at least one of the analyte detecting members 808. The substrate 822 may contain any number of analyte detecting members 808 suitable for detecting analytes in cartridge having a plurality of cavities 806. In one embodiment, many analyte detecting members 808 may be printed onto a single substrate 822 which is then adhered to the cartridge to facilitate manufacturing and simplify assembly. The analyte detecting members 808 may be electrochemical in nature. The analyte detecting members 808 may further contain enzymes, dyes, or other detectors which react when exposed to the desired analyte. Additionally, the analyte detecting members 808 may comprise of clear optical windows that allow light to

pass into the body fluid for analyte analysis. The number, location, and type of analyte detecting member 808 may be varied as desired, based in part on the design of the cartridge, number of analytes to be measured, the need for analyte detecting member calibration, and the sensitivity of the analyte detecting members. If the cartridge 800 uses an analyte detecting member arrangement where the analyte detecting members are on a substrate attached to the bottom of the cartridge, there may be through holes (as shown in Figure 76), wicking elements, capillary tube or other devices on the cartridge 800 to allow body fluid to flow from the cartridge to the analyte detecting members 808 for analysis. In other configurations, the analyte detecting members 808 may be printed, formed, or otherwise located directly in the cavities housing the penetrating members 802 or areas on the cartridge surface that receive blood after lancing.

[0155] The use of the seal layer 820 and substrate or analyte detecting member layer 822 may facilitate the manufacture of these cartridges 10. For example, a single seal layer 820 may be adhered, attached, or otherwise coupled to the cartridge 800 as indicated by arrows 824 to seal many of the cavities 806 at one time. A sheet 822 of analyte detecting members may also be adhered, attached, or otherwise coupled to the cartridge 800 as indicated by arrows 825 to provide many analyte detecting members on the cartridge at one time. During manufacturing of one embodiment disclosed, the cartridge 800 may be loaded with penetrating members 802, sealed with layer 820 and a temporary layer (not shown) on the bottom where substrate 822 would later go, to provide a sealed environment for the penetrating members. This assembly with the temporary bottom layer is then taken to be sterilized. After sterilization, the assembly is taken to a clean room (or it may already be in a clean room or equivalent environment) where the temporary bottom layer is removed and the substrate 822 with analyte detecting members is coupled to the cartridge as shown in Figure 73. This process allows for the sterile assembly of the cartridge with the penetrating members 802 using processes and/or temperatures that may degrade the accuracy or functionality of the analyte detecting members on substrate 822. As a nonlimiting example, the entire cartridge 800 may then be placed in a further sealed container such as a pouch, bag, plastic molded container, etc...to facilitate contact, improve ruggedness, and/or allow for easier handling.

[0156] In some embodiments, more than one seal layer 820 may be used to seal the cavities 806. As examples of some embodiments, multiple layers may be placed over each cavity 806, half or some selected portion of the cavities may be sealed with one layer with the other half or selected portion of the cavities sealed with another sheet or layer, different shaped cavities may use different seal layer, or the like. The seal layer 820 may have different physical properties, such as those covering the penetrating members 802 near the end of the cartridge may have a different color such as red to indicate to the

user (if visually inspectable) that the user is down to say 10, 5, or other number of penetrating members before the cartridge should be changed out.

[0157] Referring now to Figures 74 and 75, one embodiment of the microfluidics used with the analyte detecting members 808 in cartridge 800 will now be described. For ease of illustration, the shape of cavity 806 has been simplified into a simple wedge shape. It should be understood that more sophisticated configurations such as that shown in Figure 73 may be used. Figure 74 shows a channel 826 that assists in drawing body fluid towards the analyte detecting members 808. In the present embodiment, two analyte detecting members 808 are shown in the cavity 806. This is purely for illustrative purposes as the cavity 806 may have one analyte detecting member or any other number of analyte detecting members as desired. Body fluid entering cavity 806, while filling part of the cavity, will also be drawn by capillary action through the groove 826 towards the analyte detecting members 808. The analyte detecting members 808 may all perform the same analysis, they may each perform different types of analysis, or there may be some combination of the two (some sensors perform same analysis while others perform other analysis).

[0158] Figure 75 shows a perspective view of a cutout of the cavity 806. The penetrating member 802 (shown in phantom) is housed in the cavity 806 and may extend outward through a penetrating member exit opening 830 as indicated by arrow 832. The position of the tip of penetrating member 802 may vary, such as being near the penetrating member exit port or spaced apart from the exit. The location of the tip relative to the analyte detecting member 808 may also be varied, such as being spaced apart or away from the analyte detecting member or collocated or in the immediate vicinity of the analyte detecting member. Fluid may then enter the cavity 806 and directed by channel 826. The channel 826 as shown in Figure 75 is a groove that is open on top. The channel 826 may be entirely a groove with an open top or it may have a portion that is has a sealed top forming a lumen, or still further, the groove may be closed except for an opening near the penetrating member exit opening 830. It should be understood that capillary action can be achieved using a groove having one surface uncovered. In some embodiments, the analyte detecting member 808 is positioned close to the penetrating member exit opening 830 so that the analyte detecting member 808 may not need a capillary groove or channel to draw body fluid, such as in Figure 78.

[0159] As seen in Figures 75 and 76, the cavity 806 may include the substrate 822 coupled to its bottom surface containing the analyte detecting members 808. With the analyte detecting members 808 located on the underside of the cartridge 800 as seen in the embodiment of Figure 76, the cartridge 800 may include at least one through hole 834 to provide a passage for body fluid to pass from the cavity 806 to the analyte detecting member 808. The size, location, shape, and other features of the

through hole 834 may be varied based on the cavity 806 and number of analyte detecting members 808 to be provided. In other embodiments, wicking elements or the like may be used to draw body fluid from the groove 826 to down to the analyte detecting member 808 via the through hole or holes 834.

[0160] Referring now to Figure 77, a variety of groove and analyte detecting member configurations are shown on a single cartridge. These configurations are shown only for illustrative purposes and a single cartridge may not incorporate each of these configurations. Some embodiments may use any of the detecting members, singly or in combination. It should be understood, however, that analyte detecting member configuration could be customized for each cavity, such as but not limited to, using a different number and location of analyte detecting members depending lancing variables associated with that cavity, such as but not limited to, the time of day of the lancing event, the type of analyte to be measured, the test site to be lanced, stratum corneum hydration, or other lancing parameter. As a nonlimiting example, the detecting members may be moved closer towards the outer edge of the disc, more on the side walls, any combination, or the like.

[0161] Figure 77 shows a penetrating member 802 in a cavity 838 with three analyte detecting members 808 in the cavity. For ease of illustration, the penetrating member 802 is omitted from the remaining cavities so that the analyte detecting member configurations can be more easily seen. Cavity 840 has a channel 826 with two analyte detecting members 808. Cavity 842 has a channel 844 coupled to a single analyte detecting member 808. Cavities 846 and 848 have one and two analyte detecting members 808, respectively. The analyte detecting members 808 in those cavities may be located directly at the penetrating member exit from the cartridge or substantially at the penetrating member exit. Other analyte detecting member configurations are also possible, such as but not limited to, placing one or more analyte detecting members on a side wall of the cavity, placing the analyte detecting members in particular arrays (for example, a linear array, triangular array, square array, etc...) on the side wall or bottom surface, using mixed types of analyte detecting members (for example, electrochemical and optical, or some other combination), or mixed positioning of analyte detecting members (for example, at least one analyte detecting member on the substrate below the cartridge and at least one analyte detecting member in the cavity).

[0162] Figure 78 shows an embodiment of cartridge 800 where the analyte detecting member 850 is located near the distal end of cavity 806. The analyte detecting member 850 may be formed, deposited, or otherwise attached there to the cartridge 800. In another embodiment, the analyte detecting member 850 may be a well or indentation having a bottom with sufficient transparency to allow an optical analyte detecting member to detect analytes in fluid deposited in the well or indentation.

The well or indentation may also include some analyte reagent that reacts (fluoresces, changes colors, or presents other detectable qualities) when body fluid is placed in the well. In a still further embodiment, analyte detecting member 850 may be replaced with a through hole that allow fluid to pass there through. An analyte detecting member 808 on a substrate 822 may be attached to the underside of the cartridge 800, accessing fluid passing from the cavity 806 down to the analyte detecting member 808.

[0163] As mentioned above, the analyte detecting members 808 may also be placed right at the immediate vicinity or slightly setback from the module opening receiving blood so that low blood volumes will still reach the analyte detecting member. The analyte detecting members 808 may be used with low volumes such as less than about 1 microliter of sample, preferably less than about 0.6 microliter, more preferably less than about 0.3 microliter, and most preferably less than about 0.1 .microliter of sample. Analyte detecting members 808 may also be directly printed or formed on the bottom of the penetrating member cartridge 800. In one embodiment, a multiplicity of miniaturized analyte detecting member fields may be placed on the floor of the radial cavity or on the microfluidic module to allow many tests on a single analyte form a single drop of blood to improve accuracy and precision of measurement. Although not limited in this manner, additional analyte detecting member fields or regions may also be included for calibration or other purposes.

[0164] Referring now to Figures 79-84, further embodiments of the cartridge 800 will now be described. Figure 79 shows a cartridge 860 having a half-circular shape. Figure 80 shows a cartridge 862 in the shape of a partial curve. Figure 80 also shows that the cartridges 862 may be stacked in various configurations such as vertically, horizontally, or in other orientations. Figure 81 shows a cartridge 864 having a substantially straight, linear configuration. Figure 82 shows a plurality of cartridges 864 arranged to extend radially outward from a center 866. Each cartridge may be on a slide (not shown for simplicity) that allows the cartridge 864 to slide radially outward to be aligned with a penetrating member launcher. After use, the cartridge 864 is slide back towards the center 866 and the entire assembly is rotated as indicated by arrow 868 to bring a new cartridge 864 into position for use with a penetrating member driver. Figure 83 shows a still further embodiment where a plurality of cartridges 800 may be stacked for use with a penetrating member driver (see Figure 85). The driver may be moved to align itself with each cartridge 800 or the cartridges may be moved to alight themselves with the driver. Figure 84 shows a still further embodiment where a plurality of cartridge 864 are coupled together with a flexible support to define an array. A roller 870 may be used to move the cartridges 864 into position to be actuated by the penetrating member driver 872.

[0165] Referring now to Figure 85, one embodiment

of an apparatus 880 using a radial cartridge 800 with a penetrating member driver 882 is shown. A contoured surface 884 is located near a penetrating member exit port 886, allowing for a patient to place their finger in position for lancing. Although not shown, the apparatus 880 may include a human readable or other type of visual display to relay status to the user. The display may also show measured analyte levels or other measurement or feedback to the user without the need to plug apparatus 880 or a separate test strip into a separate analyte reader device. The apparatus 880 may include a processor or other logic for actuating the penetrating member or for measuring the analyte levels. The cartridge 800 may be loaded into the apparatus 880 by opening a top housing of the apparatus which may be hinged or removably coupled to a bottom housing. The cartridge 800 may also be drawn into the apparatus 880 using a loading mechanism similar in spirit to that found on a compact disc player or the like. In such an embodiment, the apparatus may have a slot (similar to a CD player in an automobile) that allows for the insertion of the cartridge 800 into the apparatus 880 which is then automatically loaded into position or otherwise seated in the apparatus for operation therein. The loading mechanism may be mechanically powered or electrically powered. In some embodiments, the loading mechanism may use a loading tray in addition to the slot. The slot may be placed higher on the housing so that the cartridge 800 will have enough clearance to be loaded into the device and then dropped down over the penetrating member driver 882. The cartridge 800 may have an indicator mark or indexing device that allows the cartridge to be properly aligned by the loading mechanism or an aligning mechanism once the cartridge 800 is placed into the apparatus 880. The cartridge 800 may rest on a radial platform that rotates about the penetrating member driver 882, thus providing a method for advancing the cartridge to bring unused penetrating members to engagement with the penetrating member driver. The cartridge 800 on its underside or other surface, may be shaped or contoured such as with notches, grooves, tractor holes, optical markers, or the like to facilitate handling and/or indexing of the cartridge. These shapes or surfaces may also be varied so as to indicate that the cartridge is almost out of unused penetrating members, that there are only five penetrating members left, or some other cartridge status indicator as desired.

[0166] A suitable method and apparatus for loading penetrating members has been described previously in commonly assigned, copending U.S. patent applications. Suitable devices for engaging the penetrating members and for removing protective materials associated with the penetrating member cavity are described in commonly assigned, copending U.S. patent applications. For example in the embodiment of Figure 78, the foil or seal layer 820 may cover the cavity by extending across the cavity along a top surface 890 and down along the angled surface 892 to provide a sealed, sterile environment for the penetrating member and analyte detecting members

therein. A piercing element described in U.S. patent applications has a piercing element and then a shaped portion behind the element which pushes the foil to the sides of the cavity or other position so that the penetrating member 802 may be actuated and body fluid may flow into the cavity.

[0167] Referring now to Figure 86, a still further embodiment of a lancing system will be described. A radial cartridge 500 may be incorporated for use with a penetrating member driver 882. A penetrating member may be driven outward as indicated by arrow 894. A plurality of analyte detecting members are presented on a roll 895 that is laid out near a penetrating member exit. The roll 895 may be advanced as indicated by arrow 896 so that used analyte detecting members are moved away from the active site. The roll 895 may also be replaced by a disc holding a plurality of analyte detecting members, wherein the analyte detecting member disc (not shown) is oriented in a plane substantially orthogonal to the plane of cartridge 500. The analyte detecting member disc may also be at other angles not parallel to the plane of cartridge 500 so as to be able to rotate and present new, unused analyte detecting member in sequence with new unused penetrating members of cartridge 500.

[0168] Referring now to Figure 87A, the cartridge 500 provides a high density packaging system for a lancing system. This form factor allows a patient to load a large number penetrating members through a single cartridge while maintaining a substantially handheld device. Of course such a cartridge 500 may also be used in non-handheld devices. The present cartridge 500 provide a high test density per volume of the disposable. For embodiments of a cartridge that includes analyte detecting members in addition to penetrating members such as cartridge 800, the density may also be measured in terms of density of analyte detecting members and penetrating members in a disposable. In other embodiments, the density may also be expressed in terms of analyte detecting members per disposable. For example, by taking the physical volume of one embodiment or the total envelope, this number can be divided by the number of penetrating members or number of tests. This result is the volume per penetrating member or per test in a cassetted fashion. For example, in one embodiment disclosed, the total volume of the cartridge 500 is determined to be 4.53 cubic centimeters. In this one embodiment, the cartridge 500 holds 50 penetrating members. Dividing the volume by 50, the volume per test is arrived at 0.090 cubic centimeters. Conventional test devices such as drum is in the range of 0.720 or 0.670 cubic centimeters and that is simply the volume to hold a plurality of test strips. This does not include penetrating members as does the present embodiment 800. Thus, the present embodiment is at a substantially higher density. Even a slightly lower density device having penetrating members and analyte detecting members in the 0.500 cubic centimeter range would be a vast improvement over known devices since the numbers listed above for known

devices does not include penetrating members, only packaging per test strip.

[0169] Each penetrating member (or penetrating member and analyte detecting member, as the case may be) may have a packing density, or occupied volume, in cartridge 500. In various embodiments, the packing density or occupied volume of each penetrating member in cartridge 500 may be no more than about 0.66 cm³, 0.05 cm³, 0.4 cm³, 0.3 cm³, 0.2 cm³, 0.1 cm³, 0.075 cm³, 0.05 cm³, 0.025 cm³, 0.01 cm³, 0.090 cm³, 0.080 cm³, and the like. These numbers applicable to volumes for penetrating members alone, or for combined penetrating members and analyte detecting members. In other words, the volume required for each penetrating member does not exceed 0.66 cm³/penetrating member, 0.05 cm³/penetrating member, 0.4 cm³/penetrating member, 0.3 cm³/penetrating member, 0.2 cm³/penetrating member, 0.1 cm³/penetrating member, 0.075 cm³/penetrating member, 0.05 cm³/penetrating member, 0.025 cm³/penetrating member, 0.01 cm³/penetrating member, 0.090 cm³/penetrating member and the like. So, if the total package volume of the cartridge is defined as X and the cartridge includes Y number of penetrating members, penetrating members and test area, or other unit 395, the volume for each unit does not exceed 0.66 cm³, 0.05 cm³, 0.4 cm³, 0.3 cm³, 0.2 cm³, 0.1 cm³, 0.075 cm³, 0.05 cm³, 0.025 cm³, 0.01 cm³, 0.090 cm³, 0.080 cm³, and the like.

[0170] Referring now to Figure 87B, a still further embodiment of a cartridge will now be described. Figure 87B shows a cross-section of a conical shaped cartridge with the penetrating member being oriented in one embodiment to move radially outward as indicated by arrow 897. In another embodiment, the penetrating member may be oriented to move radially inward as indicated by arrow 895. The gripper may be positioned to engage the penetrating member from an inner surface or an outer surface of the cartridge.

[0171] Referring now to Figure 88, nanowires may also be used to create low volume analyte detecting members used with the cartridge 800. Further details of a nanowire device is described in commonly assigned, copending U.S. Provisional Patent Application filed December 13, 2002. These nanowire analyte detecting members 898 may be incorporated into the cavity 806 housing the penetrating member 802. They may be placed on the floor or bottom surface of the cavity 806, on the wall, on the top surface, or any combinations of some or all of these possibilities. The analyte detecting members 898 may be designed to have different sensitivity ranges so as to enhance the overall sensitivity of an array of such analyte detecting members. Methods to achieve this may include, but are not limited to, using nanowires of varying sizes, varying the number of nanowires, or varying the amount of glucose oxidase or other glucose detection material on the nanowires. These nanowire analyte detecting members may be designed to use low volumes of body fluid for each sample, due to their size. In some

embodiments, each of the analyte detecting members are accurate using volumes of body fluid sample less than about 500 nanoliters. In some embodiments, each of the analyte detecting members are accurate using volumes of body fluid sample less than about 300 nanoliters. In still other embodiments, each analyte detecting member is accurate with less than about 50 nanoliters, less than about 30 nanoliters, less than about 10 nanoliters, less than about 5 nanoliters, and less than about 1 nanoliters of body fluid sample. In some embodiments, the combined array of analyte detecting members uses less than 300 nanoliters of body fluid to arrive at an analyte measurement.

[0172] Referring now to Figure 89, a still further embodiment will be described. Figure 89 shows one embodiment of an optical illumination system 910 for use with optical analyte detecting members (Figure 91) that may be in contact with a body fluid sample. The overall system may include a plurality of analyte detecting members which provide some optical indicator, a light source 912 for providing light to shine on the analyte detecting members, at least one light detector 914, and a processor (not shown). The analyte detecting member or analyte detecting members are exposed to a sample of the fluid of unknown composition. A plurality of analyte detecting members may be arranged into an array of analyte detecting members exposed to one fluid sample, each group targeting a specific analyte and may contain an analyte-specific chemical that interacts more specifically with one analyte than with some other analytes to be analyzed. Each analyte detecting member may also have different sensitivity ranges so as to maximize overall sensitivity of an array of such analyte detecting members. The light source 912 shines light on at least one analyte detecting member to cause light interaction. The differences in the analyte detecting members may lead to differences in the light interaction. The light detector detects the light interaction by the analyte detecting members. The processor analyzes the light interaction by the analyte detecting members to take into account interference in light interaction among the analytes, thereby determining the concentration of the desired analyte in the fluid.

[0173] Referring still to the embodiment of Figure 89, the light source 912 may be but is not limited to an LED. An alternative LED 915 may also be used. Light, illumination, or excitation energy from LED 912 travels along a path through a pinhole 916, a filter 917, and a lens 918. The light then comes into contact with a beamsplitter 919 such as a dichroic mirror or other device useful for beamsplitting. The light is then directed towards lens 920 as indicated by arrow 921. The lens 920 focuses light onto the analyte detecting member (Figure 91). This excitation energy may cause a detectable optical indicator from the analyte detecting member. By way of example and not limitation, fluorescence energy may be reflected bay up the lens 920. This energy passes through the beamsplitter 919 and to lens 922 which is then received by detector 914 as indicated by arrow 923. The detector 914 meas-

ures the energy and this information is passed on to the processor (not shown) to determine analyte levels. The illumination system 910 may also include cells 924 on the disc surface. In this specific embodiment, a penetrating member 925 drive by a force generator 926 such as but not limited to a solenoid may be used to obtain the fluid sample. A detent 927 may also be included with the device along with other bare lancets or penetrating members 928.

[0174] Referring now to Figure 90, another embodiment of the illumination system 910 is shown for use with a cartridge 929. Cartridge 929 is similar to cartridge 800. Cartridge 929 is a single cartridge having a plurality of penetrating members and a plurality of optical analyte detecting members (not shown). The cartridge 929 further includes a plurality of optically transparent portions 930 which may be but is not limited to windows or the like for the light from LED 912 to shine into a cavity of the cartridge 929. In one embodiment, each cavity of the cartridge 929 may include at least one transparent portion 930. This allows the light to generate energy that may be read by analyte detecting member 914. The cartridge 929 may be used a driver 882 to actuate penetrating members and the cartridge 929 may rotate as indicated by arrow 931.

[0175] Referring now to Figure 91, a cross-section of a similar embodiment of the illumination system is shown. This system 932 has source 912 with a lens 933 having an excitation filter 934. This excitation filter 934, in one embodiment, only allows excitation energy to pass. This filter 934 allows the excitation energy to pass to dichroic mirror 935, but does not let it return to source 912. Excitation energy is reflected down as indicated by arrow 936. Lens 937 focuses the energy to optical analyte detecting member 938. Fluorescence energy 939 passes through the dichroic mirror 935 and towards a fluorescent filter 940. In one embodiment, the fluorescent filter 940 only allows fluorescent energy to pass through to lens 941. Thus, the detector 914 only receives fluorescent energy from the analyte detecting member 938. It should be understood of course, that the filter may be changed to allow the type of energy being generated by analyte detecting member 938 to pass. In some embodiments, no filter may be used. The dichroic mirror 935 may be a Bk7 substrate, 63x40x8mm. The filters may also be a Bk7 substrate about 40mm in diameter and about 6mm thick. The lens 933, 937, and 941 may be achormat:bfl=53.6, working aperture 38mm.

[0176] Referring now to Figure 92, a still further embodiment of an illumination system 942 will be described. This system does not use a beamsplitter or dichroic mirror. Instead, both the source or LED 912 and detector 914 have direct line of sight to the optical analyte detecting member 938. In this embodiment, multiple elements are combined into a single housing. For example, lens 943, lens 944, and filter 945 are combined while lens 946, lens 947, and filter 948 are also combined.

[0177] Referring now to Figure 93, a cross-section of

a system similar to that of Figure 89 is shown in a housing 950. LED 912 sends light to mirror 919 to a light path 951 to cells 924 on a surface of the disc. A finger access 952 allows a sample to be obtained and flow along a fluid pathway 953 to be analyzed. A processor 954 may be coupled to detector 914 to analyze the results.

[0178] Referring now to Figure 94, a cross-section of a system similar to that of Figure 90 will be further described. This shows a cartridge 929 used with a driver 882. This allows for a radial design where the penetrating members extend radially outward as indicated by arrow 955. The driver 882 may have a coupler portion that reciprocates as indicated by arrow 956. Figures 95 and 96 provide further views of a system similar to that of Figure 89. The embodiment of Figures 95 and 96 may include additional lenses or filters as may be useful to refine energy detection.

[0179] Figure 97 shows an embodiment previously described where the penetrating member 1010 and analyte detecting member 1012 are combined on the same disposable platform such as a radial cartridge 1014. Such a configuration is shown in commonly assigned, co-pending U.S. Patent Application Ser. No. 10/429,196 filed May 1, 2003.

[0180] In one manufacturing process, penetrating members 1010 are sterilized in a first step, a seal is removed from the bottom of the platform or cartridge 1014 and analyte detecting members are bonded on in a second step. This involves the manufacturer of the penetrating member disposable taking part with the design, specification and assembly of the entire disposable.

[0181] Referring now to Figure 98, an embodiment will now be described. Figure 98 shows a separate cartridge for use with a cartridge contain a plurality of penetrating members.

[0182] Here in Figure 98, a separate sensor ring or cartridge 1020 is fixed to the multiple penetrating member cartridge (see Figure 99) by a method such as, but not limited to, bonding, snap fitting, heat staking or the like, to form the complete disposable. Particular attention in this embodiment has been paid to the configuration of the front end or finger to disposable interface. Skin stabilization during the lancing event is known to affect the likelihood that blood will exit the wound and flow freely into the sample acquisition chamber. Finger positioning and skin stabilization is achieved through molded indents 1024 on the front of the analyte detecting member cartridge 1020. The penetrating member enters and exits through the hole in the center of the indents and fluid is draw into a channel, which transects the front end to flow down into the sensor chambers, which are located on the bottom of the disposable. One advantage is a large surface area for bonding the two discs together.

[0183] Figure 99 shows yet another embodiment where the penetrating member 1010 and analyte detecting member 1022 are fluidically collocated and in the same plane as the wound channel formed in the skin during the lancing event. For the purpose of illustration,

the analyte detecting members 1022 have been drawn at the front of the ring 1020 where the sample path is the shortest distance to the analyte detecting member 1022. The finger may then come in contact with the front pocket to direct the blood sample from the wound into the sensor chamber. The front pocket can have a wide variety of shapes can be envisaged which maximize the likelihood of blood exiting the wound after lancet retraction and entering the sample test chamber. The penetrating member and analyte detecting member disposable are manufactured separately, bonded together and can be kept in separate sterilized compartments. What is not shown is that the analyte detecting member can be connected with the penetrating member and fluidic sample channel by simply peeling a patch from the front end. Adjacent lancet and detecting member pairs remain uncontaminated by their "used" neighbors and are sterile until used. Penetrating member 10 and analyte detecting members 1022 can then be sterilized by independent methods that are best suited to each.

[0184] Figure 100 shows one embodiment of the underside of the disposable or cartridge 1020 showing the location of the contact pads 1030 coupled to the analyte detecting members 1022.

[0185] These drawings serve to illustrate the various ways in which analyte detecting members can be located on the lancet cartridge so that each portion of the multi-lancet multi analyte detecting member disposable can be manufactures and sterilized separated. To integrate multiple analyte detecting members with a multiple penetrating member cartridge, a separate ring containing the analyte detecting members for performing the diagnostics tests can be manufactured. The ring can have a variety of configurations to position the analyte detecting member with respect to the lancet and the wound.

[0186] Figure 101 shows a still further embodiment where the ring 1020 may be configured to rotate about a single penetrating member actuator 1040. Hence, the sensor cartridge or ring 1020 will rotate about the penetrating member driver. In this embodiment the penetrating member may be reused while new analyte detecting members on the ring 1020 are brought into alignment. This embodiment shows a single penetrating member for use (and reused in some embodiments of the invention) with a plurality of new, unused analyte detecting members. The ring 1020 may also be individually rotatable (i.e. not fixedly coupled) to the radial cartridge 1100 having a plurality of penetrating members.

[0187] Figure 102 shows a still further view of the embodiment shown in Figure 99. Figure 103 shows a close up of the front end having the analyte detecting members 1022 and the location of the penetrating member 1010. As can be seen in Figure 103, a opening 1110 may be provided to allow body fluid to flow down to the analyte detecting member 1022. In some embodiments, a mesh member 1120 (see Figure 102) may cover the analyte detecting members 1022 to draw blood or body fluid to the members 1022. Some embodiments may use a wick-

ing member.

[0188] Figure 104 shows an isolation view of the portion 1128 having analyte detecting members 1022. This portion may be coupled to the ring or cartridge 1020 and may contain the sensory material.

[0189] Referring now to Figure 105, a still further embodiment is shown. Here the sensor cartridge 1020 has a strip portion 1130 that is pierced at location 1132. The strip portion 1130 may be at an angle as shown. The angles in some embodiments may be, but are not limited to, 20, 25, 30, 35, 40, 45, 50, 55, 60, 65, 70, 75, 80, 85, or 90 degrees from vertical. It should be understood of course that the strip portion 1130 may be at other angles. The strip portion 1130 may also have different shapes such as a round cross-section, triangular, oval, polygonal, other shapes, or any combination of the above. The distance 1140 between the portion 1130 and the sterility barrier 1142 can also be varied for greater or shorter lengths.

[0190] The method of use involves using a punch as described in Attorney Docket No. 38187-2662 to pierce a sterility barrier. Breaking the sterility barrier allows the penetrating member 1010 to be actuated without contacting the barrier. The strip portion 1130 will then be in position to receive body fluid when the penetrating member 1010 is actuated and pierces tissue.

[0191] In one aspect, it is desired to provide a multiple analyte detecting member ring that holds multiple analyte detecting members for diagnostic tests. In one embodiment it may be separately constructed component that fits a multiple penetrating member cartridge. In one embodiment, it does not need to go through the same sterilization cycle as the multiple penetrating member cartridge and is attached to the multiple penetrating member cartridge later in the manufacturing process to complete the product. In a still further embodiment, it can have an unlimited analyte detecting member locations with one of the locations being in the front pocket for a shorter micro fluidic pathway. It can use micro fluidic technology and can work with out micro fluidic technology. Embodiments can be manufactured in volume in a variety of ways and can be sealed with desiccant using a variety of methods. For example, Figure 106 shows a dessicant 1150 attached on the portion 1130. Dessicant 1150 can also be housed in portion 1130. It can be designed integral to the cartridge, which would have features to open the analyte detecting member seal prior to use. Some embodiments can have a plasma separation filter installed in the sample path to separate serum from whole blood which could increase the variety of diagnostics analyte detecting members that can be used in the product.

[0192] Referring now to Figure 107, yet another embodiment of a ring 1200 having a plurality of analyte detecting members 1210 is shown. The ring 1200 may be formed a linear tape of analyte detecting member 1210 formed into a circular configuration as shown in Figure 107. The analyte detecting member 1210 may include a plurality of apertures 1220 to allow for a penetrating mem-

ber (not shown) to pass through to penetrate tissue. In the present embodiment, the analyte detecting member 1210 may have three electrodes 1222, 1224, and 1226. The electrodes are coupled to the appropriate electrical contacts 1230. It should be understood that in some embodiments, the linear tape of analyte detecting members 1210 may be "folded" in a reverse manner so that the outer surface of the ring 1210 as seen in Figure 107 will now be the inner surface of the ring 1210. Thus the leads 1230 will be on the inner surface and the plain backing 1232 will now face outward. As seen in Figure 108, having this reverse configuration allows the electrodes to be on the side of the analyte detecting member that first receives body fluid as indicated by arrow 1234. The embodiment of Figure 108 may also be formed or attached to the outer circumferential surface of the cartridge. The surface may be treated to be sterile and/or hydrophilic or hydrophobic and thus the layer 1227 is not necessary, simplifying manufacturing. The surface of the cartridge will take the place of layer 1227 to contain the fluid. It should also be understood that the drawing of Figure 108 is not to scale and the electrodes 1222-1226 may be much smaller and closer to the penetrating member, such as but not limited to being within about 4, 3, 2, 1, or 0.5 mm from the opening 1220.

[0193] Referring back to Figure 107, the orientation of the analyte detecting members 1210 is orthogonal to the orientation of the penetrating member. The penetrating member moves through the aperture 1220, through a sample capture port (not shown) to pierce into the skin or tissue and retract. In one embodiment, the blood sample may move by capillary or wicking action across the electrodes 1222, 1224, and/or 1226. There may be wicking material used on all or part of the sample capture or transport area. The sample volume for this configuration is relatively small, less than 300 nl. In some embodiments, the amount in the analyte detecting member is about 60 to 70 nl. The required space for the capillary and electrodes is relatively small, less than 20 mm². In one embodiment, the range of the aperture 1220 is about 0.5 -1.0 mm.

[0194] Figure 109 shows another orientation for the electrodes 1222, 1224, and 1226 relative to the opening 1220. The contact pad 1230 may also be appropriately moved to facilitate engagement with contacts on the device holding the cartridge. The channel receiving body fluid 1241 may be at 20, 30, 35, 40, 45, 50, 60, 70, 80, 90, or other angles relative to horizontal. In some embodiments, the aperture is about 0.5 to 1.0 mm, the PSA aperture is about 1.5 to 2.5 mm, the top film and front film width is about 1.3 -2.3 mm. The volume of sample fluid used may be about 0.5mm x 2.5 mm x .05mm in on embodiment.

[0195] Referring now to Figures 110A-110C, one embodiment of one analyte detecting member 1210 will now be described. The analyte detecting members 1210 may have a outside surface layer 1240, a film layer 1242, an adhesive layer 1244, and a substrate 1246.

[0196] Referring now to Figures 111A-111C, another embodiment of one analyte detecting member 1210 will now be described. The analyte detecting members 1210 may have a outside surface layer 1240, a film layer 1242, an adhesive layer 1244, and a substrate 1246. In some embodiments, the layer 1244 may be a PSA layer. The member 1210 may include a further element which is a mesh layer 1250. As seen, in this one embodiment, the mesh layer 1250 is positioned to receive fluid from the aperture 1220 and only covers one electrode 1222. In other embodiments, the mesh layer 1250 may only be in the aperture area and not cover the electrode 1222.

[0197] Referring now to Figures 112A-112C, another embodiment of one analyte detecting member 1210 will now be described. The analyte detecting members 1210 may have a outside surface layer 1240, a film layer 1242, an adhesive layer 1244, and a substrate 1246. As seen, in this one embodiment, the mesh layer 1250 is positioned to receive fluid from the aperture 1220 and only covers one electrode 1222, 1224, and 1226. It should be noted that the electrodes on the substrate may be wide enough to be covered by the adhesive layer 1244. This allows for easier alignment during assembly. Optionally, other embodiments may have the electrodes sized to fit exactly in the opening.

[0198] The surface energy requirements of the sample capture and transport surface is minimal due to the small size and simple configuration. The configuration is relatively simple to build using layers of films and adhesives.

[0199] In some embodiments, the electrodes may run parallel in a rectangular capillary or have another configuration in other embodiments. In one embodiment, the distance from the lancet aperture to the electrodes is very small, less than 2 mm. The front face may be arrayed into a multiple sensor configuration. The electrode leads may be registered to a corner of the structure to provide a connection to the meter device.

[0200] As seen in Figure 113, some embodiments may use individual analyte detecting member 1210 and mated with a cage 1270 to hold them in position for use with a disc or cartridge containing a plurality of penetrating members. The cage 1270 may be integrally formed with the cartridge holding the plurality of penetrating members or it may be formed separately and then coupled to the cartridge. As seen in Figure 113, some embodiments of the device may have fewer than 50 penetrating members.

[0201] Referring now to Figure 114, a cross-section of yet another embodiment of the present invention will now be described. This cross-section shows a cartridge 1290 holding a penetrating member 1292 in a cavity 1294. From a wound created in target tissue by the penetrating member 1292, body fluid will contact electrodes 1296 positioned around the exit port 1297 of the penetrating member 1292. It should be understood that the electrodes 1296 may be arranged in a variety of configurations about the exit port 1297. Some embodiments may have all the electrodes 1296 below the port 1297. Some embodiments may have all of the electrodes 1296 above

the port 1297. Some may have the members 1296 distributed about the opening as shown in figure 114. Some embodiments may have a mesh that covers the members 1296 or comes next to the members and brings body fluid to the members 1296. In still other embodiments an outer ring portion 1300 maybe formed separate from portion 1302 and then the two portions are integrally joined to form a single integral unit. The joining may occur by adhesives, bonding, heat bonding, interlocking coupling, or other methods. This may facilitate manufacture of parts that may use different sterilization methods. A sterility seal (not shown) such as but not limited to a foil may be placed over the outer circumference of the ring and may be peeled back to open each individual port 1297. In other embodiments, the sterility seal may be punched open by a device such as but not limited to a separate punch device, the penetrating member, or a combination of the two.

[0202] Referring now to Figure 115, a cross-section of yet another embodiment will now be described. Figure 115 shows a cartridge 1310 with a penetrating member 1312. In one embodiment, a ring portion 1318 is coupled to the cartridge 1310. In some embodiments, the ring portion 1318 may be integrally formed with the cartridge 1310. In other embodiments, the two portions are integrally joined to form a single integral unit. The joining may occur by adhesives, bonding, heat bonding, interlocking coupling, or other methods. This may facilitate manufacture of parts that may use different sterilization methods. An opening 1320 may be provided to allow any sterility seals on the cartridge 1310 to be opened. A punch or other mechanism may extend down through the opening 1320 to piece the seal and clear it from the path of the penetrating member 1312.

[0203] As seen in Figure 115, an analyte detecting member 1326 may be housed in the portion 1318. The analyte detecting member 1326 may be similar to embodiments shown in Figures 110-112. A groove 1330 in the portion 1318 may be formed to hold the member 1326. A plurality of analyte detecting members 1326 may also be placed on a ribbon and then placed in a groove 1330 that runs around the circumference of the disc. Openings 1332 allow for the penetrating member to exit.

[0204] Referring now to Figures 116 and 117, a variety of electrode configuration are shown. In Figure 116, a penetrating member 1340 is shown. Body fluid 1342 is shown to be surround the penetrating member 1340. This may result after the penetrating member 1340 has formed a wound in the tissue and body fluid has now been received. The electrodes 1344 may be laid out in a concentric formation as seen in Figure 116. Hydrophillic elements or capillary members may be positioned as indicated by arrow 1346 to draw body fluid to the electrodes 1344. Figure 117 shows a sip-in configuration with the electrodes 1344 in the layout shown.

[0205] Referring now to Figure 118, an embodiment is shown where the electrodes 1344 are significantly smaller than the diameter of the penetrating member 1340.

The volume used for all three electrodes may be as low as 40 nanoliters.

[0206] Figures 119 and 120 show two side views of embodiments of the device 1410, Figure 119 depicts one embodiment comprising a generic polymer dielectric thick film serving as an insulating support structure 1412. The support structure 1412 may be, but is not limited to, Mylar, Tyvek, polymer or plastic film insulators. On the top side of the insulating structure 1412 are electrochemical sensory material 1414 and on the bottom side of the insulating structure 1412 are electrical signal conductors 1416 for the sensors. The materials 1414 and 1416 are coupled together through a via hole structure 1418. The material 1414 may be include, but is not limited to, carbon ink, silver ink, or other electrically conductive material.

[0207] Figure 120 depicts an application of the device 1410. The support structure 120 is being used to provide isolation and sensory material isolation from the bottom environment. In one embodiment, the top would be sealed or isolated from the environment to maintain a sterile condition prior to use, while the bottom would be exposed to the environment and allow the instrumentation access to the electrical sensory signals from the sensory material. Although this embodiment is shown with three sensors, it should be understood that different numbers of sensor or sensory material 1414 (greater or fewer) may be used. Some embodiments have may use one via hole structure 1418 to join multiple sensors 1414 to a single pad 1416, multiple pads 1416 to a single sensor 1414, multiple sensors 1414 to multiple pads 1416, or any other combination of pads to sensors.

[0208] This device is intended to allow the conduction of sensory device signals to pass through a support and insulated plate structure 1412. The insulated plate 1412 maybe fabricated from polymer materials, known to those practicing the arts, of which the conductive material is a deposited carbon based compound. The deposition of such a thick film forming the plate 1412 is generated thru the art known as "screen printing" or "thick film lithography". In one embodiment, the thick film is annealed as to remove any liquid carrier and to conductive as well as structure sound to support the deposition of sensory electrochemical material and devices. The thickness of such conductive material is typically in the range of 1 to 10 "mils" or 100's of "microns". The problem that it is solved is the ability to deposit sensory material on the topside of the film for exposure to bodily fluids via a lancing, sampling, and capturing structure or device. The device allows the electrical signals from the sensory material to be conducted and transported to the instrumentation electronics on the backside of the device such that the electrical conductors are not exposed to the bodily fluids. Also the topside of the film containing the sensory material adjacent to the lancing and sample capturing structures may be sterilized or cleaned and stored until it becomes necessary to be utilized.

[0209] The electrical via 1418 through the structural dielectric polymer may take various shapes and ge-

ometries as to provide structural support for the thick film conductive layer. As a nonlimiting example, the via 1418 may be circular, square, triangular, rectangular, polygonal, oval, or the like. Such patterns used for structural means are known to those practicing the arts of thick film depositions. The density and viscosity of the conductive film both cured and uncured is able to provide proper signal conductivity and sensory material structural support.

[0210] Referring now to Figures 121 through 124, another method of implementing such a feed thru or via structure 1418 is to use distinct plated feed thru pads 1430 (Figure 122) that are removed from the sensor area in order to provide an adequate metal coverage for insuring feed thru reliability and the possible need to enable conductor line and conductor pad placement in accessible regions of the structure backside. Advantages of such a need would be to possibly reduce cost, allow additional devices to be placed on the entire unit, or strategic conductor routing as to reduce electrical impedance or electronic noise. The overall method is shown in Figures 123 and 124. As can be seen in Figure 124, conductor pads 1430 are mounted on the bottom side of the support 1412. Figure 123 shows a top side view where the conductor lines 1432 lead from the pads 1430 to the electrodes 1434 which have the sensory material 1414. Figure 121 shows one embodiment with sizing for the particular embodiment shown.

[0211] Figures 125 and 126 provide additional details of the line conductors, feed-throughs, and conductor pads. The embodiment shown in the Figures 125 and 126 may be adapted for use with a radial cartridge such as that shown in commonly assigned, copending U.S. Patent Application Ser. No. 10/429,196 (Attorney Docket No. 38187-2662) filed May 1, 2003, fully incorporated herein by reference for all purposes. Figure 125 shows a support structure 1412 that is adapted for use with a radial cartridge. The support 1412 may include a plurality electrodes such as, but not limited to, a working electrode 1440, a counter electrode 1442, and a reference electrode 1444. A plurality of conduction lines 1450 may be used as leads to connect the electrodes having the sensory material 1414 with the contact pad 30 on the other side of the support 1412 (see Figure 126). The contact pad 1430 may be substantially larger in width than the conduction lines 1450. This facilitates the tolerance of the pad to slight misalignments of the pad with connectors or contacts on a measurement device. The contact pads 1430 are shown to be square or rectangular in geometry. It should be understood, however, that the contact pads 1430 may be circular, oval, polygonal, triangular, any single combination of the geometries above, or any combination of any number of the geometries above. The via holes may also be sufficiently spaced apart such that there is sufficient space on the underside of the support structure to accommodate the larger contact pads 1430.

[0212] The top side of the support 1412 may include a sealing region 1460. This sealing region 60 may be

used to keep the sensor material 1414 in a sealed environment prior to use.

[0213] Figure 127 shows how one embodiment of a radial cartridge 1500 may be coupled to a sterility barrier 1502 and a support 1412 having the sensor material 1414 and contact pads 1430. Of course, the support 1412 of Figure 127 may be configured to include configuration shown Figures 125 and 126. The support 1412 would be sealed, in one embodiment, against the underside of the radial cartridge 1500. This integrates the sensory material 1414 with the cartridge and also creates the sealed environment in which the material 1414 may be stored until ready for use.

[0214] While the invention has been described and illustrated with reference to certain particular embodiments thereof, those skilled in the art will appreciate that various adaptations, changes, modifications, substitutions, deletions, or additions of procedures and protocols may be made without departing from the scope of the invention. For example, with any of the above embodiments, the location of the penetrating member drive device may be varied, relative to the penetrating members or the cartridge. With any of the above embodiments, the penetrating member tips may be uncovered during actuation (i.e. penetrating members do not pierce the penetrating member enclosure or protective foil during launch). With any of the above embodiments, the penetrating members may be a bare penetrating member during launch. With any of the above embodiments, the penetrating members may be bare penetrating members prior to launch as this may allow for significantly tighter densities of penetrating members. In some embodiments, the penetrating members may be bent, curved, textured, shaped, or otherwise treated at a proximal end or area to facilitate handling by an actuator. The penetrating member may be configured to have a notch or groove to facilitate coupling to a gripper. The notch or groove may be formed along an elongate portion of the penetrating member. With any of the above embodiments, the cavity may be on the bottom or the top of the cartridge, with the gripper on the other side. In some embodiments, analyte detecting members may be printed on the top, bottom, or side of the cavities. The front end of the cartridge may be in contact with a user during lancing. The same driver may be used for advancing and retraction of the penetrating member. The penetrating member may have a diameters and length suitable for obtaining the blood volumes described herein. The penetrating member driver may also be in substantially the same plane as the cartridge. The driver may use a through hole or other opening to engage a proximal end of a penetrating member to actuate the penetrating member along a path into and out of the tissue. The sensory material may be deposited into the via holes. The conductor material may also be deposited into the via holes. The via holes may be formed by a variety of methods including micro drilling, laser drilling, plasma etching, or the like.

[0215] Any of the features described in this application

or any reference disclosed herein may be adapted for use with any embodiment of the present invention. For example, the devices of the present invention may also be combined for use with injection penetrating members or needles as described in commonly assigned, copending U.S. Patent Application Ser. No. 10/127,395 (Attorney Docket No. 38187-2551) filed April 19, 2002. An analyte detecting member to detect the presence of foil may also be included in the lancing apparatus. For example, if a cavity has been used before, the foil or sterility barrier will be punched. The analyte detecting member can detect if the cavity is fresh or not based on the status of the barrier. It should be understood that in optional embodiments, the sterility barrier may be designed to pierce a sterility barrier of thickness that does not dull a tip of the penetrating member. The lancing apparatus may also use improved drive mechanisms. For example, a solenoid force generator may be improved to try to increase the amount of force the solenoid can generate for a given current. A solenoid for use with the present invention may have five coils and in the present embodiment the slug is roughly the size of two coils. One change is to increase the thickness of the outer metal shell or windings surround the coils. By increasing the thickness, the flux will also be increased. The slug may be split; two smaller slugs may also be used and offset by $\frac{1}{2}$ of a coil pitch. This allows more slugs to be approaching a coil where it could be accelerated. This creates more events where a slug is approaching a coil, creating a more efficient system.

[0216] In another optional alternative embodiment, a gripper in the inner end of the protective cavity may hold the penetrating member during shipment and after use, eliminating the feature of using the foil, protective end, or other part to retain the used penetrating member. Some other advantages of the disclosed embodiments and features of additional embodiments include: same mechanism for transferring the used penetrating members to a storage area; a high number of penetrating members such as 25, 50, 75, 100, 500, or more penetrating members may be put on a disk or cartridge; molded body about a lancet becomes unnecessary; manufacturing of multiple penetrating member devices is simplified through the use of cartridges; handling is possible of bare rods metal wires, without any additional structural features, to actuate them into tissue; maintaining extreme (better than 50 micron -lateral- and better than 20 micron vertical) precision in guiding; and storage system for new and used penetrating members, with individual cavities/slots is provided. The housing of the lancing device may also be sized to be ergonomically pleasing. In one embodiment, the device has a width of about 56 mm, a length of about 105 mm and a thickness of about 15 mm. Additionally, some embodiments of the present invention may be used with non-electrical force generators or drive mechanism. For example, the punch device and methods for releasing the penetrating members from sterile enclosures could be adapted for use with spring based

launchers. The gripper using a frictional coupling may also be adapted for use with other drive technologies.

[0217] Still further optional features may be included with the present invention. For example, with any of the above embodiments, the location of the penetrating member drive device may be varied, relative to the penetrating members or the cartridge. With any of the above embodiments, the penetrating member tips may be uncovered during actuation (i.e. penetrating members do not pierce the penetrating member enclosure or protective foil during launch). The penetrating members may be a bare penetrating member during launch. In some embodiments, the penetrating member may be a patent needle. The same driver may be used for advancing and retraction of the penetrating member. Different analyte detecting members detecting different ranges of glucose concentration, different analytes, or the like may be combined for use with each penetrating member. Non-potentiometric measurement techniques may also be used for analyte detection. For example, direct electron transfer of glucose oxidase molecules adsorbed onto carbon nanotube powder microelectrode may be used to measure glucose levels. In some embodiments, the analyte detecting members may formed to flush with the cartridge so that a "well" is not formed. In some other embodiments, the analyte detecting members may formed to be substantially flush (within 200 microns or 100 microns) with the cartridge surfaces. In all methods, nanoscopic wire growth can be carried out via chemical vapor deposition (CVD). In all of the embodiments, preferred nanoscopic wires may be nanotubes. Any method useful for depositing a glucose oxidase or other analyte detection material on a nanowire or nanotube may be used with the present invention. Additionally, for some embodiments, any of the cartridge shown above may be configured without any of the penetrating members, so that the cartridge is simply an analyte detecting device. Still further, the indexing of the cartridge may be such that adjacent cavities may not necessarily be used serially or sequentially. As a nonlimiting example, every second cavity may be used sequentially, which means that the cartridge will go through two rotations before every or substantially all of the cavities are used. As another nonlimiting example, a cavity that is 3 cavities away, 4 cavities away, or N cavities away may be the next one used. This may allow for greater separation between cavities containing penetrating members that were just used and a fresh penetrating member to be used next. It should be understood that the spring-based drivers shown in the present invention may be adapted for use with any of the cartridges shown herein such as, but not limited to, those shown in Figures 61 and 62. These spring-based drivers may also be paired with gripper blocks that are configured to penetrate into cartridges that fully seal penetrating member therein, in order engage those penetrating members. The start and end positions of the penetrating members may also be the same. The penetrating members may be parked in a holder before actuation, and in some embod-

iments, into a holder after actuation (as seen in cartridge 500 or any other cartridge herein). Embodiments of the present invention may also include guides which provide lateral constraints and/or vertical constraints about penetrating member. These constraints may be positioned about the shaft portions of the penetrating member. For any of the embodiments herein, they may be configured to provide the various velocity profiles described. The analyte detecting members may use volumes of less than 1 microliter, less than 500nl, 400nl, 300nl, 200nl, 100nl, 75nl, 60nl, 50nl, 40nl, 30nl, 20nl, 10nl, or less of body fluid. In some embodiments, the chamber that holds the body fluid over the electrodes is less than 1 microliter, less than 500nl, 400nl, 300nl, 200nl, 100nl, 75nl, 60nl, 50nl, 40nl, 30nl, 20nl, 10nl, or less in volume. In still other embodiments, the volume of the chamber over the electrodes is less than 1 microliter, less than 500nl, 400nl, 300nl, 200nl, 100nl, 75nl, 60nl, 50nl, 40nl, 30nl, 20nl, 10nl, or less. Any of the features set forth in the present description may be combined with any other feature of the embodiments set forth above.

[0218] This application cross-references commonly assigned copending U.S. Patent Applications Ser. No. 10/323,622 (Attorney Docket No. 38187-2606) filed December 18, 2002; commonly assigned copending U.S. Patent Applications Ser. No. 10/323,623 (Attorney Docket No. 38187-2607) filed December 18, 2002; and commonly assigned copending U.S. Patent Applications Ser. No. 10/323,624 (Attorney Docket No. 38187-2608) filed December 18, 2002. This application is also related to commonly assigned copending U.S. Patent Applications Ser. Nos. 10/335,142, 10/335,215, 10/335,258, 10/335,099, 10/335,219, 10/335,052, 10/335,073, 10/335,220, 10/335,252, 10/335,218, 10/335,211, 10/335,257, 10/335,217, 10/335,212, and 10/335,241, 10/335,183, (Attorney Docket Nos. 38187-2633 through 38187-2652) filed December 31, 2002. This application is also a continuation-in-part of commonly assigned, copending U.S. Patent Application Ser. No. 10/425,815 (Attorney Docket No. 38187-2663) filed May 30, 2003. This application is a continuation-in-part of commonly assigned, copending U.S. Patent Application Ser. No. 10/323,622 (Attorney Docket No. 38187-2606) filed on December 18, 2002, which is a continuation-in-part of commonly assigned, copending U.S. Patent Application Ser. No. 10/127,395 (Attorney Docket No. 38187-2551) filed April 19, 2002. This application is also a continuation-in-part of commonly assigned, copending U.S. Patent Application Ser. No. 10/237,261 (Attorney Docket No. 38187-2595) filed September 5, 2002. This application is further a continuation-in-part of commonly assigned, copending U.S. Patent Application Ser. No. 10/420,535 (Attorney Docket No. 38187-2664) filed April 21, 2003. This application is further a continuation-in-part of commonly assigned, copending U.S. Patent Application Ser. No. 10/335,142 (Attorney Docket No. 38187-2633) filed December 31, 2002. This application is further a continuation-in-part of commonly assigned, copending U.S.

Patent Application Ser. No. 10/423,851 filed April 24, 2003. This application also claims the benefit of priority from commonly assigned, copending U.S. Provisional Patent Application Ser. No. 60/422,988 filed November 1, 2002; commonly assigned, copending U.S. Provisional Patent Application Ser. No. 60/424,429 filed November 6, 2002; and commonly assigned, copending U.S. Provisional Patent Application Ser. No. 60/424,429 filed November 20, 2002. U.S. Provisional Patent Applications Ser. No. 60/494,417, 60/494,401.

[0219] The publications discussed or cited herein are provided solely for their disclosure prior to the filing date of the present application. Nothing herein is to be construed as an admission that the present invention is not entitled to antedate such publication by virtue of prior invention. Further, the dates of publication provided may be different from the actual publication dates which may need to be independently confirmed.

[0220] Expected variations or differences in the results are contemplated in accordance with the objects and practices of the present invention. It is intended, therefore, that the invention be defined by the scope of the claims which follow and that such claims be interpreted as broadly as is reasonable.

Claims

1. A body fluid sampling device comprising:

a first cartridge (1310) containing a plurality of penetrating members (1312) having sharpened distal ends (12) pointed radially out from a center point of the cartridge;

a second cartridge (1318) having a plurality of analyte detecting members (1326) and coupled to said first cartridge, wherein said analyte detecting members comprise contact electrodes (1296) arranged about an exit port (1297) for each of the penetrating members

wherein said analyte detecting members on said second cartridge are positioned to receive body fluid for a wound created by one of said penetrating members exiting said first cartridge.

2. The device of claim 1 wherein said first cartridge comprises a radial cartridge.

3. The device of claim 1 wherein said second cartridge comprises a ring shaped cartridge.

4. The device of claim 1 wherein said first cartridge is integrally formed with the second cartridge.

5. The device of claim 1 wherein said second cartridge has more analyte detecting members than penetrating members in the first cartridge.

6. The device of claim 1, wherein each of the analyte detecting members includes at least three electrodes (1296).

7. The device of claim 1 wherein said first cartridge is adhered to the second cartridge.

8. A method comprising:

providing a first cartridge (1310) containing a plurality of penetrating members (1312) having sharpened distal ends (12) pointed radially out from a center point of the cartridge; sterilizing said penetrating members in said cartridge and providing a sterility barrier to maintain said sterile condition until use; and coupling a second cartridge (1318) to said first cartridge, wherein said second cartridge contains at least one analyte detecting member (1326) comprising contact electrodes (1296) arranged about an exit port (1297) for a penetrating member.

9. The method of claim 8 wherein said coupling comprises adhering the second cartridge to the first cartridge.

Patentansprüche

1. Gerät zur Entnahme von Körperflüssigkeit, umfassend:

ein erstes Magazin (1310) mit einer Vielzahl von durchdringenden Elemente (1312) mit geschärften distalen Enden (12), die radial von einem Mittelpunkt des Magazins nach außen zeigen,

ein zweites Magazin (1318) mit einer Vielzahl von Elementen zum Erfassen von Analyten (1326) und mit dem ersten Magazin verbunden, wobei die Elemente zum Erfassen von Analyten Kontaktelektroden (1296) umfassen, die für jedes der durchdringenden Elemente an einer Ausgangsöffnung (1297) angeordnet sind, wobei die Elemente zum Erfassen von Analyten an dem zweiten Magazin so angeordnet sind, dass sie von einer Wunde, die durch eines der durchdringenden Elemente, das aus dem ersten Magazin herauskommt, geschaffen wurde, Körperflüssigkeit entgegennehmen können.

2. Gerät nach Anspruch 1, wobei das erste Magazin ein radiales Magazin umfasst.

3. Gerät nach Anspruch 1, wobei das zweite Magazin ein ringförmiges Magazin umfasst.

4. Gerät nach Anspruch 1, wobei das erste Magazin mit dem zweiten Magazin integral ausgebildet ist.
5. Gerät nach Anspruch 1, wobei das zweite Magazin mehr Elemente zum Erfassen von Analyten als durchdringende Elemente in dem ersten Magazin umfasst.
6. Gerät nach Anspruch 1, wobei jedes der Elemente zum Erfassen von Analyten wenigstens drei Elektroden (1296) umfasst.
7. Gerät nach Anspruch 1, wobei das erste Magazin an das zweite Magazin geklebt ist.
8. Verfahren, das umfassend:

Bereitstellen eines ersten Magazins (1310) mit einer Vielzahl von durchdringenden Elementen (1312) mit geschärften distalen Enden (12), die radial von einem Mittelpunkt des Magazins nach außen zeigen,
Sterilisieren der durchdringenden Elemente in dem Magazin und Bereitstellen einer sterilen Barriere, um diesen sterilen Zustand bis zum Verwenden aufrechtzuerhalten, und
Verbinden eines zweiten Magazins (1318) mit erster Magazin, wobei das zweite Magazin wenigstens ein Element zum Erfassen von Analyten (1326) enthält, das Kontaktelektroden (1296) umfasst, die an einer Ausgangsöffnung (1297) für ein durchdringendes Element angeordnet sind.

9. Verfahren nach Anspruch 8, wobei das Verbinden das Ankleben des zweiten Magazins an das erste Magazin umfasst.

Revendications

1. Dispositif d'échantillonnage de fluide corporel comprenant :

une première cartouche (1310) contenant une pluralité d'éléments pénétrants (1312) comportant des extrémités distales (12) pointues dirigées radialement vers l'extérieur à partir d'un point central de la cartouche ;
une deuxième cartouche (1318) comportant une pluralité d'éléments de détection de substance à analyser (1326) et accouplée à ladite première cartouche, dans lequel lesdits éléments de détection de substance à analyser comprennent des électrodes de contact (1296) agencées autour d'un orifice de sortie (1297) pour chacun des éléments pénétrants ;
dans lequel lesdits éléments de détection de

substance à analyser sur ladite deuxième cartouche sont positionnés pour recevoir un fluide corporel pour une blessure créée par l'un desdits éléments pénétrants sortant de ladite première cartouche.

2. Dispositif selon la revendication 1, dans lequel ladite première cartouche comprend une cartouche radiale.
3. Dispositif selon la revendication 1, dans lequel ladite deuxième cartouche comprend une cartouche de forme annulaire.
4. Dispositif selon la revendication 1, dans lequel ladite première cartouche est formée d'un seul tenant avec la deuxième cartouche.
5. Dispositif selon la revendication 1, dans lequel le nombre d'éléments de détection de substance à analyser dans ladite deuxième cartouche est supérieur au nombre d'éléments pénétrants dans la première cartouche.
6. Dispositif selon la revendication 1, dans lequel chacun des éléments de détection de substance à analyser comprend au moins trois électrodes (1296).
7. Dispositif selon la revendication 1, dans lequel ladite première cartouche est collée à la deuxième cartouche.
8. Procédé comprenant :
- la fourniture d'une première cartouche (1310) contenant une pluralité d'éléments pénétrants (1312) comportant des extrémités distales (12) pointues dirigées radialement vers l'extérieur à partir d'un point central de la cartouche ;
la stérilisation desdits éléments pénétrants dans ladite cartouche et la prévision d'une barrière de stérilité pour maintenir ladite condition stérile jusqu'à l'utilisation ; et
l'accouplement d'une deuxième cartouche (1318) à ladite première cartouche, dans lequel ladite deuxième cartouche contient au moins un élément de détection de substance à analyser (1326) comprenant des électrodes de contact (1296) agencées autour d'un orifice de sortie (1297) pour un élément pénétrant.
9. Procédé selon la revendication 8, dans lequel ledit accouplement comprend le collage de la deuxième cartouche à la première cartouche.

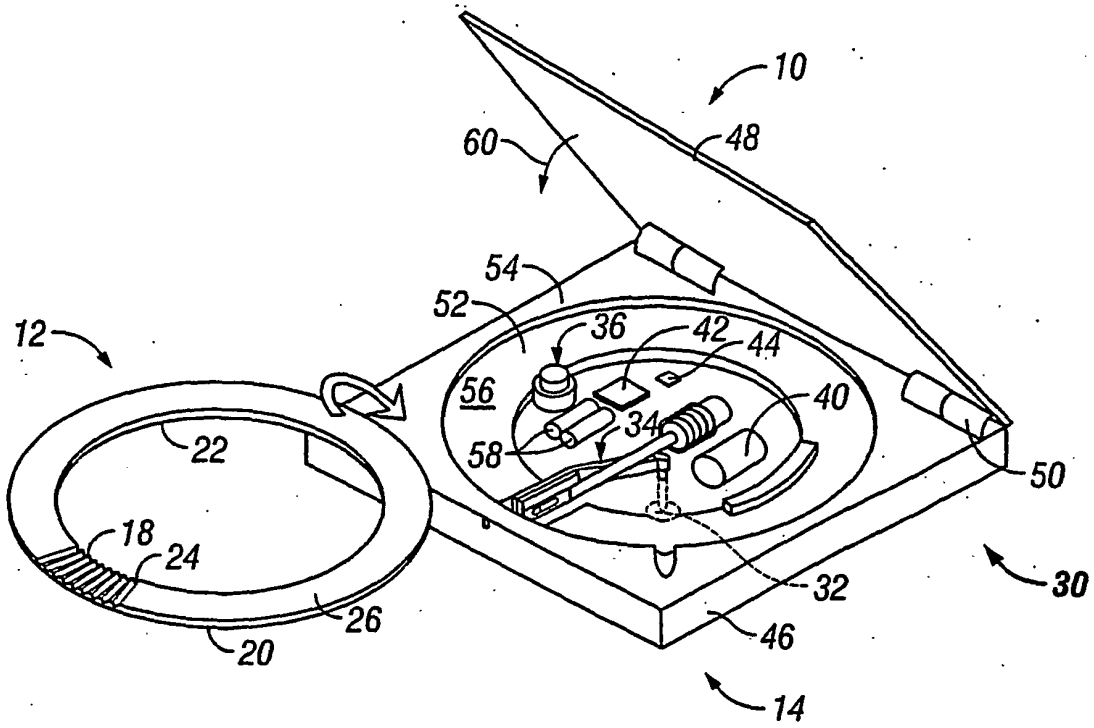


FIG. 1

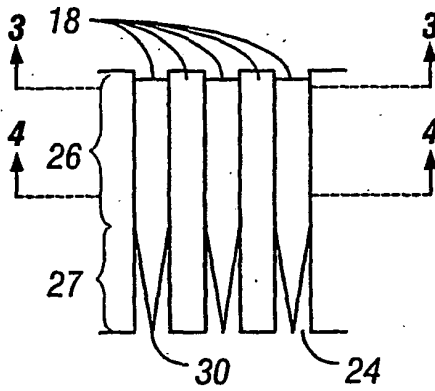


FIG. 2

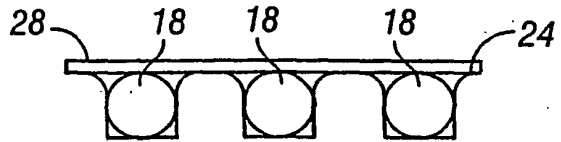


FIG. 3

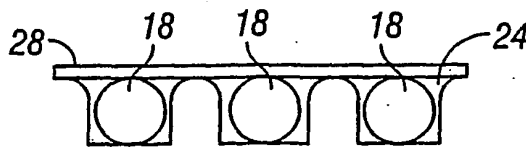


FIG. 4

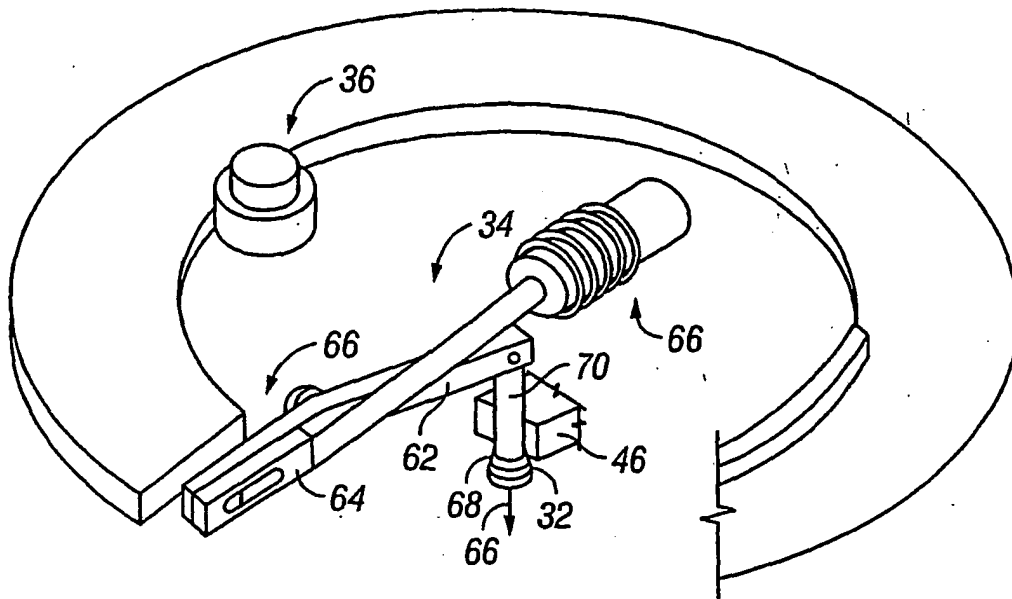


FIG. 5

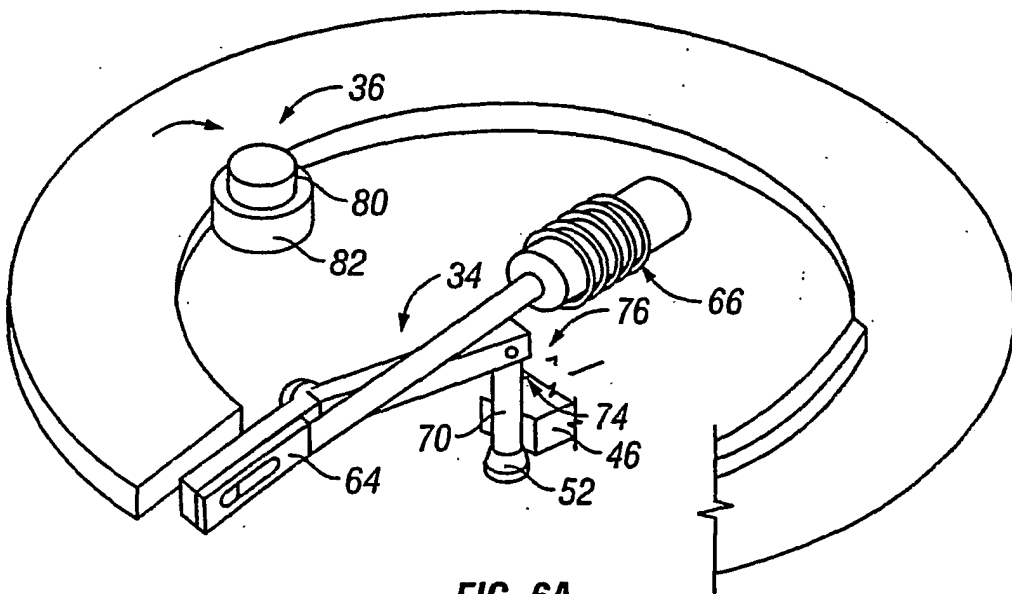


FIG. 6A

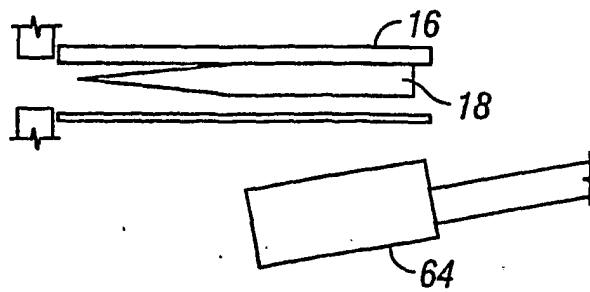


FIG. 6B

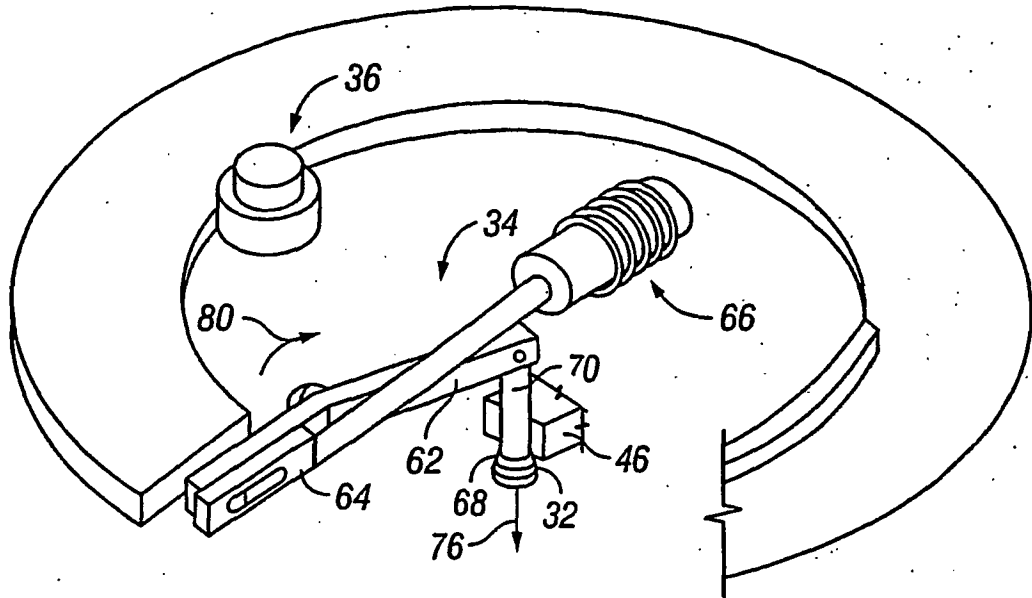


FIG. 7A

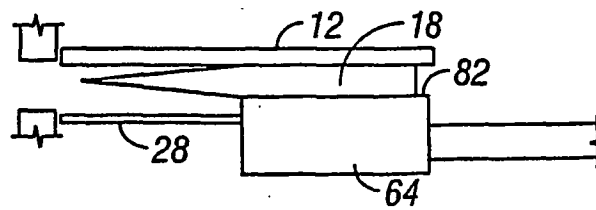


FIG. 7B

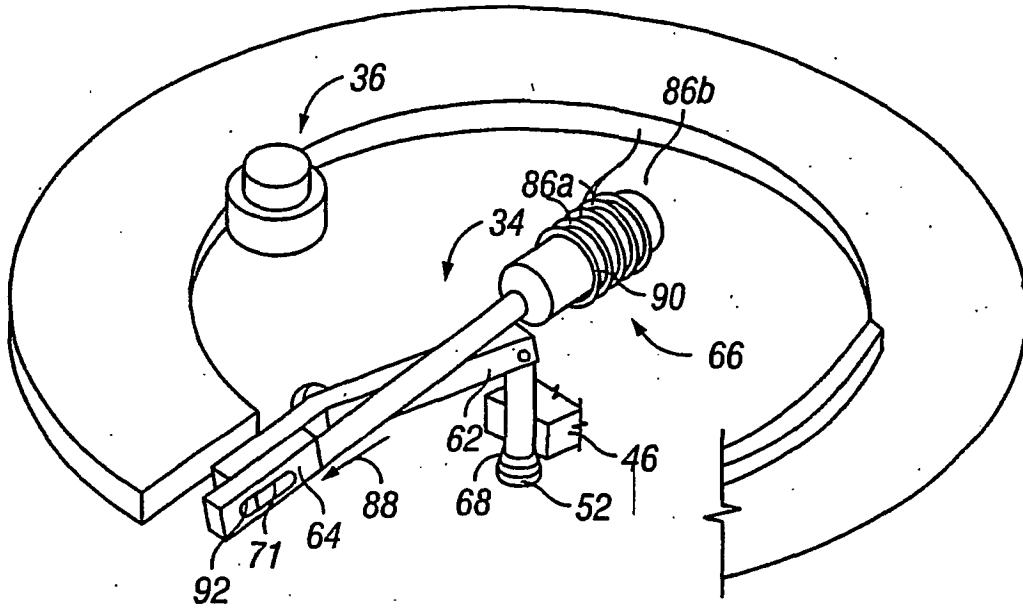


FIG. 8A

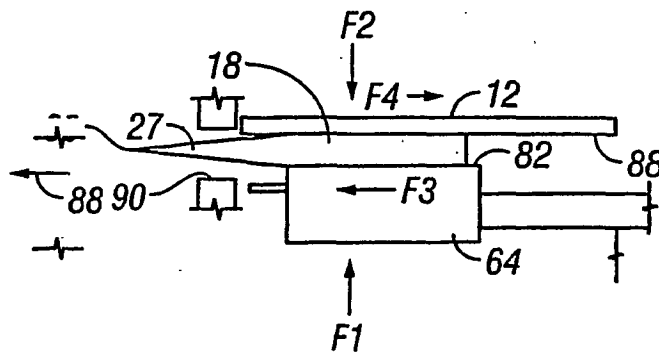


FIG. 8B

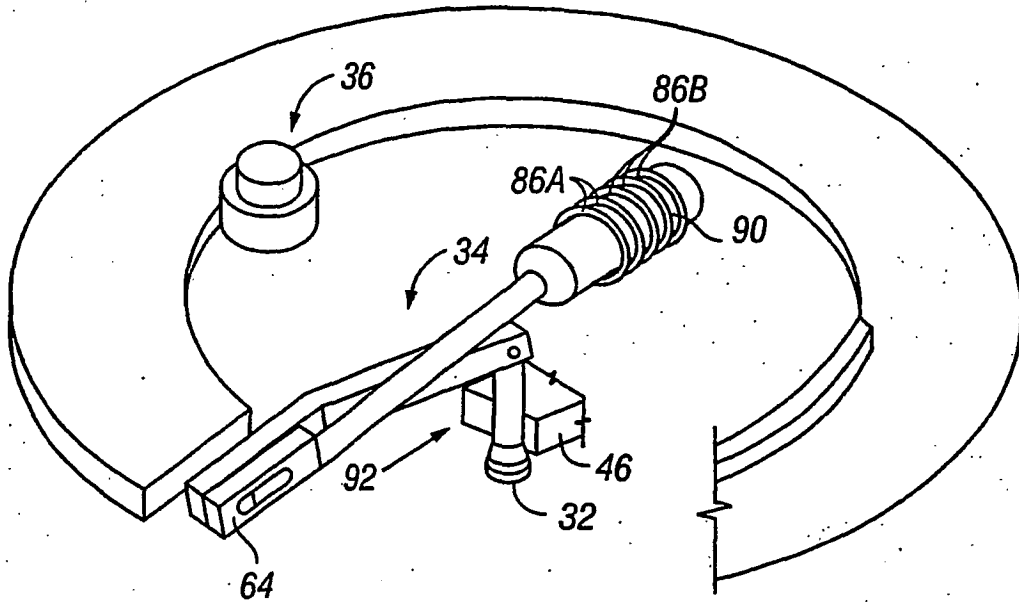


FIG. 9A

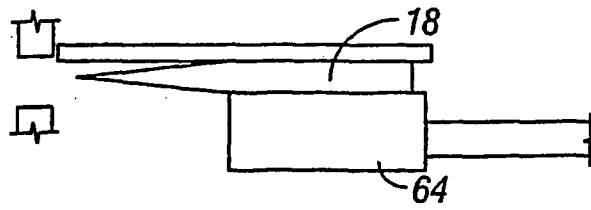


FIG. 9B

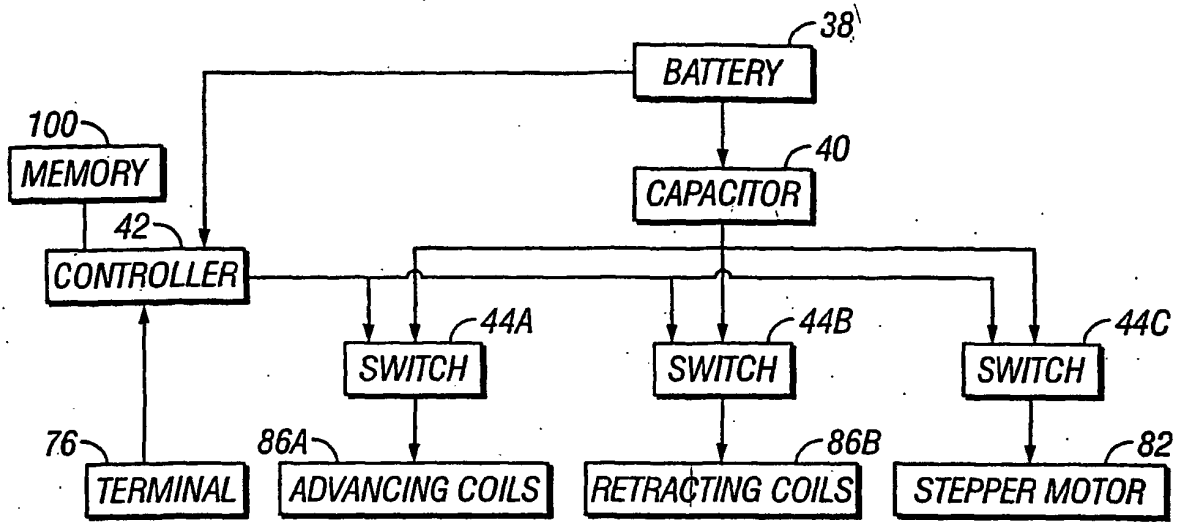


FIG. 10

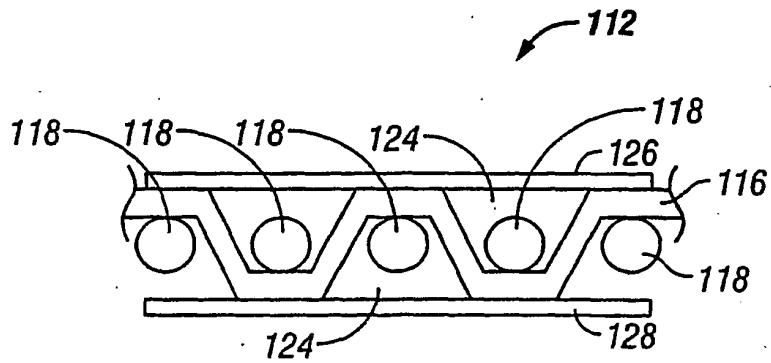


FIG. 11

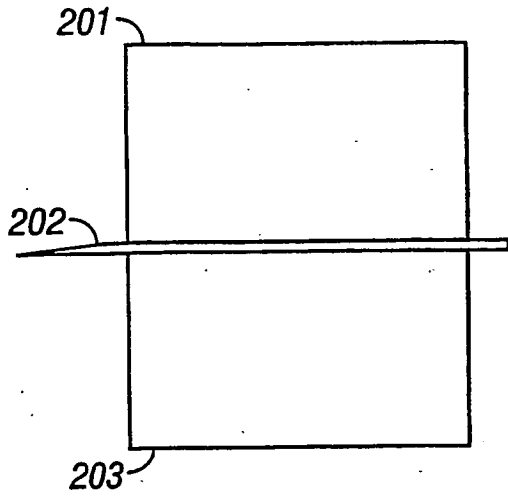


FIG. 12

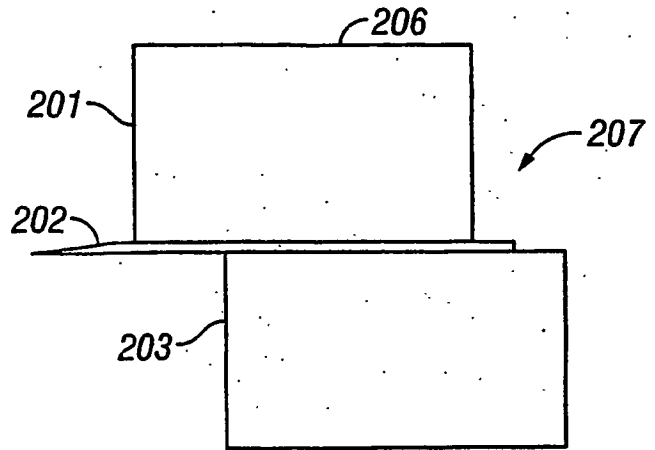


FIG. 13

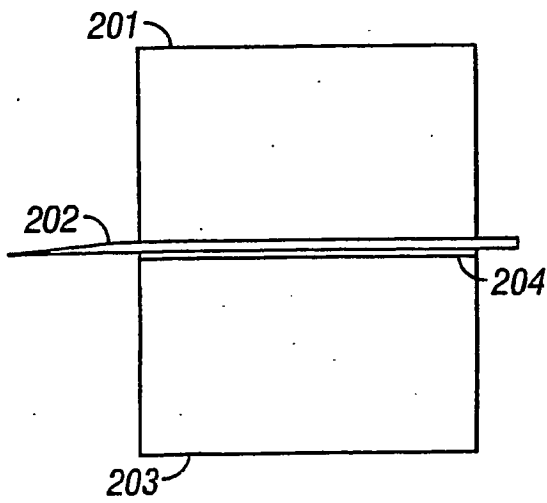


FIG. 14

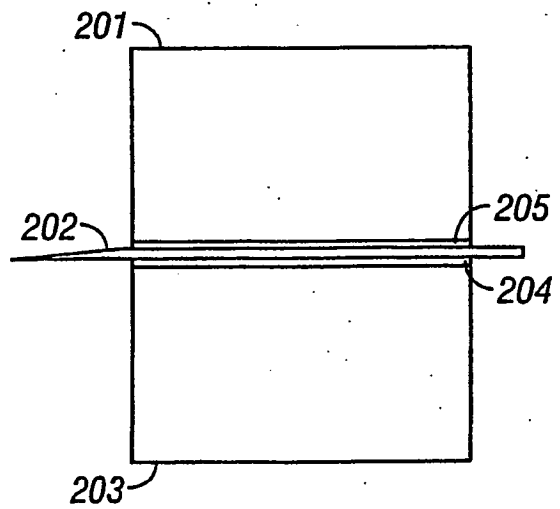


FIG. 15

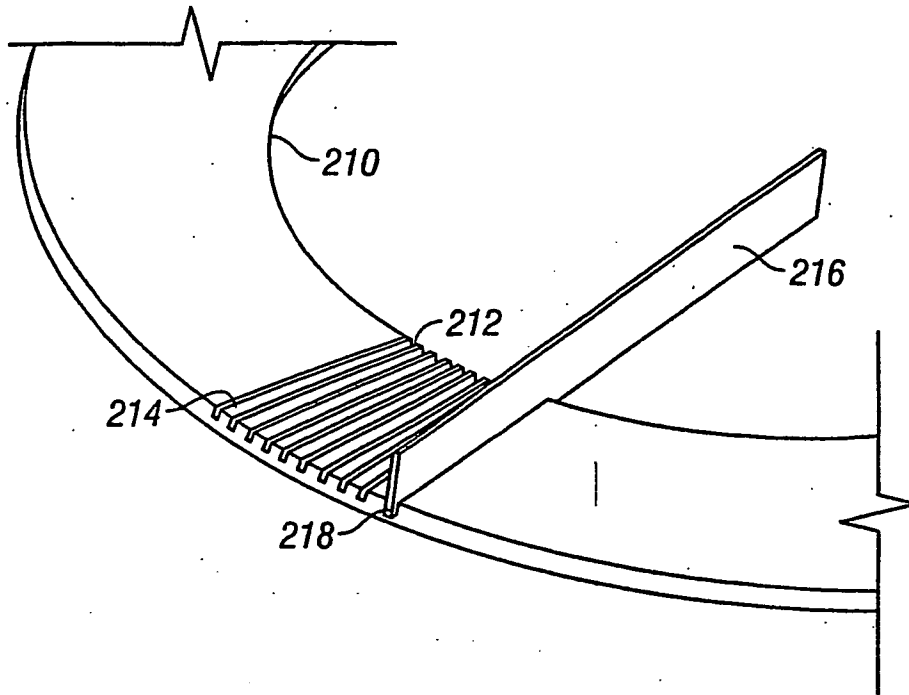


FIG. 16

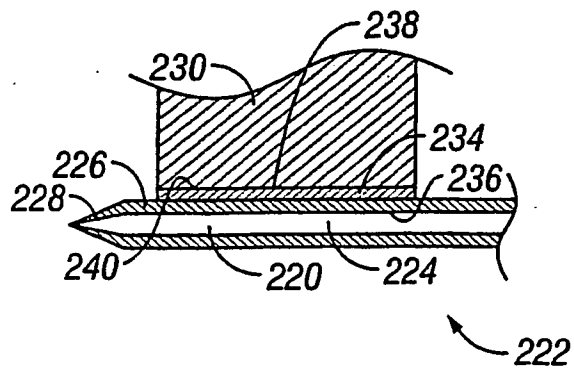


FIG. 17

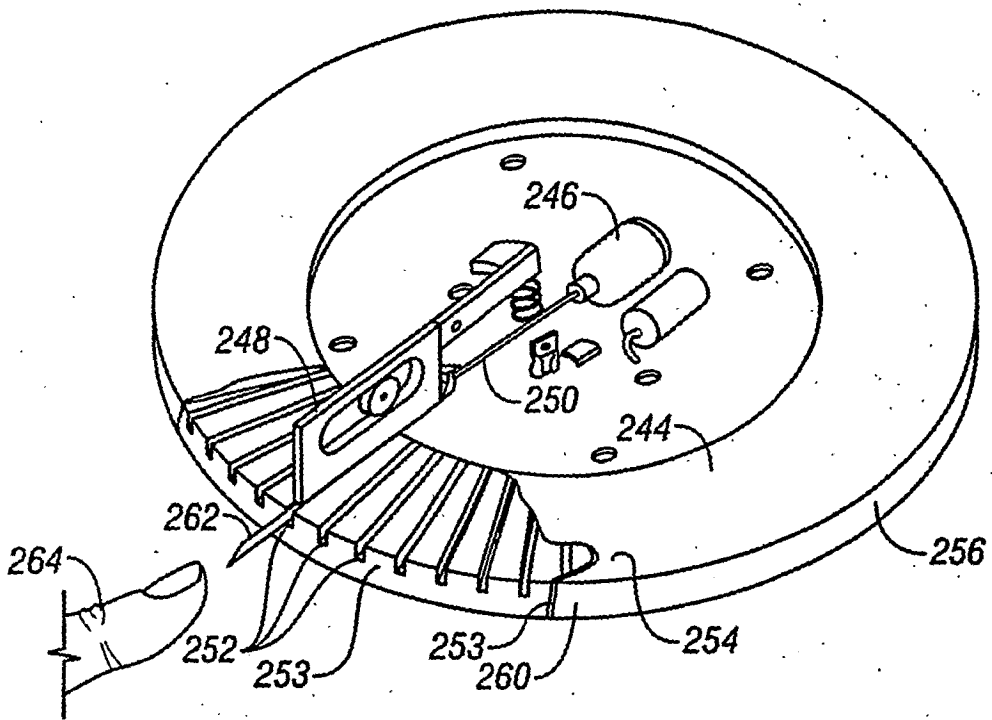


FIG. 18

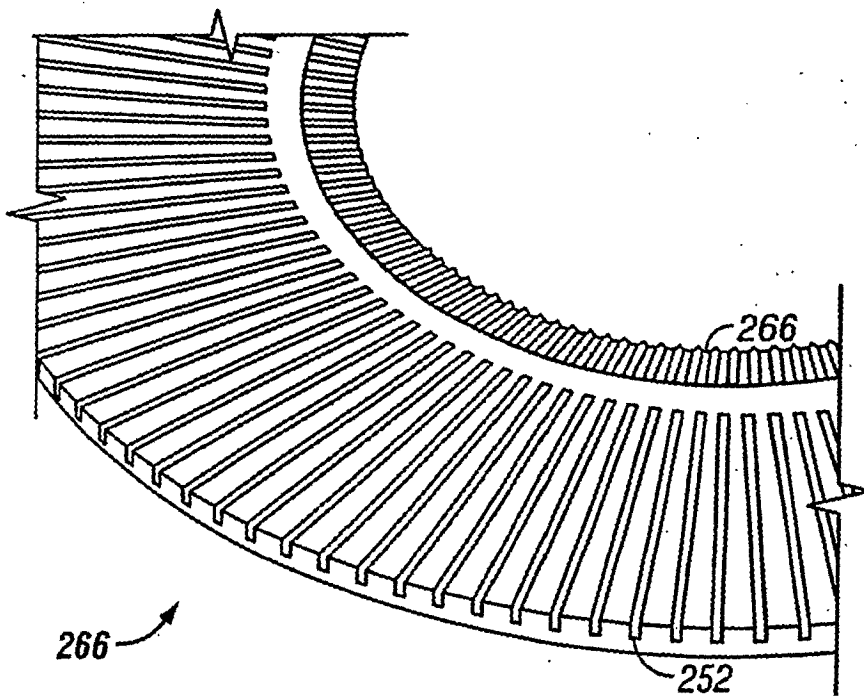


FIG. 19

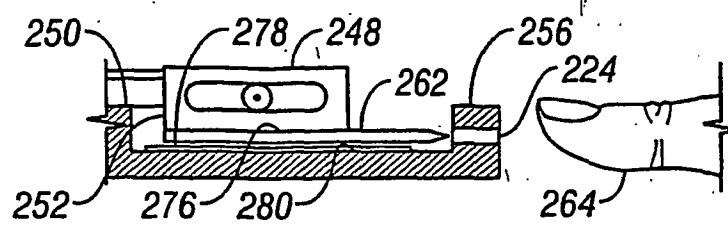


FIG. 20

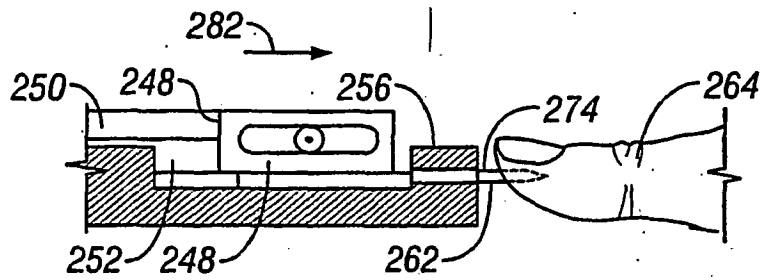


FIG. 21

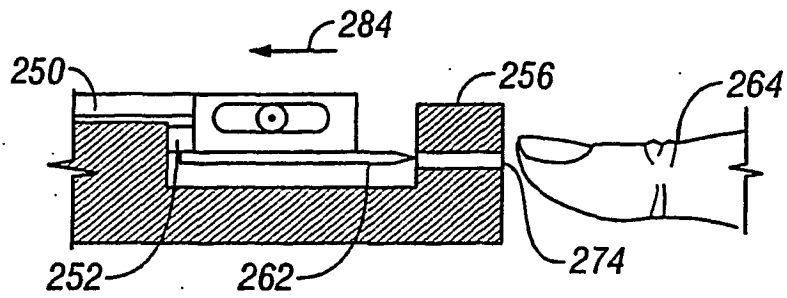


FIG. 22

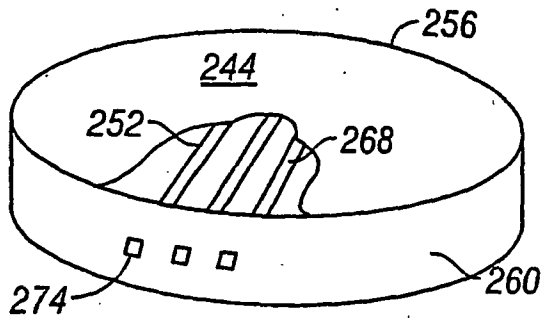


FIG. 23

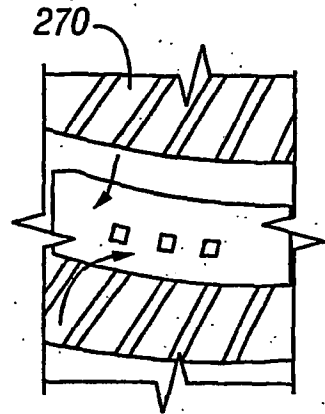


FIG. 24

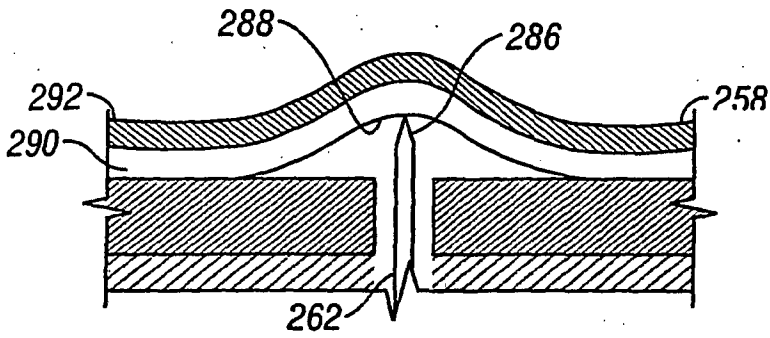


FIG. 25

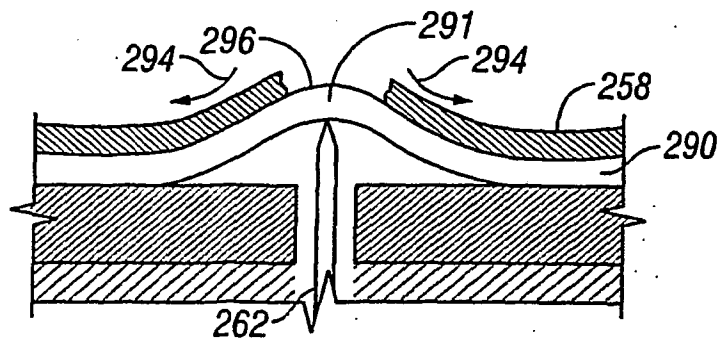


FIG. 26

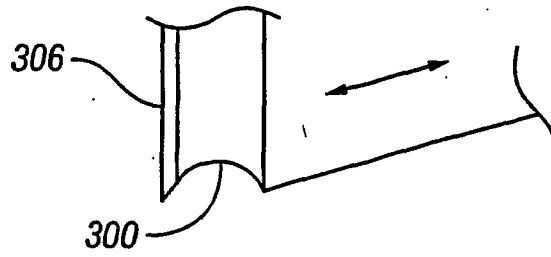


FIG. 27

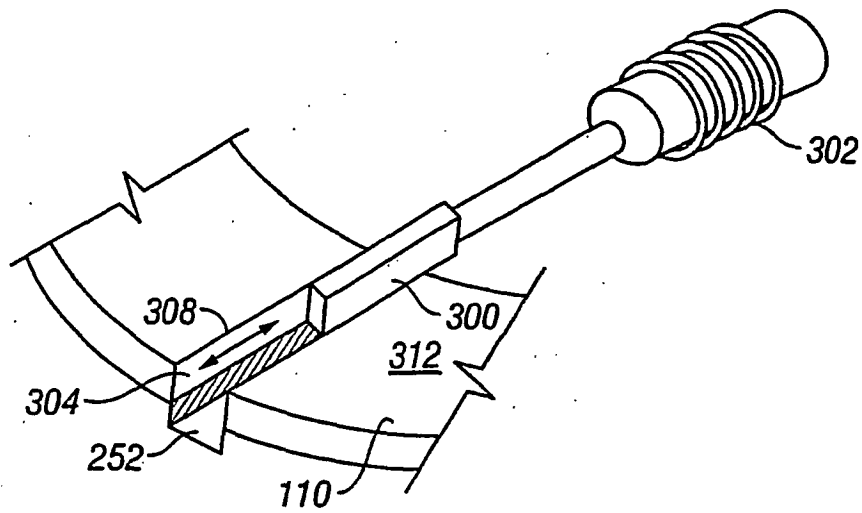


FIG. 28

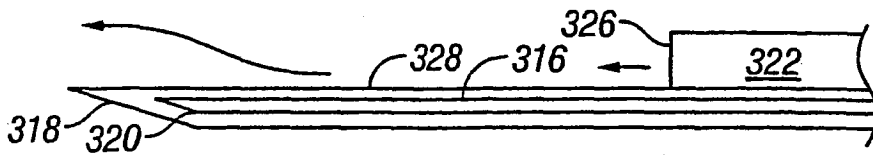


FIG. 29

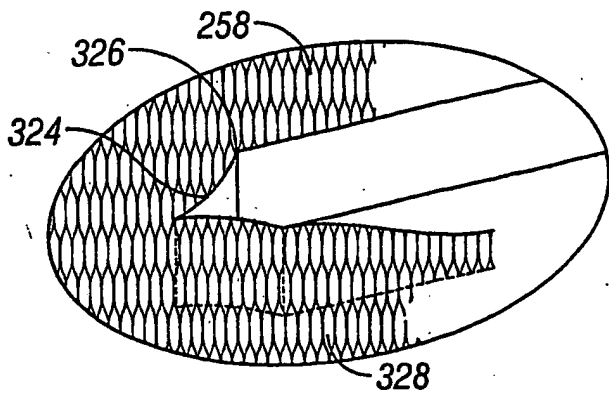


FIG. 30

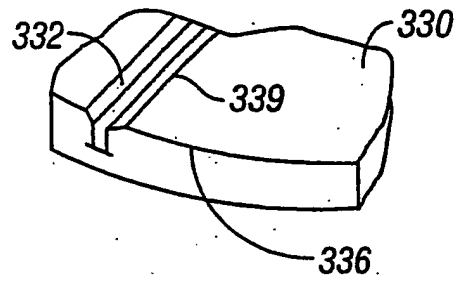


FIG. 31

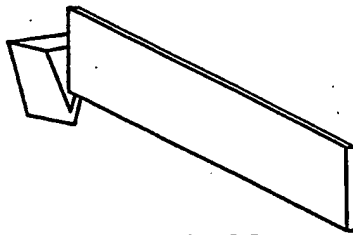


FIG. 32

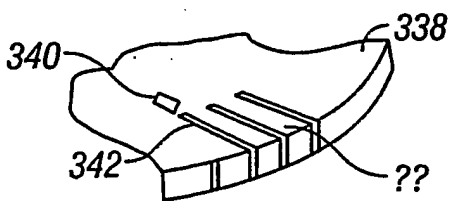


FIG. 33

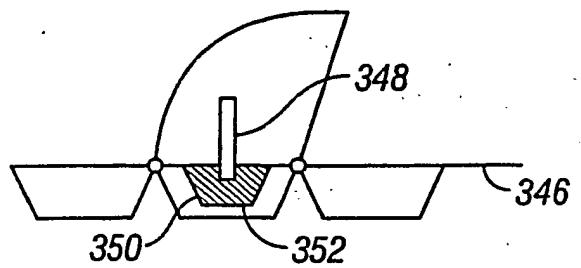


FIG. 34

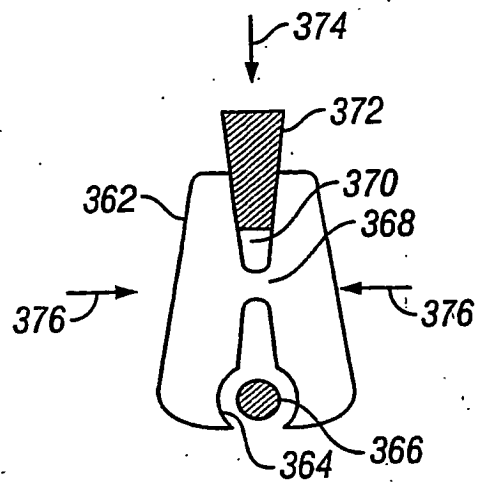


FIG. 35

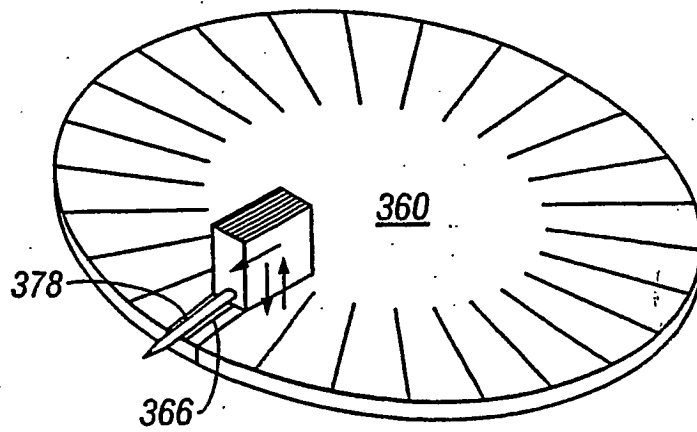


FIG. 36

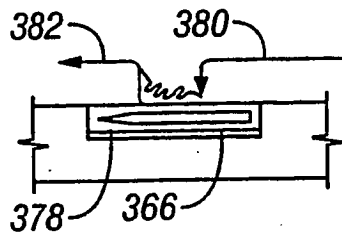


FIG. 37

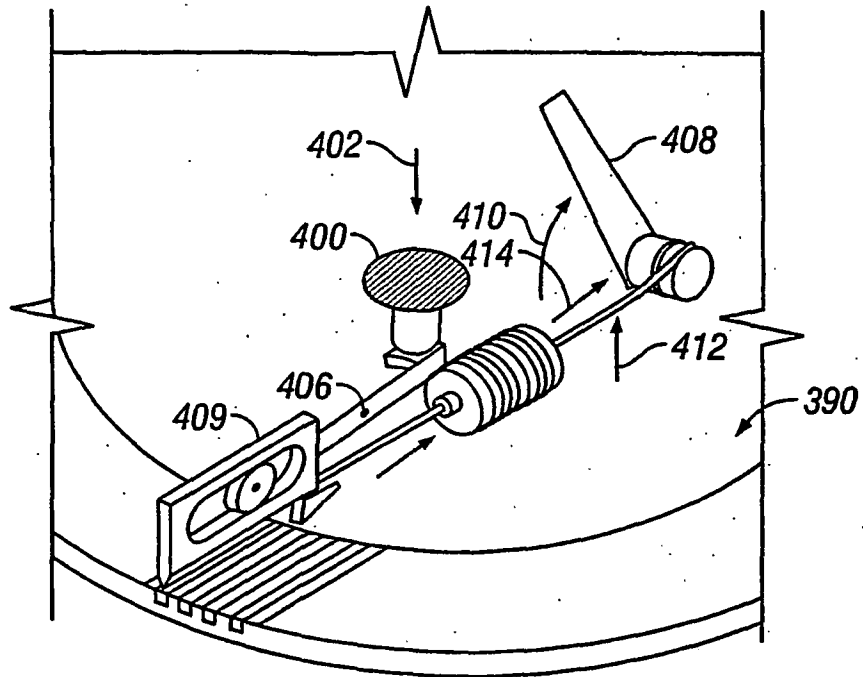


FIG. 38

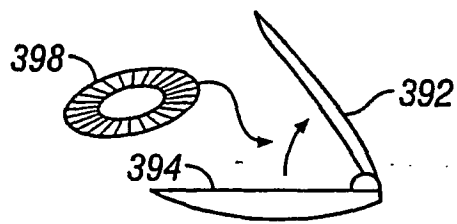


FIG. 39

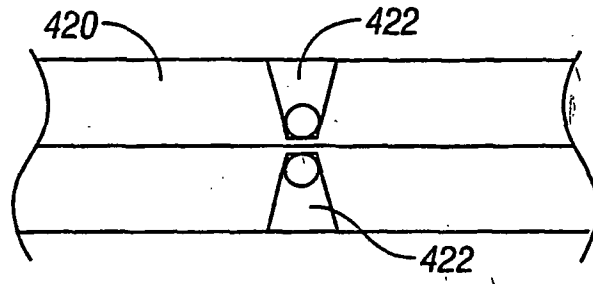


FIG. 40

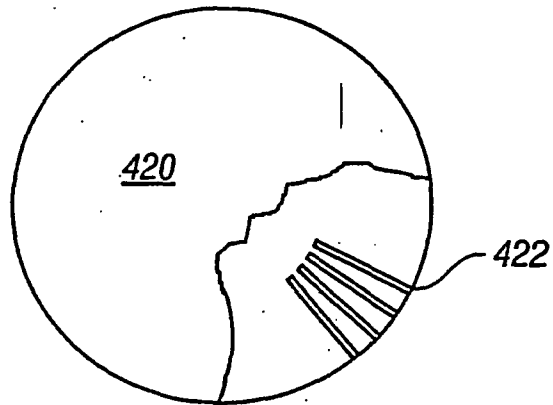


FIG. 41

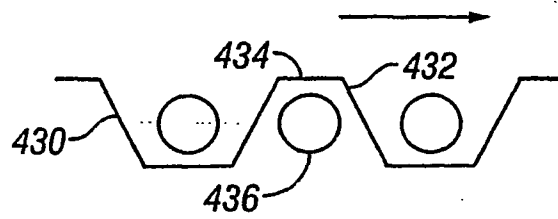


FIG. 42

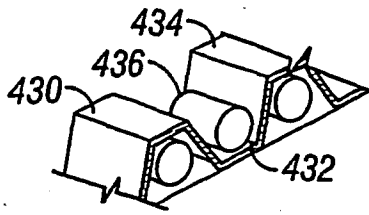


FIG. 43

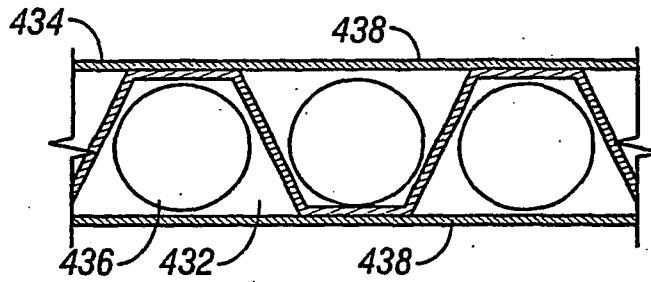


FIG. 44

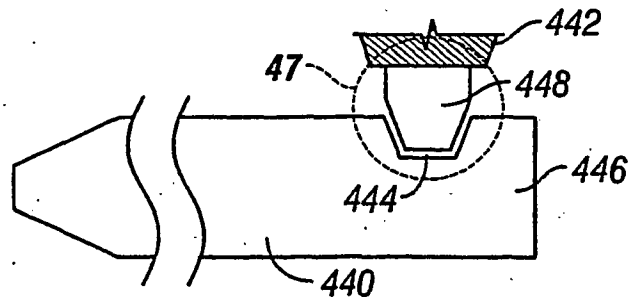


FIG. 45

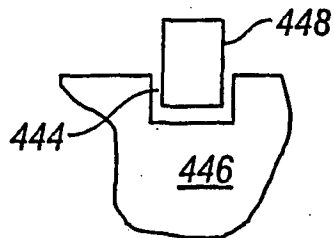


FIG. 46

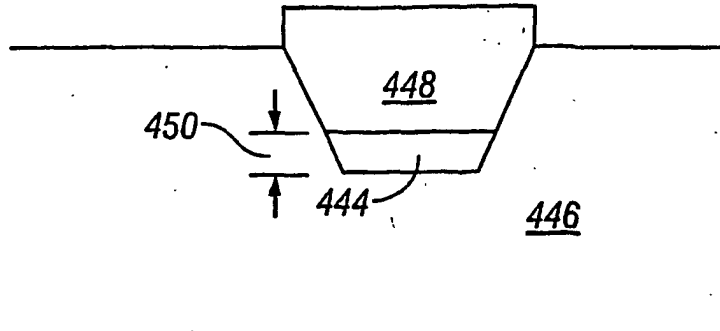


FIG. 47

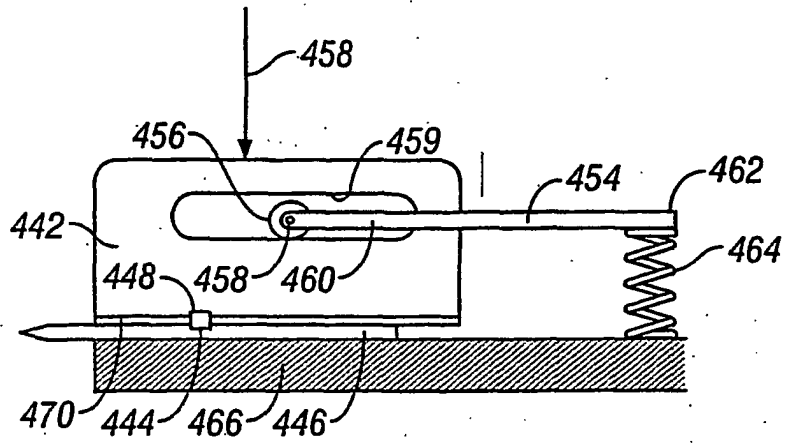


FIG. 48

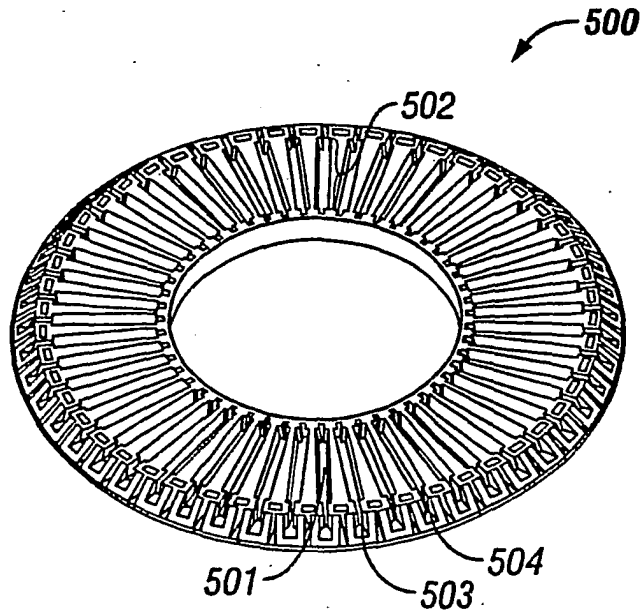


FIG. 49

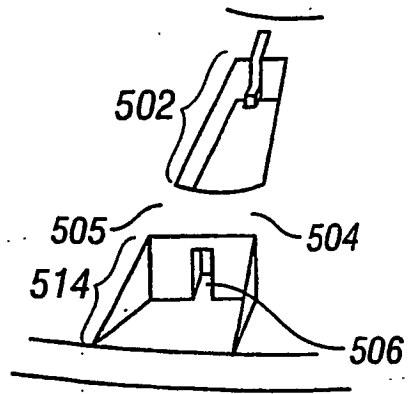


FIG. 50

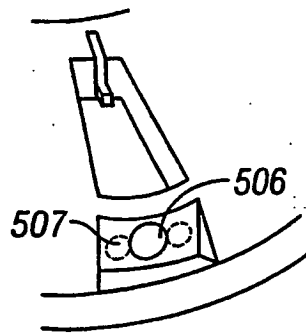


FIG. 51

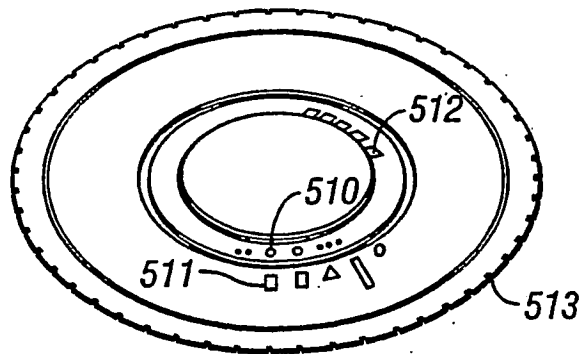


FIG. 52

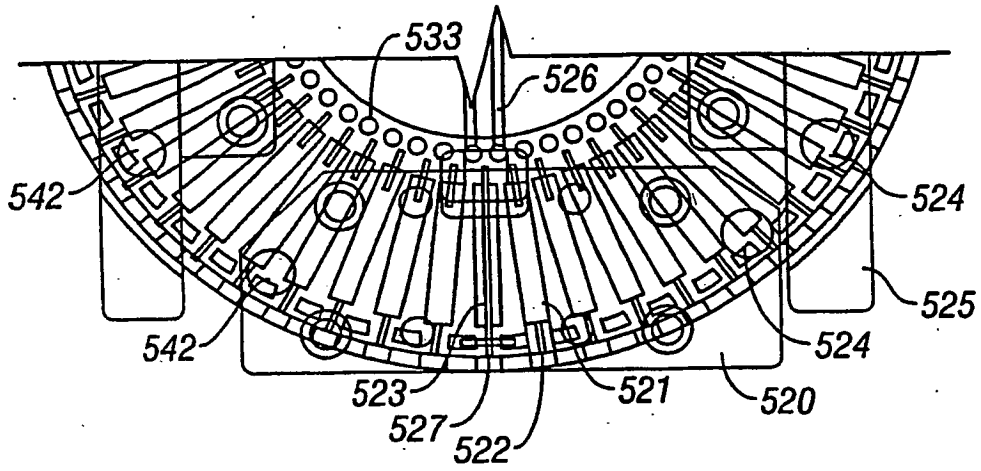


FIG. 53A

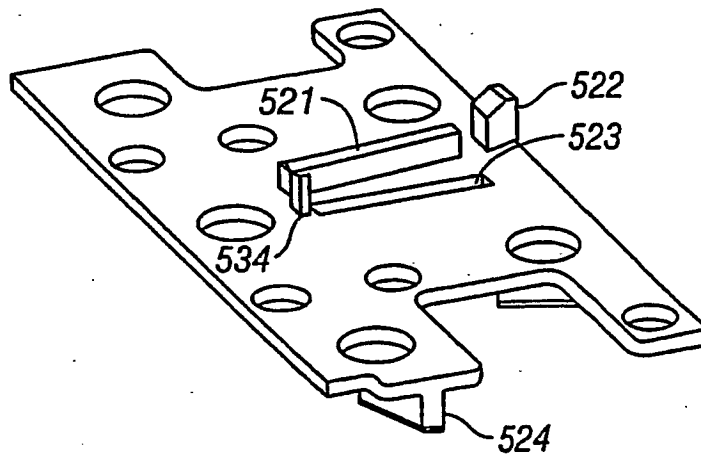


FIG. 53B

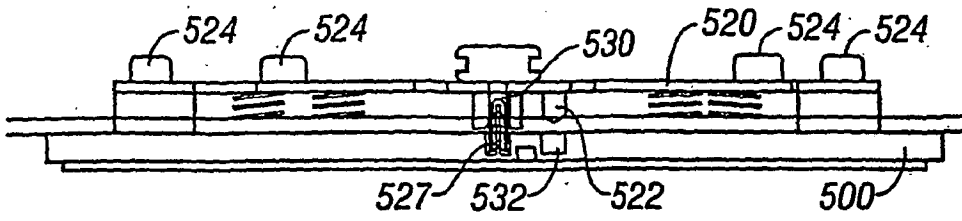


FIG. 54A

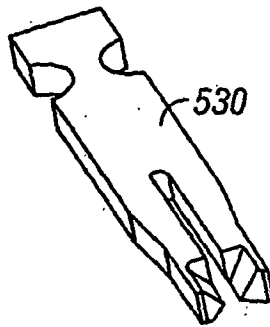


FIG. 54B

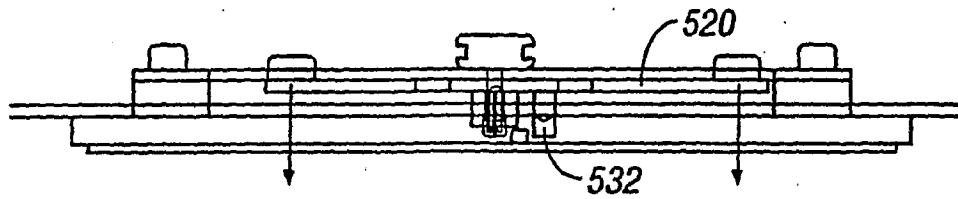


FIG. 54C

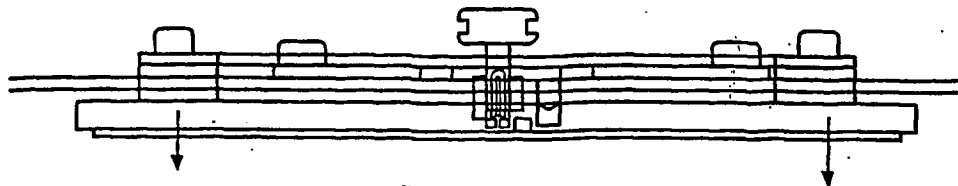


FIG. 54D

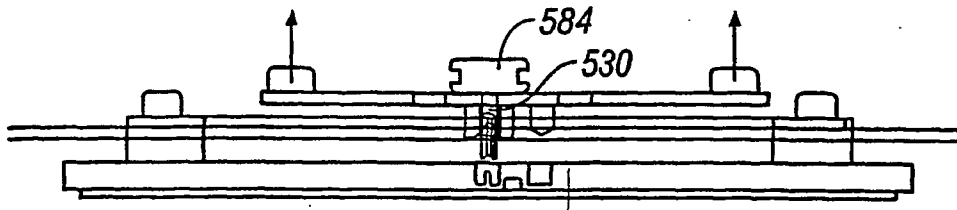


FIG. 54E

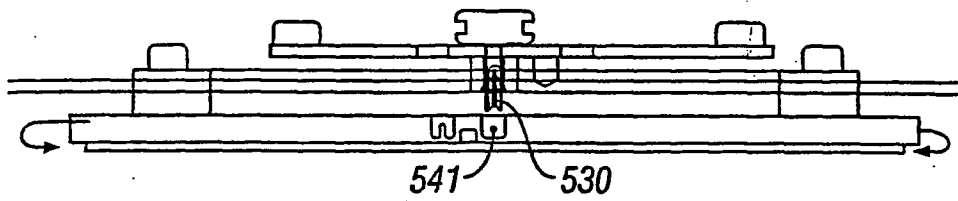


FIG. 54F

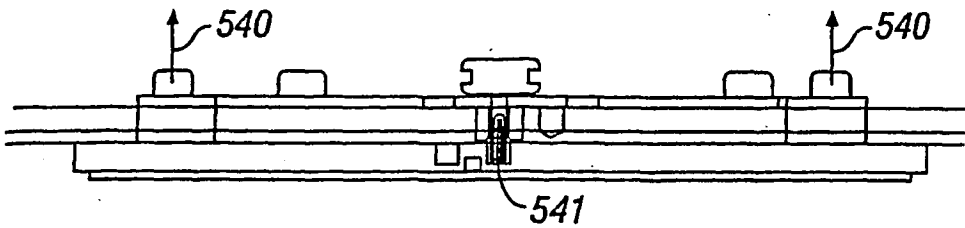


FIG. 54G

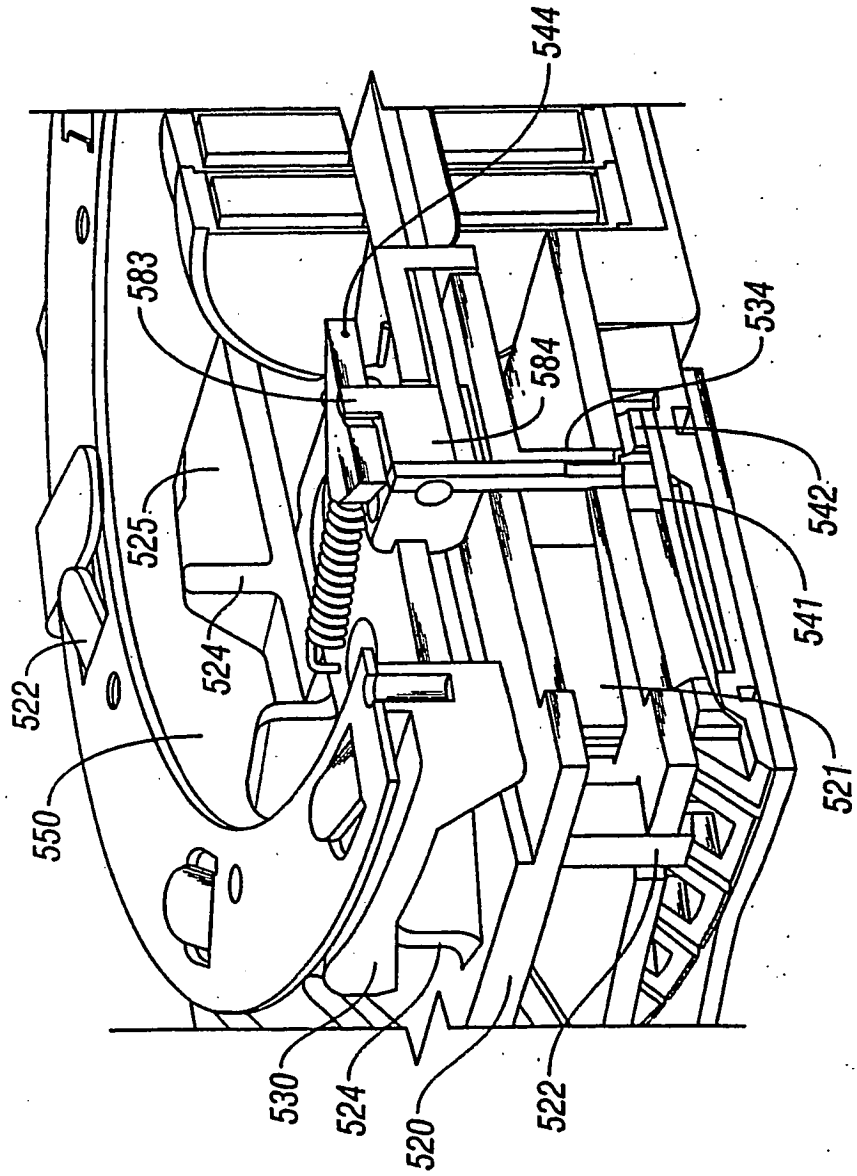


FIG. 55A

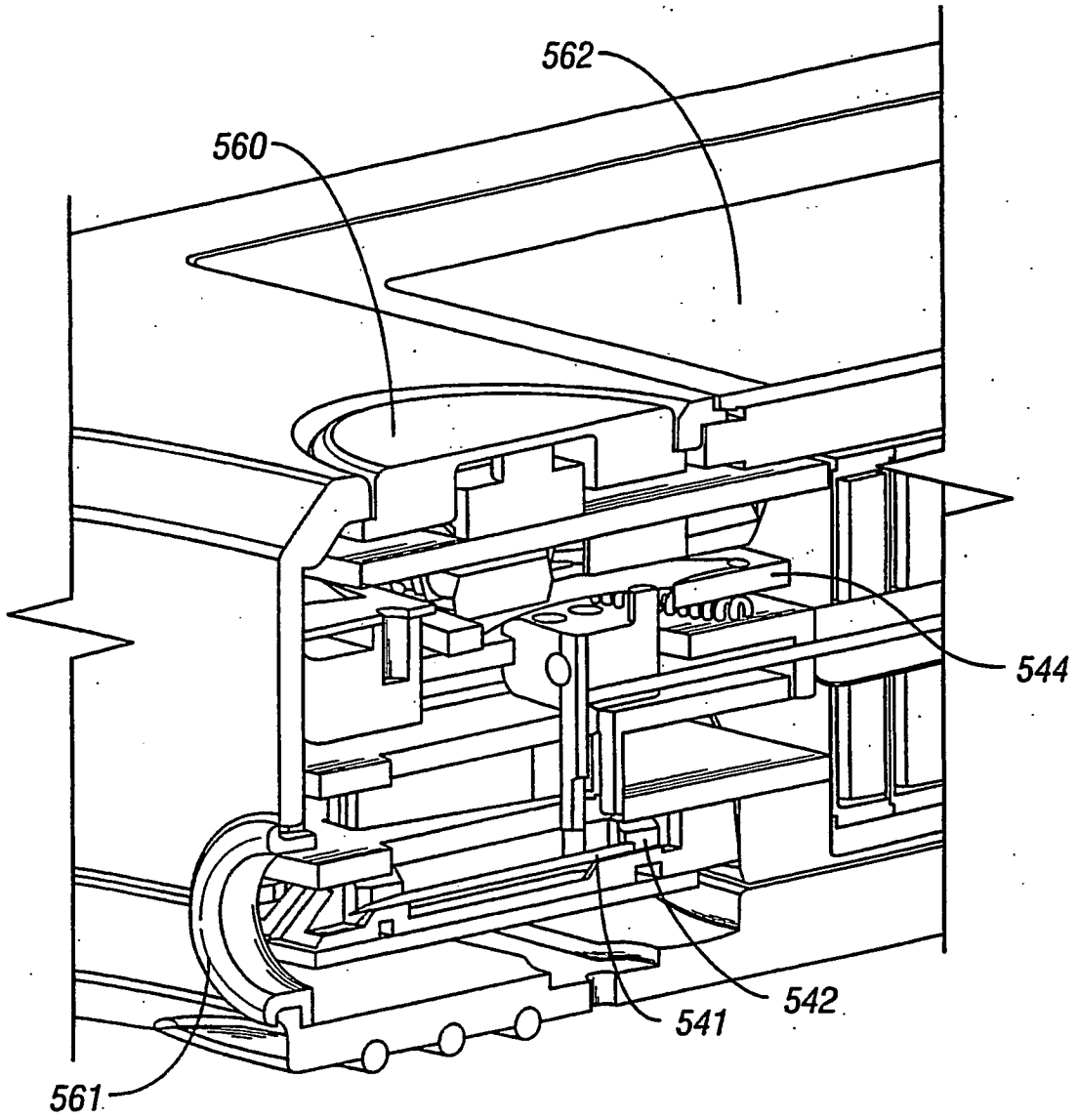


FIG. 55B

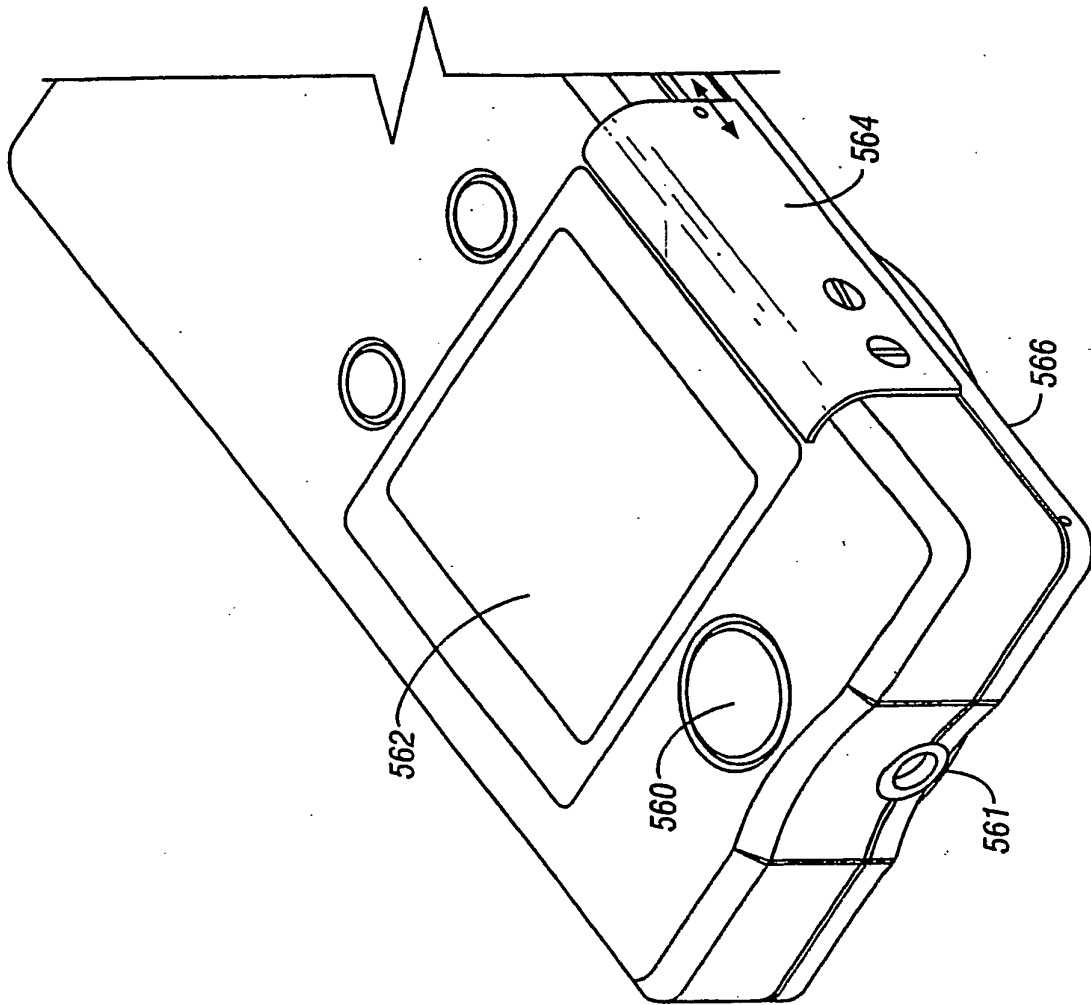


FIG. 56A

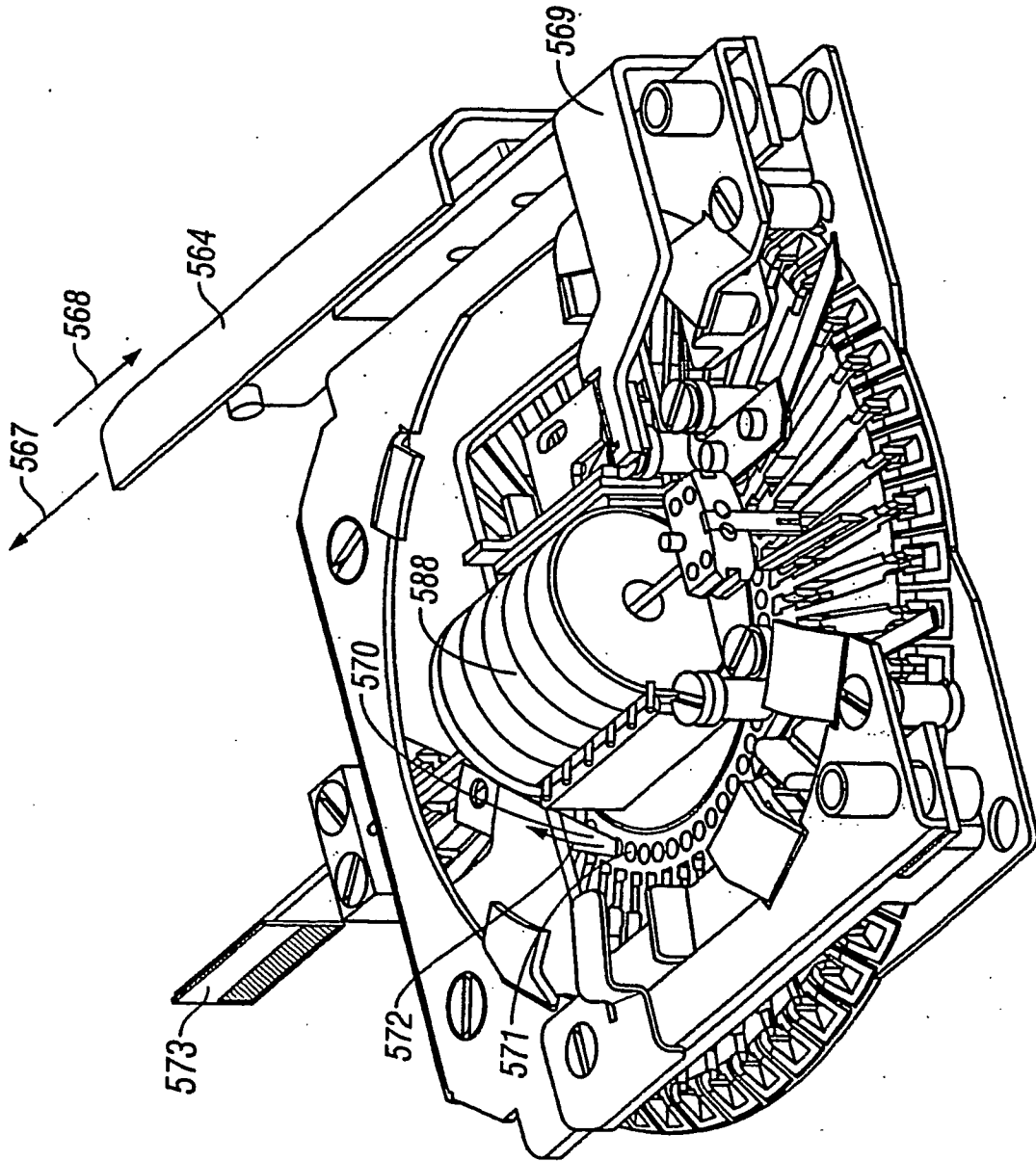


FIG. 56B

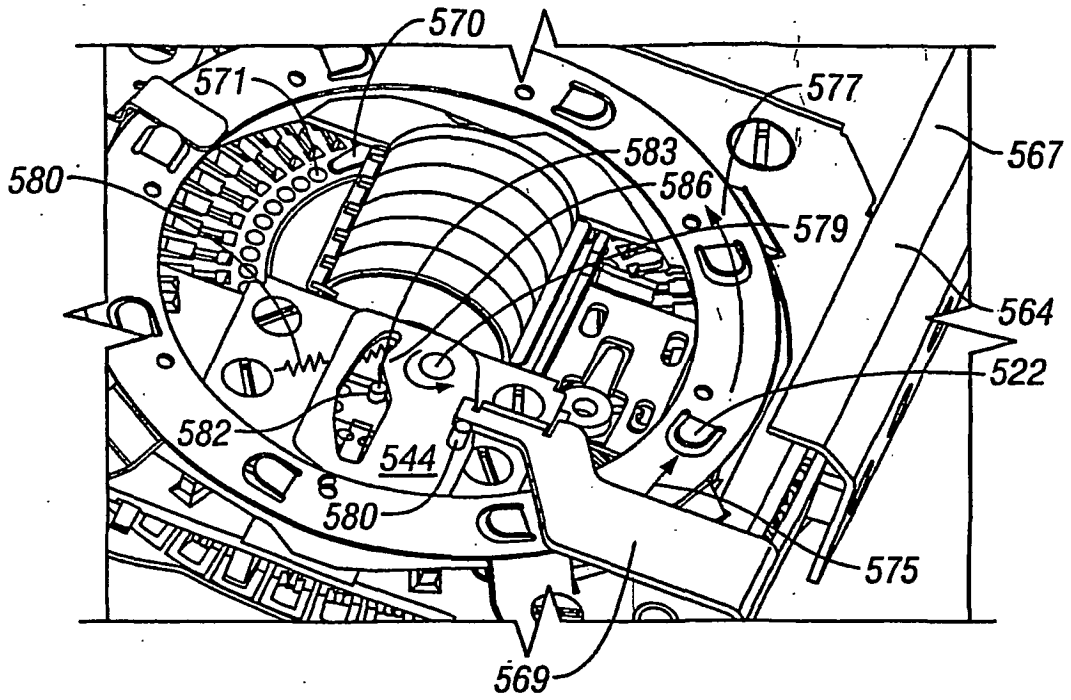


FIG. 56C

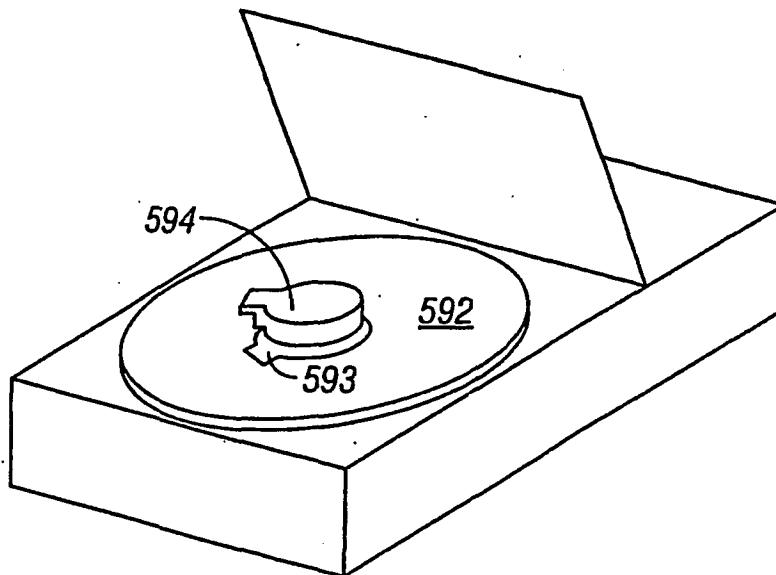


FIG. 56D

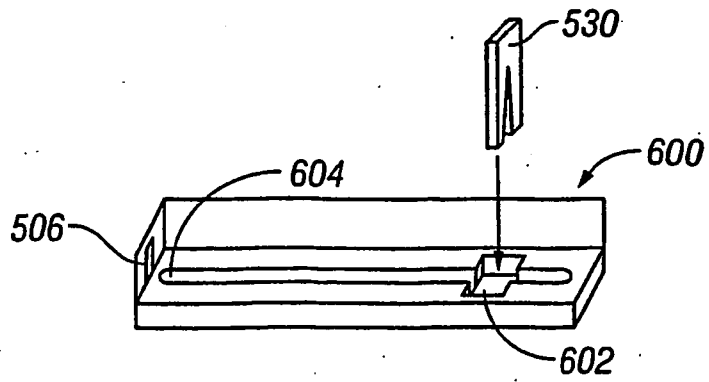


FIG. 57

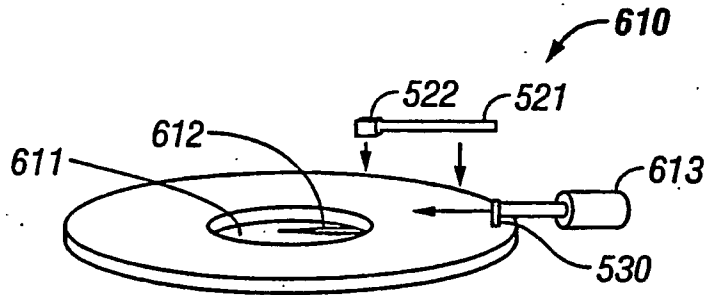


FIG. 58

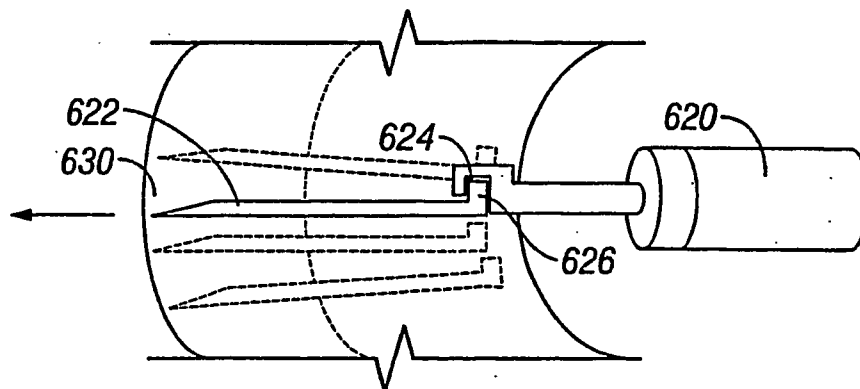


FIG. 59

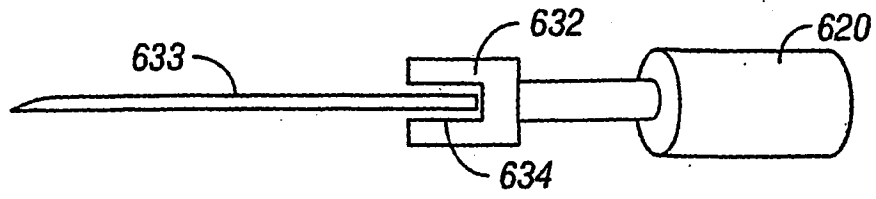


FIG. 60A

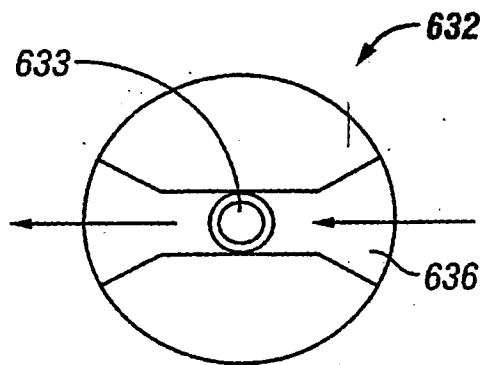


FIG. 60B

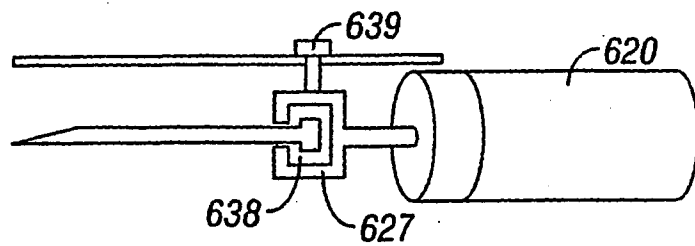


FIG. 60C

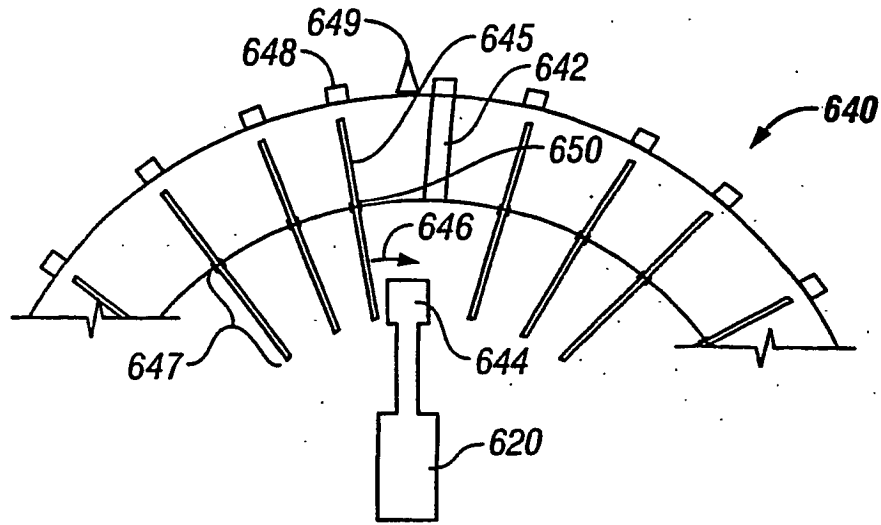


FIG. 61

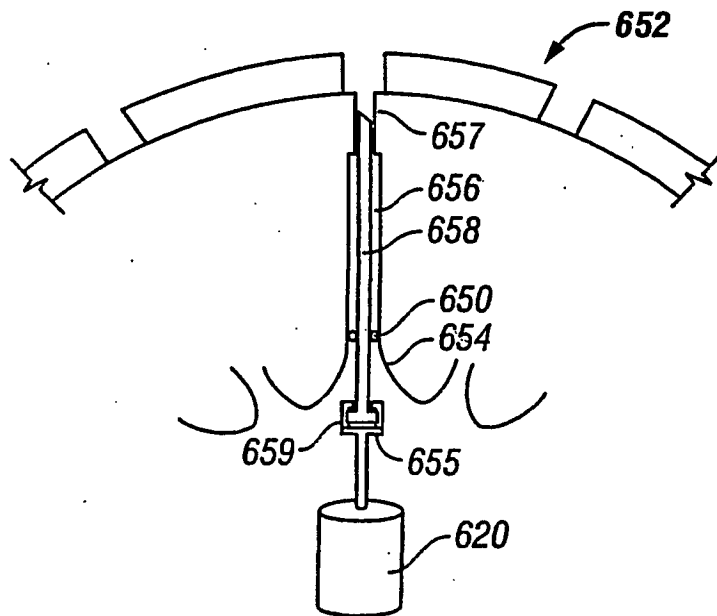


FIG. 62

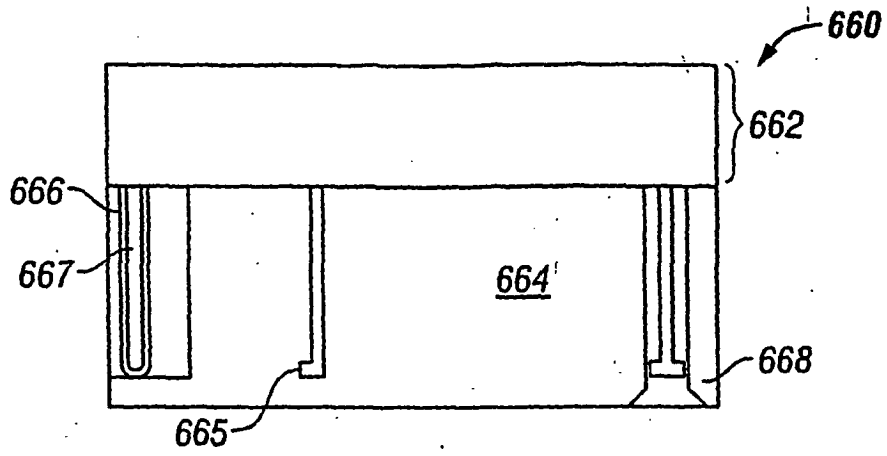


FIG. 63

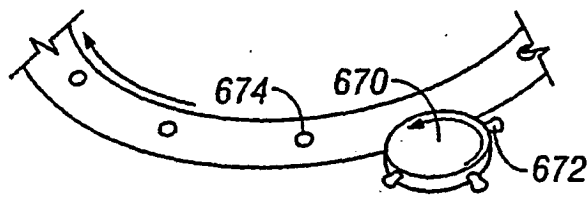


FIG. 64A

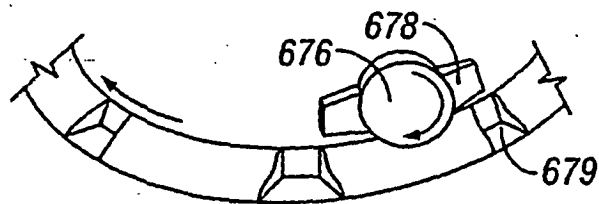


FIG. 64B

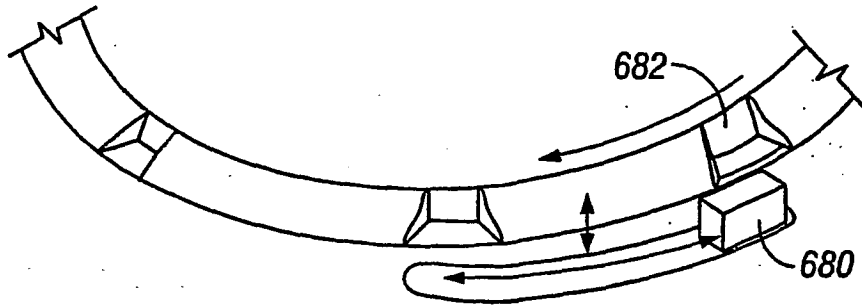


FIG. 64C

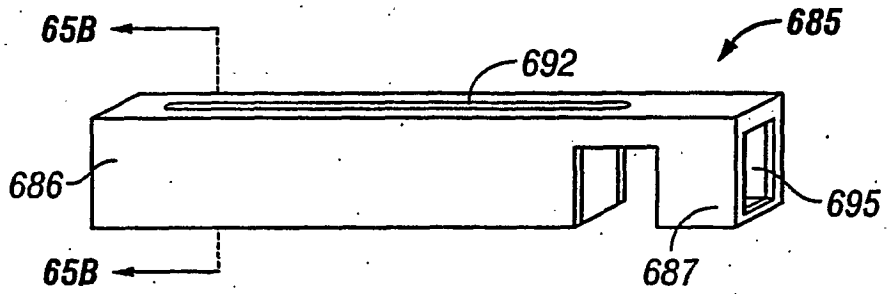


FIG. 65A

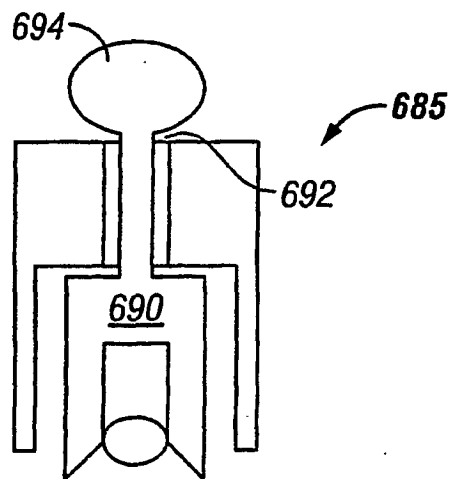


FIG. 65B

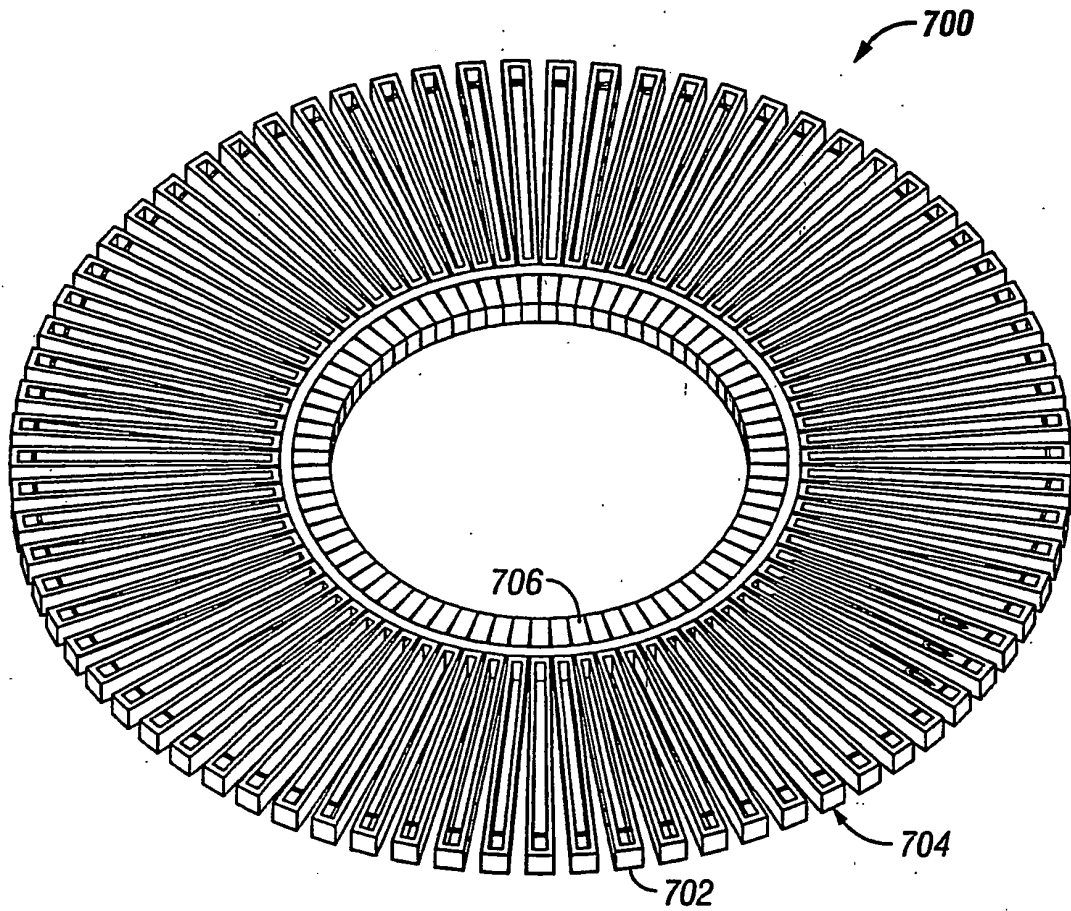


FIG. 66

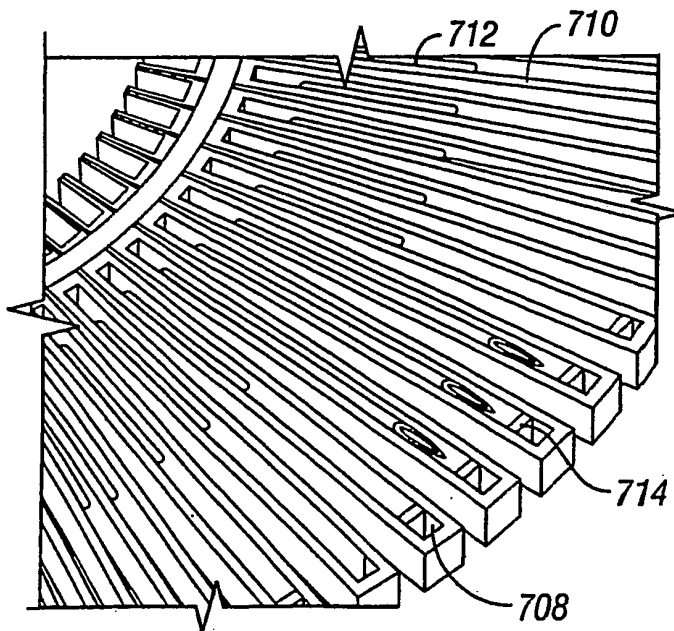


FIG. 67

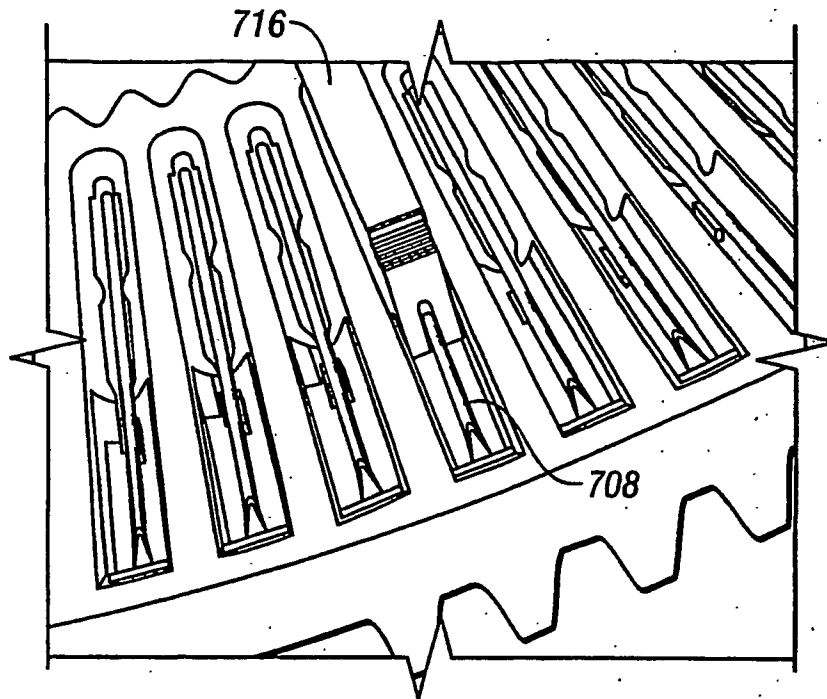


FIG. 68

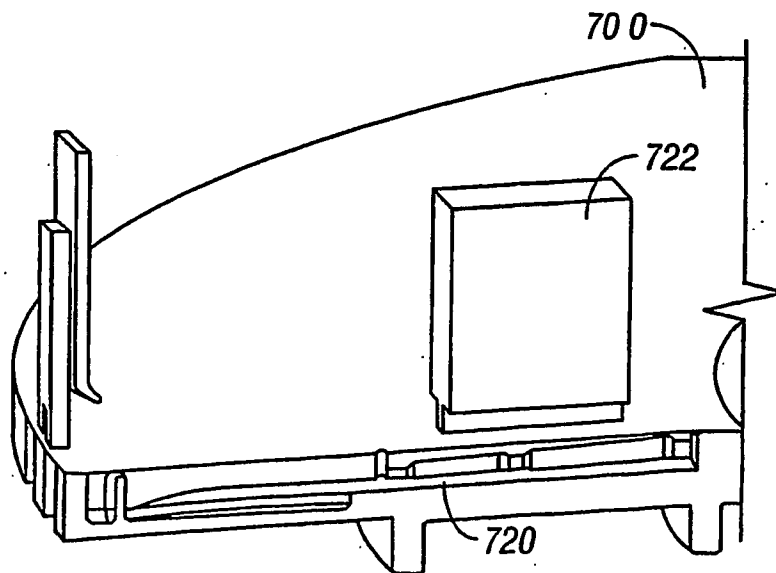


FIG. 69A

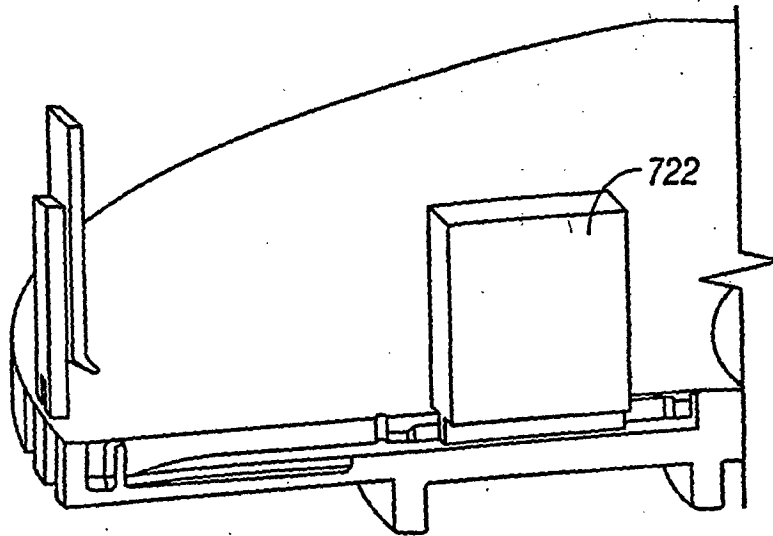


FIG. 69B

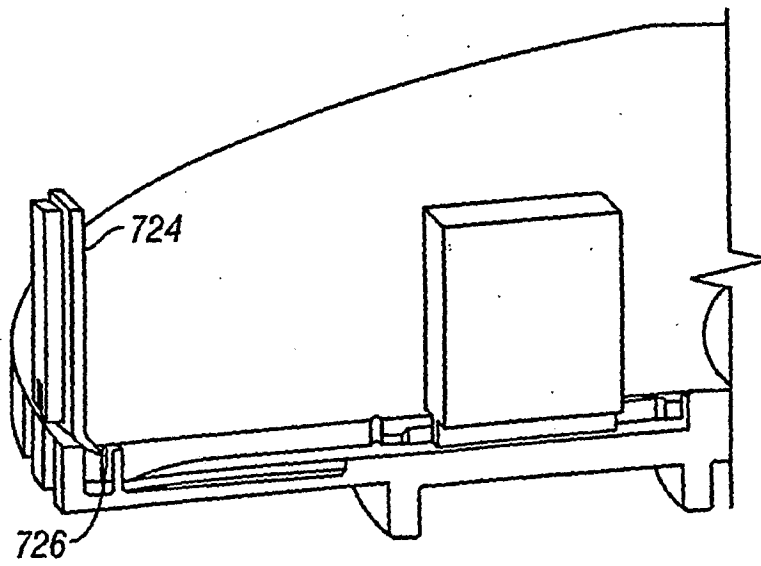


FIG. 69C

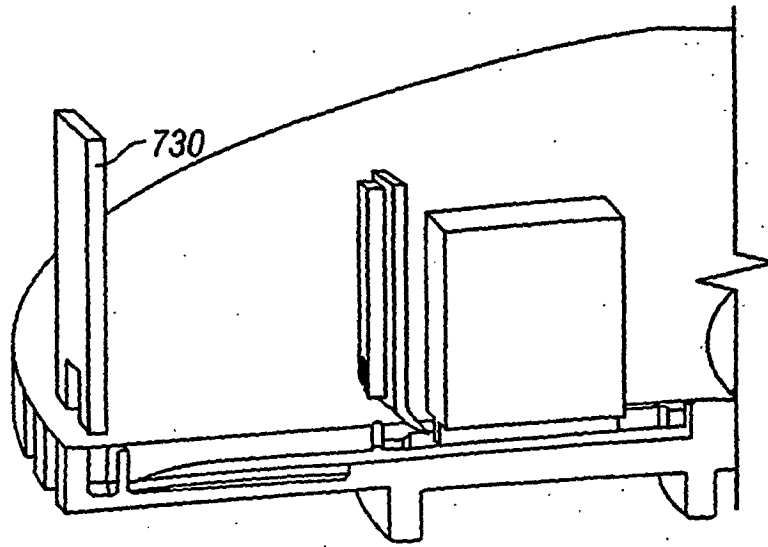


FIG. 69D

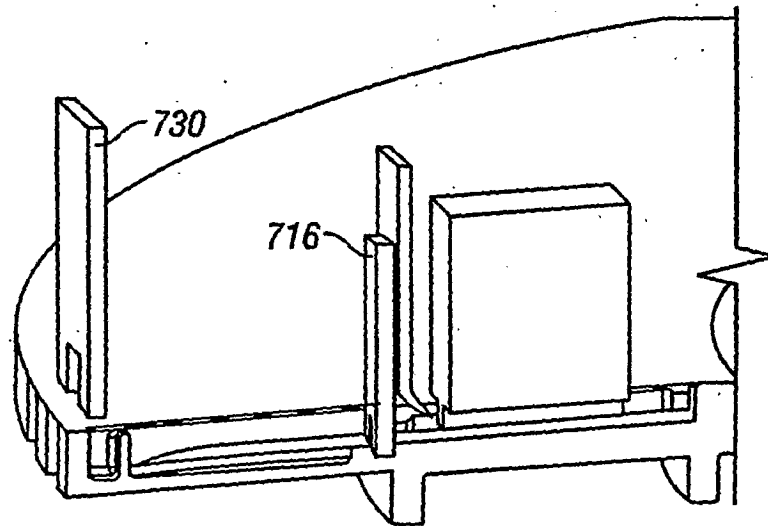


FIG. 69E

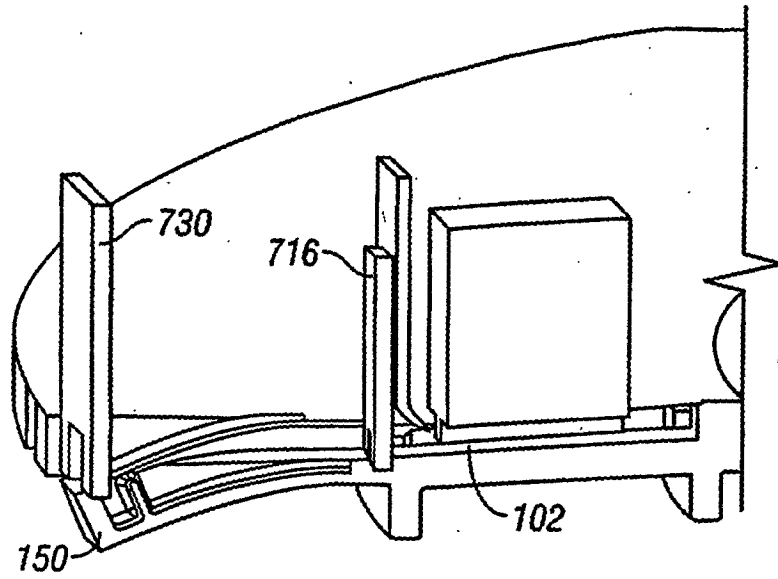


FIG. 69F

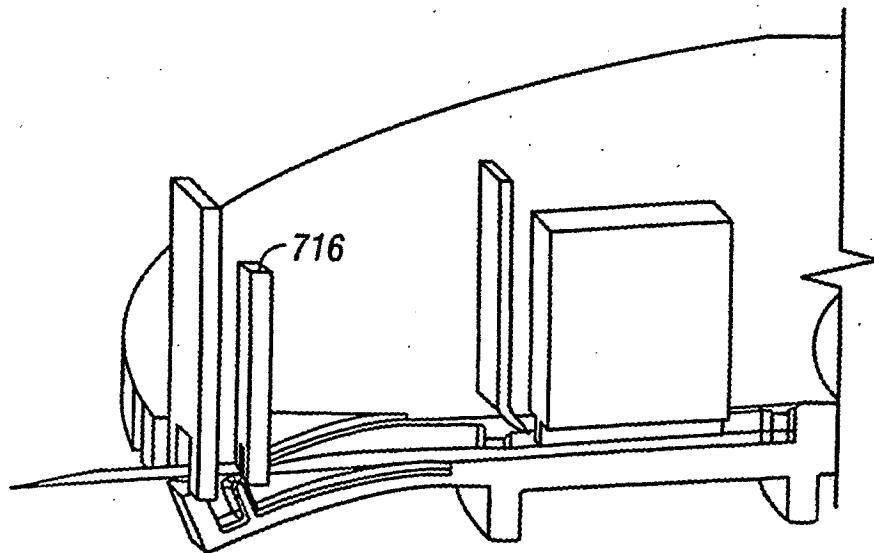


FIG. 69G

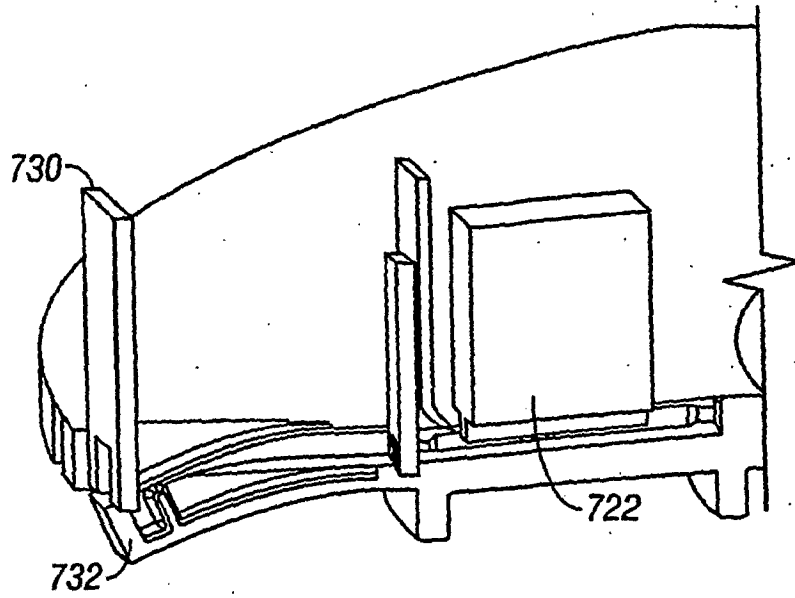


FIG. 69H

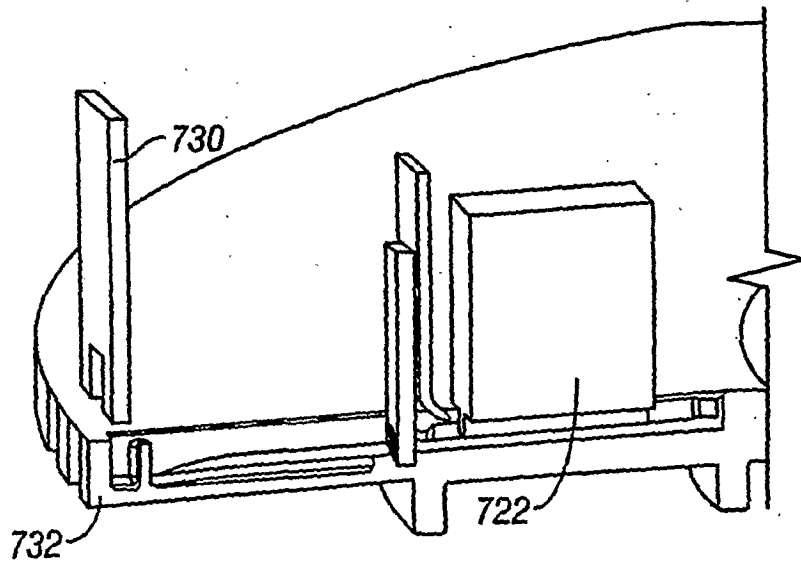


FIG. 69I

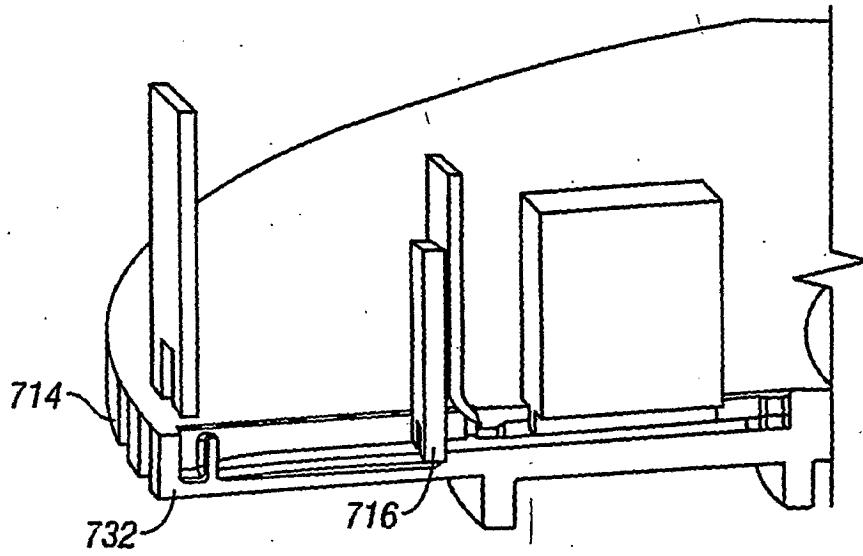


FIG. 69J

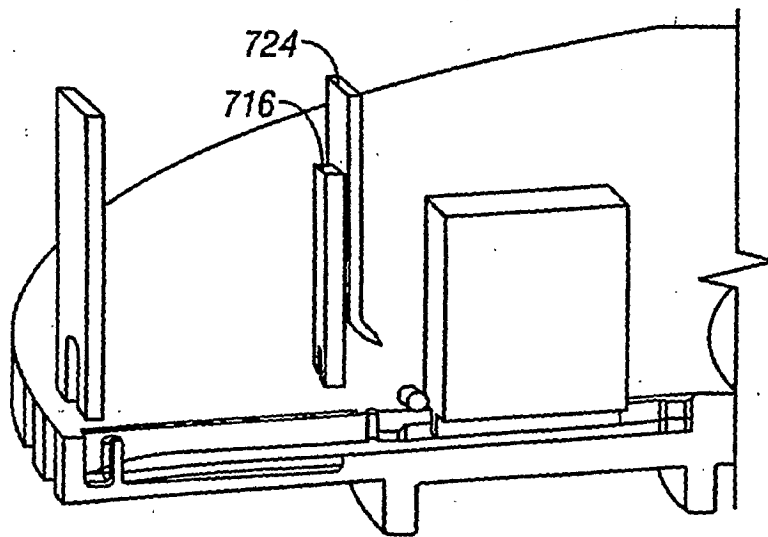


FIG. 69K

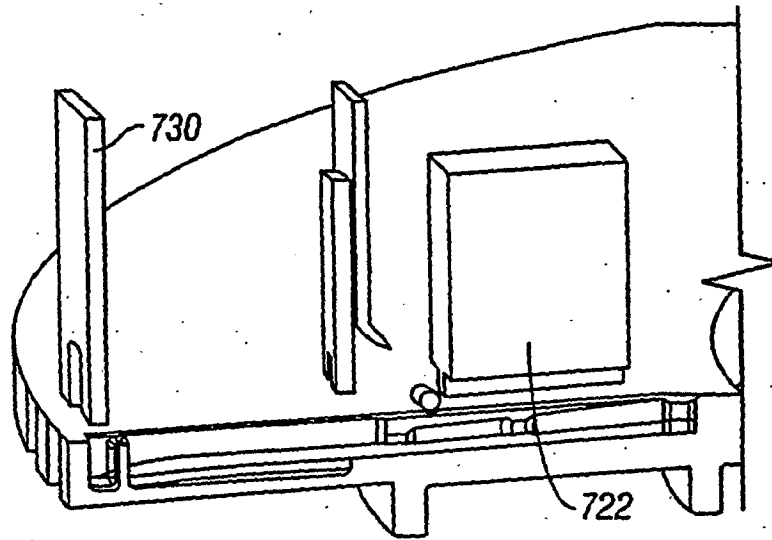


FIG. 69L

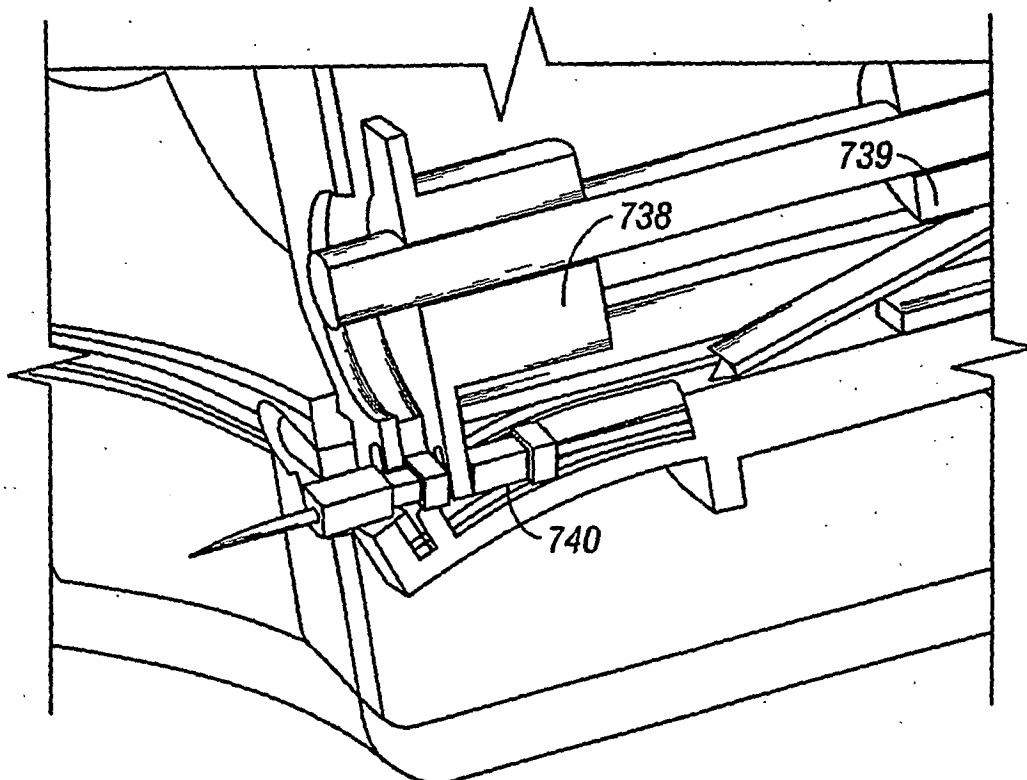


FIG. 70

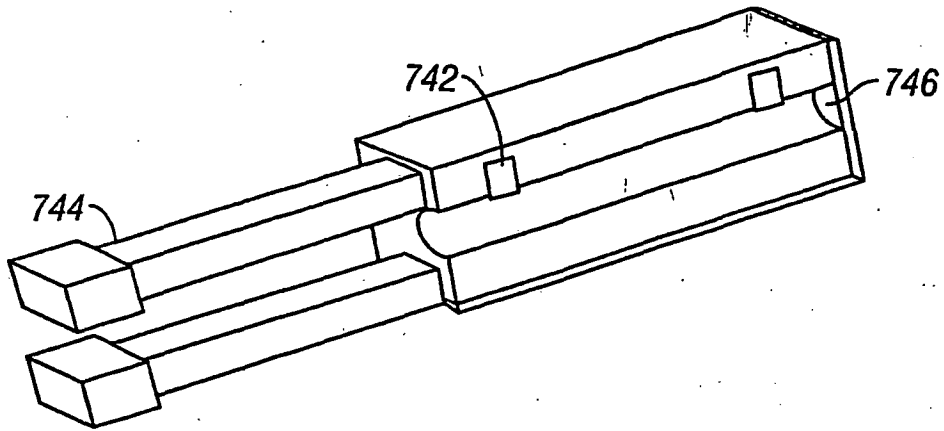


FIG. 71

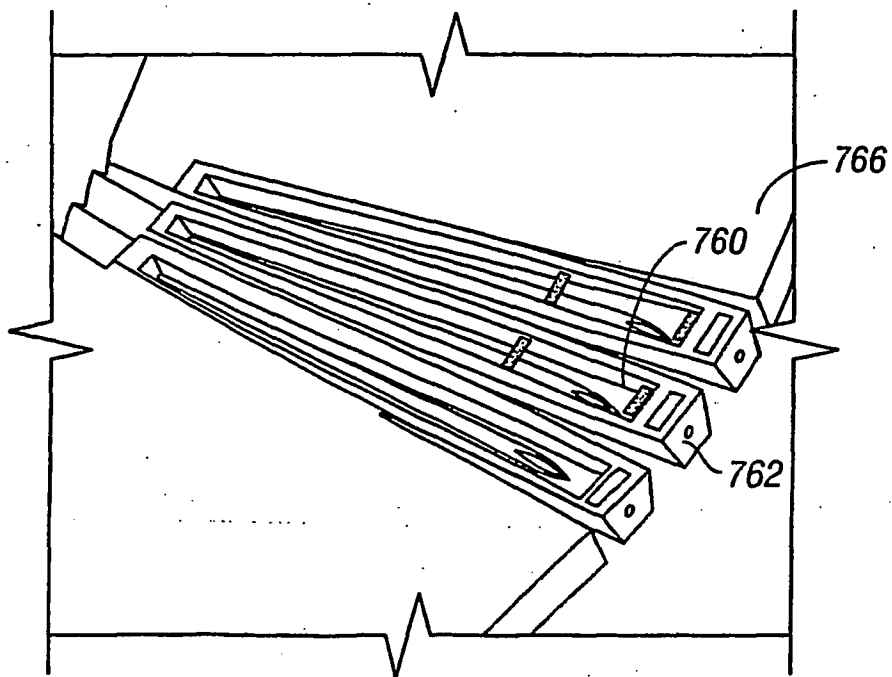


FIG. 72

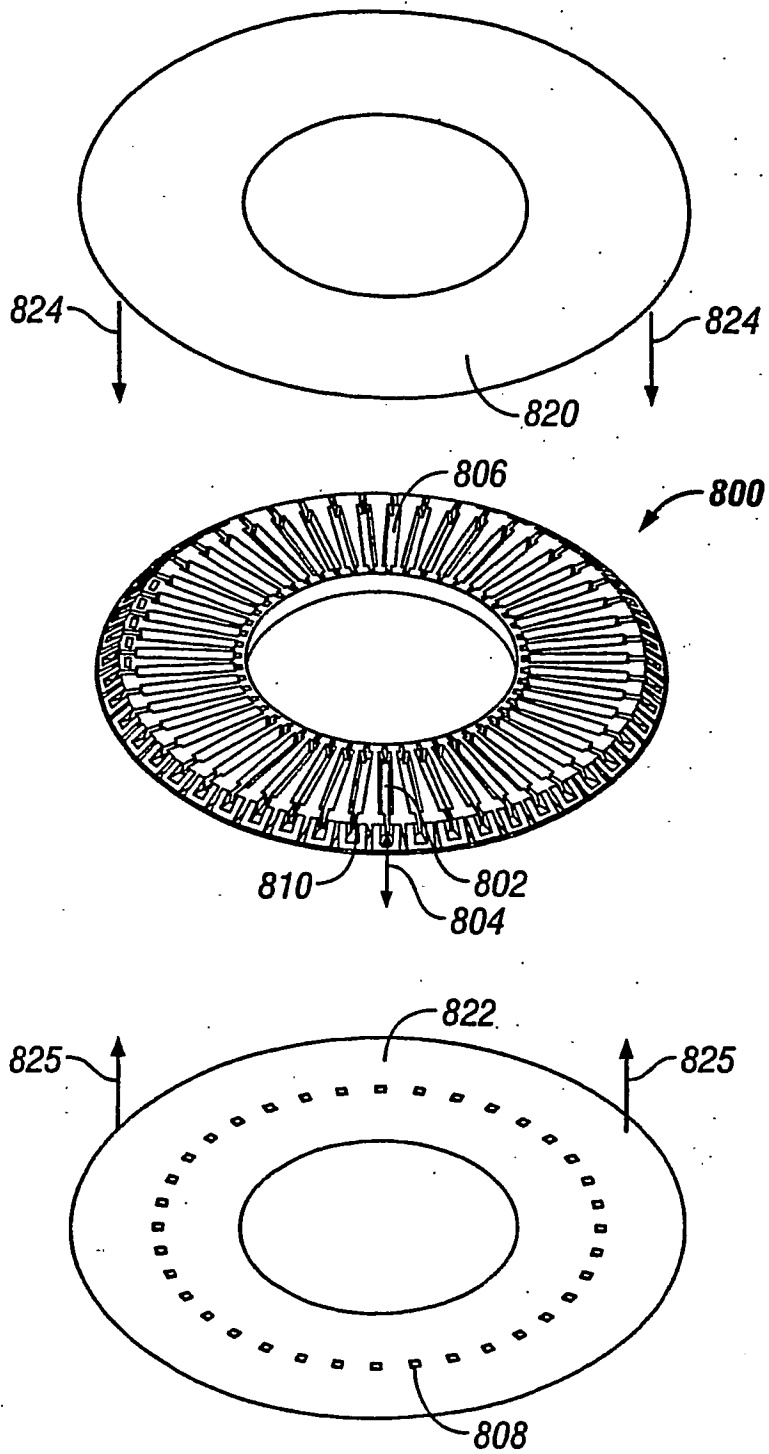


FIG. 73

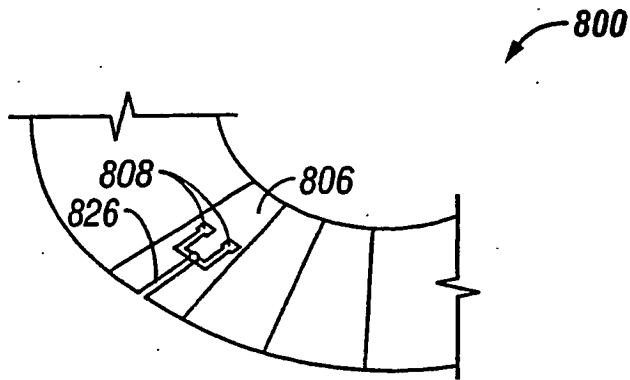


FIG. 74

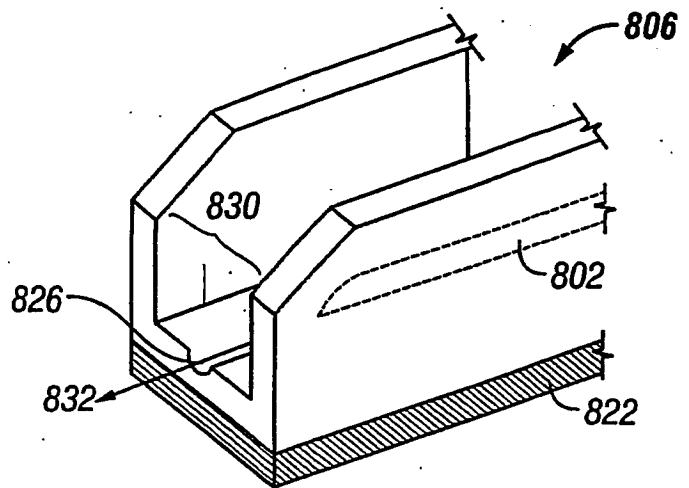


FIG. 75

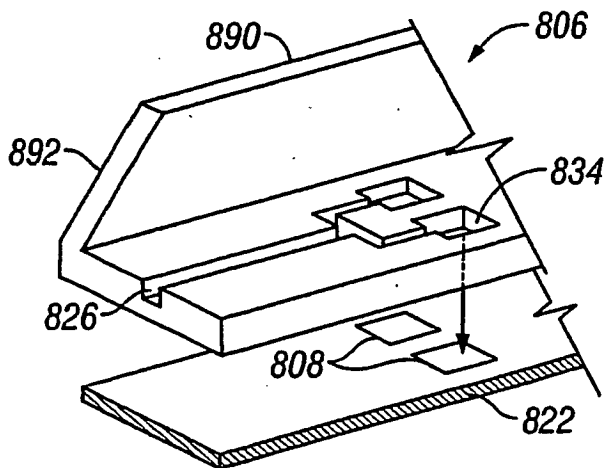


FIG. 76

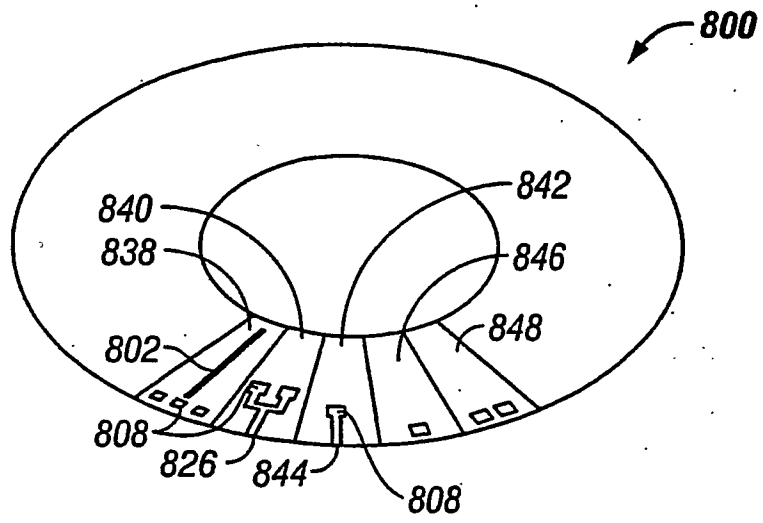


FIG. 77

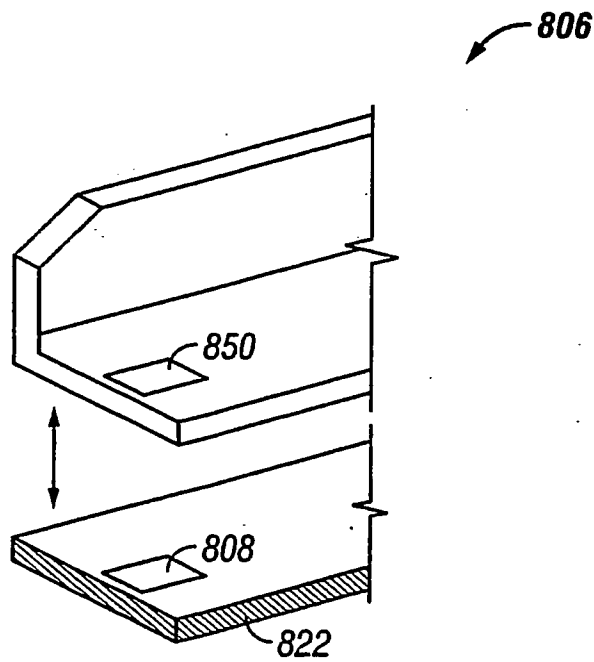


FIG. 78

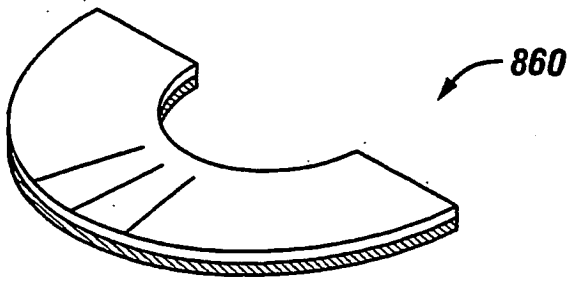


FIG. 79

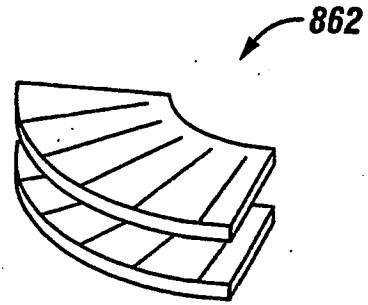


FIG. 80

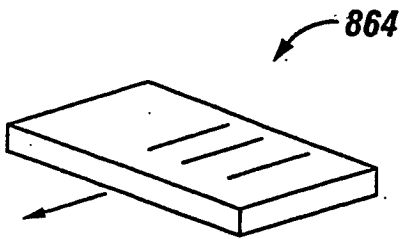


FIG. 81

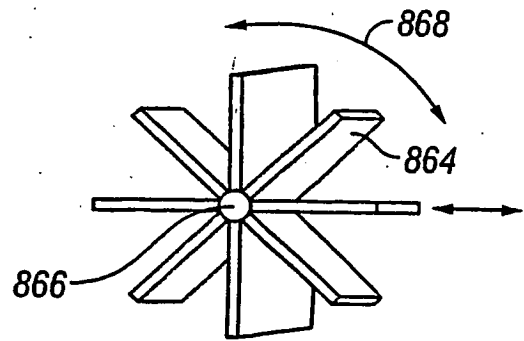


FIG. 82

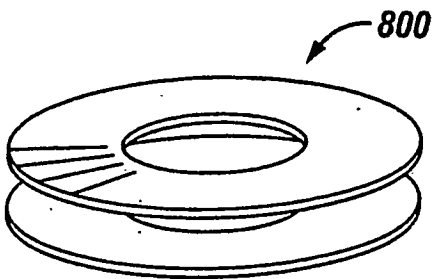


FIG. 83

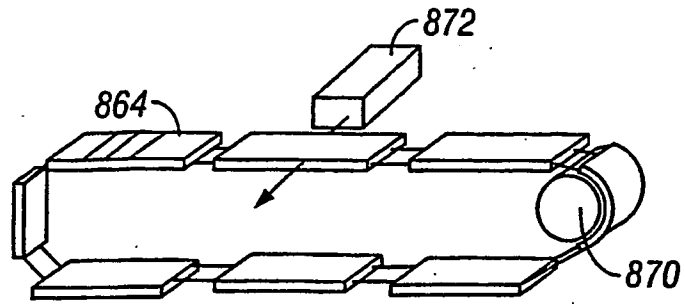


FIG. 84

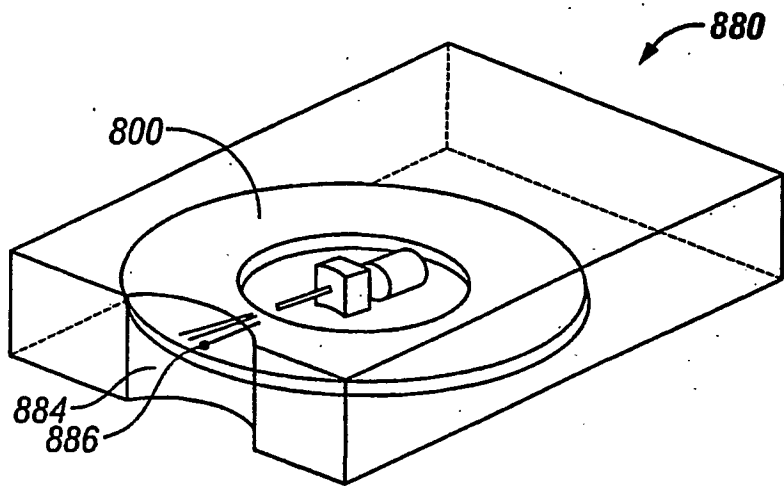


FIG. 85

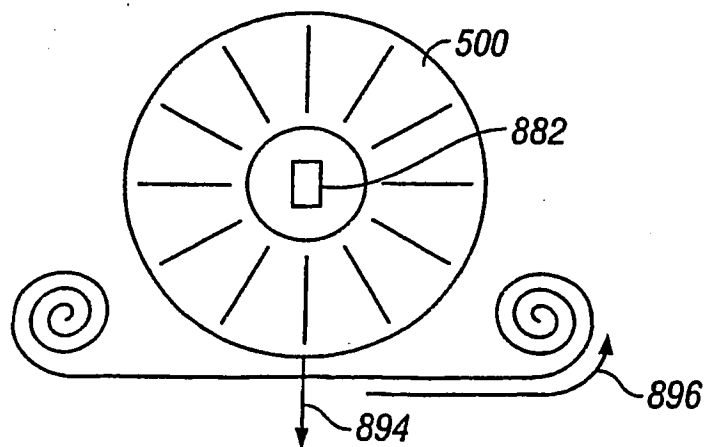


FIG. 86

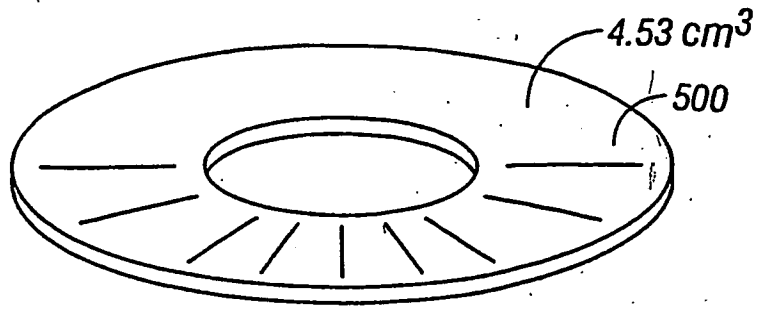


FIG. 87A

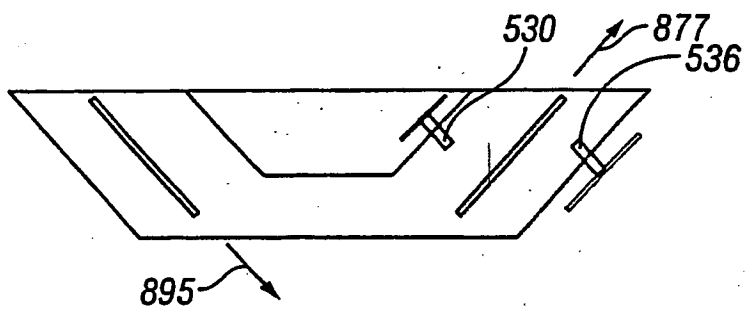


FIG. 87B

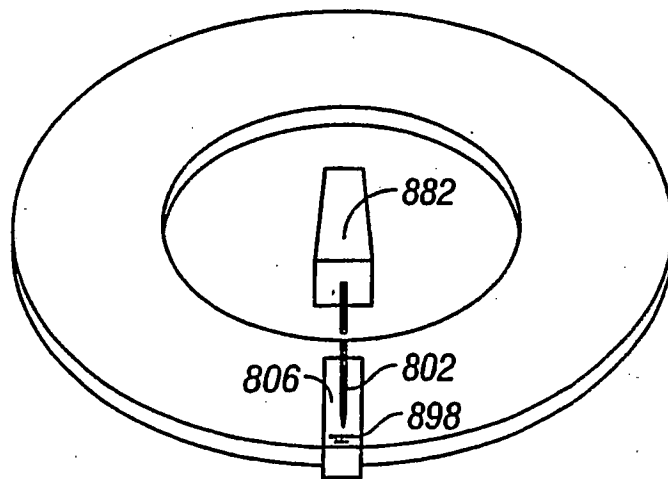


FIG. 88

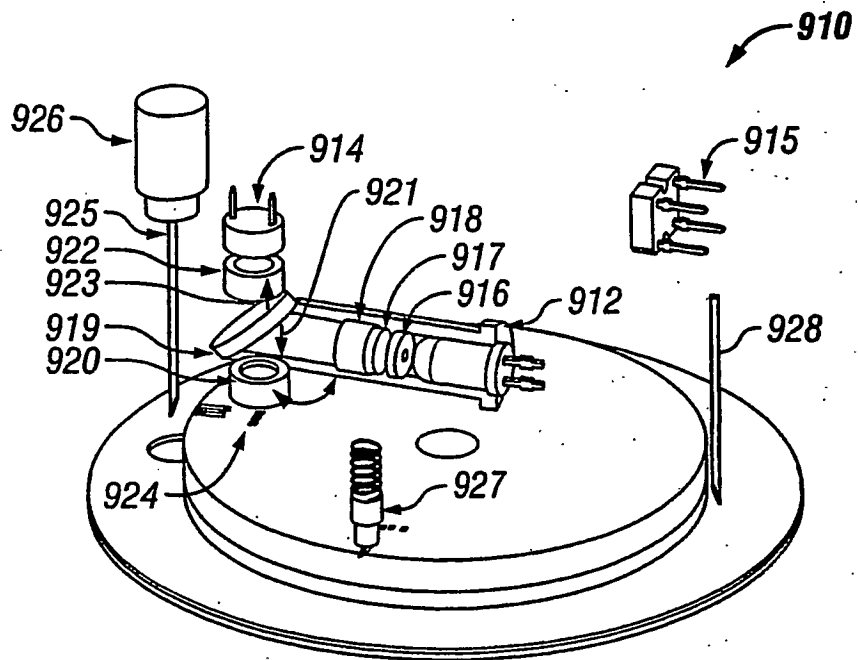


FIG. 89

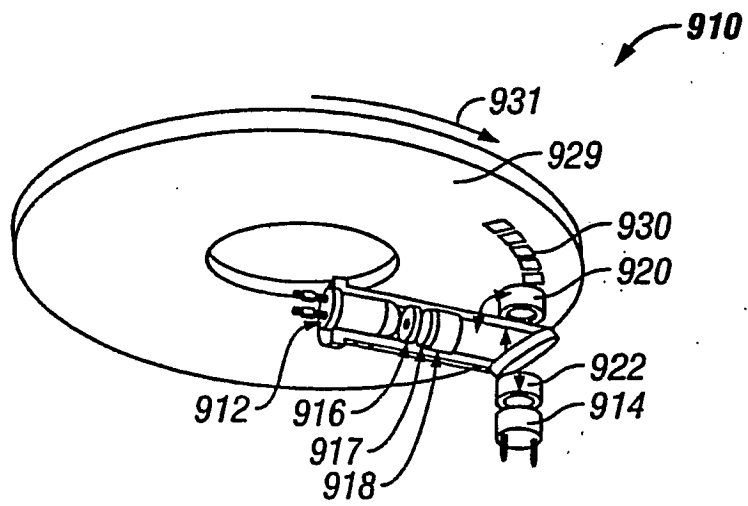


FIG. 90

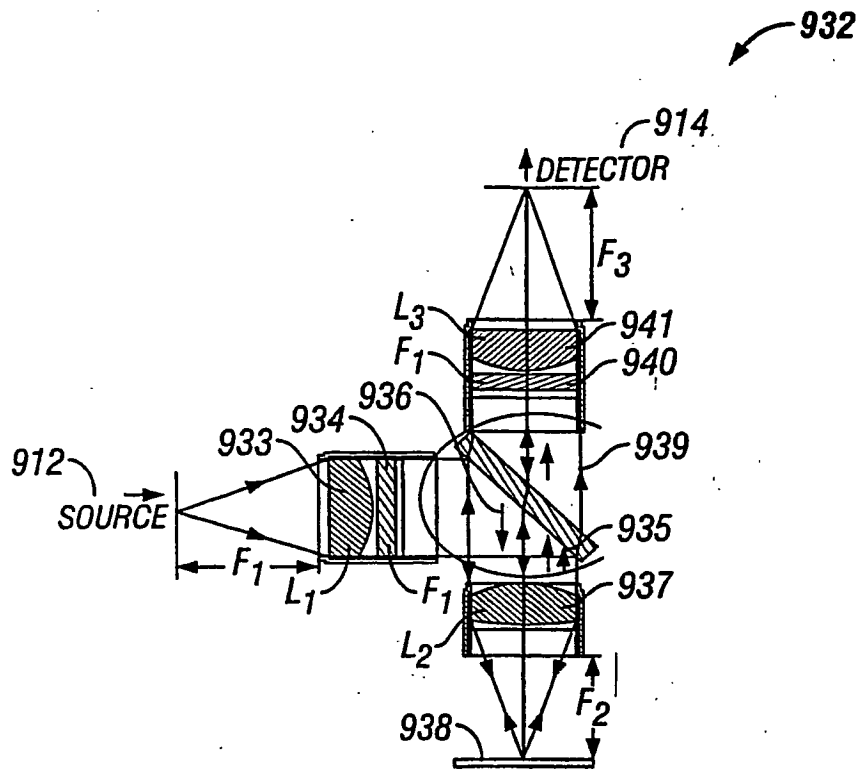


FIG. 91

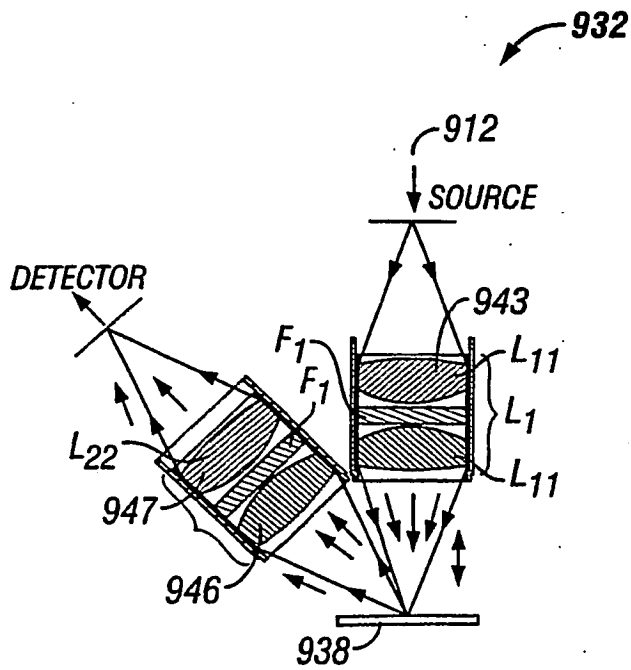


FIG. 92

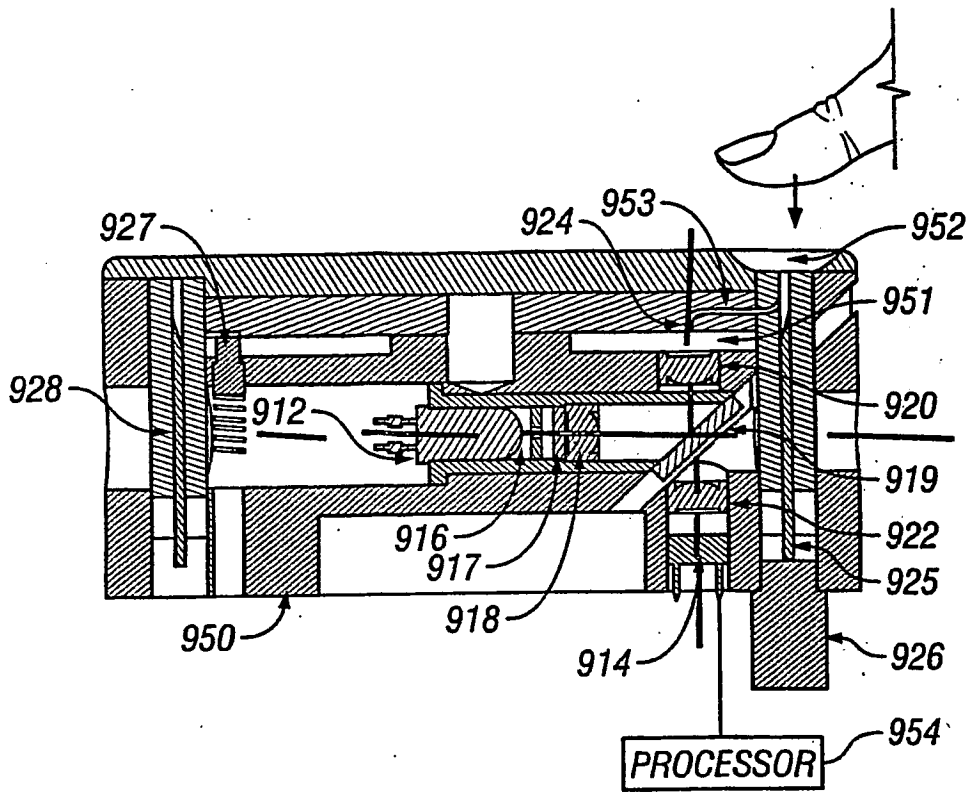


FIG. 93

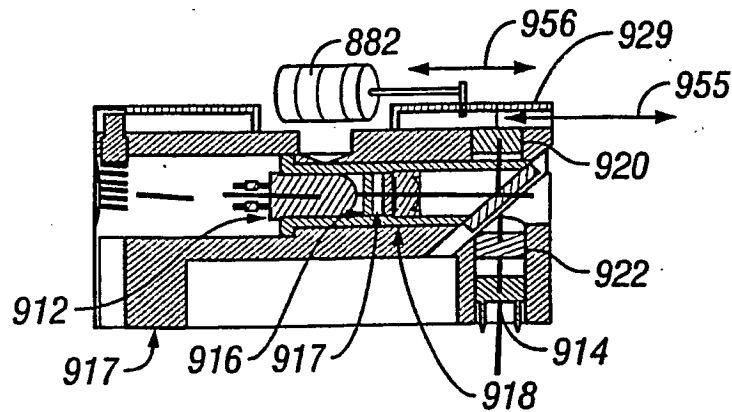


FIG. 94

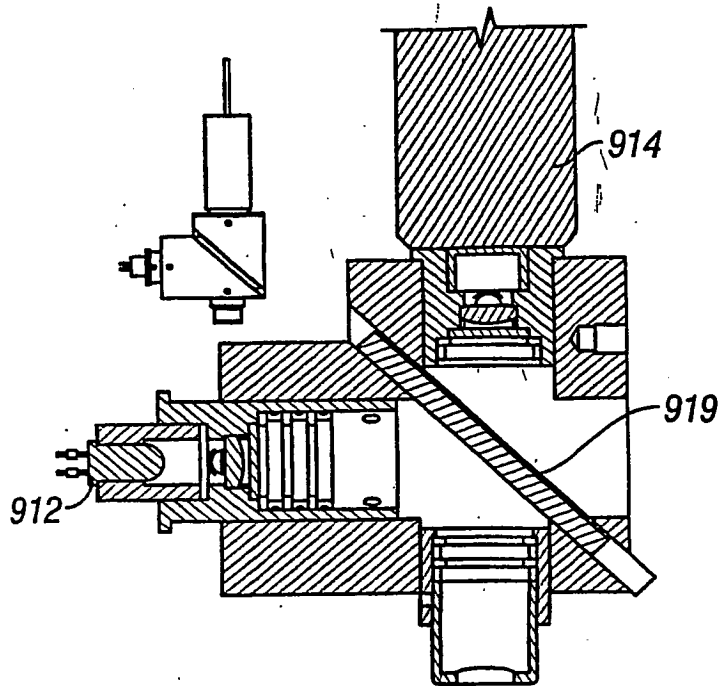


FIG. 95

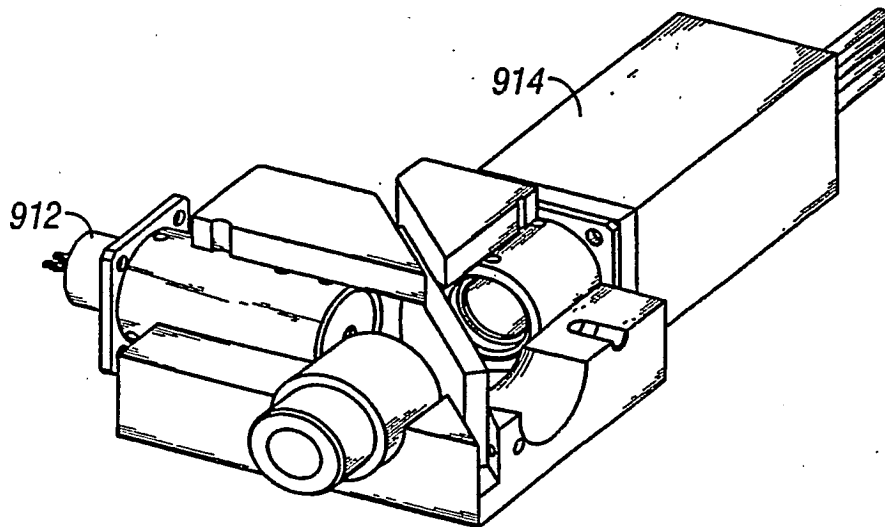


FIG. 96

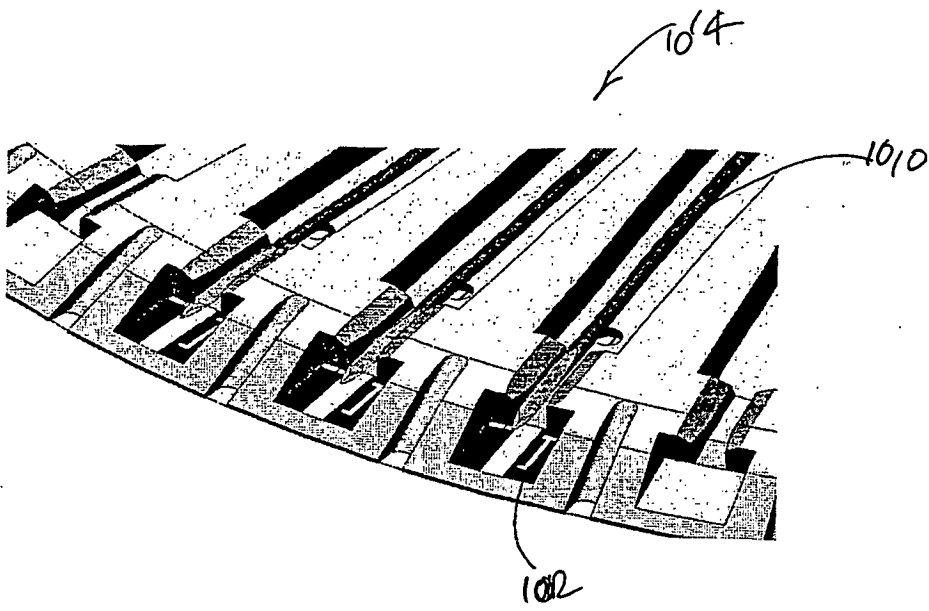


FIG-97

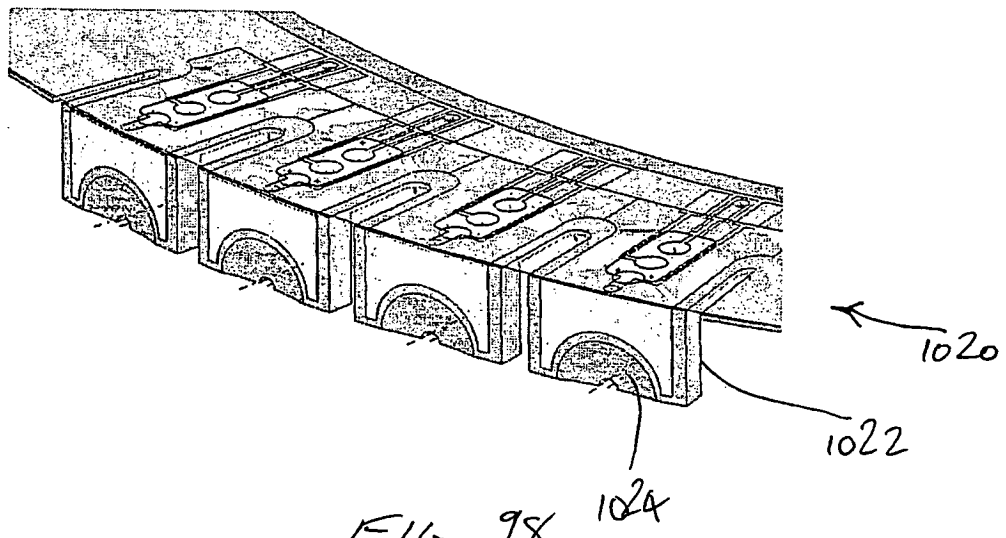
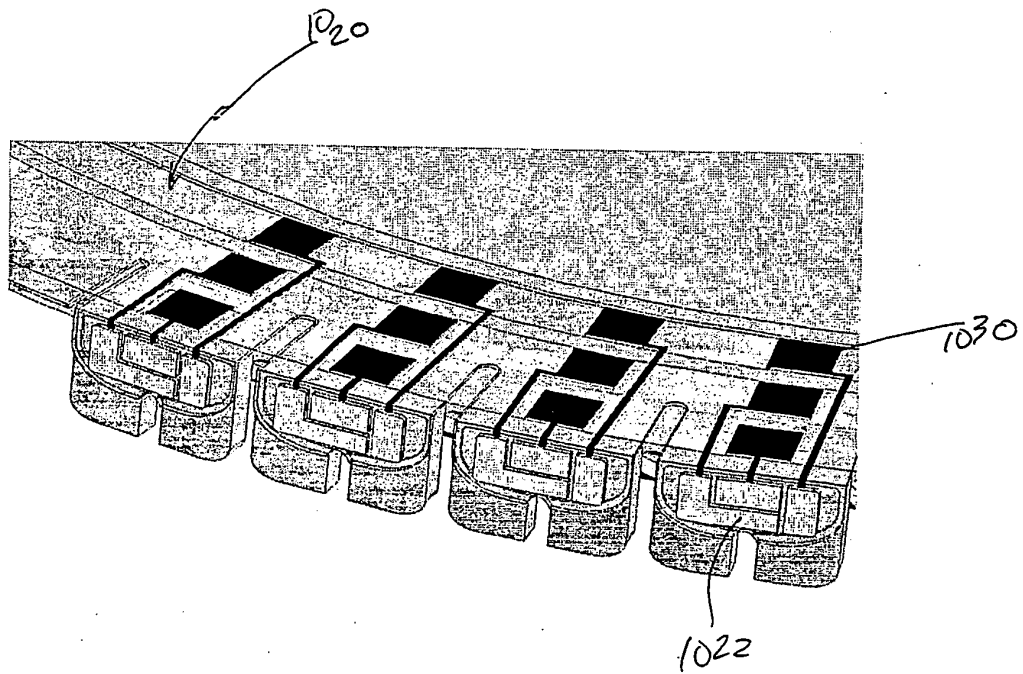
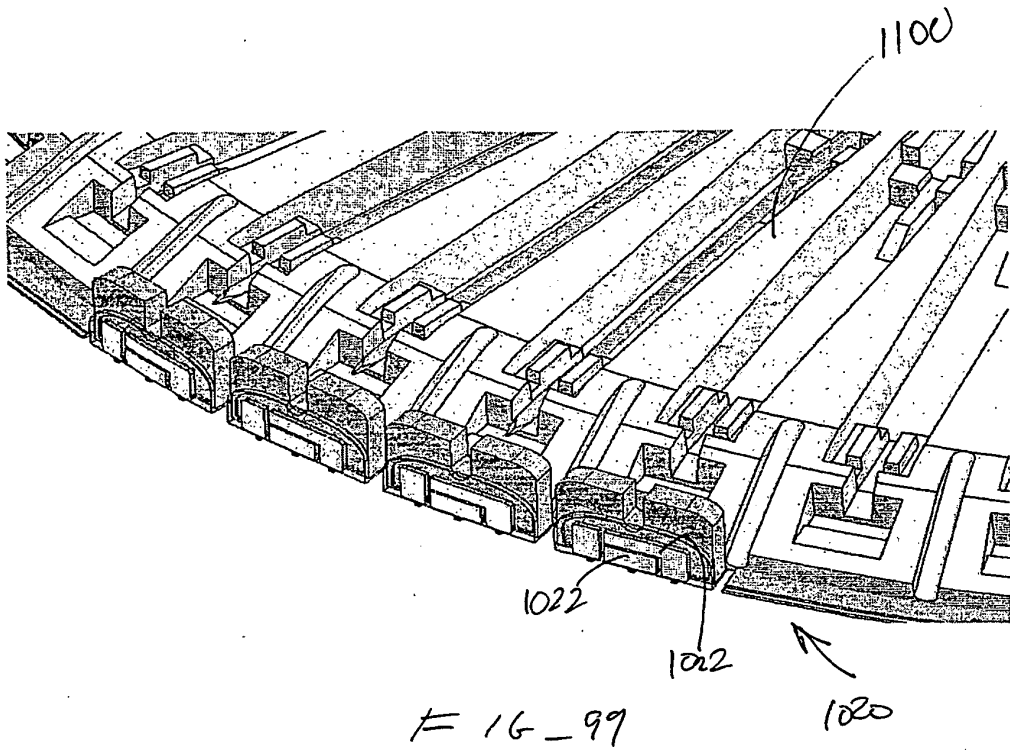
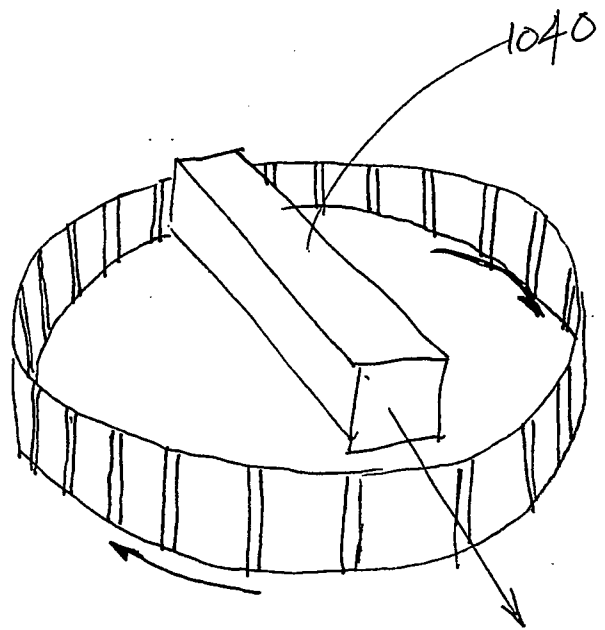
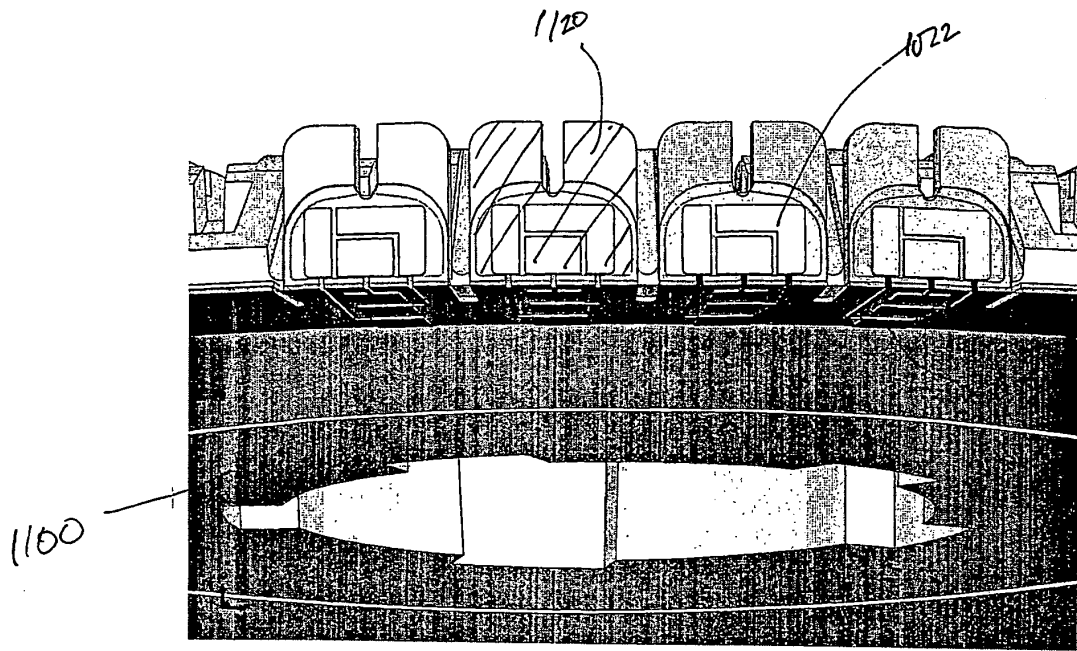


FIG-98

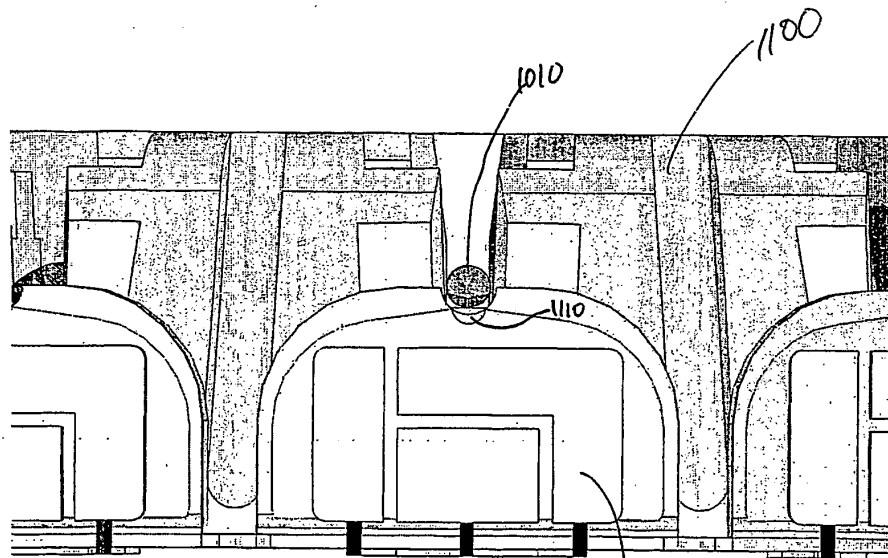




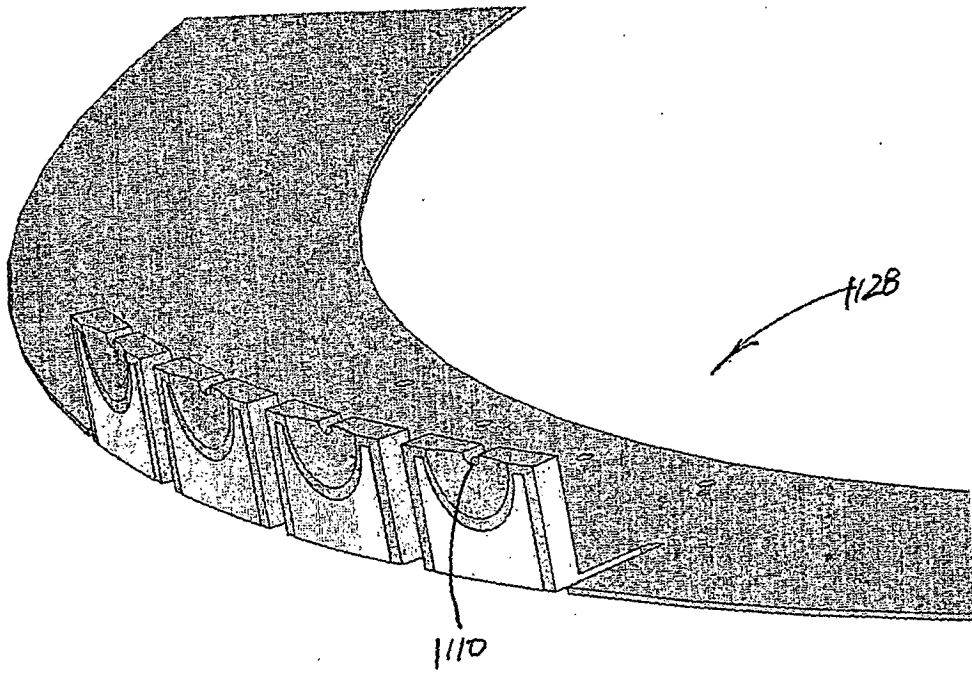
FIG_101



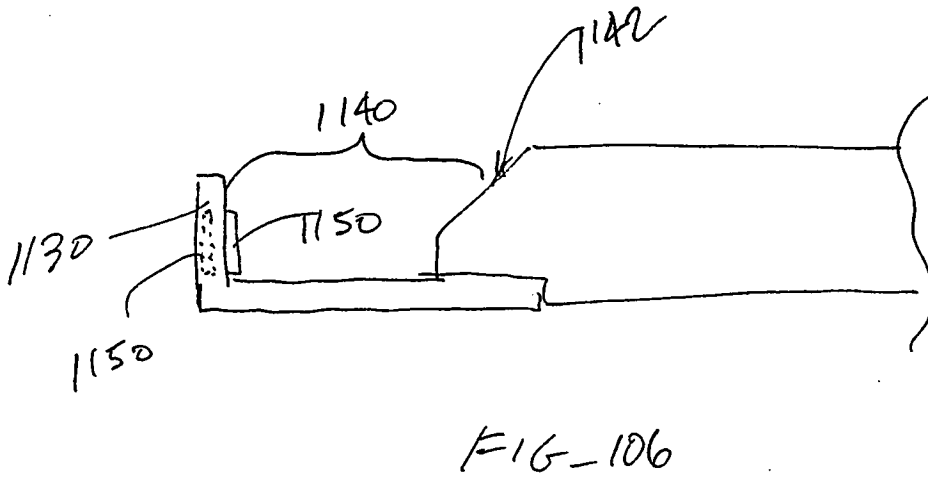
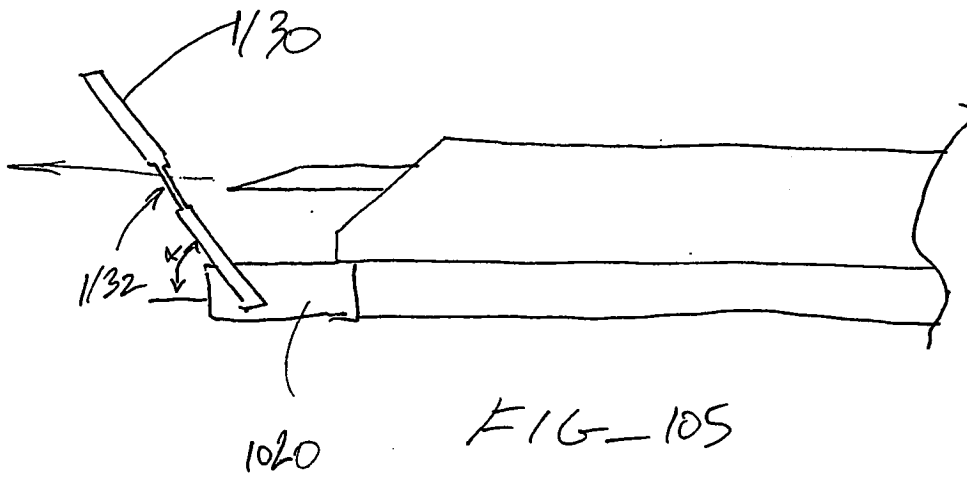
FIG_102

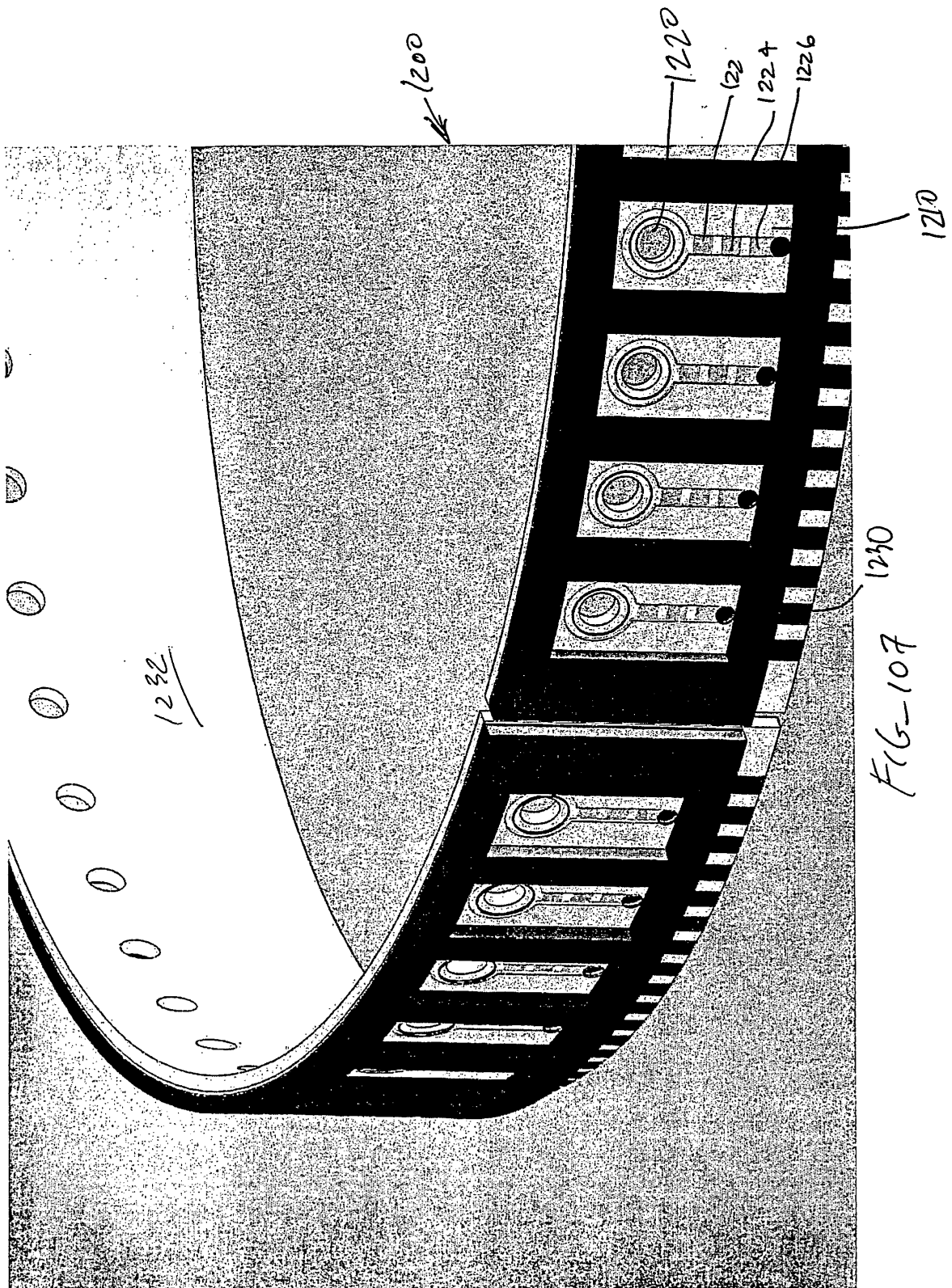


FIG_103



FIG_104





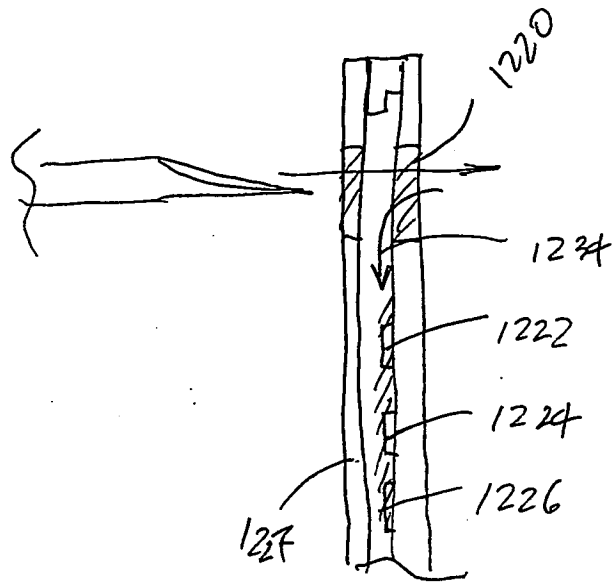


FIG - 108

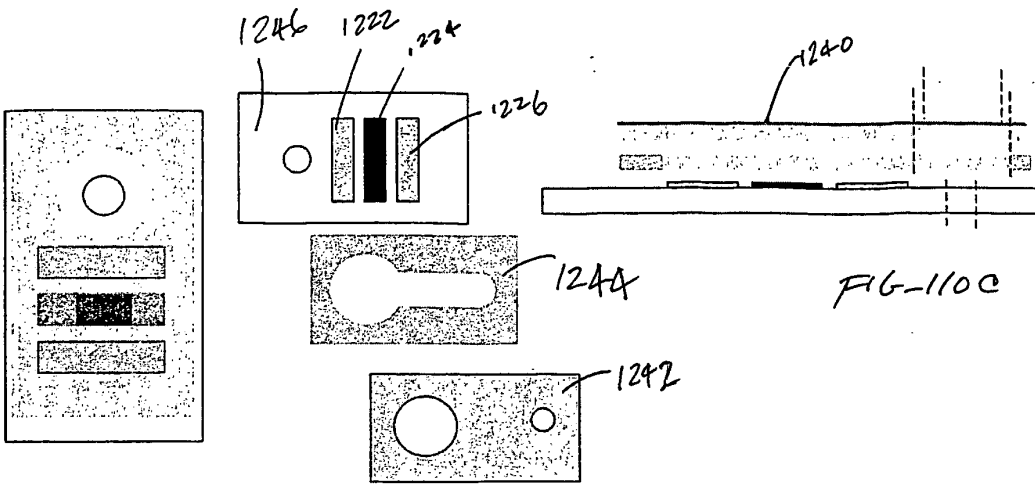


FIG-110A

FIG-110B

FIG-110C

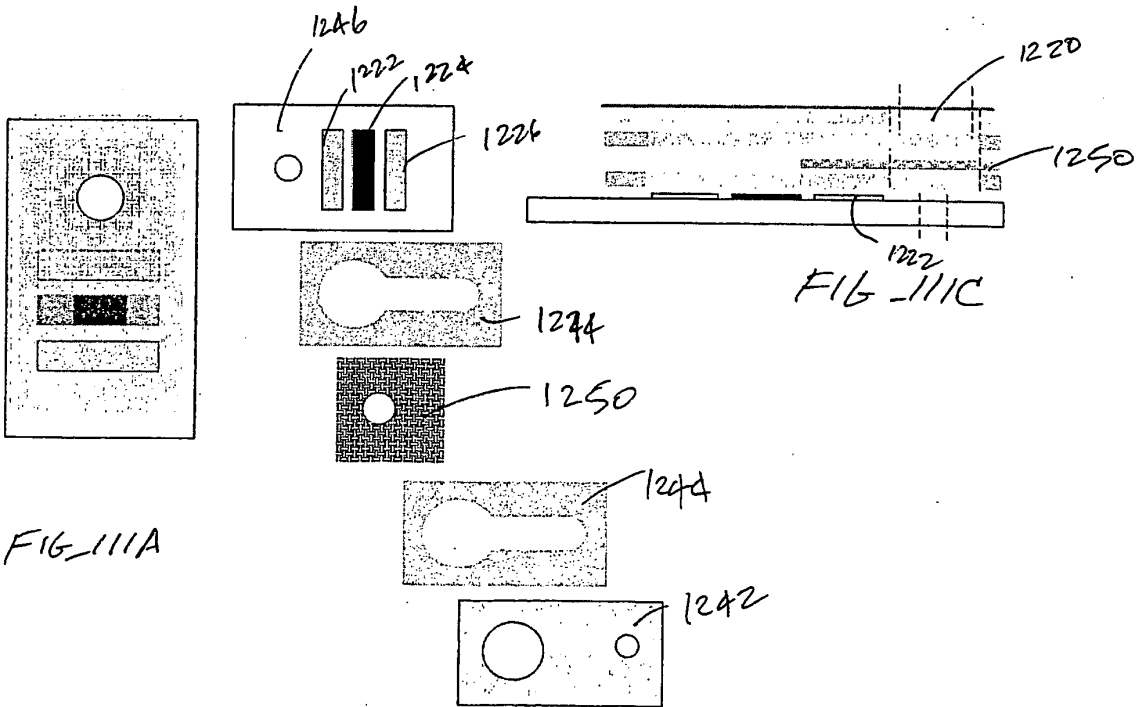
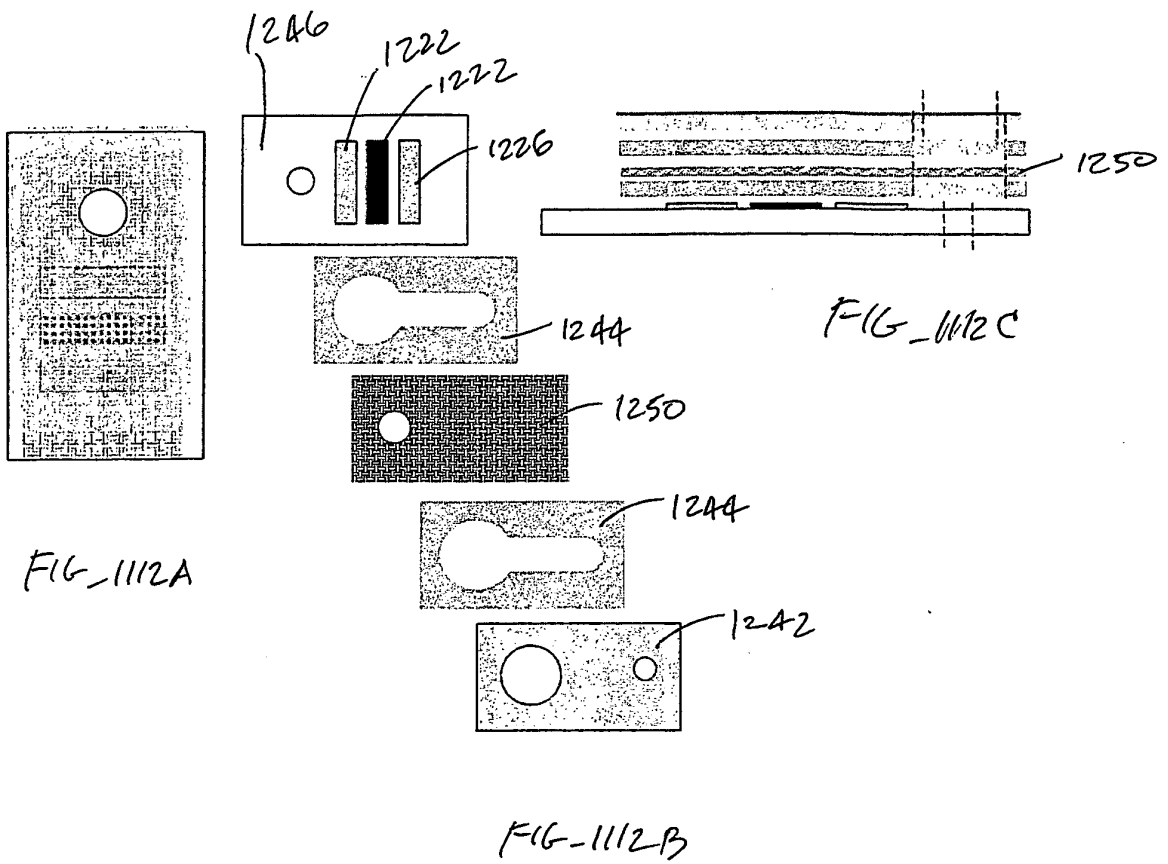


FIG-111A

FIG-111B

FIG-111C



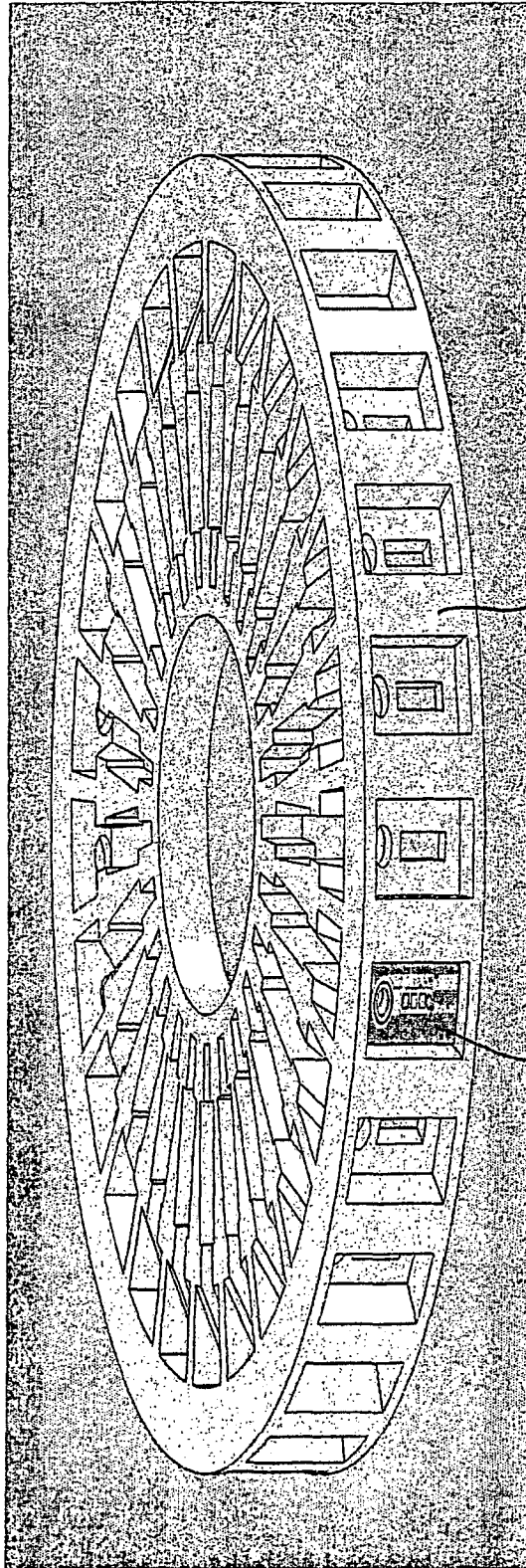


FIG-113

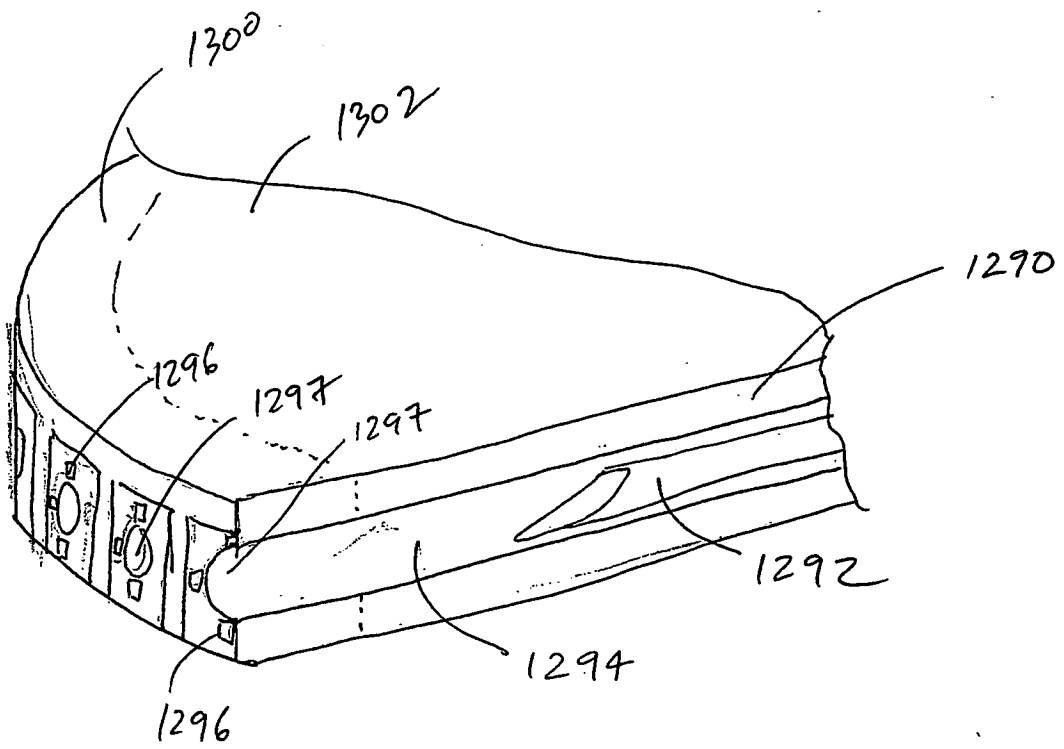


FIG-114

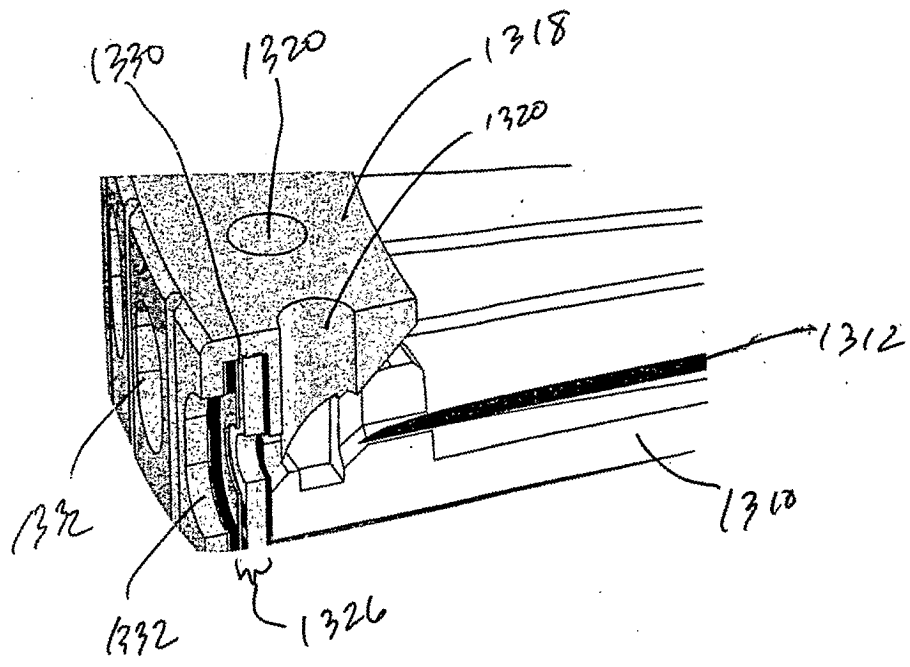


FIG-115

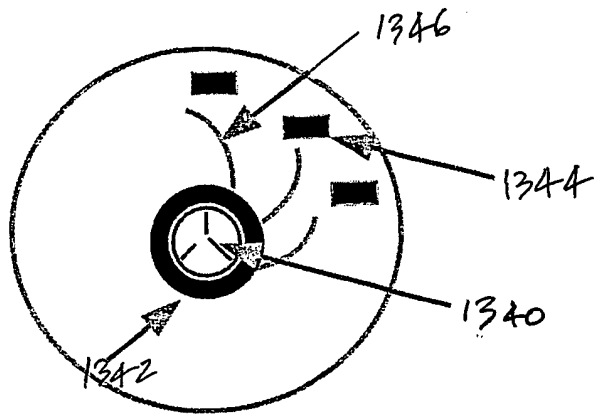


FIG-116

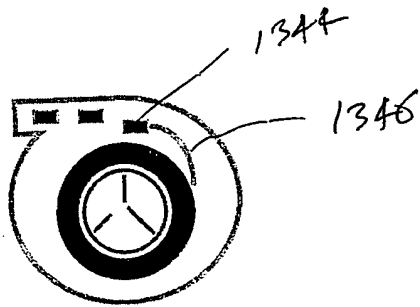


FIG-117

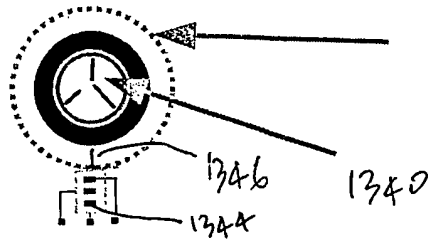


FIG-118

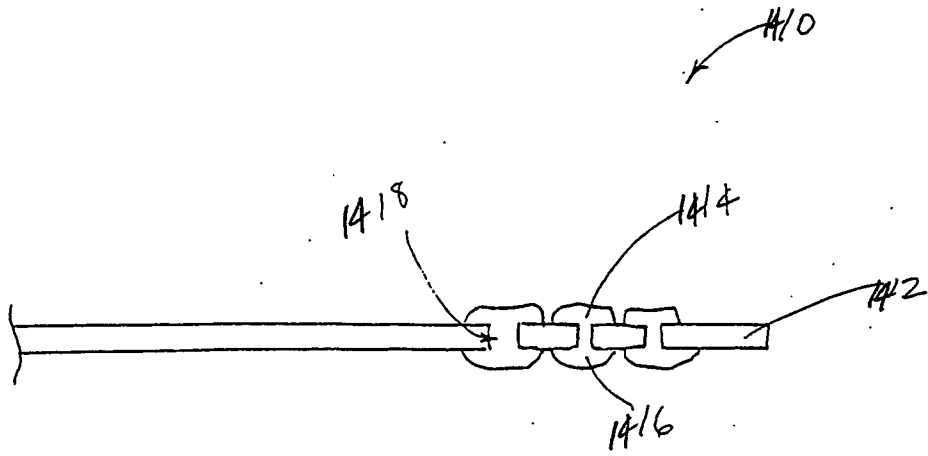


FIG - 119

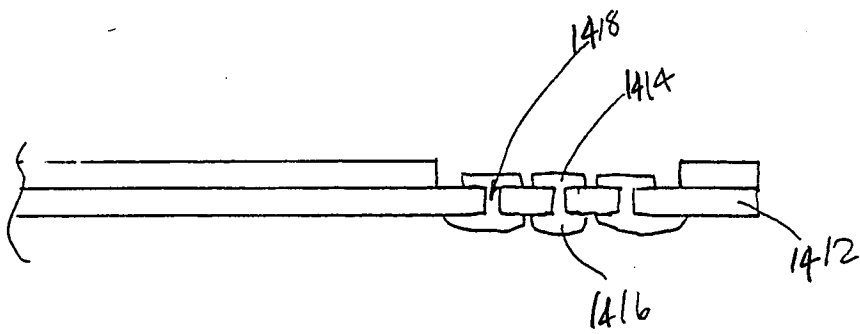


FIG - 120

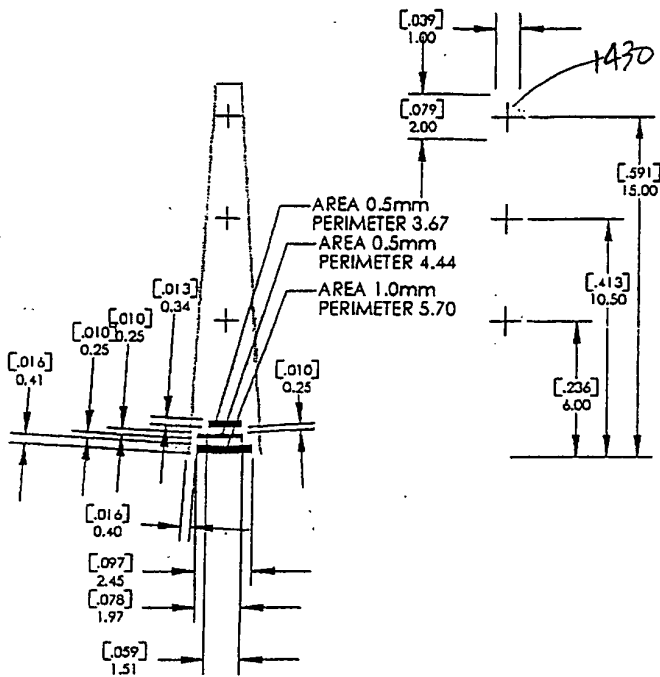


FIG-122

FIG-121

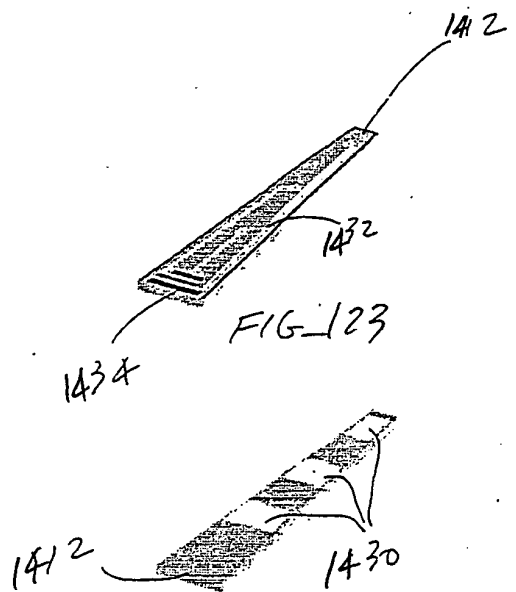


FIG-123



FIG-12A

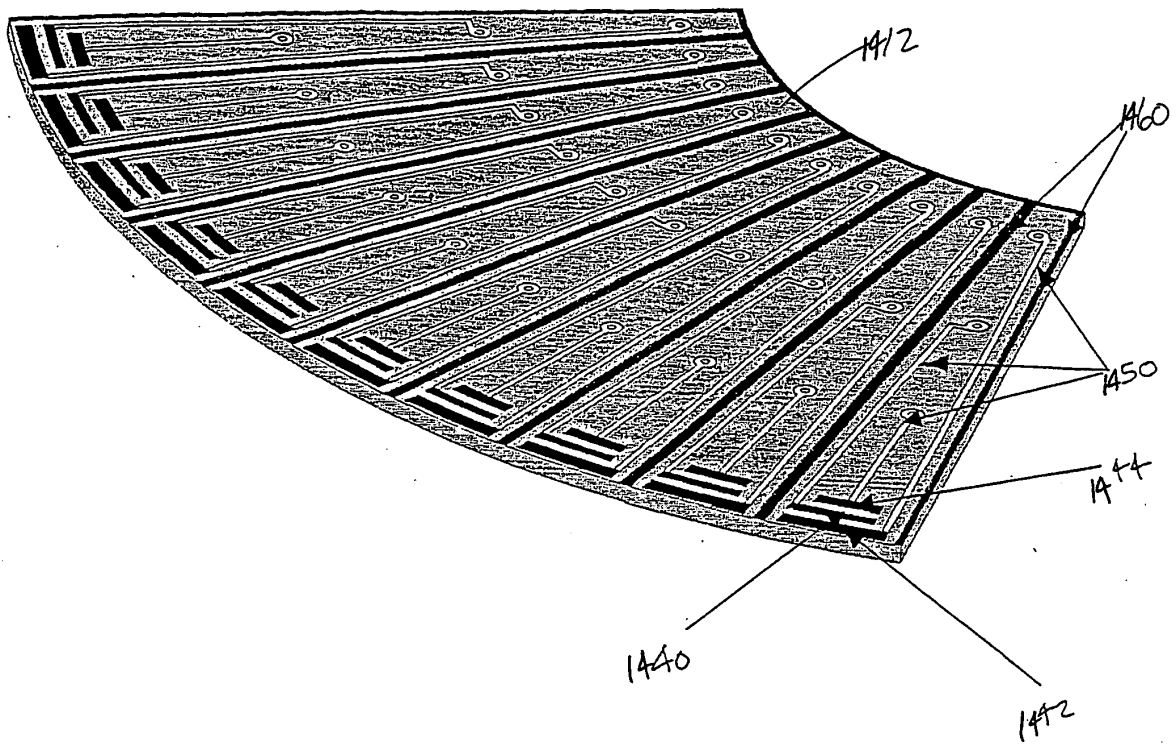


FIG-129

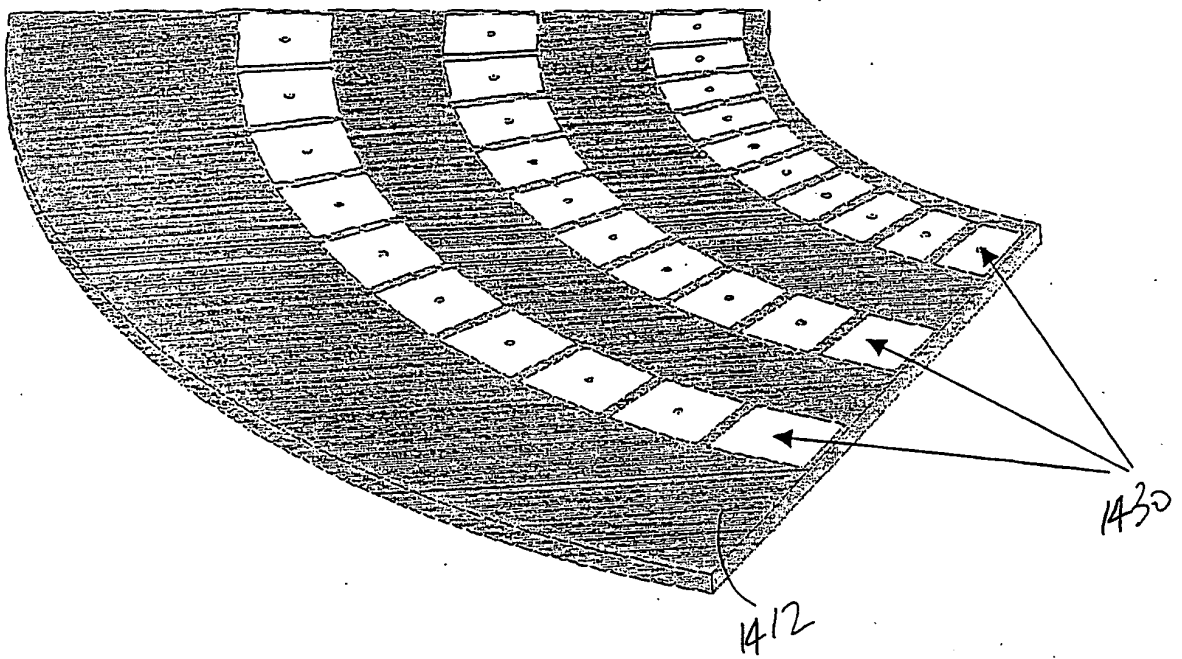


FIG-126

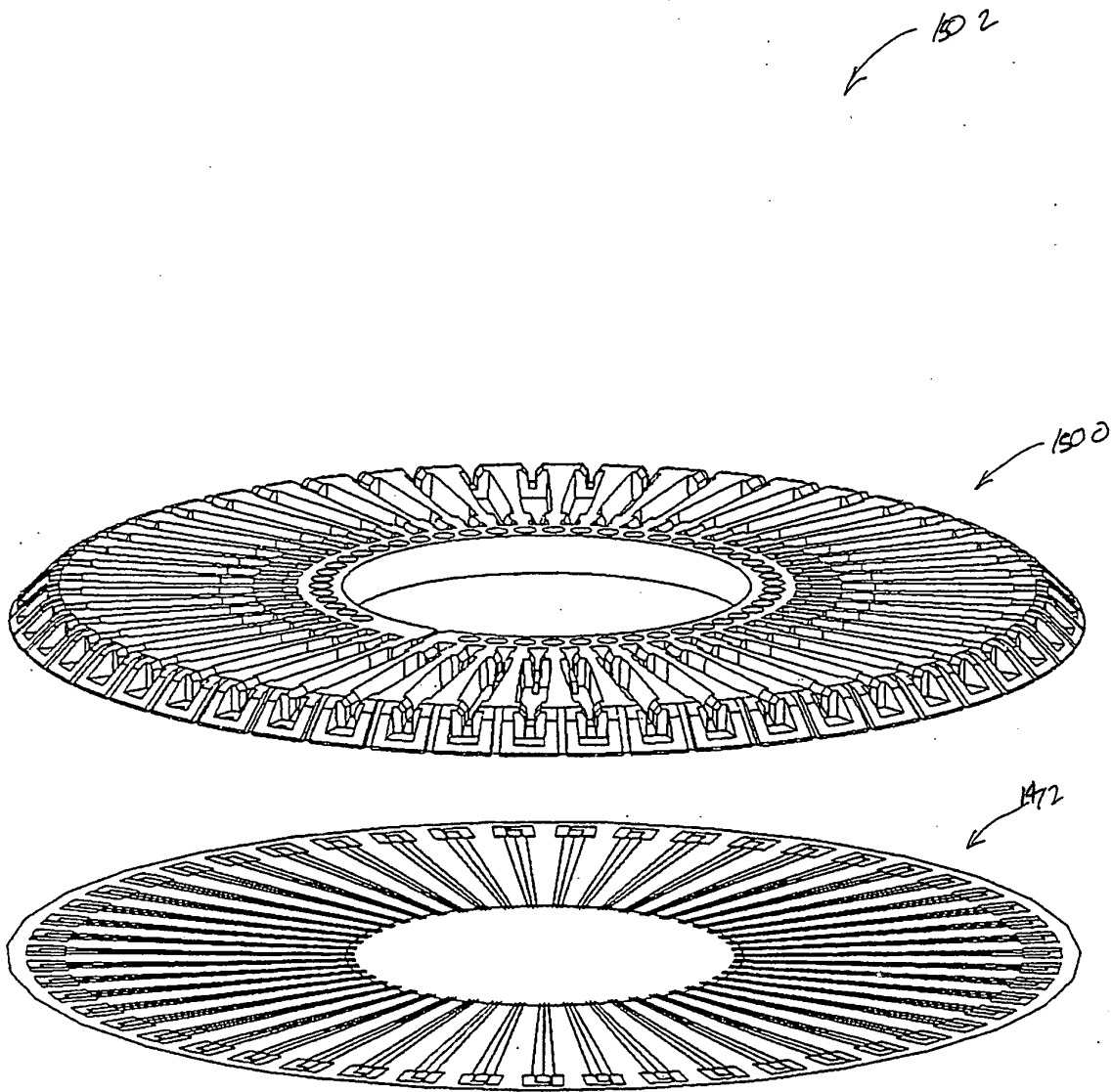


FIG- 127

REFERENCES CITED IN THE DESCRIPTION

This list of references cited by the applicant is for the reader's convenience only. It does not form part of the European patent document. Even though great care has been taken in compiling the references, errors or omissions cannot be excluded and the EPO disclaims all liability in this regard.

Patent documents cited in the description

- US 20030083685 A1 [0007]
- US 6036924 A [0008]
- WO 0200101 A2 [0009]
- DE 10057832 C1 [0010]
- DE 10208575 [0010]
- US 5997817 A, Chrismore [0060]
- US 5059394 A, Phillips [0060]
- US 5001054 A, Wagner [0060]
- US 4392933 A, Nakamura [0060]
- US 127395 A [0068]
- US 12739502 A [0141] [0215] [0218]
- US 42919603 A [0179] [0211]
- US 32362202 A [0218]
- US 32362302 A [0218]
- US 32362402 A [0218]
- US 33514202 A [0218]
- US 10335215 A [0218]
- US 10335258 A [0218]
- US 10335099 A [0218]
- US 10335219 A [0218]
- US 10335052 A [0218]
- US 10335073 A [0218]
- US 10335220 A [0218]
- US 10335252 A [0218]
- US 10335218 A [0218]
- US 10335211 A [0218]
- US 10335257 A [0218]
- US 10335217 A [0218]
- US 10335212 A [0218]
- US 10335241 A [0218]
- US 10335183 A [0218]
- US 42581503 A [0218]
- US 23726102 A [0218]
- US 42053503 A [0218]
- US 42385103 A [0218]
- US 42298802 P [0218]
- US 42442902 P [0218]
- US 494417 P [0218]
- US 60494401 P [0218]

Non-patent literature cited in the description

- Tietz Textbook of Clinical Chemistry. W.B. Saunders Company, 1999, 776-78 [0060]

专利名称(译)	用于集成分析物检测构件的体液采样的方法和设备		
公开(公告)号	EP1653849B1	公开(公告)日	2010-10-06
申请号	EP2004780949	申请日	2004-08-11
[标]申请(专利权)人(译)	佩利坎技术公司		
申请(专利权)人(译)	PELIKAN科技股份有限公司.		
当前申请(专利权)人(译)	PELIKAN科技股份有限公司.		
[标]发明人	FREEMAN DOMINIQUE M ROSS JAMES MARSOT TRAVIS LUM PAUL MAUZE GENAPATI		
发明人	FREEMAN, DOMINIQUE, M. ROSS, JAMES MARSOT, TRAVIS LUM, PAUL MAUZE, GENAPATI		
IPC分类号	A61B5/15 A61B A61B5/00		
CPC分类号	A61B5/15186 A61B5/14532 A61B5/150022 A61B5/150137 A61B5/150152 A61B5/150167 A61B5/150175 A61B5/150358 A61B5/150427 A61B5/150503 A61B5/150572 A61B5/151113 A61B5/15117 A61B5/15123 A61B5/15128 A61B5/1513 A61B5/15146 A61B5/15151 A61B5/15161 A61B5/15176 A61B5/157		
代理机构(译)	HARRIS , RICHARD IAN		
优先权	60/494417 2003-08-11 US 60/599792 2004-08-05 US 60/494401 2003-08-11 US		
其他公开文献	EP1653849A4 EP1653849A2		
外部链接	Espacenet		

摘要(译)

提供了一种体液采样装置。在一个实施例中，该装置包括包含多个穿透构件的盒和具有多个分析物检测构件的第二部分，并且其中第二部分连接到第一盒。第二部分上的分析物检测构件定位成接收由离开第一盒的一个穿透构件产生的伤口的体液。

