

(19)



(11)

**EP 1 574 166 B1**

(12)

**EUROPEAN PATENT SPECIFICATION**

(45) Date of publication and mention of the grant of the patent:  
**18.05.2016 Bulletin 2016/20**

(51) Int Cl.:  
**A61B 5/00 (2006.01) A61B 5/1455 (2006.01)**

(21) Application number: **03778822.1**

(86) International application number:  
**PCT/JP2003/015880**

(22) Date of filing: **11.12.2003**

(87) International publication number:  
**WO 2004/052211 (24.06.2004 Gazette 2004/26)**

**(54) MEASURING PROBE AND LIVING BODY OPTICAL MEASURING DEVICE**

MESSSONDE UND OPTISCHE MESSVORRICHTUNG FÜR EINEN LEBENDEN KÖRPER

SONDE DE MESURE ET DISPOSITIF DE MESURE OPTIQUE DE CORPS VIVANTS

(84) Designated Contracting States:  
**DE FR GB IT NL**

(72) Inventors:  
• **ISHIZUKA, Takashi**  
Kitasoma-gun, Ibaraki 300-1511 (JP)  
• **FUJIWARA, Michiyuki**  
Tokyo 101-0021 (JP)

(30) Priority: **12.12.2002 JP 2002360220**  
**18.07.2003 JP 2003276767**

(74) Representative: **Strehl Schübel-Hopf & Partner**  
**Maximilianstrasse 54**  
**80538 München (DE)**

(43) Date of publication of application:  
**14.09.2005 Bulletin 2005/37**

(73) Proprietor: **HITACHI MEDICAL CORPORATION**  
**Tokyo 101-0047 (JP)**

(56) References cited:  
**WO-A1-00/74562 WO-A1-96/10198**  
**JP-A- 10 085 204 JP-A- 11 004 830**

**EP 1 574 166 B1**

Note: Within nine months of the publication of the mention of the grant of the European patent in the European Patent Bulletin, any person may give notice to the European Patent Office of opposition to that patent, in accordance with the Implementing Regulations. Notice of opposition shall not be deemed to have been filed until the opposition fee has been paid. (Art. 99(1) European Patent Convention).

## Description

### TECHNICAL FIELD

**[0001]** The present invention relates to a measuring probe adapted to irradiate a subject with measurement light and receive light transmitted through the subject (living body passing light), and to a living body optical measuring device having the measuring probe.

### BACKGROUND ART

**[0002]** As disclosed, for example, in JP 9-98972 A, a conventional living body optical measuring device has a measuring probe attached to a subject and a device main body connected to the measuring probe. The measuring probe has an irradiation optical fiber for irradiating the subject with measurement light generated in the device main body, a detection optical fiber for receiving the measurement light transmitted through the subject, that is, a living body passing light, and guiding it to the device main body; a fixing member for securing the distal end portions of the irradiation and detection optical fibers at predetermined positions of the subject; and a fixation belt for securing the fixing member to the subject.

**[0003]** However, in the case, for example, of the measurement of a newborn baby or a measurement of long duration, it is necessary to perform, apart from a measurement in a seated position or a standing position, measurement in which the subject lies down, and there is demand for a measuring probe allowing such measurement. That is, there is demand for a measuring probe which can be attached to the subject without damaging the optical fibers even when the subject lies down.

**[0004]** WO 00/74562 A1 and JP 11 00 4830 A disclose optical measuring probes with the features of the pre-characterizing portion of claim 1.

### DISCLOSURE OF THE INVENTION

**[0005]** The present invention has been made with a view toward solving the above problem. It is accordingly an object of the present invention to provide a measuring probe and a living body optical measuring device which allow measurement with a subject lied down.

**[0006]** To this end, according to one aspect of the present invention, there is provided a measuring probe as defined in Claim 1. Further advantageous features are set out in the dependent claims.

**[0007]** According to another aspect of the present invention, there is provided a living body optical measuring device comprising a measuring probe as referred to above.

### BRIEF DESCRIPTION OF THE DRAWINGS

**[0008]**

Fig. 1 is a plan view of a measuring probe according to Embodiment 1 of the present invention;

Fig. 2 is sectional view of a holder portion of Fig. 1; Fig. 3 is a plan view of Fig. 2 with a holder cover removed;

Fig. 4 is a plan view of a holder base of Fig. 2;

Fig. 5 is a side view of the holder base of Fig. 4;

Fig. 6 is a sectional view taken along the line VI-VI of Fig. 4;

Fig. 7 is a bottom view of the holder base of Fig. 4;

Fig. 8 is a sectional view of the holder cover of Fig. 2;

Fig. 9 is a bottom view of the holder cover of Fig. 7;

Fig. 10 is a block diagram schematically showing the construction of a living body optical measuring device including the measuring probe of Fig. 1;

Fig. 11 is a front view of a measuring probe according to Embodiment 2 of the present invention;

Fig. 12 is a sectional view taken along the line XII-XII of Fig. 11;

Fig. 13 is a perspective view of the measuring probe of Fig. 11 with the holder cover removed therefrom;

Fig. 14 is a perspective view of the holder portion of Fig. 11 as attached to a subject;

Fig. 15 is a perspective view of the holder portion of Fig. 14 with a fastening fixing member attached thereto from above;

Fig. 16 is a plan view of a measuring probe according to Embodiment 3 of the present invention; and

Fig. 17 is a plan view of a measuring probe according to Embodiment 4 of the present invention.

### BEST MODE FOR CARRYING OUT THE INVENTION

**[0009]** In the following, preferred embodiments of the present invention will be described with reference to the drawings.

#### Embodiment 1

**[0010]** Fig. 1 is a plan view of a measuring probe according to Embodiment 1 of the present invention. In the drawing, the measuring probe of this embodiment has a probe main body 101 to be attached to a subject, a plurality of irradiation optical fibers 102 for guiding irradiation light from the main body of a measuring device to the probe main body 101, and a plurality of detection optical fibers 103 for guiding living body passing light from the subject to the main body of the measuring device.

**[0011]** Unlike the conventional measuring probes, the measuring probe of this embodiment has the irradiation and detection optical fibers 102 and 103 attached in advance to the probe main body 101. Thus, by attaching the probe main body 101 to the subject, the irradiation and detection optical fibers 102 and 103 are respectively arranged at desired measurement positions. That is, by placing the probe main body 101 on the head of the subject, the irradiation and detection optical fibers 102 and 103 are respectively arranged at desired measurement

positions.

**[0012]** One end (distal end) of each of the irradiation and detection optical fibers 102 and 103 is retained perpendicular to the surface of the subject with which the probe main body 101 is brought into contact. Also, the irradiation and detection optical fibers 102 and 103 are drawn out of a side surface of the probe main body 101. The other end of each of the irradiation and detection optical fibers 102 and 103 is connected to the measuring device main body.

**[0013]** The probe main body 101 has three holder portions 104. In each holder portion 104, three optical fiber head portions (including an irradiation bed portion and a detection bed portion) are provided at equal intervals. The holder portions 104 are connected together at predetermined intervals by connecting portions 105. As a result, the intervals between the holder portions 104 are maintained, and the measuring probe as a whole is reduced in weight and thickness.

**[0014]** Further, in order that the attachment position of the measuring probe is not shifted even if the subject moves in a horizontal position, such as a prone position, a fixing means (not shown), such as a belt, for securing the measuring probe to the head may be connected to the probe main body 101.

**[0015]** Next, Fig. 2 is a sectional view of the holder portion 104 of Fig. 1, Fig. 3 is a plan view of Fig. 2 with a holder cover removed, Fig. 4 is a plan view of a holder base shown in Fig. 2, Fig. 5 is a side view of the holder base of Fig. 4, Fig. 6 is a sectional view taken along the line VI-VI of Fig. 4, Fig. 7 is a bottom view of the holder base of Fig. 4, Fig. 8 is a sectional cover of the holder cover of Fig. 2, and Fig. 9 is a bottom view of the holder cover of Fig. 7.

**[0016]** In the drawings, placed on a holder base 201 constituting a first member is a holder cover 202 constituting a second member. The holder base 201 is arranged on the side to be brought into contact with the subject, and the holder cover 202 is arranged on the side not to be brought into contact with the subject. The holder base 201 is formed of a material more flexible than that of the holder cover 202. The holder cover 202 is formed of a material more rigid than that of the holder base 201.

**[0017]** Between the holder base 201 and the holder cover 202, there are retained three optical fibers 102 and 103. A plurality of mutually independent optical fiber arranging grooves (protecting grooves) 207 in which the optical fibers 102 and 103 are accommodated are provided in the holder base 201. Further, the optical fibers 102 and 103 are introduced into the holder portion 104 through a side surface of the holder portion 104, and extend within the holder portion 104 in the direction in which the holder portion 104 extends, with their distal end portions being bent substantially at right angles.

**[0018]** Inside the holder portion 104, there are provided a plurality of optical fiber fixing members 203 for securing the distal ends of the optical fibers 102 and 103, a plurality of optical fiber protecting members 204 for protecting the

bent portions of the optical fibers 102 and 103, and a plurality of height adjustment jigs 205 for adjusting the amount by which the optical fibers 102 and 103 protrude from the holder base 201.

**[0019]** The optical fiber fixing members 203 retain the optical fibers 102 and 103 such that the distal end portions of the optical fibers 102 and 103 are arranged at the measurement positions of the subject. Further, the optical fiber fixing members 203 have built-in spring mechanisms (not shown) which retain the optical fibers 102 and 103 and extrude them by a minute amount from the surface of the holder base 201.

**[0020]** The optical fibers 102 and 103 are arranged so as to avoid the optical fiber fixing members 203 for the other optical fibers 102 and 103. For example, the optical fiber 103 arranged at a position nearest to the introducing portion for the optical fibers 102 and 103 passes a side near a first protrusion 402a (described below) for fixing together the holder base 201 and the holder cover 202, and is bent vertically by the optical fiber protecting member 204 before being retained by the optical fiber fixing member 203. The optical fiber 102 arranged at the intermediate position passes the outer side of the optical fiber 103 closest to the introducing portion, and, after being vertically bent by the optical fiber protecting member 204, is retained by the optical fiber fixing member 203. Further, the optical fiber 103 arranged at the position farthest from the introducing portion of the above optical fibers 102 and 103 passes the side opposite to the above-mentioned two optical fibers 102 and 103 with respect to the first protrusion 402a, and is bent vertically by the optical fiber protecting member 204 before being retained by the optical fiber fixing member 203.

**[0021]** The above arrangement of the optical fibers 102 and 103 are effected by inserting the optical fibers 102 and 103 into the optical fiber arrangement grooves 207. In this process, in order to make the bending rate when bending the optical fibers 102 and 103 while protecting them by means of the optical fiber protecting members 204 as low as possible, the outer peripheral coatings of the optical fibers 102 and 103 are removed, and the core portions of the optical fibers 102 and 103 are arranged in the optical fiber arrangement grooves 207.

**[0022]** In the mating surface of the holder base 201 (the surface mated with the holder cover 202), there are provided three recesses 401 with a circular section. At the bottom of each recess 401, there is provided a through-hole 402 leading to the subject side. The distal end portions of the optical fibers 102 and 103 are protruded slightly out of the holder base 201 through the through-holes 402.

**[0023]** The recesses 401 and the through-holes 402 are arranged coaxially. The diameter of the recesses 401 is larger than the diameter of the through-holes 402. As a result, step portions are formed at the bottom of the recesses 401. Further, the diameter of the recesses 401 is the same size as the outer peripheral diameter of the height adjustment jigs 205 and of the optical fiber fixing

members 203. The height adjustment jigs 205 and the optical fiber fixation jigs 203 are inserted into the recesses 401.

**[0024]** Further, the holder base 201 has a plurality of annular protrusions 403 protruding so as to surround the distal end portions of the optical fibers 102 and 103 exposed from the holder base 201. By adjusting the amount by which the optical fibers 102 and 103 protrude with respect to the annular protrusions 403 by the height adjustment jigs 205, it is possible to adjust the pressurizing force with which the distal end portions of the optical fibers 102 and 103 abut the subject. Further, due to the annular protrusions 403, external light is prevented from entering the optical fibers 102 and 103 during measurement.

**[0025]** Further, the annular protrusions 403 are formed independently of each other and arranged so as to be spaced apart from each other. As a result, when the measuring probe is arranged on the subject, deformation of the holder portion 104 is allowed such that the annular protrusions 403 are in conformity with the measurement region (abutment region). As a result, it is possible for the optical fibers 102 and 103 to abut the subject at right angles or substantially at right angles. Further, due to the deformation in conformity with the configuration of the measurement region, external light is more reliably prevented from entering the optical fibers 102 and 103 during measurement.

**[0026]** While in this example the external configuration of the annular protrusion 403 formed at the center is circular, and the external configuration of the annular protrusion 403 arranged on either side thereof is elliptical, the configurations of the annular protrusions 403 are not restricted thereto.

**[0027]** The height adjustment jigs 205 prevent excessive burden on the optical fibers 102 and 103 when the moving amount of the optical fibers 102 and 103 at the time of attachment of the measuring probe to the subject exceeds the deformable range of the built-in spring mechanisms of the optical fiber fixing members 203. This helps to prevent the optical fibers 102 and 103 from being damaged.

**[0028]** At the longitudinal ends of the holder base 201, there are formed relatively large first protrusions 402a. Further, between (in the interval) of the recesses 401 adjacent to each other, there are formed second protrusions 402b whose section diameter and protruding amount are smaller than those of the first protrusions 402a.

**[0029]** In the mating surface of the holder cover 202 facing the holder base 201, there are formed a plurality of accommodating portions 404, which are recesses opposed to the recesses 401. The recesses 401 and the accommodating portions 404 define spaces for accommodating the bent portions of the optical fibers 102 and 103. The accommodating portions 404 accommodate the bent portions of the optical fibers 102 and 103, the optical fiber fixing members 203, and the optical fiber

protecting members 204. The size of the accommodating portions 404 is set so as to be minimum within the range not involving damage due to the bending of the optical fibers 102 and 103.

**[0030]** Further, the movement of the optical fibers 102 and 103 due to the movement of the distal end portions of the optical fibers 102 and 103 when attaching the measuring probe to the subject is absorbed by the bent portions accommodated in the accommodating portions 404. As a result, the burden on the optical fibers 102 and 103 is substantially reduced, thereby preventing the optical fibers 102 and 103 from being damaged.

**[0031]** Further, the inner peripheral surfaces of the accommodating portions 404 are formed in the same size and configuration as the outer peripheral surfaces of the optical fiber fixing members 203. That is, the accommodating portions 404 also serve as retaining means for retaining the optical fiber fixing members 203. As a result, when the measuring probe is attached to the subject, positional deviation of the optical fiber fixing members 203 is prevented, making it possible to obtain more accurate measurement results.

**[0032]** In order to make the holder cover 202 as thin as possible and to ensure a sufficient strength, protrusions are formed in those portions of the surface thereof on the opposite side of the mating surface (the portion coming into contact with a bed, etc. at the time of measurement) in which the accommodating portions 404 are formed.

**[0033]** In the holder cover 202, there are formed a plurality of grooves 405 through which part of the bent optical fibers 102 and 103 pass. The grooves 405 extend from the accommodating portions 404 in the same direction as the optical fiber arrangement grooves 207. The optical fibers 102 and 103 are partially retained in the grooves 405, whereby the optical fibers 102 and 103 are bent in minimum spaces, and the burden on the optical fibers 102 and 103 is minimized.

**[0034]** Further, in the holder cover 202, there are formed two insertion holes 406a into which the first protrusions 402a are inserted, and two joining recesses 406b into which the second protrusions 402b are fitted. By inserting the first protrusions 402a into the insertion holes 406a and by fitting the second protrusions 402b into the joining recesses 406b, the holder base 201 and the holder cover 202 are combined with each other. Further, the holder cover 202 is fixed to the holder base 201 by screws or the like.

**[0035]** Next, Fig. 10 is a block diagram schematically showing the construction of a living body optical measuring device including the measuring probe of Fig. 1. In the drawing, the living body optical measuring device has a probe main body 101, a light source portion 501, an oscillating portion 503, a plurality of photo diodes 511, a lock-in amplifier module 512, an A/D converter 516, a control portion 517, an input/output portion 502, and an image producing portion 521.

**[0036]** The light source portion 501 has a plurality of

(for example, four, as in this case) optical modules 502. Each optical module 502 has two semiconductor lasers (not shown) respectively emitting lights of a plurality of wavelengths from the visible to the infrared wavelength region, for example, dual wavelengths of 780 nm and 830 nm.

**[0037]** All the semiconductor lasers included in the light source 501 are modulated by the oscillating portion 503 composed of oscillators of different oscillation frequencies. That is, in the oscillating portion 503, the semiconductor lasers are analog-modulated by a sine wave. Further, each of the optical modules 502 is equipped with an optical fiber connector (not shown) introducing the lights of the wavelengths of 780 nm and 830 nm emitted from the semiconductor lasers into a single irradiation optical fiber 102.

**[0038]** Thus, the light consisting of a mixture of lights of two wavelengths emitted from the light source portion 501 is applied to the subject constituting the object of irradiation from the distal end portions of a plurality of irradiation optical fibers 102 connected to each of the optical modules 502. At this time, the irradiation optical fibers 102 are secured in position at the probe main body 101 as stated above, and apply light to different positions. For example, the distal end portions of the irradiation optical fibers 102 and the detection optical fibers 103 are arranged alternately in a tetragonal-lattice-like fashion inside the probe main body 101.

**[0039]** The living body passing light (the light transmitted through a light scattering reflective body) returning from the subject is detected through a plurality of (for example, five) detection optical fibers 103 arranged in the probe main body 101 by photo diodes (photo detectors) 511 connected to the other ends of the detection optical fibers 103. As the photo diodes 511, it is desirable to adopt well-known avalanche photo diodes which allow high sensitivity optical measurement.

**[0040]** The living body passing light is converted to electric signals (living body passing light intensity signals) by the photo diodes 511. Thereafter, a modulation signal corresponding to the irradiating position and wavelength is selectively detected by a modulation signal selective detection circuit, for example, a lock-in amplifier module 512 composed of a plurality of lock-in amplifiers (not shown).

**[0041]** At this time, the modulation signals output from the lock-in amplifier module 512 are ones respectively separated into living body passing light intensity signals corresponding to the wavelengths and irradiating positions. In the lock-in amplifier module 512, there are used the same number of lock-in amplifiers (not shown) as the number of signals to be measured (for example, 24).

**[0042]** The living body passing light intensity signals analog-output from the lock-in amplifier module 512 are respectively converted to digital signals by an A/D converter (analog/digital converter) 516 of a plurality of (for example, 24) channels. The digital signals are living body passing light intensity signals respectively corresponding

to the wavelengths and irradiating positions.

**[0043]** The light source portion 501, the oscillating portion 503, the lock-in amplifier module 512, and the A/D converter 516 are controlled by a control portion 517.

**[0044]** The living body passing light intensity signals converted to digital signals are recorded in a storage portion 518 provided in the image producing portion 521. The living body passing light intensity signals recorded in the storage portion 518 are read at a processing portion 519 which is also provided in the image producing portion 521. In the case of an ordinary living body optical measurement, the processing portion 519 computes changes in oxygenated hemoglobin concentration and changes in de-oxygenated hemoglobin concentration accompanying brain activity, and hemoglobin concentration total amount, based on the living body passing light intensity signals of the detecting positions. The computation results are displayed on a display screen (not shown) of the input/output portion 520 as age-based information on a plurality of measurement positions. The age-based information is stored in the storage portion 518. The method of computation by the processing portion 519 is well known in the art, so a detailed description thereof will be omitted.

**[0045]** In the living body passing light measuring device constructed as described above, the tip portions of the irradiation and detection optical fibers 102 and 103 are introduced into the probe main body 101, and are bent inside the probe main body 101 so as to be perpendicular to the skin of the subject. Thus, even when the subject is in a prone position, it is possible to perform living body optical measurement without damaging the measuring probe (in particular, the irradiation and detection optical fibers 102 and 103).

**[0046]** As a result, it is also possible to perform a living body optical measurement which takes so long as to necessitate the subject to take a rest, such as sleep, which has been difficult in a living body optical measurement using a conventional measuring probe. Thus, it is possible to accurately identify the position of a hypnic epileptic focus or the like, which has conventionally been difficult to identify, making it possible to achieve a substantial improvement in terms of therapeutic performance.

**[0047]** Further, since only the core portions of the optical fibers 102 and 103 are accommodated in the holder portion 104, it is possible to bend the optical fibers 102 and 103 at a smaller radius, making it possible to reduce the thickness of the holder portion 104. As a result, it is possible to further reduce the burden on the subject when performing measurement with the subject lied down.

**[0048]** Further, since the holder base 201 is formed of a material more flexible than that of the holder cover 202, it is possible to further reduce the burden on the subject at the time of attachment.

**[0049]** The number of holder portions 104 is not restricted to three but may be any other number.

**[0050]** Further, the number of optical fibers arranged in one holder portion 104 is not restricted to three, either,

but may be any other number.

**[0051]** Further, the routing of the optical fibers 102 and 103 in the holder portion 104 is not restricted to the above-described one.

**[0052]** Furthermore, while in this embodiment the annular protrusions 403 are formed so as to protrude from the holder base 201, this should not be construed restrictively; for example, it is also possible to form the annular recesses 403 by forming recesses extending in the minor axis direction of the holder base 201.

**[0053]** The values of the wavelengths of the lights emitted from the optical modules 502 are not restricted to 780 nm and 830 nm. Further, the number of wavelengths is not restricted to two, either.

**[0054]** Further, while in the above example a semiconductor laser is used as the light source, this should not be construed restrictively; for example, it is also possible to use a light emitting diode.

**[0055]** Furthermore, the method of modulation at the oscillating portion 503 is not restricted to the analog modulation by sine wave; it may also be, for example, a digital modulation using rectangular waves of different time intervals. When thus using digital modulation, a digital filter or a digital signal processor is used as a modulated signal detecting means.

**[0056]** Further, the photo detectors are not restricted to photo diodes; it is also possible to use other photoelectric conversion devices, such as photomultiplier tubes, as long as they are photoelectric conversion devices.

## Embodiment 2

**[0057]** Next, Fig. 11 is a front view of a measuring probe according to Embodiment 2 of the present invention, Fig. 12 is a sectional view taken along the line XII-XII of Fig. 11, and Fig. 13 is a perspective view of the measuring probe of Fig. 11 with the holder cover removed therefrom.

**[0058]** In Embodiment 2, in order to match the holder portion 104 with the head configuration of the subject, a base plate 601 as a curving means is bonded to the holder portion 104. The construction of the holder portion 104 is the same as that of Embodiment 1. The base plate 601 is formed of a hard material, such as plastic. Thus, the holder portion 104 is reinforced by the base plate 601.

**[0059]** The base plate 601 is curved in advance. The curvature of the base plate 601 is matched with the head configuration of the subject in advance. The holder portion 104 is maintained in a configuration corresponding to the curved configuration of the base plate 601. Further, the base plate 601 is constructed so as not to interfere with the annular protrusions 403 and the distal end portions of the optical fibers 102 and 103.

**[0060]** By using the base plate 601 described above, it is possible to secure the holder portion 104 in position in a state in which the holder portion 104 is in close contact with the head of the subject. Thus, there is no fear of any undesired gap being generated between the head of the subject and the holder portion 104, making it pos-

sible to achieve an improvement in terms of measurement sensitivity.

**[0061]** Further, although not shown, it is also possible to provide rails on the subject side of the holder portion 104, holding the base plate 601 between the rails. This makes it possible to replace the base plate 601 and to combine the relatively soft holder portion 104 with base plates 601 of various configurations, making it possible to modify and attach the holder portion 104 in an optimum manner in conformity with various subject head configurations.

**[0062]** Fig. 14 is a perspective view of the holder portions 104 of Fig. 11 as attached to the subject, and Fig. 15 is a perspective view of the holder portions 104 of Fig. 14 with a fastening fixing member 701 attached from above.

**[0063]** The holder portions 104 are combined with base plates 601 of configurations corresponding to their respective attachment positions. This makes it possible for the holder portions 104 to be fixed in an optimum conformity with the head, which exhibits a fine variation in configuration from position to position.

**[0064]** Further, by attaching the tube-shaped fastening fixing member 701 surrounding the subject, it is possible to prevent the holder portions 104 from being detached, and to hold the holder portions 104 in close contact with the subject. As the material of the fastening fixing member 701, it is possible to use an elastic cloth, a ring-like balloon adapted to expand through injection of air, etc.

**[0065]** The base plates 601 are equipped with connecting portions 602 for the connection of the adjacent base plates 601. The connecting portions 602 may be, for example, of the type in which protrusions and holes are joined with each other or of the type in which attachment is effected by using magnets. This helps to prevent the individual holder portions 104 from being detached.

**[0066]** Further, a connection hole 603 is provided at an end of each base plate 601. It is possible to connect a chin strap or belt (not shown) for the subject to the connection hole 603 as needed.

**[0067]** While in Embodiment 2 the base plate 601 and the holder base 201 are separate from each other, it is also possible to mold the base plate 601 and the holder base 201 integrally with each other.

**[0068]** Further, the base plate may be formed of a material which allows free manual curving and maintenance of the curved state. This makes it possible to perform attachment with the holder portions deformed in an optimum fashion in conformity with various subject head configurations without having to replace the base plates. In this case, the holder portions are formed of a material more flexible than that of the base plates, and are curved in conformity with the curving of the base plates without hindering the maintenance of the curved state of the base plates.

Embodiment 3

[0069] Next, Fig. 16 is a plan view of a measuring probe according to Embodiment 3 of the present invention. While in Embodiment 1 a plurality of holder portions 104 are connected by the connecting portions 105, in Embodiment 3, a plurality of holder portions 104 are previously formed into an integral unit. In this case, at least either the holder bases 201 or the holder covers 202 adopt an integral structure.

[0070] Due to this construction, it is possible to achieve a reduction in the number of parts, and to more reliably prevent mutual positional deviation of the holder portions 104.

Embodiment 4

[0071] Next, Fig. 17 is a plan view of a measuring probe according to Embodiment 4 of the present invention. In this embodiment, the measuring probe as a whole is formed such that the distal end portions of the irradiation optical fibers 102 and the distal end portions of the detection optical fibers 103 are arranged alternately in both the longitudinal direction of the holder portions 104 (the horizontal direction in Fig. 17) and the direction perpendicular to the longitudinal direction of the holder portions 104. Further, a fixed distance is maintained between the adjacent holder portions 104 by the connecting portions 105.

[0072] In the measuring probe described above, the distal end portions of the optical fibers 102 and 103 are arranged in a tetragonal-lattice-like fashion, and the distal end portions of the irradiation optical fibers 102 and the distal end portions of the detection optical fibers 103 are arranged alternately in both of the two directions perpendicular to each other, whereby it is possible to realize a more effective measurement.

Claims

1. A measuring probe comprising:

a holder portion (104) attached to a subject; and a plurality of optical fibers (102, 103) for irradiation and detection whose distal end portions on a subject side are retained by the holder portion, wherein the optical fibers are led out from a side surface of the holder portion and are bent inside the holder portion such that the distal end portions are directed to the subject when the holder portion is attached to the subject, and

characterized in that

each of the optical fibers has a core portion and a peripheral coating,

the holder portion has a first member (201) to be brought into contact with the subject and a second member (202) combined with the first member, the first member being more flexible and less rigid than the second member, protecting grooves (207) into which the optical fibers are inserted, are formed in at least one of the first member and the second member, and each protecting groove accommodates a bent portion of one of the optical fibers, the bent portion consisting only of the core portion of the optical fiber and not of the peripheral coating.

- 2. The measuring probe according to Claim 1, wherein the holder portion (104) is provided with through-holes (402) through which the distal end portions of the optical fibers (102, 103) are exposed and annular protrusions (403) protruding so as to surround the distal end portions of the respective optical fibers.
- 3. The measuring probe according to Claim 1, wherein space portions for accommodating the bent portions of the optical fibers (102, 103) are provided inside the holder portion (104).
- 4. The measuring probe according to Claim 3, wherein the space portions are formed by combining recesses respectively provided in the first and second members (201, 202).
- 5. The measuring probe according to Claim 1, wherein optical fiber fixing members (203) for fixing the distal end portions of the optical fibers (102) are arranged in the holder portion (104).
- 6. The measuring probe according to Claim 5, wherein space portions for accommodating the bent portions of the optical fibers (102, 103) and the optical fiber fixing members (203) are provided in the holder portion (104), and wherein a diameter of the space portions is of the same size as an outer peripheral diameter of the optical fiber fixing members.
- 7. The measuring probe according to Claim 4, wherein the optical fiber fixing members (203) have spring mechanisms which extrude the respective optical fibers (102, 103) by a minute amount to an exterior of the holder portion (104) while retaining the optical fibers.
- 8. The measuring probe according to Claim 1, wherein optical fiber protecting members (204) for protecting the bent portions of the optical fibers are arranged inside the holder portion (104).
- 9. The measuring probe according to Claim 1, wherein a height adjustment jigs (205) for adjusting an amount by which the optical fibers (102, 103) pro-

trude from the holder portion (104) are arranged inside the holder portion.

10. The measuring probe according to Claim 1, further comprising a curving means (601) provided on the holder portion (104), for maintaining the holder portion in a configuration curved along the subject. 5
11. The measuring probe according to Claim 10, wherein the curving means (601) is mounted to the subject side of the holder portion (104) and is a base plate curved in advance. 10
12. The measuring probe according to Claim 10, wherein the curving means (601) is replaceable with respect to the holder portion (104). 15
13. The measuring probe according to Claim 10, wherein the curving means (601) is provided with a connecting portion (602) for connection with an adjacent curving means. 20
14. The measuring probe according to any one of the preceding claims, further comprising a plurality of holder portions (104), wherein, in each of the holder portions, the distal end portions of the plurality of optical fibers (102, 103) are arranged at intervals, and wherein the optical fibers are led out from a side surface of the holder portion. 25
15. The measuring probe according to any one of claims 1 to 13, further comprising a fastening fixing member (701) which is adapted to be put on the subject from above the measuring probe so as to surround the subject and which is adapted to prevent the measuring probe from being detached from the subject. 30

#### Patentansprüche 40

1. Messsonde, umfassend:

einen Halteabschnitt (104), der an einem Subjekt angebracht ist, und  
mehrere optische Fasern (102, 103) zum Beleuchten und Detektieren, deren distale Endabschnitte auf einer Seite des Subjekts vom Halteabschnitt zurückgehalten werden,  
wobei die optischen Fasern aus einer Seitenfläche des Halteabschnitts herausgeführt sind und innerhalb des Halteabschnitts gebogen sind, so dass die distalen Endabschnitte auf das Subjekt gerichtet sind, wenn der Halteabschnitt am Subjekt angebracht ist, und 50

**gekennzeichnet dadurch dass,**

jede der optischen Fasern einen Kernabschnitt und eine Randummantelung aufweist, der Halteabschnitt ein erstes Element (201), das mit dem Subjekt in Kontakt gebracht werden soll, und ein zweites Element, das mit dem ersten Element kombiniert ist, aufweist, wobei das erste Element flexibler und weniger starr als das zweite Element ist, Schutznuten (207), in die die optischen Fasern eingefügt sind, in mindestens einem des ersten und des zweiten Elements gebildet sind, und jede Schutznut einen gebogenen Abschnitt einer der optischen Fasern aufnimmt, wobei der gebogene Abschnitt lediglich aus dem Kernabschnitt der optischen Faser und nicht der Randummantelung besteht.

2. Messsonde nach Anspruch 1, wobei der Halteabschnitt (104) mit Durchgangslöchern (402), durch die die distalen Endabschnitte der optischen Fasern (102, 103) freigelegt sind, und ringförmige Vorsprünge (403), die so hervorspringen, dass sie die distalen Endabschnitte der jeweiligen optischen Fasern umgeben, ausgestattet ist.
3. Messsonde nach Anspruch 1, wobei Raumabschnitte zum Aufnehmen der gebogenen Abschnitte der optischen Fasern (102, 103) innerhalb des Halteabschnitts (104) vorgesehen sind.
4. Messsonde nach Anspruch 3, wobei die Raumabschnitte durch Kombinieren von jeweils in dem ersten und dem zweiten Element. (201, 202) vorgesehenen Aussparungen gebildet sind.
5. Messsonde nach Anspruch 1, wobei Fixierungselemente (203) für optische Fasern zum Fixieren der distalen Endabschnitte der optischen Fasern (102) im Halteabschnitt (104) angeordnet sind.
6. Messsonde nach Anspruch 5, wobei Raumabschnitte zum Aufnehmen der gebogenen Abschnitte der optischen Fasern (102, 103) und Fixierungselemente (203) für optische Fasern im Halteabschnitt (104) vorgesehen sind und wobei ein Durchmesser der Raumabschnitte von der gleichen Größe wie ein äußerer Raddurchmesser der Fixierungselemente für optische Fasern ist.
7. Messsonde nach Anspruch 4, wobei die Fixierungselemente (203) für optische Fasern Federmechanismen aufweisen, die die jeweiligen optischen Fasern (102, 103) ein kleines Stück ins Äußere des Halteabschnitts (104) drücken, während sie die optischen Fasern zurückhalten. 55
8. Messsonde nach Anspruch 1, wobei Schutzelemente (204) für optische Fasern zum Schützen der ge-

bogenen Abschnitte der optischen Fasern innerhalb des Halteabschnitts (104) angeordnet sind.

9. Messsonde nach Anspruch 1, wobei Höhenjustierungseinrichtungen (205) zum Justieren eines Maßes, in dem die optischen Fasern (102, 103) aus dem Halteabschnitt (104) herausragen, innerhalb des Halteabschnitts angeordnet sind. 5
10. Messsonde nach Anspruch 1, ferner umfassend eine Krümmungseinrichtung (601), die auf dem Halteabschnitt (104) vorgesehen ist, zum Erhalten des Halteabschnitts in einer entlang des Subjekts gekrümmten Stellung. 10
11. Messsonde nach Anspruch 10, wobei die Krümmungseinrichtung (601) auf der Seite des Subjekts des Halteabschnitts (104) angebracht ist und eine zuvor gekrümmte Grundplatte ist. 15
12. Messsonde nach Anspruch 10, wobei die Krümmungseinrichtung (601) bezüglich des Halteabschnitts (104) ersetzbar ist. 20
13. Messsonde nach Anspruch 10, wobei die Krümmungseinrichtung (601) mit einem Verbindungsabschnitt (602) zur Verbindung mit einer angrenzenden Krümmungseinrichtung ausgestattet ist. 25
14. Messsonde nach einem der vorherigen Ansprüche, ferner umfassend mehrere Halteabschnitte (104), wobei in jedem der Halteabschnitte die distalen Endabschnitte der mehreren optischen Fasern (102, 103) in Intervallen angeordnet sind und wobei die optischen Fasern aus einer Seitenfläche des Halteabschnitts herausgeführt sind. 30
15. Messsonde nach einem der Ansprüche 1 bis 13, ferner umfassend ein Befestigungselement (701), das dazu ausgelegt ist, von oberhalb der Messsonde auf das Subjekt gesetzt zu werden, um so das Subjekt zu umgeben, und das dazu ausgelegt ist, die Messsonde daran zu hindern, sich vom Subjekt zu lösen. 35

## Revendications

1. Sonde de mesure comprenant :

une partie de retenue (104) fixée sur un sujet ; et une pluralité de fibres optiques (102, 103) d'irradiation et de détection dont des parties d'extrémité distale situées sur un côté du sujet sont retenues par la partie de retenue, dans laquelle les fibres optiques sortent d'une face latérale de la partie de retenue et sont courbées à l'intérieur de la partie de retenue de sorte

que les parties d'extrémité distale sont dirigées vers le sujet lorsque la partie de retenue est fixée sur le sujet, et

## caractérisée en ce que

chacune des fibres optiques comporte une partie âme et un revêtement périphérique, la partie de retenue comporte un premier membre (201) destiné à venir en contact avec le sujet et un second membre (202) associé au premier membre, le premier membre étant plus flexible et moins rigide que le second membre, des rainures de protection (207) dans lesquelles les fibres optiques sont insérées, sont formées dans au moins l'un du premier membre et du second membre, et chaque rainure de protection loge une partie courbée d'une des fibres optiques, la partie courbée étant constituée uniquement de la partie âme et non du revêtement périphérique.

2. Sonde de mesure selon la revendication 1, dans laquelle la partie de retenue (104) est munie de trous de passage (402) à travers lesquels les parties d'extrémité distale des fibres optiques (102, 103) sont exposées et de saillies annulaires (403) faisant saillie de manière à entourer les parties d'extrémité distale des fibres optiques respectives.
3. Sonde de mesure selon la revendication 1, dans laquelle des parties formant espace destinées à loger les parties courbées des fibres optiques (102, 103) sont prévues à l'intérieur de la partie de retenue (104).
4. Sonde de mesure selon la revendication 3, dans laquelle les parties formant espace sont formées en combinant des cavités prévues respectivement dans les premier et second membres (201, 202).
5. Sonde de mesure selon la revendication 1, dans laquelle des éléments de fixation (203) de fibre optique destinés à fixer les parties d'extrémité distale des fibres optiques (102) sont disposés dans la partie de retenue (104).
6. Sonde de mesure selon la revendication 5, dans laquelle des parties formant espace destinées à loger les parties courbées des fibres optiques (102, 103) et les éléments de fixation (203) de fibre optique sont prévus dans la partie de retenue (104), et dans laquelle un diamètre des parties formant espace a la même dimension qu'un diamètre périphérique extérieur des éléments de fixation de fibre optique.
7. Sonde de mesure selon la revendication 4, dans laquelle les éléments de fixation (203) de fibre optique

comportent des mécanismes élastiques qui font sortir les fibres optiques respectives (102, 103) d'une valeur minime vers l'extérieur de la partie de retenue (104) tout en retenant les fibres optiques.

5

- 8.** Sonde de mesure selon la revendication 1, dans laquelle des éléments de protection (204) de fibre optique destinés à protéger les parties courbées des fibres optiques sont disposés à l'intérieur de la partie de retenue (104). 10
- 9.** Sonde de mesure selon la revendication 1, dans laquelle des gabarits de réglage de hauteur (205) pour régler la valeur à laquelle les fibres optiques (102, 103) font saillie de la partie de retenue (104) sont disposés à l'intérieur de la partie de retenue. 15
- 10.** Sonde de mesure selon la revendication 1, comprenant en outre un moyen de courbage (601) prévu sur la partie de retenue (104), pour maintenir la partie de retenue dans une configuration courbée le long du sujet. 20
- 11.** Sonde de mesure selon la revendication 10, dans laquelle le moyen de courbage (601) est monté au niveau du côté sujet de la partie de retenue (104) et est une plaque de base courbée au préalable. 25
- 12.** Sonde de mesure selon la revendication 10, dans laquelle le moyen de courbage (601) peut être remplacé par rapport à la partie de retenue (104). 30
- 13.** Sonde de mesure selon la revendication 10, dans laquelle le moyen de courbage (601) est muni d'une partie de connexion (602) pour être connecté à un moyen de courbage adjacent. 35
- 14.** Sonde de mesure selon l'une quelconque des précédentes revendications, comprenant en outre une pluralité de parties de retenue (104), 40  
dans laquelle, dans chacune des parties de retenue, les parties d'extrémité distale de la pluralité de fibres optiques (102, 103) sont disposées par intervalles, et dans laquelle les fibres optiques sortent d'une face latérale de la partie de retenue. 45
- 15.** Sonde de mesure selon l'une quelconque des revendications 1 à 13, comprenant en outre un élément de montage de fixation (701) qui est adapté pour être placé sur le sujet par dessus la sonde de mesure de manière à entourer le sujet et qui est adapté pour empêcher que la sonde de mesure se détache du sujet. 50

55

FIG. 1

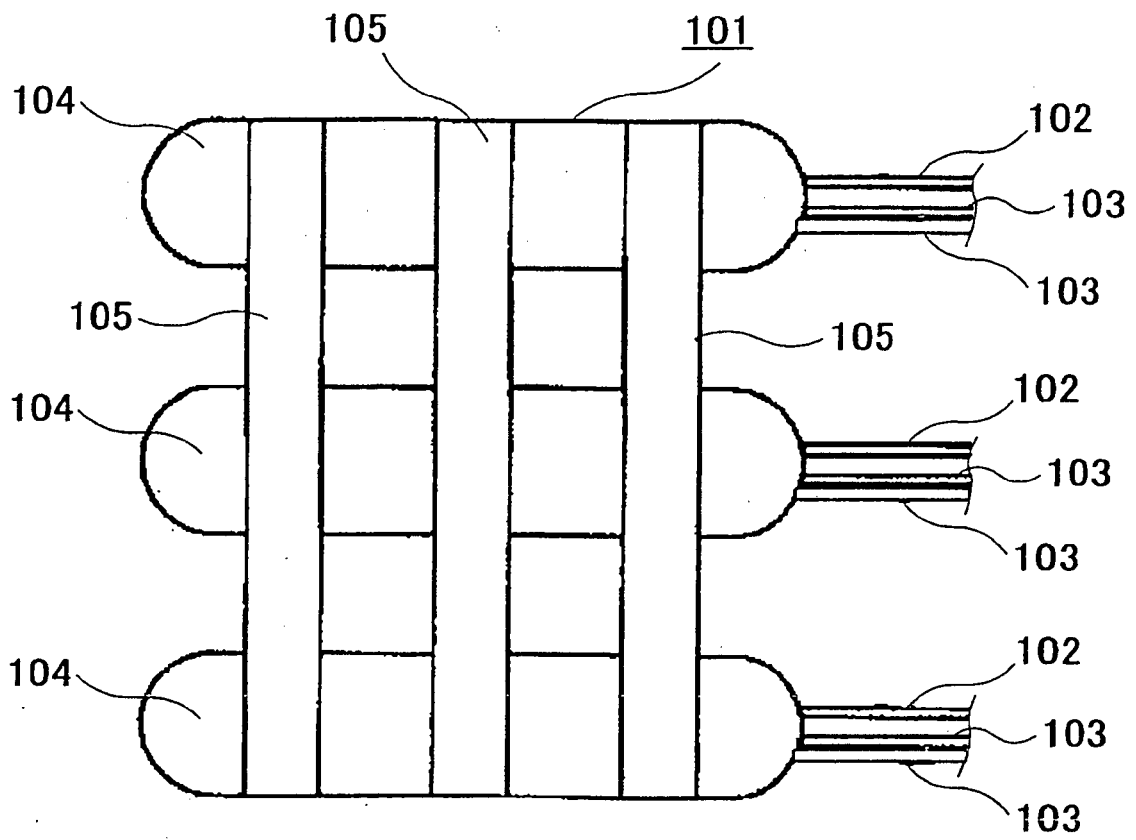

FIG. 2

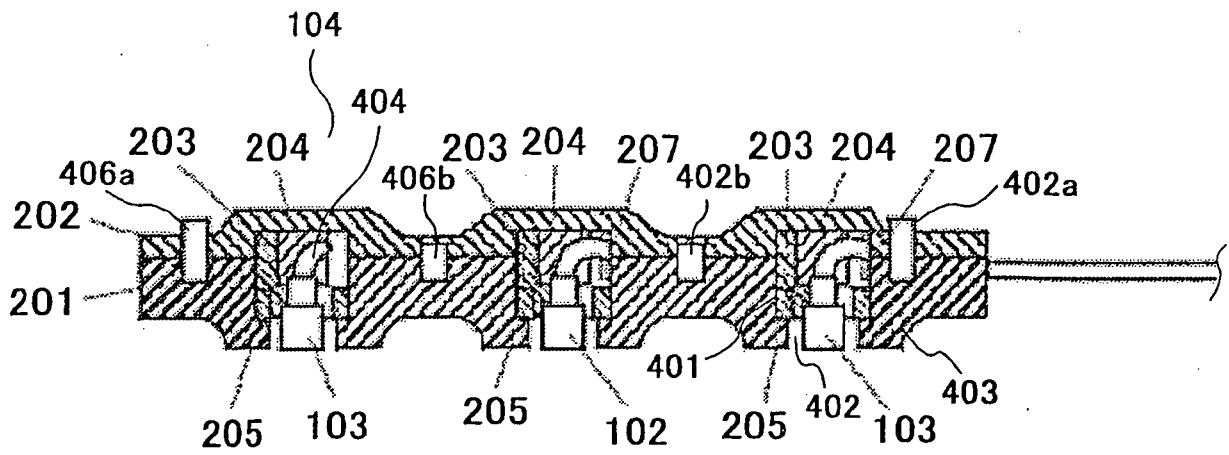

FIG. 3

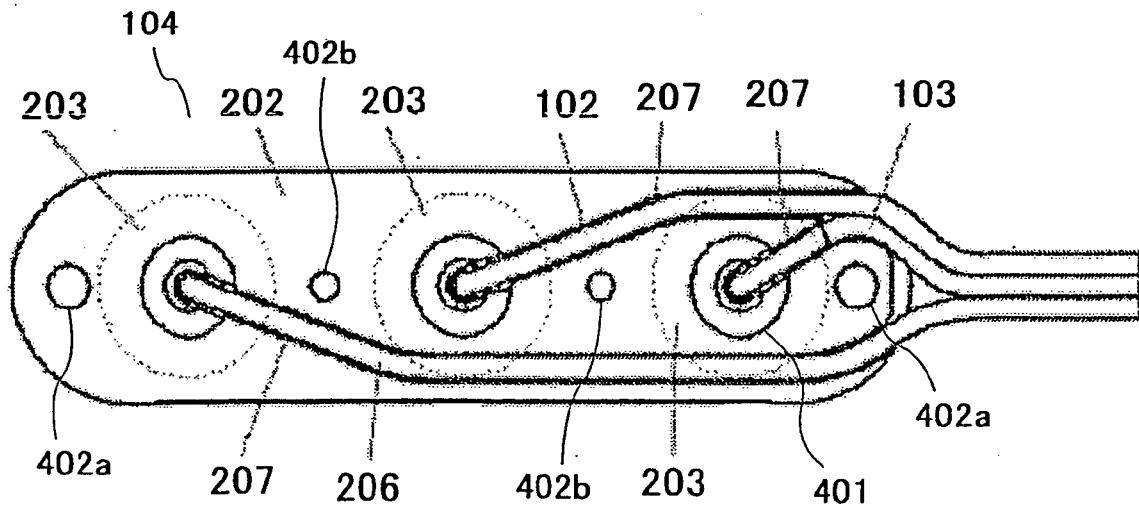

FIG. 4

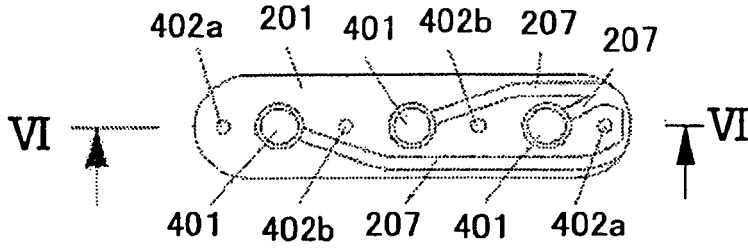

FIG. 5

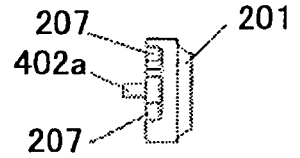

FIG. 6

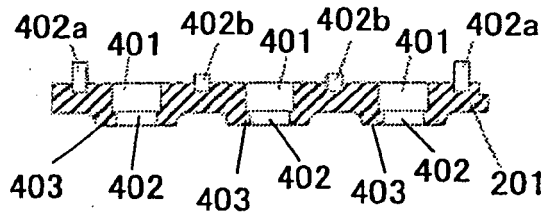

FIG. 7

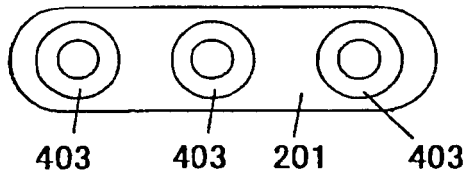

FIG. 8

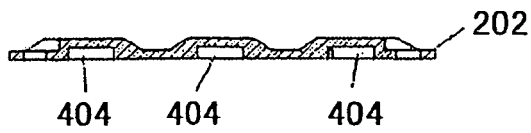

FIG. 9

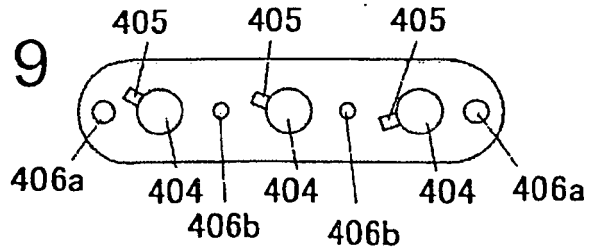

FIG. 10

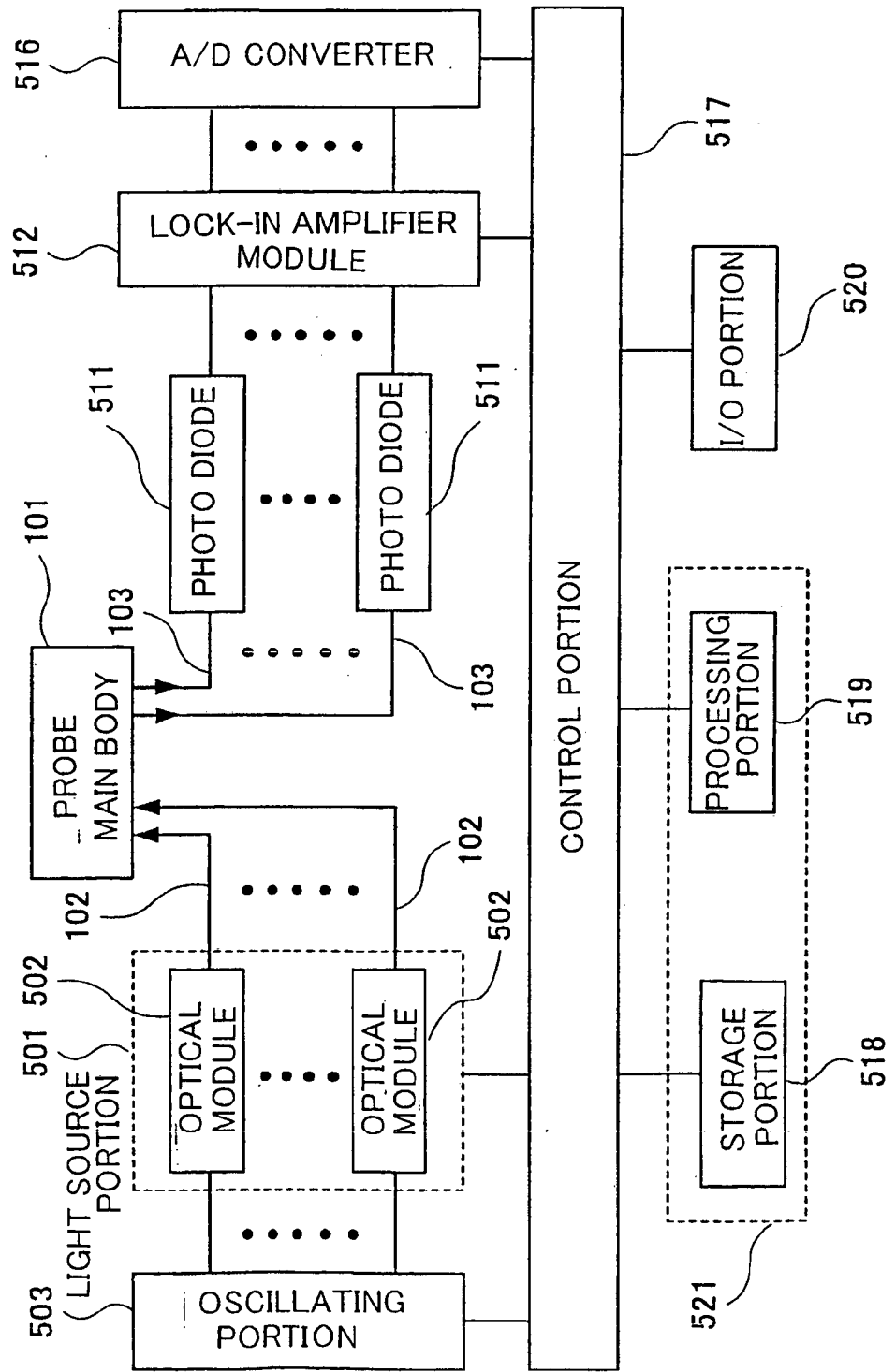

FIG. 11

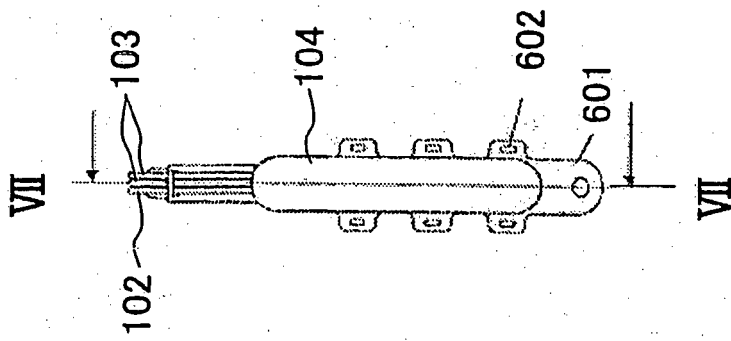

FIG. 12

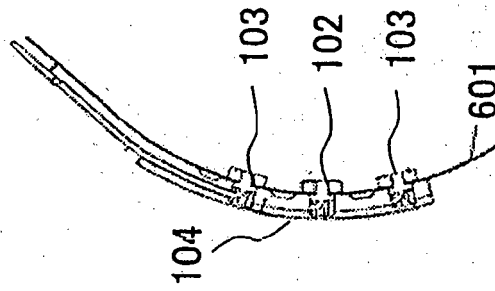

FIG. 13

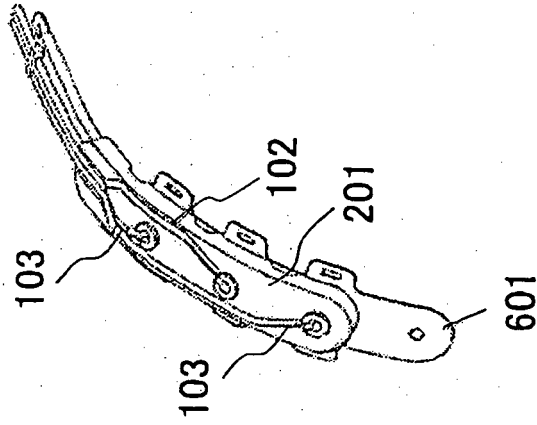

FIG. 15

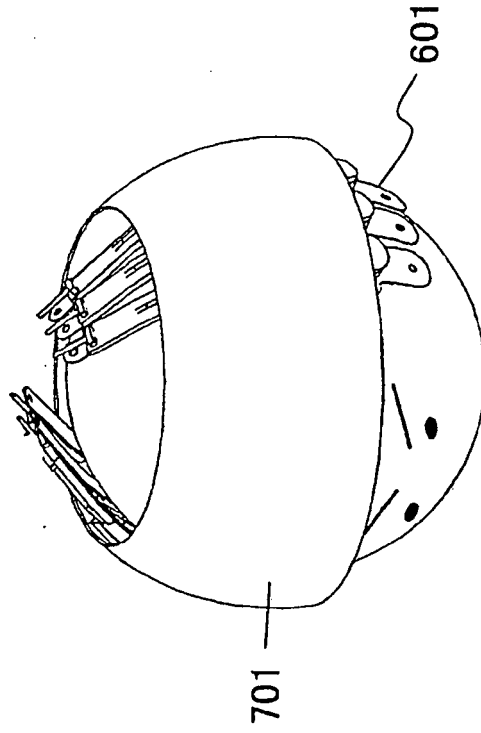

FIG. 14

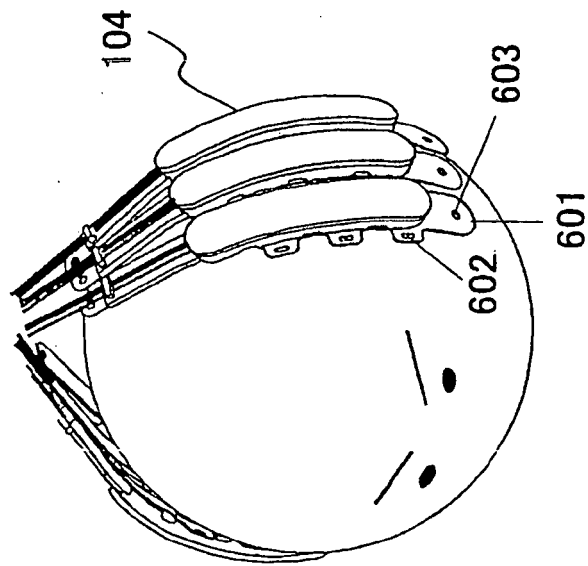

FIG. 16

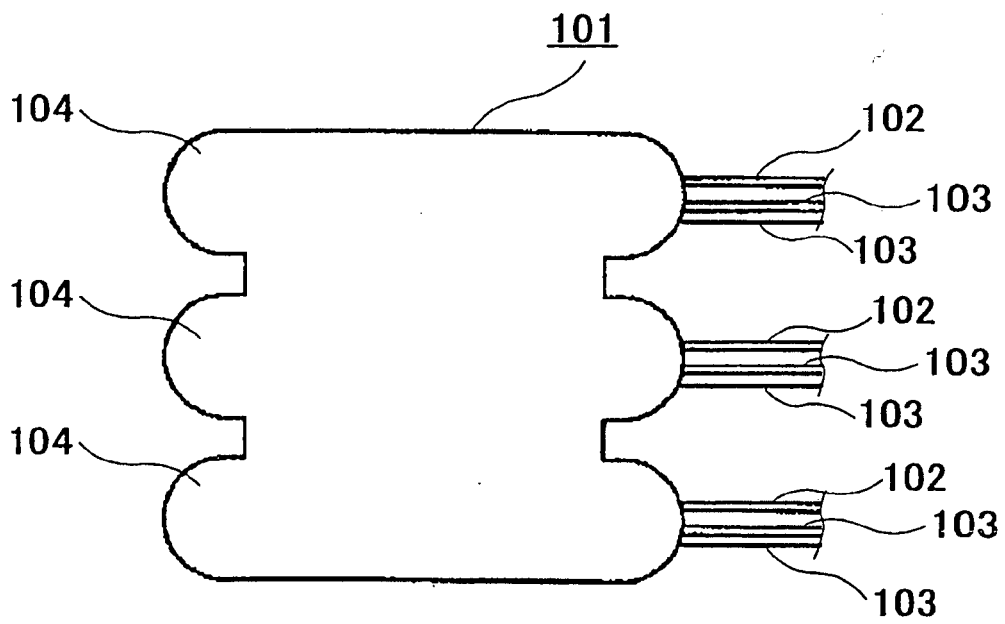
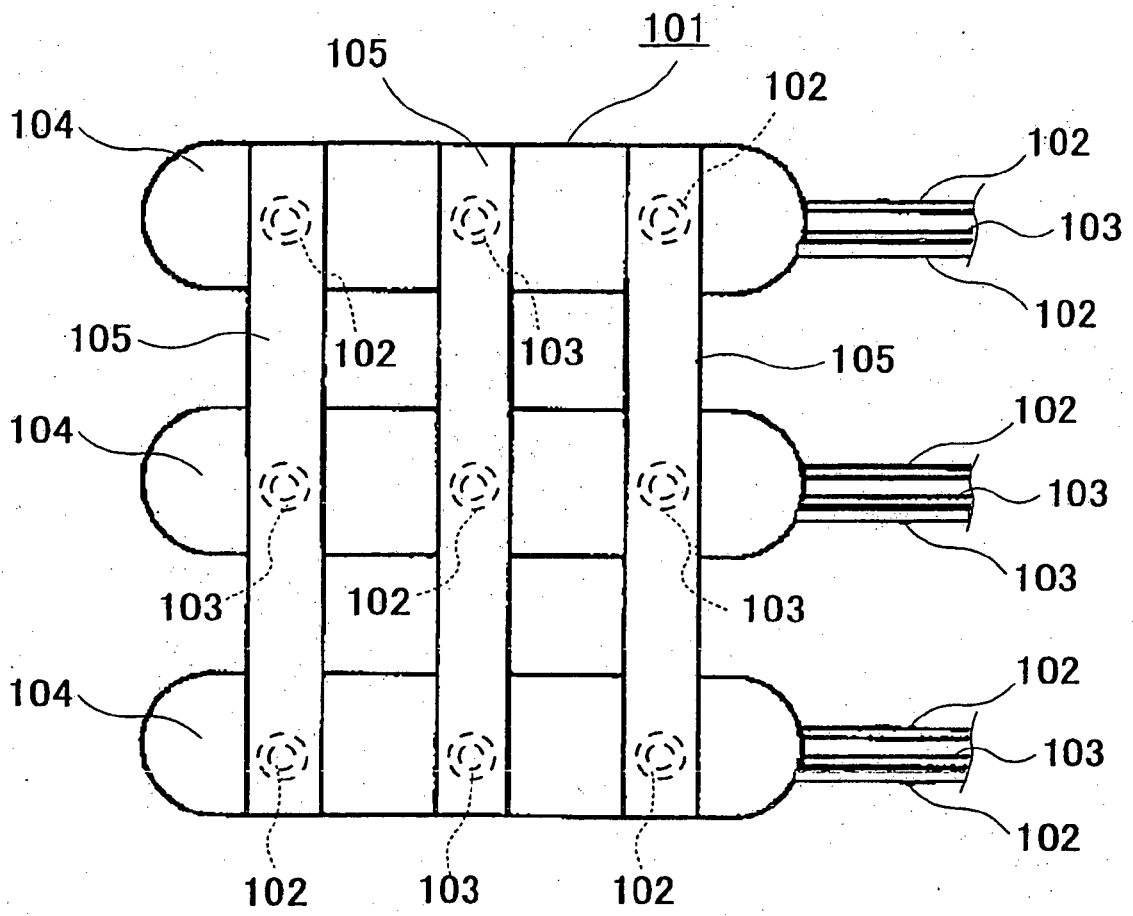

FIG. 17



**REFERENCES CITED IN THE DESCRIPTION**

*This list of references cited by the applicant is for the reader's convenience only. It does not form part of the European patent document. Even though great care has been taken in compiling the references, errors or omissions cannot be excluded and the EPO disclaims all liability in this regard.*

**Patent documents cited in the description**

- JP 9098972 A [0002]
- WO 0074562 A1 [0004]
- JP 11004830 A [0004]

专利名称(译)	测量探头和生物体光学测量装置		
公开(公告)号	<a href="#">EP1574166B1</a>	公开(公告)日	2016-05-18
申请号	EP2003778822	申请日	2003-12-11
[标]申请(专利权)人(译)	株式会社日立医药		
申请(专利权)人(译)	日立医疗器械股份有限公司		
当前申请(专利权)人(译)	日立医疗器械股份有限公司		
[标]发明人	ISHIZUKA TAKASHI FUJIWARA MICHİYUKI		
发明人	ISHIZUKA, TAKASHI FUJIWARA, MICHİYUKI		
IPC分类号	A61B5/00 A61B5/1455 A61B5/145 A61B10/00 G01N21/27 G01N21/35 G01N21/359		
CPC分类号	A61B5/0059 A61B5/14552		
优先权	2003276767 2003-07-18 JP 2002360220 2002-12-12 JP		
其他公开文献	EP1574166A4 EP1574166A1		
外部链接	<a href="#">Espacenet</a>		

摘要(译)

在测量探针中，照射光纤的远端和对象侧的检测光纤由待安装在对象上的支架部分保持。光纤从支架部分的侧表面引出。此外，光纤在支架部分中弯曲，使得当支架部分安装在对象上时，光纤的远端指向对象。

FIG. 13

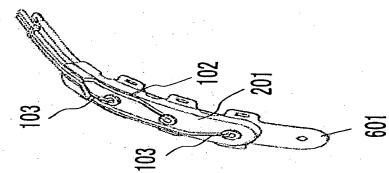

FIG. 12

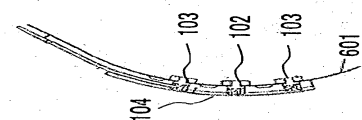

FIG. 11

