



(11) **EP 1 347 416 B1**

(12) **EUROPEAN PATENT SPECIFICATION**

(45) Date of publication and mention of the grant of the patent:
28.04.2010 Bulletin 2010/17

(51) Int Cl.:
G06T 5/40 (2006.01)

(21) Application number: **02100181.3**

(22) Date of filing: **22.02.2002**

(54) **Gradation processing method**

Gradationsverarbeitungsmethode

Procédé pour le traitement par gradation d'une image

(84) Designated Contracting States:
DE FR GB

(43) Date of publication of application:
24.09.2003 Bulletin 2003/39

(73) Proprietor: **Agfa HealthCare NV**
2640 Mortsel (BE)

(72) Inventor: **Vuylsteke, Pieter**
Septestraat 27
B-2640 Mortsel (BE)

(74) Representative: **Theunis, Patrick et al**
Agfa-Gevaert N.V.
HE / Intellectual Property 3802
Septestraat 27
2640 Mortsel (BE)

(56) References cited:
EP-A- 0 549 009 US-A- 5 151 947
US-A- 5 164 993 US-A- 5 617 313

EP 1 347 416 B1

Note: Within nine months of the publication of the mention of the grant of the European patent in the European Patent Bulletin, any person may give notice to the European Patent Office of opposition to that patent, in accordance with the Implementing Regulations. Notice of opposition shall not be deemed to have been filed until the opposition fee has been paid. (Art. 99(1) European Patent Convention).

Description

FIELD OF THE INVENTION

5 **[0001]** The present invention relates to image processing of digital medical images. More particularly the invention relates to a gradation processing method that is applicable to images of different types, such as images of different examination types.

BACKGROUND OF THE INVENTION

10 **[0002]** Nowadays several medical image acquisition techniques and systems exist that render a digital signal representation of a medical image, e.g. a radiographic image.

[0003] One example of such a system is a computed radiography system wherein a radiation image is recorded on a temporary storage medium, more particularly a photostimulable phosphor screen. In such a system a digital signal representation is obtained by scanning the screen with radiation of (a) wavelength(s) within the stimulating wavelength range of the phosphor and by detecting the light emitted by the phosphor upon stimulation.

[0004] Other examples of computed radiography systems are direct radiography systems, for example systems wherein a radiographic image is recorded in a solid state sensor comprising a radiation sensitive layer and a layer of electronic read out circuitry.

20 **[0005]** Still another example of a computed radiography system is a system wherein a radiographic image is recorded on a conventional x-ray film and wherein that film is developed and subsequently subjected to image scanning.

[0006] Still other systems such as a tomography system may be envisaged.

[0007] The digital image representation of the medical image acquired by one of the above systems can then be used for generating a visible image on which the diagnosis can be performed. For this purpose the digital signal representation is applied to a hard copy recorder or to a display device.

25 **[0008]** Commonly the digital signal representation of the image is subjected to image processing prior to hard copy recording or display.

[0009] In order to convert the digital image information optimally into a visible image on a medium on which the diagnosis is performed, a multi-resolution image processing method (also called multi scale image processing method) has been developed by means of which the contrast of an image is enhanced.

30 **[0010]** According to this multi-resolution image processing method an image represented by an array of pixel values is processed by applying the following steps. First the original image is decomposed into a sequence of detail images at multiple scales and a residual image at a scale lower than the minimum of said multiple scales. Next, the pixel values of the detail images are modified by applying to these pixel values at least one non-linear monotonically increasing odd conversion function with a slope that gradually decreases with increasing argument values. Finally, a processed image is computed by applying a reconstruction algorithm to the residual image and the modified detail images, the reconstruction algorithm being such that if it were applied to the residual image and the detail images without modification, then the original image or a close approximation thereof would be obtained.

35 **[0011]** The above image processing technique has been described extensively in European patent EP 527 525, the processing being referred to as MUSICA image processing (MUSICA is a registered trade name of Agfa-Gevaert N.V.).

[0012] The described method is advantageous over conventional image processing techniques such as unsharp masking etc. because it increases the visibility of subtle details in the image and because it increases the faithfulness of the image reproduction without introducing artefacts.

40 **[0013]** Prior to being applied to a hard copy recorder or to a display device the image signal representing the radiation image (whether or not having been subjected to the above-described contrast enhancement processing) is subjected to a signal-to-density conversion according to a conversion curve, referred to as gradation (processing) curve.

[0014] The conversion of pixels to output values suitable for reproduction or display comprises the selection of a relevant sub-range and the conversion of data in this sub-range according to a specific gradation processing curve.

45 **[0015]** Preferably the relevant sub-range and the curve to be applied are adapted to the object and to the examination type so that optimal and constant image quality can be guaranteed.

[0016] Commonly one of a set of gradation curves, created and stored in advance, is selected upon entry of data concerning the type of image to be processed, e.g. upon entry of an indication on the examination type.

50 **[0017]** Due to the large number of degrees of freedom and the large number of parameters that can be set, many gradation curves suitable for different types of applications can be defined. However, storage of a large number of gradation curves demands for a lot of storage capacity.

55 **[0018]** In European patent specification EP 0 110 185 this problem has been dealt with. A method has been disclosed for obtaining a number of different gradation curves from one of about ten basic gradation curves by rotating and parallel shifting one of the basic gradation curves. The manipulation of the basic gradation curve depends on object parameters,

radiation source parameters, examination type etc.

[0019] European patent 549 009 discloses a method wherein a gradation curve is defined by means of a set of image specific parameters. The gradation curve is deduced from a canonical form taking into account several parameters such as minimum and maximum signal level, maximum density etc. The canonical form as well as these parameters depend on the examination type of the read out image. The disclosed method thus requires input on the examination type of the read out image.

[0020] The state of the art workflow was commonly as follows.

[0021] A digital representation of a radiation image acquired by an image acquisition system as described higher is applied to an image-processing module together with a code indicative of the examination type. In the image processing module parameter settings for different examination types and examination sub-types, identifiable by means of a code, are stored in advance for example in the form of a look up table. Upon entry of a code, the parameters corresponding with the examination type identified by the code are retrieved from the look up table and the image processing including the gradation processing is controlled by the retrieved parameter settings.

[0022] Determining the optimal parameter values for each examination type is highly time-consuming because before a set of processing parameters can be accepted for a certain examination type, this set of parameters has to be evaluated on a large number of test images of that specific examination type.

[0023] The number of individual examination types is rather large since for each anatomic region (e.g. thorax) a number of examination subtypes exist (bed, paediatric, etc.).

[0024] Hence the total number of parameters to be determined is large.

[0025] In most large hospitals a centralised, radiology specific information system (RIS) is available so that the information on the examination type can be sent via this RIS.

[0026] If such a system is not available, the information on the examination type must be entered manually into an identification system. This kind of identification is more error prone than the RIS system.

[0027] In the former years the use of computed radiography systems was to a large extent limited to large radiography centres in the western market. Nowadays more smaller hospitals and private practices started to use digital systems. In addition also in non-industrialised regions computed radiography is gaining importance.

[0028] The adjustment and control of the image processing parameters demands for extensive knowledge of medical applications, which knowledge is often not available in or too expensive for these smaller and/or less industrialised centres.

[0029] The fact that in prior art methods the processing parameters had to be determined in advance and had to be fed to the processing apparatus thus constitutes a drawback of prior art methods.

[0030] Another drawback of the prior art methods is related to the detection of collimation borders.

[0031] In the prior art the selection of the relevant sub-range for conversion according to a gradation curve was performed on the basis of the image histogram. Pixels belonging to the collimation borders were not considered. Therefore it was required to detect the collimation borders in advance.

[0032] Because of the wide diversity of images and the complexity of this problem, a certain percentage of failures is inevitable (around 1%). As a consequence the correct operation of the detection of the relevant signal range is affected.

[0033] US 5, 164, 993 discloses a method and apparatus for automatically and adaptively generating optimum tonescale transformations for digital radiographic images based on an analysis of the image histogram. An improvement of the method additionally uses information about the examination type being processed to produce a tonescale that is better customized for a given input.

[0034] This method still relies on a calculation of the collimated area, more specifically the border between the true direct x-ray background and the anatomy is determined.

[0035] US patent US-A- 4, 276, 473 issued June 30, 1981 also relates to the conversion of digital signal values representing a radiological image into corresponding density values. The level of the electric signal is converted in such a way that the maximum value of the electric signal corresponding to the maximum density of the radiation image is converted into a level resulting in a given optical density value of the reproduced image on the recording material. The minimum level corresponding to the minimum density is converted to a level resulting in the fog density of the recording material. Hence a signal range which is entirely dependent on the read out image is mapped onto a fixed density range. Consequently, when the latitude of the read out signal range varies, for example because the fysionomy of the exposed patients varies, the average contrast in the reproductions will also vary. There is no control of the variation of the contrast obtained in the reproductions of images with different information content.

OBJECTS OF THE INVENTION

[0036] It is an object of the present invention to provide a method of creating a gradation curve for gradation processing of a medical image represented by a digital signal representation that overcomes the prior art inconveniences.

[0037] More particularly it is an object of the present invention to provide such a method that is applicable to images of different types (such as different examination types) and that renders substantially constant image quality of a repro-

duced or displayed radiographic image without requiring input on the type of image.

[0038] It is a still further object of the present invention to create a gradation curve defined over a relevant signal range without requiring knowledge of the position of the collimation borders.

[0039] Further objects will become apparent from the description given below.

5

SUMMARY OF THE INVENTION

[0040] The above mentioned objects are realised by an image processing method having the features defined in claim 1.

[0041] The method of the present invention is advantageous over the prior art because the shape and signal range of the gradation processing curve are deduced from the signal representation of the image and consequentially the conversion curve is automatically adapted to the specific type of image. No additional information on the type of image is required.

[0042] Moreover, the processed image has a constant contrast and constant density value in a diagnostically relevant area. In this way constant image quality in diagnostically relevant areas is obtained without requiring input of information on the type of image (e.g. examination type) that is processed.

[0043] Consequently all user intervention providing such input of information on the type of image to be processed (which intervention can be manually or by querying a hospital information system or a radiology information system) is avoided. The procedure becomes less complex and less user interaction is required.

[0044] It is no longer necessary to store gradation curves of different shapes adapted to different examination types in advance. The method thus reduces the required storage capacity.

[0045] Moreover, no information on the collimation area is required.

[0046] The gradation curve has a fixed ordinate value and a fixed slope in an anchor point. The anchor point is defined by the fixed ordinate value and by an abscissa value which is deduced from the digital signal representation of the image.

[0047] Preferably the gradation curve is a composite curve consisting of at least three contiguous segments comprising a foot segment spanning a range $[t_0, t_f]$, a body segment spanning a range $[t_f, t_s]$ and shoulder segment spanning a range $[t_s, t_1]$, these segments in combination form a curve that is continuous and that has a continuous derivative.

[0048] The conversion curve is preferably such that an increase of the signal range $[t_0, t_1]$ causes the average slope of the foot segment or the average slope of the shoulder segment, or both average slopes to decrease, without altering the slope of the body segment.

[0049] In one embodiment the signal representation is obtained by the steps of irradiating an object by means of a dose of radiation, detecting by means of a radiation detector the radiation attenuated by said object, and converting detected radiation into a digital image. The pixel values of the digital image and the abscissa values of the conversion curve are preferably expressed as a quantity that is related to the dose in such a way that the noise level in the image is independent of the pixel value. Preferably an abscissa value represents the square root of the dose acquired by said detector in the corresponding pixel. The ordinate axis preferably represents a perceptual linear quantity.

[0050] The embodiments of the methods of the present invention are generally implemented in the form of a computer program product adapted to carry out the method steps of the present invention when run on a computer. The computer program product is commonly stored in a computer readable carrier medium such as a CD-ROM. Alternatively the computer program product takes the form of an electric signal and can be communicated to a user through electronic communication.

[0051] Specific features for preferred embodiments of the invention are set out in the dependent claims.

[0052] Further embodiments of the invention will be described below with reference to the following drawings.

[0053] The particulars concerning the gradation processing method according to the present invention are set out in paragraph 10 of the detailed description.

[0054] The gradation processing method of the present invention can be applied to any kind of image signal that is to be applied to an output recorder or a display device, irrespective of any processing steps that precede the gradation processing.

[0055] However, the gradation processing method of the present invention has been specifically designed to be used in the context of reproducing or displaying a radiographic image that has been subjected to at least some of a series of the described processing steps 1-9. Moreover, some specific embodiments of the gradation processing method of the present invention make use of elements that have been described in paragraphs 1-9.

[0056] It will however be clear that the gradation processing according to the present invention can be applied independent of described steps 1-9 and that it is not limited to an embodiment incorporating steps 1-9.

BRIEF DESCRIPTION OF THE DRAWINGS

[0057]

Fig. 1 shows an apparatus for acquisition of a digital signal representation of a medical image, for processing the digital representation and for generating an enhanced visible image,
 Fig. 2 is a block scheme illustrating the image chain,
 Fig. 3 is a conversion function applied for reducing excess contrast,
 5 Fig. 4 is a conversion function additionally applied for boosting subtle contrast,
 Fig. 5 is a composite conversion function,
 Fig. 6 shows the composite conversion function derivative which has a local minimum,
 Fig. 7 shows a non-compliant case of a composite conversion function (solid line) which is not monotonic, along with its derivative (dotted line),
 10 Fig. 8 shows the attenuation coefficient as a function of local contrast to noise ratio at successive scales,
 Fig. 9 shows an embodiment of a gradation curve composed of three contiguous segments,
 Fig. 10 illustrates the evolution of the gradation curve with varying subrange (first embodiment),
 Fig. 11 illustrates the evolution of the gradation curve with varying subrange (second embodiment),
 Fig. 12 illustrates a gradation curve with linear extensions (third embodiment).
 15 Fig. 13 depicts a neighbourhood for scoring a central pixel as part of a selection criterion used in generating a binary mask image of relevant pixels.

DETAILED DESCRIPTION OF THE INVENTION

20 Description of an image acquisition system

[0058] X-rays emitted by a source of radiation (2) are transmitted by a patient (not shown) and recorded on a temporary storage medium, more particularly a photostimulable phosphor screen (3). In an identification station (4) patient identification data are written into a memory device, e.g. an EEPROM provided on a cassette carrying the photostimulable
 25 phosphor screen.

[0059] The exposed photostimulable phosphor screen is then fed into a read out apparatus (1) where a digital signal representation of the stored radiation image is generated.

[0060] For this purpose the exposed screen is scanned by means of radiation having (a) wavelength(s) within the stimulation wavelength range of the photostimulable phosphor.

30 Image-wise modulated light is emitted by the phosphor upon stimulation. This light is detected and converted by an optoelectronic converter and subsequent A-to-D converter into a digital signal representation of the radiation image.

[0061] The digital signal representation is applied to an image-processing module (7), which can be incorporated in the read out device or provided as a separate unit. In the image-processing module the digital signal representation is subjected to different kinds of processing, among which are multi-resolution contrast enhancement, noise reduction and
 35 gradation processing.

[0062] Finally the processed digital image representation is applied to an output apparatus such as a hard copy recording device (6) or a display monitor (5) where a visible image is generated. The visible image can be used by the radiologist for making a diagnosis.

40 Image chain

[0063] By means of the terms 'image chain' is meant the sequence of image operations and image processing control mechanisms that are applied either separately or in combination to the signal representation of the image for transforming the signal generated by the read out device into a processed digital signal representation that can be applied to the
 45 output device.

[0064] A block diagram illustrating the entire image chain is illustrated in figure 2.

[0065] The image chain comprises the steps enumerated below. Each of the steps will be described extensively in the following.

[0066] In a preliminary step the digital signal representation of an image is subjected to a conversion according to a square root function, in order to make the pixel values proportional to the square root of the radiation dose recorded on the photostimulable phosphor screen. The resulting image is called a raw digital image.

[0067] One of the main sources of noise in the image is quantum mottle, which has a Poisson distribution. The square root conversion ensures that the noise statistics is transformed into a Gaussian distribution, with a standard deviation that is independent of dose. The latter pre-processing of the digital image is not essential, but it greatly simplifies the mathematics of the subsequent processing stages, because the noise can then be assumed roughly uniform across the
 55 raw image.

[0068] In an alternative embodiment, the square root conversion is carried out in the read out apparatus by means of an amplifier with square root characteristic. A raw digital image is generated by applying A-to-D conversion to the resulting

signal.

[0069] With both embodiments, the raw digital image is used for further processing.

[0070] In a first processing step the raw digital image is decomposed into at least two detail images at successive scales and a residual image (further referred to as multiscale representation), according to a multi-resolution transform.

[0071] From the multiscale representation and/or the raw digital image a number of values such as noise level, gain factor, local contrast to noise ratio (CNR) estimations are derived. These values will be used in the following steps.

[0072] In the next step the multi-scale representation is subjected to a normalisation procedure to cancel out disturbing fluctuations which are due to dose variations, different exposure parameters, different patient latitude etc.

[0073] This is followed by a reduction of excess contrast in the image. This step comprises a limitation of the signal range by applying a conversion function that consists of a linear and an exponential part.

[0074] The reproduction of subtle details is enhanced by means of an amplifying component that is superposed on the function for limiting the signal range.

[0075] In the following processing step the small-scale edges and textures are rendered by controlling the contrast enhancement of details as a function of the scale in the multi-scale representation.

[0076] Next the image is subjected to a tissue-specific contrast enhancement. This enhancement step makes use of a segmentation map derived from the raw image.

[0077] In the subsequent step the pixels of the multi-scale representation are locally attenuated or amplified depending upon local contrast-to-noise ratio, which quantity discriminates between homogeneous and non-homogeneous image regions.

[0078] Next the processed multi-scale representation is subjected to a reconstruction step by applying the inverse of the decomposition transform to the modified detail images.

[0079] Finally the reconstructed image is subjected to gradation processing and the pixel values are converted into driving values for the hard- or softcopy reproducing device.

[0080] The processing applied to the signal representation of the radiation image comprises a multi-resolution contrast enhancement. The image is first decomposed into a weighted sum of basis image components at several scales by applying a decomposition transform. The components of the multi-resolution representation are referred to as detail images. The pixel values of the multi-resolution representation correspond with the contrast of elementary image components, relative to their close neighbourhood.

This multi-resolution decomposition step is followed by an image enhancement step wherein the pixel values of the multi-resolution representation are amplified or weakened in order to obtain the envisaged contrast enhancement.

In the next step the modified components are re-combined into a grey value image by applying the inverse of the decomposition transform.

[0081] The multi-resolution decomposition can be performed before the normalisation step as set out in figure 2. Alternatively it can be performed simultaneously with or after normalisation.

[0082] The successive operations applied to the layers of the normalised multiscale representation can be considered as a sequence of concatenated operations, i.e. the input of one operation is the output of the previous operation.

[0083] The contrast enhancing steps shown in figure 2 can be performed in combination. Alternatively individual contrast enhancing steps can be left out (this will however have a consequence on the overall image quality).

1. Multi-resolution transform

[0084] The raw digital image is subjected to a multi-resolution decomposition. The image is decomposed into at least two detail images representing detail at several successive scales.

[0085] This technique has been described extensively in EP 527 525.

[0086] The pixels of the detail images represent the amount of variation of pixel values of the original image at the scale of the detail image, whereby scale refers to spatial extent of these variations.

A residual image can also be generated which is an approximation of the original image with omission of all variations comprised in the detail images.

The detail images at subsequent scales (or resolution levels) are called multi-scale layers, or simply layers.

[0087] In one example the detail images at successively coarser resolution levels (scales) are obtained as the result of each of k iterations of the following steps:

- a) computing an approximation image at a next coarser level by applying a low pass filter to the approximation image corresponding to the current iteration, and subsampling the result in proportion to the reduction in spatial frequency bandwidth, using however the original image as input to said low pass filter in the course of the first iteration;
- b) computing a detail image as the pixelwise difference between the approximation image corresponding to the current iteration and the approximation image at a next coarser resolution level computed according the method sub (a), both images being brought into register by proper interpolation of the latter image; wherein the residual

image is equal to the approximation image produced by the last iteration.

[0088] A reconstructed image can be computed by applying the inverse transform. In the described embodiment a reconstructed image can be computed by iterating k times the following procedure starting from the coarsest detail image and the residual image:

computing the approximation image at the current resolution level by pixelwise adding the detail image at the same resolution level to the approximation image at the coarser resolution level corresponding to the previous iteration, both images being brought into register by proper interpolation of the latter image, using however the residual image instead of said coarser approximation image in the course of the first iteration.

[0089] The residual image will be a low-resolution image or in the extreme case, an image comprising only one single pixel, depending on the number of iterations in the decomposition.

[0090] The latter combination of forward and inverse multiresolution transform is commonly known as the Burt pyramid transform.

[0091] In an alternative embodiment the image is decomposed into a weighted sum of predetermined basic detail images at multiple resolution levels and occasionally a residual basic image by applying a transform to the image, the transform yielding a set of detail coefficients each expressing the relative contribution to the original image of one of a set of basis functions representing these basic detail images and occasionally a residual coefficient representing the relative contribution to the original image of a basis function representing the basic residual image.

[0092] The basis functions are continuous and non-periodic and have zero mean value except for the basis function that represents the basic residual image. An example of such basis functions are wavelets.

[0093] The transform is such that there exists an inverse transform which returns the original image or a close approximation thereof when being applied to the transform coefficients.

[0094] The image can be reconstructed by applying the inverse transform to the detail coefficients and the residual coefficient if generated.

2. Estimating the noise level.

[0095] In one embodiment the noise level in the image is estimated on the basis of a single layer of the multiscale representation of the raw digital image at a predetermined scale. Scale zero is preferred because the relative contribution of the noise in that layer is greater than in the larger scale layers, and hence the estimation of the noise level is less influenced by the presence of image details such as edges, spots and textures.

[0096] In a first step of estimating the noise level an image is computed that represents the local standard deviation at the predefined scale, i.e. at the finest scale.

[0097] The image of local standard deviation at a predefined scale is derived from the corresponding layer of the multiscale representation. The pixel values of the specified layer represent the deviation of the local average grey value at that scale relative to its corresponding value at the next larger scale. In each pixel of the specified layer a square window of N pixel values a_i , centred around the current pixel is taken, and the local standard deviation sdev at current pixel position is computed by taking the square root of the window average of the squared pixel values:

$$sdev = \sqrt{\frac{\sum_{i=1}^N (a_i)^2}{N}}$$

[0098] From the resulting image the histogram of local standard deviation is derived.

[0099] The histogram of an image is an array consisting of a predefined number of bins. Each bin is associated with a specific pixel value interval or single pixel value, in such a way that the entire pixel value range is covered by all subsequent bins. After computation of the histogram each bin represents the absolute or relative number of pixels in the image that have a pixel value within the interval associated with the bin. The histogram is computed as follows. Initially all bins are set to zero count.

Next for each image pixel, it is determined to which predefined interval the pixel value belongs, and the corresponding bin is incremented by one.

[0100] The histogram of local standard deviation is restricted to those pixels that have a grey value within a subrange of the actual grey value range. This means that for each pixel of the image of local standard deviation, the corresponding

histogram bin is incremented only if the corresponding pixel in the grey value image is within specified subrange. If r_{min} and r_{max} are the minimum and maximum grey values respectively of the digital image, then this subrange is defined as: $[r_{min} + margin/(r_{max}-r_{min}), r_{max} - margin/(r_{max}-r_{min})]$. Typically, margin is 3%. By restricting the histogram of local standard deviation to pixels with grey value within the latter subrange, one will avoid cluttering of the histogram by pixels of saturated image regions due to wrong exposure setting or other image artefacts.

[0101] The histogram of local standard deviation has a very much pronounced peak approximately centred at the noise level. The noise level is defined as the centre of this peak. Alternatively, it can be defined as the local standard deviation value that corresponds to the point where the histogram is maximum, or the median value restricted to the dominant peak of the histogram.

3. Automatic calculation of the amplification factor and normalisation of the signal level.

[0102] The pixel values of the digital raw image are proportional to the square root of the radiation dose recorded on the photostimulable phosphor screen. This relation is expressed by the following formula: $r = \sqrt{Ga \cdot x}$ wherein r represents a raw pixel value, x represents a radiation dose value absorbed by the photostimulable phosphor screen and G_a is the global amplification factor of the image acquisition system.

[0103] The average signal level varies from one image to another mainly due to the following factors: radiation dose variations, change of exposure parameters from one exposure to another, attenuation differences related to patient stature, sensitivity change of the read out system.

[0104] With regard to the diagnosis, the original signal level is not that relevant. However, the enumerated fluctuations are disturbing the image processing chain.

[0105] To avoid the disturbing effect of radiation dose fluctuations on the operation of the image processing chain the raw digital image has to be normalised in a multiplicative way. $t = r \cdot G_p$ wherein t is a normalised pixel value and G_p is a normalisation factor.

[0106] A multiplicative correction is equivalent with a change of the read out sensitivity. In case of over or under-exposure, this kind of normalisation provides that the image signal is mapped onto a standard signal range. Nevertheless the end result of this operation is not identical to the result one would get with a correct exposure since by the normalisation operation noise present in the image signal is equally amplified with the signal (whereas increasing the dose would result in an improved signal-to-noise ratio).

[0107] The normalisation factor G_p can be deduced from characteristics of the raw digital image. For computational reasons however, it is preferred to derive the normalisation factor not directly from the raw digital image, but from its multiscale representation instead. Once the normalisation factor is determined, it is preferred to apply it immediately to the pixels of the multiscale representation, since the further processing stages are based on the normalised multiscale representation instead of the normalised raw digital image. For that purpose, all layers of the multiscale representation and the residual image are pixelwise multiplied by the normalisation factor G_p . In an alternative embodiment, a first multiscale decomposition is applied to the raw digital image, the result of which is used only for determining the normalisation factor G_p , next this normalisation is applied to the raw digital image, and a second multiscale decomposition is applied to the normalised raw digital image. The resulting normalised multiscale representation of the raw digital image is identical in both embodiments, and it is used as a basis for further processing.

[0108] In this embodiment the normalisation factor G_p is deduced from the multiscale representation of the raw digital image as will be shown hereafter.

Four criteria have been evaluated and can be applied, each having a number of advantages:

- first criterion: constant signal level
- second criterion: constant noise level
- third criterion: constant contrast
- fourth criterion: preferred embodiment

a) first criterion : constant signal level

[0109] According to this criterion a representative grey value is searched for in the histogram of grey values of pixels of the raw digital image.

This representative grey value is mapped onto a constant reference level T_r .

[0110] The normalisation factor G_l is then equal to T_r/r_1 wherein r_1 is the representative grey value in the histogram.

[0111] This representative grey value is determined as follows:

First a grey value histogram of the raw digital image is calculated restricted to those pixels that have a local contrast-to-noise ratio (CNR) between fixed margins, typically between 2 and 10. The local CNR is represented by a local CNR image, that has the same dimensions as the grey value image from which the histogram is to be computed. The representative grey value is determined as the median of that histogram.

5
[0112] By excluding from this calculation the pixel values that have low contrast-to-noise ratio, pixels in a very homogeneous image area which commonly do not represent relevant information are excluded from having too large an influence on the calculation of the median. Such pixels cover a large area in the image and either have a rather small pixel value (e.g. pixels of collimation borders) or a large pixel value (e.g. pixels in background area).

10 On the other hand, pixels with a very large contrast-to-noise ratio are likewise excluded because they correspond with very strong edges that are commonly found in image regions having a more extreme density.

[0113] This criterion is preferably defined in a way so that the representative grey value looked for roughly corresponds with the density of bone material.

15 **[0114]** In a preferred embodiment, the CNR image is determined at a predefined scale. It is computed by pixelwise dividing the image of local standard deviation at the predefined scale by the estimated noise level. Preferred embodiments of estimating the noise level and computing the image of local standard deviation are described above.

[0115] Preferably the CNR image is determined at a predefined scale that contains a major part of the relevant image information without being cluttered by noise.

Preferably this scale is the fourth scale when scales are counted from fine to coarse.

20 In the smaller scales the relative contribution of noise is larger whereas in the larger scales fine image details tend to disappear.

[0116] In the computation of CNR pixels the nominator is based on the local standard deviation at a predefined scale, typically the fourth scale. However, the denominator representing the noise is estimated at smallest scale for reason of robustness. The noise at larger scales will be smaller due to the repeated averaging processes in the multi-resolution decomposition. The noise at the scale of the nominator can be computed by multiplying the estimated noise at smallest scale by a certain conversion factor, which depends on the weighting factors in the multi-resolution decomposition scheme. The factor can be determined experimentally by estimating the noise according to the above method both at the smallest scale and at the requested scale, based on an image obtained from a uniform exposure, in which all contributions to local standard deviation can be assumed to be due only to noise. The conversion factor is the ratio of the estimated noise at requested scale to the estimated noise at the smallest scale.

30 **[0117]** This first criterion provides that the grey value histogram is placed on a fixed position in the dynamic range.

[0118] This approach provides good results. In case of underexposure however the applied amplification is rather large so that noise is emphasised too extensively.

35 b) second criterion: constant noise level

[0119] In a second embodiment another criterion is applied.

40 According to this second criterion the aim is to bring the noise level to a constant target value in accordance with the formula $G_n = T_n / \sigma_{0n}$ wherein G_n is a normalisation factor, T_n represents the target noise level and σ_{0n} is the estimated noise level.

[0120] The resulting normalisation factor is applied to all pixel values.

The noise level is preferably estimated on the basis of the finest scale of the multi-resolution representation of the image, as described above.

This second criterion results in a uniform impression of noise in all images.

45 However, if a different read out sensitivity is chosen, this has an influence on the contrast. Setting sensitivity low (e.g. sensitivity class 100) may result in a contrast which is too explicit, while setting the sensitivity class high (e.g. sensitivity class 400) may result in a contrast which is too weak.

50 c) Third criterion: constant contrast

[0121] In a third embodiment a still different criterion is applied. According to this criterion the aim is to bring the contrast of the most relevant area in the image to a constant level in accordance with the formula $G_c = T_c / \sigma_c$ wherein G_c is a normalisation factor, T_c is the envisaged contrast level and σ_c is the original contrast.

55 **[0122]** This intrinsic image parameter is somewhat arbitrary because contrast highly varies in the image. The average contrast is not representative because the influence of homogeneous regions (having very low contrast) and of strong border pixels (having large contrast) would be dominating.

[0123] The original contrast is determined by computing the histogram of local standard deviation at a predefined scale that is sufficiently large to avoid predominance of noise, preferably at the fourth scale when scales are counted

from fine to coarse. The original contrast σ_c is defined as the median value of the local standard deviations in the histogram. The histogram of local standard deviation is computed as described above.

[0124] The influence of large homogeneous areas like collimation borders on the original contrast measure is substantially reduced by excluding from the histogram all those pixels of which the local standard deviation is inferior to a certain threshold. The threshold is specified proportional to the noise level. Preferably, the threshold is twice the noise level.

[0125] The noise itself is estimated at the smallest multi-resolution scale, as described above.

[0126] The noise at larger scales will be smaller due to the repeated averaging processes in the multi-resolution decomposition. The noise at the predefined scale at which the original contrast is computed by multiplying the estimated noise at smallest scale by a certain conversion factor, which depends on the weighting factors in the multi-resolution decomposition scheme. The factor can be determined experimentally by estimating the noise according to the above method both at the smallest scale and at the requested scale, based on an image obtained from a uniform exposure, in which all contributions to local standard deviation can be assumed to be due only to noise. The conversion factor is the ratio of the estimated noise at requested scale to the estimated noise at the smallest scale.

[0127] In this embodiment the aim is to have the same amount of contrast in all images. This results in a smoothed reproduction in case of images initially having high contrast, such as thorax images. This effect is only desirable to a limited extent since a complete compensation is experienced as being not natural.

d) Fourth criterion

[0128] The inventors have found that the inconveniences that are enumerated at the end of the description of each of the first to the third embodiment are solved to a large extent if the normalisation factor G_p is determined by combining the three criteria:

$$G_p = G_l^{p_l} \cdot G_n^{p_n} \cdot G_c^{p_c} ,$$

in which the exponents p_l , p_n , p_c , each having a value in the range [0,1] specify the relative contribution of each normalisation factor. This criterion is equivalent to one of the three mentioned above if one of the exponents is one, and the others are zero.

In our preferred embodiment p_l is 0.5, p_n is 0.25 and p_c is 0.25.

4. Reducing excess contrast

[0129] The above normalisation may render an image which has not yet sufficient contrast.

[0130] The signal range defined as the difference between maximal and minimal pixel value in the image fluctuates in between images. The fluctuation is due to the applied kV, the filtering, the size of the patient, and to some extent also to the applied dose and the read out sensitivity.

[0131] A conventional technique consists of adapting the actual signal range to the range reproducible by the medium used for generating a visual image (film or display unit). To achieve this goal commonly a linear and/or non-linear re-scaling of pixel values is applied. The linear re-scaling is commonly referred to as window-level operation while the non-linear mapping is referred to as gradation processing.

In the current commercially available apparatus for reproducing digital medical images a combination of both techniques is applied. This approach is not optimal since the re-scaling has an influence on the image contrast and hence the image contrast may fluctuate between images.

[0132] According to this embodiment a non-linear conversion function is applied to pixels of all layers of the normalised multiscale representation.

In a particular embodiment the conversion function consists of an exponential component combined with a linear term, defined as follows:

$$q(x) = \frac{dd_0}{b^2} \cdot \left(1 - e^{-b \cdot x} \right) + \left(1 - \frac{dd_0}{b} \right) \cdot x$$

wherein

$$b = \frac{dd_0}{1 - d_1}, \text{ and } x \geq 0$$

5 [0133] This conversion function has a fixed slope equal to 1 in the origin and evolves exponentially towards a linear behaviour, with asymptotic slope d_1 . Abscissa and ordinate values are expressed as normalized units in the range [0, 1]. Small input values are left (substantially) unmodified while large input values are attenuated to an extent determined by the slope d_1 .

10 The smaller d_1 , the more the very high contrast transitions within the image will be attenuated. The final slope d_1 must be in the range [0, 1], with most preferable value 0.5.

The parameter dd_0 determines how fast the slope of the function decreases towards its final value d_1 . It is equal to the second derivative of this function in the origin. Its preferred value is in the range [0, 30], most preferably it should be 5. If dd_0 is 0, then the function is linear with unity slope, and no effect takes place.

15 In order to cope also with negative values $x < 0$, the conversion function is extended in the negative domain such that $q(x) = -q(-x)$, i.e. $q(x)$ must be odd.

The positive part of the function is plotted in figure 3.

[0134] Other implementations of the conversion function for reducing excess contrast are possible. As a basic requirement the amplification ratio $q(x)/x$ should be decreasing in the upper pixel value subrange.

20 [0135] The conversion function may be equally applied to all layers, or only to a subset, in that case preferably to the larger scale layers.

[0136] By applying this approach the contrast is upheld in general. Only at very strong transitions in the image that have a large contribution to the dynamic range, the contrast is changed. In these locations the pixels of the normalised multiscale representation are attenuated so that the signal range is decreased. This approach is advantageous in that
25 images with a dynamic range that is too large can be affected with a minimal perturbation of the overall impression of contrast.

5. Enhancing details having subtle contrast.

30 [0137] By the exponential conversion described higher only image components having large contrast are influenced so that the signal range is kept within limits.

[0138] It is then still an object of this invention to enhance the reproduction of subtle details, which are considered to be most relevant.

35 [0139] To achieve this goal, the above conversion function for reducing excess contrast is modulated by a function for subtle contrast enhancement.

[0140] In a particular embodiment the function for subtle contrast enhancement is defined as follows:

40

$$z(x) = 1 + c \cdot \frac{\tanh(a \cdot x)}{1 + \frac{a \cdot c}{b - 1} \cdot x}$$

45 wherein the parameter a controls the input value x_p at which the amplification is maximal, the parameter b controls the amount of contrast enhancement and the parameter c controls the initial slope of the amplification function, i.e. the slope at input value zero.

[0141] At zero input this function has a value one (which means no enhancement), next it increases sharply to a maximum, and from there it falls off again to an asymptotic value of one. Hence its enhancement effect is concentrated within a narrow region, which is controlled by the parameter a . The latter is adjusted in order to apply most enhancement to the details which have contrast in a subrange which is considered to be most relevant.

50 [0142] The function for subtle contrast enhancement is combined with the conversion function for reducing excess contrast. The resulting composite function is defined by:

55

$$y(x) = q(x) \cdot z(x)$$

[0143] As a consequence of applying this modulation, pixel values of the normalised multiscale representation in the neighbourhood of the modulation peak corresponding with subtle contrast details are amplified, while the input ranges of very small pixel values corresponding mostly with noise, and the larger input values corresponding to well visible image features are not significantly altered. The very large input values that represent excessive contrast, are reduced

by the first factor in the composite function.

[0144] The parameter a is preferably chosen so that the modulation peak corresponds with a pixel value of the normalised multiscale representation that can be qualified as representing most relevant 'subtle contrast'. The appropriate value for the parameter a depends on the many scaling factors applied throughout the imaging chain and the multi-resolution decomposition. In practice, the range of subtle contrast corresponds to 0.7 to 3.0 times the noise level.

[0145] In a particular embodiment the point of maximal contrast boosting controlled by the parameter a is made proportional to the noise level.

This is advantageous in that it is avoided that details having very low contrast would be emphasised too much. This might occur in homogeneous areas where the normalised multiscale pixels in most cases represent noise.

[0146] In a particular embodiment the maximum amplification determined by the parameter b is between 1 and 5, most preferably it is 2.

[0147] The preferred value of c is such that the relative initial slope of the function is 3. The relative initial slope is the slope of $z(x)$ in $x=0$, relative to the average slope of the increasing section of the function, which is equal to $z(x_p)/x_p$, wherein x_p is the abscissa of maximum amplification.

[0148] Figure 4 shows the function $z(x)$ for $a = 56.3$, $b = 2.35$, $c = 10.7$, which corresponds to a peak amplification of 2 at $x_p = 0.01$. The initial slope is three times the average slope of $2/0.01$.

[0149] In this way it is possible to render visible low-contrast image details with enhanced contrast. Low-contrast image details are not restricted to specific sizes. They can be small scale like trabecular bone texture or septal lines, medium scale such as blood vessels, or large scale like extended nodules or soft tissue structure. If the visibility of such image details is poor because of low contrast, the above method will render those subtle details by enhancing their contrast.

[0150] Examination types for which subtle contrast is of major importance are commonly high dose examinations. They are performed with low read-out sensitivity and hence also have a better signal-to-noise ratio. In an alternative embodiment the maximum amplification determined by the parameter b is made dependent on the signal-to-noise ratio. The higher the SNR, the more b is increased.

An exception to this principle is found in paediatric applications where the dose is kept low in order to protect the young patient although subtle detail is important.

[0151] In still another embodiment, the parameter b is made dependent on the scale, i.e. a series of values of b_s is predefined, one for each scale s .

[0152] In still another embodiment, the parameter b is made dependent on the underlying tissue type, as will be described further on.

[0153] In this particular embodiment the conversion function $y(x)$ is constructed by multiplicative composition $y(x)=g(x) \cdot z(x)$, as depicted in figure 5. The exact shape of the function and the way it is constructed is not critical. Many alternative embodiments are applicable, as long as the conversion function complies with the following constraints:

1) It has to be monotonically increasing, i.e. its slope dy/dx is positive across the entire domain.

2) It has to be odd, i.e. $y(-x)=-y(x)$. This requirement ensures that enhancement is equally applied irrespective of contrast polarity.

3) For large argument values x the amplification ratio $y(x)/x$ has to be decreasing. This ensures that contrast is reduced at very strong transitions in the image that have a large contribution to the dynamic range.

4) The amplification ratio $y(x)/x$ has to have a local maximum in order to provide maximum enhancement within an intermediate subrange of argument values which is considered most relevant. This ensures that the most relevant image details like trabecular bone texture, septal lines, blood vessels, nodules, and soft tissue structure are appropriately rendered.

[0154] It is important to verify that the requirement 1) of monotonicity is not violated as a consequence of providing a local amplification ratio maximum. For, the slope of the composite curve will decrease due to the decreasing amplification beyond its local maximum. The slope may evolve to a local minimum, and then gradually increase to a final value. This is illustrated in figure 6. The steeper the amplification peak, the closer the slope minimum approaches zero. This is allowed to the extent that the slope does not become negative. The latter non-compliant case is depicted in figure 7, which shows a non-monotonic curve.

[0155] The monotonicity can be verified experimentally using numerical software tools (e.g. Mathcad, MathSoft Inc.) In our preferred embodiments described above this will be met if the parameter settings of both the conversion function for reducing excess contrast and the function for enhancing subtle contrast are set in accordance with the listed recommendations.

6. Contrast enhancement in high frequency bands

[0156] The image becomes sharper when more weight is put on the images at the finest scales of the normalised multiscale representation.

[0157] In a first embodiment sharpening is realised by pixelwise multiplying the layers of the normalised multiscale representation with a coefficient that depends upon the scale.

The coefficient is greater than one at the finest scale (scale 0), and it gradually decreases to a value of one at the medium scales, and it further remains one at the larger scales.

[0158] In a second embodiment, the image is sharpened by making the parameter b that determines the contrast enhancement of subtle details dependent on the scale. This is realised according to the present invention by giving the parameter b a maximum value at scale 0, and by decreasing the value of this parameter b according to a geometric series at medium scales and then further keeping the parameter constant at the larger scales.

[0159] In comparison with the first embodiment of sharpening, the approach of this second embodiment provides that the amplification of small-scale detail is only exerted in points having subtle contrast. In this way unnecessary boosting of noise and sharp (strong) borders can be avoided.

7. Tissue-specific contrast adjustment

[0160] In most cases, it is preferred to have additional fine-scale contrast in the bone regions, e.g. to enhance the trabecular structure, or to better visualise potential fractures. To this end additional contrast adjustment is provided based on a segmentation map. The segmentation map is an image in which the pixels are labeled in accordance with the apparent underlying tissue type. In a preferred embodiment, different labels are assigned to pixels belonging to either bone, soft tissue, and background regions.

[0161] Methods for carrying out segmentation are described in literature, e.g. "Segmentation of Bone and Soft Tissue Regions in Digital Radiographic Images of Extremities", S.K. Pakin, R.S. Gaboriski, L.L. Barski, D.H. Foos, K.J. Parker, SPIE Proc. vol 4322, pp. 1296-1302, 2001.

[0162] Tissue-specific adjustment is carried out by pixelwise multiplying the layers of the normalised multiscale representation by a coefficient $a_{s,u}$ which is obtained from a predefined tissue coefficient table, in which s is the scale of the current layer and u is the tissue label of the corresponding pixel in the segmentation map. Proper subsampling or interpolation is needed if the segmentation map and the current layer have different dimensions.

[0163] The preferred coefficients of the tissue coefficient table depend on the set of distinct labels provided by the segmentation map, and may depend on dedicated requirements of specific examinations. However in the case of general radiology the following default coefficient values are recommended.

scale	bone	soft tissue	background
0	1.5	1	0.7
1	1.5	1	0.7
2	1.3	1.15	0.7
3	1.15	1.3	0.85
4	1	1.3	1
5	1	1.15	1
6	1	1	1

[0164] The settings for bone ensure that the trabecular structure and potential fractures are better visualised. The soft tissue coefficients are chosen to enhance the contrast of lesions and normal anatomy, and the background coefficients are chosen to provide less noise.

[0165] In an alternative embodiment, the tissue coefficients as specified in the above table are not multiplicatively applied to the pixels of the multiscale representation, but are used instead to amplify or attenuate the parameter b that specifies the amount of subtle contrast enhancement, as described above. This is preferably done in each pixel of all layers of the normalised multiscale representation.

8. Local CNR-based contrast adjustment

[0166] The noise reduction method disclosed in prior art document EP 574 969 is based on a selective attenuation of

pixels of the smaller scales of the multiscale representation (more particularly of the three smaller scales).

In each of these images the local variance is calculated around each pixel. Next the local variance is compared with the noise variance. If the local variance is significantly larger than the noise variance, it is assumed that the captured pixel comprises relevant image information and no attenuation is applied.

5 **[0167]** On the other hand, if the local variance approximates the noise variance, the image area is considered to be homogeneous and the pixel of the multiscale representation is attenuated in order to locally decrease the contrast.

In this prior art method the attenuation coefficients are determined for a multi-resolution scale independent of the layers at other scales, taking as a reference the noise level at the current scale. This approach has the following drawback.

10 In one and the same pixel the attenuation coefficients of successive scales can largely differ because the correlation between pixels at successive scales is limited and because the calculation of the attenuation is a nonlinear operation. This fact introduces additional noise having small magnitude but a rather artificial pattern.

[0168] To overcome this drawback an alternative approach has been developed.

15 According to this concept, the local attenuation in each layer of the normalised multiscale representation to which noise reduction is applied is derived from a single base CNR image that represents local contrast-to-noise ratio (CNR) at a predefined scale.

The base CNR image is determined as follows. First a local CNR image at a predefined scale is computed as described above. The predefined scale is chosen to be the smallest scale at which the contribution of relevant information is significant.

20 Practice has learnt that the fourth scale is preferred. Next, the resulting image is smoothed to further eliminate the effect of highfrequency noise. This is done by applying a low-pass filter, yielding a base CNR image. Preferably, the low-pass filter is chosen to reduce the spatial bandwidth by a factor of two.

[0169] Each pixel of all layers of the normalised multiscale representation that participate in the local CNR-based contrast adjustment is multiplied by an attenuation coefficient a that is computed in each pixel as follows:

25

$$a = \left(\frac{cnr_0}{cnrc} \right)^q \quad \text{if } cnr < cnr_0$$

30

$$a = \left(\frac{cnr}{cnrc} \right)^q \quad \text{if } cnr_0 \leq cnr \leq cnr_1$$

35

$$a = \left(\frac{cnr_1}{cnrc} \right)^q \quad \text{if } cnr > cnr_1$$

40

wherein a is an attenuation coefficient at a given point, cnr is the local contrast-to-noise ratio at the corresponding pixel of the base CNR image, $cnrc$ is a predefined critical contrast-to-noise ratio, and q determines the amount of contrast adjustment. If the dimensions of the base CNR image differ from the dimensions of the current layer to which attenuation is applied, then the base CNR is appropriately interpolated.

45 The plot in figure 8 shows the attenuation coefficient a as a function of local CNR at successive scales.

The critical contrast-to-noise ratio parameter $cnrc$ is the contrast-to-noise ratio for which no attenuation is applied ($a=1$). If $cnr < cnrc$ then the contrast is attenuated by an amount which is determined by the exponent q .

If cnr is greater than the critical value $cnrc$, then a becomes greater than 1 so that local contrast is amplified.

In this way it is prevented that the global contrast perception in the image is significantly affected by the noise limitation.

50 In homogeneous areas contrast will be decreased but in texture areas the contrast is somewhat increased. In a preferred embodiment, the critical contrast-to-noise ratio parameter $cnrc$ is in the range [5,10], preferably it is 7. The preferred value will differ however depending on scaling factors and weights used throughout the method of multiscale decomposition, of determining local contrast, and of estimating the noise. It is preferably verified experimentally.

[0170] The parameters cnr_0 and cnr_1 specify the bounds of the range of CNR values within which the attenuation a is a function of CNR. Beyond these bounds, the attenuation attains a fixed minimum or maximum value respectively. This clipping avoids excessive attenuation or enhancement of the local contrast.

55 The CNR bounds are computed by:

$$cnr_0 = cnrc \cdot 10^{-0.1 \cdot \frac{wtr}{1+npc}}$$

5

$$cnr_1 = cnrc \cdot 10^{0.1 \cdot \frac{npc \cdot wtr}{1+npc}}$$

10

in which wtr is a parameter that specifies the dynamic range of CNR values expressed in dB within which the attenuation a is a function of CNR, and npc specifies the amount of compensation for loss of sharpness, which must be in the range $[0, 1]$.

[0171] The exponent q is computed by:

15

$$q = \left(1 - \frac{s}{Ns}\right) \cdot (1 + npc) \cdot \frac{att}{wtr} \quad \text{if } s < Ns$$

20

$$q = 0 \quad \text{if } s \geq Ns$$

25 where s is the scale of the current layer, and Ns the number of layers involved in the local CNR-based contrast adjustment process. The scale s is defined to increase from small scale to large scale, starting from zero. Because the importance of noise decreases with increasing scale, the amount of noise reduction is decreased at larger scales relative to the noise reduction at smaller scales. In all cases, the attenuation coefficient a evolves gradually to 1 as the scale s approaches Ns , which means that from this scale on, the local CNR-based contrast adjustment has no effect anymore. Preferably, Ns is in the range $[2, 5]$, most preferably it is 4.

30

The amount of attenuation is specified by the parameter att , which equals the strongest attenuation at zero scale, expressed in dB, i.e.:

35

$$att = -10 \log a_0,$$

in which a_0 is the attenuation coefficient that will be found in those regions of layer zero where $CNR \leq cnr_0$. Preferably the attenuation att is in the range $[0, 6\text{dB}]$, most preferably it is 2dB.

40

[0172] The parameter npc determines to which amount the global impression of loss of sharpness due to contrast reduction in low CNR regions, is to be compensated by increasing the local contrast in high CNR regions. In the extreme case where npc is zero, there will be no compensation for loss of sharpness, which means that the attenuation coefficient a in the zero scale layer will be in the range $[a_0, a_1 = 1]$. Maximum compensation is achieved by setting npc to one, in which case the maximum enhancement is equal to the inverse of the maximum attenuation. In this case, scale zero attenuation coefficients will be in the range $[a_0, a_1 = 1/a_0]$. The parameter npc is preferably set to 0.4 in order to have partial compensation of sharpness loss. The parameter wtr is preferably set to 3dB. If the parameters are set to the above preferred values, $att = 2\text{dB}$, $wtr = 3\text{dB}$, $cnrc = 7$, $npc = 0.4$, then the derived parameters at scale zero will have the following values:

45

$cnr_0 = 4.274$, $a_0 = 0.631$, $cnr_1 = 8.527$, $a_1 = 1.202$, $q = 0.933$.

50

At scale 1 the derived parameters will be:

$cnr_0 = 4.274$, $a_0 = 0.708$, $cnr_1 = 8.527$, $a_1 = 1.148$, $q = 0.7$.

The functions that express the dependency of the attenuation coefficient a upon local CNR at successive scales are plotted in figure 8.

55

[0173] In a particular embodiment the attenuation coefficients a for a certain scale are provided in the form of an image matrix, referred to as attenuation coefficient-matrix, the latter having dimensions equal to the dimensions of the corresponding layer of the normalised multi-scale representation. The effective attenuation is obtained by pixel-wise multiplication of the attenuation coefficient-matrix with the pixels of the corresponding image of the multi-resolution decomposition.

[0174] With the above method, the image regions in which the average radiation contrast is very small, i.e. in homogeneous regions where noise is most disturbing, the contrast will be lowered. On the other hand it will be raised in those image regions where there is a significant portion of edges or textures.

5 9. Reconstruction

[0175] When the above procedures for contrast enhancement have been performed, the image is reconstructed by applying to the modified detail images the image transform that is the inverse of the multi-resolution decomposition. Details on the reconstruction procedure are described higher in the paragraph relating to image decomposition.

10

10. Gradation processing with three control points

[0176] After image reconstruction the image is not yet ready for reproduction on film or for display on a monitor because the signal range does not yet correspond to the output range of the reproduction system (hard or soft copy).

15 [0177] The conversion of pixel values into output values suitable for reproduction commonly comprises a selection of a sub-range comprising the relevant information followed by a conversion which is in most cases a non-linear conversion. This conversion is referred to as gradation processing.

For optimal reproduction it is of ultimate importance that the selection of the relevant signal range is performed in a consistent way and that the shape of the conversion function applied for gradation processing is determined carefully.

20 This conversion determines to a large extent the quality of the visible image as far as average density and overall contrast is concerned.

[0178] In the state of the art the selection of the sub-range and the selection of the gradation curve depends on the examination type which was entered into the processing system. Moreover, the selection of the relevant sub-range was performed on the basis of the image histogram. Pixels belonging to the collimation borders were not considered.

25 Therefore it was required to detect the collimation borders in advance. Because of the wide diversity of images and the complexity of this problem, a certain percentage of failures is inevitable (around 1%). As a consequence the correct operation of the detection of the relevant signal range is affected. It is an object of the present invention to enable selection of the relevant signal subrange without using any knowledge of the collimation borders.

[0179] According to the present invention a gradation processing operation is developed which is controlled by three characteristic points in the image histogram.

30 A gradation curve is generated which yields a fixed contrast and a fixed density in one specific point, referred to as anchor point.

[0180] In the state of the art the gradation curve abscissa axis is related to the logarithm of radiation dose, and the ordinate axis may be optical density, luminance, driving values of specific display systems, or else perceptually linear units (p-values), as specified by the DICOM 3.14 standard. The main reason why the abscissa axis represents the logarithm of radiation dose originates from the X-ray film technology, in which the sensitivity curve of the screen-film system, the so-called H-D curve, is specified in terms of optical density as a function of logarithm of exposure.

35 A second reason for expressing the abscissae in logarithm of dose is related to the way the curve is manipulated for the purpose of contrast and density adjustment. Shifting the curve along the abscissa axis is equivalent to multiplying the dose by a certain factor. Hence, a simple shift of the curve (so-called level-adjustment) allows to correct for under- of overexposure. Modifying the level is the equivalent of selecting a film-screen combination with a different speed class.

40 [0181] In a preferred embodiment, the input to the image chain is a digital image the pixel values of which are proportional to the square root of radiation dose, as explained above. Square root semantics are preserved throughout the image chain, including multiscale decomposition, a series of contrast manipulation methods applied to the multiscale representation, and finally, an inverse multiscale transform.

45 According to the present invention the result of the image chain with square root of dose semantics is used as the input quantity of gradation processing without conversion into logarithm of dose semantics. Gradation processing is specified to map this pixel quantity onto an ordinate axis that represents perceptually linear units according to a function that is linear with a fixed slope in the central portion of its domain. The combination of imposing square root semantics on the abscissa, applying a gradation curve that is essentially linear, and imposing a perceptually linear semantics on the ordinate axis, e.g. in accordance with the DICOM 3.14 standard, assures that the image noise due to quantum mottle will be perceived uniform in the viewed image across the entire density range.

50 The latter only holds if the nonlinear operations applied to the multiscale representation for the purpose of contrast enhancement are kept small, such that the entire part of the image chain from multiscale decomposition through inverse transform can still be considered a linear operation.

55 In this preferred embodiment it is also assumed that the output image that results from gradation processing is transmitted to a hard- or softcopy device that accepts image data with perceptually linear semantics. This is true with new generation film printing devices and display monitors that are compatible with the DICOM 3.14 standard. It is assumed in the further

description that the output image is expressed in terms of perceptually linear units, called p-values. If the output image is to be sent to a non-standardised device however, an appropriate additional conversion has to be applied to the output image in order to match the specific input semantics of the device, which may be either optical density, luminance or proprietary semantics. How to do this is described in the DICOM 3.14 standard specification.

5 **[0182]** Preferably the gradation curve is composed of three contiguous segments, as depicted in fig. 9, termed foot, body and shoulder segments, respectively. The segments are defined in such a way, that the composite gradation curve is continuous along its entire domain, and also its derivative is continuous.

[0183] The body segment is linear, and it ensures fixed predefined slope g_b across the body subrange w_b , which is intended to coincide with the most relevant subrange of pixel values. The foot segment spanning the foot subrange w_f provides a gradual increase of slope from a predefined initial slope g_0 up to the body slope g_b . The corresponding subrange is considered a transition zone from the lowest pixel values that carry no diagnostically relevant information, up to the most relevant body subrange. The foot segment is characterised by its subrange width w_f and height h_f on the ordinate axis. Its average slope g_f is defined by the ratio h_f/w_f . The initial ordinate value of the foot segment corresponds with the smallest value of the ordinate range y_0 , i.e. the smallest possible value of the output image. In a preferred embodiment, y_0 is zero. The transition point from foot to body is specified by the abscissa t_f . The shoulder segment spanning the subrange w_s provides a gradual decrease from the body slope g_b down to a predefined final slope g_1 . This segment is characterised by its width w_s and a predefined average slope g_s , which defines the ratio h_s/w_s , in which h_s is the shoulder segment height on the ordinate axis. The final ordinate value of the shoulder is made to coincide with the greatest value of the ordinate range y_1 . In a system with 12 bit output, y_1 will be 4095.

20 **[0184]** The body segment has a predefined slope g_b and a predefined anchor point t_a . The anchor point has a predefined output pixel value y_a . This condition ensures that contrast and density remain fixed in the anchor point. The width of the foot, body and shoulder segments is not specified explicitly. Instead, for each individual image three characteristic pixel values are determined, which specify the lower foot bound t_0 , the anchor point t_a and the upper shoulder bound t_1 .

25 The other parameters that determine the shape of the composite gradation curve are predefined, i.e. they do not depend on any characteristic of the individual images. Given the predefined parameters and the parameters t_0 , t_a and t_1 which are determined specifically for each image, a composite gradation curve is determined that spans the cumulative abscissa subrange $w_f+w_b+w_s$ and the corresponding ordinate range $[y_0, y_1]$, in compliance with the above requirements of continuity.

30 **[0185]** One embodiment of the composite gradation curve is defined by:

35
$$y(t) = y_0 + h_f \cdot f\left(\frac{t-t_0}{w_f}\right) \quad \text{if } t \text{ is in the foot subrange } [t_0, t_f[$$

40
$$y(t) = y_0 + h_f + g_b \cdot (t - t_f) \quad \text{if } t \text{ is in the body subrange } [t_f, t_s]$$

45
$$y(t) = y_1 - h_s \cdot s\left(\frac{t_1-t}{w_s}\right) \quad \text{if } t \text{ is in the shoulder subrange }]t_s, t_1]$$

[0186] In this embodiment the function that corresponds with the foot segment is defined by:

50
$$f(x) = x \cdot g_{0f}^{1-x^{pf}}$$

in which:

55
$$g_{0f} = g_0 \cdot \frac{w_f}{h_f}$$

is the relative initial foot slope

$$pf = \frac{1 - gb \cdot \frac{wf}{hf}}{\ln(g_0 f)}$$

[0187] In this embodiment the function that corresponds with the shoulder segment is defined by:

$$s(x) = x \cdot g_{1s}^{1-x^{ps}}$$

in which:

$$g_{1s} = g_1 \cdot \frac{ws}{hs}$$

is the relative final shoulder slope

$$ps = \frac{1 - gb \cdot \frac{ws}{hs}}{\ln(g_{1s})}$$

[0188] The above formulation of the foot and shoulder segments based on concatenated exponentials ensures that:

- $y(t_0) = y_0$, and $y(t_1) = y_1$
- continuity is guaranteed in the transition points $y(t_f)$ and $y(t_s)$
- $y'(t_0) = g_0$ and $y'(t_1) = g_1$
- the slope is continuous in the transition points $y'(t_f)$ and $y'(t_s)$, and it has a constant value gb in between
- the output has a predefined value y_a in the anchor point t_a .

The latter two features ensure that the most relevant subrange of pixel values associated with the body segment has a specified density and contrast.

[0189] The position of the anchor point t_a , the lower foot segment bound t_0 and the upper shoulder segment bound t_1 are made dependent on the image subrange characteristics, as will be described further on.

[0190] Any variation of the lower subrange width $[t_0, t_a]$ as imposed by the image characteristic does not influence the density and contrast of the pixel values greater than t_a . This is important because the required lower subrange width may largely vary due to the presence of radio-opaque material in the image, such as markers or collimation shutters. According to the present invention the variation of lower subrange width $[t_0, t_a]$ only affects the density and contrast of pixel values smaller than the anchor point t_a , and the closer a lower subrange pixel value approaches t_a , the less its contrast and density will depend on the lower subrange width. The rationale behind this mechanism is the observation that contrast should be kept as constant as possible, but if the average slope has to be diminished because of increasing lower subrange width, it is better to give up contrast preferably in the lowermost density range, which carries virtually no relevant information, and keep the contrast intact in the vicinity of the anchor point.

Similar benefits of this method also hold in the upper subrange $[t_a, t_1]$, in which contrast is preferably sacrificed in the uppermost density range as the upper subrange width is increasing, in order to preserve contrast in the subrange portion adjacent to the anchor point t_a , in which subrange there is much more relevant information.

[0191] In a first preferred embodiment, the following parameters are predefined: y_0 , y_a , y_1 , g_0 , g_f , g_b , g_s , g_1 . The other parameters which are needed to generate the above composite gradation curve, i.e. w_f , h_f , w_s , h_s , are derived as follows.

[0192] The width w_f and height h_f of the foot segment are found by solving the set of equations, which specify the heights of the left body part and foot segment, respectively:

$$y_a - y_0 - hf = (t_a - t_0 - wf) \cdot gb$$

5

$$hf = wf \cdot gf$$

yielding:

10

$$wf = \frac{(t_a - t_0) \cdot gb - y_a + y_0}{gb - gf}$$

15

$$hf = wf \cdot gf$$

[0193] Similarly, the width w_s and height h_s of the shoulder segment are found by solving the set of equations, which specify the heights of the right body part and shoulder segment, respectively:

20

$$y_1 - y_a - h_s = (t_1 - t_a - w_s) \cdot gb$$

25

$$h_s = w_s \cdot g_s$$

yielding:

30

$$w_s = \frac{(t_1 - t_a) \cdot gb - y_1 + y_a}{gb - g_s}$$

35

$$h_s = w_s \cdot g_s$$

[0194] The predefined values preferably lie in the following ranges:

40

- y_a : [10,40], default 20 % of output range $[y_0, y_1]$
- g_b : depends on internal scaling factors throughout the imaging system, and on the available output range
- g_0 : [10,30], default 20 % of body slope g_b
- g_f : [25,50], default 40 % of body slope g_b
- g_s : [25,50], default 40 % of body slope g_b
- g_1 : [5,20], default 10 % of body slope g_b

45

In any case the slopes must respect the following inequalities:

50

$$g_0 < g_f < g_b$$

$$g_1 < g_s < g_b$$

55

[0195] The foot and lower body segments evolve as follows with varying lower subrange. If t_0 exceeds a maximum bound t_{0u} , then it is set to this value

$$t0 \leq t0u = ta - \frac{ya - y0}{gb}$$

5
[0196] In this case, the foot segment is collinear with the body segment. See fig. 10.
 If the width of [t0, ta] increases, then a foot segment is emerging in the lower subrange. The foot segment becomes more significant at the expense of the linear part as the lower subrange width further increases. [E.g. in figure 10 when it evolves from w''_f to w'_f]

10 **[0197]** Ultimately, a lower limit for t0 is reached, t0l, defined by:

$$t0 \geq t0l = ta - \frac{ya - y0}{gf}$$

15
[0198] The upper body segment and shoulder evolve in a similar manner. The bounds for t1 are defined by:

$$t1 \geq t1l = ta + \frac{y1 - ya}{gb}$$

$$t1 \leq t1u = ta + \frac{y1 - ya}{gs}$$

20
[0199] In that case the foot extends from toe to ta.
 30 The bounds of t0 and t1 may be further constrained in order to ensure that foot or shoulder cannot entirely vanish, i.e. a minimum foot and shoulder width are specified. Preferably, hf and hs should be enforced to be at least 10% of the output range [y0,y1].

This avoids abrupt changes of contrast in the vicinity of the subrange bounds t0 and t1, respectively.

35 **[0200]** Further constraints may be imposed to the bounds of t0 and t1 in order to enforce a minimum or maximum portion of body segment left or right of the anchor point ta. With this measure one can ensure that there is at least a central portion of the gradation curve that is entirely linear.

40 **[0201]** In a second preferred embodiment, the following parameters are predefined: y0, ya, y1, g0, gb, gs, g1. Furthermore, the foot-to-body transition point is set equal to the anchor point, i.e. tf=ta and correspondingly, yf=ya. The other parameters which are needed to generate the above composite gradation curve, i.e. wf, hf, ws, hs, are derived as follows.

[0202] The foot width and height are defined by:

$$wf = ta - t0$$

$$hf = ya - y0$$

50 **[0203]** The combined segment width of body and shoulder is equal to

$$wbs = t1 - ta$$

55 **[0204]** The widths of the body segment wb and of the shoulder segment ws are found by solving the set of equations, which specify the heights of the body and shoulder segments, respectively:

$$hb = wb \cdot gb$$

$$(y1 - y0) - (hf + hb) = (wbs - wb) \cdot gs$$

yielding:

$$wb = \frac{y1 - y0 - hf - wbs \cdot gs}{gb - gs}$$

$$ws = wbs - wb$$

[0205] The shoulder height is then:

$$hs = ws \cdot gs$$

[0206] The preferable settings of predefined parameters with this second embodiment are the same as with the first embodiment.

[0207] The foot segment evolves as follows with varying lower subrange width [t0, ta]. It has a predefined height hf=y0-y1, hence its average slope will decrease with increasing lower subrange width. The slopes at both subrange bounds g0 and gb are predefined, which ensures a smooth transition. However, the narrower the foot width, the steeper the evolution will be. This is shown in figure 11.

[0208] The evolution of the upper body segment and shoulder is similar to the first embodiment.

[0209] In a third or fourth embodiment, the gradation curve as defined in the first or second embodiment, respectively, is extended by linear segments left from t0 and right from t1, as depicted in figure 12. These marginal segments having slopes g0 and g1 respectively, provide that any valuable pixel values that might fall outside the subrange [t0,t1] due to inaccurate determination of the subrange bounds, are still converted into output pixel values with non-zero contrast. The slopes g0 and g1 are equal to the initial foot slope and final shoulder slope, respectively.

[0210] In state of the art gradation methods, such pixels that fall outside the specified subrange are set to a constant low or high pixel value, whereby all image information beyond this range is definitively lost.

According to the present gradation method, the output image is made available for a display workstation together with its accompanying subrange parameters [y0, y1]. Most state of the art display systems e.g. the ones that are DICOM-compliant are able to understand and use the accompanying subrange bounds. In default mode, the display system selects the indicated subrange [y0, y1] from the received image data, and maps this subrange onto its entire display range. In this mode, the selected subrange is displayed in the most optimal way, and all pixels values beyond the indicated subrange are clipped to either white or black. If one is interested however to see pixel value differences outside the selected subrange, then this is made possible by interactively enlarging or the shifting the selected subrange, so that the pixel values of interest move into the new subrange.

[0211] The predefined position of the default output subrange [y0, y1] that corresponds to the selected input range [t0, t1] is preferably such that it provides some margin for both gradation curve extensions. For example, in case of a 12 bit output image, the default output range is preferably defined as the range [y0=512, y1=3583], so that each margin spans 1/8 of the total output range. The corresponding window width is 75%, and the window centre is 50%.

[0212] In a preferred embodiment, the gradation processing is applied to the result image of multiscale reconstruction which is the last stage in the enhancement methods described above. The latter image will be further called the enhanced image.

[0213] The composite gradation curve is generated as described above based on predefined parameters, and on three parameters t0, t1, and ta, which depend on intrinsic image characteristics. The position of the anchor point ta and the subrange bounds t0 and t1 are determined based on a figure of merit. The latter is derived from the enhanced image, i.e. the image to which gradation is to be applied.

[0214] To this end, a first grey value histogram is computed of the enhanced image, and a second histogram of the

same image, the second histogram being restricted to those pixels that are flagged as relevant in a binary mask image, that has the same dimensions as the enhanced image. The second histogram represents the relative density of grey values in the enhanced image, restricted to the relevant pixel regions.

[0215] The figure of merit fom_j is determined for each grey value j within the range of the enhanced image, as follows:

$$fom_j = \frac{hr_j \cdot hu_j^{-qm}}{\max_j (hr_j \cdot hu_j^{-qm})}$$

in which hu_j and hr_j represent the bin value counts of the unrestricted and restricted histograms, respectively, and in which the maximum is taken across the whole range of grey values.

[0216] Each restricted histogram count is balanced by the corresponding count in the unrestricted histogram, raised to a predefined exponent qm . This exponent is set to a value smaller than one, in order to limit the correction. The rationale behind this correction is the consideration that the relevance of a grey value does not only depend on how many times this value is found in the image, but at the same time, on the rate at which pixels having this value also belong to an image region that is considered relevant, as specified by the binary mask. The greater the ratio of relevant versus irrelevant pixels that have a specific grey value, the greater the figure of merit for that grey value will be.

[0217] The exponent qm is preferably set to a value in the range [0,1], most preferably 0.25. In the extreme case where qm is set to zero, there is no correction. In the other extreme case where qm equals one, the ratio of relevant to irrelevant pixels entirely determines the figure of merit. The figure of merit is in the range [0,1], 1 indicating highest relevance.

[0218] In this embodiment the lower subrange bound $t0$ is determined as the pixel value j for which the figure of merit fom_j exceeds a predefined threshold $Tf0$, starting from the lowest grey value. Similarly, the upper subrange bound $t1$ is determined as the pixel value j for which fom_j exceeds a predefined threshold $Tf1$, starting from the maximum grey value, and proceeding downwards.

[0219] The anchor point ta is determined as follows. Starting from the figure of merit maximum, i.e. the grey value jm for which $fom_j = 1$ the grey value index j is decremented until $fom_j < Tfa$, the latter representing a predefined threshold. The index at threshold crossing specifies the anchor point.

[0220] The thresholds for the sub-range bounds are preferably very small, in order to minimise the risk of excluding relevant grey data from the selected sub-range, e.g. $Tf0 = 0.01$ and $Tf1 = 0.01$. The threshold for the anchor point is preferably in the range [0.1, 0.5], most preferably 0.35.

[0221] The binary mask image that flags the relevant image pixels is needed for determining the restricted grey value histogram. In a first preferred embodiment, the binary mask image is derived from a local CNR image. The dimensions of the mask image has to be adjusted to the dimensions of the local CNR image, which preferably has dimensions that corresponds with the fourth scale of the multiscale representation, as described above. The mask pixels are set to binary TRUE if the corresponding CNR pixel has a local CNR value in the range $[T_{c0}/T_{c1}]$. Hence the pixel values that have low contrast-to-noise ratio, e.g. pixels in a very homogeneous image area which commonly do not represent relevant information are excluded from the binary mask.

[0222] On the other hand, pixels with a very large contrast-to-noise ratio are likewise excluded because they correspond with very strong edges that are commonly found in image regions having a more extreme density. The preferred threshold values are $T_{c0} = 2$, $T_{c1} = 10$.

[0223] In a next step, the mask image is enhanced by applying a cascade of morphological filters to it, corresponding to an opening filter, followed by a closing. The opening filter first eliminates small isolated patches of TRUE pixels in the mask image, and the subsequent closing filter eliminates the holes in the mask.

The disk radius of the structuring elements of the morphological filters is preferably between one and three.

[0224] In a second preferred embodiment also based on the local CNR image, each pixel of the binary mask image is marked as TRUE if its local CNR exceeds a predefined threshold T_{d0} , and an additional score also exceeds a threshold T_{sc} .

The score associated with a pixel is computed by tracing radial paths in eight directions starting from the considered pixel, as depicted in figure 13. The score is initialised to zero. During each path traversal, the score is incremented if the local CNR of the current pixel in the path exceeds a threshold T_{d1} . Each path traversal is terminated at the pixel in which the local CNR exceeds a threshold T_{d2} , or if the radius exceeds a threshold T_{dr} .

[0225] The CNR threshold T_{d0} used as part of the selection criterion for the central pixel is less severe than the threshold T_{c0} used in the first embodiment, e.g. preferably it is 1.0. As a consequence of taking a smaller threshold, more pixels will be taken into account initially. Further rejection is based on the second criterion, which is based on the

number of surrounding pixels within a limited radius that have a CNR that exceed the threshold T_{d1} , which is preferably greater than the threshold for the central pixel, e.g. $T_{d1} = 1.8$.

[0226] The required total count of super-threshold neighbouring pixels is specified by the score threshold T_{sc} , preferably set to 50. With this setting, in a neighbourhood comprising exclusively super-threshold pixels, a path radius of at least 7 will be required in order to yield a successful score. In practice, the supporting neighbourhood is allowed to have 'holes' of sub-threshold pixels, or it may be asymmetric if the central pixel is close to an edge. Therefore, the upper limit for the path radius is specified much larger, preferably T_{dr} is greater than 20, most preferably 30.

[0227] The method in accordance with the present invention aims at flagging only those pixels belonging to coherent regions, in which the local CNR does not vary too much. In that perspective, the additional terminating criterion that stops path traversal if the local CNR exceeds the threshold T_{d2} , avoids extending the flagged region across strong edges. The preferred setting for T_{d2} is 4.5.

Claims

1. Method of creating a gradation curve for gradation processing of an image represented by a digital signal representation to generate a gradation processed image wherein the shape of the gradation curve and signal range for which the gradation curve is defined are deduced from said digital signal representation and wherein said gradation curve has a predefined ordinate value and a predefined slope in an anchor point,
characterized in that the abscissa value t_a of said anchor point is determined as follows:

- determine an unrestricted grey value histogram of said image,
- determine a restricted grey value histogram of said image by restricting said histogram to pixels flagged relevant in a binary mask image with same dimensions as said image,

- calculate a figure of merit fom_j for each grey value j within said image by applying the formula

$$fom_j = \frac{hr_j \cdot hu_j^{-qm}}{\max_j (hr_j \cdot hu_j^{-qm})}$$

wherein hr_j represents the histogram frequency for grey value j in the restricted

grey value histogram and hu_j represents the histogram frequency in grey value j in the unrestricted grey value histogram, qm is a predefined Exponent and the maximum is taken across the range of grey values,

- determine the abscissa value t_a of said anchor point by examining the sequence of figures of merit fom_j for all grey values j downwards, starting from the grey value for which the figure of merit is maximum, and setting t_a equal to the first grey value for which the corresponding *figure of merit is below* a predefined threshold T_{fa} .

2. A method according to claim 1 wherein said gradation curve is a composite curve consisting of at least three contiguous segments comprising a foot segment spanning a range $[t_0, t_f]$, a body segment spanning a range $[t_f, t_s]$ and shoulder segment spanning a range $[t_s, t_1]$, these segments in combination forming a curve that is continuous and that has a continuous derivative, whereby the body segment has a predefined average slope.

3. A method according to claim 2 wherein said body segment is linear.

4. A method according to claim 2 wherein an increase of the signal range $[t_0, t_1]$ is effectuated by

- (a) adjusting the foot width while keeping its height constant or
- (b) adjusting the foot width while keeping its average slope constant or
- (c) adjusting the shoulder width while keeping its height constant or
- (d) adjusting the shoulder width while keeping its average slope constant or
- (e) adjusting both foot and shoulder width by any of the above basic adjustment schemes (a) to (d).

5. A method according to claim 1 wherein the signal representation is obtained by irradiating an object by means of a dose of radiation, detecting by means of a radiation detector the radiation attenuated by said object, and converting detected radiation into a digital signal representation,

and wherein said gradation curve is defined in a coordinate system wherein abscissa values are expressed as a quantity that is related to the dose of radiation in such a way that the noise level in the image is roughly independent of the pixel value, and wherein ordinate values represent a perceptual linear quantity.

- 5 6. A method according to claim 1 wherein an abscissa value represents the square root of the dose acquired by said detector in a corresponding pixel.
7. A method according to claim 1 wherein said anchor point has coordinate values (ta, ya), whereby ta is defined on the basis of a characteristic position on the pixel value axis of a histogram of the image.
- 10 8. A method according to claim 2 wherein t0, t1 are deduced from the signal representation of the image.
9. A method according to claim 2 wherein the lower foot segment bound t0 is mapped onto a value y0 that is predefined.
- 15 10. A method according to claim 9 wherein y0 equals the smallest value that can be visualised by a display or reproduction device or material reproducing said image.
11. A method according to claim 2 wherein said lower foot segment bound is determined by the steps of

- 20 - determine an unrestricted grey value histogram of image,
 - determine a restricted grey value histogram, restricted to pixels flagged relevant in a binary mask image with same dimensions as said image,

- 25 - calculate a figure of merit fom_j for each grey value j within said image by applying the formula

30
$$fom_j = \frac{hr_j \cdot hu_j^{-qm}}{\max_j(hr_j \cdot hu_j^{-qm})}$$
 wherein hr_j represents the histogram frequency for grey value j in the re-

stricted grey value histogram and hu_j represents the histogram frequency in grey value j in the unrestricted grey value histogram, qm is a predefined exponent, and the maximum is taken across the range of grey values,

- 35 - determine the abscissa value t0 by examining the sequence of figures of merit fom_j for all grey values j upwards starting from the minimum grey value, and setting to equal to the first grey value for which the corresponding figure of merit exceeds a predefined threshold Tf0.

- 40 12. A method according to claim 2 wherein the upper shoulder segment bound t1 is mapped onto a value y1 which is predefined.

13. A method according to claim 12 wherein y1 equals the largest value that can be reproduced by a display or reproduction device or material reproducing said

- 45 14. A method according to claim 2 wherein said upper shoulder segment bound is determined by the steps of

- determine an unrestricted grey value histogram of image,
 - determine a restricted grey value histogram, restricted to pixels flagged relevant in a binary mask image with same dimensions as said image,

- 50 - calculate a figure of merit fom_j for each grey value j within said image by applying the formula

55

$$fom_j = \frac{hr_j \cdot hu_j^{-qm}}{\max_j(hr_j \cdot hu_j^{-qm})}$$

wherein hr_j represents the histogram frequency for grey value j in the re-

stricted grey value histogram and hu_j represents the histogram frequency in grey value j in the unrestricted grey value histogram, qm is a predefined exponent, and the maximum is taken across the range of grey values,

- determine the abscissa value $t1$ by examining the sequence of figures of merit fom_j for all grey values j downwards starting from the maximum grey value, and setting $t1$ equal to the first grey value for which the corresponding figure of merit exceeds a predefined threshold $Tf1$.

15. Method of gradation processing a digital signal representation of an image by applying a gradation curve **characterised in that** said gradation curve is obtained by a method of any of the claims 1-14.

16. A computer program product adapted to carry out the method of any of the preceding claims when run on a computer.

17. A computer readable medium comprising computer executable program code adapted to carry out the steps of any of the preceding claims.

Patentansprüche

1. Ein Verfahren zum Erstellen einer Gradationskurve für die Gradationsverarbeitung eines durch eine digitale Signaldarstellung dargestellten Bildes zur Erzeugung eines gradationsverarbeiteten Bildes, **dadurch gekennzeichnet, dass** die Form der Gradationskurve und der Signalbereich, für den die Gradationskurve gelegt wird, aus der digitalen Signaldarstellung abgeleitet werden und die Gradationskurve einen vorgegebenen Ordinatenwert und eine vorgegebene Neigung an einem Stützpunkt aufweist,

dadurch gekennzeichnet, dass der Abszissenwert t_a des Stützpunktes wie folgt ermittelt wird :

- Ermittlung eines unbeschränkten Grauerthistogramms des Bildes,
- Ermittlung eines beschränkten Grauerthistogramms des Bildes durch Beschränkung des Histogramms auf Pixel, die in einem binären Maskenbild mit den gleichen Abmessungen wie das Bild mittels eines Flags als relevant markiert sind,
- Berechnung einer Gütezahl fom_j für jeden Grauwert j im Bild durch Anwendung der Formel :

$$fom_j = \frac{hr_j \cdot hu_j^{-qm}}{\max_j(hr_j \cdot hu_j^{-qm})}$$

in der hr_j die Histogrammhäufigkeit für Grauwert j im beschränkten Grauerthistogramm darstellt und hu_j die Histogrammhäufigkeit für Grauwert j im unbeschränkten Grauerthistogramm darstellt, qm ein vorgegebener Exponent ist und der Maximalwert über den Bereich von Grauwerten ermittelt wird,

- Ermittlung des Abszissenwerts t_a des Stützpunktes durch Überprüfung in absteigender Folge der Sequenz von Gütezahlen fom_j für alle Grauwerte j , beginnend beim Grauwert, für den die Gütezahl den Maximalwert darstellt, und Gleichstellen von t_a mit dem ersten Grauwert, für den die entsprechende Gütezahl unter einem vorgegebenen Schwellenwert Tfa liegt.

2. Verfahren nach Anspruch 1, **dadurch gekennzeichnet, dass** die Gradationskurve eine zusammengesetzte Kurve ist, bestehend aus zumindest drei angrenzenden Segmenten, d.h. einem Fußsegment, das einen Bereich $[t_0, t_f]$ umspannt, einem mittleren Segment, das einen Bereich $[t_f, t_s]$ umspannt, und einem Schultersegment, das einen Bereich $[t_s, t_1]$ umspannt, wobei diese Segmente kombiniert eine stetige Kurve mit einer stetigen Ableitung bilden, wobei das mittlere Segment eine vorgegebene mittlere Neigung aufweist.

EP 1 347 416 B1

3. Verfahren nach Anspruch 2, **dadurch gekennzeichnet, dass** das mittlere Segment geradlinig ist.
4. Verfahren nach Anspruch 2, **dadurch gekennzeichnet, dass** eine Erweiterung des Signalbereichs $[t_0, t_1]$ wie folgt erhalten wird :
- 5
- (a) durch Anpassen der Fußbreite unter Konstanthaltung der Fußhöhe oder
 - (b) durch Anpassen der Fußbreite unter Konstanthaltung der mittleren Neigung des Fußes oder
 - (c) durch Anpassen der Schulterbreite unter Konstanthaltung der Schulterhöhe oder
 - (d) durch Anpassen der Schulterbreite unter Konstanthaltung der mittleren Neigung der Schulter oder
 - (e) durch Anpassung von sowohl der Fußbreite als der Schulterbreite nach einem der vorstehenden Basisanpassungsschemas (a) bis (d).
- 10
5. Verfahren nach Anspruch 1, **dadurch gekennzeichnet, dass** die Signaldarstellung durch Bestrahlung eines Gegenstands mit einer Strahlendosis, Detektierung der durch den Gegenstand abgeschwächten Strahlung mittels eines Strahlungsdetektors und Umwandlung der detektierten Strahlung in eine digitale Signaldarstellung erhalten wird,
- 15
- und **dadurch gekennzeichnet, dass** die Gradationskurve in einem Koordinatensystem definiert ist, in dem Abszissenwerte als eine Menge, die in solchem Zusammenhang mit der Strahlendosis steht, dass der Rauschwert des Bildes nahezu unabhängig vom Pixelwert ist, ausgedrückt werden und in dem Ordinatenwerte eine wahrnehmbare lineare Menge darstellen.
- 20
6. Verfahren nach Anspruch 1, **dadurch gekennzeichnet, dass** ein Abszissenwert die Quadratwurzel der durch den Detektor in einem entsprechenden Pixel erfassten Dosis ist.
- 25
7. Verfahren nach Anspruch 1, **dadurch gekennzeichnet, dass** der Stützpunkt Koordinatenwerte (t_a, y_a) hat, wobei t_a auf der Basis einer charakteristischen Position auf der Pixelwertachse eines Histogramms des Bildes definiert wird.
8. Verfahren nach Anspruch 2, **dadurch gekennzeichnet, dass** t_0 und t_1 aus der Signaldarstellung des Bildes abgeleitet werden.
- 30
9. Verfahren nach Anspruch 2, **dadurch gekennzeichnet, dass** die untere Schranke des Fußsegments t_0 auf einen vorgegebenen Wert y_0 gemappt wird.
10. Verfahren nach Anspruch 9, **dadurch gekennzeichnet, dass** y_0 gleich dem kleinsten Wert ist, den eine das Bild wiedergebende Anzeige oder ein das Bild wiedergebendes Wiedergabegerät oder -material anzeigen kann.
- 35
11. Ein Verfahren nach Anspruch 2, **dadurch gekennzeichnet, dass** die untere Schranke des Fußsegments durch folgende Schritte ermittelt wird :

- 40
- Ermittlung eines unbeschränkten Grauwertistogramms des Bildes,
 - Ermittlung eines beschränkten Grauwertistogramms unter Beschränkung auf Pixel, die in einem binären Maskenbild mit den gleichen Abmessungen wie das Bild mittels eines Flags als relevant markiert sind,
 - Berechnung einer Gütezahl f_{om_j} für jeden Grauwert j im Bild durch Anwendung der Formel :
- 45

$$f_{om_j} = \frac{hr_j \cdot hu_j^{-q_m}}{\max_j (hr_j \cdot hu_j^{-q_m})}$$

50

- in der hr_j die Histogrammhäufigkeit für Grauwert j im beschränkten Grauwertistogramm darstellt und hu_j die Histogrammhäufigkeit für Grauwert j im unbeschränkten Grauwertistogramm darstellt, q_m ein vorgegebener Exponent ist und der Maximalwert über den Bereich von Grauwerten ermittelt wird,
- 55
- Ermittlung des Abszissenwerts t_0 durch Überprüfung in aufsteigender Folge der Sequenz von Gütezahlen f_{om_j} für alle Grauwerte j , beginnend beim minimalen Grauwert, und Gleichstellen von t_0 mit dem ersten Grauwert, für den die entsprechende Gütezahl oberhalb eines vorgegebenen Schwellenwerts T_{f_0} liegt.

EP 1 347 416 B1

12. Verfahren nach Anspruch 2, **dadurch gekennzeichnet, dass** die obere Schranke des Schultersegments t1 auf einen vorgegebenen Wert y1 gemappt wird.

13. Verfahren nach Anspruch 12, **dadurch gekennzeichnet, dass** y1 gleich dem höchsten Wert ist, den eine das Bild wiedergebende Anzeige oder ein das Bild wiedergebendes Wiedergabegerät oder Wiedergabematerial anzeigen kann.

14. Ein Verfahren nach Anspruch 2, **dadurch gekennzeichnet, dass** die obere Schranke des Schultersegments durch folgende Schritte ermittelt wird :

- Ermittlung eines unbeschränkten Grauerthistogramms des Bildes,
- Ermittlung eines beschränkten Grauerthistogramms unter Beschränkung auf Pixel, die in einem binären Maskenbild mit den gleichen Abmessungen wie das Bild mittels eines Flags als relevant markiert sind,
- Berechnung einer Gütezahl fom_j für jeden Grauwert j im Bild durch Anwendung der Formel :

$$fom_j = \frac{hr_j \cdot hu_j^{-qm}}{\max_j(hr_j \cdot hu_j^{-qm})}$$

in der hr_j die Histogrammhäufigkeit für Grauwert j im beschränkten Grauerthistogramm darstellt und hu_j die Histogrammhäufigkeit für Grauwert j im unbeschränkten Grauerthistogramm darstellt, qm ein vorgegebener Exponent ist und der Maximalwert über den Bereich von Grauwerten ermittelt wird,

- Ermittlung des Abszissenwerts t1 durch Überprüfung in absteigender Folge der Sequenz von Gütezahlen fom_j für alle Grauwerte j, beginnend beim maximalen Grauwert, und Gleichstellen von t1 mit dem ersten Grauwert, für den die entsprechende Gütezahl oberhalb eines vorgegebenen Schwellenwerts $Tf1$ liegt.

15. Ein Verfahren zur Gradationsverarbeitung einer digitalen Signaldarstellung eines Bildes durch Anwendung einer Gradationskurve, **dadurch gekennzeichnet, dass** die Gradationskurve nach einem Verfahren nach einem der Ansprüche 1 bis 14 erstellt wird.

16. Ein Computerprogrammprodukt, das so ausgelegt ist, dass es bei Verwendung auf einem Computer die Ausführung des Verfahrens nach einem der vorstehenden Ansprüche sichert.

17. Ein computerlesbares Medium, enthaltend einen auf einem Computer ausführbaren Programmcode, der so definiert ist, dass er die Ausführung der Schritte nach einem der vorstehenden Ansprüche sichert.

Revendications

1. Un procédé pour la génération d'une courbe de gradation pour le traitement de gradation d'une image représentée par une représentation par signaux numériques afin de générer une image à gradation traitée, **caractérisé en ce que** la forme de la courbe de gradation et la gamme de signaux pour laquelle la courbe de gradation est tracée, sont dérivées de la représentation par signaux numériques et que la courbe de gradation présente une valeur d'ordonnée prédéfinie et une pente prédéfinie à un point d'ancrage, **caractérisé en ce que** la valeur d'abscisse ta du point d'ancrage est déterminée :

- en déterminant un histogramme de niveaux de gris non limité de l'image,
- en déterminant un histogramme de niveaux de gris limité de l'image et ce en limitant l'histogramme à des pixels dont le drapeau est activé dans une image de masque binaire ayant les mêmes dimensions que l'image,
- en calculant un facteur de mérite fom_j pour chaque niveau de gris j dans l'image en appliquant la formule :

EP 1 347 416 B1

$$fom_j = \frac{hr_j \cdot hu_j^{-qm}}{\max_j(hr_j \cdot hu_j^{-qm})}$$

- 5
- 10 où hr_j représente la fréquence de l'histogramme pour le niveau de gris j dans l'histogramme de niveaux de gris limité et hu_j représente la fréquence de l'histogramme pour le niveau de gris j dans l'histogramme de niveaux de gris non limité, qm représente un exposant prédéfini et la valeur maximale est déterminée sur la gamme de niveaux de gris,
- 15 - en déterminant la valeur d'abscisse ta du point d'ancrage en vérifiant, dans l'ordre descendant, la séquence de facteurs de mérite fom_j pour tous les niveaux de gris j à partir du niveau de gris pour lequel le facteur de mérite représente la valeur maximale et en rendant la valeur ta égale au premier niveau de gris pour lequel le facteur de mérite correspondant est inférieur à un seuil Tfa prédéfini.
- 20
2. Procédé selon la revendication 1, **caractérisé en ce que** la courbe de gradation est une courbe composite composée d'au moins trois segments contigus, à savoir d'un segment de pied couvrant un intervalle $[t0,tf]$, d'un segment médian couvrant un intervalle $[tf,ts]$ et d'un segment d'épaule couvrant un intervalle $[ts,t1]$, la combinaison de ces trois segments formant une courbe continue ayant une dérivée continue, le segment médian présentant une pente moyenne prédéfinie.
- 25
3. Procédé selon la revendication 2, **caractérisé en ce que** le segment médian est rectiligne.
- 30
4. Procédé selon la revendication 2, **caractérisé en ce qu'**un élargissement de la gamme de signaux $[t0,t1]$ est obtenu :
- (a) en adaptant la largeur du pied sans modifier la hauteur du pied ou
- (b) en adaptant la largeur du pied sans modifier la pente moyenne du pied ou
- (c) en adaptant la largeur de l'épaule sans modifier la hauteur de l'épaule ou
- (d) en adaptant la largeur de l'épaule sans modifier la pente moyenne de l'épaule ou
- (e) en adaptant tant la largeur du pied que la largeur de l'épaule selon l'un quelconque des schémas d'adaptation de base (a) à (d) repris ci-dessus.
- 35
5. Procédé selon la revendication 1, **caractérisé en ce que** la représentation par signaux est obtenue par exposition d'un objet à une dose de rayonnement, par détection du rayonnement atténué par l'objet à l'aide d'un détecteur de rayonnement et par conversion du rayonnement détecté en une représentation par signaux numériques, et **caractérisé en ce que** la courbe de gradation est définie dans un système de coordonnées dans lequel des valeurs d'abscisse sont exprimées comme une quantité dont la corrélation avec la dose de rayonnement est telle
- 40 que la valeur de bruit de l'image est pratiquement indépendante de la valeur de pixel, et dans lequel des valeurs d'ordonnée représentent une quantité linéaire observable.
- 45
6. Procédé selon la revendication 1, **caractérisé en ce qu'**une valeur d'abscisse représente la racine carrée de la dose enregistrée par le détecteur dans un pixel correspondant.
- 50
7. Procédé selon la revendication 1, **caractérisé en ce que** le point d'ancrage présente des valeurs d'ordonnée (ta, ya), la valeur ta étant définie sur la base d'une position caractéristique sur l'axe des valeurs de pixel d'un histogramme de l'image.
- 55
8. Procédé selon la revendication 2, **caractérisé en ce que** les valeurs $t0$ et $t1$ sont dérivées de la représentation par signaux de l'image.
9. Procédé selon la revendication 2, **caractérisé en ce que** la borne inférieure du segment de pied $t0$ est positionnée sur une valeur $y0$ prédéfinie.
10. Procédé selon la revendication 9, **caractérisé en ce que** la valeur $y0$ est égale au plus bas niveau qu'un écran ou un appareil ou matériel de reproduction reproduisant l'image est capable de visualiser.

EP 1 347 416 B1

11. Procédé selon la revendication 2, **caractérisé en ce que** la borne inférieure du segment de pied est déterminée :

- en déterminant un histogramme de niveaux de gris non limité de l'image,
- en déterminant un histogramme de niveaux de gris limité et ce en le limitant à des pixels dont le drapeau est activé dans une image de masque binaire ayant les mêmes dimensions que l'image,
- en calculant un facteur de mérite fom_j pour chaque niveau de gris j dans l'image en appliquant la formule :

$$fom_j = \frac{hr_j \cdot hu_j^{-qm}}{\max_j(hr_j \cdot hu_j^{-qm})}$$

où hr_j représente la fréquence de l'histogramme pour le niveau de gris j dans l'histogramme de niveaux de gris limité et hu_j représente la fréquence de l'histogramme pour le niveau de gris j dans l'histogramme de niveaux de gris non limité, qm représente un exposant prédéfini et la valeur maximale est déterminée sur la gamme de niveaux de gris,

- en déterminant la valeur d'abscisse $t0$ en vérifiant, dans l'ordre ascendant, la séquence de facteurs de mérite fom_j pour tous les niveaux de gris j à partir du niveau de gris minimal et en rendant la valeur $t0$ égale au premier niveau de gris pour lequel le facteur de mérite correspondant est supérieur à un seuil $Tf0$ prédéfini.

12. Procédé selon la revendication 2, **caractérisé en ce que** la borne supérieure du segment d'épaule $t1$ est positionnée sur une valeur $y1$ prédéfinie.

13. Procédé selon la revendication 12, **caractérisé en ce que** la valeur $y1$ est égale au plus haut niveau qu'un écran ou un appareil ou matériel de reproduction reproduisant l'image est capable de visualiser.

14. Procédé selon la revendication 2, **caractérisé en ce que** la borne supérieure du segment d'épaule est déterminée :

- en déterminant un histogramme de niveaux de gris non limité de l'image,
- en déterminant un histogramme de niveaux de gris limité et ce en le limitant à des pixels dont le drapeau est activé dans une image de masque binaire ayant les mêmes dimensions que l'image,
- en calculant un facteur de mérite fom_j pour chaque niveau de gris j dans l'image en appliquant la formule :

$$fom_j = \frac{hr_j \cdot hu_j^{-qm}}{\max_j(hr_j \cdot hu_j^{-qm})}$$

où hr_j représente la fréquence de l'histogramme pour le niveau de gris j dans l'histogramme de niveaux de gris limité et hu_j représente la fréquence de l'histogramme pour le niveau de gris j dans l'histogramme de niveaux de gris non limité, qm représente un exposant prédéfini et la valeur maximale est déterminée sur la gamme de niveaux de gris,

- en déterminant la valeur d'abscisse $t1$ en vérifiant, dans l'ordre descendant, la séquence de facteurs de mérite fom_j pour tous les niveaux de gris j à partir du niveau de gris maximal et en rendant la valeur $t1$ égale au premier niveau de gris pour lequel le facteur de mérite correspondant est supérieur à un seuil $Tf1$ prédéfini.

15. Un procédé pour le traitement de gradation d'une représentation par signaux numériques d'une image en appliquant une courbe de gradation, **caractérisé en ce que** la courbe de gradation est générée selon un procédé selon l'une quelconque des revendications 1 à 14.

16. Un produit de programme informatique qui, lorsqu'il est appliqué sur un ordinateur, assure l'exécution du procédé selon l'une quelconque des revendications précédentes.

EP 1 347 416 B1

17. Un support lisible par ordinateur comprenant un code de programme exécutable sur ordinateur qui assure l'exécution des étapes selon l'une quelconque des revendications précédentes.

5

10

15

20

25

30

35

40

45

50

55

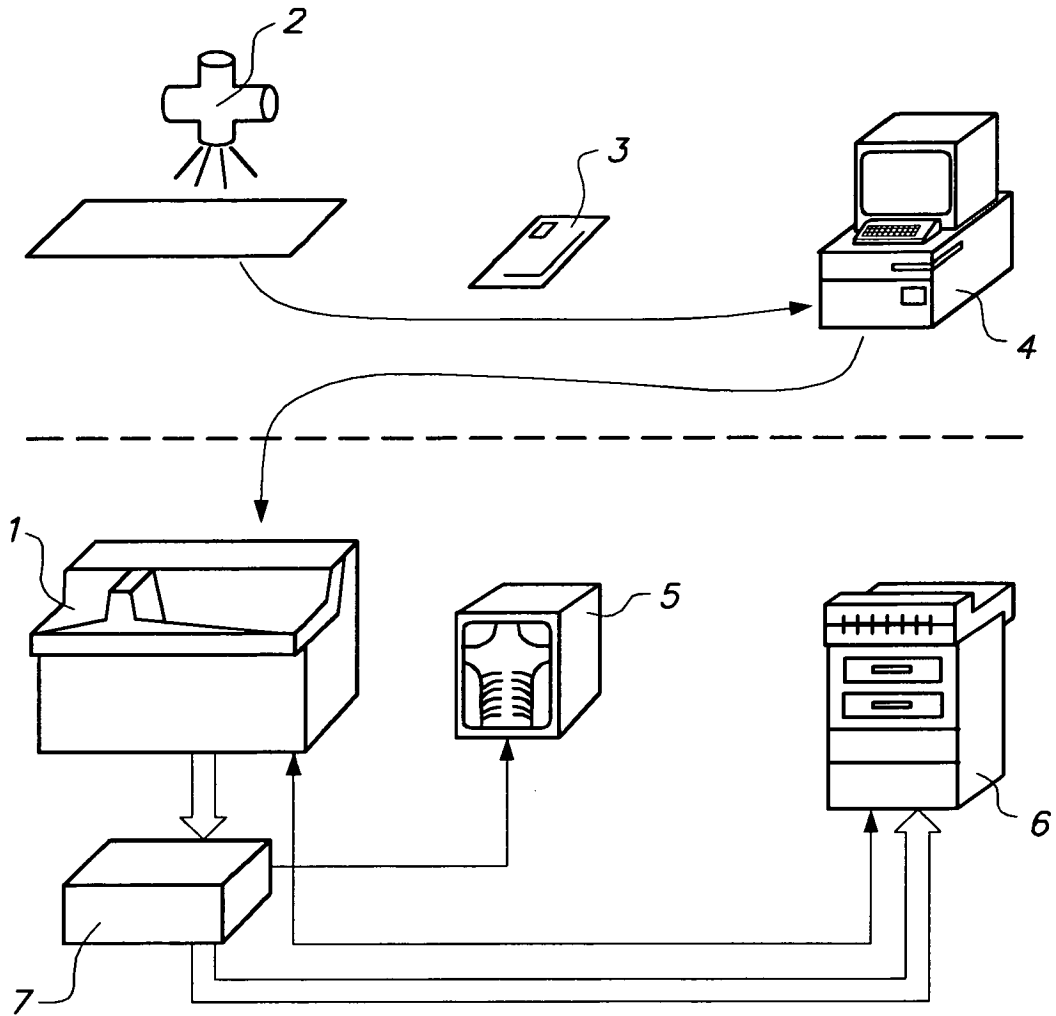

FIG. 1

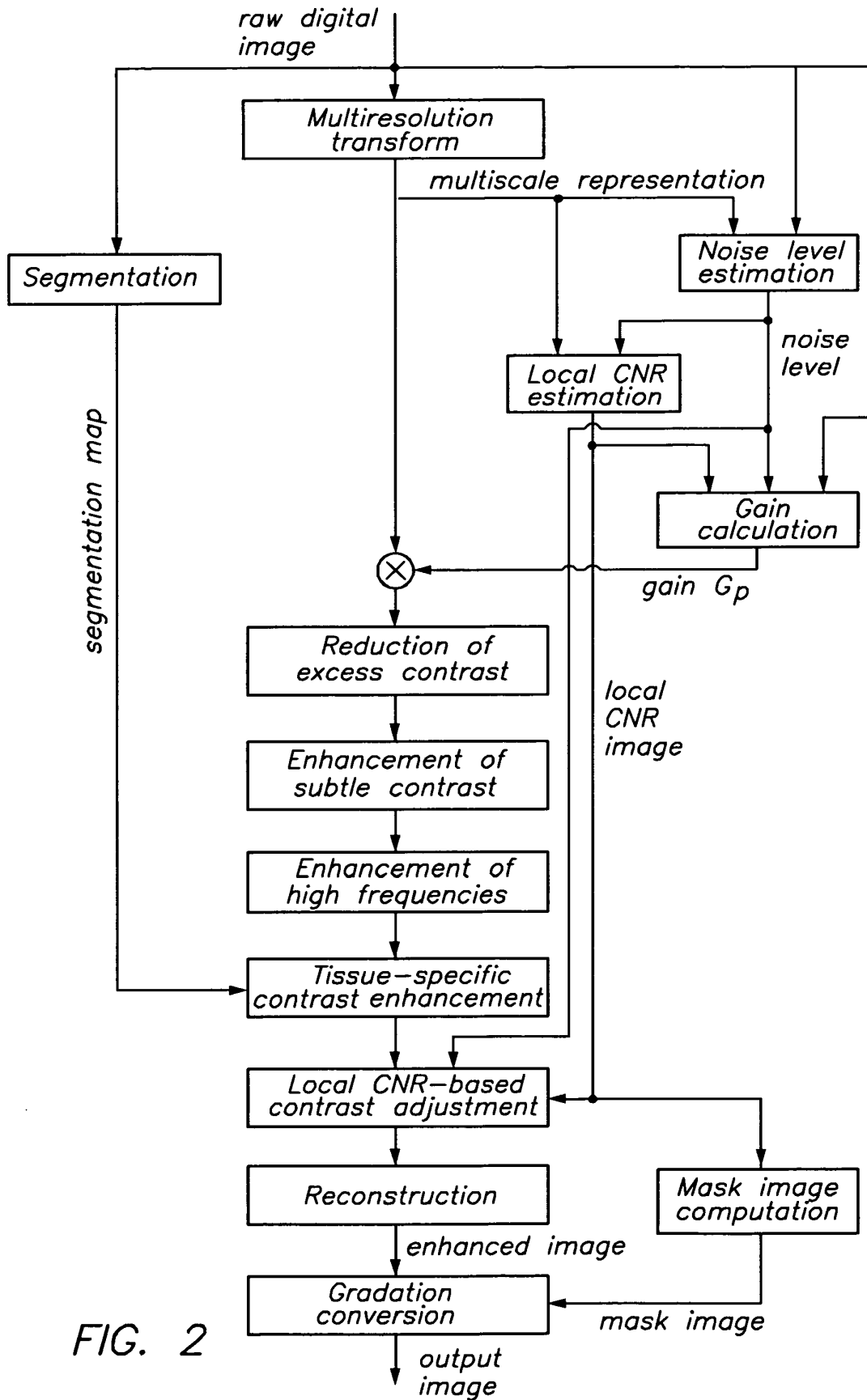

FIG. 2

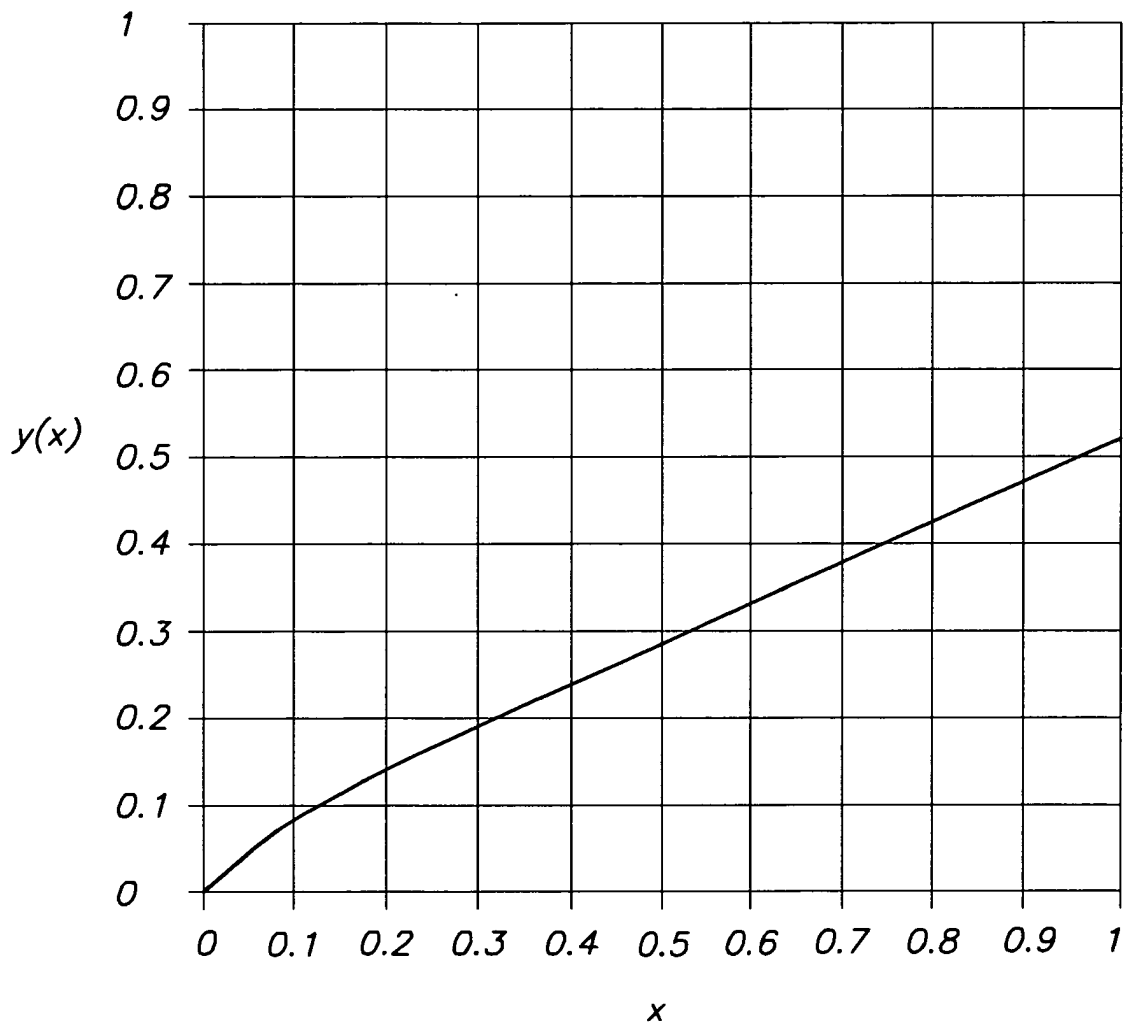

FIG. 3

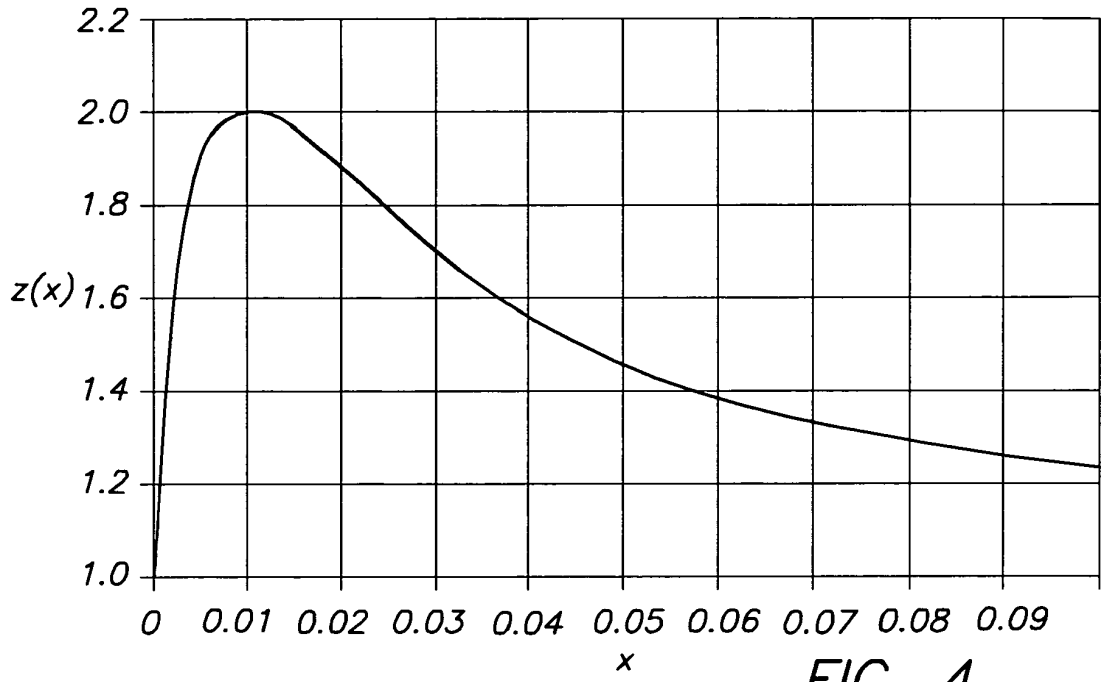

FIG. 4

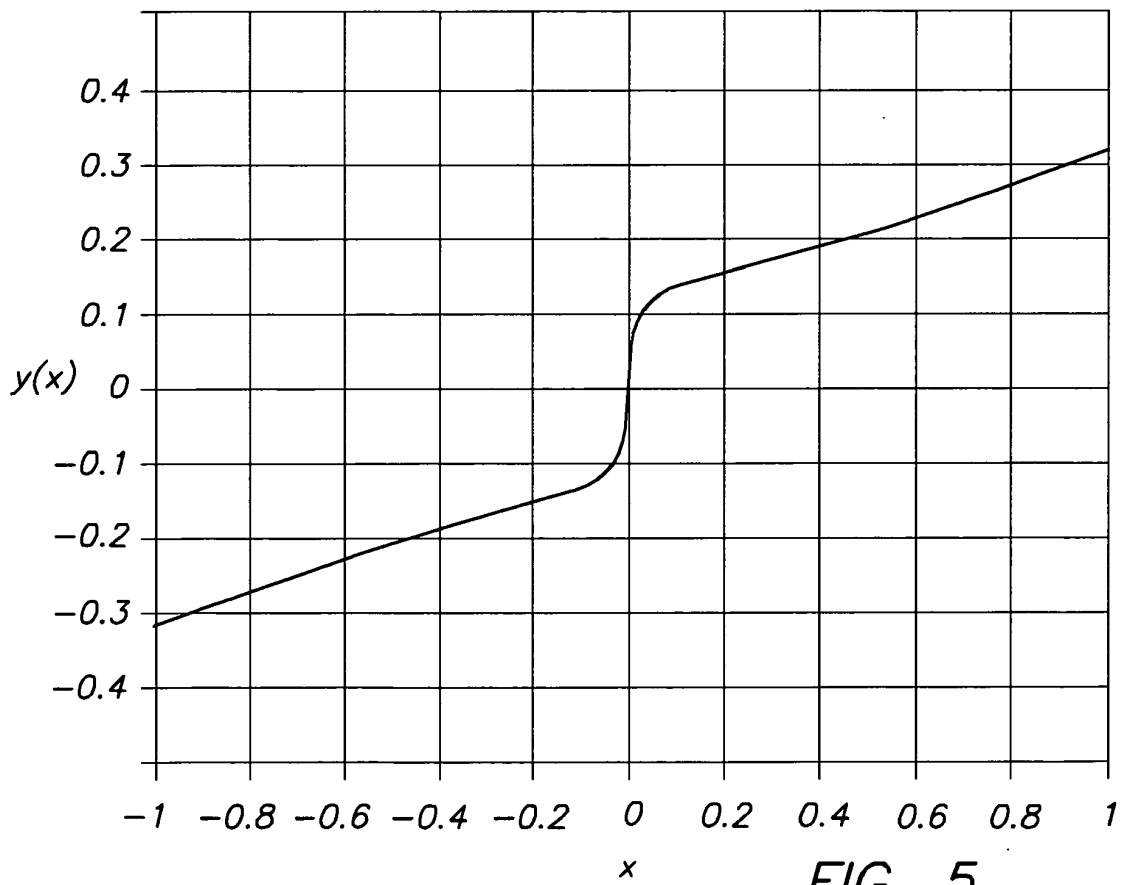
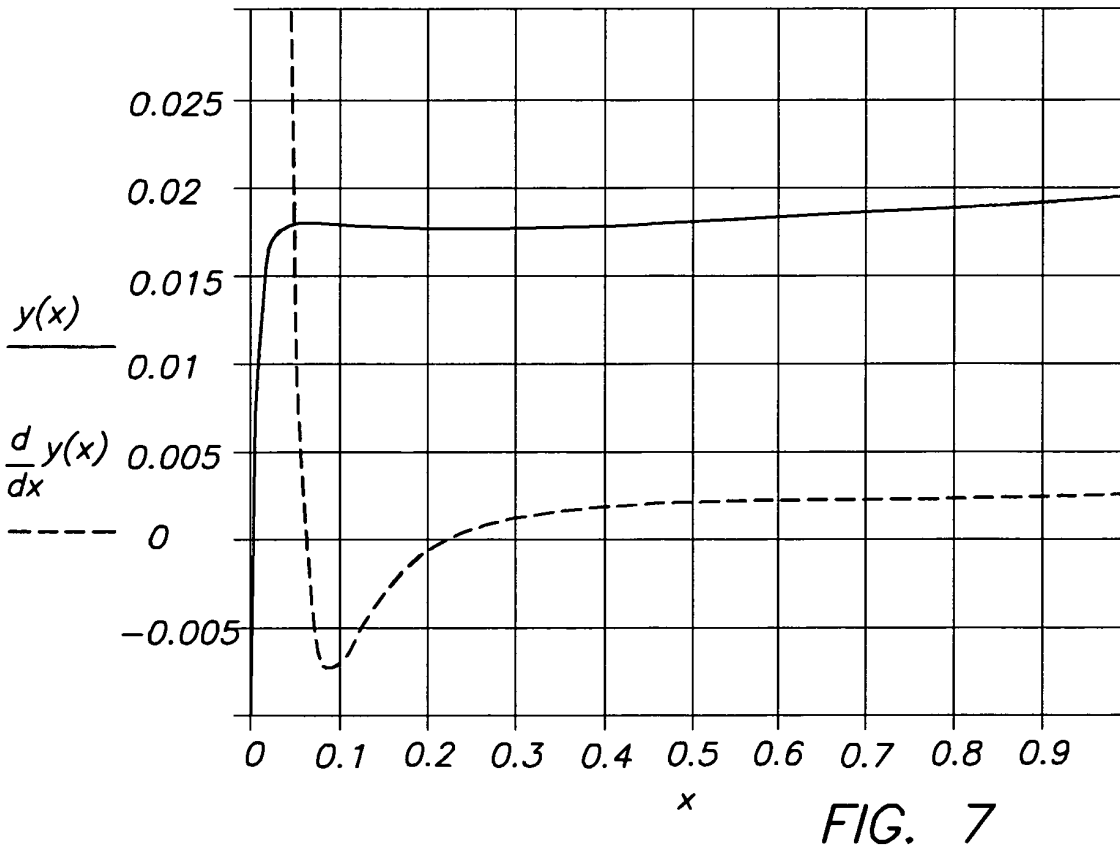
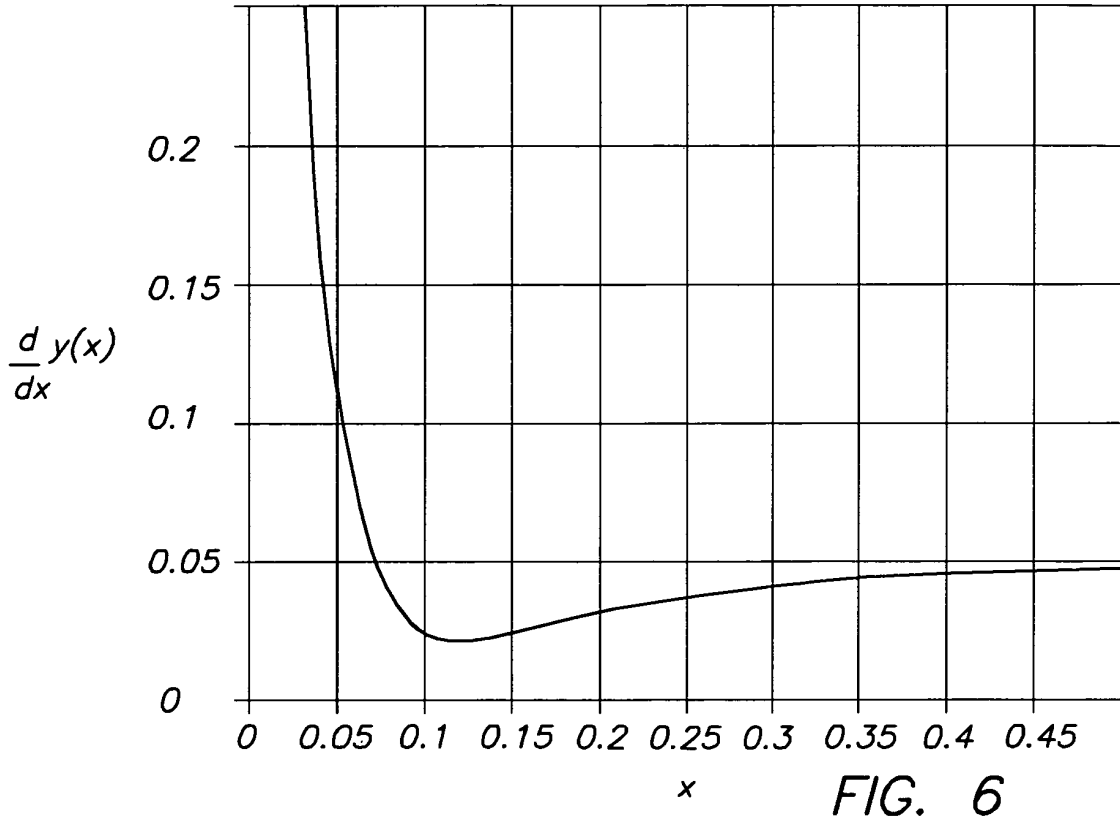

FIG. 5



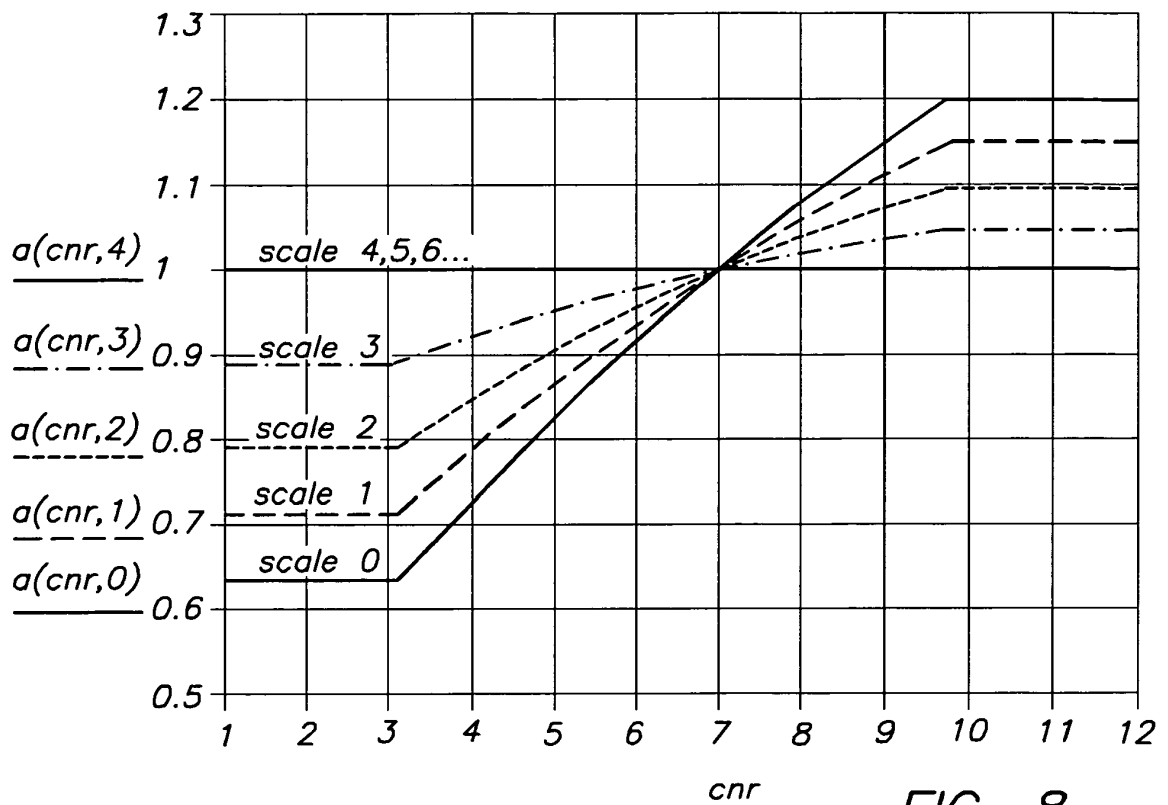

FIG. 8

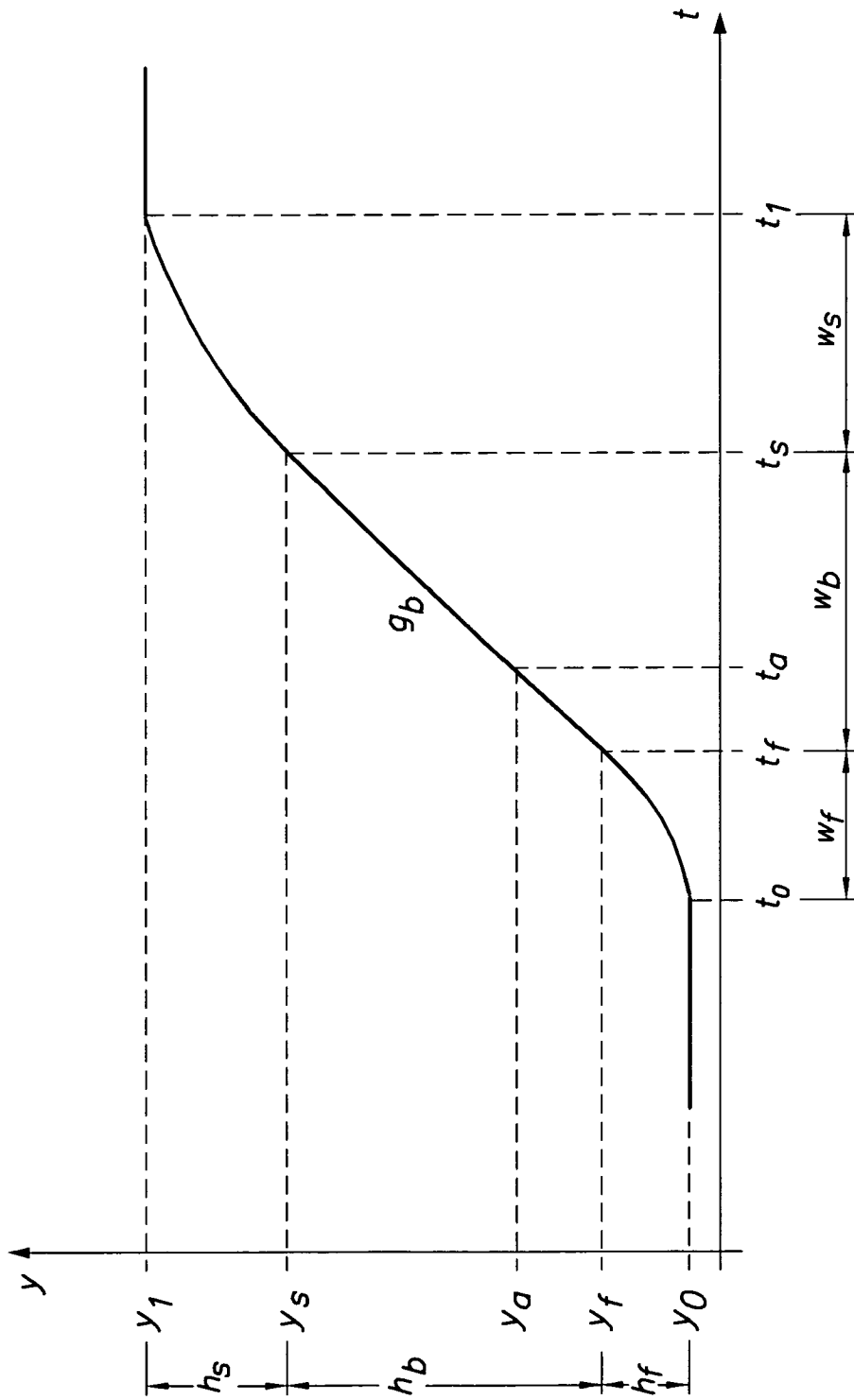

FIG. 9

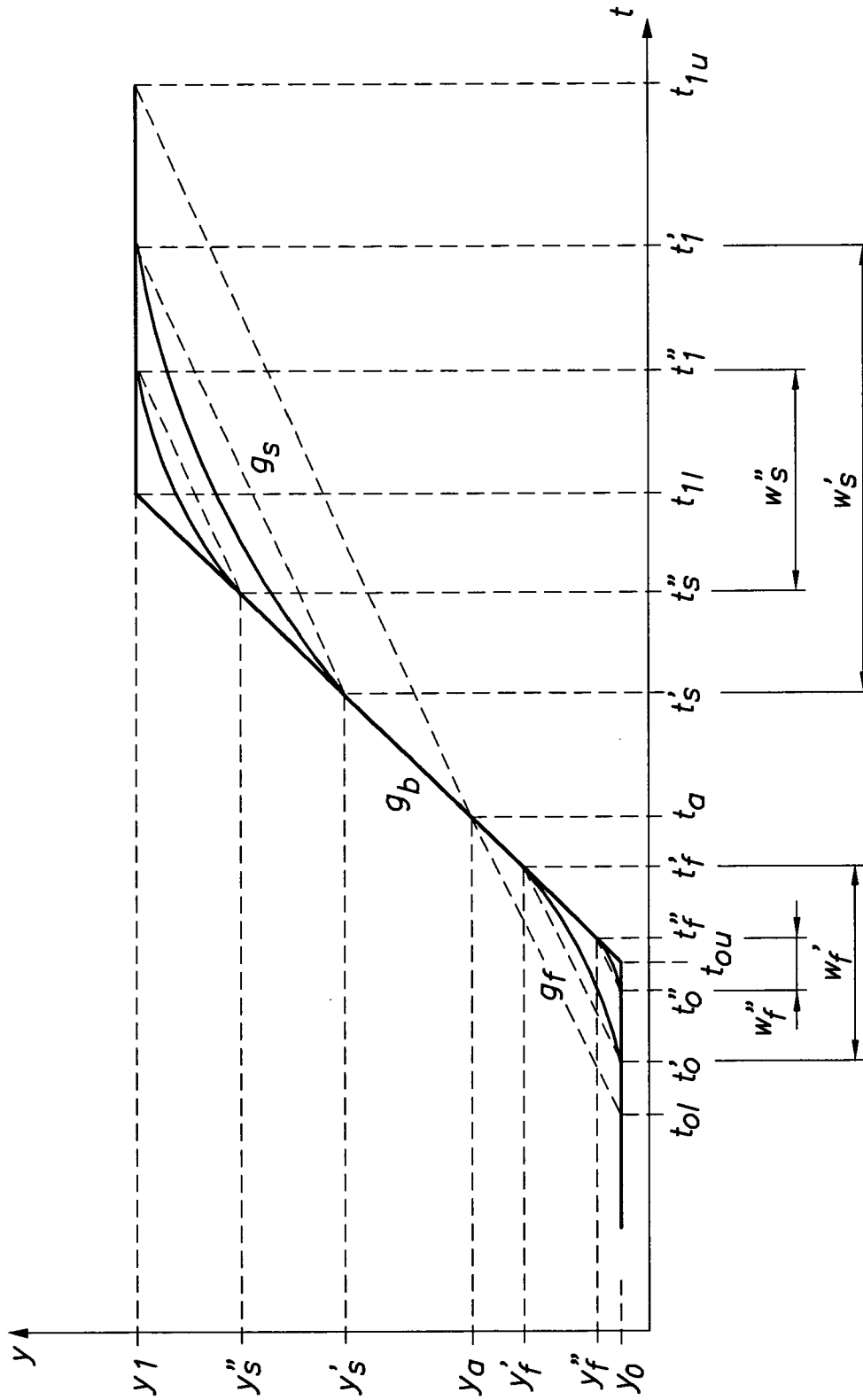

FIG. 10

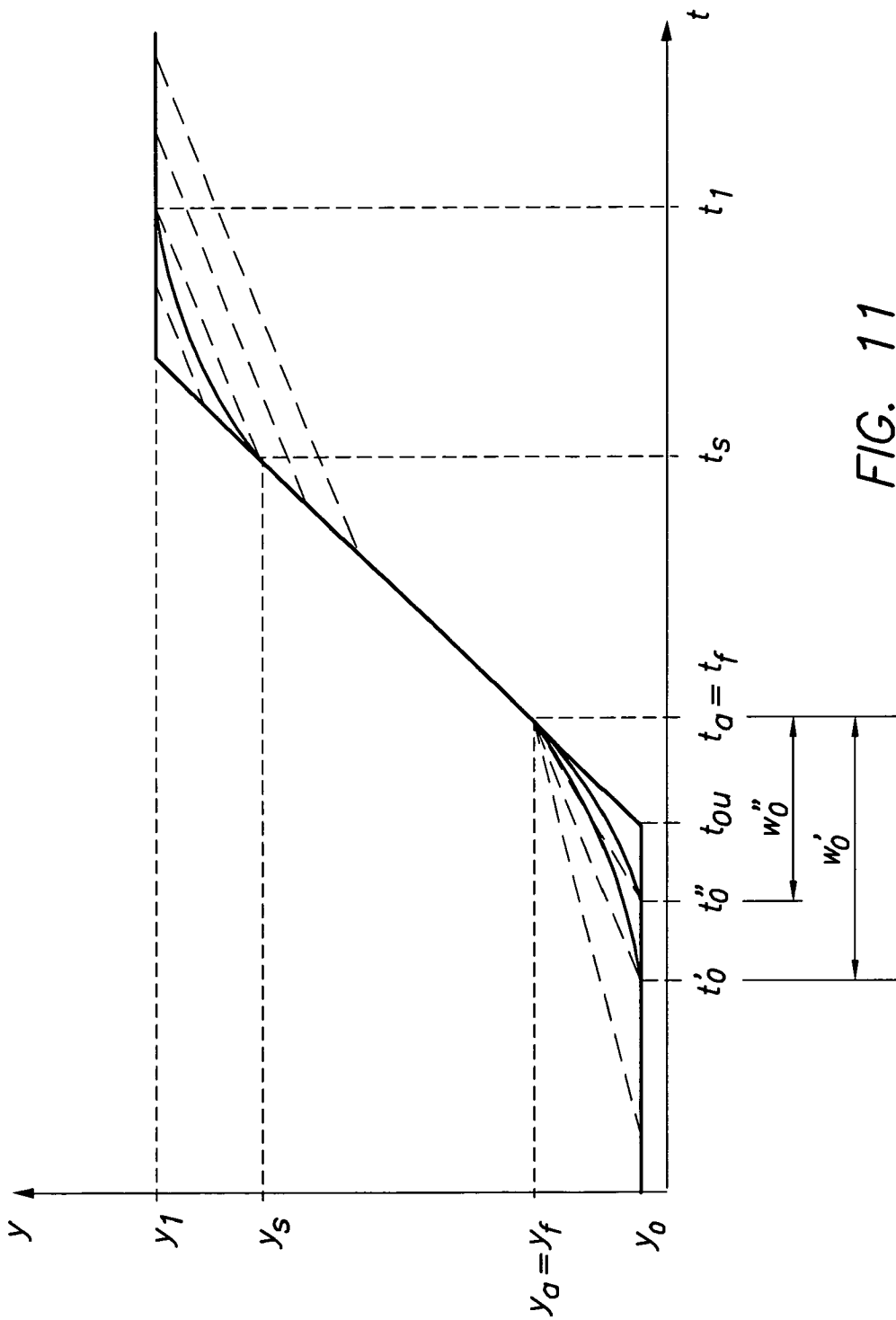

FIG. 11

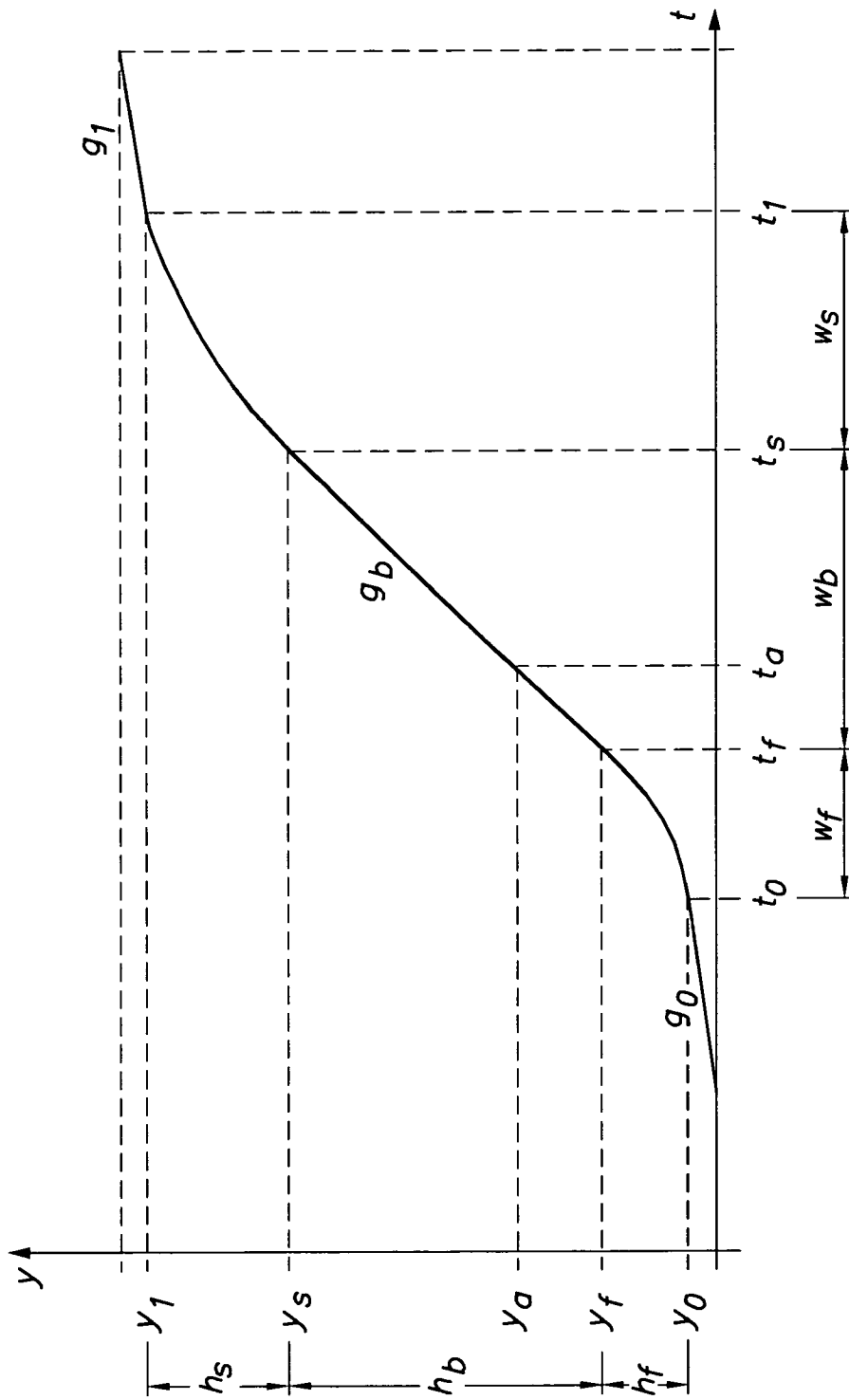

FIG. 12

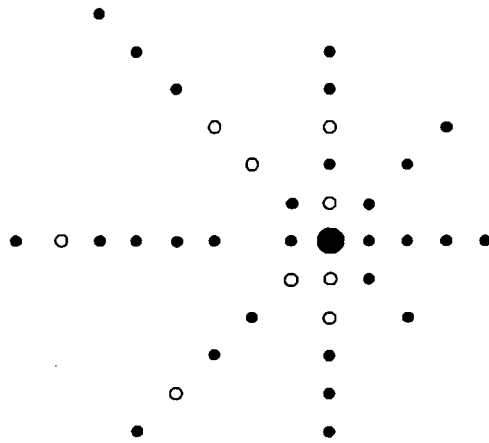

FIG. 13

REFERENCES CITED IN THE DESCRIPTION

This list of references cited by the applicant is for the reader's convenience only. It does not form part of the European patent document. Even though great care has been taken in compiling the references, errors or omissions cannot be excluded and the EPO disclaims all liability in this regard.

Patent documents cited in the description

- EP 527525 A [0011] [0085]
- EP 0110185 A [0018]
- EP 549009 A [0019]
- US 5164993 A [0033]
- US 4276473 A [0035]
- EP 574969 A [0166]

Non-patent literature cited in the description

- **S.K. Pakin ; R.S. Gaborski ; L.L. Barski ; D.H. Foos ; K.J. Parker.** Segmentation of Bone and Soft Tissue Regions in Digital Radiographic Images of Extremities. *SPIE Proc.*, 2001, vol. 4322, 1296-1302 [0161]

专利名称(译)	分级处理方法		
公开(公告)号	EP1347416B1	公开(公告)日	2010-04-28
申请号	EP2002100181	申请日	2002-02-22
申请(专利权)人(译)	爱克发·吉华集团		
当前申请(专利权)人(译)	爱克发医疗NV		
[标]发明人	VUYLSTEKE PIETER		
发明人	VUYLSTEKE, PIETER		
IPC分类号	G06T5/40 A61B5/00 A61B6/00 G06T5/00 H04N1/407		
CPC分类号	G06T5/009 G06T5/40 G06T2207/20012 G06T2207/20016 G06T2207/30004		
其他公开文献	EP1347416A1		
外部链接	Espacenet		

摘要(译)

一种创建用于由数字信号表示表示的医学图像的灰度处理的灰度曲线以生成灰度处理图像的方法，其中，从数字信号表示中推导出灰度曲线的形状和定义了灰度曲线的信号范围。并且其中灰度处理的图像在诊断上最相关的区域中具有固定的密度和固定的对比度值。

$$sdev = \sqrt{\frac{\sum_{i=1}^N (a_i)^2}{N}}$$