

(19)



Europäisches Patentamt
European Patent Office
Office européen des brevets



(11)

EP 1 174 078 B1

(12)

EUROPEAN PATENT SPECIFICATION

(45) Date of publication and mention
of the grant of the patent:
02.11.2006 Bulletin 2006/44

(51) Int Cl.:
A61B 5/00^(2006.01) A61B 5/15^(2006.01)

(21) Application number: **01115692.4**

(22) Date of filing: **05.07.2001**

(54) **Hollow microneedle patch**

Mikrohohlnadelpflaster

Timbre pour microaiguilles creuses

(84) Designated Contracting States:
**AT BE CH CY DE DK ES FI FR GB GR IE IT LI LU
MC NL PT SE TR**

(30) Priority: **11.07.2000 US 217424 P**

(43) Date of publication of application:
23.01.2002 Bulletin 2002/04

(73) Proprietor: **BAYER CORPORATION
Pittsburgh, PA 15205-9741 (US)**

(72) Inventor: **Whitson, Robert C.
Goshen,
Indiana 46528 (US)**

(74) Representative: **Linhart, Angela
Bayer HealthCare AG
CAO Law & Patents
Patents & Licensing
51368 Leverkusen (DE)**

(56) References cited:
**WO-A-00/35530 WO-A-99/64580
US-A- 5 723 284**

EP 1 174 078 B1

Note: Within nine months from the publication of the mention of the grant of the European patent, any person may give notice to the European Patent Office of opposition to the European patent granted. Notice of opposition shall be filed in a written reasoned statement. It shall not be deemed to have been filed until the opposition fee has been paid. (Art. 99(1) European Patent Convention).

Description**FIELD OF THE INVENTION**

[0001] The present invention relates generally to blood monitoring devices, and, more particularly, to a test patch for painlessly obtaining a sample of blood.

BACKGROUND OF THE INVENTION

[0002] It is often necessary to quickly and painlessly obtain a sample of blood and perform a quick analysis of the blood. One example of a need for painlessly obtaining a sample of blood is in connection with a blood glucose monitoring system where a user must frequently use the system to monitor the user's blood glucose level.

[0003] Those who have irregular blood glucose concentration levels are medically required to regularly self-monitor their blood glucose concentration level. An irregular blood glucose level can be brought on by a variety of reasons including illness such as diabetes. The purpose of monitoring the blood glucose concentration level is to determine the blood glucose concentration level and then to take corrective action, based upon whether the level is too high or too low, to bring the level back within a normal range. The failure to take corrective action can have serious implications. When blood glucose levels drop too low - a condition known as hypoglycemia - a person can become nervous, shaky, and confused. That person's judgment may become impaired and that person may eventually pass out. A person can also become very ill if their blood glucose level becomes too high - a condition known as hyperglycemia. Both conditions, hypoglycemia and hyperglycemia, are both potentially life-threatening emergencies.

[0004] One method of monitoring a person's blood glucose level is with a portable, hand-held blood glucose testing device. A prior art blood glucose testing device 100 is illustrated in FIG. 1. The portable nature of these devices 100 enables the users to conveniently test their blood glucose levels wherever the user may be. The glucose testing device contains a test sensor 102 to harvest the blood for analysis. The device 100 contains a switch 104 to activate the device 100 and a display 106 to display the blood glucose analysis results. In order to check the blood glucose level, a drop of blood is obtained from the fingertip using a lancing device. A prior art lancing device 120 is illustrated in FIG. 2. The lancing device 120 contains a needle lance 122 to puncture the skin. Some lancing devices implement a vacuum to facilitate the drawing of blood. Once the requisite amount of blood is produced on the fingertip, the blood is harvested using the test sensor 102. The test sensor 102, which is inserted into a testing unit 100, is brought into contact with the blood drop. The test sensor 102 draws the blood to the inside of the test unit 100 which then determines the concentration of glucose in the blood. Once the results of the test are displayed on the display of the test unit 100, the

test sensor 102 is discarded. Each new test requires a new test sensor 102.

[0005] WO 99/64580 discloses microneedle devices for the transport of therapeutic and biological molecules across tissue barriers. The microneedle devices permit removal or sensing of body fluids at clinically relevant rates across skin or other tissue barriers without damage, pain, or irritation to the tissue. The microneedles are hollow and/or porous and have outer tapered walls.

[0006] WO 00/35530 discloses an insertion set for essentially painless insertion through tissue, including a substrate and at least one micro-piercing member coupled to the substrate to form a patch. The micro-piercing member has a predetermined length to pierce material to a predetermined depth to interact with the tissue. The predetermined length is long enough to pierce the tissue and short enough to avoid contacting the nerves in the tissue. Some types of insertion sets may include a fluorescent analyte detection compound or other detection compound to detect the level of an analyte in the tissue. The outer walls of the micro-piercing members have outer tapered walls.

[0007] One problem associated with some conventional lancing devices is that there is a certain amount of pain associated with the lancing of a finger tip. Diabetics must regularly self-test themselves several times per day. Each test requires a separate lancing, each of which involves an instance of pain for the user.

[0008] Another problem associated with some conventional lancing devices is that the lacerations produced by the lances are larger than necessary and consequently take a greater time to heal. The greater the amount of time for the wound to heal translates into a longer period of time in which the wound is susceptible to infection.

[0009] Another problem associated with some conventional blood glucose monitoring devices is that the user's blood physically contacts the elements within the testing unit. Cross-contamination can be a problem if the monitoring device is used by more than one user such as a clinical setting.

SUMMARY OF THE INVENTION

[0010] According to one embodiment of the present invention, a test strip is provided for use in the determination of the concentration of a chemical in blood. The test strip comprises an array of hollow microneedles and a test chamber. Each microneedle is adapted to puncture skin and to draw blood. The test chamber is in fluid communication with the microneedles. The test chamber contains a reagent adapted to produce a reaction indicative of the concentration of the chemical in blood. Each of the microneedles contains an inlet and an outlet, said inlet being adapted to puncture skin, the outlet being in fluid communication with the test chamber. Each hollow microneedle has a cylindrical wall with the inside of the cylindrical wall being parallel to the outside of the cylindrical wall, the end portions of the cylindrical wall at the

inlet is sloped such that the inside of the cylindrical wall is shortened compared to the outside of the cylindrical wall.

[0011] The above summary of the present invention is not intended to represent each embodiment, or every aspect, of the present invention. Additional features and benefits of the present invention will become apparent from the detailed description, figures, and claims set forth below.

BRIEF DESCRIPTION OF THE DRAWINGS

[0012] Other objects and advantages of the invention will become apparent upon reading the following detailed description in conjunction with the drawings in which:

FIG. 1 is a top view of a prior art blood glucose testing device;

FIG. 2 is a perspective view of a prior art lance;

FIG. 3 is a perspective view of a microneedle patch according to one embodiment of the present invention;

FIG. 4 is a cross-sectional view of the embodiment of the microneedle patch illustrated in FIG. 3;

FIG. 5 is another cross-sectional view of the embodiment of the microneedle patch illustrated in FIG. 3;

FIG. 6 is a collection point of a microneedle;

FIG. 7 is a collection point of a microneedle according to the present invention;

FIG. 8 is a collection point of a microneedle;

FIG. 9 is an embodiment of a blood glucose monitoring device for use in conjunction with a microneedle patch according to a sixth alternative embodiment of the present invention;

FIG. 10 is an embodiment of a blood glucose monitoring device for use in conjunction with a microneedle patch according to a seventh alternative embodiment of the present invention;

FIG. 11 is an embodiment of a blood glucose monitoring system according to an eighth alternative embodiment of the present invention; and

FIG. 12 is an embodiment of a blood glucose monitoring system according to a ninth alternative embodiment of the present invention.

DETAILED DESCRIPTION OF THE PREFERRED EMBODIMENTS

[0013] Referring now to Figure 3, a hollow microneedle patch 200 according to one embodiment of the present invention is illustrated. The microneedle patch 200 comprises a plurality of hollow microneedles 202 coupled to a test chamber 204. Blood is moved through each of the plurality of microneedles 202 by capillary action to the test chamber 204. In the illustrated embodiment of the present invention, the plurality of hollow microneedles 202 are arranged in a twenty by twenty array so that the microneedle patch 200 includes four hundred hollow

microneedles 202. The microneedle patch 200 is used to lance a user's skin and to harvest a sample of blood. Essentially, the microneedle patch 200 integrates the prior art test sensor 102 and the lance 120 (discussed in conjunction with FIGS. 1 and 2) into a single unit.

[0014] Each microneedle penetrates the skin to a depth of about two-hundredths of an inch (0.02 inch = 0.508 mm). The microneedles 202 extend below the surface of the skin a distance sufficient to collect a sample of blood from the outermost layer of capillaries. The skin's outer layer, called the stratum corneum, does not contain any nerve endings. The first extensive nerve layer is disposed below the outermost layer of capillaries. Because each of the microneedles 202 do not contact any nerves, the lancing of the skin and the collection of blood is essentially painless. Further, because the lacerations created in the skin are much smaller than those created by a conventional lance, the risk of infection is lessened and the healing of the lacerations is expedited. The precise dimensions of the microneedles 202 and the microneedle 200 patch are a function of several variables including the amount of blood to be harvested and the type of blood glucose analysis to be used in conjunction with the microneedle patch 200.

[0015] Referring now to FIGS. 4 and 5, the microneedle patch 200 is illustrated pressed onto a user's skin 206 causing each of the microneedles 202 to penetrate the skin 206. Each of the microneedles 202 are hollow and have a collection point 208 and an outlet 210. The outlet 210 of each microneedle 202 is coupled to the test chamber 204. After penetrating the skin 206, blood 212 is collected through the collection point 208 of each of the microneedles 202. The blood 212 is moved through an interior 214 of the hollow microneedles 202 by capillary action to the test chamber 204. The requisite volume of blood 212 necessary for accurate testing is dependent on the type of glucose analysis employed. For example, the applicant has found that at least approximately one micro-liter of blood 212 is necessary to employ electrochemical analysis to determine the blood glucose concentration. Each of the plurality of microneedles 202 draws a portion of the requisite volume of blood 212 into the test chamber 204 where the analysis occurs.

[0016] A reagent 215 is incorporated in the test chamber 204 of the microneedle patch 200. Once blood is moved into the test chamber 204, the glucose in the blood 212 reacts with the reagent 215 in the test chamber 204 to produce a detectable signal. That signal is then measured by a sensor which can measure the concentration of the glucose in the blood 212 based on the signal. The specific reagent 215 incorporated into the test chamber 204 is a function of the type of sensing employed to determine the concentration of glucose in the blood 212.

[0017] In operation, a user can measure the concentration of the user's blood by pressing the microneedle patch 200 onto the user's skin. Each of the microneedles 202 lances the skin 206. A quantity of blood 212 is moved by capillary action from the collection point 208 of each

microneedle 202 to the test chamber 204. The glucose in the blood 212 reacts with a reagent 215 incorporated into the test chamber 204 producing a signal indicative of the blood glucose concentration. That signal is then measured with an appropriate sensor in a blood glucose analyzer to determine the concentration of glucose in the user's blood. Once the blood glucose analyzer measures the signal produced by the reaction, the microneedle patch 200 can be discarded.

[0018] An advantage to the use of the microneedle patch 200 is that blood never comes into contact with the blood glucose analyzer. Therefore, in addition to self-testing, the microneedle patch 200 may be used at a clinical level because cross-contamination is not an issue. For example, a doctor may use a single blood glucose analyzer to test the blood glucose concentration for that doctor's patients. One microneedle patch 200 would be used for each patient. The microneedle patch is pressed onto the patient's skin and the signal produced by the reaction within the microneedle patch 200 is read by a blood glucose analyzer which never contacts the patient's blood. The blood glucose analyzer can be used again while the use microneedle patch 200, containing the sample of blood, is discarded.

[0019] Referring to FIGS. 6, 7 and 8, three alternatives of the collection point of each microneedle 202 are illustrated. Figures 6 and 8 illustrate examples not forming part of the present invention. Each microneedle 202 of the present invention is generally shaped as a hollow cylinder having cylindrical walls 230. In FIG. 6, the collection point of the microneedle 202 is an angled collection point 232. A plane parallel to the angled collection point 232 is disposed at an angle relative to the longitudinal axis of the microneedle 202.

[0020] According to the invention, the microneedle 202 has a generally concave collection point 234 as illustrated in FIG. 7. The generally cylindrical walls 230 of the microneedle 202 are formed upwardly sloping radially away from the longitudinal axis of the microneedle 202 at the collection point 234.

[0021] In another example the microneedle 202 has a generally convex collection point 236 is illustrated in FIG. 8. In the example illustrated in FIG. 8, the generally cylindrical walls 230 of the microneedles 202 are formed downwardly sloping radially away from the longitudinal axis of the microneedle 202 at the collection point 236. The shape of the alternatives of the collections points illustrated in FIGS. 6-8 reduce surface tension at the collection point of the microneedle 202 thus facilitating the movement of blood from the collection point through the hollow microneedle 202 to the test chamber 104.

[0022] Colorimetric analysis is one type of analysis that can be utilized with the microneedle patch 200 of the present invention. The reaction of the glucose and a specific reagent produces a change in color, or a colorimetric reaction, which is indicative of the amount of glucose in the blood. That color change can be compared to a color chart, wherein the colors on the color chart were obtained

using blood having a known glucose concentration, to determine the blood glucose concentration. The color change in the test chamber 204 caused by the reaction of the glucose and the reagent 215 can be read with a spectrophotometric instrument incorporated into a glucose monitoring device for use with the patch 200. In such an embodiment where colorimetric sensing is employed, a back side 218 (FIG. 4) of the test sensor 204 may be transparent allowing the glucose monitoring device to optically detect the color change.

[0023] Alternatively, electrochemical analysis is another type of analysis which may be utilized in conjunction with the microneedle patch 200 of present invention to determine the concentration of glucose in a user's blood. In such an embodiment, the test chamber 104 includes a pair of electrodes. In electrochemical analysis, the change in current across the electrodes caused by the reaction of the glucose and the reagent is indicative of the concentration of the glucose in the blood. The reaction of the glucose and the reagent creates an oxidation current at the electrode which is directly proportional to the user's blood glucose concentration. This current can be measured by an appropriate sensor implemented in an glucose monitoring device for use with the patch 200.

The glucose monitoring device can then communicate to the user the blood glucose concentration. Both colorimetric and electrochemical testing systems are described in detail by commonly-owned U.S. Patent No. 5,723,284 entitled "Control Solution and Method for Testing the Performance of an Electrochemical Device for Determining the Concentration of an Analyte in Blood".

[0024] Referring now to FIG. 9, a glucose monitoring device 300 having a colorimetric sensor (a spectrophotometric instrument) 302 which may used in conjunction with the microneedle array patch 200 is illustrated. The test chamber 204 of the microneedle array patch 200 contains appropriate reagents designed to react with glucose in a manner to produce a change in color indicative of the glucose concentration in the user's blood. The glucose monitoring device 300 having a colorimetric sensor 302 determines the glucose concentration and informs the user of the result. The monitoring device 300 is activated with a switch 304. After the microneedle array patch 200 is pressed onto the user's skin and the requisite amount of time has past for the reaction to occur, the monitoring device 300 is brought into close proximity to the microneedle array patch 200 to read the colorimetric signal produced by the reaction. The test chamber 204 has a transparent back cover 218 allowing the colorimetric sensor 302 in the monitoring device 300 to optically read the signal. The monitoring then determines the blood glucose concentration and communicates those results to the user via a display 306. The microneedle patch 200 can then be removed and discarded.

[0025] Alternatively, electrochemical sensing can be employed in conjunction with the microneedle array path of the present invention. FIG. 10 illustrates a suitable monitoring device 320 which can be used in conjunction

with an embodiment of the microneedle patch 200 designed for electrochemical sensing. The embodiment of the microneedle patch 200 designed for electrochemical sensing contains a pair of electrodes 352. The blood glucose monitoring device 320 contains a pair of corresponding electrodes 353 (shown in FIG. 12). The blood glucose monitoring device 350 is activated with a switch 354. Once the microneedle patch 200 is pressed onto a user's skin and a requisite amount of time has passed for the electrochemical reaction to occur, the electrodes 352 of the monitoring device are brought into contact with the corresponding electrodes 353 on the microneedle patch 200. The results of the blood glucose analysis are communicated to the user via a display 356.

[0026] Referring now to FIG. 11, another application of the microneedle patch 200 of the present invention is in an integrated blood glucose monitoring system 350 which integrates the microneedle array patch 200 and a blood glucose analyzer into a single instrument. The integrated blood glucose monitoring system contains a plurality of microneedle patches 200 and when activated moves a new microneedle patch 200 to the test end 352 of the system 350. In operation, a user would activate the system 350 with a switch 354. A new microneedle patch 200 is advanced to the test end 352 of the system 350. The user would then press the test end 352 of the system against the user's skin causing each of the microneedles 202 in the array of microneedles 202 to lance the user's skin and to harvest the blood sample. Once the requisite blood sample has been obtained and the requisite time has elapsed for the reaction in the test chamber 204 of the microneedle patch 200 to occur, the blood glucose monitoring system 350 determines the blood glucose concentration and communicates the result to the user via a display 356. The used microneedle array patch is then ejected from the system 350. Both electrochemical sensing and colorimetric sensing as well as other types of blood glucose analysis may be implemented within the blood glucose monitoring system 350 of the present invention.

[0027] Referring now to FIG. 12, another alternative embodiment of the present invention is illustrated wherein the microneedle patch 200 has an adhesive 360 disposed on an upper surface 362 of the microneedle patch 200 in another alternative embodiment of the present invention. The adhesive 360 holds the microneedle patch 200 against a user's skin 206. The adhesive 360 is useful in an embodiment of the microneedle patch 200 wherein a longer period of time is required for the harvesting of the blood sample and then the occurrence of the reaction between the glucose in the blood and the reagent disposed in the test chamber 204. Also illustrated in FIG. 12 are the pair of electrodes 353 disposed in the test chamber 203.

[0028] While the invention is susceptible to various modifications and alternative forms, specific embodiments thereof have been shown by way of example in the drawings and will be described in detail herein. It

should be understood, however, that it is not intended to limit the invention to the particular forms disclosed, but, to the contrary, the intention is to cover all modifications, equivalents and alternatives falling within the scope of the invention as defined by the appended claims.

Claims

1. A test strip (200) for use in the determination of the concentration of a chemical in blood (212), comprising:

a plurality of hollow microneedles (202), each microneedle (202) being adapted to puncture skin (206) and to draw blood (212); and a test chamber (204) in fluid communication with the microneedles (202), the test chamber (204) containing a reagent (215) being adapted to produce a reaction indicative of the concentration of a chemical in blood (212),

wherein

each of the microneedles (202) containing an inlet (208,234) and an outlet (210), said inlet (208,234) being adapted to puncture skin (206), the outlet (210) being in fluid communication with the test chamber (204),

wherein

each hollow microneedle (202) has a cylindrical wall (230) with the inside of the cylindrical wall (230) being parallel to the outside of the cylindrical wall (230), **characterized in** the end portions of the cylindrical wall (230) at the inlet (208, 234) being sloped such that the inside of the cylindrical wall (230) is shortened compared to the outside of the cylindrical wall (230).

2. The test strip (200) of claim 1 wherein the reagent (215) is adapted to produce a colorimetric reaction.

3. The test strip (200) of claim 1 wherein the reagent (215) is adapted to produce an electrochemical reaction, the test strip (200) further comprising a pair of electrodes (353) coupled to the test chamber (204).

4. The test strip (200) of one of the claims 1 to 3 wherein the chemical is glucose.

5. The test strip (200) of claim 4 in combination with a sensor (302) adapted to measure the concentration of glucose in the blood (212).

6. The test strip (200) of claim 5 wherein the reagent (215) is adapted to produce a colorimetric reaction and the sensor (302) is a colorimetric sensor.

7. The test strip (200) of one of the claims 1 to 6 further comprising an adhesive (360) disposed on the top of the test chamber (204), the adhesive (360) being adapted to adhere the test chamber (204) to skin (206).

Patentansprüche

1. Teststreifen (220) zur Verwendung bei der Bestimmung der Konzentration einer chemischen Substanz im Blut (212), umfassend:

eine Vielzahl an hohlen Mikronadeln (202), wobei jede Mikronadel (202) dazu geeignet ist, Haut (206) zu durchstechen und Blut (212) einzusaugen; und
eine Testkammer (204), die zu den Mikronadeln (202) in Fluidkommunikation steht, wobei die Testkammer (204) ein Reagens (215) enthält, das dazu geeignet ist, eine Reaktion herbeizuführen, die die Konzentration einer chemischen Substanz im Blut (212) anzeigt, worin jede der Mikronadeln (202) einen Einlass (208, 234) und einen Auslass (210) umfasst, wobei der Einlass (208, 234) dazu geeignet ist, Haut (206) zu durchstechen, und der Auslass (210) mit der Testkammer (204) in Fluidkommunikation steht,

worin

jede hohle Mikronadel (202) eine zylindrische Wand (230) aufweist, wobei die Innenseite der zylindrischen Wand (230) parallel zur Außenseite der zylindrischen Wand (230) ist, **dadurch gekennzeichnet, dass** die Endabschnitte der zylindrischen Wand (230) am Einlass (208, 234) so abgeschrägt sind, dass die Innenseite der zylindrischen Wand (230) im Vergleich zur Außenseite der zylindrischen Wand (230) verkürzt ist.

2. Teststreifen (200) nach Anspruch 1, worin das Reagens (215) dazu geeignet ist, eine kolorimetrische Reaktion herbeizuführen.
3. Teststreifen (200) nach Anspruch 1, worin das Reagens (215) dazu geeignet ist, eine elektrochemische Reaktion herbeizuführen und der Teststreifen (200) weiters ein Elektrodenpaar (353) umfasst, das mit der Testkammer (204) gekoppelt ist.
4. Teststreifen (200) nach einem der Ansprüche 1 bis 3, worin die chemische Substanz Glucose ist.
5. Teststreifen (200) nach Anspruch 4 in Kombination mit einem Sensor (302), der dazu geeignet ist, die Konzentration von Glucose im Blut (212) zu messen.

6. Teststreifen (200) nach Anspruch 5, worin das Reagens (215) dazu geeignet ist, eine kolorimetrische Reaktion herbeizuführen und der Sensor (302) ein kolorimetrischer Sensor ist.

7. Teststreifen (200) nach einem der Ansprüche 1 bis 6, weiters umfassend ein an der Oberseite der Testkammer (204) bereitgestelltes Haftmittel (360), wobei das Haftmittel (360) dazu geeignet ist, die Testkammer (204) an der Haut (206) anzukleben.

Revendications

1. Bande (200) d'analyse pour une utilisation dans la détermination de la concentration d'une substance chimique dans le sang (212), comprenant :

une pluralité de micro-aiguilles creuses (202), chaque micro-aiguille (202) étant adaptée pour perforer la peau (206) et pour extraire du sang (212) ; et

une chambre (204) d'analyse en communication fluide avec les micro-aiguilles (202), la chambre (204) d'analyse contenant un réactif (215) qui est adapté pour produire une réaction indicative de la concentration d'une substance chimique dans le sang (212), dans laquelle chacune des micro-aiguilles (202) comportant une entrée (208, 234) et une sortie (210), ladite entrée (208, 234) étant adaptée pour perforer la peau (206), la sortie (210) étant en communication fluide avec la chambre (204) d'analyse, dans laquelle

chaque micro-aiguille creuse (202) comporte une paroi cylindrique (230), l'intérieur de la paroi cylindrique (230) étant parallèle à l'extérieur de la paroi cylindrique (230), **caractérisée en ce que** les parties d'extrémité de la paroi cylindrique (230) situées au niveau de l'entrée (208, 234) forment une inclinaison faisant que l'intérieur de la paroi cylindrique (230) est raccourci par comparaison avec l'extérieur de la paroi cylindrique (230).

2. Bande (200) d'analyse selon la revendication 1, dans laquelle le réactif (215) est adapté pour produire une réaction colorimétrique.
3. Bande (200) d'analyse selon la revendication 1, dans laquelle le réactif (215) est adapté pour produire une réaction électrochimique, la bande (200) d'analyse comprenant en outre une paire d'électrodes (353) couplées à la chambre (204) d'analyse.
4. Bande (200) d'analyse selon l'une des revendications 1 à 3, dans laquelle la substance chimique est du glucose.

5. Bande (200) d'analyse selon la revendication 4, en combinaison avec un capteur (302), adaptée pour mesurer la concentration de glucose dans le sang (212).
5
6. Bande (200) d'analyse selon la revendication 5, dans laquelle le réactif (215) est adapté pour produire une réaction colorimétrique et le capteur (302) est un capteur colorimétrique.
10
7. Bande (200) d'analyse selon l'une des revendications 1 à 6, comprenant en outre un adhésif (360) disposé au sommet de la chambre (204) d'analyse, l'adhésif (360) étant adapté pour que la chambre (204) d'analyse colle à la peau (206).
15

20

25

30

35

40

45

50

55

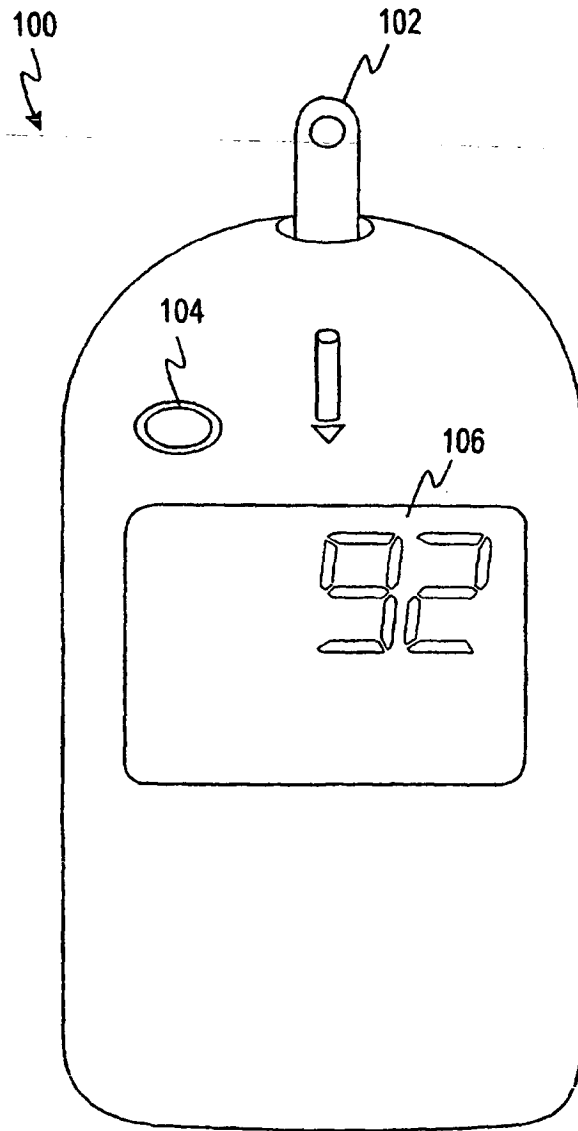

FIG. 1
(Prior Art)

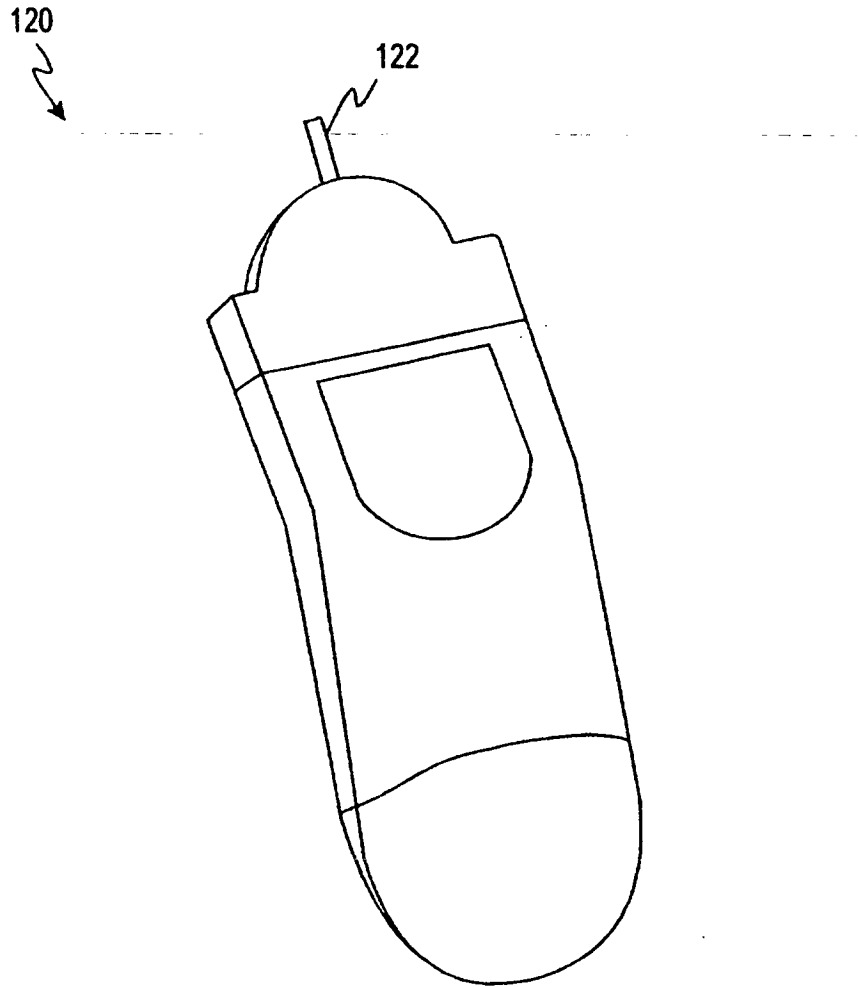

FIG. 2
(Prior Art)

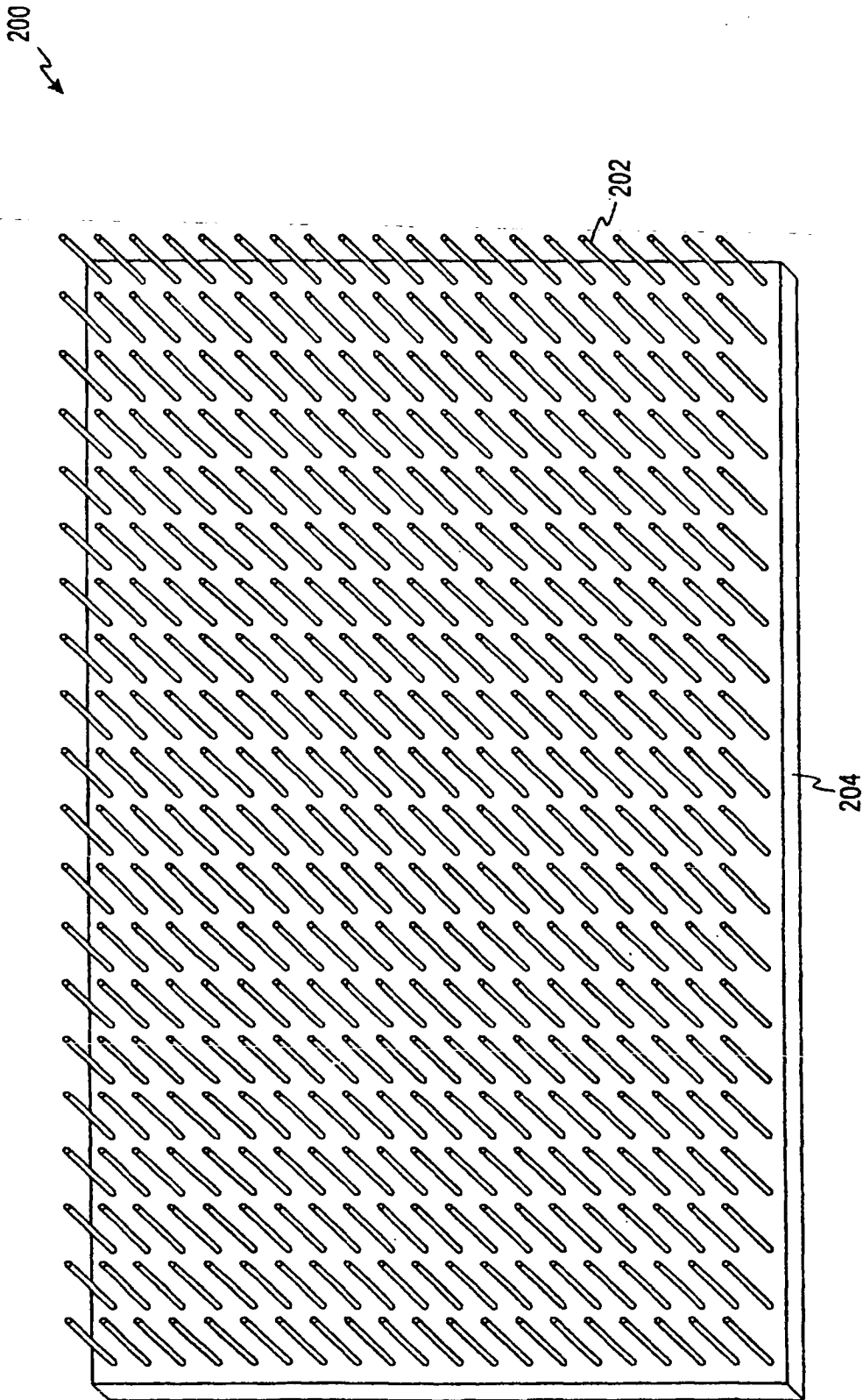

FIG. 3

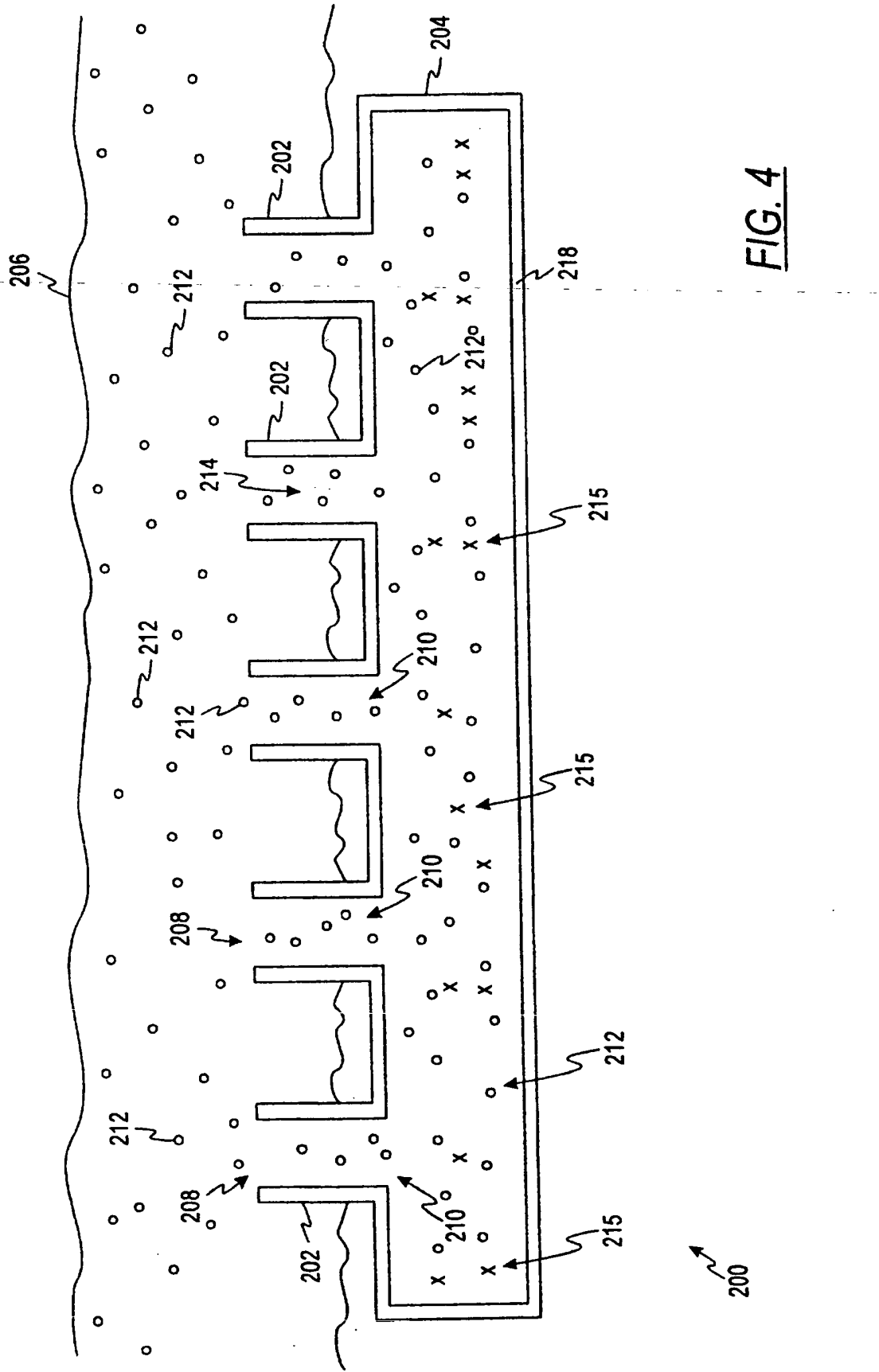

FIG. 4

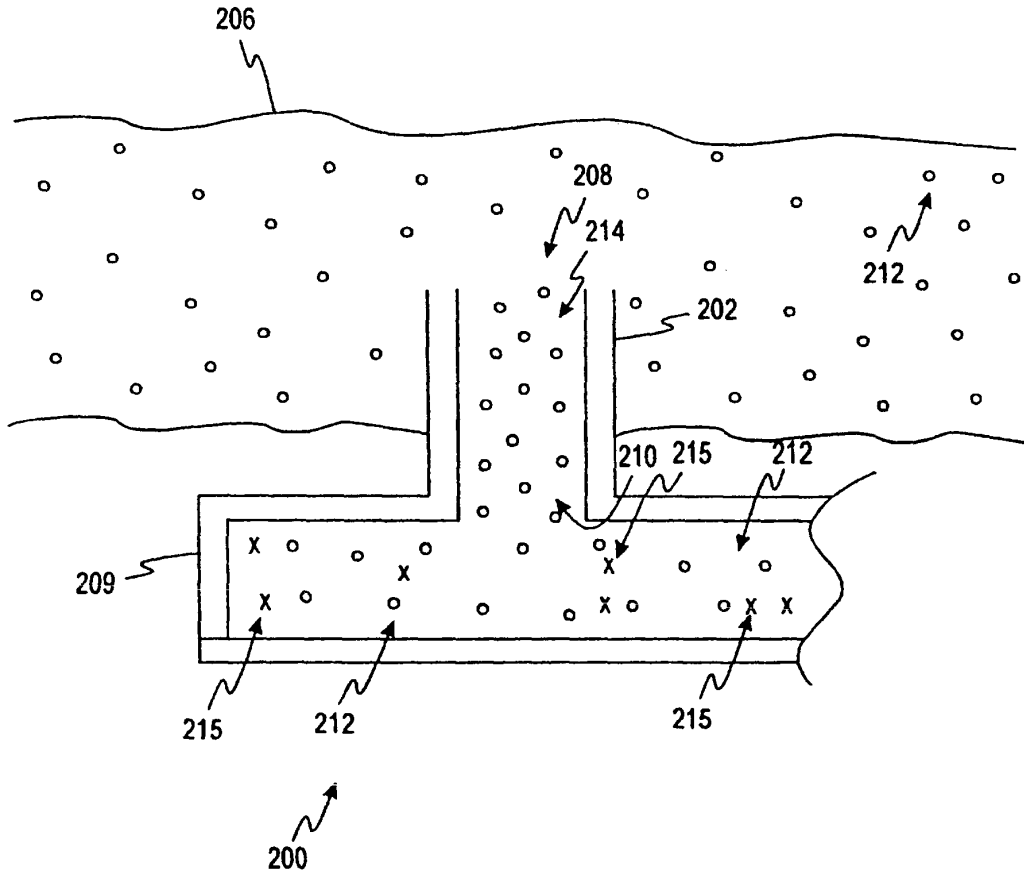

FIG. 5

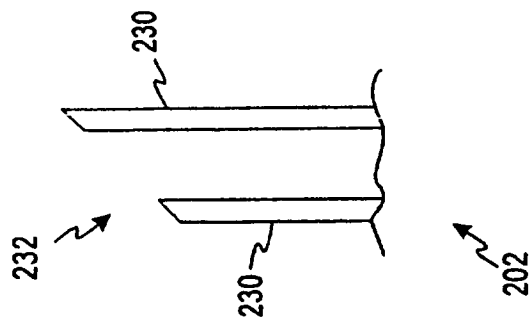

FIG. 6

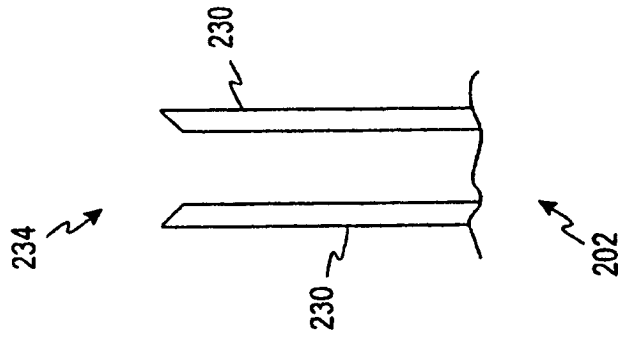

FIG. 7

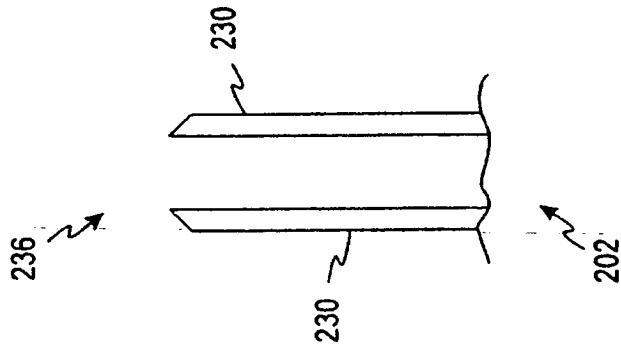

FIG. 8

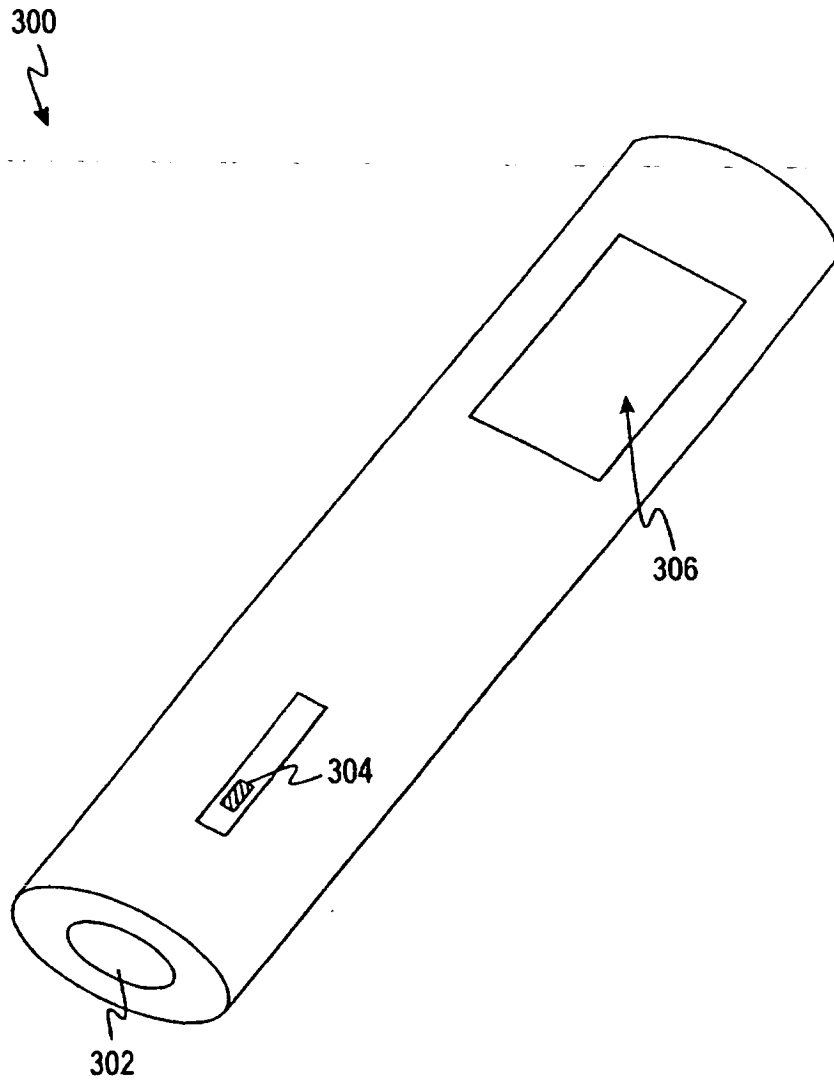

FIG. 9

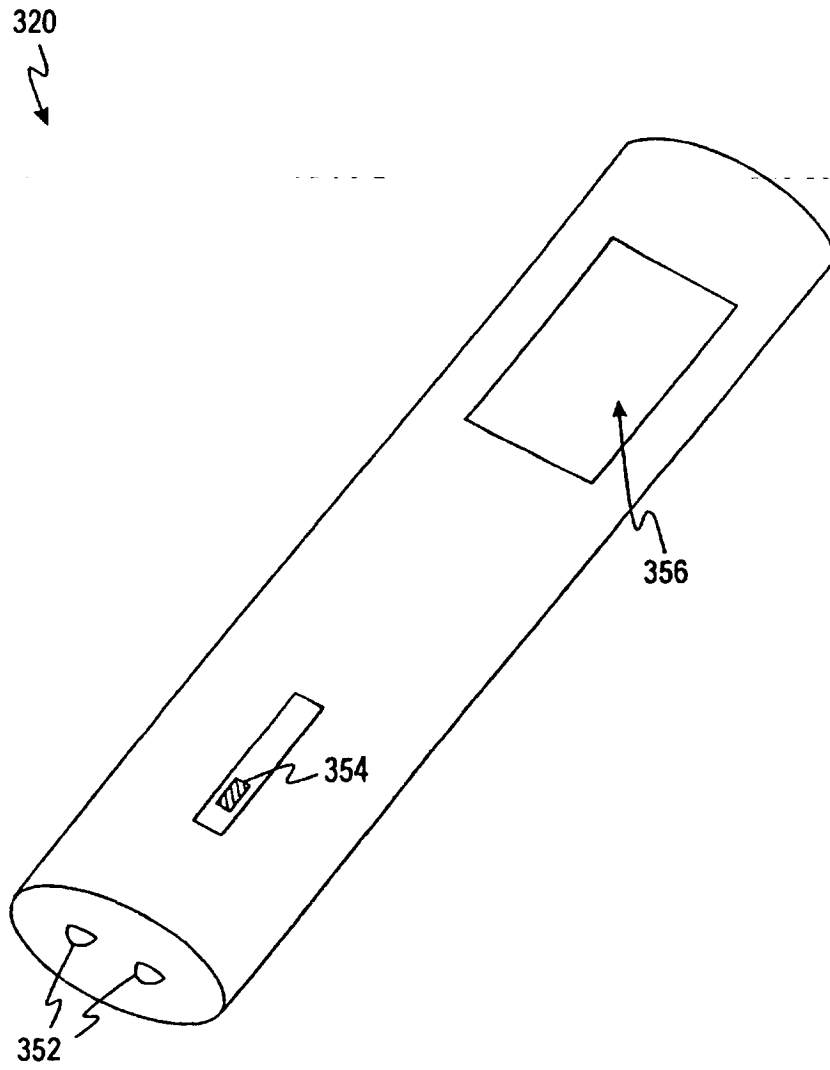

FIG. 10.

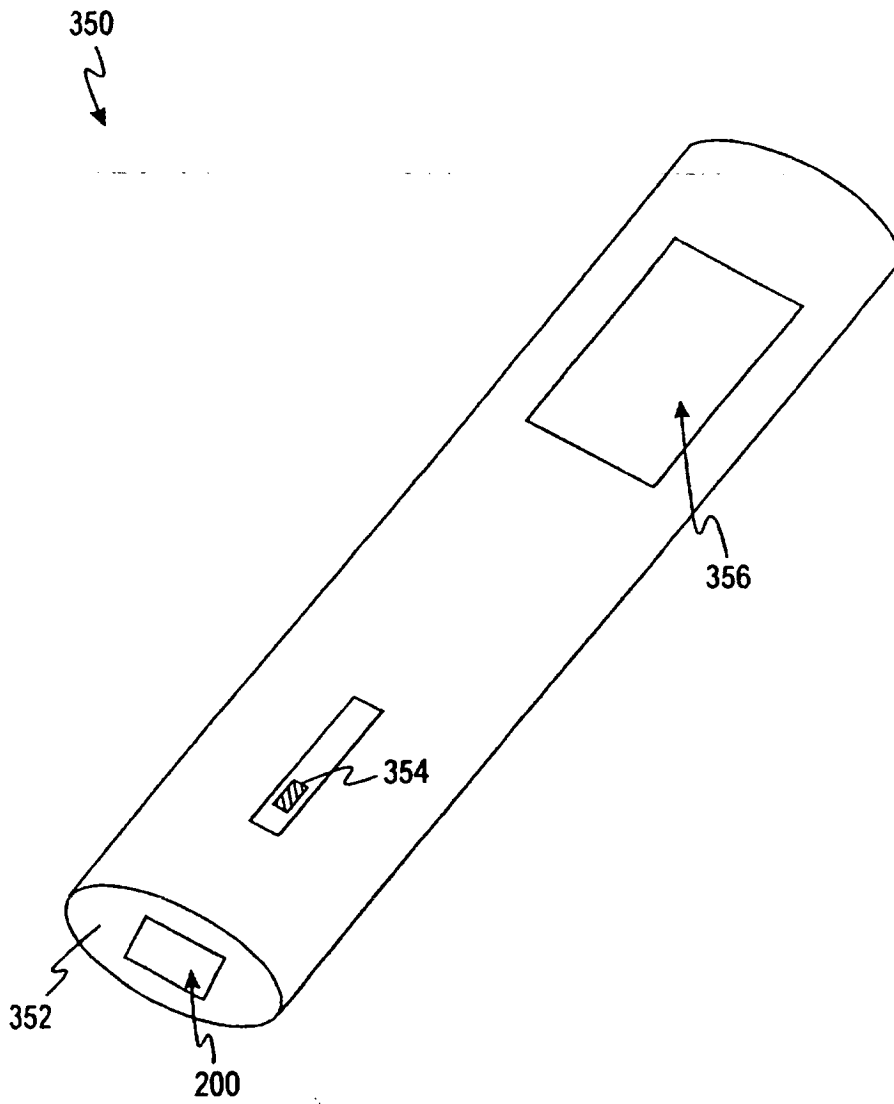

FIG. 11

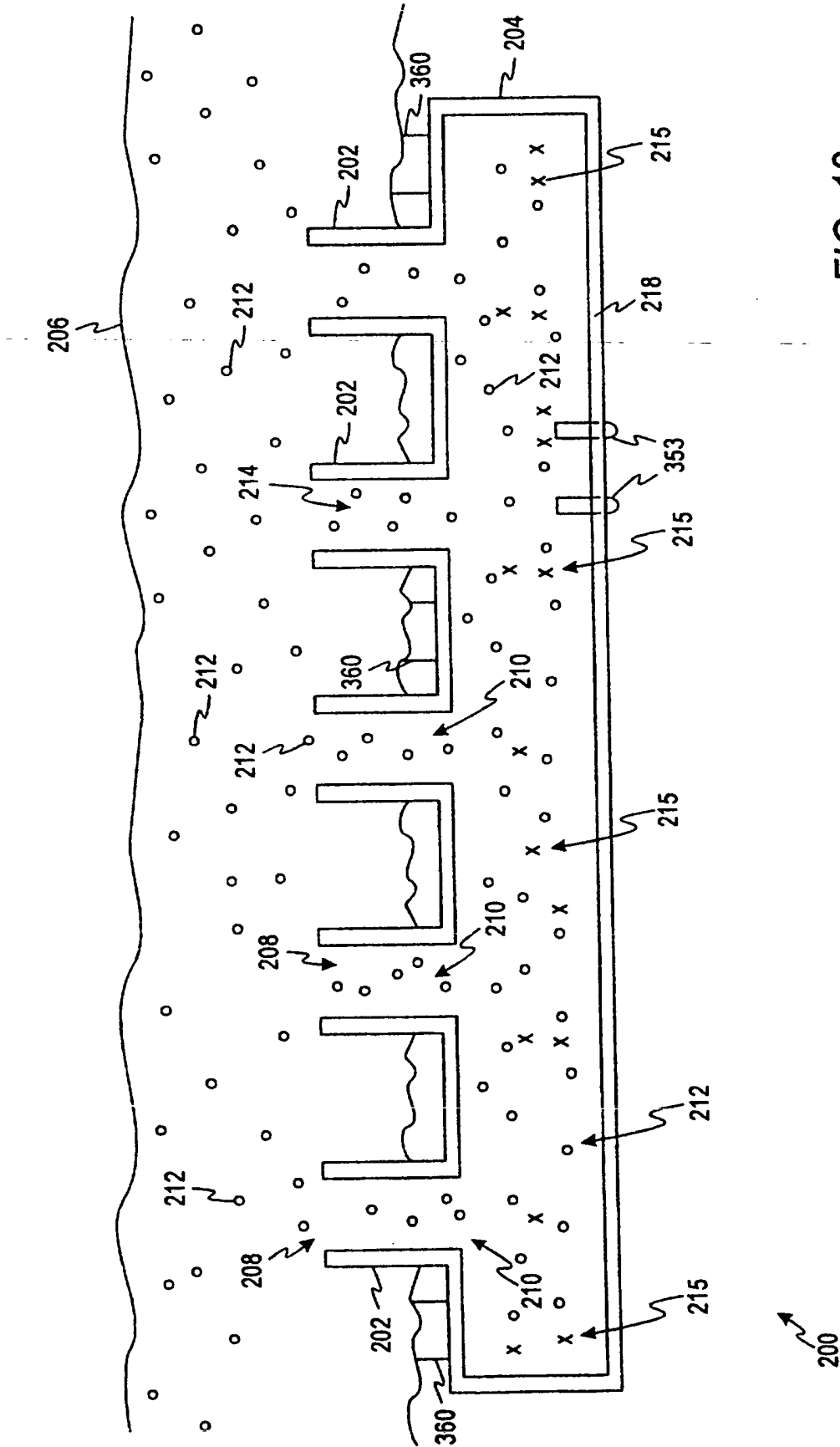

FIG. 12

专利名称(译)	中空微针贴片		
公开(公告)号	EP1174078B1	公开(公告)日	2006-11-02
申请号	EP2001115692	申请日	2001-07-05
[标]申请(专利权)人(译)	拜尔公司		
申请(专利权)人(译)	拜耳公司		
当前申请(专利权)人(译)	拜耳公司		
[标]发明人	WHITSON ROBERT C		
发明人	WHITSON, ROBERT C.		
IPC分类号	A61B5/00 A61B5/15 G01N33/483 A61M37/00 G01N21/78 G01N27/30 G01N27/416 G01N33/49 G01N33/52 G01N33/66		
CPC分类号	A61M37/0015 A61B5/14514 A61B5/14532 A61B5/150022 A61B5/150358 A61B5/150755 A61B5/150969 A61B5/150984 A61B5/15142 A61B5/15186 A61B5/157 A61M2037/0023 A61M2037/003 G01N33/528		
优先权	60/217424 2000-07-11 US		
其他公开文献	EP1174078A3 EP1174078A2		
外部链接	Espacenet		

摘要(译)

提供测试条用于测定血液中化学物质的浓度。测试条包括多个微针和测试区域。每个微针适于刺穿皮肤并抽血。测试区域与微针流体连通。测试区域包含适于产生指示血液中化学物质浓度的反应的试剂。

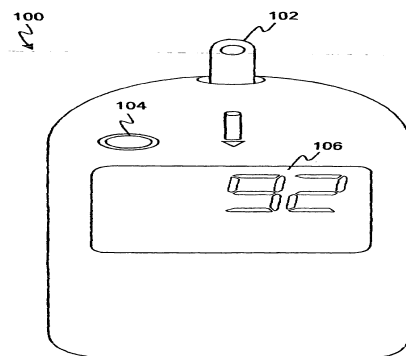

FIG. 1
(Prior Art)