



(11) **EP 3 258 841 B1**

(12) **EUROPEAN PATENT SPECIFICATION**

(45) Date of publication and mention of the grant of the patent:
10.04.2019 Bulletin 2019/15

(51) Int Cl.:
A61B 5/024 ^(2006.01) **A61B 5/1459** ^(2006.01)
A61B 5/02 ^(2006.01) **A61B 5/107** ^(2006.01)
A61B 5/00 ^(2006.01)

(21) Application number: **16707602.5**

(86) International application number:
PCT/US2016/018805

(22) Date of filing: **19.02.2016**

(87) International publication number:
WO 2016/134330 (25.08.2016 Gazette 2016/34)

(54) **SYSTEM FOR DETERMINING VESSEL SIZE AND/OR EDGE**

SYSTEM ZUR BESTIMMUNG DER GEFÄSSGRÖSSE UND/ODER -KANTE

SYSTÈME POUR DÉTERMINER LA TAILLE ET/OU LE BORD D'UN VAISSEAU

(84) Designated Contracting States:
AL AT BE BG CH CY CZ DE DK EE ES FI FR GB GR HR HU IE IS IT LI LT LU LV MC MK MT NL NO PL PT RO RS SE SI SK SM TR

- **GUNN, Jonathan**
Chicago, IL 60611 (US)
- **VIJAYVERGIA, Mayank**
Chicago, IL 60654 (US)
- **SHUKAIR, Shetha**
Chicago, IL 60640 (US)
- **LE ROLLAND, Paul**
Chicago, IL 60614 (US)

(30) Priority: **19.02.2015 US 201562118443 P**
20.02.2015 US 201562118554 P

(74) Representative: **J A Kemp**
14 South Square
Gray's Inn
London WC1R 5JJ (GB)

(43) Date of publication of application:
27.12.2017 Bulletin 2017/52

(60) Divisional application:
19158129.7

(73) Proprietor: **Briteseed, LLC**
Chicago IL 60640 (US)

(56) References cited:
EP-A1- 2 198 784 **WO-A1-2013/134411**
WO-A1-2013/134411 **US-A1- 2013 226 013**

(72) Inventors:

- **CHATURVEDI, Amal**
Chicago, IL 60640 (US)
- **SUBRAMANIAN, Hariharan**
Mundelein, IL 60060 (US)

- **K Rajbabu ET AL: "To knot or not to knot? Sutureless haemostasis compared to the surgeon's knot", Ann R Coll Surg Engl, 1 January 2007 (2007-01-01), XP055267861, DOI: 10.1308/003588407X183418**

EP 3 258 841 B1

Note: Within nine months of the publication of the mention of the grant of the European patent in the European Patent Bulletin, any person may give notice to the European Patent Office of opposition to that patent, in accordance with the Implementing Regulations. Notice of opposition shall not be deemed to have been filed until the opposition fee has been paid. (Art. 99(1) European Patent Convention).

Description

Background

5 [0001] This patent is directed to a system for determining the size and/or the edge of a vessel, such as a blood vessel, and in particular to a system using the light transmitted to a sensor array that includes a pulsating component.

[0002] Systems and methods that identify artifacts, and in particular vessels, in the surgical field during a surgical procedure provide valuable information to the surgeon or surgical team. U.S. hospitals lose billions of dollars annually in unreimbursable costs because of inadvertent vascular damage during surgery. In addition, the involved patients face a mortality rate of up to 32%, and likely will require corrective procedures and remain in the hospital for an additional nine days, resulting in tens, if not hundreds, of thousands of dollars in added costs of care. Consequently, there is this significant value to be obtained from methods and systems that permit accurate determination of the presence of vessels, such as blood vessels, in the surgical field, such that these costs may be reduced or avoided. The document WO2013134411 discloses a surgical system to determine the size of a vessel according to the preamble of independent claim 1.

[0003] Systems and methods that provide information regarding the presence of blood vessels in the surgical field are particularly important during minimally-invasive surgical procedures. Traditionally, surgeons have relied upon tactile sensation during surgical procedures both to identify blood vessels and to avoid inadvertent damage to these vessels. Because of the shift towards minimally-invasive procedures, including laparoscopic and robotic surgeries, surgeons have lost the ability to use direct visualization and the sense of touch to make determinations as to the presence of blood vessels in the surgical field. Consequently, surgeons must make the determination whether blood vessels are present in the surgical field based primarily on convention and experience. Unfortunately, anatomical irregularities frequently occur because of congenital anomalies, scarring from prior surgeries, and body habitus (e.g., obesity).

[0004] While the ability to determine the presence or absence of a vessel within the surgical field provides valuable advantages to the surgeon or surgical team and is of particular importance for minimally-invasive procedures where direct visualization and tactile methods of identification have been lost, the ability to characterize the identified vasculature provides additional important advantages. For example, it would be advantageous to provide information relating to the size of the vessel, such as the inner or outer diameter of the vessel. As another example, it would be advantageous to provide information relating to the edges of the vessel. Size information and/or edge detection is particularly relevant as the Food and Drug Administration presently approves, for example, thermal ligature devices to seal and cut vessels within a given size range, typically less than 7 mm in diameter for most thermal ligature devices. If a thermal ligature device is used to seal a larger blood vessel or only part of a vessel, then the failure rate for a seal thus formed may be as high as 19%.

[0005] In addition, it would be preferable to provide this information with minimal delay between vessel detection and vessel analysis, such that the information may be characterized as real-time. If considerable time is required for analysis, then at a minimum this delay will increase the time required to perform the procedure. In addition, the delay may increase surgeon fatigue, because the surgeon will be required to move at a deliberate pace to compensate for the delay between motion of the instrument and delivery of the information. Such delays may in fact hinder adoption of the system, even if the information provided reduces the risk of vascular injury.

[0006] Further, it would be advantageous to detect and analyze the vasculature without the need to use a contrast medium or agent. While the use of a contrast agent to identify vasculature has become conventional, the use of the agent still adds to the complexity of the procedure. The use of the agent may require additional equipment that would not otherwise be required, and increase the medical waste generated by the procedure. Further, the use of the contrast agent adds a risk of adverse reaction by the patient.

[0007] As set forth in more detail below, the present disclosure describes a surgical system including a system and method for determining vessel size and/or detecting the edges of a vessel embodying advantageous alternatives to the existing methods, which may provide for improved identification for avoidance or isolation of the vessel. The invention is set out in the appended claims.

50 Summary

[0008] According to an aspect of the present disclosure, a surgical system to determine a size of a vessel within a region proximate to a working end of a surgical instrument includes at least one light emitter disposed at the working end of the surgical instrument, and an array of light sensors disposed at the working end of the surgical instrument opposite the at least one light emitter, the array of light sensors comprising a least one row of light sensors, individual light sensors in the row of light sensors adapted to generate a signal comprising a first pulsatile component and a second non-pulsatile component. The system also includes a controller coupled to the array of light sensors, the controller comprising a splitter to separate the first pulsatile component from the second non-pulsatile component and an analyzer

to determine the magnitudes of the pulsatile and non-pulsatile components at the individual light sensors in the row of light sensors, to determine a first peak magnitude and a second peak magnitude of the pulsatile components, to determine a resting outer diameter of the vessel based on the first and second peak magnitudes of the pulsatile components.

[0009] Further disclosed herein is

a method of determining a size of a vessel within a region proximate to a working end of a surgical instrument includes emitting light at the working end of the surgical instrument, sensing light at the working end of the surgical instrument at an array of light sensors comprising at least one row of light sensors, separating a first pulsatile component from a second non-pulsatile component for individual sensors along the row of light sensors, determining the magnitudes of the pulsatile and non-pulsatile components at the individual light sensors in the row of light sensors, determining a first peak magnitude and a second peak magnitude of the pulsatile components, and determining a resting outer diameter of the vessel based on the first and second peak magnitudes of the pulsatile components.

Brief Description of the Drawings

[0010] The disclosure will be more fully understood from the following description taken in conjunction with the accompanying drawings. Some of the figures may have been simplified by the omission of selected elements for the purpose of more clearly showing other elements. Such omissions of elements in some figures are not necessarily indicative of the presence or absence of particular elements in any of the exemplary embodiments, except as may be explicitly delineated in the corresponding written description. None of the drawings is necessarily to scale.

Fig. 1 is a schematic diagram of a surgical system according to an embodiment of the present disclosure;

Fig. 2 is an enlarged, fragmentary view of the surgical instrument with light emitter and light sensors according to Fig. 1 with a section of a vessel illustrated as disposed between the light emitter and light sensors;

Fig. 3 is an enlarged cross-sectional view of a blood vessel with the wall expanding and contracting as blood flows through the vessel, with the change in outer diameter between a resting state and an expanded state exaggerated to better illustrate the changes in blood vessel outer diameter;

Fig. 4 is a flow diagram of a method which method may be carried out using the system of Fig. 1;

Fig. 5 is a flow diagram of particular actions that may be performed as part of the method illustrated in Fig. 4;

Fig. 6 is a graph of the magnitudes of the pulsatile (AC) and non-pulsatile (DC) components for each of the elements (pixels) of a light sensor array, the graph being used to illustrate general concepts disclosed herein;

Fig. 7 is a flow diagram of alternate actions that may be performed as part of the method illustrated in Fig. 4;

Fig. 8 is a graph comparing the outer diameters of various porcine arteries relative to the inner diameters of these arteries;

Fig. 9 is a flow diagram of a method which method may be carried out using the system of Fig. 1;

Fig. 10 is a flow diagram of a method which method may be carried out using the system of Fig. 1;

Fig. 11 is a simulated partial screen capture of a video monitor used in the system of Fig. 1;

Fig. 12 is a graph of the magnitudes of the pulsatile (AC) and non-pulsatile (DC) components for each of the elements (pixels) of a light sensor array (linear CCD array) used in a first set of experiments;

Fig. 13 is a graph of the magnitudes of the pulsatile (AC) and non-pulsatile (DC) components for each of the elements of a light sensor array (photodetector array, with measurements presented in pixels for comparison with Fig. 7) used in a second set of experiments;

Fig. 14 is a graph comparing the inner diameters of various porcine arteries as determined using a light sensor array (linear CCD array) and as measured in a third set of experiments;

Figs. 15 and 16 relate to a first experiment performed using systems of edge detection according to an embodiment of the present disclosure;

Figs. 17 and 18 relate to a second experiment performed using systems of edge detection according to an embodiment of the present disclosure;

Figs. 19 and 20 relate to a third experiment performed using systems of edge detection according to an embodiment of the present disclosure; and

Figs. 21 and 22 relate to a fourth experiment performed using systems of edge detection according to an embodiment of the present disclosure

Detailed Description of Various Embodiments

[0011] A surgical system according to an embodiment of the present disclosure includes at least one light emitter, at least one light sensor, and a controller. The system may also include a surgical instrument as well.

[0012] The system determines a size and/or an edge or edges of a vessel within a region proximate to a working end of the surgical instrument. In particular, it is believed that the system may be used to determine the size and/or edges

of a vessel within the region proximate to the working end of the surgical instrument regardless of the presence or the type of tissue surrounding the vessel. The embodiments of the system described below perform determinations relative to the presence and size of the vessel within the targeted region based on the light transmittance as determined by the light sensor, and thus the embodiments may appear facially similar to the technology used in transmissive pulse oximetry to determine the oxygen saturation (*i.e.*, the percentage of blood hemoglobin that is loaded with oxygen). Careful consideration of the following disclosure will reveal that the disclosed system utilizes the light emitter(s) and light sensor(s) in conjunction with a controller (either in the form of unique circuitry or a uniquely programmed processor) to provide information regarding the presence and size of vessels that would not be provided by a pulse oximeter. Further, the disclosed embodiments include the use of a sensor array, the controller processing the pulsatile and non-pulsatile components of signals from that array to yield information regarding the diameter(s) of the vessel (e.g. the inner diameter or the resting outer diameter). Moreover, the disclosed technology may be utilized with vessels other than blood vessels, further separating the disclosed system and method from a transmissive pulse oximeter.

[0013] Figs. 1 and 2 illustrate an embodiment of such a surgical system 100 used to determine a size (e.g., diameter) and/or an edge or edges of a vessel, V, within a region 102 of tissue, T, proximate to a working end 104 of a surgical instrument 106. It will be understood that the vessel V may be connected to other vessels with the region 102 of tissue T, and in addition, the vessel V may extend beyond the region 102 so as to be in fluid communication with other organs (e.g., the heart) also found in the body of the patient. Furthermore, while the tissue T appears in Figs. 1 and 2 to surround fully the vessel V (in terms of both circumference and length) to a particular depth, this need not be the case in all instances where the system 100 is used. For example, the tissue T may only partially surround the circumference of and/or only surround a section of the length of the vessel V, or the tissue T may overlie the vessel V in a very thin layer. As further non-limiting examples, the vessel V may be a blood vessel, and the tissue T may be connective tissue, adipose tissue or liver tissue.

[0014] The surgical system 100 includes at least one light emitter 110 (or simply the light emitter 110), at least one light sensor or detector 112 (or simply the light sensor 112), and a controller 114 coupled to the light emitter 110 and the light sensor 112. As noted above, the system 100 also may include the surgical instrument 106.

[0015] The light emitter 110 is disposed at the working end 104 of the surgical instrument 106. The light sensor 112 is also disposed at the working end 104 of the surgical instrument 106. As illustrated in Figs. 1 and 2, the light sensor 112 may be disposed opposite the light emitter 110 because the light emitter 110 and the light sensor 112 are disposed on opposing elements of the surgical instrument 106, as explained in detail below.

[0016] The light emitter 110 is adapted to emit light of at least one wavelength. For example, the light emitter 110 may emit light having a wavelength of 660 nm. This may be achieved with a single element, or a plurality of elements (which elements may be arranged or configured into an array, for example, as explained in detail below). In a similar fashion, the light sensor 112 is adapted to detect light at the at least one wavelength (e.g., 660 nm). According to the embodiments described herein, the light sensor 112 includes a plurality of elements, which elements are arranged or configured into an array.

[0017] According to certain embodiments, the light emitter 110 may be configured to emit light of at least two different wavelengths, and the light sensor 112 may be configured to detect light at the at least two different wavelengths. For example, the light emitter 110 may emit light of three wavelengths, while the light sensor may detect light of three wavelengths. As one example, the light emitter 110 may emit and the light sensor 112 may detect light in the visible range, light in the near-infrared range, and light in the infrared range. Specifically, the light emitter 110 may emit and the light sensor 112 may detect light at 660 nm, at 810 nm, and at 940 nm. Such an embodiment may be used, for example, to ensure optimal penetration of blood vessel V and the surrounding tissue T under *in vivo* conditions.

[0018] In particular, the light emitted at 810 nm may be used as a reference to remove any variations in the light output because of motion and/or blood perfusion. The 810 nm wavelength corresponds to the isobestic point, where the absorption for both oxygenated and deoxygenated hemoglobin is equal. Consequently, the absorption at this wavelength is independent of blood oxygenation and is only affected by the change in light transmittance because of motion and/or changes in perfusion.

[0019] As stated above, the light sensor may be in the form of an array of light sensors. In fact, the array of light sensors 112 further includes at least one row of light sensors (see Fig. 2); according to certain embodiments, the array 112 may include only a single row of light sensors, and the array 112 may be referred to in the alternative as a linear array. The at least one row of light sensors 112 includes a plurality of individual light sensors. The individual light sensors 112 may be disposed adjacent each other, or the light sensors may be spaced from each other. It may even be possible for the individual light sensors that define a row of light sensors to be separated from each other by light sensors that define a different row or column of the array. According to a particular embodiment, however, the array may comprise a charge coupled device (CCD), and in particular linear CCD imaging device comprising a plurality of pixels.

[0020] According to the embodiments of this disclosure, the individual light sensors 112 (e.g., pixels) are adapted to generate a signal comprising a first pulsatile component and a second non-pulsatile component. It will be recognized that the first pulsatile component may be an alternating current (AC) component of the signal, while the second non-

pulsatile component may be a direct current (DC) component. Where the light sensor 112 is in the form of an array, such as a CCD array, the pulsatile and non-pulsatile information may be generated for each element of the array, or at least for each element of the array that defines the at least one row of the array.

5 **[0021]** As to the pulsatile component, it will be recognized that a blood vessel may be described as having a characteristic pulsation of approximately 60 pulses (or beats) per minute. While this may vary with the patient's age and condition, the range of pulsation is typically between 60 and 100 pulses (or beats) per minute. The light sensor 112 will produce a signal (that is passed to the controller 114) with a particular AC waveform that corresponds to the movement of the blood through the vessel. In particular, the AC waveform corresponds to the light absorption by the pulsatile blood flow within the vessel. On the other hand, the DC component corresponds principally to light absorption and scattering by
10 the surrounding tissues.

[0022] In particular, it is believed that the elements of the light sensor array 112 disposed on the opposite side of the vessel V from the light emitter 110 will have a higher AC signal than those elements where the vessel V is not disposed between the light emitter 110 and the light sensor array 112, because the most marked fluctuations in the transmitted light will be caused by the vessel-associated pulsations. It is also believed that the elements of the array 112 disposed
15 on the opposite side of the vessel V from the light emitter 110 will have a decreased DC signal compared to elements of the array 112 where the vessel V is not disposed between the light emitter 110 and the array 112.

[0023] In fact, it is believed that particular regions of vessels, such as blood vessels, may undergo more pronounced pulsations than other regions, which differences are reflected in differences in the pulsatile component of the signal received from the array 112. More particularly and with reference to blood vessels as a non-limiting example, as the heart pumps blood through the body, the muscular arteries pulse to accommodate the volume of blood being directed through the body. As this occurs, the middle layer (or tunica media) of the vessel expands and contracts. The expansion and contraction of the tunica media results in a relatively more significant change to the outer diameter of the vessel than to the inner diameter of the vessel. It is believed that the relatively more significant change in outer diameter that occurs during the expansion and contraction of the vessel causes the greatest fluctuations in the AC signal (which, as
20 mentioned above, is related to the pulsations) over time at the edges of the vessel, as the outer diameter oscillates between an expanded position A and a resting position B (see Fig. 3).

[0024] Thus, according to the disclosed embodiments, the controller 114 is coupled to the light sensor 112, and includes a splitter 116 to separate the first pulsatile component from the second non-pulsatile component for each element of the light sensor array 112. The controller 114 also includes an analyzer 118 to quantify the size of the vessel V within the
25 region 102 proximate to the working end 104 of the surgical instrument 106 based on the pulsatile component. To display, indicate or otherwise convey the size of the vessel V within the region 102, the controller 114 may be coupled to an output device or indicator 130 (see Fig. 1), which may provide a visible, audible, tactile or other signal to the user of the instrument 106.

[0025] In particular, the analyzer 118 may determine the magnitudes of the pulsatile components at the individual light sensors in the row of light sensors. Further, the analyzer may determine a first peak magnitude and a second peak magnitude of the pulsatile components. The analyzer may make the determination as to the first and second peak magnitudes after first determining the locations of transitions in the pulsatile and non-pulsatile components of the signal between higher and lower magnitudes, as explained in detail below. In addition, the analyzer 118 may determine a resting outer diameter of the vessel V based on the first and second peak magnitudes of the pulsatile components.
35

[0026] According to certain embodiments, the analyzer 118 may determine the resting outer diameter of the vessel V by determining a first pair of positions along the row of light sensors where the magnitudes of the pulsatile component are a percentage (e.g., between 25% and 75%, such as 50%) of the first (or second) peak magnitude, and a second pair of positions along the row of light sensors where the magnitudes of the pulsatile component are also the same percentage of the first (or second) peak magnitude, the second pair being disposed between the first pair of positions along the row of light sensors. The analyzer then determines a first distance between the first pair of positions and a second distance between the second pair of positions, and determines the resting outer diameter of the vessel as the average of the first and second distances. According to other embodiments, the analyzer 118 may instead use the inner pair of positions and a relationship between the inner and resting outer diameters. According to certain embodiments, the non-pulsatile component may be used instead of the pulsatile component.
40

[0027] According to certain embodiments, the splitter 116 and the analyzer 118 may be defined by one or more electrical circuit components. According to other embodiments, one or more processors (or simply, the processor) may be programmed to perform the actions of the splitter 116 and the analyzer 118. According to still further embodiments, the splitter 116 and the analyzer 118 may be defined in part by electrical circuit components and in part by a processor programmed to perform the actions of the splitter 116 and the analyzer 118.
45

[0028] For example, the splitter 116 may include or be defined by the processor programmed to separate the first pulsatile component from the second non-pulsatile component. Further, the analyzer 118 may include or be defined by the processor programmed to quantify the size of the vessel V within the region 102 proximate to the working end 104 of the surgical instrument 106 based on the first pulsatile component. The instructions by which the processor is pro-
50

grammed may be stored on a memory associated with the processor, which memory may include one or more tangible non-transitory computer readable memories, having computer executable instructions stored thereon, which when executed by the processor, may cause the one or more processors to carry out one or more actions.

5 [0029] In addition to the system 100, the present disclosure includes a method 200 of determining if a size of a vessel V within a region 102 proximate to a working end 104 of a surgical instrument 106. The method 200 may be carried out, for example, using a system 100 as described above in regard to Fig. 1. As illustrated in Fig. 4, the method 200 of operating the system 100 includes emitting light at a working end of a surgical instrument at block 202 and sensing light at the working end of the surgical instrument at an array of light sensors comprising at least one row of light sensors at block 204. As explained above, the light emitted may include light of at least two different wavelengths, and the sensing step may thus include sensing light of at least two different wavelengths. As also noted above, three different wavelengths of light may be used, and for example in the visible range and the near-infrared range. According to one embodiment, the light used may have wavelengths of 660 nm, 810 nm, and 940 nm.

10 [0030] The method 200 continues at block 206 wherein a pulsatile component is separated from a non-pulsatile component for individual sensors along the row of light sensors. The method 200 also includes determining the magnitudes of the pulsatile components at the individual light sensors in the row of light sensors at block 208, determining a first peak magnitude and second peak magnitude of the pulsatile components at block 210, and determining a resting outer diameter of the vessel based on the first and second peak magnitudes of the pulsatile components at block 212.

15 [0031] More particular, as illustrated in Fig. 5, the block 212 of the method 200 of Fig. 4 may include one or more actions. In particular, as illustrated in Fig. 5, the action of block 212 may include determining a first pair and a second pair of positions along the row of light sensors at block 212-1, where the magnitudes of the pulsatile component of the first and second pair of positions are a percentage of the first (or second) peak magnitude. The second pair of positions is disposed between the first pair of positions, as will be discussed relative to Fig. 6 below. In addition, the action of block 212 may include determining a first distance between the first pair of positions and a second distance between the second pair of positions at block 212-2, and determining the resting outer diameter of the vessel V as the average of the first and second distances at block 212-3.

20 [0032] To illustrate further the method 200 of operation of the system 100, as illustrated in Figs. 4 and 5, a plot is provided in Fig. 6. In particular, Fig. 6 is a simulated plot of the magnitude of the pulsatile (AC) component for each element of a light sensor array and a plot of the magnitude of the non-pulsatile (DC) component for the same elements of the array. The lines are marked AC and DC to differentiate the two plots. According to this simulation, a vessel (specifically, a blood vessel) is disposed between the light sensor array and a light emitter array, with the vessel located generally between the light emitter array and the light sensor array in the region between 40 and 180 pixels.

25 [0033] As illustrated in Fig. 6, the DC signal plot decreases from a relatively high value to a considerably lower value, and then increases from the lower value back to higher value at two different points (i.e., at points 300, 302) along the sensor array 112. In accordance with the observations made above, the decrease in the magnitude of the DC signal in the region would be expected to occur where the vessel is disposed between the light emitter 110 and the light sensor 112, and it therefore may be inferred that the vessel V is disposed between the point at which the DC signal plot transitions from the higher value to the lower value (i.e., point 300) and the point at which the DC signal plot transitions from the lower value back to the higher value (i.e., point 302).

30 [0034] In addition, the AC signal increases significantly from a relatively low value to a higher value at the point (i.e., point 304) on one side of where the vessel is presumably located, and from a high value to a lower value (i.e., point 306) on the other side of where the vessel is located. As also mentioned above, the relative increase in pulsatile (AC) signal is believed to occur where the vessel is disposed between the light emitter 110 and the light sensor 112, and it therefore may be inferred that the vessel V is disposed between the point at which the AC signal plot transitions from the lower value to the higher value (i.e., point 304) and the point at which the AC signal plot transitions from the higher value back to the lower value (i.e., point 306).

35 [0035] While either the change in the DC signal or the change in the AC signal may be used to define a region of interest (ROI), the combination of the information on the transitions in the AC signal may be combined with the transitions in the DC signal to define an ROI to which the further consideration of the pulsatile (AC) information is confined. That is, the system 100 (and more particularly the controller 120) may consider a subset of elements of all of the elements of the sensor array 112 in accordance with this information. This may be particularly helpful in eliminating fluctuations unrelated to the vessel in individual sensors along the array. According to such embodiments, the transitions between higher and lower values for each of the DC and AC plots are determined, and only the ROI where there is overlap between decreased DC magnitude and increased AC magnitude is considered. As illustrated in Fig. 6, this region would be between the vertical bars (i.e., from about 40 pixels to 180 pixels).

40 [0036] According to the present disclosure, as illustrated in Figs. 4 and 5, the resting diameter of the vessel may be calculated based on a correlation observed between the expanded outer diameter of the vessel and the inner diameter of the vessel. In particular, it has been observed that the resting diameter of the vessel correlates to the average of the expanded outer diameter of the vessel and the inner diameter of the vessel. To perform this calculation, the expanded

outer diameter (or line A) of the vessel is determined to be the distance between a first pair of points at which the AC magnitude is approximately 50% of the peak AC magnitude: the leftmost occurrence (i.e., point 312) prior to (or leading) the leftmost AC peak magnitude (i.e., at point 308) and the rightmost occurrence (i.e., point 314) after (or lagging) the rightmost AC peak magnitude (i.e., at point 310). In addition, the inner diameter (or line C) is determined to be the distance between a second pair of points at which the AC magnitude is approximately 50% of the peak AC magnitude: the leftmost occurrence (i.e., point 316) after (or lagging) the leftmost AC peak magnitude (i.e., at point 308) and the rightmost occurrence (i.e., point 318) prior to (or leading) the rightmost AC peak magnitude (i.e., at point 310). These distances may also be described as the distances between the two occurrences of 50% peak AC magnitude outside and inside the peak AC magnitudes. It may also be said that the second pair is disposed between or inside the first pair.

[0037] It is not necessary to use the occurrences at 50% peak AC magnitude according to all embodiments of the present disclosure. According to other embodiments, the inner diameter may be determined to be distance between the leftmost occurrence after (or lagging) the leftmost AC peak magnitude and the rightmost occurrence prior to (or leading) the rightmost AC peak magnitude of 5% peak AC magnitude, while the expanded outer diameter also was determined at the 5% peak AC magnitude occurrences described above.

[0038] Finally, as illustrated in Fig. 6, the resting outer diameter (line B) may be determined to be the average between the inner diameter (line C) and the expanded outer diameter (line A).

[0039] According to the present disclosure, the determination of the resting outer diameter of the vessel V may be calculated without reference to two pairs of positions along the row of light sensors. More particular, the actions performed by the system 100 at the block 212 of the method 200 of Fig. 4 to determine the resting outer diameter of the vessel V may be as illustrated in Fig. 7. According to this alternate method, the action of block 212 may include determining a pair of positions along the row of light sensors at block 212-1' in between the two positions where the peak magnitudes occur. The single pair of positions (or "inner" pair) may occur where the magnitudes of the pulsatile component are a percentage of the first (or second) peak magnitude. For example, the inner pair may be defined by the pair of positions between the positions where the peak magnitudes occur corresponding to 50% of the first (or second) peak magnitude.

In addition, the action of block 212 may include determining a distance between the inner pair at block 212-2'.

[0040] At block 212-3', the distance between the inner pair of positions is then used to calculate the resting outer diameter. According to this method, as was the case in the method of Fig. 5, the distance between the inner pair of positions is representative of the inner diameter of the vessel V. Further, it is believed that the inner diameter of a vessel undergoing expansion and contraction varies to a far lesser degree (if at all) than the outer diameter. Moreover, it has been observed that the signal from the edges of the vessel may be obscured by the presence of tissue disposed about the vessel. Consequently, rather than attempting to approximate the outer diameter of the vessel, a relationship may be determined empirically between the inner diameter and resting outer diameter, which relationship may be used to calculate the resting outer diameter based on the measurement of the inner diameter, as determined in accordance with the actions of blocks 212-1' and 212-2'.

[0041] In its simplest form, the resting outer diameter may be determined to be a multiple of the inner diameter. According to other embodiments, the resting outer diameter may be calculated to be a multiple of the inner diameter with the addition of a constant term. Fig. 8 is a graph comparing the inner diameters and resting outer diameters of a set of muscular arteries. Based on this graph, a formula relating the outer diameter (y) with the inner diameter (x) was determined ($y = 1.2x + 0.9$). Accordingly, for a given inner diameter determined at blocks 212-1' and 212-2', the formula may be used to calculate the resting outer diameter at block 212-3'.

[0042] A further method that may be practiced using, for example, the system 100 illustrated in Fig. 1 is illustrated in Fig. 9. The method 220 illustrated in Fig. 9 addresses a complication that may occur if the vessel is grasped tightly between the jaws of an instrument, such as is illustrated in Figs. 1 and 2. In particular, the compression of the vessel V between the jaws of the surgical instrument 106 may change the pulsatile component of the signal, such that only a single peak may be observed, instead of the two peaks as illustrated in Fig. 6.

[0043] The method 220 is similar to the method 200 in that light is emitted from the light emitter 110 at block 222, and the transmitted light is sensed or detected by the light sensor array 112 at block 224. The system 100 (or more particularly the controller 114) operates to separate the non-pulsatile component of the signal from the pulsatile component of the signal at block 226, and determines the magnitude of the pulsatile component at the individual sensors at block 228.

[0044] At block 230, the system 100 (controller 114) then makes a determination as to the number of positions identified with a peak pulsatile magnitude at block 230. According to certain embodiments, this determination may be performed after a region of interest is identified using transitions in the non-pulsatile component (e.g., from a higher magnitude to a lower magnitude) and optionally in the pulsatile component (e.g., from a lower magnitude to a higher magnitude). In fact, according to some embodiments, the determination at block 230 is performed once the transition in the non-pulsatile component of the signal from a higher magnitude to a lower magnitude is identified.

[0045] If the determination is made at block 230 that two peaks are present, for example, then the method 220 may proceed to blocks 232, 234, 236, where a method similar to that described in regard to Fig. 7 is performed (although it will be appreciated that a method similar to that described in regard to Fig. 5 may be substituted). If the determination

is made at block 230 that a single peak is present, then the method 220 may proceed to blocks 242, 244, 246. In particular, a determination is made at block 242 as to a single pair of positions along the row of light sensors where the magnitudes of the pulsatile component are a percentage of the peak magnitude. For example, the pair may be defined by the pair of positions on either side of the peak magnitude (i.e., to the left or the right of the position corresponding to the peak magnitude) where the magnitude corresponds to 50% of the peak magnitude. In addition, the system 100 (controller 114) may determine the distance between this pair of positions at block 244. The system 100 may then use the distance determined as the value for the inner diameter, and calculate the resting outer diameter using the relationship established between inner diameter and outer diameter, in a process similar to that described in regard to block 212-3' in Fig. 7.

[0046] It will be recognized that while the method 220 was described with reference to a determination as to how many peaks are present, the specifics as to how this determination is performed may differ among the various embodiments. For example, the determination may be made according to whether one peak is or two peaks are present. Alternatively, the determination may be made according to whether a single peak is present, with subsequent actions taken dependent upon whether the answer to this question is yes or no.

[0047] A further alternative to the methods described in Figs. 4-9 is to use the non-pulsatile component of the signal to determine the vessel outer diameter. As illustrated in Fig. 10, the method 250 starts much like the methods 200, 220, in that light is emitted at block 252, transmitted light is sensed or detected at block 254, and pulsatile and non-pulsatile components are separated at block 256. Unlike the methods above, the system 100 (controller 114) interrogates the non-pulsatile component at block 258 to determine the non-pulsatile magnitude at individual sensors at block 258. Moreover, unlike the methods above, the system 100 determines the positions along the row of light sensors where the non-pulsatile magnitude transitions from a higher value to a lower value and where the non-pulsatile magnitude transitions from a lower value back to a higher value at block 260. This pair of positions, based on these transitions in the non-pulsatile component of the signal, is then used to determine the resting outer diameter at block 262. For example, the distance between the pair of positions may be used as the estimate for the resting outer diameter, or a relationship based on empirical data may be used to calculate the resting outer diameter according to the distance between the pair of positions where the non-pulsatile component transitions.

[0048] According to certain embodiments, a system for determining the edge of a vessel may be provided in conjunction with the foregoing. It will be recognized, however, that the system and method of edge determination may also be used separately from the foregoing systems and methods, although the system and method may utilize the same hardware in terms of the light emitters 110, light sensors 112, and so on. According to such embodiments, the controller 114 would include an analyzer 118 to quantify the edges of the vessel V within the region 102 proximate to the working end 104 of the surgical instrument 106 based on the signals received from the array 112. To display, indicate or otherwise convey the edges of the vessel V within the region 102, the controller 114 may be coupled to an output device or indicator 130 (see Fig. 1), which may provide a visible, audible, tactile or other signal to the user of the instrument 106.

[0049] In particular, the analyzer 118 may determine the magnitudes of the pulsatile (AC) and non-pulsatile (DC) components at the individual light sensors in the row of light sensors. In fact, the analyzer 118 may focus on the sensors at the distalmost edge of the instrument, i.e., the edge closest to the patient. Where the instrument 106 has a pair of jaws, this would be sensor(s) closest to the opening of the jaws. If the sensor senses a significant decrease in the DC magnitude and a significant increase in the AC magnitude, the analyzer 118 may interpret this event as signifying that the jaws, and more specifically the sensors at the distalmost edge of the jaws, have encountered something (tissue, blood vessel, etc.). Under the circumstances, the analyzer 118 may use one of the afore-mentioned indicators 130 to alert the user.

[0050] It was recognized, however, that because the jaws of the surgical instrument 106 are in the open space in the beginning of the procedure, regardless of the type of material that is moved between the jaws, the analyzer 118 will determine a decrease in the DC component magnitude and a corresponding increase in the AC component magnitude. As such, the user may receive an alert, but would not know if the alert was because of the presence of a tissue, or of a vessel.

[0051] If, however, the analyzer 118 is determining the DC and AC magnitudes using a recursive calculation, then there are new DC and AC magnitudes calculated with each incoming sample (data point). In such a circumstance, the analyzer 118 may be configured such that when the analyzer 118 determines that a change has occurred in the DC and AC magnitudes, the analyzer 118 collects data on a plurality of successive AC magnitudes. If the jaws of the instrument 106 have tissue between them, then light intensity absorbed may vary only to a small degree and the magnitudes should not change much. Because the AC magnitude is proportional to the change in the observed values, it will also experience a small increase in value with the following incoming samples. If there is a blood vessel, or more particularly an edge of a blood vessel, at the distalmost edge of the jaws, then the magnitudes will change in a sinusoidal fashion and the AC magnitudes should see a drastic change with the next incoming sample (data point).

[0052] In particular, the analyzer 118 may be configured to carry out an edge determination in keeping with the following relations or equations. In these relations or equations, the light intensity received by a sensor at the distalmost end of the jaw at time instant t is $I(t)$. According to the Beer's Law (Eqn. 1):

$$I(t) = I_0 e^{-\alpha(t)L}$$

where $\alpha(t)$ (being a function of time) is the absorption coefficient of the material and L is the thickness of the material. The recursive variance (the square of AC RMS) is computed using the following equation (Eqn. 2):

$$v(t) = \frac{t-1}{t} v(t-1) + \frac{1}{t} [I(t) - I(t-1)]^2 + \frac{t-1}{t^2} [I(t-1) - I(t)]^2$$

where $I(t)$ and $I(t-1)$ denote the mean computed at time instants t and $t-1$, respectively. If the material is a tissue, $\alpha(t) = \alpha$ which implies $I(t) \approx I(t-1)$ which further signifies $I(t) \approx I(t-1)$. Evaluating these relations results in the following (Eqn. 3):

$$[I(t) - I(t-1)] \approx [I(t-1) - I(t)] \approx 0$$

[0053] Combining Eqns. (2) and (3), results in the following (Eqn. 4):

$$v(t) = \frac{t-1}{t} v(t-1)$$

$$\Rightarrow v(t) \approx v(t-1) \text{ given the sampling period, } t-1 \approx t$$

[0054] In accordance with Eqn. 4, the variance or the AC RMS for tissue will almost remain a constant over time. However, this will not be the case when a blood vessel is between the jaws ($\alpha(t) \neq \alpha$). For a blood vessel, the signal would be sinusoidal and the variance/AC RMS will increase sharply before saturating at its actual value (around one time period). So looking at the values of $v(t)$ $1 \leq t \leq u$ where $2 \leq u \leq T$ with T being the time period of the signal or the heart rate.

[0055] This differentiating nature of these relations may further be accentuated through the inclusion of a contrast enhancing factor. In particular, the DC magnitudes may be used as the contrast enhancing factor. Specifically, it is believed that inspection of the changes in the AC and DC magnitudes at the same time may add contrast between the tissue and the blood vessel. The larger the DC magnitude, the greater the probability of nothing (tissue or vessel) being present between the jaws. To implement the DC magnitude as a contrast enhancing factor, rather than making the edge determination based only on the change in the AC magnitude, the analyzer 118 may make the edge determination based on the ratio of AC/DC over time.

[0056] Thus, the analyzer 118 may be configured to determine the presence of an edge of a vessel according to the following method. First, the analyzer 118 determines if there has been a significant change in the DC and the AC; if there has not been a significant change, then the analyzer 118 determines that there nothing is present between the jaws or at the distalmost end or edge of the surgical instrument 106. If the DC ($I(0)$) and the AC ($v(0)$) values of the sensor at the end or edge of the jaws change, then the analyzer 118 determines that something (e.g., tissue, vessel) has been detected. The analyzer 118 then checks the ratio:

$$r = \frac{1}{u} \sum_{t=1}^u \left[\frac{v(t)}{I(t)} \right]$$

[0057] The ratio may then be compared to a threshold to differentiate between tissue and a blood vessel.

[0058] This method also may be used to eliminate the tissue artifact. Based on the ratio, the method may eliminate the DC decrease caused by the tissue and the corresponding AC peaks. This could improve a size (diameter) determination of the vessel and make size determination more robust.

[0059] Having thus described the surgical system 100, the method 200 and the principles of the system 100 and the method 200 in general terms, further details of the system 100 and its operation are provided.

[0060] Initially, while the emitter 110 and the sensor 112 are described as disposed at the working end 104 of the surgical instrument 106, it will be recognized that not all of the components that define the emitter 110 and the sensor 112 need be disposed at the working end of the instrument 106. That is, the emitter 110 may comprise a light emitting

diode, and that component may be disposed at the working end 104. Alternatively, the emitter 110 may include a length of optical fiber and a light source, the source disposed remotely from the working end 104 and the fiber having a first end optically coupled to the source and a second end disposed at the working end 104 facing the sensor 112. According to the present disclosure, such an emitter 110 would still be described as disposed at the working end 104 because the light is emitted into the tissue at the working end 104 of the instrument 106. A similar arrangement may be described for the sensor 112 wherein an optical fiber has a first end disposed facing the emitter 110 (or perhaps more particularly, an end of the optical fiber that in part defines the emitter 110) and a second end optically coupled to other components that collectively define the sensor 112.

[0061] As also mentioned above, the light emitter 110 and light sensor 112 are positioned opposite each other. This does not require the emitter 110 and the sensor 112 to be directly facing each other, although this is preferred. According to certain embodiments, the emitter 110 and sensor 112 may be formed integrally (i.e., as one piece) with jaws 180 of a surgical instrument 106. See Figs. 1 and 2. In this manner, light emitted by the emitter 110 between the jaws 180 and through the tissue of interest may be captured by the light sensor 112.

[0062] The light emitter 110 may include one or more elements. According to an embodiment schematically illustrated in Fig. 2, the light sensor 112 may include a first light emitter 110-1, a second light emitter 110-2, and a third light emitter 110-3. All of the light emitters may be adapted to emit light at a particular wavelength (e.g., 660 nm), or certain emitters may emit light at different wavelengths than other emitters.

[0063] As to those embodiments wherein the light emitter 110 is in the form of an array including one or more light emitting diodes, as is illustrated in Fig. 2 for example, the diodes may be arranged in the form of a one-dimensional, two-dimensional or three-dimensional array. An example of a one-dimensional array may include disposing the diodes along a line in a single plane, while an example of a two-dimensional array may include disposing the diodes in a plurality of rows and columns in a single plane. Further example of a two-dimensional array may include disposing the diodes along a line on or in a curved surface. A three-dimensional array may include diodes disposed in more than one plane, such as in a plurality of rows and columns on or in a curved surface.

[0064] The light sensor 112 according to the embodiments of the present disclosure also includes one or more individual elements. According to an embodiment illustrated in Fig. 2, the light sensor 112 may include a first light sensor 112-1, a second light sensor 112-2, an n-th light sensor 112-n, and so on. As was the case with the light emitters 110-1, 110-2, 110-3, the light sensors 112-1, 112-2, 112-3 may be arranged in an array, and the discussion in regard to the arrays above applied with equal force here.

[0065] As discussed above, the system 100 may include hardware and software in addition to the emitter 110, sensor 112, and controller 114. For example, where more than one emitter 110 is used, a drive controller may be provided to control the switching of the individual emitter elements. In a similar fashion, a multiplexer may be provided where more than one sensor 112 is included, which multiplexer may be coupled to the sensors 112 and to an amplifier. Further, the controller 114 may include filters and analog-to-digital conversion as may be required.

[0066] As for the indicator 130 used in conjunction with controller 114, a variety of output devices may be used. As illustrated in Fig. 1, a light emitting diode 130-1 may be attached to or incorporated into the associated surgical instrument 106, and may even be disposed at the working end 104 of the instrument 106. Alternatively or in addition, an alert may be displayed on a video monitor 130-2 being used for the surgery, or may cause an image on the monitor to change color or to flash, change size or otherwise change appearance. For example, Fig. 11 illustrates a portion of a graphical user interface (GUI) that may be displayed on the video monitor 130-2, wherein a first region 132 is representative of the location of a section of a vessel and surrounding tissue between the jaws of the surgical instrument 106 and a second region 134 is an enhanced representation of the section of vessel and surrounding tissue illustrated in first region 132 with the vessel represented in a contrasting fashion to the surrounding tissue (e.g., through the use of bands of different color for the vessel and the surrounding tissue). The indicator 130 may also be in the form of or include a speaker 130-3 that provides an auditory alarm. The indicator 130 also may be in the form of or may incorporate a safety lockout 130-4 associated with the surgical instrument 106 that interrupts use of the instrument 106. For example, the lockout could prevent ligation or cauterization where the surgical instrument 106 is a thermal ligature device. As a still further example, the indicator 130 also may be in the form of a haptic feedback system, such as a vibrator 130-5, which may be attached to or formed integral with a handle or handpiece of the surgical instrument 106 to provide a tactile indication or alarm. Various combinations of these particular forms of the indicator 130 may also be used.

[0067] As mentioned above, the surgical system 100 may also include the surgical instrument 106 with the working end 104, to which the light emitter 110 and light sensor 112 are attached (in the alternative, removably/reversibly or permanently/irreversibly). The light emitter 110 and the light sensor 112 may instead be formed integrally (i.e., as one piece) with the surgical instrument 106. It is further possible that the light emitter and light sensor be attached to a separate instrument or tool that is used in conjunction with the surgical instrument or tool 106.

[0068] As noted above, the surgical instrument 106 may be a thermal ligature device in one embodiment. In another embodiment, the surgical instrument 106 may simply be a grasper or grasping forceps having opposing jaws. According to still further embodiments, the surgical instrument may be other surgical instruments such as dissectors, surgical

staplers, clip applicators, and robotic surgical systems, for example. According to still other embodiments, the surgical instrument may have no other function than to carry the light emitters/light sensors and to place them within a surgical field. The illustration of a single embodiment is not intended to preclude the use of the system 100 with other surgical instruments or tools 106.

Examples

[0069] Experiments have been conducted using an embodiment of the above-described system. The experiments and results are reported below.

[0070] The first set of experiments was conducted using an excised porcine carotid artery. To simulate the pulsatile flow of fluid found in such blood vessels, a submersible DC pump was used. The pump was capable of operation at between 40 and 80 cycles per minute, and could provide a flow rate that could be set to a particular value. The fluid used was bovine whole blood to which heparin had been added and that was maintained at an elevated temperature to maintain physiological viscosity. For the experiments described below, the blood was pumped at 60 cycles per minute and at a flow rate of 500 mL per minute.

[0071] A light emitter array was disposed opposite a light sensor array with the excised porcine carotid artery disposed therebetween. The light emitter array included five light emitting diodes that emitted light at 660 nm. The light sensor array included a linear CCD array composed of 250 elements arranged side-by-side, with each group or set of 20 elements fitting into 1 mm of contiguous space along the array. The system was operated for 10 seconds, with the results of the experiments plotted in Fig. 12. The inner diameter of the vessel was determined by using the distance between a pair of positions where the magnitude of the pulsatile component was 50% of the peak magnitude.

[0072] The second set of experiments was conducted using a light emitter array opposite a light sensor array, with the porcine carotid artery of a living porcine subject disposed therebetween. The light sensor array included five light emitting diodes that emitted light at 660 nm. The light sensor array included 16 individual photodetector elements, each element being 0.9mm wide. The elements were spaced with 0.1 mm between adjacent elements, such that each element occupied 1mm of contiguous space along the array. The system was operated for 15 seconds, with the results of the experiment plotted in Fig. 13. The measurements for each photodetector were interpolated and converted to pixels to permit a comparison between the first set of experiments and the second set of experiments. Again, the inner diameter of the vessel was determined by using the distance between a pair of positions where the magnitude of the pulsatile component was 50% of the peak magnitude (i.e., line C in Fig. 13).

[0073] In both sets of experiments, the inner diameters of the porcine arteries determined using embodiments of the disclosed system were within a millimeter of the gross diameter measurements of the vessel. For example, relative to the first set of experiments, the inner diameter determined using the embodiment of the system was 4.7 mm, while the gross diameter measurement was 4.46 mm. As to the second set of experiments, the inner diameter determined using the embodiment of the system was 1.35 mm, and the gross diameter measurement was 1.1 mm.

[0074] For a third set of experiments, an embodiment of the system including an LED array emitting at 940 nm and a linear CCD array was used. The system was used to determine the resting outer diameters of four different arteries (gastric, left renal, right renal, and abdominal) in a living porcine subject. The system was operated for 10 seconds, and the inner diameters were determined using a pair of points associated with 50% of the peak magnitude. After using the system to determine the inner diameters, the arteries were excised and the gross vessel diameters were obtained by quantifying the cross-section of the vessels at the point of measurement along the vessels using NIH ImageJ software.

[0075] The results of the third group of experiments are illustrated in Fig. 14. As indicated in the graph, there is a close correlation between the inner diameters determined using an embodiment of the system disclosed herein and the inner diameters measured using conventional techniques. The error bars represent the standard deviation of measurements of the same artery taken at different points in time.

[0076] Additionally, four sets of experiments were conducted in regard to the method of edge determination disclosed above. The experiments were conducted using a u value of 4. Thus, for a sampling rate of FS, the time taken to compute r would be $4/FS$ which would be approximately 0.4s for the slowest sampling rate (10Hz).

Experiment I

[0077] This experiment was conducted with a blood vessel at the edge of the jaw. As illustrated in Figs 15 and 16, the edge of the vessel is apparent based on the magnitude of the ratio.

Experiment II

[0078] This experiment was conducted with only tissue at the edge of the jaw. The magnitude of the ratio is higher at the edge but is not as significant as that of the blood vessel (Experiment I). See Figs. 17 and 18.

Experiment III

5 [0079] This experiment was conducted with both a blood vessel and tissue inside the jaws. As illustrated in Figs. 19 and 20, there is a clear distinction between the tissue and the blood vessel. Since the tissue was moving with the vessel, the magnitude of the ratio for the tissue is not very small. However, this does not present an issue as a large value for the ratio is present, resulting in the knowledge that the surgical instrument is reaching either a blood vessel or a tissue attached to one. In either event, the analyzer can provide an indication that the jaws are approaching blood vessel.

Experiment IV

10 [0080] This experiment was conducted using a blood vessel and an adipose tissue with the tissue being at the end of the jaw. As illustrated in the Figs. 21 and 22, the ratio may be used to distinguish between the vessel and the tissue.

15 [0081] In conclusion, although the preceding text sets forth a detailed description of different embodiments of the invention, it should be understood that the legal scope of the invention is defined by the words of the claims set forth at the end of this patent. The detailed description is to be construed as exemplary only and does not describe every possible embodiment of the invention since describing every possible embodiment would be impractical, if not impossible. Numerous alternative embodiments could be implemented, using either current technology or technology developed after the filing date of this patent, which would still fall within the scope of the claims defining the invention.

20 It should also be understood that, unless a term is expressly defined in this patent using the sentence "As used herein, the term '_____ ' is hereby defined to mean..." or a similar sentence, there is no intent to limit the meaning of that term, either expressly or by implication, beyond its plain or ordinary meaning, and such term should not be interpreted to be limited in scope based on any statement made in any section of this patent (other than the language of the claims). To the extent that any term recited in the claims at the end of this patent is referred to in this patent in a manner consistent with a single meaning, that is done for sake of clarity only so as to not confuse the reader, and it is not intended that such claim term be limited, by implication or otherwise, to that single meaning.

25

Claims

30 1. A surgical system (100) to determine a size of a vessel (V) within a region (102) proximate to a working end (104) of a surgical instrument, (106) comprising:

35 at least one light emitter (110) disposed at the working end of the surgical instrument;
 an array of light sensors (112) disposed at the working end of the surgical instrument opposite the at least one light emitter, the array of light sensors comprising at least one row of light sensors, and
 a controller (114) coupled to the array of light sensors,
characterised in that individual light sensors in the row of light sensors are adapted to generate a signal comprising a first pulsatile component and a second non-pulsatile component and that the controller comprises a
 40 splitter (116) to separate the first pulsatile component from the second non-pulsatile component and an analyzer (118) to determine the magnitudes of the pulsatile and non-pulsatile components at the individual light sensors in the row of light sensors, to determine a first peak magnitude and a second peak magnitude of the pulsatile components, to determine a resting outer diameter of the vessel based on the first and second peak magnitudes of the pulsatile components.

45

2. The surgical system (100) according to claim 1, wherein the analyzer (118) determines a pair of positions along the row of light sensors (112) where the magnitudes of the pulsatile component are a percentage of the first or second peak magnitude, the pair of positions disposed between the positions corresponding to the first and second peak magnitudes, determines a distance between the pair of positions, and determines the resting outer diameter of the vessel (V) based on the distance.

50

3. The surgical system (100) according to claim 1, wherein the analyzer (118) determines a first pair and a second pair of positions along the row of light sensors (112) where the magnitudes of the pulsatile component are a percentage of the first or second peak magnitude, the second pair of positions being disposed between the first pair of positions, determines a first distance between the first pair of positions and a second distance between the second pair of positions, and determines the resting outer diameter of the vessel (V) as the average of the first and second distances.

55

4. The surgical system (100) according to claim 3, wherein the percentage is 50%.
5. The surgical system (100) according to claim 1, wherein the first pulsatile component comprises an alternating current signal component and the second non-pulsatile component comprises a direct current signal component.
6. The surgical system (100) according to claim 1, wherein the controller (114) comprises a processor and memory, and the splitter (116) comprises the processor programmed to separate the first pulsatile component from the second non-pulsatile component and the analyzer (118) comprises the processor programmed to determine the magnitudes of the pulsatile and non-pulsatile components at the individual light sensors (112) in the row of light sensors, to determine a first peak magnitude and a second peak magnitude of the pulsatile components, to determine a resting outer diameter of the vessel (V) based on the first and second peak magnitudes along the row of light sensors.
7. The surgical system (110) according to claim 6, wherein the analyzer (118) comprises the processor programmed to determine a pair of positions along the row of light sensors where the magnitudes of the pulsatile component are a percentage of the first or second peak magnitude, the pair of positions disposed between the positions corresponding to the first and second peak magnitudes, to determine a distance between the pair of positions, and to determine the resting outer diameter of the vessel (V) based on the distance.
8. The surgical system (110) according to claim 6, wherein the analyzer (118) comprises the processor programmed to determine a first pair and a second pair of positions along the row of light sensors (112) where the magnitudes of the pulsatile component are a percentage of the first or second peak magnitude, the second pair of positions being disposed between the first pair of positions, to determine a first distance between the first pair of positions and a second distance between the second pair of positions, and to determine the resting outer diameter of the vessel (V) as the average of the first and second distances.
9. The surgical system (110) according to claim 8, wherein the percentage is 50%.
10. The surgical system (110) according to any one of claims 1-9, wherein the array of light sensors (112) comprises a linear CCD array.
11. The surgical system (110) according to any one of claims 1-10, further comprising a surgical instrument (106) having a working end (104).
12. The surgical system (100) according to claim 11, wherein the surgical instrument comprises first and second opposing jaw elements (180), the at least one light emitter disposed on the first jaw element and the array of light sensors (112) is disposed on the second, opposing jaw element.
13. The surgical system (100) according to claim 12, wherein the surgical instrument (106) is a grasper.
14. The surgical system (100) according to claim 12, wherein the surgical instrument (106) is a thermal ligature device.

Patentansprüche

1. Chirurgisches System (100) zur Bestimmung einer Größe eines Gefäßes (V) innerhalb eines Bereichs (102) in der Nähe eines Arbeitendes (104) eines chirurgischen Instruments (106), wobei das System Folgendes umfasst:
- mindestens einen Lichtemitter (110), der am Arbeitende des chirurgischen Instruments angeordnet ist;
eine Anordnung von Lichtsensoren (112), die an dem Arbeitende des chirurgischen Instruments gegenüber dem mindestens einen Lichtemitter angeordnet sind, wobei die Anordnung von Lichtsensoren mindestens eine Reihe von Lichtsensoren umfasst, und
eine Steuereinheit (114), die mit der Anordnung von Lichtsensoren gekoppelt ist, **dadurch gekennzeichnet, dass** einzelne Lichtsensoren in der Reihe von Lichtsensoren dazu ausgelegt sind, ein Signal zu erzeugen, das eine erste pulsierende Komponente und eine zweite nicht pulsierende Komponente umfasst und dass die Steuereinheit Folgendes umfasst: einen Splitter (116) zum Trennen der ersten pulsierenden Komponente von der zweiten nicht pulsierenden Komponente und einen Analysator (118) zum Bestimmen der Größen der pulsierenden und nicht pulsierenden Komponenten an den einzelnen Lichtsensoren in der Reihe der Lichtsensoren, zum Bestimmen einer ersten Spitzengröße und einer zweiten Spitzengröße der pulsierenden Komponenten,

zum Bestimmen eines ruhenden Außendurchmessers des Gefäßes basierend auf den ersten und zweiten Spitzengrößen der pulsierenden Komponenten.

- 5 2. Chirurgisches System (100) nach Anspruch 1, wobei der Analysator (118) ein Paar von Positionen entlang der Reihe von Lichtsensoren (112) bestimmt, wobei die Größen der pulsierenden Komponente einen Prozentsatz der ersten oder zweiten Spitzengröße darstellen, wobei das Paar von Positionen, die zwischen den Positionen angeordnet sind, die den ersten und zweiten Spitzengrößen entsprechen, einen Abstand zwischen dem Paar von Positionen bestimmen, und den ruhenden Außendurchmesser des Gefäßes (V) anhand der Entfernung bestimmen.
- 10 3. Chirurgisches System (100) nach Anspruch 1, wobei der Analysator (118) Folgendes bestimmt: ein erstes Paar und ein zweites Paar Positionen entlang der Reihe von Lichtsensoren (112), wobei die Größen der pulsierenden Komponente ein Prozentsatz der ersten oder zweiten Spitzengröße sind, wobei das zweite Paar von Positionen zwischen dem ersten Paar von Positionen angeordnet ist, einen ersten Abstand zwischen dem ersten Paar von Positionen und einen zweiten Abstand zwischen dem zweiten Paar von Positionen, und den ruhenden Außendurchmesser des Gefäßes (V) als Durchschnitt der ersten und zweiten Entfernung.
- 15 4. Chirurgisches System (100) nach Anspruch 3, wobei der Prozentsatz 50% beträgt.
- 20 5. Chirurgisches System (100) nach Anspruch 1, wobei die erste pulsierende Komponente eine Wechselstromsignal-komponente umfasst und die zweite nicht pulsierende Komponente eine Gleichstromsignal-komponente umfasst.
- 25 6. Chirurgisches System (100) nach Anspruch 1, wobei die Steuereinheit (114) einen Prozessor und einen Speicher umfasst, und der Splitter (116) den Prozessor umfasst, der dafür programmiert ist, die erste pulsierende Komponente von der zweiten nicht pulsierenden Komponente zu trennen, und der Analysator (118) den programmierten Prozessor umfasst, der für Folgendes programmiert ist: zum Bestimmen der Größen der pulsierenden und nicht pulsierenden Komponenten an den einzelnen Lichtsensoren (112) in der Reihe der Lichtsensoren, zum Bestimmen einer ersten Spitzengröße und einer zweiten Spitzengröße der pulsierenden Komponenten, zum Bestimmen eines ruhenden Außendurchmessers des Gefäßes (V) basierend auf der ersten und der zweiten Spitzengröße entlang der Reihe von Lichtsensoren.
- 30 7. Chirurgisches System (110) nach Anspruch 6, wobei der Analysator (118) den Prozessor umfasst, der für Folgendes programmiert ist: Bestimmen eines Paares von Positionen entlang der Reihe von Lichtsensoren, wobei die Größen der pulsierenden Komponente einen Prozentsatz der ersten oder zweiten Spitzengröße darstellen und das Paar von Positionen, die zwischen den Positionen angeordnet sind, der ersten und der zweiten Spitzengröße entspricht, Bestimmen eines Abstands zwischen dem Paar von Positionen und Bestimmen des ruhenden Außendurchmessers des Gefäßes (V) anhand der Entfernung.
- 35 8. Chirurgisches System (110) nach Anspruch 6, wobei der Analysator (118) den Prozessor umfasst, der für Folgendes programmiert ist: Bestimmen eines ersten Paares und eines zweiten Paares von Positionen entlang der Reihe von Lichtsensoren (112), wobei die Größen der pulsierenden Komponente ein Prozentsatz der ersten oder zweiten Spitzengröße sind und das zweite Paar von Positionen zwischen dem ersten Paar von Positionen angeordnet ist, Bestimmen eines ersten Abstands zwischen dem ersten Paar von Positionen und eines zweiten Abstands zwischen dem zweiten Paar von Positionen, und Bestimmen des ruhenden Außendurchmessers des Gefäßes (V) als Durchschnitt der ersten und zweiten Entfernung.
- 40 9. Chirurgisches System (110) nach Anspruch 8, wobei der Prozentsatz 50% beträgt.
- 45 10. Chirurgisches System (110) nach einem der Ansprüche 1 bis 9, wobei die Anordnung von Lichtsensoren (112) eine lineare CCD-Anordnung umfasst.
- 50 11. Chirurgisches System (110) nach einem der Ansprüche 1 bis 10, das ferner ein chirurgisches Instrument (106) mit einem Arbeitsende (104) umfasst.
- 55 12. Chirurgisches System (100) nach Anspruch 11, wobei das chirurgische Instrument ein erstes und ein zweites gegenüberliegendes Backenelement (180) umfasst, wobei der mindestens eine Lichtemitter an dem ersten Backenelement angeordnet ist und die Anordnung von Lichtsensoren (112) an dem zweiten, gegenüberliegenden Backenelement angeordnet ist.

13. Chirurgisches System (100) nach Anspruch 12, wobei das chirurgische Instrument (106) ein Greifer ist.
14. Chirurgisches System (100) nach Anspruch 12, wobei das chirurgische Instrument (106) eine thermische Ligaturvorrichtung ist.

5

Revendications

1. Système chirurgical (100) permettant de déterminer la taille d'un vaisseau (V) dans une région (102) à proximité d'une extrémité de travail (104) d'un instrument chirurgical (106), comprenant :

10

au moins un émetteur de lumière (110) disposé au niveau de l'extrémité de travail de l'instrument chirurgical ; un réseau de capteurs de lumière (112) disposé au niveau de l'extrémité de travail de l'instrument chirurgical à l'opposé de l'au moins un émetteur de lumière, le réseau de capteurs de lumière comprenant au moins une rangée de capteurs de lumière, et

15

un dispositif de commande (114) couplé au réseau de capteurs de lumières,

caractérisé en ce que des capteurs de lumière individuels dans la rangée de capteurs de lumière sont adaptés pour générer un signal comprenant une première composante pulsatile et une deuxième composante non pulsatile et **en ce que** le dispositif de commande comprend un diviseur (116) pour séparer la première composante pulsatile de la deuxième composante non pulsatile et un analyseur (118) pour déterminer les ampleurs des composantes pulsatile et non pulsatile au niveau des capteurs de lumière individuels dans la rangée de capteurs de lumière, pour déterminer un premier pic d'ampleur et un deuxième pic d'ampleur des composantes pulsatiles, pour déterminer un diamètre externe de repos du vaisseau sur la base des premier et deuxième pics d'ampleur des composantes pulsatiles.

25

2. Système chirurgical (100) selon la revendication 1, dans lequel l'analyseur (118) détermine une paire de positions le long de la rangée de capteurs de lumière (112) auxquelles les ampleurs de la composante pulsatile sont un pourcentage du premier ou du deuxième pic d'ampleur, la paire de positions étant disposées entre les positions correspondant aux premier et deuxième pics d'ampleur, détermine une distance entre la paire de positions et détermine le diamètre externe de repos du vaisseau (V) sur la base de la distance.

30

3. Système chirurgical (100) selon la revendication 1, dans lequel l'analyseur (118) détermine une première paire et une deuxième paire de positions le long de la rangée de capteurs de lumière (112) auxquelles les ampleurs de la composante pulsatile sont un pourcentage du premier ou du deuxième pic d'ampleur, la deuxième paire de positions étant disposées entre la première paire de positions, détermine une première distance entre la première paire de positions et une deuxième distance entre la deuxième paire de positions et détermine le diamètre externe de repos du vaisseau (V) en tant que moyenne des première et deuxième distances.

35

4. Système chirurgical (100) selon la revendication 3, dans lequel le pourcentage est de 50 %.

40

5. Système chirurgical (100) selon la revendication 1, dans lequel la première composante pulsatile comprend une composante de signal de courant alternatif et la deuxième composante non pulsatile comprend une composante de signal de courant continu.

45

6. Système chirurgical (100) selon la revendication 1, dans lequel le dispositif de commande (114) comprend un processeur et une mémoire, et le diviseur (116) comprend le processeur programmé pour séparer la première composante pulsatile de la deuxième composante non pulsatile et l'analyseur (118) comprend le processeur programmé pour déterminer les ampleurs des composantes pulsatile et non pulsatile au niveau des capteurs de lumière individuels (112) dans la rangée de capteurs de lumière, pour déterminer un premier pic d'ampleur et un deuxième pic d'ampleur des composantes pulsatiles, pour déterminer un diamètre externe de repos du vaisseau (V) sur la base des premier et deuxième pics d'ampleur le long de la rangée de capteurs de lumière.

50

7. Système chirurgical (110) selon la revendication 6, dans lequel l'analyseur (118) comprend le processeur programmé pour déterminer une paire de positions le long de la rangée de capteurs de lumière auxquelles les ampleurs de la composante pulsatile sont un pourcentage du premier ou du deuxième pic d'ampleur, la paire de positions étant disposées entre les positions correspondant aux premier et deuxième pics d'ampleur, pour déterminer une distance entre la paire de positions, et pour déterminer le diamètre externe de repos du vaisseau (V) sur la base de la distance.

55

EP 3 258 841 B1

- 5
8. Système chirurgical (110) selon la revendication 6, dans lequel l'analyseur (118) comprend le processeur programmé pour déterminer une première paire et une deuxième paire de positions le long de la rangée de capteurs de lumière (112) auxquelles les amplitudes de la composante pulsatile sont un pourcentage du premier ou du deuxième pic d'amplitude, la deuxième paire de positions étant disposées entre la première paire de positions, pour déterminer une première distance entre la première paire de positions et une deuxième distance entre la deuxième paire de positions, et pour déterminer le diamètre externe de repos du vaisseau (V) en tant que moyenne des première et deuxième distances.
- 10
9. Système chirurgical (110) selon la revendication 8, dans lequel le pourcentage est de 50 %.
- 15
10. Système chirurgical (110) selon l'une quelconque des revendications 1 à 9, dans lequel le réseau de capteurs de lumière (112) comprend un réseau de DCC linéaire.
- 20
11. Système chirurgical (110) selon l'une quelconque des revendications 1 à 10, comprenant en outre un instrument chirurgical (106) ayant une extrémité de travail (104).
- 25
12. Système chirurgical (100) selon la revendication 11, dans lequel l'instrument chirurgical comprend des premier et deuxième éléments de mâchoire opposés (180), l'au moins un émetteur de lumière étant disposé sur le premier élément de mâchoire et le réseau de capteurs de lumière (112) étant disposé sur le deuxième élément de mâchoire opposé.
- 30
13. Système chirurgical (100) selon la revendication 12, dans lequel l'instrument chirurgical (106) est un préhenseur.
- 35
- 40
- 45
- 50
- 55
14. Système chirurgical (100) selon la revendication 12, dans lequel l'instrument chirurgical (106) est un dispositif de ligature thermique.

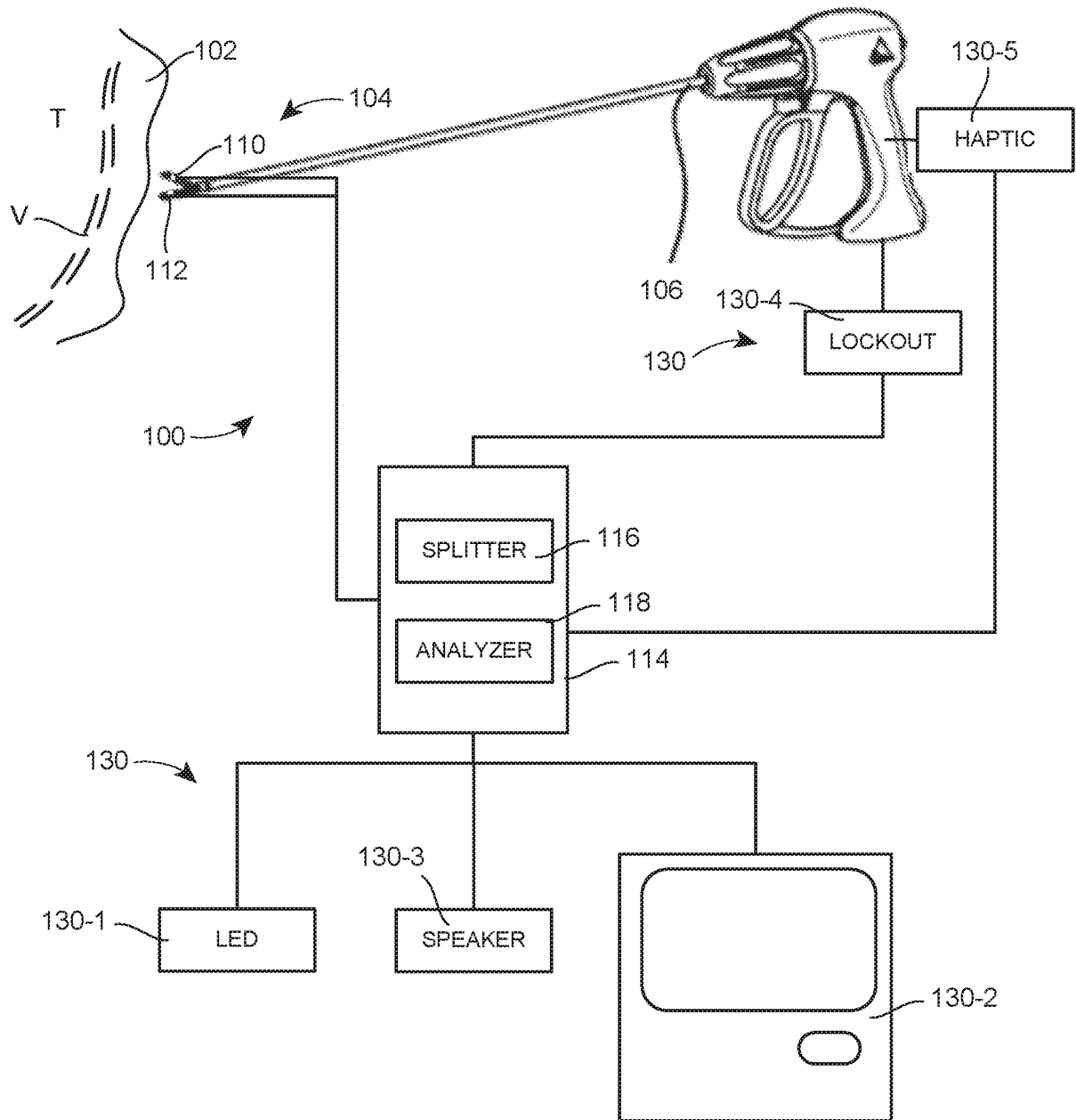

FIG. 1

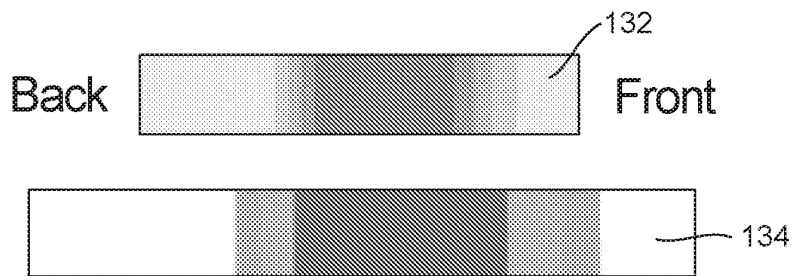

FIG. 11

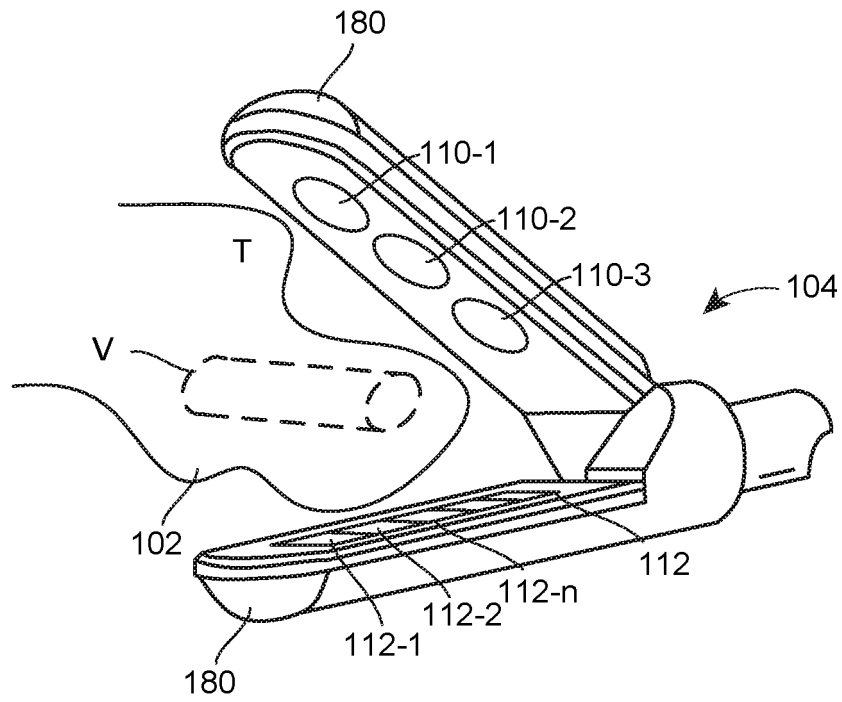

FIG. 2

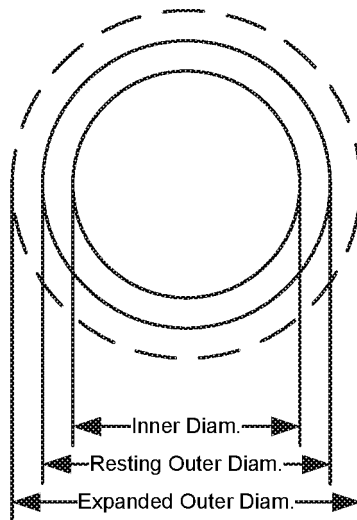

FIG. 3

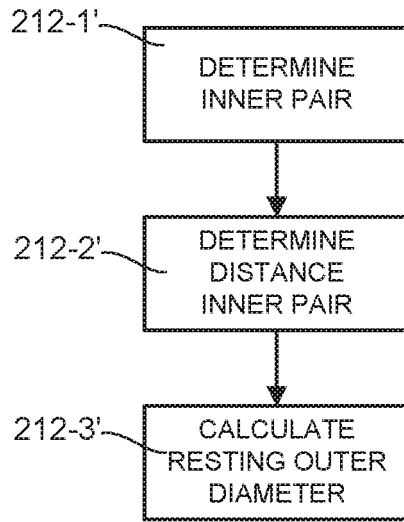

FIG. 7

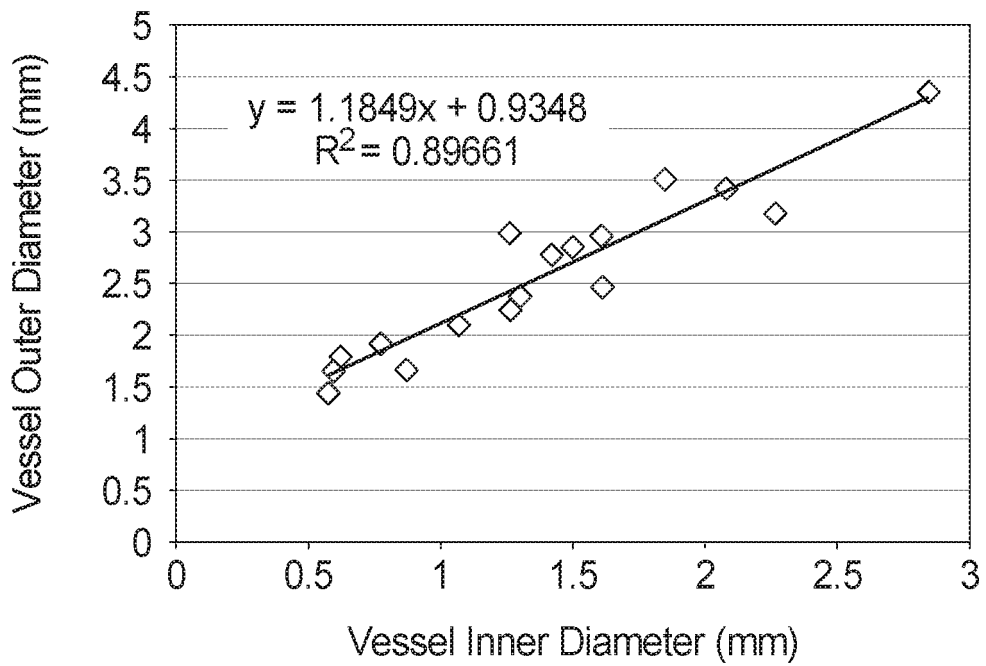

FIG. 8

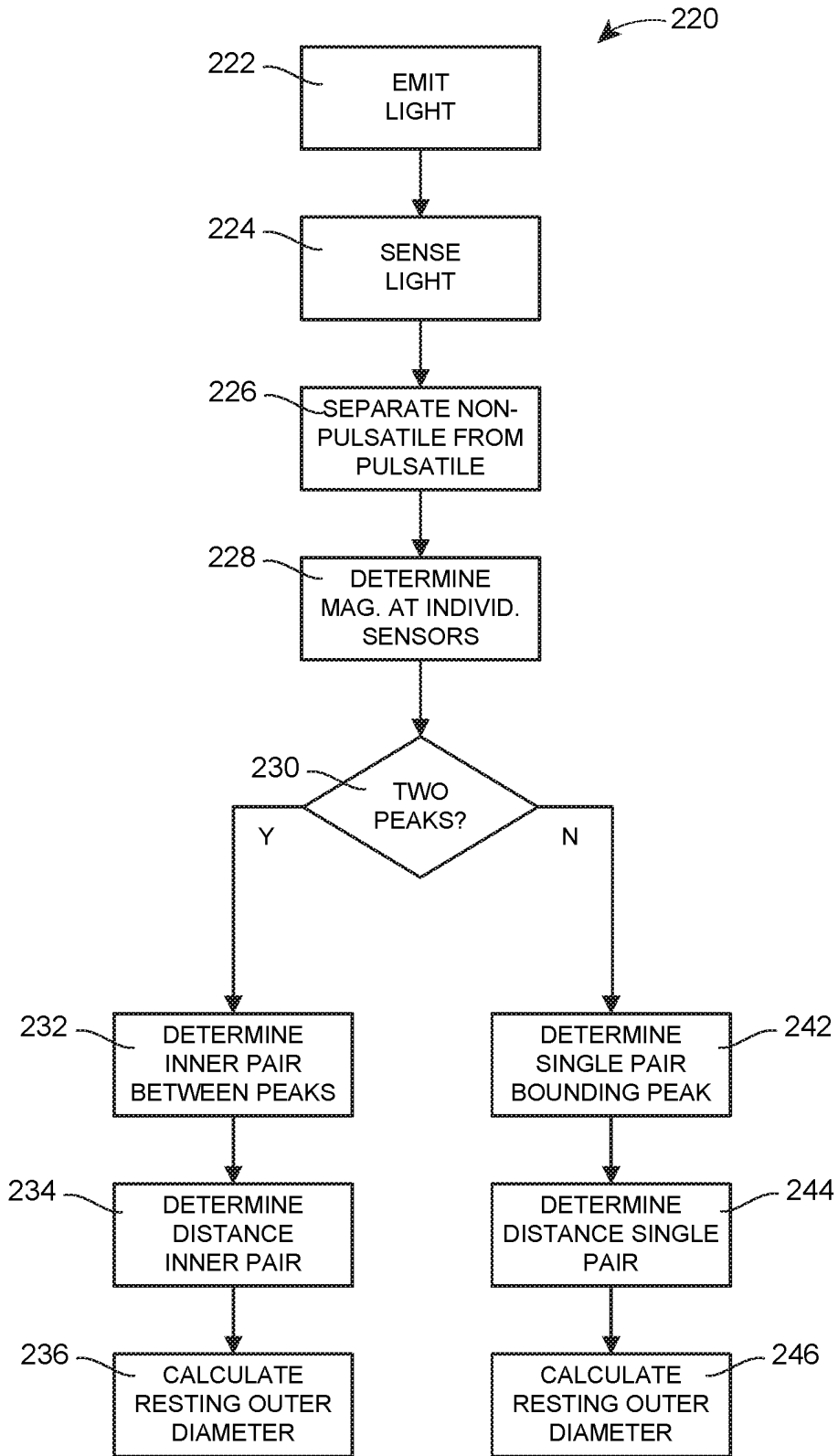

FIG. 9

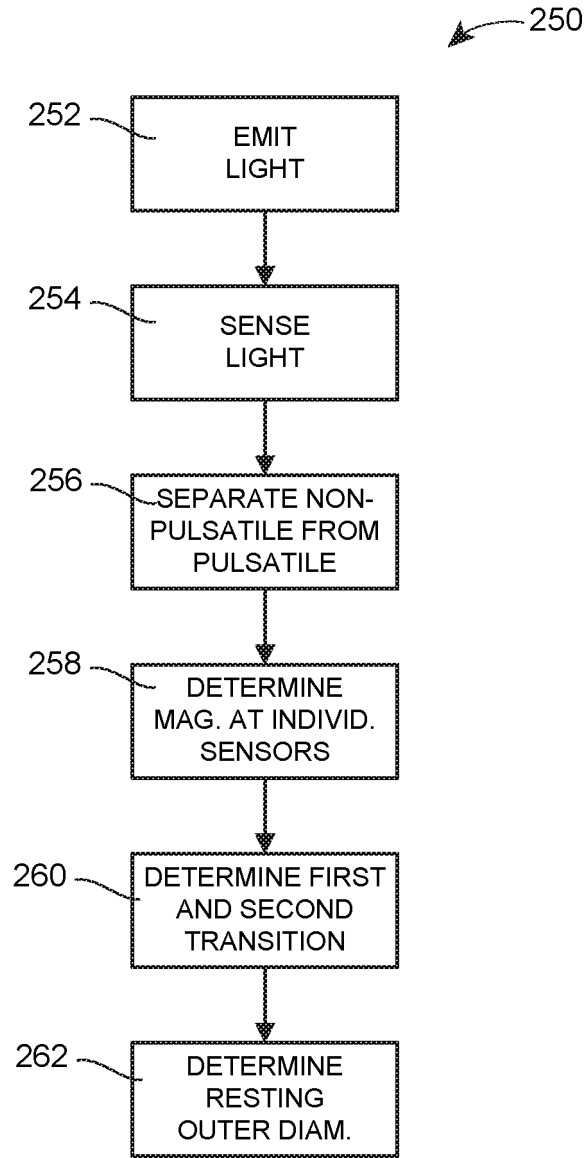

FIG. 10

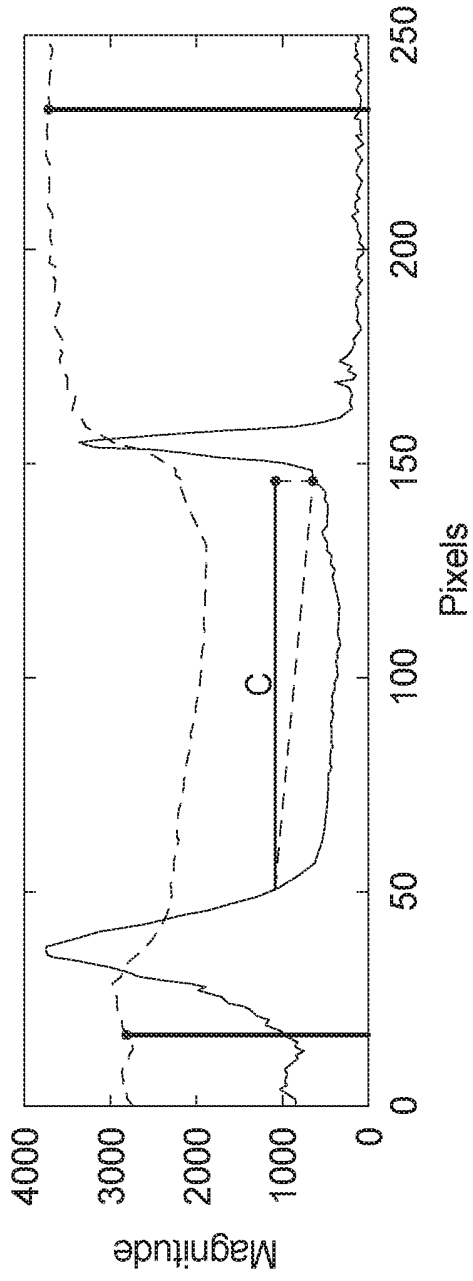

FIG. 12

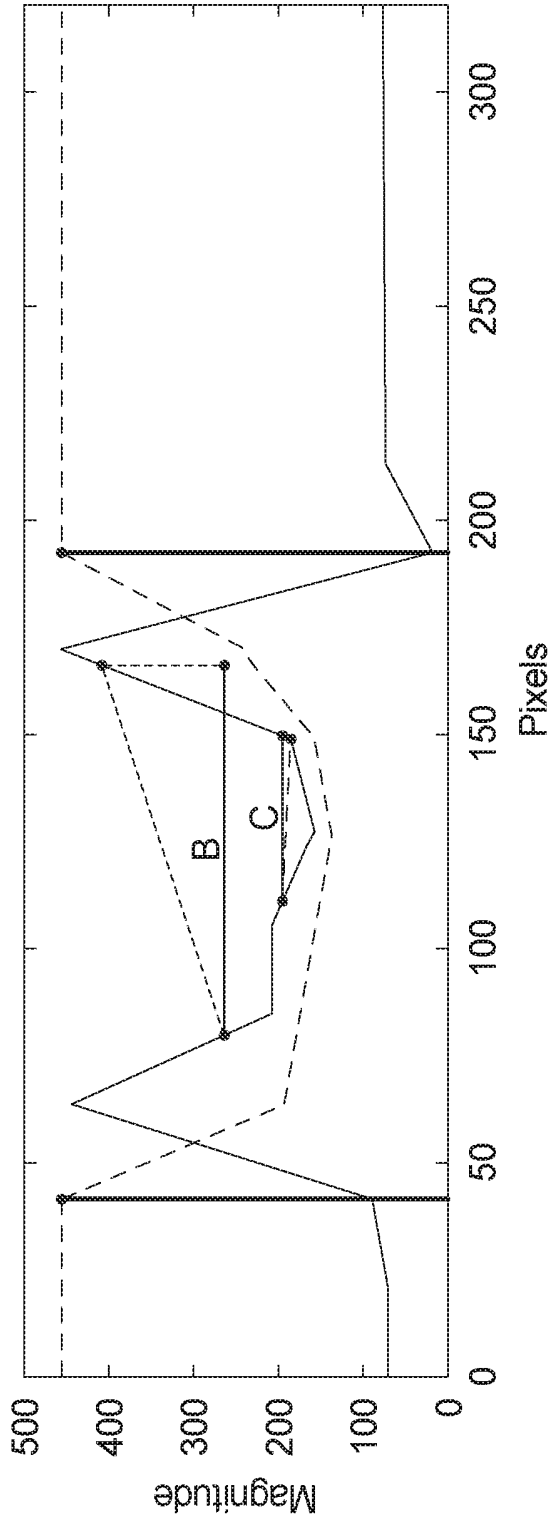

FIG. 13

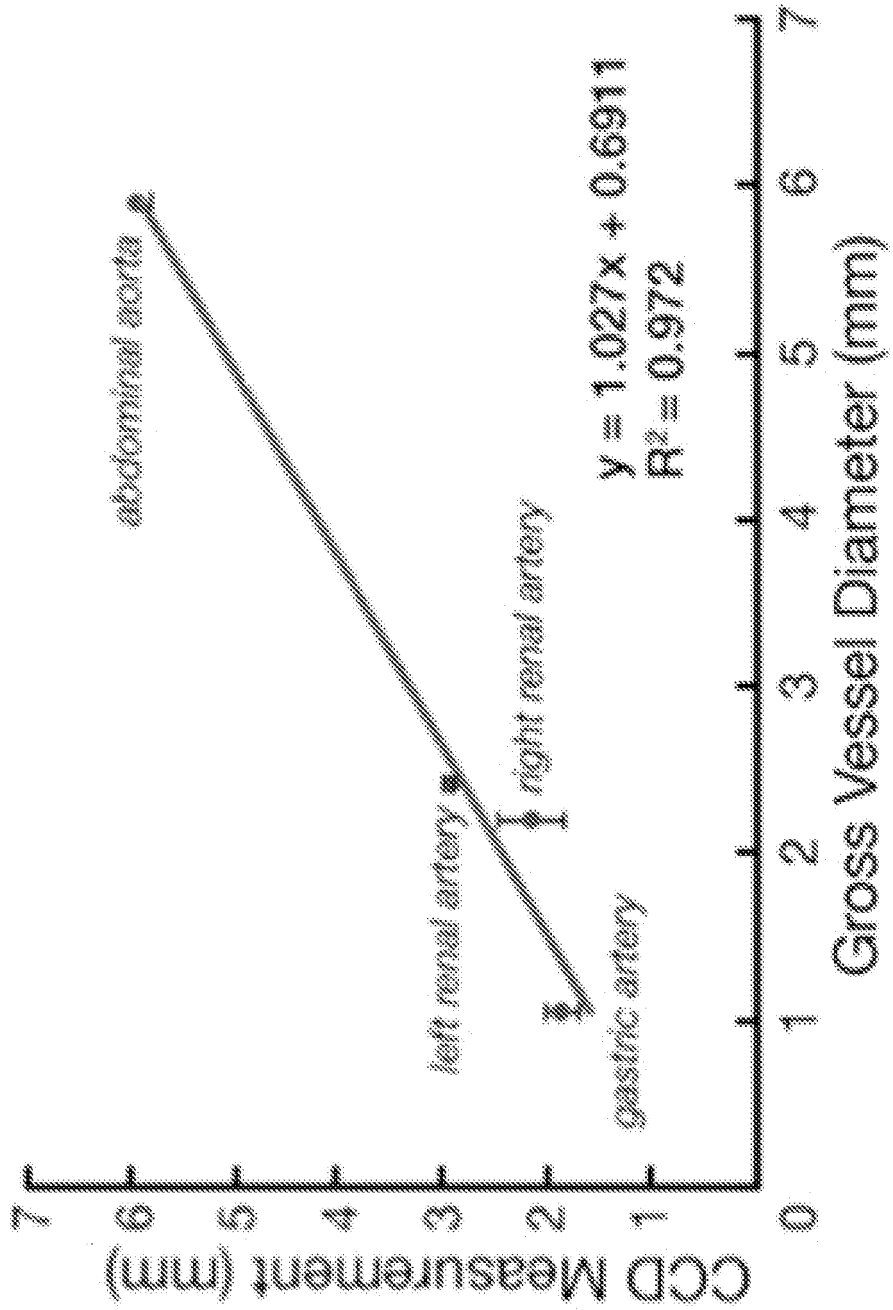

FIG. 14

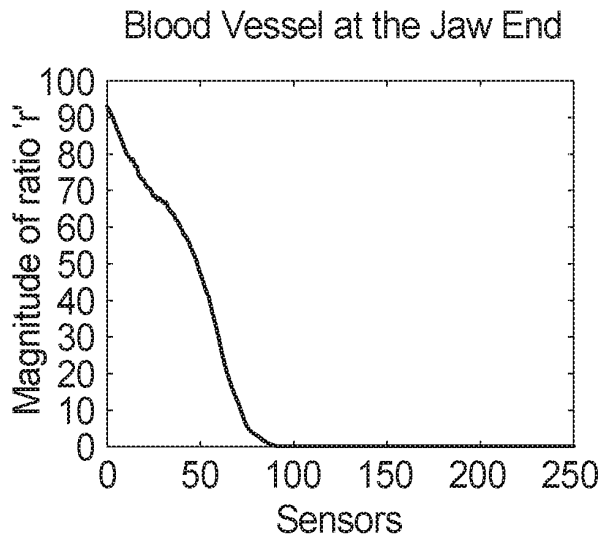

FIG. 15

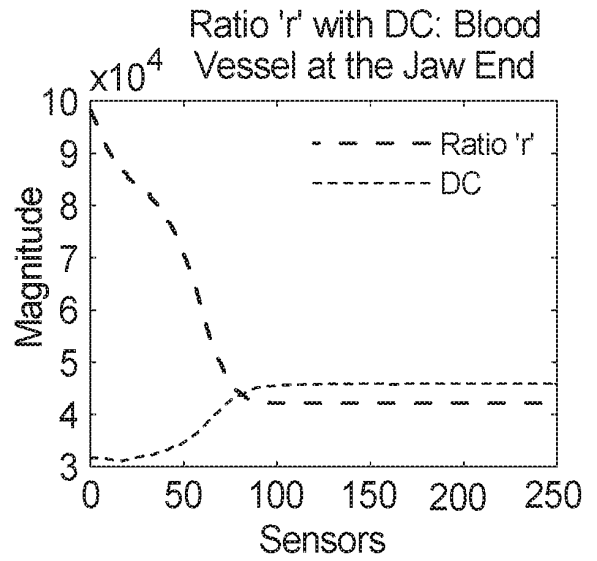

FIG. 16

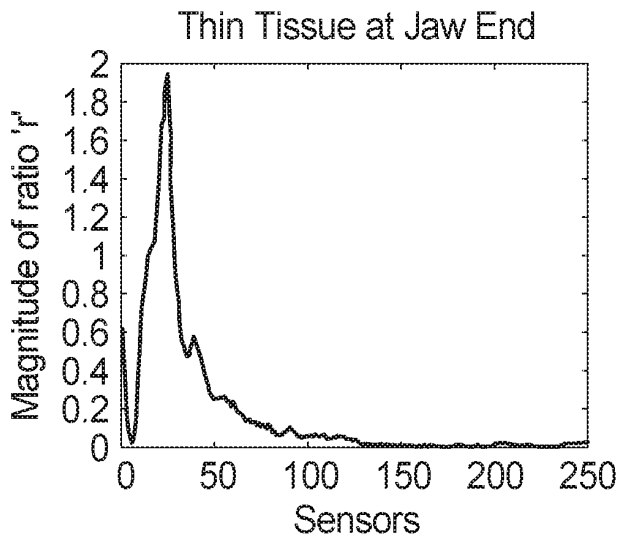

FIG. 17

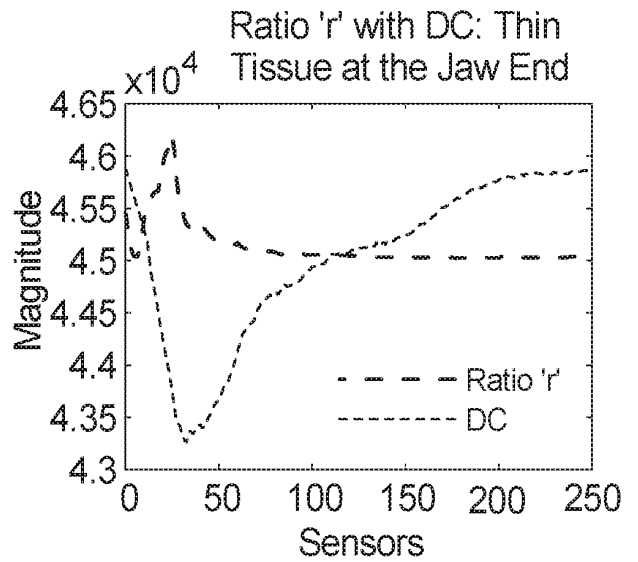

FIG. 18

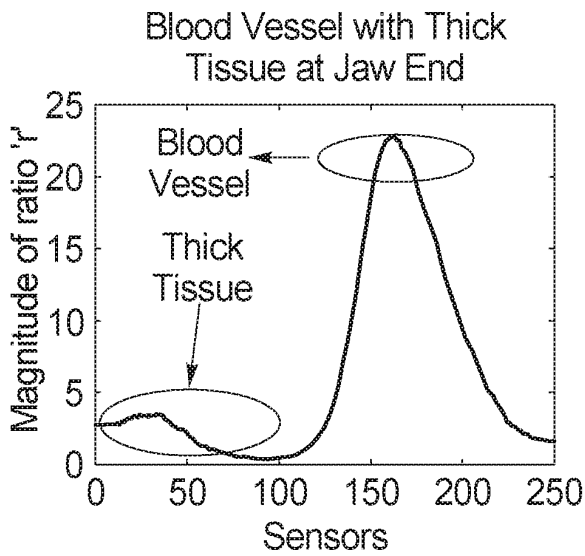

FIG. 19

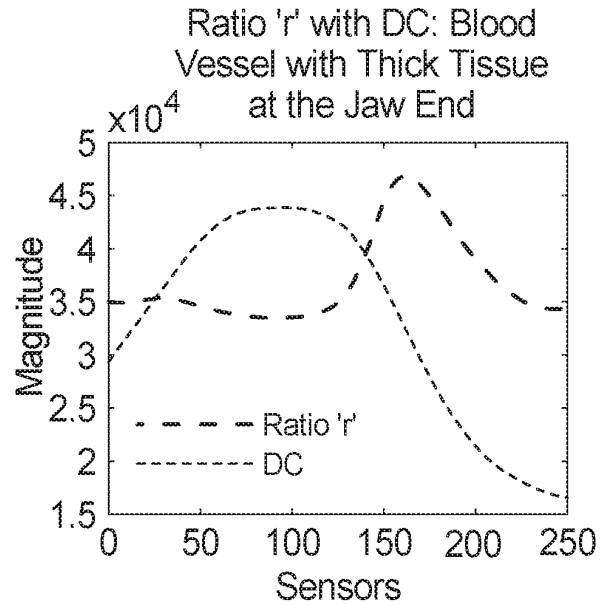

FIG. 20

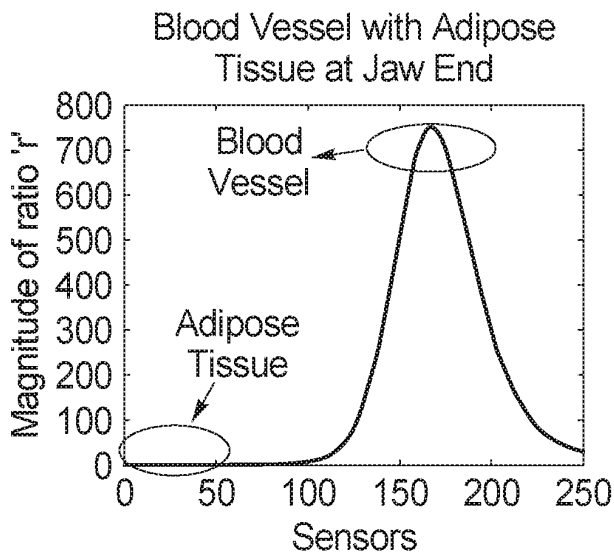

FIG. 21

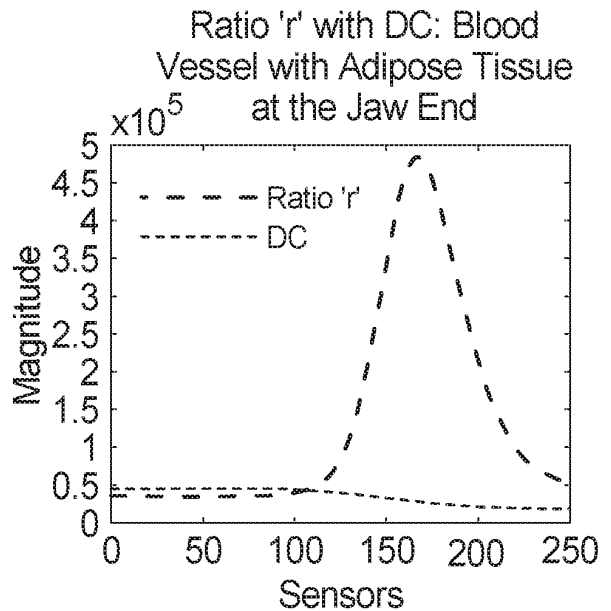

FIG. 22

REFERENCES CITED IN THE DESCRIPTION

This list of references cited by the applicant is for the reader's convenience only. It does not form part of the European patent document. Even though great care has been taken in compiling the references, errors or omissions cannot be excluded and the EPO disclaims all liability in this regard.

Patent documents cited in the description

- WO 2013134411 A [0002]

专利名称(译)	用于确定容器尺寸和/或边缘的系统		
公开(公告)号	EP3258841B1	公开(公告)日	2019-04-10
申请号	EP2016707602	申请日	2016-02-19
[标]申请(专利权)人(译)	BRITSEED		
[标]发明人	CHATURVEDI AMAL SUBRAMANIAN HARIHARAN GUNN JONATHAN VIJAYVERGIA MAYANK SHUKAIR SHETHA LE ROLLAND PAUL		
发明人	CHATURVEDI, AMAL SUBRAMANIAN, HARIHARAN GUNN, JONATHAN VIJAYVERGIA, MAYANK SHUKAIR, SHETHA LE ROLLAND, PAUL		
IPC分类号	A61B5/024 A61B5/1459 A61B5/02 A61B5/107 A61B5/00		
代理机构(译)	J A KEMP		
优先权	62/118443 2015-02-19 US 62/118554 2015-02-20 US		
其他公开文献	EP3258841A1		
外部链接	Espacenet		

摘要(译)

用于确定靠近手术器械的工作端的区域内的血管尺寸的手术系统包括设置在工作端的至少一个光发射器，与所述至少一个光发射器相对设置的光传感器阵列，阵列包括至少一排光传感器，该行中的各个光传感器适于产生包括脉动和非脉动部件的信号，以及耦合到该阵列的控制器，该控制器包括分离器以将脉动部件与非脉动部件，以及用于确定各个光传感器上的脉动和非脉动部件的大小的分析器，以确定脉动部件的第一峰值幅度和第二峰值幅度，并确定静止外径基于第一和第二峰值幅度的船舶。

$$I(t) = I_0 e^{-a(t)L}$$