



(11) **EP 2 557 988 B1**

(12) **EUROPEAN PATENT SPECIFICATION**

(45) Date of publication and mention of the grant of the patent:
24.06.2020 Bulletin 2020/26

(51) Int Cl.:
A61B 7/00 (2006.01) G16H 50/30 (2018.01)
G16H 50/70 (2018.01) G16H 50/20 (2018.01)
A61B 5/00 (2006.01) A61B 7/04 (2006.01)

(21) Application number: **11769638.5**

(86) International application number:
PCT/US2011/032616

(22) Date of filing: **15.04.2011**

(87) International publication number:
WO 2011/130589 (20.10.2011 Gazette 2011/42)

(54) **SYSTEM FOR PREDICTING GASTROINTESTINAL IMPAIRMENT**

SYSTEM ZUR VORHERSAGE VON MAGEN-DARM-ERKRANKUNGEN

SYSTÈME POUR PRÉDIRE UN TROUBLE GASTRO-INTESTINAL

(84) Designated Contracting States:
AL AT BE BG CH CY CZ DE DK EE ES FI FR GB GR HR HU IE IS IT LI LT LU LV MC MK MT NL NO PL PT RO RS SE SI SK SM TR

(30) Priority: **16.04.2010 US 324879 P**

(43) Date of publication of application:
20.02.2013 Bulletin 2013/08

(73) Proprietor: **University of Tennessee Research Foundation**
Knoxville, TN 37996-4122 (US)

(72) Inventor: **CROMWELL, John, W.**
Iowa City
IA 52242 (US)

(74) Representative: **MacDougall, Alan John Shaw**
Mathys & Squire LLP
The Shard
32 London Bridge Street
London SE1 9SG (GB)

(56) References cited:
US-A- 5 140 994 US-A- 5 301 679
US-A1- 2002 052 559 US-A1- 2002 156 398
US-A1- 2002 156 398 US-A1- 2008 306 355
US-B1- 6 287 266

- **TOMOMASA TAKESHI ET AL: "Gastrointestinal sounds and migrating motor complex in fasted humans", AMERICAN JOURNAL OF GASTROENTEROLOGY, ELSEVIER SCIENCE INC, US, vol. 94, no. 2, 1 February 1999 (1999-02-01), pages 374-381, XP002931927, ISSN: 0002-9270, DOI: 10.1111/J.1572-0241.1999.00862.X**

EP 2 557 988 B1

Note: Within nine months of the publication of the mention of the grant of the European patent in the European Patent Bulletin, any person may give notice to the European Patent Office of opposition to that patent, in accordance with the Implementing Regulations. Notice of opposition shall not be deemed to have been filed until the opposition fee has been paid. (Art. 99(1) European Patent Convention).

Description

Cross-Reference To Related Application

- 5 **[0001]** This application claims priority to co-pending U.S. Provisional Application having serial number 61/324,879, filed April 16, 2010.

Background

- 10 **[0002]** Gastrointestinal impairment (GII) is common following surgical procedures. Such impairment is often the result of postoperative ileus, a condition in which a portion of the intestines is temporarily paralyzed and therefore cannot process food. Although GII most often occurs after an abdominal surgery, it is not uncommon for GII to occur after other types of surgery. In addition to interfering with postoperative oral feeding, GII can cause abdominal distension, nausea, emesis, and pulmonary aspiration.
- 15 **[0003]** Concern over GII often results in the implementation of various postoperative care protocols that prolong hospitalization, even though the majority of patients will not experience GII. Such protocols often include the use nasogastric tubes, motility agents, and hyperalimentation. In addition to causing patient discomfort and inconvenience, those protocols and extended hospital stays add to the expense of postoperative care. Indeed, it is currently estimated that postoperative GII add \$2.7 billion in costs to U.S. health care.
- 20 **[0004]** It is an understandable goal of the health care industry to determine which patients are at risk of GII prior to beginning oral re-feeding after surgery because early intervention or alteration of the re-feeding regimen may enable avoidance of the consequences of GII and could reduce costs. Unfortunately, no reliable method for determining which patients are physiologically at risk for GII in the early postoperative period is currently available.
- 25 **[0005]** US 2012/0156398 discloses a system and method for detecting a gastric motility dysfunction that acquires acoustic event information associated with a body and compares the acquired acoustic event information to information associated with a healthy condition. The system and method then identifies the gastric motility dysfunction based on the comparison of the acquired acoustic event information to the information associated with the healthy condition.
- 30 **[0006]** US 2008/306355 discloses a system and method for evaluating gastrointestinal motility and, optionally, other physiological characteristics (e.g., pulse rate) that can be effectively employed to acquire one or more signals associated with acoustic energy (i.e. sound) emanating from an abdominal region of a body and determine at least one gastrointestinal parameter or event based on the acoustic energy signal(s). The gastrointestinal parameter can include a gastrointestinal event, including gastrointestinal mixing, emptying, contraction and propulsion, and gastrointestinal transit time, or a gastrointestinal system disorder, including reflux disease, irritable bowel disease, ulcerative colitis, constipation, diarrhea, and a migrating motor complex disorder.
- 35 **[0007]** According to one aspect, the present invention provides a system configured to predict gastrointestinal impairment as set out in the appended claim.

Brief Description of the Drawings

- 40 **[0008]** The present disclosure may be better understood with reference to the following figures. Matching reference numerals designate corresponding parts throughout the figures, which are not necessarily drawn to scale.

Fig. 1 is a schematic diagram that illustrates a first embodiment of a system for predicting gastrointestinal impairment

- 45 Fig. 2 is a schematic diagram that illustrates a second embodiment of a system for predicting gastrointestinal impairment.

Fig. 3 is a schematic diagram that illustrates a third embodiment of a system for predicting gastrointestinal impairment.

Fig. 4 is a schematic diagram that illustrates a fourth embodiment of a system for predicting gastrointestinal impairment.

- 50 Fig. 5 is a block diagram of an embodiment of the architecture of a device, such as one of those shown in Figs. 1-4, that can process collected patient data to assist in the gastrointestinal impairment predication.

Fig. 6 is a flow diagram of an embodiment of a method for predicting gastrointestinal impairment.

Fig. 7 is an example spectrogram illustrating spectral events contained in recorded abdominal sounds.

- 55 Fig. 8 is a graph that plots temporal changes in a particular spectral event (MH4) in patients with and without gastrointestinal impairment.

Detailed Description

- [0009]** As described above, gastrointestinal impairment (GII) is common following surgical procedures. Unfortunately,

no reliable method for determining which patients are at risk for GII is currently available. Disclosed herein are systems and methods for predicting GII based upon the patient's intestinal sounds. As is described below, the disclosed systems and methods identify discrete acoustic spectral events within the intestinal sounds, which can be used to predict subsequent GII. Those spectral events are good indicators of intestinal tract function because the sounds are produced by motor activity within the bowel.

[0010] In the following disclosure, various embodiments are described. It is to be understood that those embodiments are mere example implementations of the inventions and that other embodiments are possible. All such other embodiments are intended to fall within the scope of this disclosure.

[0011] The invention is defined by the appended claims.

[0012] Fig. 1 illustrates a first example system 10 for predicting gastrointestinal impairment. As is indicated in Fig. 1, the system 10 generally comprises a data collection device 12, a patient interface 14, and a computer 16. The data collection device 12 can comprise any device that is capable of collecting audio data that is generated within a patient's intestinal tract. In some embodiments, the data collection device 12 comprises a portable (e.g., handheld) digital audio recorder. In such a case, the data collection device 12 can comprise an integral microphone (not shown) that is used to capture the intestinal sounds.

[0013] The patient interface 14 is a device that can be directly applied to the patient's abdomen for the purpose of picking up intestinal sounds. In some embodiments, the patient interface 14 comprises, or is similar in design and function to, a stethoscope head. Stethoscope heads comprise a diaphragm that is placed in contact with the patient and that vibrates in response sounds generated within the body. Those sounds can be delivered to the microphone of the data collection device 12 via tubing 18 that extends between the patient interface 14 and the data collection device. Specifically, acoustic pressure waves created from the diaphragm vibrations travel within an inner lumen of the tubing 18 to the microphone. In some embodiments, all or part of the patient interface 14 is disposable to avoid cross-contamination between patients. Alternatively, the patient interface 14 can be used with a disposable sheath or cover (not shown) that can be discarded after use.

[0014] The audio data collected by the data collection device 12 can be stored within internal memory of the device. For example, the audio data can be stored within nonvolatile memory (e.g., flash memory) of the device 12. That data can then be transmitted to the computer 16 for processing. In some embodiments, the data is transmitted via a wire or cable 20 that is used to physically connect the data collection device 12 to the computer 16. In other embodiments, the data can be wirelessly transmitted from the data collection device 12 to the computer 16 using a suitable wireless protocol such as Bluetooth or Wi-Fi (IEEE 802.11).

[0015] The computer 16 can, in some embodiments, comprise a desktop computer. It is noted, however, that substantially any computing device that is capable of receiving and processing the audio data collected by the data collection device 12 can be used. Therefore, the computer 16 can, alternatively, take the form of a mobile computer, such as a notebook computer, a tablet computer, or a handheld computer. It is further noted that, although the data collection device 12 and the computer 16 are illustrated in Fig. 1 as comprising separate devices, they can instead be integrated into a single device, for example a portable (e.g., handheld) computing device. For example, the data collection device 12 can be provided with a digital signal processor and appropriate software/firmware that can be used to analyze the collected audio data.

[0016] Fig. 2 illustrates a second example system 24 for predicting gastrointestinal impairment. As indicated in Fig. 2, the system 24 shares several similarities with the system 10 illustrated in Fig. 1. Therefore, the system 24 generally comprises a data collection device 26, a patient interface 28, and a computer 30. In the system 24 of Fig. 2, however, the patient interface 28 comprises a device having its own integral microphone (not shown). In such a case, patient sounds are picked up by the microphone of the patient interface 28 and are converted into electrical signals that are electronically transmitted along a wire or cable 32 to the data collection device 26 for storage and/or processing. Alternatively, the patient sounds can be transmitted to the data collection device 26 wirelessly. In some embodiments, the patient interface 28 has an adhesive surface 36 that enables the interface to be temporarily adhered to the patient's skin in similar manner to an electrocardiogram (EKG) lead. As with the previous embodiment, patient data can be transmitted from the data collection device 26 to the computer 30 via a wired connection (via wire or cable 34) or wirelessly.

[0017] Fig. 3 illustrates a third example system 40 for predicting gastrointestinal impairment. The system 40 comprises a patient interface 42 and a data collection device 44. As with the system 24 of Fig. 2, the patient interface 42 can comprise a device having its own integral microphone (not shown) and patient sounds picked up by the microphone can be electronically transmitted along a wire or cable 46 to the data collection device 44. In the embodiment of Fig. 3, however, the data collection device 44 comprises a component that is designed to dock with a patient monitoring system 48, which may be located beside the patient's bed. Such patient monitoring systems 48 are currently used to monitor other patient parameters, such as blood pressure and oxygen saturation. In the example of Fig. 3, the patient monitoring system 48 comprises a docking station 50 and an associated display 52. In such a case, the data collection device 44 can dock within a free bay 54 of the station prior to use.

[0018] In some embodiments, the data collection device 44 comprises no internal power supply and therefore can

only collect patient data when docked. By way of example, the data collection device 44 can have electrical pins (not shown) that electrically couple the device to the patient monitoring system 48 for purposes of receiving power and transferring collected data to the patient monitoring system. The patient data can then be stored in memory of the patient monitoring system 48 and/or can be transmitted to a central computer for storage in association with a patient record in an associated medical records database.

[0019] As is further shown in Fig. 3, the data collection device 44 comprises an electrical port 56 that can receive a plug 58 of the wire or cable 46. In addition, the data collection device 44 can comprise one or more indicators 60, such as light-emitting diode (LED) indicators that convey information to the operator, such as positive electrical connection with the patient monitoring system 48 and patient signal quality.

[0020] Fig. 4 illustrates a fourth example system 62 for predicting gastrointestinal impairment. Like the system 40 of Fig. 3, the system 62 comprises a data collection device 64 that couples with a patient monitoring system 66. However, instead of an external patient interface, the system 62 comprises an internal patient interface 68 that is designed to collect sounds from within the peritoneal cavity. By way of example, the patient interface 68 comprises a small diameter microphone catheter that is left in place after surgery has been completed, in similar manner to a drainage catheter. Such a patient interface may be particularly useful in cases in which the patient is obese and it is more difficult to obtain high-quality signals from the surface of the skin. To avoid passing current into the patient, the patient interface 68 can comprise a laser microphone. In such a case, a laser beam is directed through the catheter and reflects off a target within the body. The reflected light signal is received by a receiver that converts the light signal to an audio signal. Minute differences in the distance traveled by the light as it reflects from the target are detected interferometrically. In alternative embodiments, the patient interface 68 can comprise a microphone that is positioned at the tip of the catheter.

[0021] As described above, Figs. 1-4 illustrate four different example embodiments of a system for predicting gastrointestinal impairment. It is noted that combinations of those systems are possible. For instance, the user interface 68 shown in Fig. 4 could be used with the data collection device 12 of Fig. 1, if desired. All such combinations are considered to be within the scope of this disclosure.

[0022] Fig. 5 illustrates an example architecture for a device 72 that can be used in a system for predicting gastrointestinal impairment to analyze collected patient data. By way of example, the architecture shown in Fig. 5 can be the architecture of the computer 16 or 30 shown in Figs. 1 and 2 respectively, the data collection device 12, 26, 44, or 64 shown in Figs. 1, 2, 3, and 4 respectively, or the patient monitoring system 48 or 66 shown in Figs. 3 and 4 respectively. Moreover, it is noted that the illustrated architecture can be distributed across one or more devices.

[0023] As is indicated in Fig. 5, the device 72 generally comprises a processing device 74, memory 76, a user interface 78, and input/output devices 80, each of which is coupled to a local interface 82, such as a local bus.

[0024] The processing device 74 can include a central processing unit (CPU) or other processing device, such as a microprocessor or digital signal processor. The memory 76 includes any one of or a combination of volatile memory elements (e.g., RAM) and nonvolatile memory elements (e.g., flash, hard disk, ROM).

[0025] The user interface 78 comprises the components with which a user interacts with the device 72. The user interface 78 can comprise, for example, a keyboard, mouse, and a display device, such as a liquid crystal display (LCD). Alternatively or in addition, the user interface 78 can comprise one or more buttons and/or a touch screen. The one or more I/O devices 80 are adapted to facilitate communication with other devices and may include one or more electrical connectors and a wireless transmitter and/or receiver. In addition, in cases in which the device 72 is the data collection device, the I/O devices 80 can comprise a microphone 84.

[0026] The memory 76 is a computer-readable medium and stores various programs (i.e., logic), including an operating system 86 and an intestinal sound analyzer 88. The operating system 86 controls the execution of other programs and provides scheduling, input-output control, file and data management, memory management, and communication control and related services. The intestinal sound analyzer 88 comprises one or more algorithms that are configured to analyze intestinal audio data for the purpose of predicting the likelihood of a patient developing GII. In some embodiments, the analyzer 88 conducts that analysis relative to correlation data stored in a database 90 and presents to the user (e.g., physician or hospital staff) a predictive index of GII risk. In some embodiments, the analyzer 88 identifies particular spectral events of interest using target signal parameters, signal-to-noise ratio parameters, and noise power estimation parameters. Decision tree analysis of the number of predictive spectral events during a specified time interval can then be used to communicate a high-, intermediate-, or low-risk of GII. In some embodiments, the risk associated with each level of risk is 83%, 30%, and 0%, respectively.

[0027] Fig. 6 illustrates an embodiment of a method for predicting GII. Beginning with block 100, patient intestinal sounds are recorded to generate an audio data. As described above, the sounds can be obtained non-invasively, for example using a stethoscope head or other patient interface that is applied to the patient's skin on or near the abdomen. Alternatively, the sounds can be collected with a device that extends into the patient's peritoneal cavity. The sounds can be recorded early in the postoperative period, for example the day of or a day immediately following surgery. Regardless of when the sounds are recorded, they are recorded for a duration of time that is sufficient to enable identification of spectral events that are predictive of intestinal function. By way of example, sounds are recorded for a period of approx-

imately 4 to 6 minutes. In some embodiments, all sounds within the 20-20,000 Hz range are recorded. Filters can be applied, however, to reduce the range of frequencies that are recorded, and therefore reduce the amount of data that is analyzed. In some embodiments, filters are used so that only sounds with frequencies from approximately 700 to 1500 Hz are recorded or analyzed. Although the sounds have been described as being "recorded," it will be understood that the sounds can alternatively simply be obtained and real-time processed (as described below) without actually recording the sounds.

[0028] Once the audio data is generated, the data is processed, for example in real time, to identify one or more predictive spectral signals, as indicated in block 102. As described above, the sounds that are generated by the intestines are the result of peristalsis. The sounds therefore provide an indication of how the bowels are functioning. For example, paralysis of significant portions of the intestinal tract will proportionally reduce the number of high-energy propulsive contractions in the gut, which results in the loss of some of the higher energy, and thus higher frequency, acoustic spectrum that is typical with normally functioning bowels. As described below, it has been determined that certain predefined spectral events can be identified within the sounds that are highly predictive of whether GII is or is not likely to occur. As is also described below, each of the predefined spectral events is defined by particular characteristics or parameters, such as their frequency, amplitude, duration, and separation in time from other spectral events.

[0029] After the spectral events have been identified, their number during a specified duration of time (e.g., the total duration of the recording) are totaled, as indicated in block 104. At this point, the total number of spectral events is compared to correlation data that correlates the number of spectral events with the likelihood of later GII, as indicated in block 106. As an example, a spectral event designated as "MH4" was identified in a study described below. With MH4, a high risk of GII exists if the number of observed MH4 events is less than approximately 21 times during four minutes of recording, an intermediate risk of GII exists if the number of observed MH4 events is greater than approximately 21 but less than approximately 131 times during four minutes of recording, and a low risk of GII exists if the number of observed MH4 events is greater than approximately 131 times during four minutes of recording. The number of predefined spectral events therefore can be used as an index that conveys the magnitude of the risk for GII, with a lower number indicating greater risk and a higher number indicating lower risk.

[0030] Once the likelihood of later GII has been determined, that risk can be conveyed to the user, as indicated in block 108. For example, the computer or other device used to perform the analysis can display the risk level on an associated display. In some embodiments, the risk can be conveyed as an index (i.e., a number). In other embodiments, the risk can be indicated as being "high," "moderate," or "low." Regardless, appropriate action can then be taken relative to the indication and may comprise permitting or prohibiting oral feeding. Notably, further recordings and analysis can be performed on the patient in the ensuing days after surgery to evaluate bowel function and confirm the initial patient assessment.

[0031] As can be appreciated from the above-described method, the risk of GII can be assessed much in the same way that the risk of heart problems can be non-invasively assessed with an EKG. In some embodiments, the risk assessment can be performed real-time.

[0032] A clinical study was performed to evaluate the viability of the disclosed systems and methods. One goal of the study was to confirm that spectral events present in intestinal sounds early in postoperative period do in fact correlate with GII subsequently, before clinical signs and symptoms develop. Another goal of the study was to develop a model for predicting GII that can be implemented as a simple, noninvasive, point-of-care test that will enable hospitals and other institutions to risk stratify patients for development of clinically significant GII using analysis of intestinal sounds.

[0033] In the study, patients who were scheduled to undergo inpatient surgery were recruited using an IRB-approved protocol. Patients undergoing abdominal and non-abdominal surgeries were included. Those who were admitted to the ICU postoperatively were excluded from the remainder of the study.

[0034] A device for digitally recording abdominal sounds was assembled using a dual-channel digital audio recorder (Microtrak II, M-Audio Corp., Irwindale, CA), condenser microphone (ATR35s, Audio-Technica Ltd, Leeds, UK), stethoscope tubing, and stethoscope heads. For recording intestinal sounds, the stethoscope heads were applied to the upper and lower anterior abdominal wall and both channels were recorded simultaneously for a period of 5-6 minutes. A standardized tone was also applied to each recording to calibrate audio levels.

[0035] Recordings of intestinal sounds were performed by the research team immediately preoperatively and then on each postoperative day. The research team also collected clinical outcome data on a daily basis. Variables related to the development of GII are shown in Table 1. The clinical team providing patient care was blinded to the results of the audio recordings.

Table 1. Clinical variables collected daily related to presence of GII.

Diet Started
Diet Type

(continued)

Hours since last meal
Abdominal Distension Present
Emesis
Flatus
Bowel movement
Reversal of diet
Motility agent prescribed
Toleration of diet for 24h

[0036] Audio recordings were subsequently processed using digital signal processing algorithms. The algorithms were applied in an iterative fashion focusing on identifying spectral events preoperatively or in the early postoperative period that would predict the development of GII during the remainder of the hospital stay. Five types of spectral events that span different portions of the audible spectrum were ultimately used for the analyses. Each type of spectral event was defined by unique target signal parameters (minimum and maximum frequency, minimum and maximum duration, and minimum separation), signal-to-noise ratio parameters (minimum occupancy, signal-to-noise threshold), and noise power estimation parameters (block size, hop size, percentile). The five spectral events were designated H4, M4, L4, ML4, and MH4, and the parameters for each are shown in Table 2. Spectral events were counted over a four-minute interval of time. GII was defined as the presence of emesis, the need for nasogastric intubation, or the reversal of the diet.

Table 2. Detector settings for the defined spectral events.

Event Name	Target Signal Parameters					Signal-to-Noise Ratio Parameters		Noise Power Estimation Parameters		
	Min. Freq. (hz)	Max. Freq. (hz)	Min. Dur. (ms)	Max. Dur. (ms)	Min. Sep. (ms)	Min. Occupancy (%)	SNR Threshold (dB)	Block Size (ms)	Hop Size (ms)	Percentile (%)
L4	20	400	23	600	11.6	66	10.0	1004	499	15.0
M4	400	1400	23	600	29	67	10.0	1497	499	20.0
H4	1400	20000	5.8	600	20	70	10.0	1198	600	20.0
ML4	400	900	5.8	600	20	70	10.0	1198	600	20.0
MH4	900	20000	5.8	600	20	70	10.0	1198	600	20.0

[0037] RavenPro 1.4 software was used for visualization, analysis, and measurement of the recorded audio signals. Statistical analyses were performed using PASW 18 and Clementine 10.1.

[0038] Thirty-seven patients were recruited into the study. Five patients were excluded due to admission to the ICU postoperatively. Two patients discharged on the day of operation were excluded as no postoperative data was acquired. Of the remaining thirty patients, eleven were male and nineteen were female. The mean age was 52 (SD=12). Five patients had extra-abdominal operations and twenty-five patients had intra-abdominal operations. Nine patients (30% of the total) subsequently developed GII, all within the first four postoperative days. Of those patients, four began on POD1, one on POD2, and four on POD4.

[0039] Examples of three of the spectral events are shown in a spectrogram of Fig. 7. The mean number of spectral events of each designation was calculated for patients who did or did not subsequently exhibit GII. A two-tailed t-test was then used to assess the significance of any differences. Spectral events obtained from PODO did not correlate with subsequent development of GII (Table 3). Spectral events obtained from POD1, however, did prove to correlate with subsequent development of GII (Table 4). Specifically, MH4 spectral events had a mean count of 154 in patients without subsequent GII and 44 in those who did develop GII (p=.004).

EP 2 557 988 B1

Table 3. Correlation of PODO spectral events with development of GII.

		PODO		
Spectral Event	Postop GII	N	Mean Count	2-tailed t-test
L4	No	21	3357	.55
	Yes	9	3247	
M4	No	21	216	0.80
	Yes	9	232	
H4	No	21	32	.37
	Yes	9	45	
ML4	No	21	919	.84
	Yes	9	949	
MH4	No	21	268	.10
	Yes	9	398	

Table 4. Correlation of POD1 spectral events with development of GII.

		POD1		
Spectral Event	Postop GII	N	Mean Count	2-tailed t-test
L4	No	21	3690	.62
	Yes	9	3620	
M4	No	21	314	.08
	Yes	9	218	
H4	No	21	30	.09
	Yes	9	9	
ML4	No	21	1234	.51
	Yes	9	1128	
MH4	No	21	154	.004
	Yes	9	44	

[0040] CHAID decision-tree analysis was then applied to develop a predictive model using this data as a training data set. Using CHAID analysis, two cut-off values for MH4 (at 21 and 131) were determined as measured on POD1 that could stratify the data set into low risk, intermediate risk, and high risk for subsequent GII (Table 5).

Table 5. Risk strata proposed based upon POD1 measurements of MH4.

Risk Strata	n	MH4 POD1	Risk of Subsequent GII
Low Risk	12	>131	0%
Intermediate Risk	12	21-131	30%
High Risk	6	<21	83%

[0041] The mean temporal changes in MH4 were examined in patients with and without GII. Fig. 8 is a graph that plots temporal changes in MH4 spectral events.

[0042] The results of the study confirmed that spectral events present in intestinal sounds early in the surgical stay do in fact correlate with GII before clinical signs and symptoms develop. In particular, it was determined that MH4 segregated highly and significantly with the presence of subsequent GII. A predictive model based on MH4 measurement therefore can be used to evaluate patients as being of high-, intermediate-, and low-risk for GII. Significantly, no patients in the low-risk group developed GII. In the study, the predictive value of low-risk classification for no GII was 100%, while

the predictive value of high-risk classification for GII was 83%. Thirty percent (30%) of the intermediate-risk patients experienced GII.

[0043] It is believed that powerful models can be generated from a larger data set of patients and by monitoring intestinal sounds during extended periods of time, such as a 24-hour period. Continuous recording with data averaging and adding additional types of spectral analysis may improve the predictive accuracy of the disclosed technique. Future trials are anticipated that will focus on gathering larger sets of data, validating the proposed predictive model, refining the spectral events analyzed, assessing alternate timings of data collection, and developing widely applicable predictive models. In addition, further development of reliable technology for rapid, point-of-care data continuous acquisition and analysis will be invaluable in expanding these investigations and ultimately in any clinical use. Regardless, the above-described study confirms the feasibility and promise of using acoustic spectral analysis in the study of GII and other gastrointestinal disorders.

Claims

1. A system configured to predict gastrointestinal impairment, the system (100) comprising:

an audio data collection device (76, 80) configured to collect audio data wherein the audio data comprises intestinal sounds collected from a patient after a surgical procedure,

a computer device (72) configured to receive and process the audio data,

wherein the audio data is obtained before clinical signs and symptoms of a gastrointestinal impairment develop, wherein the computer device (72) is configured to compare the processed audio data to identified spectral events being defined by predefined parameters and predictive of subsequent gastrointestinal impairment,

wherein the predefined parameters include: i) frequency of the predefined spectral event and the frequency is in the range of approximately 900 to 20,000 Hertz; ii) duration of the predefined spectral event and the duration is in the range of approximately 5 to 600 milliseconds; iii) minimum separation in time of the predefined spectral event from other spectral events and the minimum separation in time is approximately 20 milliseconds; iv) signal-to-noise ratio occupancy that is greater than about 70%; v) signal-to-noise ratio threshold of approximately 10 decibels; vii) noise power estimation parameters including a block size of 1198 milliseconds, a hop size of 600 and a percentile of 20%;

wherein the intestinal sounds are collected on the first post-operative day; and

wherein the computer device (72) is further configured to predict the likelihood of subsequent gastrointestinal impairment based on the comparison of the processed audio data to the identified spectral events.

Patentansprüche

1. System, das dazu konfiguriert ist, eine Magen-Darm-Beeinträchtigung vorherzusagen, wobei das System (100) umfasst:

eine Audiodatensammelvorrichtung (76, 80), die dazu konfiguriert ist, Audiodaten zu sammeln, wobei die Audiodaten Darmgeräusche umfassen, die von einem Patienten nach einem chirurgischen Eingriff gesammelt werden,

eine Computervorrichtung (72), die dazu konfiguriert ist, die Audiodaten zu empfangen und zu verarbeiten, wobei die Audiodaten erhalten werden, bevor sich klinische Anzeichen und Symptome einer Magen-Darm-Beeinträchtigung entwickeln,

wobei die Computervorrichtung (72) dazu konfiguriert ist, die verarbeiteten Audiodaten mit identifizierten Spektralereignissen zu vergleichen, die durch vordefinierte Parameter definiert sind und eine anschließende Magen-Darm-Beeinträchtigung vorhersagen,

wobei die vordefinierten Parameter beinhalten: i) eine Frequenz des vordefinierten Spektralereignisses, und wobei die Frequenz im Bereich von ungefähr 900 bis 20.000 Hertz liegt; ii) eine Dauer des vordefinierten Spektralereignisses, und wobei die Dauer im Bereich von ungefähr 5 bis 600 Millisekunden liegt; iii) eine zeitliche Mindesttrennung des vordefinierten Spektralereignisses von anderen Spektralereignissen, und wobei die zeitliche Mindesttrennung ungefähr 20 Millisekunden beträgt; iv) eine Signal-Rauschabstandsbelegung, die höher als etwa 70 % ist; v) eine Signal-Rauschabstandsschwelle von ungefähr 10 Dezibel; vii) Rauschleistungsparameter, die eine Blockgröße von 1198 Millisekunden, eine Hop-Größe von 600 und ein Perzentil von 20 % beinhalten;

wobei die Darmgeräusche am ersten Tag nach der Operation gesammelt werden, und

wobei die Computervorrichtung (72) weiterhin dazu konfiguriert ist, die Wahrscheinlichkeit einer anschließenden Magen-Darm-Beeinträchtigung auf der Basis des Vergleichs der verarbeiteten Audiodaten mit den identifizierten Spektralereignissen vorherzusagen.

5

Revendications

1. Système configuré pour prédire un dysfonctionnement gastro-intestinal, le système (100) comprenant :

10 un dispositif de collecte de données audio (76, 80) configuré pour collecter des données audio dans lequel les données audio comprennent des sons intestinaux collectés chez un patient après une procédure chirurgicale, un dispositif d'ordinateur (72) configuré pour recevoir et traiter les données audio, dans lequel les données audio sont obtenues avant que des signes cliniques et des symptômes d'un dysfonctionnement gastro-intestinal ne se développent,

15 dans lequel le dispositif d'ordinateur (72) est configuré pour comparer les données audio traitées avec des événements spectraux identifiés étant définis par des paramètres prédéfinis et prédictifs d'un dysfonctionnement gastro-intestinal à venir, dans lequel les paramètres prédéfinis incluent : i) la fréquence de l'événement spectral prédéfini et la fréquence est comprise dans la plage d'approximativement 900 à 20 000 hertz ; ii) la durée de l'événement spectral prédéfini et la durée est comprise dans la plage d'approximativement 5 à 600 millisecondes ; iii) la séparation minimale en temps entre l'événement spectral prédéfini et les autres événements spectraux et la séparation minimale en temps est d'approximativement 20 millisecondes ; iv) une occupation de rapport de signal sur bruit qui est supérieure à environ 70 % ; v) un seuil de rapport de signal sur bruit d'approximativement 10 décibels ;

20 vii) des paramètres d'estimation de puissance de bruit incluant une taille de bloc de 1 198 millisecondes, une taille de saut de 600 et un centile de 20 % ;

25 dans lequel les sons intestinaux sont collectés le premier jour après l'opération ; et dans lequel le dispositif d'ordinateur (72) est configuré en outre pour prédire la probabilité d'un dysfonctionnement gastro-intestinal à venir sur la base de la comparaison des données audio traitées avec les événements spectraux identifiés.

30

35

40

45

50

55

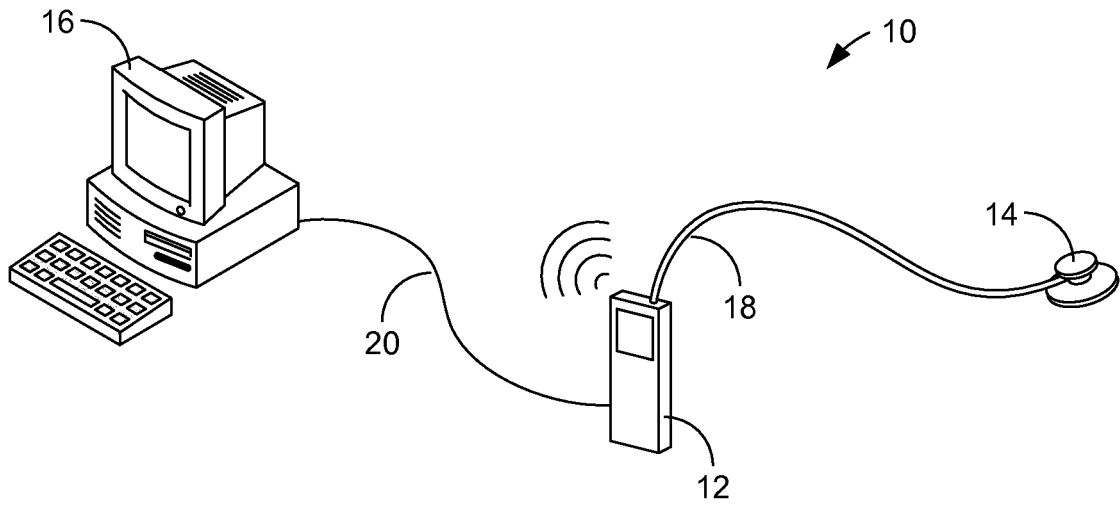

FIG. 1

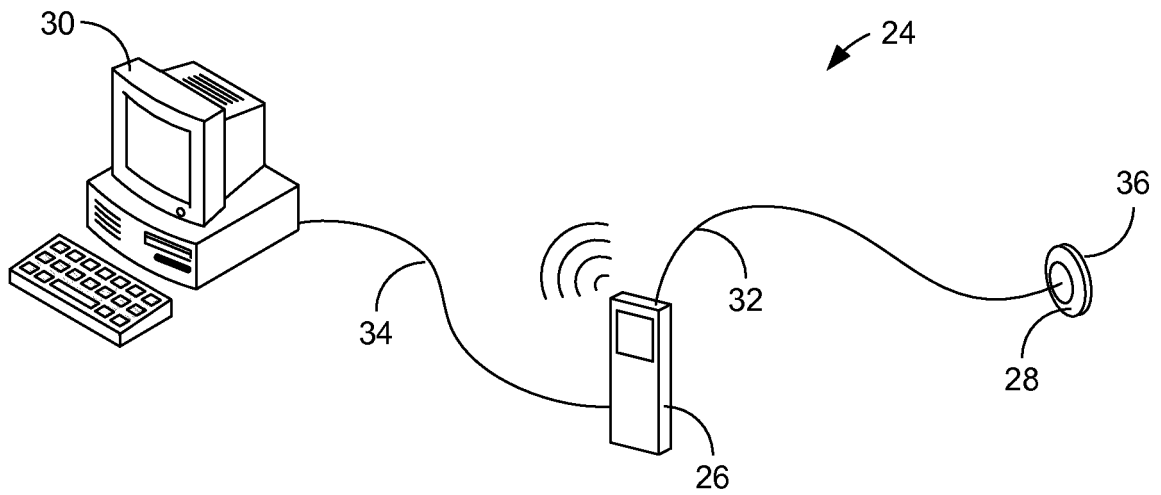

FIG. 2

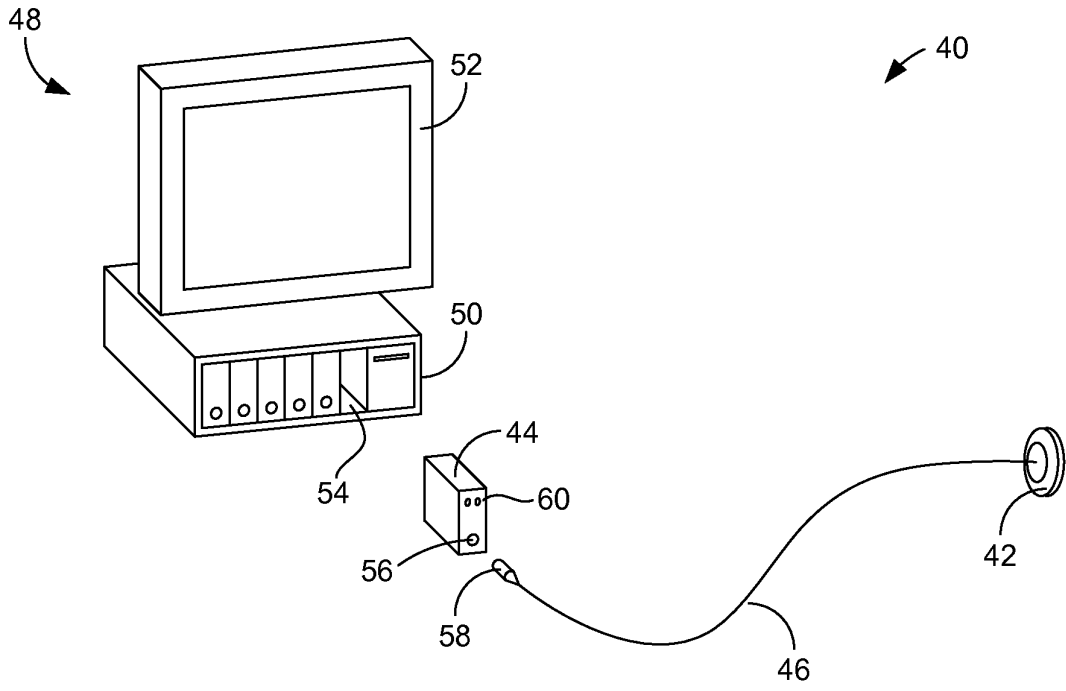

FIG. 3

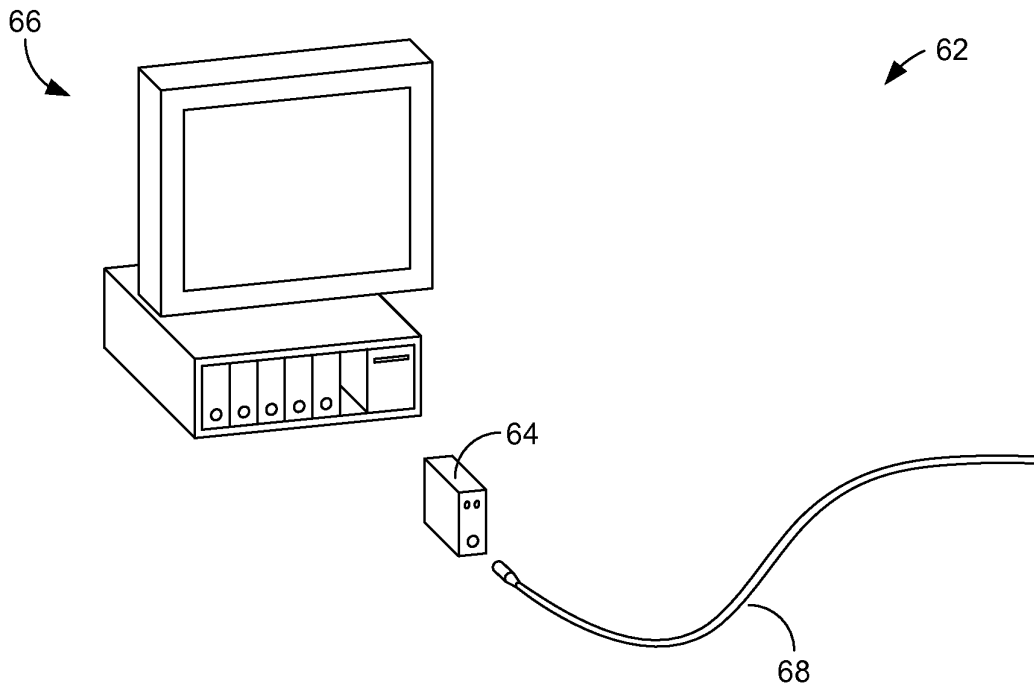

FIG. 4

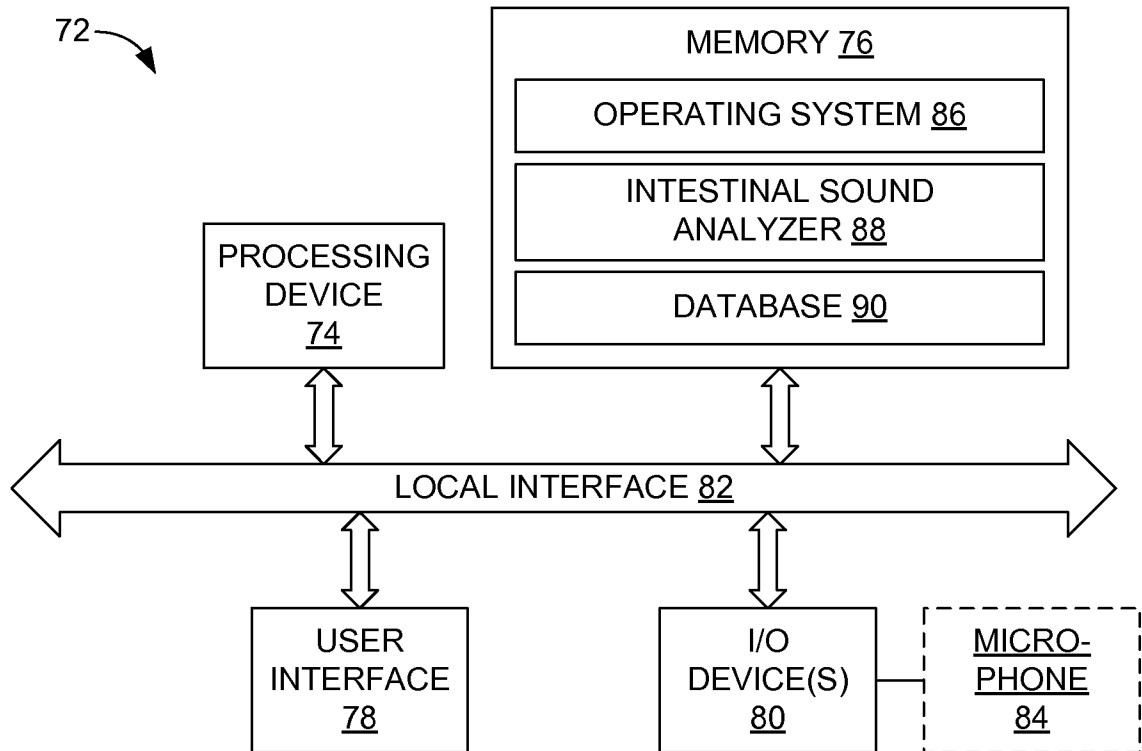

FIG. 5

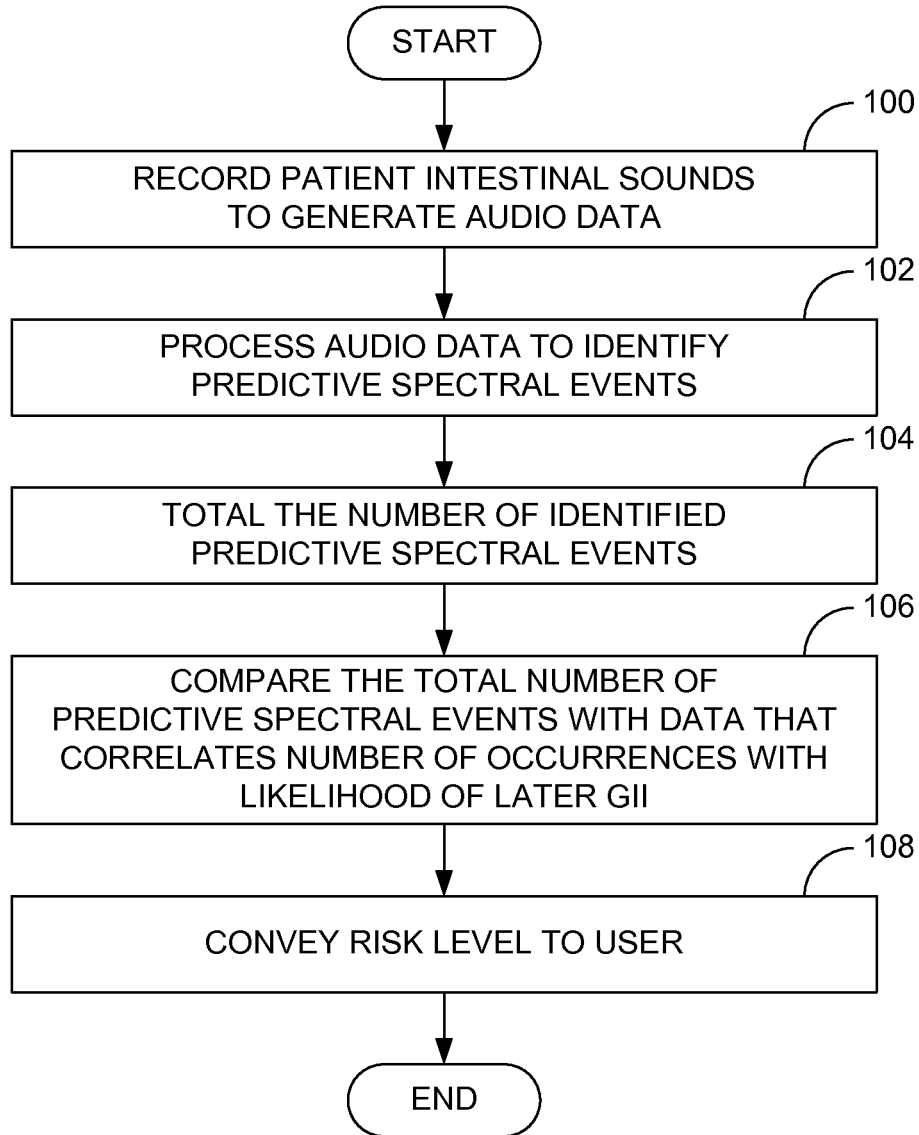

FIG. 6

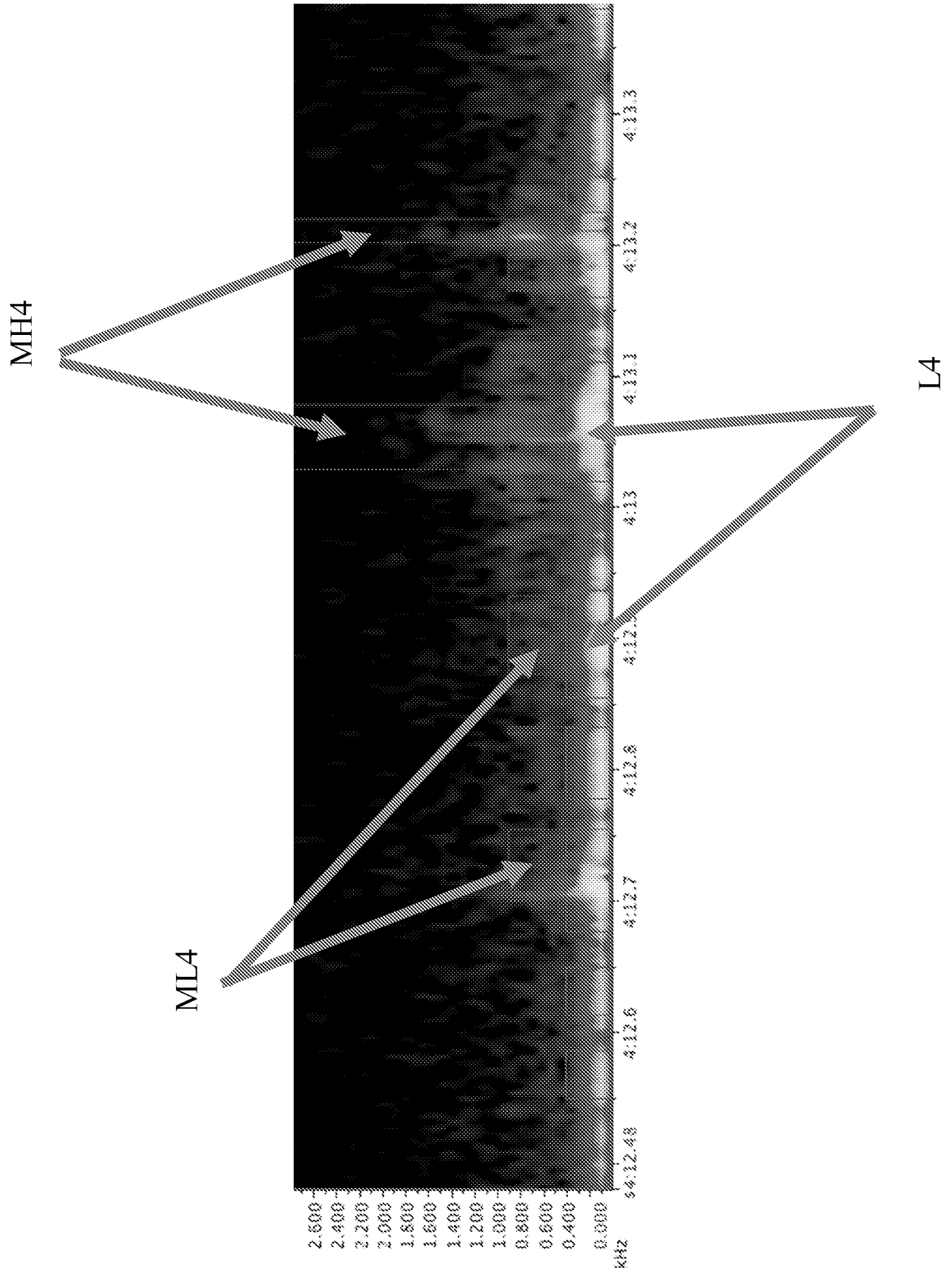

FIG. 7

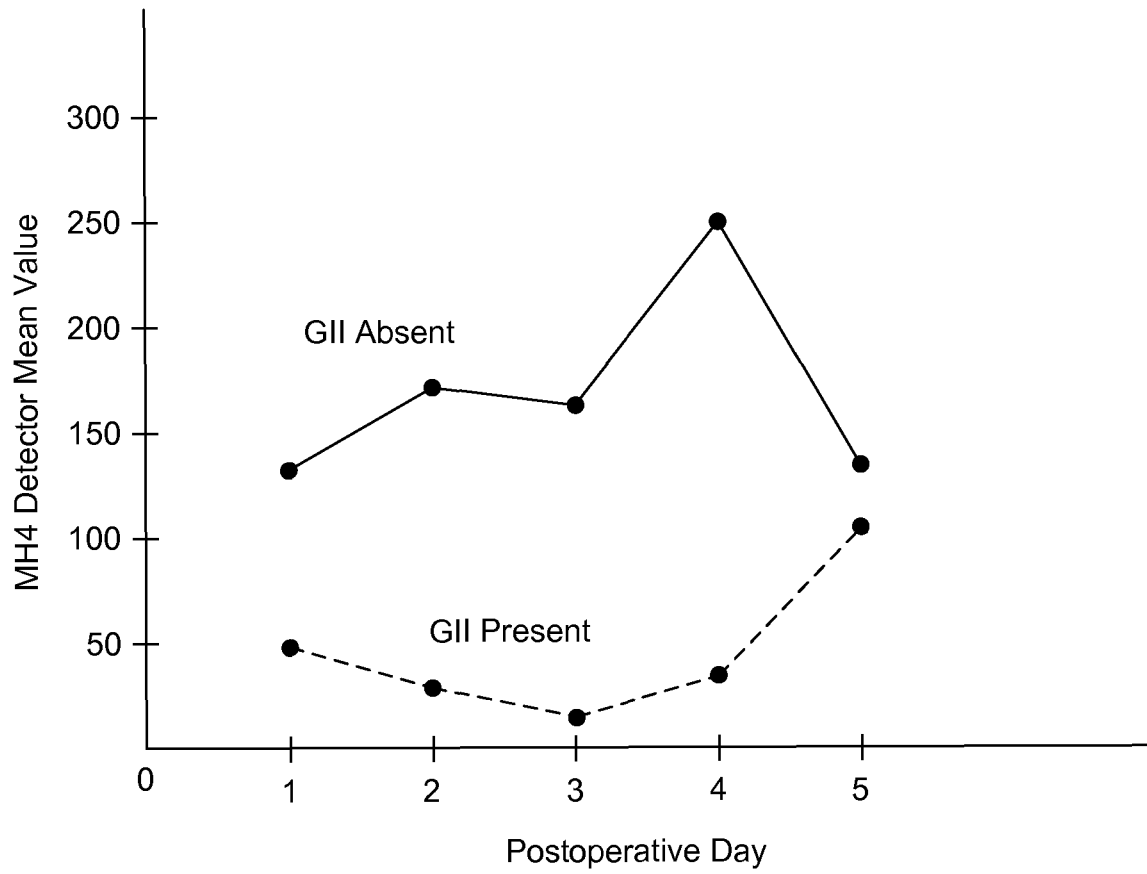

FIG. 8

REFERENCES CITED IN THE DESCRIPTION

This list of references cited by the applicant is for the reader's convenience only. It does not form part of the European patent document. Even though great care has been taken in compiling the references, errors or omissions cannot be excluded and the EPO disclaims all liability in this regard.

Patent documents cited in the description

- US 61324879 [0001]
- US 20120156398 A [0005]
- US 2008306355 A [0006]

专利名称(译)	胃肠道疾病预测系统		
公开(公告)号	EP2557988B1	公开(公告)日	2020-06-24
申请号	EP2011769638	申请日	2011-04-15
[标]申请(专利权)人(译)	田纳西大学研究基金会		
申请(专利权)人(译)	田纳西州研究基金会大学		
当前申请(专利权)人(译)	田纳西州研究基金会大学		
[标]发明人	CROMWELL JOHN W		
发明人	CROMWELL, JOHN, W.		
IPC分类号	A61B7/00 G16H50/30 G16H50/70 G16H50/20 A61B5/00 A61B7/04		
CPC分类号	A61B5/4255 A61B5/6823 A61B5/7275 A61B7/008 A61B2560/0456 G16H50/20 G16H50/30 G16H50/70		
优先权	61/324879 2010-04-16 US		
其他公开文献	EP2557988A4 EP2557988A2		
外部链接	Espacenet		

摘要(译)

预测胃肠道功能障碍可能涉及获取患者的肠道声音以生成音频数据，在音频数据中识别可预测后续胃肠道功能障碍的预定义频谱事件，频谱事件由预定义参数定义，以及预测后续胃肠道功能障碍相对的可能性识别的光谱事件。

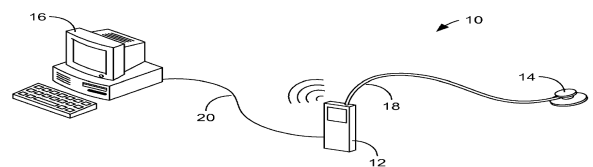

FIG. 1

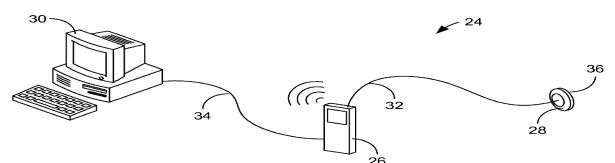

FIG. 2