

(19)



(11)

**EP 1 982 636 B2**

(12)

**NEW EUROPEAN PATENT SPECIFICATION**

After opposition procedure

(45) Date of publication and mention of the opposition decision:  
**07.09.2016 Bulletin 2016/36**

(51) Int Cl.:  
**A61B 1/00** <sup>(2006.01)</sup> **A61B 5/00** <sup>(2006.01)</sup>  
**H05K 1/00** <sup>(2006.01)</sup>

(45) Mention of the grant of the patent:  
**22.02.2012 Bulletin 2012/08**

(21) Application number: **08161902.5**

(22) Date of filing: **18.06.2002**

(54) **In vivo sensing device with a circuit board having rigid sections and flexible sections**

In-Vivo-Sensorvorrichtung mit einer Leiterplatte aus starren und flexiblen Abschnitten

Dispositif de détection in vivo avec carte de circuit dotée de sections rigides et sections flexibles

(84) Designated Contracting States:  
**AT BE CH CY DE DK ES FI FR GB GR IE IT LI LU MC NL PT SE TR**

(30) Priority: **18.06.2001 US 298387 P**

(43) Date of publication of application:  
**22.10.2008 Bulletin 2008/43**

(62) Document number(s) of the earlier application(s) in accordance with Art. 76 EPC:  
**02738602.8 / 1 418 833**

(73) Proprietor: **Given Imaging Ltd.**  
**20692 Yoqneam (IL)**

(72) Inventor: **Avni, Dov**  
**34525, Haifa (IL)**

(74) Representative: **Hoffmann Eitle**  
**Patent- und Rechtsanwälte PartmbB**  
**Arabellastraße 30**  
**81925 München (DE)**

(56) References cited:  
**EP-A- 1 104 182 EP-A1- 0 667 115**  
**WO-A1-95//15060 JP-A- 2001 091 860**  
**US-A- 3 791 377 US-A- 4 741 327**  
**US-A- 4 803 992 US-A- 4 860 732**  
**US-A- 5 078 134 US-A- 5 121 297**  
**US-A- 5 807 266 US-A- 5 833 603**

- **WAYE J D: "THE DEVELOPMENT OF THE SWALLOWABLE VIDEO CAPSULE (M2A)" GASTROINTESTINAL ENDOSCOPY, ELSEVIER, NL, vol. 52, no. 6, 1 December 2000 (2000-12-01), pages 817-819, XP008041293 ISSN: 0016-5107**
- **APPLEYARD\* ET AL: "A Randomized Trial Comparing Wireless Capsule Endoscopy With Push Enteroscopy for the Detection of Small-Bowel Lesions" GASTROENTEROLOGY, ELSEVIER, PHILADELPHIA, PA, vol. 119, no. 6, 1 December 2000 (2000-12-01), pages 1431-1438, XP005688749 ISSN: 0016-5085**

**EP 1 982 636 B2**

**Description****FIELD OF THE INVENTION**

[0001] The present invention relates to an in vivo imaging device and system such as for imaging the digestive tract.

**BACKGROUND OF THE INVENTION**

[0002] In vivo imaging may include the use of an in vivo imager from which image data may be transmitted to an external receiving system. For example, an ingestible capsule comprising an image sensor and a transmitter for transmitting image data may be used for imaging the gastrointestinal (GI) tract. In some ingestible capsules the electronic components within the capsule may be arranged on several boards, each board containing different components of the capsule, for example, the image sensor, typically a silicon chip, may be positioned on one board whereas the transmitter may be positioned on a separate printed circuit board (PCB). In some cases the boards are aligned along an axis of the capsule and are electrically connected by a plurality of wires. Assembly of capsules having several boards connected by wires may be complex and may hinder, for example, large scale production.

[0003] The report "The development of the swallowable video capsule (M2A)" by Gavriel D. Meron, Gastrointestinal endoscopy, vol. 52, no. 6, 2000, pages 817-819 describes the history of the development of a capsule endoscope at Given Imaging Limited. Among other things, it mentions the presentation of a capsule at the plenary session of the AGE on May 24, 2000.

[0004] The Article "A randomized trial comparing wireless capsule endoscopy with push enteroscopy for the detection of small-bowel lesions", by Mark Appleyard et al, Gastroenterology, 2000; vol. 119: 1431-1438 describes a capsule endoscope as well as results of using such a capsule endoscope.

[0005] US-3,791,377 describes a radio capsule battery in which a silver-silver chloride electrode functions as the reference electrode for a sensor by means of an electrolytic path from the battery chamber to the solution external to the capsule. The radio capsule comprises a battery chamber, a sensing electrode, an oscillator circuit, and an oscillator coil functioning as a transmitting antenna. The battery chamber is at one end of the capsule, and the coil is at the other. Between the battery chamber and coil two disks-shaped circuit boards are arranged, between which the oscillator circuit is provided. Furthermore, a silver wire that forms part of the silver-silver chloride electrode in the battery chamber extends through the first circuit board and contacts the other circuit board for forming an electrical connection between the two circuit boards.

[0006] US-4,803, 992 describes electro optical instruments, among them a medical instrument in the form of

a capsule to be ingested by swallowing and operable for sensing one or more physiological variables. The device includes electrical and optical means supported within a housing. Centrally supported across and between opposite wall portions of the housing is an electrical assembly including a circuit board defining a flat multilayer rectangular substrate containing a thin disk-shaped battery secured thereto, and connected for electrically energizing and powering circuit elements supported by the substrate.

[0007] EP-1 104 182 A1 describes an image sensor device for incorporation into endoscopes. More specifically, the document is specifically concerned with distal imaging endoscopes and the question of arranging an image sensor device in such an endoscope. According to the document, a printed circuit board is used that comprises rigid portions and flexible elements. The printed circuit board has one section carrying the imaging device, and a second section that is bent relative to the first section. The printed circuit board may be of "flex-rigid" type, i.e. a hybrid structure comprising rigid PCB portions and flexible elements where bends or creases are required.

**Summary of the invention**

[0008] JP 2001-091860A describes a capsule endoscope that comprises three subassemblies including a circuit board, a main block and an external case. The circuit board comprises three circular sections connected by strips and carries an image sensor, an image sensor control part and a transmission electric part. The main block comprises an illumination body support plate carrying LEDs and an objective lens holding cylinder carrying an objective lens. The external case contains the circuit board and main block in water-tight fashion.

[0009] In accordance with claim 1, the present application relates to an in-vivo sensing device in the form of a swallowable in-vivo sensing capsule that comprises a circuit board with a plurality of rigid sections connected by flexible sections, each of said rigid sections being connected by a flexible section of the circuit board, and with one or more batteries positioned between two rigid sections connected by a flexible section. The capsule further comprises an illumination source disposed on at least one rigid section of the circuit board. Advantageous embodiments are described in the dependent claims

[0010] Thus, the present invention provides, according to some embodiments an in vivo sensing device comprising a circuit board having a plurality of rigid sections and a plurality of flexible sections. According to one embodiment the rigid sections and flexible sections alternate. Optionally, the in vivo sensing device may include at least an image sensor. According to another embodiment the device may also include a transmitter for transmitting signals from a sensor, such as an imaging camera, to a receiving system. In one embodiment various components in the device, such as the image sensor and transmitter, are disposed on different rigid circuit board

sections. Preferably, the circuit board is folded and arranged in a stacked vertical fashion. In a further embodiment, the various rigid portions may be connected by vertical connectors such as springs.

### BRIEF DESCRIPTION OF THE DRAWINGS

**[0011]** The present invention will be understood and appreciated more fully from the following detailed description taken in conjunction with the drawings in which:

Figure 1 schematically illustrates an in vivo imaging device according to one embodiment of the invention;

Figures 2A and 2B schematically illustrate possible folding of the circuit board according to two embodiments of the invention; and

Figure 3 schematically illustrates an in vivo imaging device not falling under the claimed invention.

### DETAILED DESCRIPTION OF THE INVENTION

**[0012]** In the following description, various aspects of the present invention will be described. For purposes of explanation, specific configurations and details are set forth in order to provide a thorough understanding of the present invention. However, it will also be apparent to one skilled in the art that the present invention may be practiced without the specific details presented herein. Furthermore, well-known features may be omitted or simplified in order not to obscure the present invention.

**[0013]** The system and method of the present invention may be used with an imaging system such as that described in WO 01/65995. A further example of an imaging system with which the system and method of the present invention may be used is described in U.S. Patent No. 5,604,531 to Iddan et al. Both these publications are assigned to the common assignee of the present application and are hereby incorporated by reference. Alternatively, the system of the present invention may be utilized in any suitable imaging device providing images of a body lumen or cavity. For example, a circuit board according to an embodiment of the invention may be utilized in probes used for in vivo imaging, such as endoscopes.

**[0014]** Reference is now made to Fig. 1, which schematically illustrates an in vivo imaging device according to an embodiment of the invention. The device 10 typically comprises an optical window 21 and an imaging system for obtaining images from inside a body lumen, such as the GI tract. The imaging system includes an illumination source 23, such as a white LED, a CMOS imaging camera 24, which detects the images and an optical system 22 which focuses the images onto the CMOS image sensor 24. The illumination source 23 illuminates the inner portions of the body lumen through optical window 21. Device 10 further includes a transmit-

ter 26 and an antenna 27 for transmitting image signals from the CMOS image sensor 24, and a power source 25, such as a silver oxide battery, that provides power to the electrical elements of the device 10. A suitable CMOS image sensor 24 is, for example, a "camera on a chip" type CMOS imager specified by Given Imaging Ltd. of Yokneam, Israel and designed by Photobit Corporation of California, USA. The single chip camera can provide either black and white or color signals. A suitable transmitter may comprise a modulator which receives the image signal (either digital or analog) from the CMOS imaging camera, a radio frequency (RF) amplifier, an impedance matcher and an antenna. A processor, e.g., for processing the image data may be included in the device. The processor or processing circuitry may be integrated in the sensor or in the transmitter.

**[0015]** The device 10 is capsule shaped and can operate as an autonomous endoscope for imaging the GI tract. However, other devices, such as devices designed to be incorporated in an endoscope, catheter, stent, needle, etc., may also be used, according to embodiments of the invention. Furthermore, the device 10 need not include all the elements described above. For example, the device 10 need not include an internal light source or an internal power source; illumination and/or power may be provided from an external source, as known in the art.

**[0016]** According to one embodiment of the invention, the various components of the device 10 are disposed on a circuit board including rigid and flexible portions; preferably the components are arranged in a stacked vertical fashion. For example, one rigid portion 31 of the circuit board may hold a transmitter and an antenna; preferably the antenna is at one end of the capsule to avoid screening of the signal by metal or other components in the capsule. Another rigid portion 33 of the circuit board includes an LED 23 lighting system and an imager 24 on one side; the other side of this rigid portion 33 includes a battery 25 contact. The battery contact is preferably a spring, described below. Another rigid portion 35 of the circuit board includes another battery contact. Each rigid portion of the circuit board is connected to another rigid portion of the circuit board by a flexible connector portion (e.g. 32 and 32') of the circuit board. Preferably, each rigid portion of the circuit board comprises two rigid sections; sandwiched between the rigid sections is a flexible connector portion of the circuit board for connecting the rigid boards. In alternate embodiments, other arrangements of components may be placed on a circuit board having rigid portions connected by flexible portions.

**[0017]** In alternate embodiments, a circuit board having rigid portions and flexible portions may be used to arrange and hold components in other in vivo sensing devices, such as a swallowable capsule measuring acidity (having a pH sensor, temperature or pressure, or in a swallowable imaging capsule having components other than those described above.

**[0018]** Preferably, each flexible connector portion is

equal to or less than 4/1000 inch (4 mils) in thickness. Preferably, electrical connection is made from the outside portion of a rigid portion board (on which components are mounted) to the inside of the rigid portion and to the flexible portion contained within, by a small (equal to or less than 4 mils in diameter) hole leading from the outside portion to the flexible portion - a micro-via. Preferably the micro-via is created using a laser. Companies providing such flexible connector and micro-via technology are Eltech, of Petach-Tikva, Israel, and Ilfa, of Germany. In alternate embodiments, other types of rigid sections and flexible sections may be used to create a circuit board.

**[0019]** The circuit board may be folded, for example, as shown in Figs. 2A and 2B. When folded, the battery contacts contact a set of one or more batteries, which are sandwiched between two rigid circuit board portions. The circuit board may be folded in various manners. For example, Fig. 2A schematically shows a circuit board, according to an embodiment of the invention, arranged as an "S" with rigid portions 31,35 and 33 and alternating flexible portions 32 and 32'. A set of batteries 25 may be sandwiched between one lobe 38 of the S. Another configuration, according to an embodiment of the invention is schematically shown in Fig. 2B. The circuit board, according to an embodiment of the invention may be in the shape of a "6" with rigid portions 31,35 and 33 and alternating flexible portions 34 and 3,4. A set of batteries 25 may be positioned in the closed configuration 38' of the "6".. Other configurations are possible. In alternate embodiments, batteries may be connected in different manners, or need not be used.

**[0020]** Preferably, a verythin flexible section is needed due to the radius of the diameter of the turns, given the size of the capsule, and also because the flexible section may be disposed between components, such as between the set of batteries and the side of the capsule. Preferably, the radius of the turn should be more than 6 or 10 times the thickness. In alternate embodiments, the rigid boards and flexible connectors may be of other dimensions.

**[0021]** In one embodiment, the rigid portions of the circuit board may include any sort of known material; preferably FR4 flexiglass is used. The flexible portions may include any sort of known material; preferably, Kapton™ by DuPont is used.

**[0022]** Reference is made to Figure 3, which schematically illustrates another view of an example not falling under the invention as presently claimed. According to one example, a vertical physical and electrical connection may be made between rigid portions of the circuit board. For example, the rigid portion 51 holding the LED 23 (which is preferably in the shape of a ring) may be connected physically and electrically to another rigid portion apart from being connected by flexible portion 57. In one example, mini springs 56 are used to connect a power supply from one circuit rigid portion 53 to the rigid portion 51 holding the LED 23. Such springs 56 have two functions; to mechanically connect the two rigid portions

(e.g., 51 and 53) and also to conduct current between the two rigid portions. Preferably, the springs are glued to the two rigid portions, and current flows between two rigid portions.

**[0023]** In addition, a vertical connection is made between the set of batteries 25 and two rigid portions by springs 58. Each contact spring 58 is preferably a conical spring, which, as it shrinks, allows each circle or coil of the spring to enter a larger encircling coil. Thus, when fully shrunken, the final thickness of the spring is thickness of a single circle of conductor wire.

**[0024]** There is also provided a method for the manufacture of an in vivo sensor, in accordance with an embodiment of the invention. The method includes the steps of disposing at least a sensor on a rigid section of a circuit board having a plurality of rigid sections each connected by a flexible section of the circuit board and folding the circuit board into a housing configured for in vivo sensing.

**[0025]** It will be appreciated by persons skilled in the art that the present invention is not limited to what has been particularly shown and described hereinabove. Rather the scope of the present invention is defined only by the claims which follow:

## Claims

1. A swallowable in vivo sensing capsule (10) comprising:
  - a circuit board that comprises a plurality of rigid sections (31, 33, 35) connected by flexible sections, each of said rigid sections (33, 35) being connected by a flexible section (32, 32') of the circuit board, and one or more batteries (25) being positioned between two rigid sections connected by a flexible section, the swallowable in vivo sensing capsule further comprising an illumination source (23) disposed on at least one rigid section (33) of the circuit board.
2. The capsule according to claim 1, wherein said illumination source (23) comprises an LED lighting system.
3. The capsule according to one of claims 1 or 2, further comprising at least one component selected from the group consisting of a sensor (24), a processor, a transmitter (26) or a combination thereof.
4. The capsule according to claim 3 wherein at least one component is disposed on at least one rigid section of the circuit board.
5. The capsule according to claim 3 wherein a plurality of components are disposed on a plurality of rigid sections of the circuit board.

6. The capsule according to claim 3 wherein an image sensor is disposed on one rigid section of the circuit board and a transmitter is disposed on another rigid section of the circuit board.
7. The capsule of one of claims 1 to 6, wherein a plurality of flexible sections is provided, and the rigid sections alternate with the flexible sections.
8. The capsule according to one of claims 1 to 7, wherein the circuit board includes flexiglass.
9. A method for the manufacture of an in vivo capsule, the method comprising the steps of:
- disposing at least a sensor (24) and an illumination source (23) on one or more rigid sections (31, 33, 35) of a circuit board that comprises a plurality of rigid sections (31, 33, 35) each connected by a flexible section (32, 32') of the circuit board, and folding the circuit board into a housing configured for in vivo sensing, including positioning one or more batteries (25) between two of said rigid sections (33, 35) that are connected by a flexible section (32, 32').
10. The method according to claim 9, wherein the step of folding the circuit board includes folding the circuit board such that the rigid sections of the circuit board are stacked vertically.

#### Patentansprüche

1. Schluckbare In-vivo-Sensorkapsel (10), aufweisend:
- eine Leiterplatte, welche mehrere starre Abschnitte (31, 33, 35) aufweist, die durch flexible Abschnitte verbunden sind, wobei jeder der starren Abschnitte (33, 35) durch einen flexiblen Abschnitt (32, 32') der Leiterplatte verbunden ist und zwischen zwei starren Abschnitten, die durch einen flexiblen Abschnitt verbunden sind, eine oder mehrere Batterien (25) positioniert sind, wobei die schluckbare In-vivo-Sensorkapsel ferner eine Lichtquelle (23) aufweist, die auf mindestens einem starren Abschnitt (33) der Leiterplatte angeordnet ist.
2. Kapsel nach Anspruch 1, wobei die Lichtquelle (23) ein LED-Beleuchtungssystem umfasst.
3. Kapsel nach Anspruch 1 oder 2, welche ferner mindestens eine Komponente aufweist, die aus der Gruppe ausgewählt ist, die aus einem Sensor (24), einem Prozessor, einem Sender (26) und einer Kombination davon besteht.

4. Kapsel nach Anspruch 3, wobei mindestens eine Komponente auf mindestens einem starren Abschnitt der Leiterplatte angeordnet ist.
5. Kapsel nach Anspruch 3, wobei mehrere Komponenten auf mehreren starren Abschnitten der Leiterplatte angeordnet sind.
6. Kapsel nach Anspruch 3, wobei auf einem starren Abschnitt der Leiterplatte ein Bildsensor angeordnet ist und auf einem anderen starren Abschnitt der Leiterplatte ein Sender angeordnet ist.
7. Kapsel nach einem der Ansprüche 1 bis 6, wobei mehrere flexible Abschnitte vorgesehen sind und sich die starren Abschnitte mit den flexiblen Abschnitten abwechseln.
8. Kapsel nach einem der Ansprüche 1 bis 7, wobei die Leiterplatte Flexiglas umfasst.
9. Verfahren zur Herstellung einer In-vivo-Kapsel, wobei das Verfahren die folgenden Schritte umfasst:
- Anordnen mindestens eines Sensors (24) und einer Lichtquelle (23) auf einem oder mehreren starren Abschnitten (31, 33, 35) einer Leiterplatte, welche mehrere starre Abschnitte (31, 33, 35) aufweist, die jeweils durch einen flexiblen Abschnitt (32, 32') der Leiterplatte verbunden sind, und Falten der Leiterplatte in ein Gehäuse, welches für eine In-vivo-Erfassung konfiguriert ist, umfassend Positionieren einer oder mehrerer Batterien (25) zwischen zwei der starren Abschnitte (33, 35), die durch einen flexiblen Abschnitt (32, 32') verbunden sind.
10. Verfahren nach Anspruch 9, wobei der Schritt des Faltens der Leiterplatte Falten der Leiterplatte derart umfasst, dass die starren Abschnitte der Leiterplatte vertikal gestapelt sind.

#### Revendications

1. Capsule de détection (10) in vivo ingérable comprenant :
- une carte de circuit qui comporte une pluralité de sections rigides (31, 33, 35) reliées par des sections flexibles, chacune desdites sections rigides (33, 35) étant reliée par une section flexible (32, 32') de la carte de circuit, et une ou plusieurs batteries (25) étant positionnées entre deux sections rigides reliées par une section flexible, la capsule de détection in vivo ingérable comprenant en outre une source d'illumination

(23) disposée sur au moins une section rigide (33) de la carte de circuit.

2. Capsule selon la revendication 1, où ladite source d'illumination (23) comprend un système d'éclairage LED. 5
3. Capsule selon l'une des revendications 1 ou 2, comprenant en outre au moins un composant choisi parmi le groupe constitué d'un capteur (24), d'un processeur, d'un émetteur (26) ou de leur combinaison. 10
4. Capsule selon la revendication 3, où au moins un composant est disposé sur au moins une section rigide de la carte de circuit. 15
5. Capsule selon la revendication 3 où une pluralité de composants sont disposés sur une pluralité de sections rigides de la carte de circuit. 20
6. Capsule selon la revendication 3 où un capteur d'image est disposé sur une section rigide de la carte de circuit et un émetteur est disposé sur une autre section rigide de la carte de circuit. 25
7. Capsule selon l'une des revendications 1 à 6, où on prévoit une pluralité de sections flexibles, et les sections rigides s'alternent avec les sections flexibles.
8. Capsule selon l'une des revendications 1 à 7, où la carte de circuit contient du plexiglas. 30
9. Procédé de fabrication d'une capsule in vivo, le procédé comprenant les étapes qui consistent à : 35
  - disposer d'au moins un capteur (24) et d'une source d'illumination (23) sur une ou plusieurs sections rigides (31, 33, 35) d'une carte de circuit qui comporte une pluralité de sections rigides (31, 33 35) reliées chacune par une section flexible (32, 32') de la carte de circuit, et 40
  - plier la carte de circuit dans un boîtier configuré pour une détection in vivo, comportant une ou plusieurs batteries (25) positionnées entre deux desdites sections rigides (33, 35) qui sont reliées par une section flexibles (32, 32'). 45
10. Procédé selon la revendication 9, dans lequel l'étape de pliage de la carte de circuit comprend le fait de plier la carte de circuit de sorte que les sections rigides de la carte de circuit soient empilées verticalement. 50

55

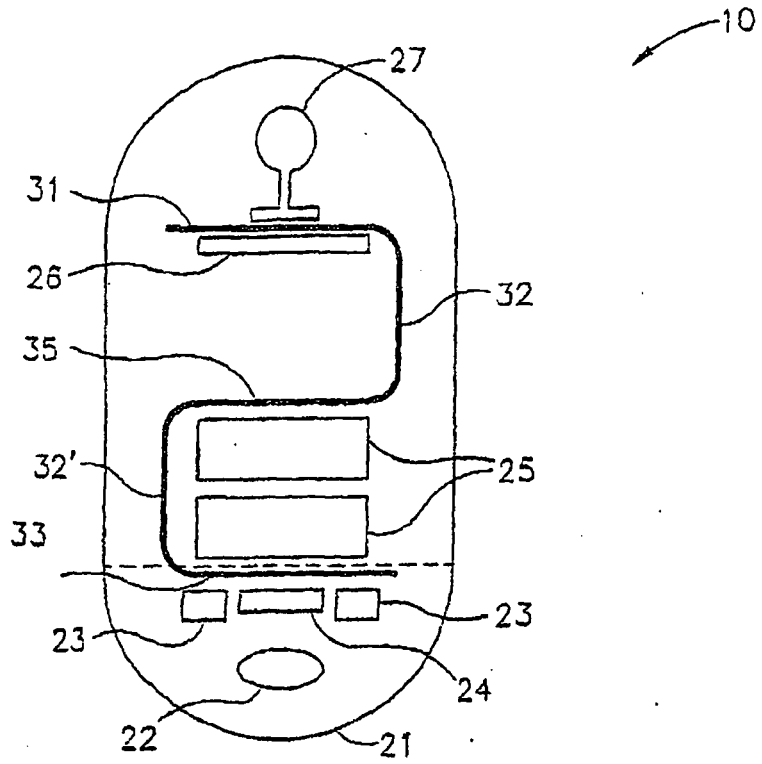

FIG. 1

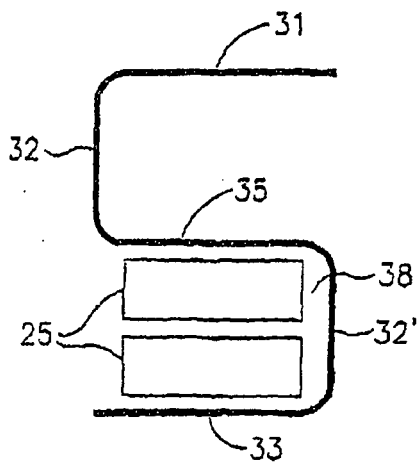

FIG. 2A

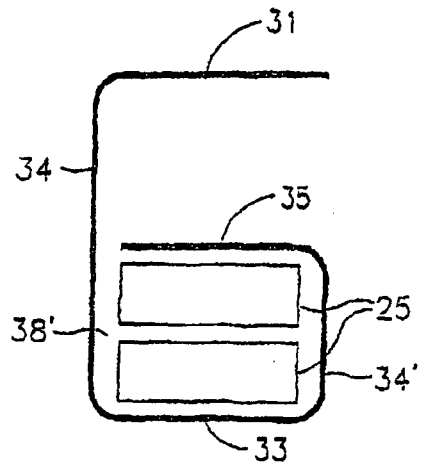

FIG. 2B

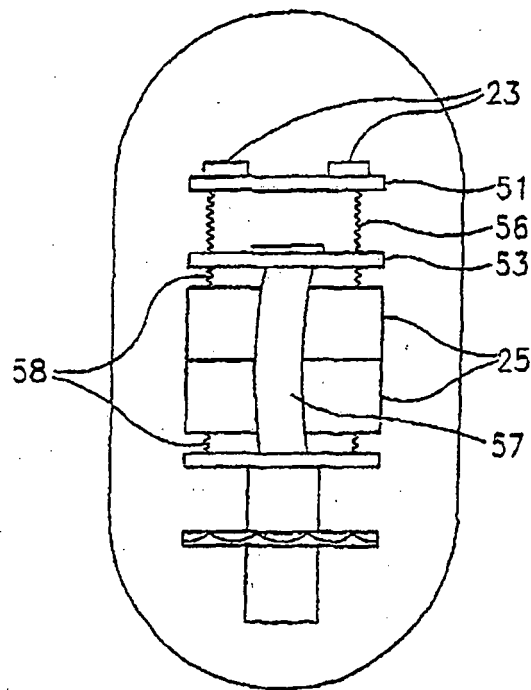

FIG. 3

**REFERENCES CITED IN THE DESCRIPTION**

*This list of references cited by the applicant is for the reader's convenience only. It does not form part of the European patent document. Even though great care has been taken in compiling the references, errors or omissions cannot be excluded and the EPO disclaims all liability in this regard.*

**Patent documents cited in the description**

- US 3791377 A [0005]
- US 4803992 A [0006]
- EP 1104182 A1 [0007]
- JP 2001091860 A [0008]
- WO 0165995 A [0013]
- US 5604531 A [0013]

**Non-patent literature cited in the description**

- **GAVRIEL D. MERON.** The development of the swallowable video capsule (M2A). *Gastrointestinal endoscopy*, 2000, vol. 52 (6), 817-819 [0003]
- **MARK APPLEYARD et al.** A randomized trial comparing wireless capsule endoscopy with push enteroscopy for the detection of small-bowel lesions. *Gastroenterology*, 2000, vol. 119, 1431-1438 [0004]

专利名称(译)	具有电路板的体内传感装置具有刚性部分和柔性部分		
公开(公告)号	<a href="#">EP1982636B2</a>	公开(公告)日	2016-09-07
申请号	EP2008161902	申请日	2002-06-18
[标]申请(专利权)人(译)	基文影像公司		
申请(专利权)人(译)	基文影像有限公司.		
当前申请(专利权)人(译)	基文影像有限公司.		
[标]发明人	AVNI DOV		
发明人	AVNI, DOV		
IPC分类号	A61B1/00 A61B5/00 H05K1/00 A61B5/01 A61B1/04 A61B1/05 A61B5/07 H05K1/18		
CPC分类号	A61B5/0031 A61B1/041 H05K1/189 H05K3/3436 H05K2201/10151 Y02P70/613		
优先权	60/298387 2001-06-18 US		
其他公开文献	EP1982636A1 EP1982636B1		
外部链接	<a href="#">Espacenet</a>		

#### 摘要(译)

一种可吞咽的体内传感胶囊 ( 10 ) , 包括 : 电路板 , 包括多个刚性部分 ( 31,33,35; 51,53 ) , 所述刚性部分 ( 33,35 ) 中的至少两个通过柔性连接部分 ( 32,32&#39; ) 和一个或多个电池 ( 25 ) 位于两个刚性部分之间 , 可吞咽的体内传感胶囊还包括设置在至少一个刚性部分 ( 33,51 ) 上的照明源 ( 23 ) 电路板。