

(19)



(11)

EP 1 827 210 B1

(12)

EUROPEAN PATENT SPECIFICATION

(45) Date of publication and mention of the grant of the patent:
07.11.2012 Bulletin 2012/45

(51) Int Cl.:
A61B 5/00 (2006.01)

(21) Application number: **05804135.1**

(86) International application number:
PCT/IL2005/001196

(22) Date of filing: **14.11.2005**

(87) International publication number:
WO 2006/054287 (26.05.2006 Gazette 2006/21)

(54) **BREAST MILK FLOW METER APPARATUS AND METHOD**

MUTTERMILCH-FLUSSMESSER UND VERFAHREN

APPAREIL ET PROCEDE DE MESURE DE DEBIT DE LAIT MATERNEL

(84) Designated Contracting States:
AT BE BG CH CY CZ DE DK EE ES FI FR GB GR HU IE IS IT LI LT LU LV MC NL PL PT RO SE SI SK TR

(74) Representative: **Leone, Mario et al**
Cantaluppi & Partners S.r.l.
Viale della Tecnica, 205
00144 Roma (IT)

(30) Priority: **18.11.2004 IL 16528904**

(56) References cited:
WO-A-01/54488 US-A- 5 827 191
US-A1- 2004 122 357

(43) Date of publication of application:
05.09.2007 Bulletin 2007/36

(73) Proprietor: **Mamsense Ltd.**
69547 Tel Aviv (IL)

- **WOOLRIDGE M W ET AL: "The continuous measurement of milk intake at a feed in breast-fed babies." September 1982 (1982-09), EARLY HUMAN DEVELOPMENT. SEP 1982, VOL. 6, NR. 4, PAGE(S) 365 - 373 , XP009062332 ISSN: 0378-3782 the whole document**

(72) Inventors:
 • **KOLBERG, Eliezer**
55201 Kiryat Ono (IL)
 • **EPSTEIN, Yitzak**
52299 Ramat Gan (IL)

EP 1 827 210 B1

Note: Within nine months of the publication of the mention of the grant of the European patent in the European Patent Bulletin, any person may give notice to the European Patent Office of opposition to that patent, in accordance with the Implementing Regulations. Notice of opposition shall not be deemed to have been filed until the opposition fee has been paid. (Art. 99(1) European Patent Convention).

Description**FIELD OF THE INVENTION**

[0001] The present invention relates to a method and a device for monitoring and measuring the quantity of milk an infant consumes during breast-feeding.

BACKGROUND OF THE INVENTION

[0002] Breast-feeding of infants has important medical and moral benefits including nutrition and immunity to illnesses. Furthermore, the breast-feeding processes also help bonding the mother and the child.

There is an essential need for monitoring and measuring the amount of milk an infant consumed in every meal.

[0003] The conventional, ancient and rather primitive method for measuring the amount of milk an infant has consumed is to weigh the infant before and after breast-feeding. This method is quite inaccurate and does not provide real time information.

[0004] An attempt to tackle this problem has been made in US Patent No. 5,827,191 (Rosenfeld), proposing to employ an elastic nipple with a built-in propeller-based flow meter, thus giving real time information of the consumed milk quantity.

[0005] The obstacles in reducing this method into practice seems to be technically insurmountable; besides, an obvious disadvantage resides in that the nipple partitions the baby from the natural contact with the flesh of his mother.

[0006] The same seems to apply to International Publication No. WO 01/54488 (Vaslov Traders (Pty) Ltd.).

[0007] Woolridge M.W. et al., "The continuous measurement of milk intake at a feed in breast-fed babies", Early Human Development, Vol. 6, No. 4, Sep. 1982, pp. 365-373, suggest a method for measuring the milk flow during breast feeding using an ultra sonic Dopple flow meter. The flow meter is placed in a latex nipple shield positioned onto the nipple. As suction is applied to the nipple shield, milk is drawn out of the breast and passes through the flow meter. The flow meter indicates the amount of milk passing through and taken in by the feeding baby.

[0008] It is therefore the prime object of the invention to provide real time measurement information about milk quantity consumed by an infant during breast-feeding.

[0009] It is a further object of the invention to provide a method and a device for accurate measuring of the quantity of milk an infant consumes during breast-feeding without creating any partition between the infant and his mother's breast.

[0010] It is a still further object of the invention to utilize an ultrasonic flow meter of the Doppler Effect type for measuring the milk quantity consumed by an infant.

SUMMARY OF THE INVENTION

[0011] Thus provided according to one aspect of the invention is a method for measuring the quantity of milk consumed by an infant during a breast-feeding session, comprising the steps of: providing a brassier of the breast-feeding type; annexing to the brassiere at each one of the two respective breast holding portions thereof ultra-sonic Doppler-Effect transmitter and receiver probes in a position directed to a location proximate to the nipple of the nursing person wearing the brassiere; activating the probes during the breast-feeding sessions whereby the amount of flow through the respective nipple is measured; and translating and accumulating the flow measurements into volume units of the consumed quantity.

[0012] According to another aspect of the invention there is provided an apparatus for measuring the quantity of milk consumed by an infant during a breast-feeding session, comprising: a brassiere-like garment with openings allowing the breasts to be exposed for nursing an infant; an ultra-sonic Doppler-Effect transmitter probe annexed to the brassiere aiming in the direction of the nipple of the nursing person; an ultra-sonic Doppler-Effect receiver probe annexed to the brassiere aiming in the direction proximate to the nipple of the nursing person.

[0013] The apparatus further comprises means for activating the probes to function as flow measuring means; means for translating and accumulating the flow measurements into volume units; and a reader unit for displaying the total of the consumed quantity.

BRIEF DESCRIPTION OF THE DRAWINGS

[0014] These and additional features of the invention will become more clearly understood in the light of the ensuing description of a preferred embodiment thereof given by way of example only, with reference to the accompanying drawings, wherein-

Fig. 1 is a schematic cross-sectional view of a human breast;

Fig. 2 is a schematic three-dimensional view of a breast-feeding subject using a brassiere designed according to the principles of the present invention;

Fig. 3 is a top-view schematically showing the location of the ultra-sonic Doppler transmitter and receiver probes relative to the breast;

Fig. 4 is a side-view of Fig. 3;

Fig. 5 shows a brassiere lining used as probes and related wiring carrier;

Fig. 6 shows the brassiere with the lining attached thereunder; and

Fig. 7 shows the breast-feeding brassiere with the front cover caps.

DETAILED DESCRIPTION OF THE PREFERRED EMBODIMENT

[0015] Before referring to the specifics of the present invention a certain introductory explanation is required with regard to the Doppler measurement technique, as well as of the physiology relevant to breast feeding.

[0016] The use of ultrasonic flow meter of the Doppler type for measuring the flow of liquids is known for industrial as well as for scientific and medical applications. For example, in US. Pat. No. 5,682,896 there is described a method and apparatus for generating volume flow measurement through blood vessels. Once the cross-section (usually the diameter) of the vessel is known the volume of flow can be reckoned by simply multiplying the cross-section by the average velocity and by the lapse of time.

[0017] A vast number of other patents relate to the same subject-matter.

[0018] As shown in Fig. 1, the breast is a gland, which consists of connective and fatty tissues 10 that support and protect the milk producing areas. The milk is produced in small clusters of cells 12 called alveoli and travels down through thin tubes 14 called ducts to milk sinuses 16, functioning as collecting reservoirs. The milk sinuses 16 drain to the outside of the breast through openings in nipple 18. The nipple is located at the center of the areola 20 having many small openings.

[0019] There are 15-20 milk ducts 14 in each breast, and the milk flows from these through the openings 18 in the nipple.

[0020] In view of the foregoing, it will be readily understood that in order to apply the Doppler-based measurement method to breast-feeding, there must be first ascertained the sum of the cross-section areas of the nipple outlet openings 18 (or of one of the milk ducts 14, which can then be multiplied by their number).

[0021] Alternatively, an initial calibration procedure can be applied before routine use of the system, e.g. by actually measuring the supply of milk per time unit.

[0022] Still another possibility is to empirically prove that there exists an average cross-sectional area which can be taken as applicable to most cases.

[0023] Reference shall now be made to Figs. 2-7 illustrating a preferred embodiment of a brassiere tailored to serve the purposes of the present invention.

[0024] The brassiere garment generally denoted 30 is multi-layered, namely consisting of a basic structure 32, having shoulder straps 34, but with large openings around the nipples area to allow exposure of the breasts for feeding the baby as known with regard to conventional breast-feeding brassieres.

[0025] The second component of the brassiere garment 30 consists of a lining member generally denoted 36 in Fig. 5. It is adapted to be attached to the basic structure 32 from inside by press-buttons 38. The lining

36 carries wiring 40 preferably sewn to the fabric as shown. The wiring 40 connects control and data processing unit 42 to two pairs of spaced ultra-sonic Doppler Effect transmitter probes 44 and receiver probes 46 (or transceivers) in such a manner that they are oriented towards a point X proximate to the nipples of the user (Figs. 3 and 4).

[0026] The angles α and β between the probes of each pair (in different planes) are relevant parameters in Doppler measurements processing as known in the art, and may be considered constant in spite of small changes that may occur during use due to the somewhat non-stable support thereof.

[0027] Caps 50 are provided for each breast, connectable to the brassiere by the press-buttons 38 seen in Figs. 5 and 7.

One or the other of these covers 50 are removed during the breast-feeding sessions.

[0028] Reader unit 52 is connected by wire 54 to the processing unit 42, conveniently worn over the neck of the user (Fig. 2).

[0029] It will be readily appreciated that the measurements produced by the unit 52 are also indicative of the presence, as well as density (i.e. quality) of the monitored milk flow at any given time.

Claims

1. A method for measuring the quantity of milk consumed by an infant during a breast-feeding session, by measuring the amount of flow through the respective nipple, using ultra-sonic Doppler-Effect probes, and translating and accumulating the flow measurements into volume units of the consumed quantity, **characterized in that** said method comprises the steps of:

- providing a brassiere (30) of the breast-feeding type having two respective breast holding portions, each with a large opening around the nipple area allowing direct exposure of the breasts to said infant during said breast-feeding session;
- annexing to brassiere, at each one of two respective breast holding portions thereof, ultra-sonic Doppler-Effect transmitter and receiver probes (44; 46) in a position directed to a location proximate to the nipple of the nursing person wearing said brassiere;
- activating probes during the breast-feeding sessions for measuring the amount of flow through the respective nipple; and
- translating and accumulating the flow measurements into volume units of the consumed quantity.

2. The method of claim 1 further comprising the step of initially calibrating the measurement of flow into

volume units as a function of time.

3. An apparatus for measuring the quantity of milk consumed by an infant during breast-feeding session, by measuring the amount of flow through the respective nipple, using ultra-sonic Doppler-Effect probes, said apparatus comprising:
- an ultra-sonic Doppler-Effect transmitter probe (44);
 an ultra-sonic Doppler-Effect receiver probe (46);
 means (42) for activating said ultra-sonic Doppler-Effect transmitter probe and said ultra-sonic Doppler-Effect receiver probe to function as flow measuring means;
 means for translating and accumulating the flow measurements into volume units; and
 a reader unit (52) for displaying the total of the consumed quantity;
characterized in that said apparatus further comprises a brassiere (30) of the breast-feeding type having openings around the nipple area for allowing the breasts to be directly exposed for nursing an infant, wherein said ultra-sonic Doppler-Effect transmitter probe and said ultra-sonic Doppler-Effect receiver probe are annexed to said brassiere at each one of the two breast holding portions of said brassiere, and are aiming in a direction proximate to the respective nipple of the nursing person.
4. The apparatus of claim 3 wherein said ultra-sonic Doppler-Effect transmitter probe and said ultra-sonic Doppler-Effect receiver probe are mounted to an inner lining member (36) attachable to said brassiere from inside.
5. The apparatus of claim 3 wherein said brassiere further includes caps (50) for covering said openings and said ultra-sonic Doppler-Effect transmitter probe and said ultra-sonic Doppler-Effect receiver probe.
6. The apparatus of claim 3 further comprising a control and data processing unit (42) mounted at the center of said brassiere, and a reading unit (52), coupled with said control and data processing unit.
7. The apparatus of claim 6 wherein said reading unit (52) is worn around the neck of said nursing person.
8. Use of the apparatus of any of claims 3-7 for indicating a presence of milk flow through a nipple.
9. Use of the apparatus of any of claims 3-7 for measuring the density of milk flowing through a nipple.

Patentansprüche

1. Verfahren zum Messen der Menge an Milch, die durch einen Säugling während einer Stillsitzung konsumiert wird, durch Messen der Menge an Fluss durch die jeweilige Brustwarze unter Verwendung von Ultraschall-Doppler-Effekt-Sonden und Umwandeln und Akkumulieren der Flussmessungen in Volumeneinheiten der konsumierten Menge, **dadurch gekennzeichnet, dass** das Verfahren die Schritte umfasst:
- Bereitstellen eines Büstenhalters (3) der Still-Art, der zwei jeweilige Brusthaltebereiche aufweist, wobei jeder eine große Öffnung um den Brustwarzenbereich besitzt, der ein direktes Freilegen der Brüste für den Säugling während der Stillsitzung erlaubt;
 - Anbringen von Ultraschall-Doppler-Effekt-Übertragungssonden und - Empfänger-sonden (44, 46) an dem Büstenhalter an jeder der zwei jeweiligen Brusthaltebereichen, in einer Position, die zu einem Ort in der Nähe der Brustwarze der stillenden Person, die den Büstenhalter trägt, gerichtet ist;
 - Aktivieren der Sonden während der Stillsitzungen zur Messung der Menge an Fluss durch die jeweilige Brustwarze; und
 - Umwandeln und Akkumulieren der Flussmessungen in Volumeneinheiten der konsumierten Menge.
2. Verfahren nach Anspruch 1, das weiterhin den Schritt des anfänglichen Kalibrierens der Messung des Flusses in Volumeneinheiten als eine Funktion der Zeit umfasst.
3. Vorrichtung zum Messen der Menge an Milch, die durch einen Säugling während einer Stillsitzung konsumiert wird, durch Messen der Menge an Fluss durch die jeweilige Brustwarze unter Verwendung von Ultraschall-Doppler-Effekt-Sonden, wobei die Vorrichtung umfasst:
- eine Ultraschall-Doppler-Effekt-Übertragungssonde (44),
 - eine Ultraschall-Doppler-Effekt-Empfänger-sonde (46);
 - Mittel (42) zum Aktivieren der Ultraschall-Doppler-Effekt-Übertragungssonde und der Ultraschall-Doppler-Effekt-Empfänger-sonde, damit diese als Fluss-Messmittel funktionieren;
 - Mittel zum Umwandeln und Akkumulieren der Fluss-Messungen in Volumeneinheiten; und
 - eine Lesereinheit (52) zur Anzeige der Gesamtheit der konsumierten Menge; **dadurch gekennzeichnet, dass** die Vorrichtung weiterhin umfasst einen Büstenhalter (30) der Still-Art,

- der Öffnungen um den Brustwarzenbereich besitzt, um es zu ermöglichen, dass die Brüste direkt freigelegt werden können, um einen Säugling zu stillen, wobei die Ultraschall-Doppler-Effekt-Übertragungssonde und die Ultraschall-Doppler-Effekt-Empfängersonde an dem Büstenhalter befestigt sind an jedem der beiden Brusthaltebereiche des Büstenhalters, und in eine Richtung in der Nähe der jeweiligen Brustwarzen der stillenden Person gerichtet sind.
4. Vorrichtung nach Anspruch 3, wobei die Ultraschall-Doppler-Effekt-Übertragungssonde und die Ultraschall-Doppler-Effekt-Empfängersonde an einem inneren Futterteil (36) befestigt sind, das von innen an dem Büstenhalter befestigbar ist.
5. Vorrichtung nach Anspruch 3, wobei der Büstenhalter weiterhin Kappen (50) umfasst, um die Öffnungen und die Ultraschall-Doppler-Effekt-Übertragungssonde und die Ultraschall-Doppler-Effekt-Empfängersonde abzudecken.
6. Vorrichtung nach Anspruch 3, weiterhin umfassend eine Steuer- und Datenverarbeitungseinheit (42), die in der Mitte des Büstenhalters befestigt ist und eine Lesereinheit (52), die mit der Steuer- und Datenverarbeitungseinheit verbunden ist.
7. Vorrichtung nach Anspruch 6, wobei die Lesereinheit (52) um den Hals der stillenden Person getragen wird.
8. Verwendung einer Vorrichtung nach einem der Ansprüche 3 bis 7 zur Anzeige des Vorliegens eines Milchflusses durch eine Brustwarze.
9. Verwendung einer Vorrichtung nach einem der Ansprüche 3 bis 7 zur Messung der Dichte der Milch, die durch eine Brustwarze fließt.
- Revendications**
1. Procédé pour mesurer la quantité de lait consommée par un bébé pendant une séance d'allaitement, en mesurant le débit à travers le mamelon respectif, en utilisant des sondes à ultrasons à effet Doppler, et en traduisant et accumulant les mesures de débit en unités de volume de la quantité consommée, **caractérisé en ce que** ledit procédé comprend les étapes suivantes .
- la fourniture d'un soutien-gorge (30) du type pour allaitement ayant deux parties de maintien de sein respectives, chacune ayant une large ouverture autour de la zone de mamelon permettant une exposition directe des seins audit bébé pendant ladite séance d'allaitement ;
 - l'annexion audit soutien-gorge, au niveau de chacune desdites deux parties de maintien de sein respectives de celui-ci, de sondes émettrice et réceptrice à ultrasons à effet Doppler (44 ; 45) dans une position orientée vers un emplacement proche du mamelon de la personne allaitante portant ledit soutien-gorge ;
 - l'activation desdites sondes pendant les séances d'allaitement pour mesurer le débit traversant le mamelon respectif ; et
 - la traduction et l'accumulation des mesures de débit en unités de volume de la quantité consommée.
2. Procédé selon la revendication 1, comprenant en outre l'étape complémentaire d'étalonnage initial de la mesure de débit en unités de volume en fonction du temps.
3. Dispositif pour mesurer la quantité de lait consommée par un bébé pendant une séance d'allaitement, en mesurant le débit à travers le mamelon respectif, en utilisant des sondes à ultrasons à effet Doppler, ledit appareil comprenant :
- une sonde émettrice à ultrasons à effet Doppler (44)
 - une sonde réceptrice à ultrasons à effet Doppler (46);
 - des moyens (42) pour activer ladite sonde émettrice à ultrasons à effet Doppler et ladite sonde réceptrice à ultrasons à effet Doppler pour qu'elles fonctionnent comme moyens de mesure de débit ;
 - des moyens pour traduire et accumuler les mesures de débit en unités de volume ; et
 - une unité de lecture (52) pour afficher le total de la quantité consommée ;
- caractérisé en ce que** ledit dispositif comprend en outre un soutien-gorge (30) du type pour allaitement ayant des ouvertures autour de la zone de mamelon pour permettre l'exposition directe des seins pour allaiter un bébé, dans lequel ladite sonde émettrice à ultrasons à effet Doppler et ladite sonde réceptrice à ultrasons à effet Doppler sont annexées audit soutien-gorge au niveau de chacune des deux parties de maintien de sein dudit soutien-gorge, et sont orientées dans une direction proche du mamelon respectif de la personne allaitante.
4. Dispositif selon la revendication 3, dans lequel ladite sonde émettrice à ultrasons à effet Doppler et ladite sonde réceptrice à ultrasons à effet Doppler sont montées sur un élément de doublure interne (36) attachable audit soutien-gorge depuis l'intérieur.

5. Dispositif selon la revendication 3, dans lequel ledit soutien-gorge est en outre doté de caches (50) pour couvrir lesdites ouvertures et ladite sonde émettrice à ultrasons à effet Doppler et ladite sonde réceptrice à ultrasons à effet Doppler. 5
6. Dispositif selon la revendication 3, comprenant en outre une unité de commande et de traitement de données (42) montée au centre dudit soutien-gorge, et une unité de lecture (52) couplée à ladite unité de commande et de traitement de données. 10
7. Dispositif selon la revendication 6, dans lequel ladite unité de lecture (52) est portée autour du cou de ladite personne allaitante. 15
8. Utilisation du dispositif selon l'une quelconque des revendications 3 à 7 pour indiquer une pression de débit de lait à travers un mamelon. 20
9. Utilisation du dispositif selon l'une quelconque des revendications 3 à 7 pour mesurer la densité de lait s'écoulant à travers un mamelon. 25

25

30

35

40

45

50

55

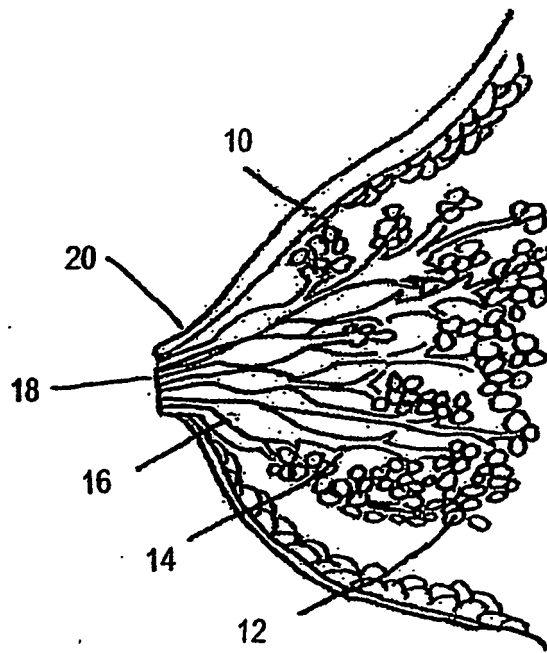

FIG. 1

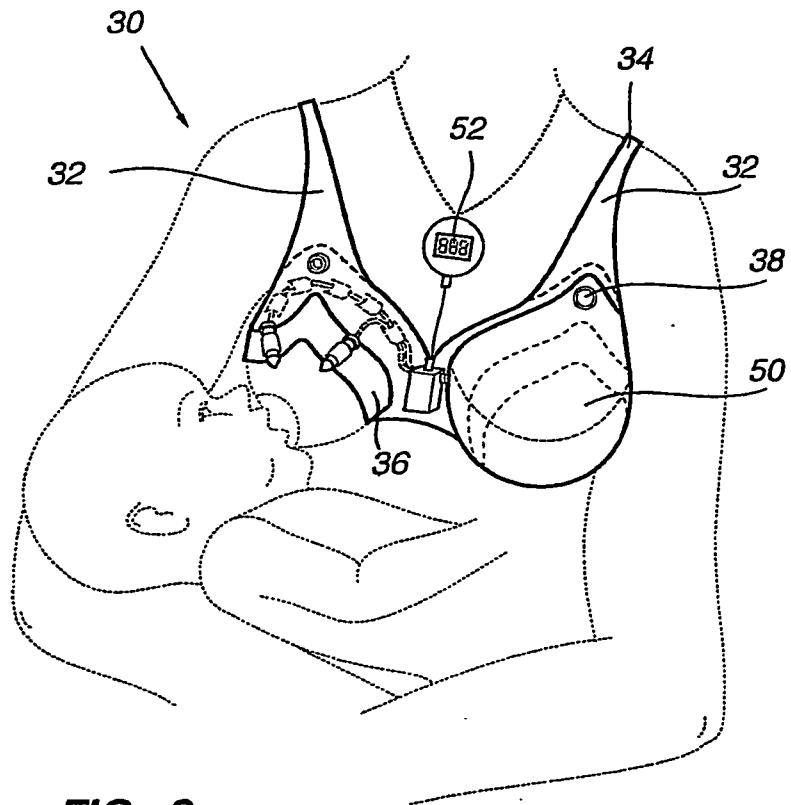

FIG. 2

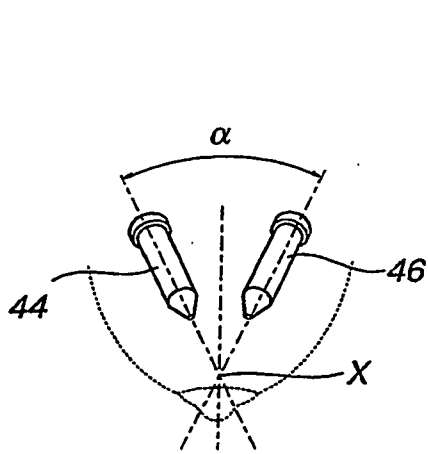

FIG. 3

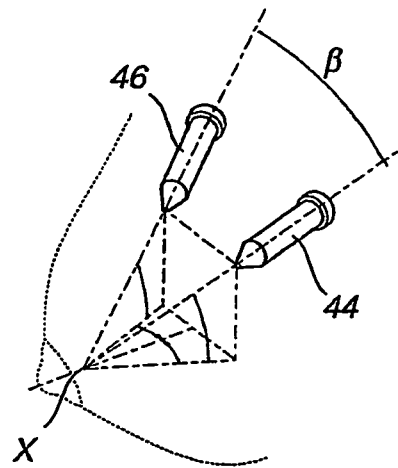

FIG. 4

FIG. 5

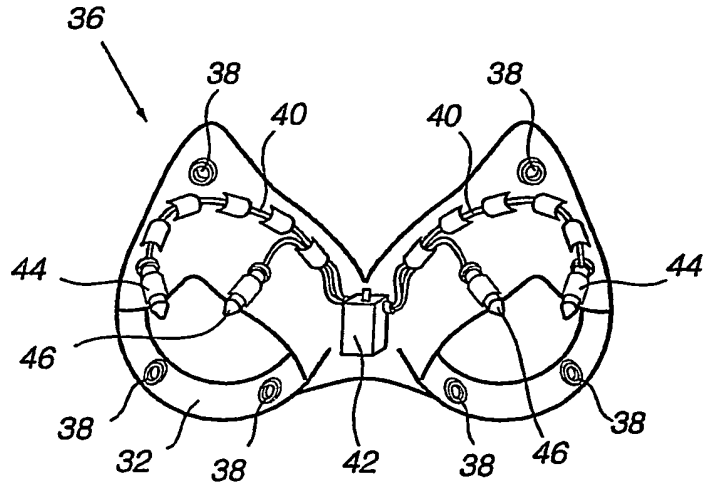

FIG. 6

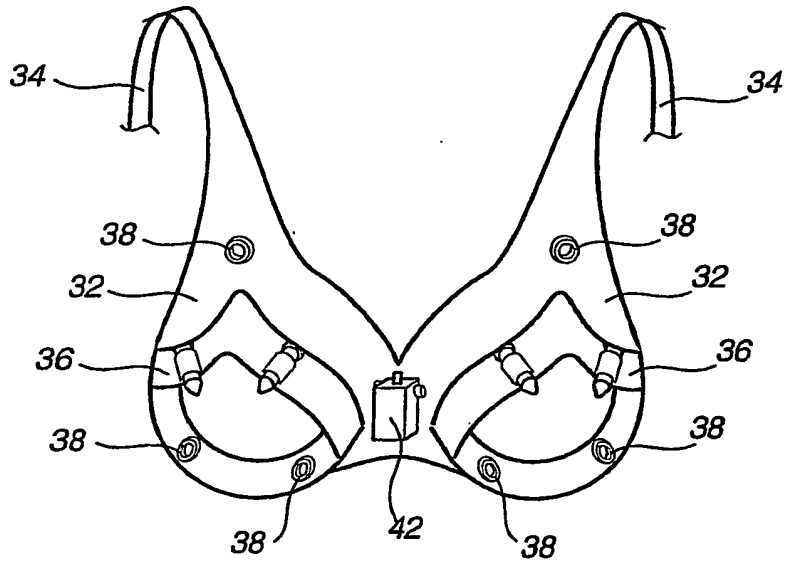
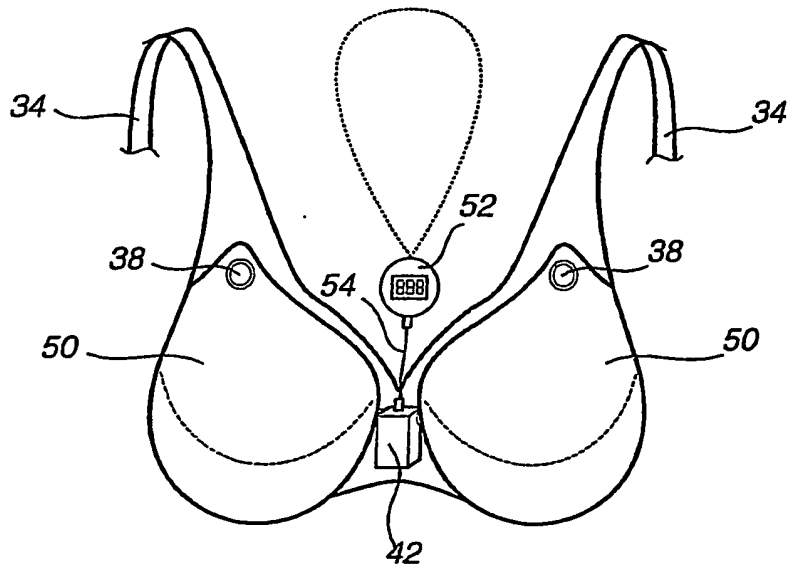

FIG. 7



REFERENCES CITED IN THE DESCRIPTION

This list of references cited by the applicant is for the reader's convenience only. It does not form part of the European patent document. Even though great care has been taken in compiling the references, errors or omissions cannot be excluded and the EPO disclaims all liability in this regard.

Patent documents cited in the description

- US 5827191 A, Rosenfeld [0004]
- WO 0154488 A [0006]
- US 5682896 A [0016]

Non-patent literature cited in the description

- **WOOLRIDGE M.W. et al.** The continuous measurement of milk intake at a feed in breast-fed babies. *Early Human Development*, September 1982, vol. 6 (4), 365-373 [0007]

专利名称(译)	母乳流量计装置和方法		
公开(公告)号	EP1827210B1	公开(公告)日	2012-11-07
申请号	EP2005804135	申请日	2005-11-14
[标]申请(专利权)人(译)	MAMSENSE		
申请(专利权)人(译)	MAMSENSE LTD.		
当前申请(专利权)人(译)	MAMSENSE LTD.		
[标]发明人	KOLBERG ELIEZER EPSTEIN YITZAK		
发明人	KOLBERG, ELIEZER EPSTEIN, YITZAK		
IPC分类号	A61B5/00 A61B8/08 G01F1/66 G01N		
CPC分类号	A61B5/4312 A61B5/4288 A61B5/6804 A61B8/488 G01F1/663		
代理机构(译)	LEONE , MARIO		
优先权	165289 2004-11-18 IL		
其他公开文献	EP1827210A1		
外部链接	Espacenet		

摘要(译)

根据本发明提供了一种用于测量婴儿在母乳喂养期间消耗的乳量的装置。该装置包括类似胸罩的衣服 (30)，其具有允许乳房暴露以用于哺乳婴儿的开口。衬里 (32) 连接到胸罩的内侧。超声多普勒效应发射器探头 (44) 和接收器探头 (46) 附在胸罩衬里上，指向护理人员各自乳头的方向。提供了用于将探针 (44,46) 的流量测量值转换成体积单位的装置。

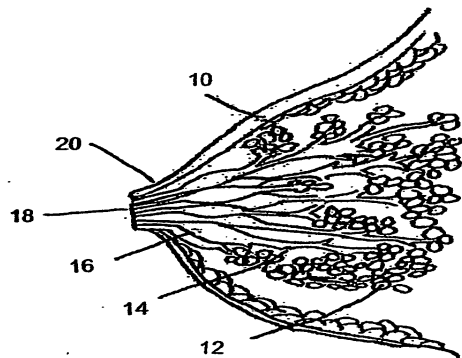

FIG. 1