



(11) **EP 1 774 908 B1**

(12) **EUROPEAN PATENT SPECIFICATION**

(45) Date of publication and mention of the grant of the patent:
06.04.2011 Bulletin 2011/14

(51) Int Cl.:
A61B 5/151 (2006.01) A61B 10/00 (2006.01)

(21) Application number: **06255275.7**

(22) Date of filing: **13.10.2006**

(54) **Integrated lance and strip for analyte measurement**

Integrierte Lanzette und Teststreifen zur analytischen Messung

Lancette et bande de test intégrés pour la mesure d'un analyte

(84) Designated Contracting States:
AT BE BG CH CY CZ DE DK EE ES FI FR GB GR HU IE IS IT LI LT LU LV MC NL PL PT RO SE SI SK TR

(30) Priority: **14.10.2005 US 251189**

(43) Date of publication of application:
18.04.2007 Bulletin 2007/16

(73) Proprietor: **LifeScan, Inc.**
Milpitas, CA 95035 (US)

(72) Inventor: **Allen, John J.**
Mendota Heights, Minnesota 55118 (US)

(74) Representative: **Tunstall, Christopher Stephen et al**
Carpmaels & Ransford
One Southampton Row
London
WC1B 5HA (GB)

(56) References cited:
EP-A- 1 462 053 WO-A-2004/041088
US-A- 4 753 641

EP 1 774 908 B1

Note: Within nine months of the publication of the mention of the grant of the European patent in the European Patent Bulletin, any person may give notice to the European Patent Office of opposition to that patent, in accordance with the Implementing Regulations. Notice of opposition shall not be deemed to have been filed until the opposition fee has been paid. (Art. 99(1) European Patent Convention).

Description**BACKGROUND OF THE INVENTION**Field of the Invention

[0001] The present invention relates, in general, to lancing elements for use in drawing bodily fluids out of a patient and, more particularly, to an improved lancing element including first and second elements positioned relative to each other such that an incision formed by the first element is held open by the second element and bodily fluids are pulled up the lancing element by surface tension on the first and second lancing elements.

Description of the Related Art

[0002] Integrated skin lancing and bodily fluid analysis samplers are known in the art. One such system is described and illustrated in WO 02/49507. The integrated system described in WO 02/49507 includes a lancing element or lance, which is attached to or integrated with a sensor strip adapted to measure the quantity of an analyte in bodily fluid or, alternatively, some characteristic of the bodily fluid. Usable bodily fluids may include, for example, blood or interstitial fluid (ISP). The lancing element is used to make an incision in the skin and the bodily fluid is drawn up the lancing element to the sensor strip by, for example, capillary action. Such integrated samplers may be combined with, for example, an electrochemical meter and referred to as monolithic or in-situ sampling devices.

[0003] Many lancing devices have been devised to form incisions and to enable bodily fluids to be withdrawn from those incisions. Solid lancets are used to open an incision in the skin to allow bodily fluids to escape to the surface of the skin where they can be sampled by the patient or the doctor. In order to ensure that enough fluid is released from the incision, such solid lancing elements are generally larger in diameter to facilitate the flow of sufficient bodily fluids from the incision for sampling purposes. However, such solid needles generally rely on the size of the incision to ensure that enough bodily fluids are expressed and are not used to facilitate the flow of fluids to the testing apparatus.

[0004] Hollow needles have also been described for use in drawing fluids out of the body for testing purposes; such needles may have a pointed or beveled end to facilitate opening the incision. In such needles, the incision is held open by the outer diameter of the needle to facilitate the flow of bodily fluids out of the incision and the bodily fluids are drawn up the needle either by a vacuum or by capillary action or by a combination of vacuum and capillary action.

[0005] Other lancing devices have been described wherein the lance is a flat or partially curved piece which includes an open channel for guiding fluid from the sharpened tip to the proximal end of the lance by means of,

for example, surface tension and/or capillary action. Such lancing elements are advantageous because of the ease of manufacture and the ease of integrating them into, for example, a sensor strip, in order to facilitate both lancing and measurement in a single element. Where the landing element is a flat or partially flat piece which includes an open channel for guiding fluid, it is possible for the edges of the incision to close on the channel, fully or partially blocking the channel and preventing bodily fluids from flowing to the proximal end of the channel or limiting the amount of fluid which can flow.

WO2004/041088 and EP 1462053 describe a lance comprising a lancing element having a sharpened tip and a separation element having a separation tip. The separation tip is positioned proximal to said sharpened tip. A connector connects a proximal portion of the lancing element to a proximal portion of the separation element and forms a fill channel comprising an upper chamber wall and a lower chamber wall.

Problem to be Solved

[0006] It would, therefore, be advantageous to design a lancing device where the lancing element is a flat or partially curved piece including an open channel and the lancing element includes a separation element for holding the incision open when the lancing element is in the wound and preventing the edges of the incision from closing on the lancing element and partially or fully blocking the open channel. It would be advantageous to design a lancing device wherein the separation element is positioned slightly proximal to the sharpened tip of the lancing element to facilitate insertion of the lance into the skin. It would further be advantageous to design a lancing device wherein the lancing element and the separation element are formed from a single metal sheet. It would further be advantageous to design a lancing device wherein the lancing element and the separation element are positioned opposite each other such that fluid is pulled up the lancing element and into the open channel by surface tension between the fluid and the lancing element and separation element, thus facilitating the filling of the channel. It would further be advantageous to design a lancing device wherein the lancing element and the separation element are formed from a single sheet of metal rolled to position the separation element opposite the lancing element such that the proximal end of the lancing element and the separation element form an open channel. It would further be advantageous to manufacture the lancing devices described herein using, for example, a metal forming or stamping process.

SUMMARY OF THE INVENTION

[0007] A lance according to the present invention includes a lancing element having a first sharpened end point, a separation element having a second sharpened end point wherein the second sharpened end point is

positioned proximal to the first sharpened end point, a connector connecting a proximal portion of the first lancing element to a proximal portion of the separation element, the connector forming a fill channel. The fill channel comprises an upper chamber wall and a lower chamber wall and the upper chamber wall is orientated with respect to said lower chamber wall to form a fold angle, wherein the fold angle ranges from about 10° to about 30°. In a further embodiment of the present invention, the separation element is positioned at an angle to the lancing element. In a further embodiment of the present invention the lancing element, the separation element and the channel are formed from a single sheet of metal. In a further embodiment of the present invention, a space between the lancing element and the separation element forms a gap, the gap increasing in size proximal to the second sharpened tip. In a further embodiment of the present invention, at least a portion of the channel is treated with a hydrophilic surface coating. In a further embodiment of the present invention, at least a portion of the lancing element and at least a portion of the separation element are coated with a hydrophilic surface coating. In a further embodiment of the present invention, a proximal end of the channel is integrated into a sensor strip. In a further embodiment of the present invention, the sensor strip is connected at a proximal end thereof to a plurality of additional sensor strips

BRIEF DESCRIPTION OF THE DRAWINGS

[0008] While the novel features of the invention are set forth with particularity in the appended claims, a better understanding of the features and advantages of the present invention will be obtained by reference to the following detailed description that sets forth illustrative embodiments, in which the principles of the invention are utilized, and the accompanying drawings of which:

[0009] Figure 1 is a perspective view of lancing element and sensor strip according to the present invention;

[0010] Figure 2 is a perspective view of the top layer of a lancing element according to the present invention;

[0011] Figure 3 is a perspective view of another embodiment of the invention in which multiple sensor strips form an array of sensors for use in a cartridge format;

[0012] Figure 4 is a bottom perspective view of a top layer having a lance according to another embodiment of this invention;

[0013] Figure 5 is a bottom plan view of the top layer and the lance in accordance with the embodiment shown in Figure 4;

[0014] Figure 6 is a bottom plan view of the top layer in which the lance was not folded in accordance with the embodiment shown in Figure 4;

[0015] Figure 7 is a bottom plan view of the top layer in which a handle portion was removed in accordance with the embodiment shown in Figure 4;

[0016] Figure 8 is a distal plan view of the top layer of Figure 7 taken along viewpoint 8-8;

[0017] Figure 9 is a proximal plan view of the top layer of Figure 7 taken along viewpoint 9-9;

[0018] Figure 10 is a bottom perspective view of the lance;

5 [0019] Figure 11 is a side plan view of the lance; and

[0020] Figure 12 is an expanded side plan view of the lance.

DETAILED DESCRIPTION OF ILLUSTRATIVE EMBODIMENTS OF THE INVENTION

10 [0021] Figure 1 is a perspective view of lance 15 and sensor strip 100 according to the present invention. In Figure 1, lance 15 is connected to sensor strip 100. Sensor strip 100 may be, for example, a glucose sensor strip which uses electrochemistry to measure the amount of glucose in a bodily fluid, such as, for example, blood or interstitial fluid. Additionally, sensor strip 100 may be, for example, a coagulation sensor which measures a physical characteristic of a bodily fluid such as viscosity, capacitance, resistance, and the like. In Figure 1, lance 15 further includes lancing element 22 and separation element 24. Sensor strip 100 further includes first electrode contact 10, adhesive layer 11, conductive substrate 12, vent hole 13, second electrode contact 17, insulating substrate 18, insulating layer 20, registration hole 23 and working electrode 36. In an embodiment of the invention, sensor strip 100 may have an approximate width of 5,59 mm (0.22 inches) and an approximate length of 14,0 mm (0.55 inches).

30 [0022] Figure 2 is a perspective view of lance 15 and the top layer of sensor strip 100 for use in the present invention. In Figure 2, the top layer of sensor strip 100 and lance 15 is formed from conductive substrate 12. In the embodiment illustrated in Figure 2, conductive substrate 12 includes vent hole 13 and registration hole 23. In Figure 2, lance 15 includes lancing element 22, separation element 24 and fill channel 21.

35 [0023] One embodiment of a lancing element and sensor strip suitable for use in the present invention may be described with reference to Figures 1 and 2. In the embodiment illustrated in Figures 1 and 2, sensor strip 100 includes first electrode contact 10, wherein first electrode contact 10 may be screen printed on an insulating substrate 18, and a second electrode contact 17, wherein second electrode contact 17 comprises a portion of conductive substrate 12 which is contiguous with reference electrode 37 and lance 15. In the embodiment of the lancing element and sensor strip illustrated in Figures 1 and 2, the orientation of first electrode contact 10 and second electrode contact 17 are arranged such that an analyte measurement meter, such as, for example, a glucose meter (not shown) can establish electrical contact with sensor strip 100. In the illustrated embodiment, first electrode contact 10 and second electrode contact 17 are arranged on the same side of insulating substrate 18 to facilitate contact of both electrodes at the distal end of sensor strip 100.

[0024] Sensor strip 100 is manufactured using adhesive layer 11 to attach insulating substrate 18 to conductive substrate 12. Adhesive layer 11 could be implemented in a number of ways, including using pressure sensitive material, heat activated material, or UV cured double sided adhesive material. Conductive substrate 12 may be, for example, a sheet of electrically conductive material such as gold or plated stainless steel. The geometry of conductive substrate 12 may be formed by, for example, stamping process or photo etching. In the embodiment illustrated in Figures 1 and 2, lance 15 may be manufactured as an integral part of conductive substrate 12. Vent hole 13, may be formed by, for example, punching through conductive substrate 12. Vent hole 13 is used to facilitate the transport of bodily fluid up lance 15 and across working electrode 36. Registration hole 23 may be formed during the stamping process of making conductive substrate 12.

[0025] In one embodiment of the invention, an analyte sensing layer may be, for example, a glucose sensing layer, including an enzyme, a buffer, and a redox mediator. An analyte sensing layer (not shown) may preferably be deposited on top of working electrode 36. Where an analyte sensing layer is used to detect the presence and concentration of glucose in a bodily fluid, at least a portion of glucose sensing layer dissolves in the bodily fluid and is used to convert the glucose concentration into an electrically measured parameter which is proportional to the glucose concentration in the sample.

[0026] In the embodiment illustrated in Figures 1 and 2, lance 15 has a distal and a proximal end and the proximal end is integrated with reference electrode 37 and the distal end includes sharpened tip 38 at the distal end of lancing element 22. Lance 15 may be formed by the process of stamping or photo-etching a conductive metal sheet. Photo-etching lance 15 is also beneficial in facilitating the manufacture of a lancing element which has a sharp lancing element 22 and separation element 24. In a subsequent process step, lance 15, lancing element 22, and separation element 24 may be bent to form a "V" or "U" shaped channel geometry as shown in Figure 2. Fill channel 21 serves as a conduit from lancing element 22 and separation element 24 to working electrode 36 and reference electrode 37. In one embodiment of the present invention, the distal end of lancing element 22 and separation tip 40 of separation element 24 are offset by about 0,127 mm (0.005 inches) to 0,508 mm (0.020 inches).

[0027] The design of lance 15 is adapted to more effectively cut skin due to a sharper leading point of lancing element 22. As illustrated in Figure 2, with separation tip 40 offset distally from sharpened tip 38 of element 22, the extreme distal end of lance 15 comprises only sharpened tip 38 which may be a very sharp point or edge to facilitate the initial incision as lancing element 22 enters the skin. In contrast, if lancing element 22 and separation element 24 were coincident, the leading point of lance 15 would include both sharpened tip 38 and separation

tip 40 making the combination less sharp than the embodiment illustrated in Figure 2 and requiring more force to create the initial incision. The offset of sharpened tip 38 and separation tip 40 make lance 15 more manufacturable because it reduces the inherent alignment difficulties in bringing the sharp point of lancing element 22 and separation element 24 into alignment or contact with each other. The embodiment of the invention illustrated in Figures 1 and 2 is further beneficial because it enhances fluid egress by helping to spread and hold open the skin wound after the initial incision is made. In the embodiment illustrated in Figures 1 and 2, the lance 15 further includes reference electrode 37 and second electrode contact 17. Alternative embodiments may include forming all of the electrodes and electrode contacts on insulating substrate 18.

[0028] In the embodiment of the invention illustrated in Figure 2, lance 15 includes fill channel 21, wherein the seamless transition between the lancing element 22 and separation element 24; and fill channel 21 facilitates the flow of bodily fluid from the wound to working electrode 36. Additionally, the seamless transition between the lancing element 22, separation element 24 and fill channel 21 prevents the introduction of stop junctions which can impede the capillary flow rate of liquid samples. The unique geometry increases the likelihood that a liquid sample will sufficiently cover working electrode 36 and reference electrode 37 regardless of the height of the lance 15 above or below the skin wound, or even if lance 15 lies horizontally offset from the wound. In certain embodiments of the invention, sample can be applied to the side of lance 15 rather than just the proximal end of lance 15 which provides a user the option of dosing sample onto sensor strip 100 after a site has been lanced separately.

[0029] In the embodiment of the invention illustrated in Figure 2, the gap 42 between lancing element 22 and separation element 24 guides bodily fluids into fill channel 21. The increasing separation between lancing element 22 and separation element 24 as fluid moves distally towards fill channel 21 facilitates the drawing of fluid into fill channel 21 and from fill channel 21 to sensor strip 100. As gap 42 narrows towards a distal end of separation tip 40 of separation element 24, the surface tension between the bodily fluid in gap 42 and the walls of gap 42 increases, thus bodily fluid is drawn more readily into gap 42, and up into sensor strip 100. Gap 42 is also advantageous in that it facilitates the introduction of bodily fluids into fill channel 21 by facilitating the flow of bodily fluids positioned to the side of gap 42, thus enhancing the ways in which sensor strip 100 may be used to gather bodily fluids.

[0030] Fill channel 21 may facilitate the flow of bodily fluids by, for example, wicking or capillary action. In the embodiment illustrated in Figures 1 and 2, fill channel 21 has an open geometry which facilitates the wicking of viscous samples and provides for simpler manufacturing techniques when compared with closed capillary chan-

nels. For certain embodiments of the invention, fill channel 21 may be coated with a surfactant coating or undergo a hydrophilic surface treatment to increase the capillary force within fill channel 21. For certain embodiments of the invention separation element 24 and lancing element 22 may be coated with a surfactant coating or undergo hydrophilic surface treatment to increase the capillary flow force within gap 42. Additionally, the open geometry of fill channel 21 facilitates the wicking of sample because it prevents the formation of a vacuum block. In a closed channel geometry, a capillary inlet can become plugged if it is positioned too close to the wound or inside the wound preventing air from facilitating the flow of sample to the capillary. With the open geometry of fill channel 21, the proximal end of lance 15 can be positioned arbitrarily close to the source of the blood and allow for sufficient fill of sample. In this embodiment of the invention, the open geometry of fill channel 21 has the capacity to hold a larger sample volume than the minimum sample volume to cover reference electrode 37 and working electrode 36. The open geometry of fill channel 21 thus allows excess sample to accumulate along fill channel 21 which helps leave a cleaner wound site.

[0031] In the illustrated embodiment as shown in Figure 2, the geometry of reference electrode 37 may be formed during the stamping process which effectively embosses the surface of conductive substrate 12. The stamping process may provide the pressure needed to create a recess in conductive substrate 12 which can help define the distance between reference electrode 37 and working electrode 36. For certain applications of the described invention, it may be advantageous to control the distance between reference electrode 37 and working electrode 36 by embossing conductive substrate 12 instead of controlling the thickness of adhesive layer 11. For other applications of the described invention, it may also be advantageous to not emboss the conductive substrate 12 and use adhesive layer 11 to help define the geometry of reference electrode 37.

[0032] In the embodiment of sensor strip 100 illustrated in Figure 1, insulating substrate 18 consists of material such as polyester or ceramic on which a conductive material can be printed onto insulating substrate 18 through silkscreening, sputtering, or electro-less deposition. Conductive material deposited on insulating substrate 18 forms first electrode contact 10 and working electrode 36. Insulating layer 20 may be, for example, screen printed to form a boundary for first electrode contact 10 and working electrode 36.

[0033] Figure 3 is a perspective view of another embodiment of the invention in which multiple sensor strips form an array of sensors for use in a cartridge format. Such an array may be inserted into a meter (not shown) having sensor strips dispensed in a serial manner, one by one. The format of this embodiment allows a row of sensor strips to be folded in a manner similar to an accordion wherein several sensor strips similar to sensor strip 100 in Figure 1 are attached together on an arrange-

ment which facilitates their use in a cartridge. In Figure 3, conductive substrate 12 is stamped in a progressive manner to form lance 15 such that several of them are chained together in series. The stamping process of conductive substrate 12 forms index hole 31, neck 32, and contact hole 33.

[0034] In a further embodiment of the invention, a second electrode layer (not shown) comprising an adhesive layer and glucose sensing layer would be attached to conductive substrate 12 as illustrated in Figure 3. A contact area for a reference electrode for all of the sensor strips within the array may be formed using a single area within conductive substrate 12. However, individual contacts must be made for working electrode 36 for all of the sensor strips within the array. In the embodiment of this invention, index hole 31 is used to index the sensor strip cartridge so that it can move a fresh sensor strip to a test position. Neck 32 is punched in between two adjacent sensor strips. The purpose of neck 32 is to facilitate the sensor strip bending at the location of neck 32. In order for the sensor strip to be expressed such that a user can apply blood, the sensor strip is bent downward and neck 32 facilitates bending at a defined location. Contact hole 33 on conductive substrate 12 allows electrical contact to be made with a working electrode on an insulating substrate.

[0035] A lance 15 constructed in accordance with the present invention is beneficial due to the seamless transition between the tip section and the capillary section, and because the tip itself is a type of capillary. The unique construction of this design better insures that bodily fluids enter the fill channel 21 regardless of the height of the tip above or below the skin wound, or even if the tip lies horizontally offset from the wound, where the lance acts as a conduit for the bodily fluids.

[0036] A sensor strip 100 constructed according to the present invention is more easily by manufactured than a closed channel sensor strip. Such a sensor strip may be manufactured by, for example, injection molding, embossing, or chemical etching, or even simple machining. While the capillary force of an open channel may be weaker than a comparable closed channel, the weakness can be overcome with the use of, for example, hydrophilic surface treatments or surfactant coatings including: Tween-80, a product of Sigma Chemical Co., St. Louis, Mo.; Aerosol OT a product of Cytec Industries, West Paterson, New Jersey; JBR-515, a product of Jeneil Biosurfactant Company of Saukville, Wisconsin; and Nipaproof a product of Sigma Chemical Co., St. Louis, Mo.

[0037] A sensor strip 100 constructed according to the present invention may have improved transfer properties because the invention described herein prevents the creation of a vacuum block in fill channel 21 that would prevent fluid from moving through the fill channel 21 and onto the measurement pad. With a closed channel capillary, the inlet must be positioned or designed to ensure that air is not prevented from freely entering the capillary during transfer into the measurement area. Thus, in a

closed channel system, if the inlet is positioned too close to the wound or even inside it, flow may be disrupted or stopped. With the open channel of a sensor strip designed in accordance with the present invention, however, the inlet to the channel can be positioned arbitrarily close to the source of the blood.

[0038] Another advantage of a sensor strip in accordance with the present invention including an open channel is that such a sensor strip has the capacity to hold a larger volume of fluid than the minimum required to fill and initiate transfer into the measurement pad. One embodiment of the present invention the minimum volume required to fill the lance such that the column of fluid reaches the measurement pad is approximately 230 nL. However, lancing may produce quantities which are greater than 230nL. Because of the open channel form in the present invention, the excess blood that is presented to the lance will continue to accumulate along the lance channel, forming a bulging drop of blood. This property is useful in that it clears away excess blood from the skin, leaving a cleaner lance wound.

[0039] Another advantage of the open channel design in accordance with the present invention is that a drop of fluid can be applied to the side of the lance rather than just at the tip of the lance (i.e. in a closed channel there is a distinct area where fluid must be presented to be drawn into the capillary. Manual application of blood might be required if the blood comes from a site that has been lanced separately. Thus, using a sensor strip designed in accordance with the present invention, provides the option of 'side' tilling increases the user's options.

[0040] In one embodiment of the present invention, the stamped metal of conductive substrate 12 could also serve as a working or counter electrode. A unique aspect of the sheet metal design used in the present invention is the fact that it also allows the assembly to be constructed with first electrical contact 10 and second electrode contact 17 on the same side of the sensor strip. This greatly simplifies the requirements for mating contacts on a meter because conductive substrate 12 comprises a solid conductor allowing electrical contact to be established from both the top and bottom side of conductive substrate 12, wherein the top side of conductive substrate 12 is on the same side as second electrical contact 17 and the bottom side of conductive substrate is on the same side as reference electrode 37.

[0041] On a conventionally constructed electrochemical sensor strips using a facing electrode arrangement where both working and reference electrodes are printed or applied onto an insulating substrate, the electrical contacts must be positioned on opposites sides of the sensor strip making the meter contacts more complex. If reference electrode 37 was printed or applied onto an insulating substrate, conductive substrate 12 would be insulated on the top side preventing electrical connection to be established from the top side. It could be possible to establish electrical connection from the top side if there was a partial removal of insulation from conductive sub-

strate 12. however, this would add additional complexity to the manufacturing of the sensor strip.

[0042] Finally, because sheet metal forming can be done as a progressive die stamping, in a sensor strip designed in accordance with the present invention with individual lances chained together in series, it could be possible to construct an array of test sensors with a single, common reference thus requiring just one contact.

[0043] Figure 4 is a bottom perspective view of a top layer 200 according to another embodiment of this invention. In Figure 4, top layer 200 includes a conductive substrate 201, a handle portion 203, a main body 224, a hole 202, a vent hole 226, and a lance 204. Conductive substrate 201 may be a material called "stainless steel 301" in the form of a sheet having about a 0.003 inch thickness. Handle portion 203 and hole 202 may be used to immobilize and register top layer 200 when it undergoes a stamping process. Handle portion 203 may then subsequently be removed by a cutting process at two portions denoted at lines X-X' as shown in Figure 5. Figure 7 shows a bottom view of top layer 200 after handle portion 203 was removed.

[0044] Figure 10 and 11 show a bottom perspective view and side plan view, respectively, of lance 204 illustrating a fill channel 222. Fill channel 222 may be an open faced capillary which can be formed by an upper chamber wall 218 and lower chamber wall 220. Fill channel 222 facilitates the flow of bodily fluid from lancing element 212 to the working and the reference electrodes used for measuring an analyte. Note that, fill channel 222 may also be a connector connecting a proximal portion of lancing element 212 to a proximal portion of separation element 208. In Figure 10, upper chamber wall 218 is connected to a proximal portion of lancing element 212 and lower chamber wall 220 is connected to a proximal portion of separation element 208.

[0045] In the present embodiment, top layer 200 may be disposed onto a base substrate 18 to form a sensor strip in a manner similar to that shown in Figure 1. In another embodiment of this invention, a commercially available OneTouch Ultra sensor strip from LifeScan Inc. (Milpitas, California, U.S.A.) may be modified to adapt to top layer 200 allowing the lancing process, blood dosing process, and glucose measurement process to be integrated together.

[0046] Figures 5 and 6 show a bottom plan view of top layer 200 with lance 204 in its folded and unfolded orientation, respectively. Note that the unfolded orientation may also be referred to as a flat pattern. When top layer 200 is stamped, lance 204 is in an unfolded orientation as shown in Figure 6. In a subsequent processing step, separation element 208 and lower chamber wall 220 are folded along an axis Z1 such that they are deposited over lancing element 212 and upper chamber wall 218, respectively, as shown in Figures 5 and 10. In an embodiment of the present invention, lance 204 may include a separation element 208 having a separation tip 206, and a lancing element 212 having a sharpened tip 214. Note

that sharpened tip 214 may also be referred to as a first sharpened end point and that separation tip 206 may be referred to as a second end point.

[0047] During the stamping process, top layer 200 can be embossed to form a stiffening rib 210. This embossing process increases the bending rigidity of conductive substrate 201 to reduce the likelihood of deforming lance 204 during the sensor strip manufacturing and handling process as well as the lancing process. In an embodiment of this invention, stiffening rib 210 may be positioned such that a portion of stiffening rib 210 is deposited on both lance 204 and main body 224. Stiffening rib 210 forms a bridge across lance 204 and main body 224 which strengthens the bending rigidity of lance 204 with respect to main body 224.

[0048] Separation tip 206 may be positioned a distance D1 from sharpened tip 214 as shown in Figures 5 and 6. Distance D1 may range from about 0,127 mm (0.005 inches) to about 0,508 mm (0.020 inches). Lancing element 212 may have a length L1 which may range from about 1,52 mm (0.06 inches) to about 1,78 mm (0.07 inches). Length L1 may be selected to be a distance which represents the approximate maximum depth in which lance 204 will penetrate the user's skin. Lance 204 may have a length L2 which represent the length L1 plus the length of fill channel 222 which transfers the bodily fluid to the working and reference electrodes. Length L2 may range from about 3,56 mm (0.14 inches) to about 4,06 mm (0.16 inches).

[0049] Lancing element 212 and separation element 208 may respectively have a sharpness angle A and A2 as shown in Figure 6. Lancing element 212 and separation element 208 may both form a triangular shape. Sharpness angle A1 may be formed by a vertex which corresponds with sharpened tip 214 and two lancing element sides 213. Similarly, sharpness angle A2 may be formed by a vertex which corresponds to separation tip 206 and two separation element sides 207. In an embodiment of the present invention, sharpness angles A 1 and A2 may range from about 10° to about 25°, and preferably range from about 13° to about 14°.

[0050] In the case where sharpness angle A1 or A2 is less than about 10°, there may not be sufficient structural rigidity to prevent deformation of lancing element 212 and separation element 208 during the lancing process. For example, lance 204 may be made with a material called "stainless steel 301" which has a thickness of about 0.003 inches. In addition, when sharpness angle A1 or A2 is less than about 10°, this causes an overall width of lancing element 212 and separation element 208 to decrease and this may reduce capillarity and prevent sufficient bodily fluid from being collected. The overall width of lancing element 212 may be defined as a distance between the two lancing element sides 213 in a direction perpendicular to axis Z2. The overall width of separation element 208 may be defined as a distance between the two separation element sides 207 in a direction perpendicular to axis Z2.

[0051] Lancing element 212 may not easily puncture a user's skin when sharpness angle A 1 is greater than about 25° because sharpened tip has in a sense become blunt. In such a case, if lancing element 212 was to puncture the user's skin, then the user will most likely experience an unacceptable level of pain.

[0052] Figure 8 is a distal plan view of top layer 200 of Figure 7 taken along viewpoint 8-8. The axis Z1 runs approximately parallel to a bend axis between upper chamber wall 218 and lower chamber wall 220. The bend is formed after the process in which separation element 208 and lower chamber wall 220 are folded over lancing element 212 and upper chamber wall 218. Top layer 200 has a first substantially planar portion which includes an upper chamber wall 218 as shown in Figure 8. Top layer 200 further has a second substantially planar portion which includes a lower chamber wall 220 as shown in Figure 8. Lower chamber wall is orientated with respect to upper chamber wall at a fold angle A3. In an embodiment of the present invention, the fold angle A3 may range from about 10° to about 30°, and preferably range from about 18° to about 22°.

[0053] Figure 9 is a proximal plan view of top layer 200 of Figure 7 taken along viewpoint 9-9. Lance 204 further includes a gap 216 which provides an opening for bodily fluid to enter or pass through to lance 204. It is an advantage of this invention in that lance 204 is prepared from a relatively thin sheet of metal such as, for example, 0,0762 mm (0.003 inches) thick which can be used to create a sufficiently large hole in a user's skin to withdraw a sufficient volume of bodily fluid. For example, if lance 204 was not folded over, it would create a wound size that would be limited in one dimension to be no more than 0,0762 mm (0.003 inches) thick. In an embodiment of this invention, constructing lance 204 to have a fold angle A3 of about 20° increased the one dimension of the wound size to range from about 0,305 mm (0.012 inches) to about 0,356 mm (0.014 inches) as shown as a distance D4 in Figure 9.

[0054] Figure 9 also illustrates that sharpened tip 214 provides a leading point for piercing a user's skin and that separation tip 206 is tucked under lancing element 208. Thus, because of the positioning of separation tip 206, it does not pierce a user's skin after sharpened tip 214 penetrates the user's skin. If separation tip 206 was orientated in a manner that caused it to pierce the user's skin in addition to lancing element 208, this would cause lance 204 to require additional force for piercing the user's skin. Therefore, in one embodiment of this invention, separation element 208 may be sufficiently bent towards lancing element 212 such that lancing element 212 protects separation tip 206 from piercing the user's skin. In another embodiment of this invention, lancing element 212 may be sufficiently bent towards separation element 208 such that lancing element 212 protects separation tip 206 from piercing the user's skin.

[0055] Figure 11 is a side plan view of the lance which illustrates a lancing element angle A4 and a separation

element angle A5. Lancing element angle A4 may be formed by a plane substantially coincident with upper chamber wall 218 and a plane substantially coincident with lancing element 212. In an embodiment of the present invention, lancing element angle A4 may range from about 5° to about 15°, and preferably be about 8°. Separation element angle A5 may be formed by a plane substantially coincident with tower chamber wall 220 and a plane substantially coincident with separation element 208. Upper chamber wall 218 and lower chamber wall 220 may be configured such that they are approximately parallel to each other. In an embodiment of the present invention, separation element angle A5 may range from about 0° to about 15°, and preferably be about 8°.

[0056] Figure 12 is an expanded side plan view of the lance which illustrates a position of sharpened tip 214 and separation tip 206 relative to axis Z2. Axis Z2 may represent an approximately center position of lance 204 that coincides with sharpened tip 214. In addition, axis Z2 may also represent a direction in which lance 204 moves when launched towards the user's skin. The direction indicated by axis Z2 may be approximately perpendicular to a surface of the user's skin when lance 204 is about to be launched.

[0057] In an embodiment of this invention, separation element 208 may crossover a plane P1 coincident with sharpened tip 214 and parallel to upper chamber wall 218. In this embodiment, separation tip 206 may be on a side of plane P1 closer to lancing element 212. Separation tip 206 may be either touching lancing element 212 or near lancing element 212 so long as separation tip 206 is on the side of plane P1 closer to lancing element 212. It is an advantage of this embodiment in that separation tip 206 does not pierce the user's skin because it is tucked under and protected by lancing element 212.

[0058] In another embodiment of this invention, separation tip 206 may be partially on a side on a side of plane P1 closer to lancing element 212. Note, that it is possible to have only a portion of separation tip 206 on a side of plane P1 closer to lancing element 212 because separation tip 206 has a finite size. In this embodiment, the separation tip 206 will be partially entering an existing wound created by the lancing element 212 which allows lancing element 212 to partially protect separation tip 206.

[0059] In an embodiment of this invention, lance 204 is launched towards a user's skin. Initially, sharpened tip 214 will pierce or puncture the user's skin to form a wound. Next, lancing element 212 will continue to move into the user's skin causing the wound to expand because the two lancing element sides 213 are slicing the user's skin and spreading the wound. After lancing element 212 has entered the wound, separation element 208 will continue to move in the user's skin also causing the wound to further expand. In addition, the two separation element sides 207 can also slice the user's skin facilitating the expansion and spreading of the wound. Once the wound is sufficiently large, bodily fluid can flow from a distal end

of lance 204 to fill channel 222 and then to a working electrode and a reference electrode used for measuring an analyte. Factors that can cause separation element 208 to increase the amount of wound spreading are an increase in sharpness angle A2, fold angle A3, and/or separation angle A5. However, there may be an unacceptable level of pain if the spreading of the wound became too large. When the wound has been sufficiently spread, fluid can flow from a distal end of lance 204 to a proximal end of fill channel 222.

[0060] In an alternative embodiment to this invention, separation tip 206 can be made dull or blunt because it is not used for piercing the user's skin as long as separation element is tucked under and protected by lancing element 212 during the lancing process.

[0061] It will be recognized that equivalent structures may be substituted for the structured illustrated and described herein and that the described embodiment of the invention is not the only structure which may be employed to implement the claimed invention. In addition, it should be understood that every structure described above has a function and such structure can be referred to as a means for performing that function.

[0062] While preferred embodiments of the present invention have been shown and described herein, it will be obvious to those skilled in the art that such embodiments are provided by way of example only. Numerous variations, changes, and substitutions will now occur to those skilled in the art without departing from the invention.

[0063] It should be understood that various alternatives to the embodiments of the invention described herein may be employed in practicing the invention. It is intended that the following claims define the scope of the invention and that structures within the scope of these claims be covered thereby.

Claims

1. A lance (15; 204) comprising:

a lancing element (22; 212) having a sharpened tip (38; 214);
 a separation element (24; 208) having a separation tip (40; 206), wherein said separation tip (40; 206) is positioned proximal to said sharpened tip (38; 214);
 a connector connecting a proximal portion of said lancing element to a proximal portion of said separation element, said connector forming a fill channel (21); and
 said fill channel (21) comprises an upper chamber wall (220) and a lower chamber wall (218); and

characterized in that said lancing element (22; 212) protects said separation tip (24; 208) from initiating a puncture when launching said lance into a user's skin; and

said upper chamber wall (220) is orientated with respect to said lower chamber wall (218) to form a fold angle (A3), wherein said fold angle (A3) ranges from about 10° to about 30°.

2. The lance according to Claim 1, wherein said lancing element has a sharpness angle (A 1) formed by two lancing element sides, wherein said two lancing element sides converge at a vertex coincident with said sharpened tip, said sharpness angle ranging from about 10° to about 25°.
3. The lance according to Claim 1, wherein said lancing element, said separation element and said fill channel are formed from a single sheet of metal.
4. The lance according to Claim 1, said upper chamber wall (220) being connected to a proximal portion of said lancing element, said lower chamber wall (218) being connected to a proximal portion of said separation element; said lance having a plane approximately parallel to said upper chamber wall and coincident with said sharpened tip, wherein said separation tip is positioned on a side of said plane closer to said upper chamber.
5. The lance according to Claim 1, wherein a space between said lancing element and said separation element forms a gap (42), said gap increasing in size proximal to said separation tip.
6. The lance in accordance with Claim 1, wherein a proximal end of said fill channel is integrated into a sensor strip.
7. A sensor strip comprising:

said lance in accordance with Claim 1;
 a main body; wherein said lance and said main body are formed from a single sheet of material, wherein a proximal end of said lance connects to a distal end of said main body, and a rib (210), wherein said rib is an embossment of said single sheet of material and said rib is deposited on a portion of said proximal end of said lance and on a portion of said distal end of said main body, whereby said rib strengthens a bending rigidity of said lance with respect to said main body.

Patentansprüche

1. Lanze (15; 204), die aufweist:

ein Stechelement (22; 212) mit einer geschärften Spitze (38; 214);

ein Trennelement (24; 208) mit einer Trennspitze (40; 206), wobei die Trennspitze (40; 206) proximal zu der geschärften Spitze (38; 214) angeordnet ist;

einen Verbinder, der einen proximalen Bereich des Stechelementes mit einem proximalen Bereich des Trennelementes verbindet, wobei der Verbinder einen Füllkanal (21) bildet; und der Füllkanal (21) eine obere Kammerwand (220) und eine untere Kammerwand (218) aufweist; und

dadurch gekennzeichnet, dass das Stechelement (22; 212) die Trennspitze (24; 208) vor dem Einleiten eines Stiches schützt, wenn die Lanze in die Haut eines Benutzers gebracht wird; und

die obere Kammerwand (220) in Bezug auf die untere Kammerwand (218) ausgerichtet ist, um einen Faltungswinkel (A3) zu bilden, wobei der Faltungswinkel (A3) im Bereich von ungefähr 10° bis ungefähr 30° liegt.

2. Lanze nach Anspruch 1, bei der das Stechelement einen Schärfe Winkel (A1) hat, der durch zwei Seiten des Stechelementes gebildet ist, wobei die zwei Seiten des Stechelementes an einem Scheitelpunkt zusammenlaufen, der mit der geschärften Spitze übereinstimmt, wobei der Schärfe Winkel im Bereich von ungefähr 10° bis ungefähr 25° liegt.
3. Lanze nach Anspruch 1, bei der das Stechelement, das Trennelement und der Füllkanal aus einem einzigen Metallblech gebildet sind.
4. Lanze nach Anspruch 1, bei der die obere Kammerwand (220) mit einem proximalen Bereich des Stechelementes verbunden ist; die untere Kammerwand (218) mit einem proximalen Bereich des Trennelementes verbunden ist; die Lanze eine Ebene hat, die ungefähr parallel zu der oberen Kammerwand ist und mit der geschärften Spitze zusammenfällt, wobei die Trennspitze auf einer Seite der Ebene näher an der oberen Kammer angeordnet ist.
5. Lanze nach Anspruch 1, bei der ein Raum zwischen dem Stechelement und dem Trennelement einen Spalt (42) bildet, wobei der Spalt in der Größe proximal zu der Trennspitze zunimmt.
6. Lanze nach Anspruch 1, bei der ein proximales Ende des Füllkanals in einen Sensorstreifen integriert ist.
7. Sensorstreifen, der aufweist:

die Lanze nach Anspruch 1;
 ein Hauptgehäuse; wobei die Lanze und das Hauptgehäuse aus einem einzigen Materi-

alblech gebildet sind, wobei ein proximales Ende der Lanze an ein distales Ende des Hauptgehäuses anschließt, und eine Rippe (210), wobei die Rippe eine Prägung des einzigen Materialbleches ist und die Rippe auf einem Bereich des proximalen Endes der Lanze und auf einem Bereich des distalen Endes des Hauptgehäuses angeordnet ist, wobei die Rippe eine Biegefestigkeit der Lanze in Bezug auf das Hauptgehäuse verstärkt.

Revendications

1. Lancette (15; 204) comprenant:

un élément de lancement (22; 212) ayant une pointe affûtée (38; 214);

un élément de séparation (24; 208) ayant une pointe de séparation (40; 206), où ladite pointe de séparation (40; 206) est positionnée proximale-ment à ladite pointe affûtée (38; 214);

un connecteur reliant une portion proximale dudit élément de lancement à une portion proximale dudit élément de séparation, ledit connecteur formant un canal de remplissage (21); et ledit canal de remplissage (21) comprend une paroi de chambre supérieure (220) et une paroi de chambre inférieure (218); et

caractérisée en ce que ledit élément de lancement (22; 212) protège ladite pointe de séparation (24; 208) d'initier une ponction lors du lancement de ladite lancette dans la peau d'un utilisateur; et

ladite paroi de chambre supérieure (220) est orientée par rapport à ladite paroi de chambre inférieure (218) pour former un angle de pliage (A3), où ledit angle de pliage (A3) s'étend sur environ 10° à environ 30°.

2. Lancette selon la revendication 1, où ledit élément de lancement possède un angle tranchant (A1) formé par deux côtés de l'élément de lancement, où lesdits deux côtés de l'élément de lancement convergent à un sommet coïncidant avec ladite pointe affûtée, ledit angle tranchant étant d'environ 10° à environ 25°.

3. Lancette selon la revendication 1, où ledit élément de lancement, ledit élément de séparation et ledit canal de remplissage sont réalisés en une seule feuille de métal.

4. Lancette selon la revendication 1, ladite paroi de chambre supérieure (220) étant reliée à une portion proximale dudit élément de lancement, ladite paroi de chambre inférieure (218) étant reliée à une portion proximale dudit élément de séparation;

ladite lancette ayant un plan approximativement parallèle à ladite paroi de chambre supérieure et coïncidant avec ladite pointe affûtée;

où ladite pointe de séparation est positionnée sur un côté dudit plan plus proche de ladite chambre supérieure.

5. Lancette selon la revendication 1, dans laquelle un espace entre ledit élément de lancement et ledit élément de séparation forme un intervalle (42), ledit intervalle augmentant en taille proximale-ment à ladite pointe de séparation.

6. Lancette selon la revendication 1, où une extrémité proximale dudit canal de remplissage est intégrée dans une bande de détection.

7. Bande de détection comprenant:

ladite lancette selon la revendication 1;

un corps principal; où ladite lancette et ledit corps principal sont réalisés à partir d'une seule feuille de matériau, où une extrémité proximale de ladite lancette est reliée à une extrémité distale dudit corps principal, et une nervure (210), où ladite nervure est un bosselage de ladite feuille de matériau unique, et ladite nervure est déposée sur une portion de ladite extrémité proximale de ladite lancette et sur une portion de ladite extrémité distale dudit corps principal, moyennant quoi ladite nervure renforce une rigidité en flexion de ladite lancette par rapport audit corps principal.

FIG. 1

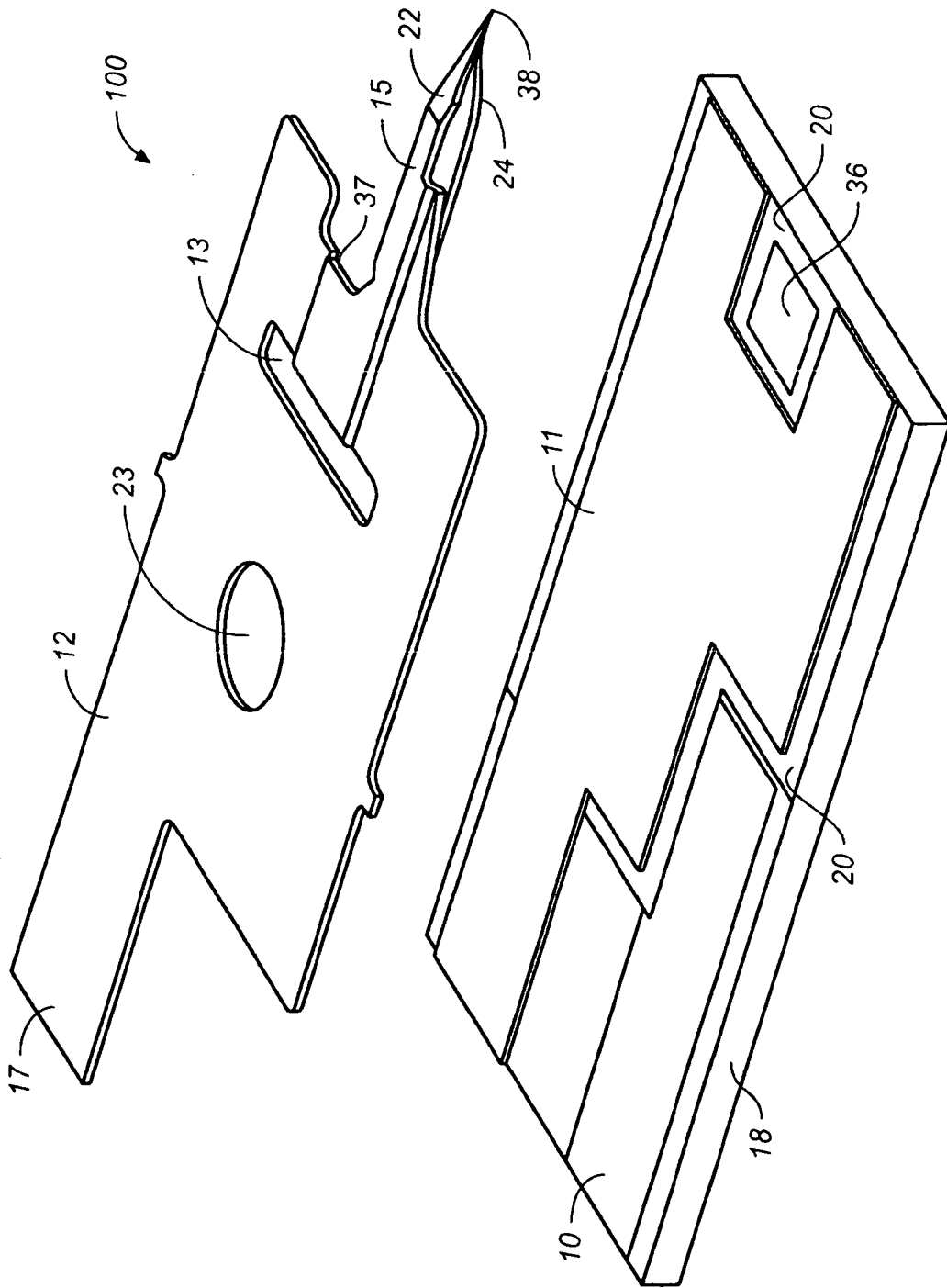

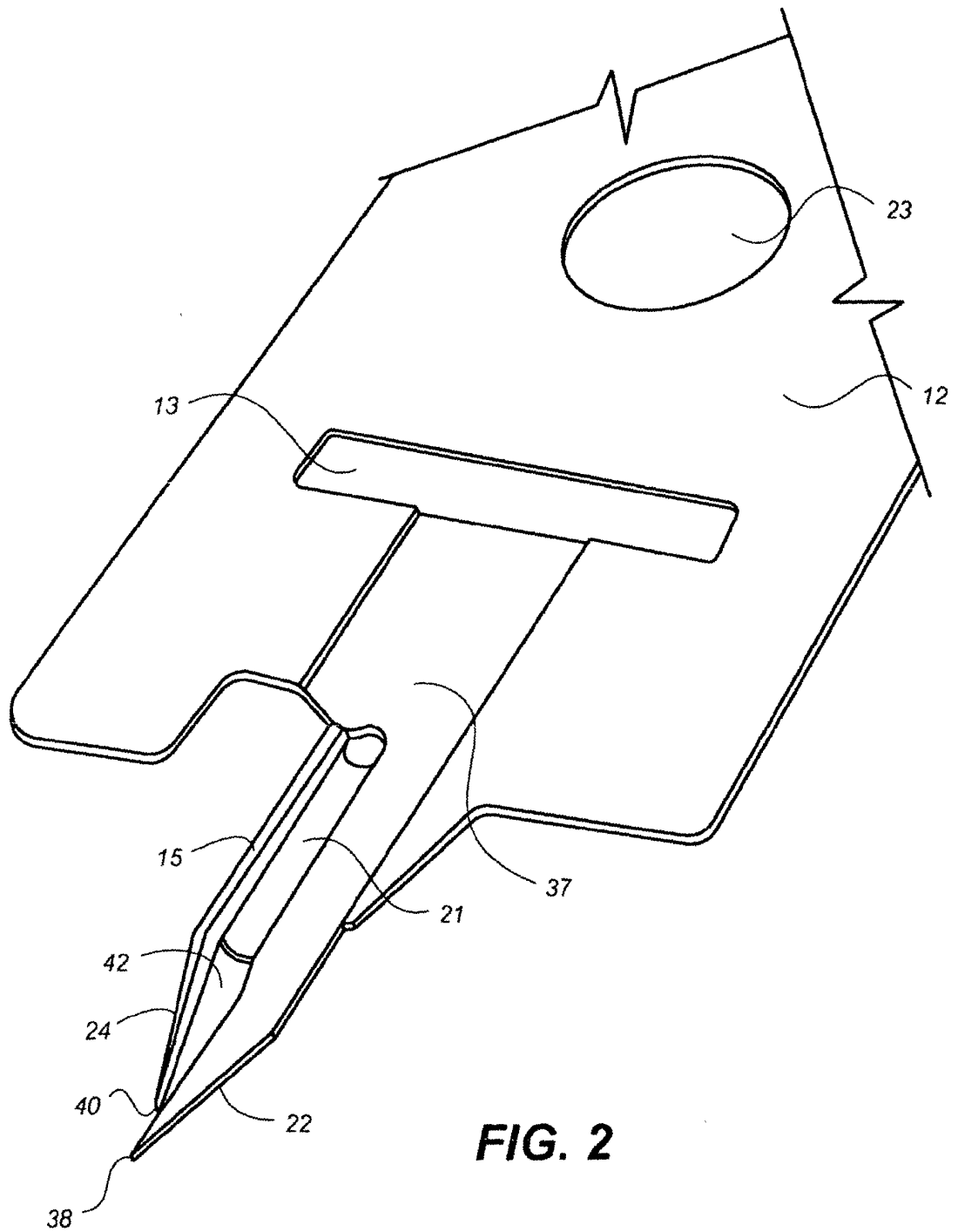

FIG. 2

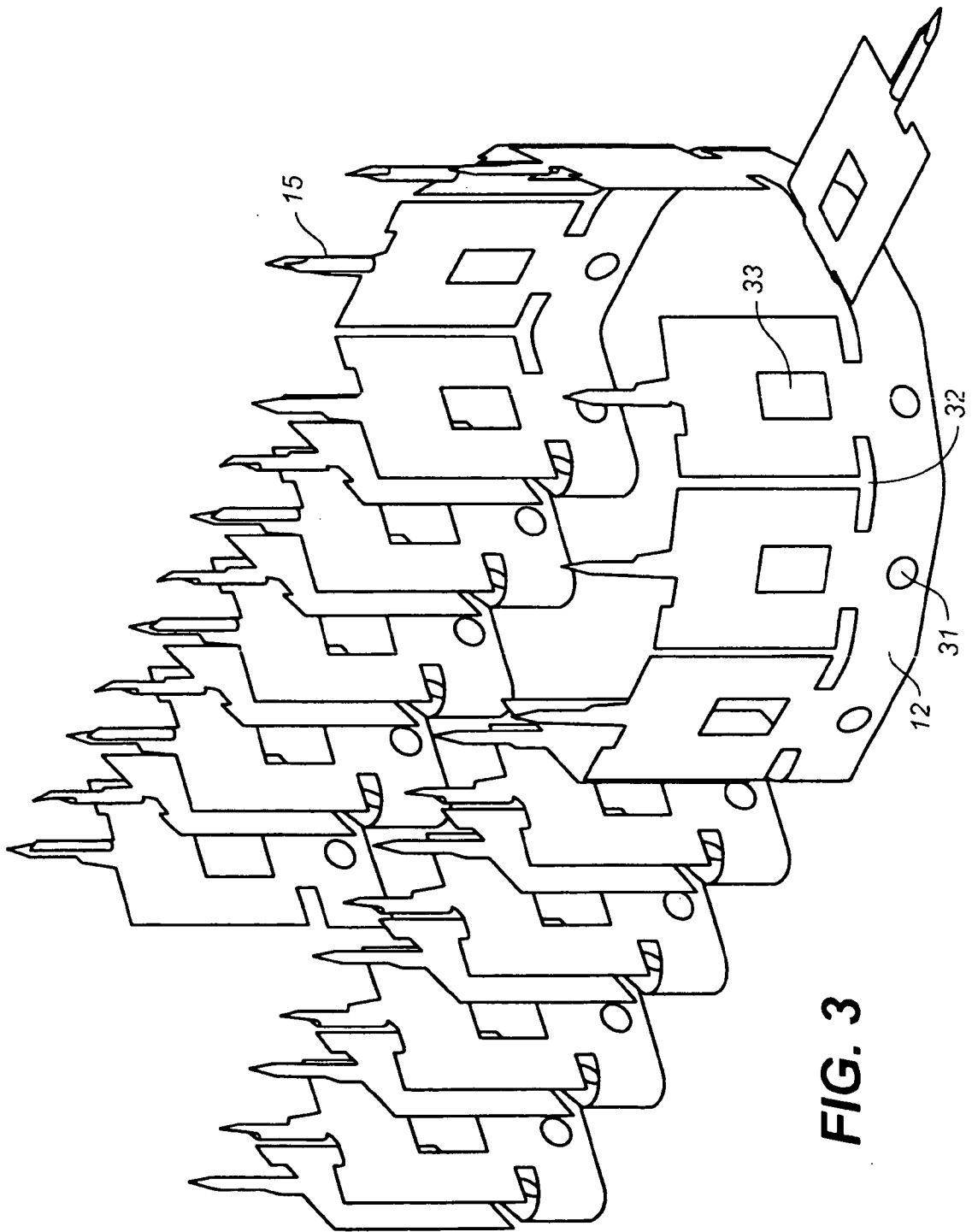

FIG. 3

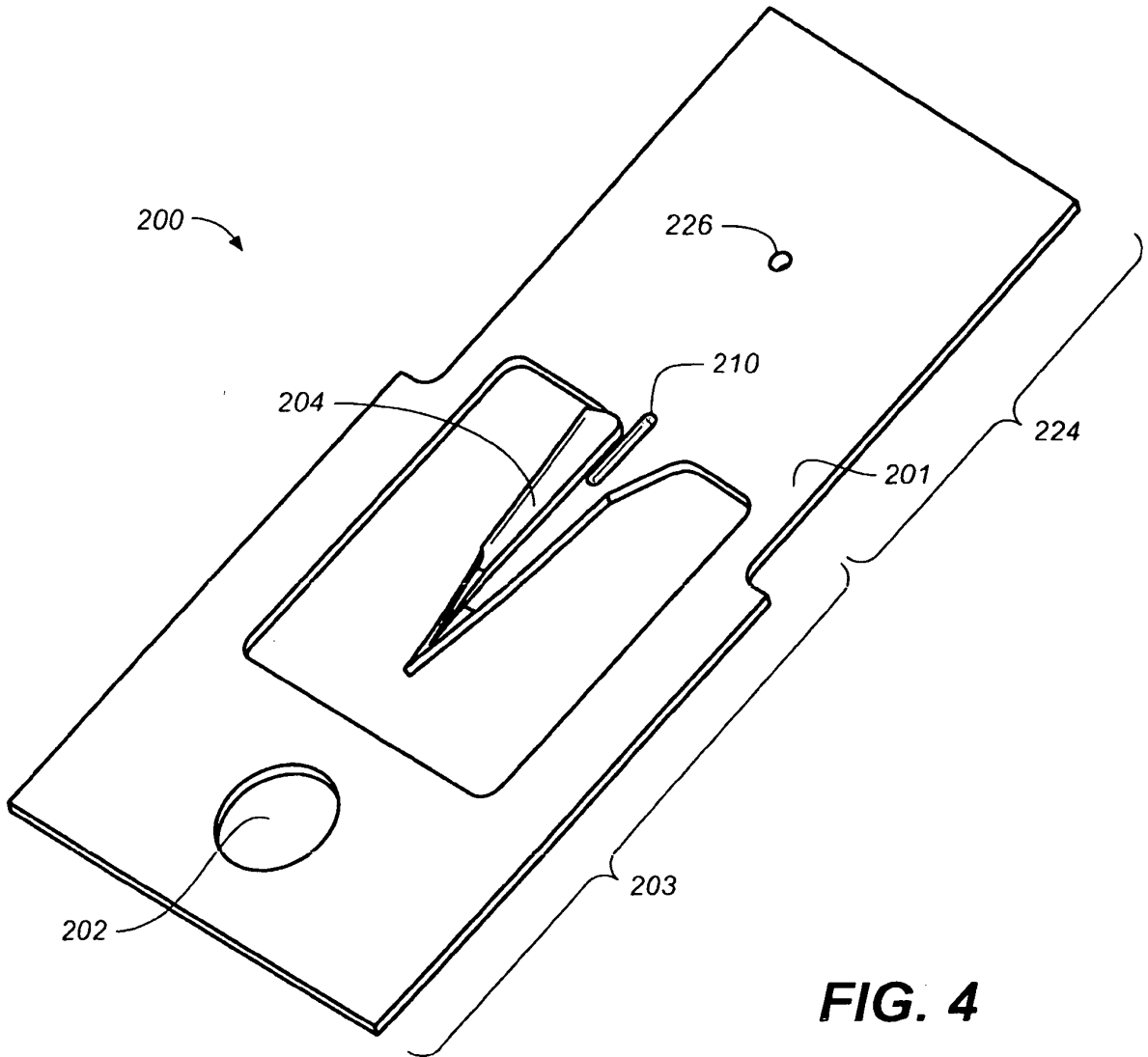

FIG. 4

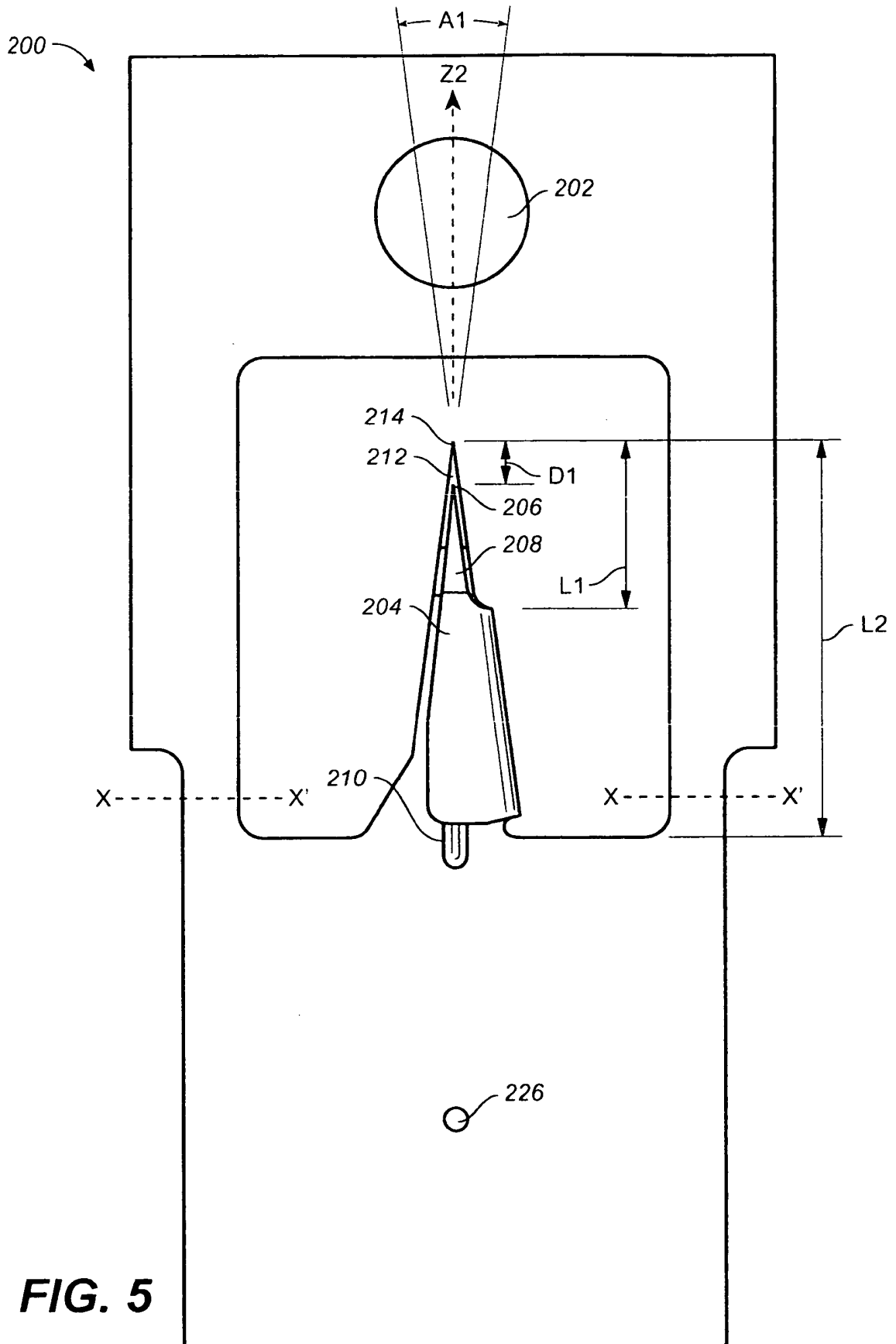

FIG. 5

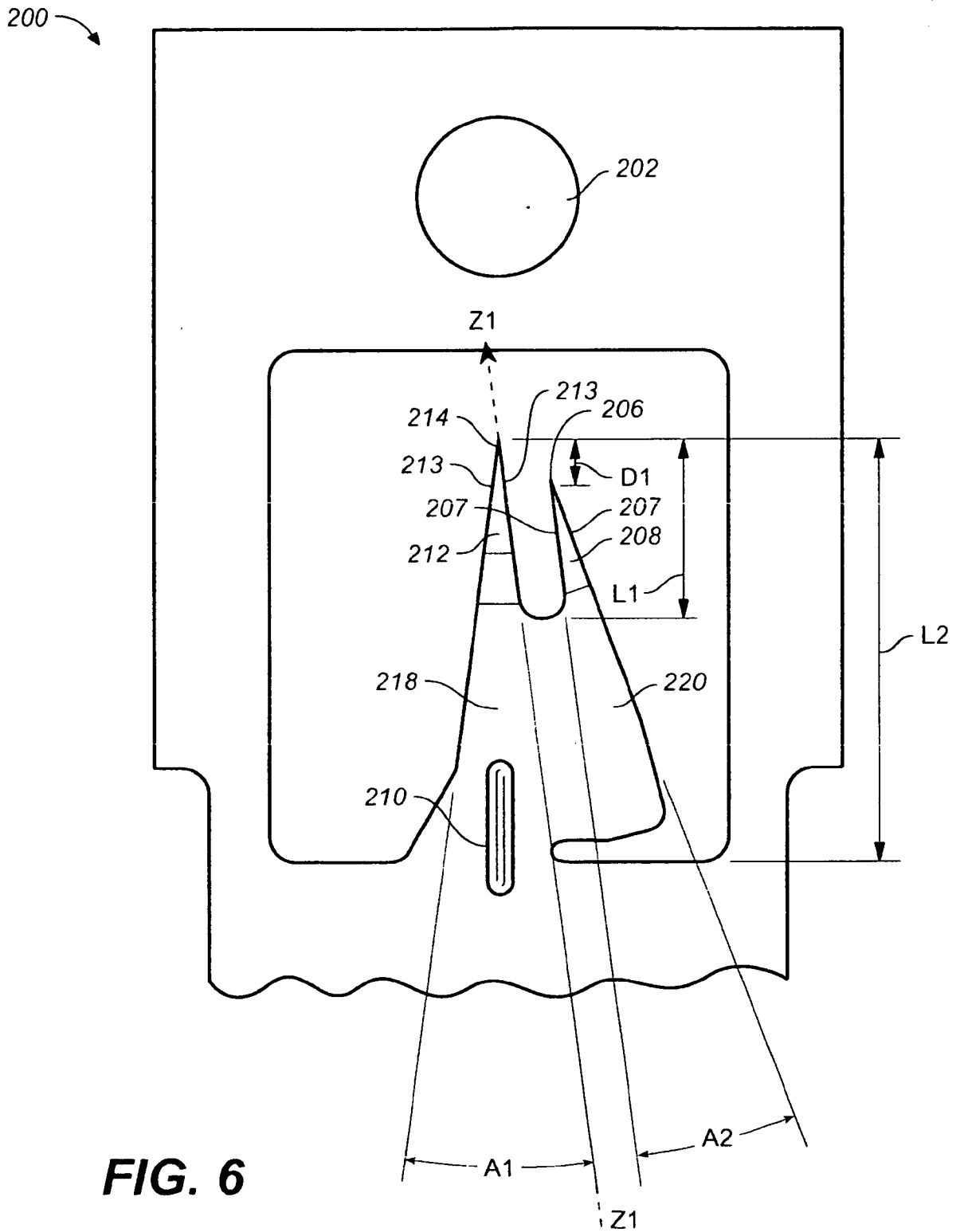

FIG. 6

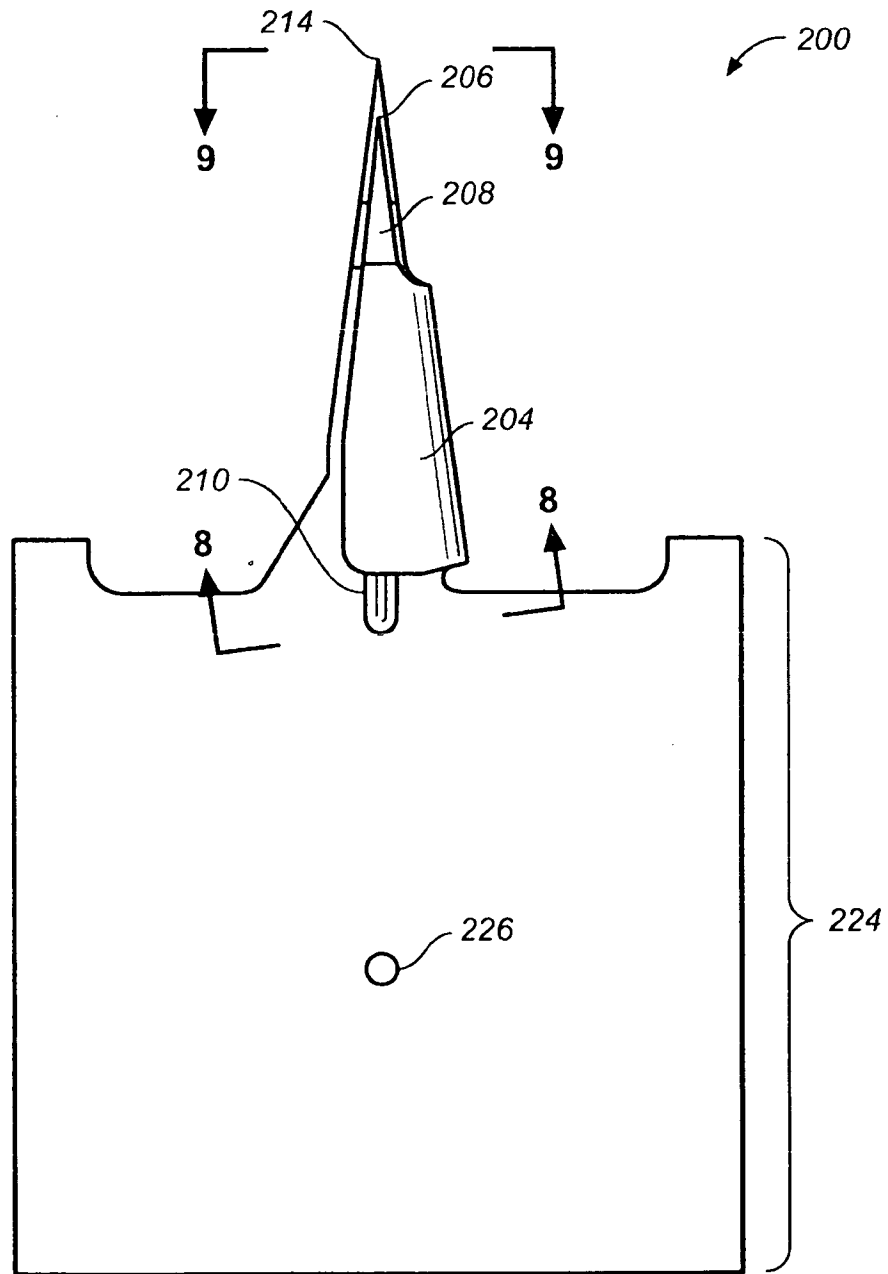

FIG. 7

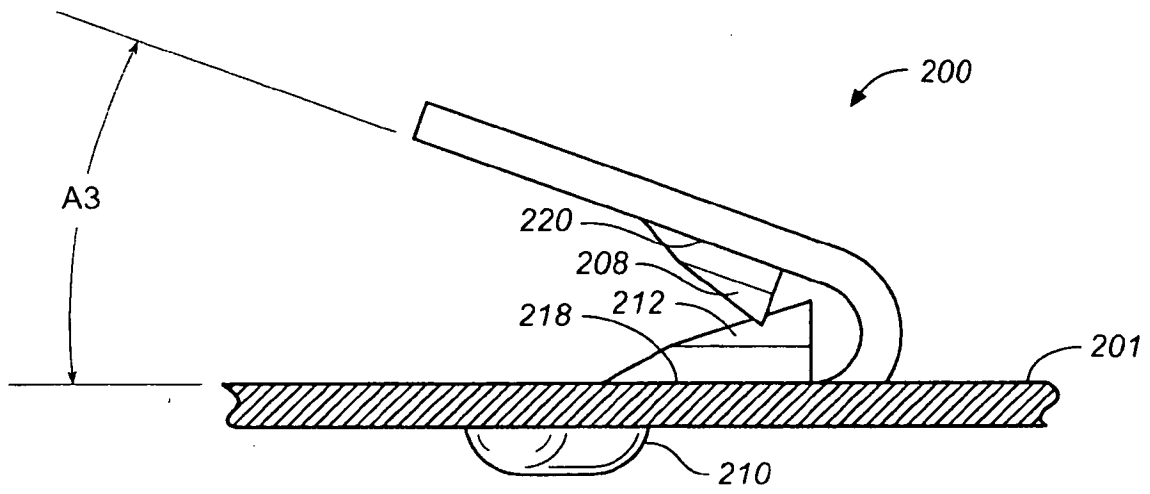

FIG. 8

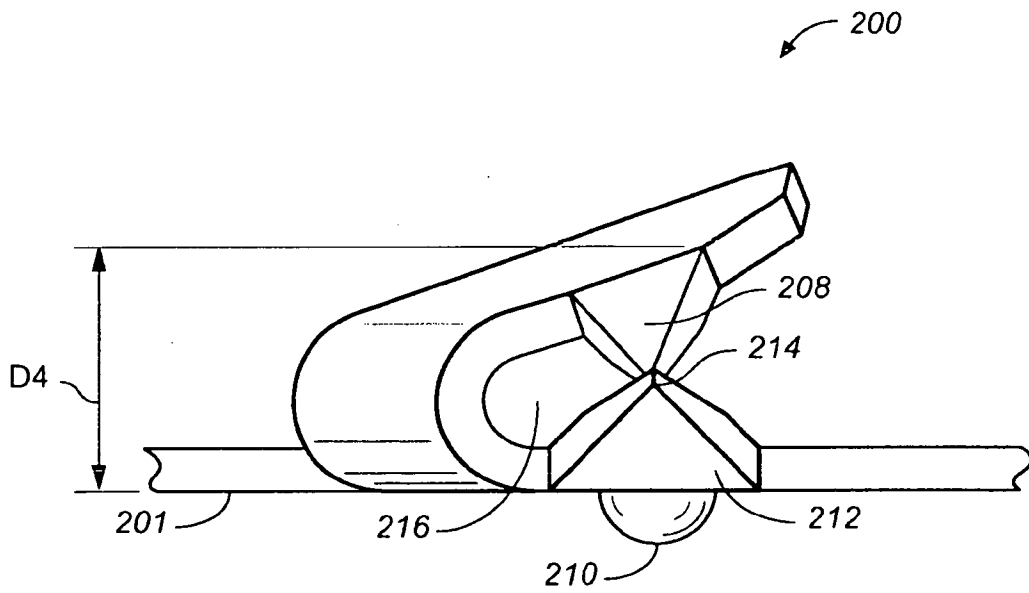

FIG. 9

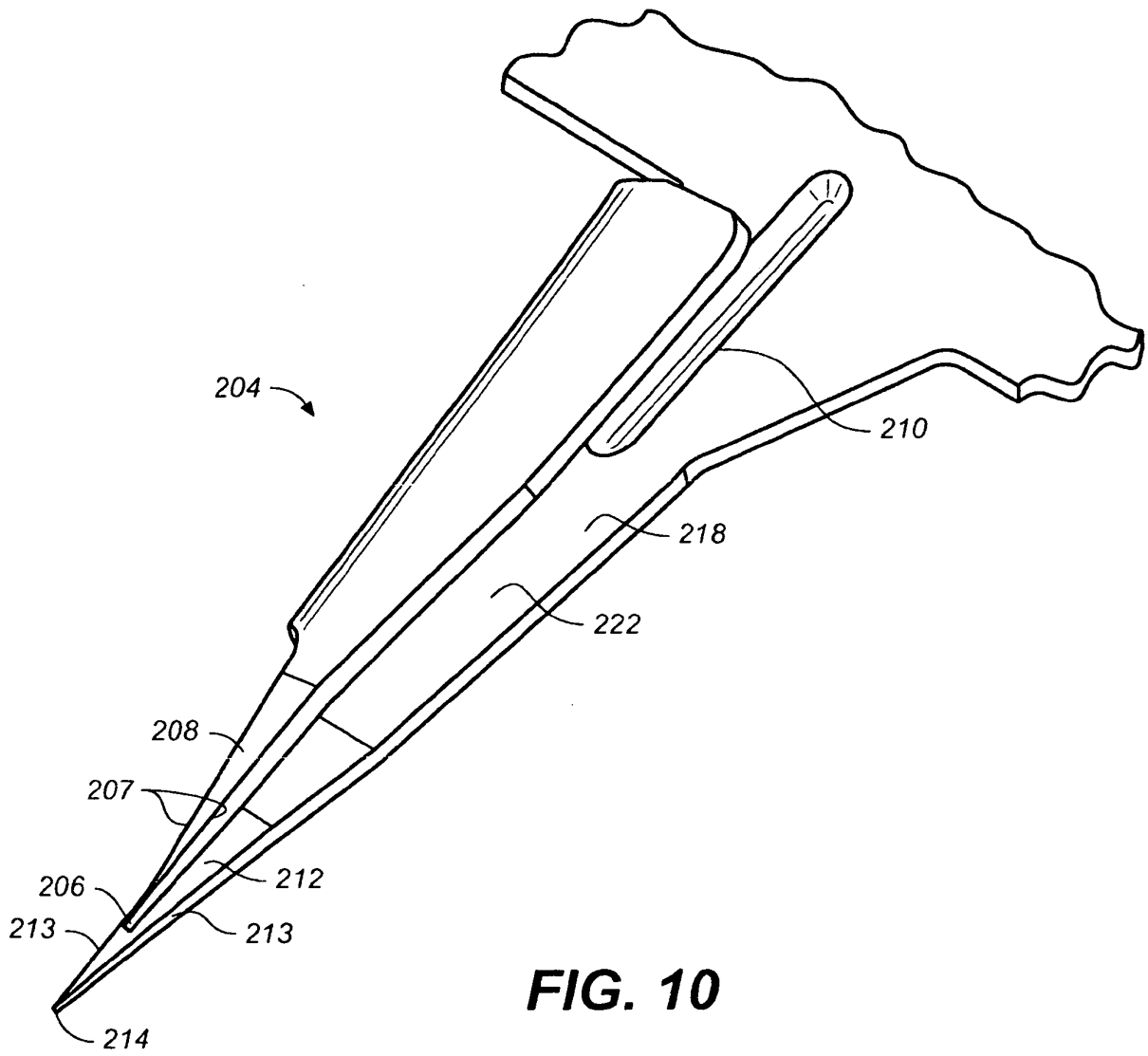

FIG. 10

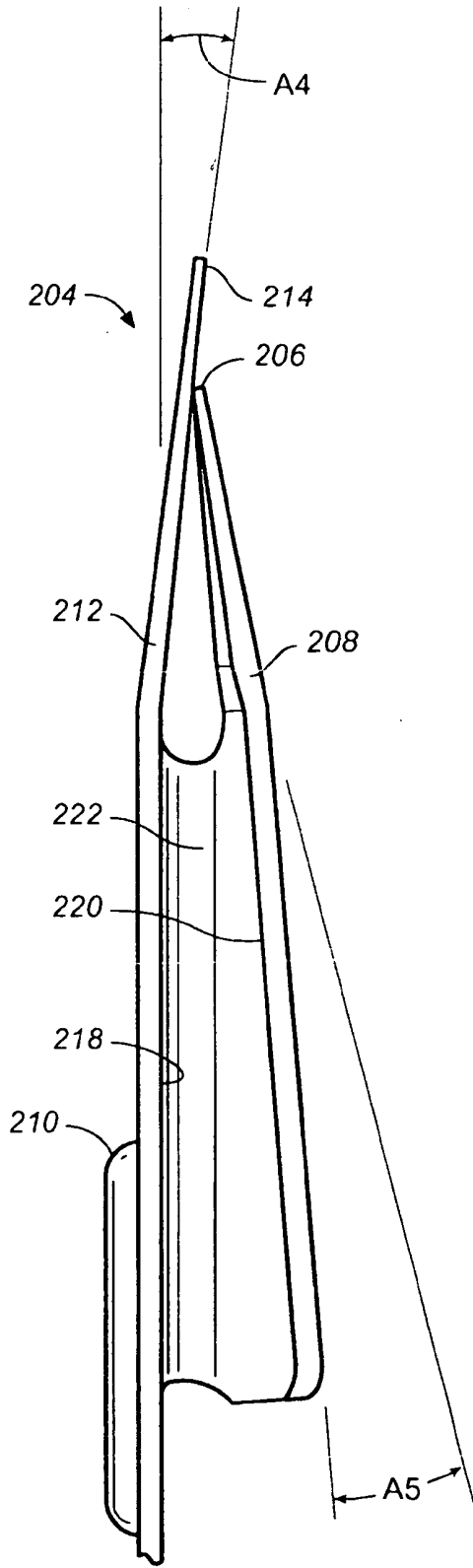

FIG. 11

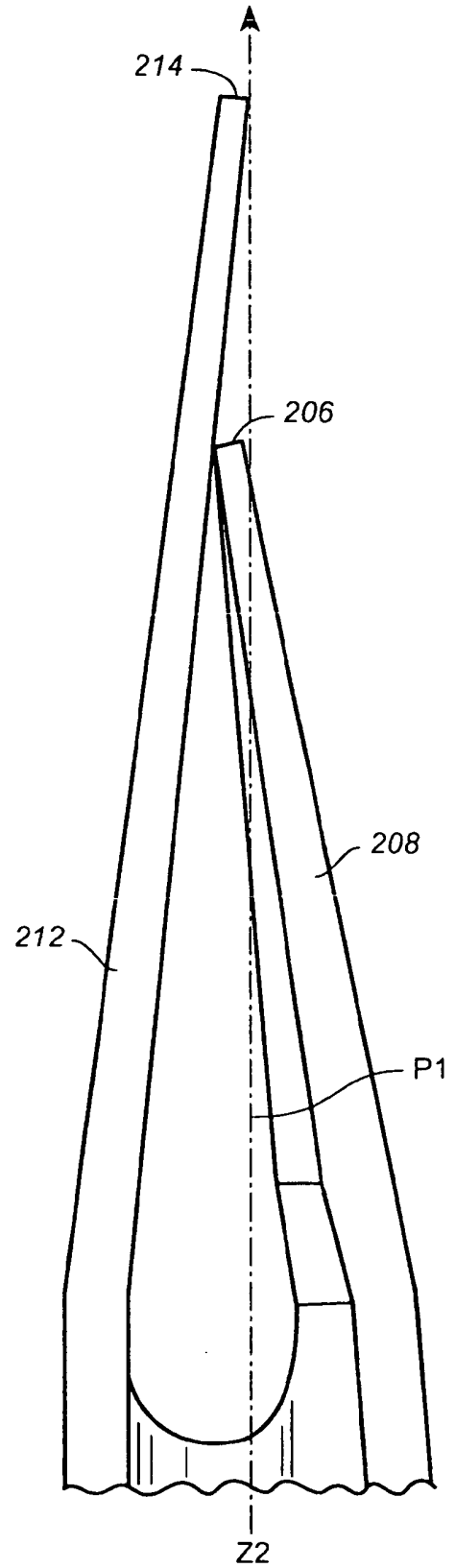

FIG. 12

REFERENCES CITED IN THE DESCRIPTION

This list of references cited by the applicant is for the reader's convenience only. It does not form part of the European patent document. Even though great care has been taken in compiling the references, errors or omissions cannot be excluded and the EPO disclaims all liability in this regard.

Patent documents cited in the description

- WO 0249507 A [0002]
- WO 2004041088 A [0005]
- EP 1462053 A [0005]

专利名称(译)	用于分析物测量的集成喷枪和条带		
公开(公告)号	EP1774908B1	公开(公告)日	2011-04-06
申请号	EP2006255275	申请日	2006-10-13
[标]申请(专利权)人(译)	生命扫描有限公司		
申请(专利权)人(译)	LIFESCAN INC.		
当前申请(专利权)人(译)	LIFESCAN INC.		
[标]发明人	ALLEN JOHN J		
发明人	ALLEN, JOHN J.		
IPC分类号	A61B5/151 A61B10/00 A61B5/00 A61B5/15 A61B5/155 A61B17/32		
CPC分类号	A61B5/15167 A61B5/02035 A61B5/14514 A61B5/14532 A61B5/1486 A61B5/150022 A61B5/150213 A61B5/150282 A61B5/150358 A61B5/15045 A61B5/150458 A61B5/150465 A61B5/150511 A61B5/6848 A61B10/0045 A61B17/32093 A61B2010/008 A61B2562/0295		
优先权	11/251189 2005-10-14 US		
其他公开文献	EP1774908A2 EP1774908A3		
外部链接	Espacenet		

摘要(译)

本发明一般涉及用于从体内抽出体液的刺血元件，更具体地说，涉及一种改进的刺血元件，其包括相对于彼此定位的第一和第二元件，使得由第一元件形成的切口通过第二元件保持打开，并且通过第一和第二刺血元件上的表面张力将体液拉到刺血元件上。

