



(11) **EP 1 327 418 B1**

(12) **EUROPEAN PATENT SPECIFICATION**

(45) Date of publication and mention of the grant of the patent:  
**19.05.2010 Bulletin 2010/20**

(21) Application number: **01974872.2**

(22) Date of filing: **16.10.2001**

(51) Int Cl.:  
**A61B 10/00 (2006.01) A61B 5/00 (2006.01)**

(86) International application number:  
**PCT/JP2001/009064**

(87) International publication number:  
**WO 2002/032317 (25.04.2002 Gazette 2002/17)**

(54) **ORGANISM OPTICAL MEASUREMENT INSTRUMENT**

OPTISCHES ORGANISMUSMESSGERÄT

INSTRUMENT DE MESURE OPTIQUE D'ORGANISMES

(84) Designated Contracting States:  
**DE FR GB IT NL**

(30) Priority: **16.10.2000 JP 2000315115**

(43) Date of publication of application:  
**16.07.2003 Bulletin 2003/29**

(73) Proprietor: **HITACHI MEDICAL CORPORATION**  
**Tokyo 100-0047 (JP)**

(72) Inventors:  
• **KAWASAKI, Shingo**  
**Matsudo-shi, Chiba 270-2203 (JP)**  
• **WATANABE, Eiju**  
**Bunkyo-ku, Tokyo 113-0033 (JP)**

(74) Representative: **Strehl Schübel-Hopf & Partner**  
**Maximilianstrasse 54**  
**80538 München (DE)**

(56) References cited:  
**WO-A-99/40841 GB-A- 2 311 854**  
**JP-A- 9 098 972 JP-A- 9 135 825**  
**JP-A- 2000 237 194 US-A- 5 803 909**

- **PATENT ABSTRACTS OF JAPAN vol. 1997, no. 08, 29 August 1997 (1997-08-29) & JP 09 098972 A (HITACHI LTD), 15 April 1997 (1997-04-15)**
- **PATENT ABSTRACTS OF JAPAN vol. 1997, no. 09, 30 September 1997 (1997-09-30) & JP 09 135825 A (HITACHI LTD), 27 May 1997 (1997-05-27)**

**EP 1 327 418 B1**

Note: Within nine months of the publication of the mention of the grant of the European patent in the European Patent Bulletin, any person may give notice to the European Patent Office of opposition to that patent, in accordance with the Implementing Regulations. Notice of opposition shall not be deemed to have been filed until the opposition fee has been paid. (Art. 99(1) European Patent Convention).

## Description

### FIELD OF THE INVENTION

**[0001]** The present invention relates to an optical measurement apparatus for living body; and more particularly, the invention relates to a technique effective in observing areas where there is response by the object to be examined to outside stimulation.

### BACKGROUND OF THE INVENTION

**[0002]** In recent years, the optical measurement apparatus for living body has been developed, by which functions of tissue in a living body are observed by transmitting laser light to the interior of the living body and detecting signals generated due to interaction between the laser and hemoglobin in the blood flow within the living body. Such an optical measurement apparatus for living body is disclosed, for example, in Japanese Patent Laid-open Publication JP-A-9-98972 (hereinafter referred to as "document 1"). The optical measurement apparatus for living body mentioned therein is constituted of modulated semiconductor laser devices for generating light having various modulation frequencies, light-transmitting optical fibers for guiding the light generated by the semiconductor laser devices to transmit light to a plurality of positions, detecting optical fibers for collecting the light which has passed through the living body (hereinafter referred to as "living-body transillumination") and guiding it to photodiodes, a fixing member for fixing the tips of the light-transmitting optical fibers and the detecting optical fibers to predetermined positions on the living body, lock-in amplifiers for separating electric signals of the optical intensity of the living-body transillumination which are output from the photodiodes (hereinafter referred to as "living-body transillumination intensity signals") according to wavelength and measurement position, an A/D converter for converting the outputs of the lock-in amplifiers into digital signals, an input/output unit having an image generation unit for generating an image of the living-body transillumination intensity signal (a topography image) corresponding to variations of hemoglobin concentration at each measuring point from the living-body transillumination intensity signals after A/D conversion, and an image display unit for inputting operation instruction for the apparatus and displaying the living-body transillumination intensity signal image. In this specification, "transillumination" hereinafter means any kind of light including transmitted light, reflected light, and scattered light which are generated at a light source and detected at a detector (a light detector) after interacting with the living body.

**[0003]** In the measurement using the conventional optical measurement apparatus for living body described above, the fixing member is first put on the living body, and the light-transmitting optical fibers and the detecting optical fibers supported by a probe holder provided to

the fixing member are applied to predetermined positions on the living body. Then, in preliminary measurement, for example, plural measurements of 10 seconds each, living-body transillumination intensity signals in the resting state, are measured, and the measured values are averaged to calculate hemoglobin concentration in measured areas of the living body in the resting state. Next, the living-body transillumination intensity signals are measured in the state where stimulation is applied to the living body.

**[0004]** Then, relative variations of oxygenated hemoglobin concentration and relative variations of deoxygenated hemoglobin concentration are calculated at each measuring point from the measured living-body transillumination intensity signals in the resting state and the measured living-body transillumination intensity signals in the state where stimulation is applied. An image of the living-body transillumination intensity signal is generated from the relative variations of oxygenated hemoglobin concentration, the relative variations of deoxygenated hemoglobin concentration, and the relative variations of total hemoglobin concentration which is the sum of the relative variations of oxygenated hemoglobin concentration and deoxygenated hemoglobin concentration, and this image is displayed.

**[0005]** To describe in detail the mode of image display in the conventional optical measurement apparatus for living body, relative variations of oxygenated hemoglobin concentration, relative variations of deoxygenated hemoglobin concentration, and relative variations of the total hemoglobin concentration are calculated at each measuring point from the living-body transillumination intensity signal acquired at a measuring point (a position to be measured) which is the area between a pair of the light-transmitting optical fiber and the detecting optical fiber which are adjacently placed. The relative variations of oxygenated hemoglobin concentration and the relative variations of deoxygenated hemoglobin for each pixel are calculated by spline interpolation and the like from the relative variations of oxygenated hemoglobin concentration and the relative variations of deoxygenated hemoglobin concentration obtained at each measuring point. When the result thereof is displayed as an image, the area where the variation is minimum among those relative variations is provided with blue hue, the area where the variation is maximum is provided with red hue, and areas between them are provided with medium hues between blue and red in accordance with their variation. The area where the variation of hemoglobin concentration is maximum represents the area which has been activated by the application of stimulation. In this manner, the area which has been activated by stimulation, that is, the functioning area of the living body is identified by the variations of hemoglobin concentration in the measuring area.

**[0006]** After considering the above-described conventional technique, the inventor found a problem. That is, to take therapy of epilepsy as an example, the therapy

in which the focal point of epilepsy is identified and is excised requires not only accurate identification of the focal point of epilepsy, but also accurate identification of positions of a speech function area (the "speech area"), a visual function area ("the optic area") and the like. The reason thereof is to enable exsection of the focal point of epilepsy to maximum while reducing damage to the speech area and the visual area to minimum, by identifying the accurate position of the speech area and the visual area, and thus improve treatment outcome.

**[0007]** On the other hand, to accurately identify the areas where the relative variations of hemoglobin concentration greatly changes (the focal point of epilepsy), it is necessary to identify the measuring point having the largest relative variations of hemoglobin concentration and the areas around it having large relative variations. However, when the relative variations of hemoglobin concentration are displayed with colors as in the conventional optical measurement apparatus for living body, the area to be examined might depend on the difference of the examiner's sensitivity to colors. Therefore, a display method by which the examiner can objectively identify the area where the relative variation of hemoglobin concentration is greatest has been desired.

#### SUMMARY OF THE INVENTION

**[0008]** An object of the invention is to provide a technique by which efficiency of diagnosis using an optical measurement apparatus for a living body can be improved.

**[0009]** This object is solved by an optical measurement apparatus in accordance with claim 1. The dependent claims relate to preferred embodiments of the invention.

**[0010]** The above-described and other objects and the novel features of the invention will be revealed in the description of the specification and the attached drawings.

**[0011]** An embodiment of the present invention provides an optical measurement apparatus for living body constituted of light transmitting means for transmitting light to a plurality of positions in the area of a living body under examination; light detecting means for detecting at a plurality of positions in the area under examination the light which has been transmitted by the light transmitting means and has passed through the living body; load applying means for applying to the living body a load to which the living body responds; means for generating signals representing intensity change of transillumination detected by the light detecting means at measuring points which are determined based on positional relation between each of the light transmitting means and the light detecting means, during both a period in which the load is applied to the living body and a period in which the load is not being applied; means for converting time variations of at least one signal among two signals detected above and time variations of the light signal at each measuring point into time variations of hemoglobin

concentration; means for calculating the time variations of hemoglobin concentration calculated at the measuring points, determined based on the positional relation between each of the light transmitting means and the light detecting means; and display control means for displaying graphs of the time variations of hemoglobin concentration in correspondence with the positional relation between each of the light transmitting means and the light detecting means.

**[0012]** The optical measurement apparatus further includes means for selecting and classifying graphs displayed on display means by the display control means into a plurality of groups.

**[0013]** The optical measurement apparatus further includes means for distinguishably displaying the respective graphs of the groups to be displayed classified by the selecting means.

**[0014]** Further, the optical measurement apparatus for a living body desirably includes means for displaying on the display means a particular group among the plurality of groups classified by the selecting means.

**[0015]** Also, the apparatus includes means for averaging measured values of the respective groups classified by the selecting means, and means for displaying on the displaying means data of the respective groups of the values. Further, the apparatus desirably includes means for converting the average values calculated by the averaging means into data displayed as graphs on the display means.

**[0016]** The optical measurement apparatus for a living body desirably includes means for calculating a correlation between standard data representing characteristics of one selected group and the data calculated by the averaging means, and means for displaying a value of the calculated correlation near the displayed graph. Further, it is preferable that the standard data representing the characteristics of one selected group is stored in storing means, and the stored standard data is read out by readout means.

**[0017]** Further, the optical measurement apparatus for a living body desirably includes means for inputting the standard data representing the characteristics of one selected group, and the standard data inputting means desirably includes an operation device for inputting a plurality of coordinate points on a coordinate plane having two axes, for signal intensity and for time, on a screen of the display means, means for calculating by interpolation processing the coordinate points between the respective coordinate points input by the operation device, and means for generating a correlation standard graph from the input coordinate points and the coordinate points calculated by the interpolation processing. Further, the standard data inputting means desirably includes means for converting signal intensity and time of the coordinate points input by the operation device into numerical values, and displaying the values as a chart.

**[0018]** Further, the optical measurement apparatus for a living body desirably includes means for calculating a

difference value between the average value of measured values in the period in which the load is applied to the living body and the average value of measured values in the period when the load is not applied to the living body, and means for displaying the difference value calculated by the difference calculating means in the vicinity of the displayed graph.

**[0019]** The optical measurement apparatus may also be constituted of a plurality of light-transmitters for transmitting light, which are discretely placed on plural positions on the head of a living body; a plurality of light detectors for detecting light which has been transmitted by the light-transmitter placed discretely on plural positions on the head of the living body and which has passed through the living body, the light detectors being placed alternately with the light-transmitters; load applying means for applying a load to which the living body responds when applied; preliminary measurement means for performing preliminary measurement during the period when the load is not applied to the living body, in order to measure a standard signal; actual measurement means for performing actual measurement which has a rest period in which the load is not applied to the living body and a loading period in which the load is applied to the living body by the load applying means, so as to measure a signal representing intensity change of the transillumination detected by the light detecting means; means for calculating relative variations of the signal measured in the actual measurement with respect to the standard signal by comparing the signal calculated above and the standard signal; and display control means for displaying graphs of the above-calculated relative variations in correspondence with the measuring points determined based on the positional relation between each of the light transmitting means and the light detecting means.

**[0020]** Further, the optical measurement apparatus for a living body may be constituted of light transmitting means for transmitting light to a plurality of positions on the body surface corresponding to the areas to be examined in the living body; light detecting means for detecting optical intensity of the light which has been transmitted by the light transmitting means and which has passed through the living body at the plurality of positions on the surface of the living body; means for converting time variations of the intensity of transillumination detected by the detecting means into time variations of hemoglobin concentration and making graph data of this time variations of hemoglobin concentration; and means for displaying the graph data at display positions corresponding to the measured points which are determined based on the positional relation between each of the light transmitting means and the light detecting means.

#### BRIEF DESCRIPTION OF THE DRAWINGS

##### **[0021]**

Fig. 1 is a diagram illustrating outline structure of an

optical measurement apparatus for living body according to one embodiment of the present invention. Fig.2 is a flow chart showing the process of the living-body optical measurement using an optical measurement apparatus for living body according to this embodiment.

Fig.3 is a diagram showing positions of measuring points on the right brain and the left brain.

Fig.4 is a diagram showing fixing points of optical fibers for illumination and for detection by which the measuring points shown in Fig.3 are determined.

Fig.5 is a diagram showing one example of displaying graphs representing relative variations of measured hemoglobin concentration.

Fig.6 is a diagram showing one example of displaying graphs representing relative variations of hemoglobin concentration in the same function area.

Fig.7 is a diagram showing one example of display in which relative variations of hemoglobin concentration in the same function area and correlation values on correlation graphs are represented together with the graph.

Fig. 8 is a diagram showing one example of displaying difference values between the loading period and the rest period along with graphs representing relative variations of hemoglobin concentration in the same function area.

Fig.9 is a diagram illustrating process of setting a correlation graph in the optical measurement apparatus for living body according to the embodiment of the present invention.

#### BEST MODE FOR CARRYING OUT THE INVENTION

**[0022]** Hereinafter, an embodiment of the present invention is described in detail with reference to the drawings. Incidentally, throughout the drawings for describing the embodiment of the invention, elements having the same function are provided with the same reference numbers respectively.

**[0023]** Fig. 1 is a block diagram illustrating the outline structure of an optical measurement apparatus for living body according to the embodiment of the invention. In Fig.1, reference number 1 represents a light source unit, reference number 2 represents light modules, reference number 3 represents semiconductor laser devices, reference number 8 represents optical fibers for illumination, reference number 9 represents an object to be examined, reference number 10 represents optical fibers for detection, reference number 11 represents photodiodes, reference number 12 represents a rock-in amplifier module, reference number 16 represents an A/D converter, reference number 17 represents a control unit (CPU), reference number 18 represents storing means, reference number 19 represents processing means, reference number 20 represents an input/output unit (display control unit), and reference represents number 21 represents an image generation unit. Incidentally, among

the above-mentioned constituent features, all features except the control unit 17, the processing means 19, the input/output unit 20 and the image generation unit 21 are similar to those in known optical measurement apparatus for living body mentioned in, for example document 1. Therefore, the following description refers in detail to the control unit 17, the processing means 19, the input/output unit 20, and the image generation unit 21.

**[0024]** The following is a description of structure and operation of an optical measurement apparatus used for speech-dominant hemisphere identification, in which light having various absorptances to oxygenated hemoglobin and deoxygenated hemoglobin is transmitted from the skin surface of the head of an object to be examined to the brain while activating the speech area of the brain of the object, and relative variations of oxygenated hemoglobin concentration, relative variations of deoxygenated hemoglobin concentration, and relative variations of total hemoglobin concentration are measured from transillumination detected on the skin surface of the head, wherein the optical measurement apparatus has twenty-four measuring channels, or measuring positions. However, it is obvious that the stimulation given to the object may be replaced to visual stimulation, pain stimulation, and kinetic stimulation, according to the content of diagnosis. Further, the region to be measured in the present invention is not limited to the head, and it may be other portion and may be also applied to the living body other than the human body. Also, by increasing the number of light-transmitting positions and light-detecting positions, the number of measuring channels can be increased, whereby areas to be measured can be expanded.

**[0025]** Referring to Fig. 1, the light source unit 1 is constituted of the semiconductor laser devices 2 and the light modules 3. The semiconductor laser devices 2 is designed to transmit light having plural wavelengths between the visible area and the infrared area, for example the light having two wavelengths of 780nm and 830nm, the number of lasers corresponding to the number of the measuring positions. Here, the light having wavelengths of 780nm and 830nm is selected because light absorptance to oxygenated hemoglobin and that to deoxygenated hemoglobin are different. When the number of measuring positions is twenty-four as mentioned above, eight units of semiconductor laser devices for transmitting light of 780nm and eight units of semiconductor laser devices for transmitting the light of 830nm are provided, wherein the total number of semiconductor laser devices is sixteen. To each of light modules 3, the light having two wavelengths is to be input. Each of the light modules is provided with an oscillator having various oscillation frequencies, and modulates and outputs the light transmitted by the semiconductor laser devices 2. For example, when the light having two wavelengths is used as described above, light having modulation frequency of two wavelengths of  $780\text{nm} + \Delta f_n$  and  $830\text{nm} + \Delta f_n$ , the value of  $\Delta f_n$  being varied, is output to each light module. Thus,

the number of light modules is eight, being half of the semiconductor laser devices. Further, each of light modules is provided with an optical fiber coupler (not shown), for guiding light made by modulating the light having two wavelengths of 780nm and 830nm to one optical fiber (a light-transmitting optical fiber 8).

**[0026]** Incidentally, the values of two wavelengths of the light transmitted from the semiconductor laser devices are not limited to 780nm and 830nm, and wavelength number is also not limited to two. As a radiation source of the light, a light-emitting diode may be employed, instead of the semiconductor laser devices. As the modulation performed in the light module, analog modulation by sine wave and digital modulation by square wave with various time intervals may be employed.

**[0027]** The light made by mixing two-wavelength light emitted from the light source unit 1 is transmitted to the head to be examined of the object 9 from the tips of eight light-transmitting optical fibers 8 connected to the light modules 2 respectively. Each of four light-transmitting optical fibers 8 is fixed to the head of the object 9 by a fixing member (not shown). By putting the optical fibers through this fixing member, the positions of the optical fibers 8 are set at positions different from each other on the head of the object 9. Furthermore, in this embodiment, the tips of the light-transmitting optical fibers 8 and the detecting optical fibers 10 are alternately arranged on a tetragonal lattice. In the above-described structure, the positional relation between the light-transmitting optical fibers 8 and the detecting optical fibers 10, and modulation frequencies of the light entering the light-transmitting optical fibers 8 are recognized by the control unit 17. Incidentally, a measurement probe is described in detail in document 1.

**[0028]** The living-body transillumination which has been transmitted from the eight optical fibers 8 and has passed through the head is collected at ten detecting optical fibers 10 fixed on the fixing member. Here, the light transmitted mainly from adjacent light-transmitting optical fibers to the object 9 enters each detecting optical fiber.

**[0029]** The light entering the detecting optical fibers is detected at the photodiodes 11, which are the light detectors and are connected to the other end of each optical fiber 10. It is preferable to employ known avalanche photodiodes by which optical measurement can be performed with high sensitivity. However, if a light detector other than the photodiode is desired, something else having photoelectric conversion function, such as a photo multiplier, may be employed.

**[0030]** The living-body transillumination guided to the photodiodes 11 is converted into electric signals (living-body transillumination intensity signals), and a modulating signal corresponding to the light-transmitting point and wavelength are selectively detected at a detection circuit which can selectively detect the modulating signal, such as the lock-in amplifier module 12 consisting of a plurality of lock-in amplifiers. Here, the modulating signal

output from the lock-in amplifier module 12 is the signal which has been divided into a living-body transillumination intensity signal of particular wavelength and light-transmitting positions. However, since measurement in this embodiment is performed at twenty-four measuring points using light having two wavelengths, the number of signals to be measured is forty-eight. Therefore, the lock-in amplifier module 12 according to this embodiment is provided with a total of forty-eight lock-in amplifiers (not shown). Further, when the digital modulation is employed, a digital filter or a digital signal processor is used for the modulating signal detection.

**[0031]** The living-body transillumination intensity signals output as analog signals from the lock-in amplifier module 12 are respectively converted into digital signals by the A/D converter (analog-digital converter) 16 having forty-eight channels. Each of these signals is the living-body transillumination intensity signal corresponding to each wavelength and light-transmitting point. The above measurement is controlled by the control unit 17.

**[0032]** The living-body transillumination intensity signals converted into digital signals are sequentially output to the storing means 18 and the processing means 19. The storing means 18 sequentially stores the living-body transillumination intensity signals input above.

**[0033]** The processing means 19 calculates relative variations of oxygenated hemoglobin concentration  $\Delta C_{oxy}$  and relative variations of deoxygenated hemoglobin concentration  $\Delta C_{deoxy}$  at each measuring point from living-body transillumination intensity signals measured during the period in which word stimulation is applied, that is, a loading period with respect to standard transillumination intensity signals, being living-body transillumination intensity signals measured during a period referred to as a rest period in which word stimulation is not applied, among the above-input living-body transillumination intensity signals, and displays as a living-body transillumination intensity image on a display screen of the input/output unit 20 the relative variations of oxygenated and deoxygenated hemoglobin concentration  $\Delta C_{oxy}$  and  $\Delta C_{deoxy}$  and the relative variations of the total hemoglobin concentration, which is the sum of the relative variations of oxygenated hemoglobin concentration  $\Delta C_{oxy}$  and the relative variations of deoxygenated hemoglobin concentration  $\Delta C_{deoxy}$ . The relative variations of oxygenated hemoglobin concentration  $\Delta C_{oxy}$ , the relative variations of deoxygenated hemoglobin concentration  $\Delta C_{deoxy}$ , and the relative variations of total hemoglobin concentration being the sum of the relative variations of oxygenated hemoglobin concentration  $\Delta C_{oxy}$  and the relative variations of deoxygenated hemoglobin concentration  $\Delta C_{deoxy}$  are displayed separately or in combination. Since the calculation method of the relative variations of oxygenated hemoglobin concentration and the relative variations of deoxygenated hemoglobin concentration from the living-body transillumination intensity signals at each detection position is mentioned in document 1, the

detailed description thereof is omitted.

**[0034]** On the other hand, if graph representation of living-body transillumination intensity signals at each measuring position is commanded from a console (not shown) which is connected to the input/output unit 20, the processing means 19 according to this embodiment displays at a position corresponding to each measuring position a graph of variations of living-body transillumination intensity signals equivalent to the relative variations of oxygenated hemoglobin concentration or deoxygenated hemoglobin concentration, or the total hemoglobin concentration, instead of displaying these relative variations. Here, if representation of correlation between the living-body transillumination intensity signals at each measuring position is commanded from the console, the processing means 19 calculates a correlation value from the living-body transillumination signals at each measuring position and the predetermined standard values stored in the storing means 28, and displays a numerical value or a graph of thus obtained correlation value. This allows an examiner to objectively determine the location of every kind of function area, which has been conventionally determined by the examiner's subjective reading of the display.

**[0035]** Fig.2 is a flow chart illustrating the process of optical measurement in the optical measurement apparatus for living-body according to this embodiment. Hereinafter, operation in graph representation and measuring area setting are described with reference to Fig.2. However, as mentioned above, the flow chart shown in Fig. 2 is suitable for so-called speech-dominant-hemisphere identification diagnosis, in which the brain area which is dominant in speech function is identified in the right brain and in the left brain, when the object to be measured is a human body (the object 9).

**[0036]** First, the light-transmitting optical fibers 8 and detecting optical fibers 10 are arranged by the examiner, such that an area referred to as a speech area, which is clinically known, is within the measuring area (step 201).

**[0037]** Here, as shown in Fig.3 and Fig.4, eight light-transmitting optical fibers 8 and ten detecting optical fibers 10 are put on the head of object 9, such that first to twelfth measuring positions are set on the left brain of object 9, and thirteenth to twenty-fourth measuring points are set on the right brain. That is, four light-transmitting optical fibers t1 to t4 and five detecting optical fibers r1 to r5 are put on the left-brain side, and four light-transmitting optical fibers t5 to t8 and five detecting optical fibers r6 to r10 are put on the right-brain side. When the light-transmitting optical fibers and the detecting optical fibers are thus put on the object 9, twelve points of d1 to d12, which are intermediate positions between the light-transmitting optical fibers and the detecting optical fibers, are the measuring positions on the right-brain side, and twelve points of intermediate positions d13 to d24 are similarly measuring positions on the left-brain side.

**[0038]** After setting the optical fibers as described above, the object 9 is kept in bed, and the preliminary

measurement is performed. A standard value for calculating relative variations of oxygenated hemoglobin concentration, deoxygenated hemoglobin concentration, and the total hemoglobin concentration in the actual measurement is here measured.

**[0039]** After the preliminary measurement is completed, the actual measurement is started. The actual measurement is the combination of measurement in the rest period and measurement in the loading period. In the actual measurement according to this embodiment, a task consisting of the measurement in the rest period, the subsequent measurement in the loading period, and the measurement in the rest period subsequent to the loading period is repeatedly and continuously performed plural times (step 202).

**[0040]** When light is transmitted from the light-transmitting optical fibers 8 to the object 9, living-body transillumination which has passed through the object 9 and is modified according to the presence or absence of verbal stimulation enters one end of the detecting optical fibers 10. The living-body transillumination is sent to the apparatus body by detecting optical fibers 10, and is converted into electric signals at the photodiodes 11. After that, the living-body transillumination intensity signals are input to the lock-in amplifier modules 12 and are divided there into living-body transillumination intensity signals of each wavelength, converted into digital signals at the A/D converter 16, stored to the storing means 18, and output to the processing means 109.

**[0041]** Adding means in the processing means 19 first adds the living-body transillumination intensity signals which are input from the A/D converter 16 or read out from the storing means 18 as many times as the task number determined in advance based on the time of the start of loading or the end of loading in the same manner as, for example, when calculating the relative variations of hemoglobin concentration. Next, adding means averages the added living-body transillumination intensity signals, whereby the level of noise caused by measurement is reduced. Thus obtained living-body transillumination intensity signals (average values) are compared with the standard values and relative variations with respect to the standard values are calculated, and the relative variations are output to the display device of the input/output unit 20 in accordance with the instruction from the control unit 17. The outputs are made into graphs representing relative variations of hemoglobin concentration in twenty-four channels corresponding to the 1-24 measuring positions as shown in Fig.5, and the graphs are displayed on a screen of the display device such that the positional relation between the measuring positions can be understood by the examiner (step 203).

**[0042]** Further, only a graph selected in advance from the graphs of living-body transillumination intensity signals can be displayed on the screen of the display device connected to the input/output unit 20, whereby visibility of the graphs on the display screen may be improved. Incidentally, representations of 1ch-24ch shown in Fig.4

respectively correspond to the channel numbers showing the measuring positions in Fig.3. In this embodiment, the control unit 17 is designed to be able to control ON/OFF of display of the channel numbers through input operation from the console (not shown). Thus, the graph of each measuring points may be easily identified.

**[0043]** Further, the processing means 19 sets the relative display positions of the graphs corresponding to the measuring positions set on the object 9 according to the positional information of the measuring positions output from the control unit 17, whereby the examiner can viscerally understand the positional relation between the measuring positions and the graphs. A select button for identifiably displaying the graphs for one function area (the speech area in this embodiment) is provided on the console. By controlling the select button appropriately, the work of the examiner in referring to the displayed graphs and in selecting the graphs belonging to the same function area can be reduced.

**[0044]** In the process of selecting one function area, taking as an example the case where the measuring positions d1-d6 are set as the same function area, the left Broca's area, the examiner first selects graphs of the measuring positions d1-d6 as represented on the display. Next, selecting-operation is done by selecting an ROI icon 405 (cf. Fig.5) so as to set the areas selected by the examiner as the same function area. Thus, the living-body transillumination intensity signals at the measuring positions d1-d6 are set as the living-body transillumination intensity signals of the same function area. The selecting operation at this time is such that, for example, the examiner inputs an instruction using a pointing device or the like (not shown) connected to the input/output unit 20, and graph selecting means integrated in the processing means 19 sequentially selects graphs to be set as the same function area. Following the graph selecting operation, the examiner selects the ROI icon 405 on the screen, and the measuring areas corresponding to the selected graphs are registered as the same function area. As the measuring positions selected to be the same function area is registered, the graphs of the selected same function area are displayed with hue information on, for example, the frame of the graph, the background, the broken lines, the channel numbers or the like, so as to be discernable from graphs of other function areas.

**[0045]** Further, relative variations of hemoglobin concentration in the selected measuring areas are used as one group of data by the above selecting operation in the optical measurement apparatus for living body according to this embodiment, whereby a predetermined processing described below is enabled. Incidentally, in this embodiment, the measuring positions d1-d6 are set to be the left Broca's area, the measuring positions d7-d12 to be the left Wernicke's area, the measuring positions the d13-d18 to be the right Broca's area, and the measuring positions d19-d24 to be the right Wernicke's area.

**[0046]** After the area setting is completed, the processing means 19 averages the living-body transillumination

intensity signals in the respective measuring positions set to be the same function area, and sets the thus obtained value as the living-body transillumination intensity signal of that function area. Next, the processing means 19 generates graphs of the respective function areas from the living-body transillumination intensity signals acquired by averaging with the same process of the above graphing process of the respective measuring positions, and outputs thus obtained graphs to the input/output unit 20. Thus, as shown in Fig.6, averaged hemoglobin graphs 501-504 of the respective same function areas are displayed on the screen (step 204).

**[0047]** Next, the processing means 19 calculates correlation values between the averaged hemoglobin graphs 501-504 and a preset or examiner-set standard graph (hereinafter referred to as a correlation graph), and thus obtained correlation values are displayed in display areas 601-604 below the averaged hemoglobin graphs 501-504 (step 205).

**[0048]** The state of display at this point is shown in Fig. 6. As is clear from Fig.6, the optical measurement apparatus for living body according to this embodiment enables easy determination of similarity between the averaged hemoglobin graphs 501-504 obtained in the step 204 and the preset correlation graph. Therefore, when a standard graph of the speech area which dominantly changes in accordance with verbal stimulation is set as the correlation graph, the examiner can easily and objectively identify the speech area by comparing the correlation values displayed in the vicinity of the graphs 501-504. Although the period in which a correlation value is obtained is set as the entire period for one task in this embodiment, the embodiment is not limited thereto. For example, the correlation values of the loading period only may be calculated. Further, in this embodiment predetermined graphs or examiner-set graphs are the standard graphs for correlation calculations, but the embodiment is not limited thereto. For example, the living-body transillumination intensity signals of the respective measuring areas shown in Fig.5 may be set as the standard graphs. The structure for setting the living-body transillumination intensity signals of the respective measuring areas as the standard graphs is such that an icon for selecting standard graphs is provided on the display screen as the above-mentioned ROI icon 405 is provided, and selected graphs of living-body transillumination intensity signals are set as the standard graphs by operating this icon. In this manner, the examiner can easily select the standard graphs.

**[0049]** The processing means 19 has a function of calculating the difference between the signals in the loading period and in the rest period in the same manner as calculation of the living-body transillumination intensity signals at the respective measuring positions, after dividing the living-body transillumination intensity signals calculated in the step 204 by the living-body transillumination intensity signals in the period of applying verbal stimulation (loading period) and by the living-body transillumi-

nation intensity signals in the rest period (rest). The difference values obtained by this difference calculation function are displayed under the respective averaged hemoglobin graphs 501-504 (step 206).

5 **[0050]** Fig.8 shows the state of display at this point. As is clear from Fig.8, numerical values of relative variations of the same function areas are displayed in display areas 701-704, whereby the area which dominantly changes in response to verbal stimulation can be objectively identified. As a result, efficiency of speech dominant-hemisphere identification diagnosis done by the examiner may be improved. Incidentally, the difference values calculated in this step may be the relative variations of the total hemoglobin concentration, which is used when generating the living-body transillumination intensity image. The above-described series of operations in the processing means 19 is executed by software installed in the control unit 17.

10 **[0051]** Fig.9 is a diagram showing the setting process of the correlation graph in the optical measurement apparatus for living body according to this embodiment. Hereinafter, the setting process of the correlation graph in the optical measurement apparatus for living body according to this embodiment is described with reference to Fig.9.

15 **[0052]** As shown in Fig.9, in this embodiment, nine variation points 804 are provided in order to form a correlation graph 801 during the loading period and the rest periods which are set before and after the loading period. On the setting screen of the correlation graph 801 shown in Fig.9, the processing means 19 performs spline interpolation processing between the respective variation points 804 to form the correlation graph 801 after the examiner sets positions (the signal-intensity direction and the time-axis direction) of the respective variation points 804. Here, the positions of the respective variation points 804 on the time axis and the signal intensity axis are displayed in a chart 803 on the same screen so as to allow the examiner to set the correlation graph 801. Especially, when the coordinate values in the chart 803 showing coordinate positions of the respective variation points 804 are modified, this modification is promptly reflected to the correlation graph 801 in this embodiment, whereby the setting of the correlation graph 801 can be easily and effectively performed. Further, bars 802 indicating a starting point and an ending point of the loading period are provided within the display area of the correlation graph 801. By using the bars 802 as indication lines for setting the correlation graph 801, the examiner can set the correlation graph more easily. Incidentally, the interpolation processing by the processing means 19 need not be the spline interpolation, but the interpolation processing due to other interpolation calculations, such as linear interpolation, may be employed. The number of variation points 804 is not limited to nine.

20 **[0053]** Further, in this embodiment, an area in which a formula for setting the form of correlation graph 801 (a formula input area) is provided on the same screen,

wherein the correlation graph can be set according to the formula which is directly input by the examiner. Here, the formula to be set is displayed in the formula display area 805. The above-described correlation processing is also executed by the software installed in the control unit 17. [0054] According to the above-described embodiment, the input/output unit 20 generates a graph in accordance with average values output from the processing means 19, the graph is displayed on the display device connected to the input/output unit 20, and the difference values corresponding to the respective graphs are displayed in the vicinity of the respective graphs by the input/output unit 20, whereby the examiner can objectively understand the variations of the transillumination. Therefore, the speech area can be objectively determined (step 207).

[0055] Further, correlation values of the function areas more suitable for diagnosis are calculated by calculating correlations with respect to the standard values stored in storing means 18, and the examiner can perform diagnosis with reference to the result thereof so that diagnostic efficiency is improved.

[0056] The above is the detailed description of the present invention according to the embodiment of the present invention. However, the invention is not limited to this embodiment. Various changes may be made without departing from the scope of the invention.

[0057] The following is a brief description of the effects brought by the representative elements of the invention laid open in this application:

- (1) Since the examiner can objectively understand variations of transillumination, he or she can objectively determine the speech area to be examined;
- (2) Since the examiner can observe intensity variations of transillumination within measurement areas determined by the arrangement of a plurality of light-transmitting and detecting optical fibers placed on the object, he or she can objectively understand the variations of the transillumination in a particular function area, and can perform determination on the function area to be examined. Therefore, diagnostic efficiency is improved.
- (3) The examiner can easily understand the result of comparison between variations of transillumination intensity in each measurement area or/and each group and variations of transillumination intensity from the standard graph, whereby diagnostic efficiency is further improved.

## Claims

1. An optical measurement apparatus for a living body comprising:

light transmitting means (1) for transmitting light to a plurality of positions in an area being exam-

ined within a living body;  
light detecting means (11) for detecting light which has been transmitted by said light transmitting means and has passed through the living body at a plurality of positions in the area being examined;

load applying means for applying to the living body a load to which the living body responds;  
means (12, 17) for calculating signals representing intensity change of the transillumination detected by said light detecting means at measuring points determined based on positional relation between said light transmitting means and said light detecting means, during a period in which the load is applied to the living body and periods in which the load is not applied;

means (19) for calculating time variations of at least one signal among two signals calculated above at said measuring points;

means (19) for converting the time variations of light signal at each measuring point into time variations of hemoglobin concentration;

display control means (19, 20) for displaying graphs of the above calculated time variations of hemoglobin concentration in correspondence with positional relation between each of said light transmitting means and said light detecting means;

means (19, 405) for selecting and classifying graphs displayed by said display control means on display means so as to create groups (401-404) of graphs; and means (19) for averaging measured values of signals of a respective group created by said selecting means, and means for displaying on said display means the average data (501-504) of the respective group averaged by said averaging means.

2. An apparatus according to claim 1, further comprising means (405) for displaying each group of graphs classified by said selecting means so as to be distinguishable from other groups of graphs.
3. An apparatus according to claim 1, comprising means for displaying only one particular group among the plurality of groups selected and classified by said selecting means.
4. An apparatus according to claim 1, wherein said averaging means (19) includes means for converting the calculated average values into data of graphs to be displayed on said display means.
5. An apparatus according to claim 4, comprising means (19) for calculating a correlation between standard data representing characteristics of one group selected above and the data calculated by said averaging means, and means for displaying values

(601-604) representing the calculated correlation in the vicinity of the displayed graphs.

6. An apparatus according to claim 5, comprising means (18) for storing the standard data representing characteristics of one group selected above, and means for reading out the stored standard data. 5
7. An apparatus according to claim 5, comprising means (20) for inputting the standard data representing characteristics of one group selected above. 10
8. An apparatus according to claim 7, wherein said standard data input means includes an operation device for inputting on a screen of said display means a plurality of coordinate points on a coordinate system having two axes indicating signal intensity and time, means for calculating by interpolation processing the coordinate points located in a plane between the respective coordinate points input by this operation device, and means for generating a correlation standard graph from the input coordinate points and the coordinate points calculated by the interpolation processing 20
9. An apparatus according to claim 8, wherein said standard data input means includes means for converting signal intensity and time of the coordinate points input by said operation device into numerical values, and displaying the numerical values in the form of a chart. 25
10. An apparatus according to claim 4, comprising means for calculating a difference value between an average value of measured values in the period in which the load is applied to the living body and an average value of measured values in the period in which the load is not applied to the living body, and means for displaying the difference value calculated by this difference value calculating means in the vicinity of each graph displayed above. 30
11. An apparatus according to claim 1, wherein: 35

said light transmitting means comprises a plurality of light-transmitters to be discretely arranged on the head of a living body for transmitting light; 45

said light detecting means comprises a plurality of light detectors to be discretely arranged on the head of the living body alternately with said light transmitting means, for detecting light which has been transmitted by said light-transmitters and has passed through the living body; through the living body; 50

said load applying means is adapted for applying stimulation to which the living body responds when applied; and 55

said calculating means (12, 17, 19) comprise:

preliminary measurement means for performing preliminary measurement in a state where a load is not applied to the living body so as to measure a standard signal; actual measurement means for performing actual measurement having rest periods in which a load is not applied to the living body and a loading period in which a load is applied to the living body by said load applying means, and measuring signals representing an intensity change of the transillumination detected by said light detecting means; and means for calculating relative variations of the measured signals in the actual measurement with respect to the standard signal by comparing the above-calculated signals and the standard signal.

12. An apparatus according to claim 11, wherein said light light-transmitters and said light detectors are adapted to be arranged corresponding to brain function areas of the living body. 25
13. An apparatus according to claim 11, wherein said preliminary measurement means is adapted to repeatedly measure signals a plural number of times with a predetermined period in a state where the living body is kept in bed, to calculate the average value thereof, and to store this average value in storing means as a standard value. 30
14. An apparatus according to claim 11, wherein said actual measurement means is adapted to sequentially execute measurement in the rest period and measurement in the loading period a plural number of times, to average measured signals at each measuring period along elapsed time, and to store thus calculated average values as measured values. 35
15. An apparatus according to claim 1, wherein: 40

said converting means (19) is adapted for converting time variations of intensity of the transillumination detected by said light detecting means (11) when brain functions of the living body are activated into time variations of hemoglobin concentration, and generating graph data of the time variations of hemoglobin concentration. 45

## 55 Patentansprüche

1. Optische Meßvorrichtung für einen lebenden Körper, aufweisend:

- eine Lichtaussendeeinrichtung (1) zum Aussenden von Licht an mehrere Orte in einem zu untersuchenden Bereich innerhalb eines lebenden Körpers,  
eine Lichterfassungseinrichtung (11) zum Erfassen von Licht, das von der Lichtaussendeeinrichtung ausgesandt wurde und an mehreren Orten in dem zu untersuchenden Bereich durch den lebenden Körper hindurchgetreten ist,  
eine Belastungseinrichtung zum Anlegen einer Last an den lebenden Körper, auf die dieser reagiert,  
eine Einrichtung (12, 17) zum Berechnen von Signalen, die eine Intensitätsänderung der Durchleuchtung darstellen, die von der Lichterfassungseinrichtung an Meßpunkten, die aufgrund einer Ortsbeziehung zwischen der Lichtaussendeeinrichtung und der Lichterfassungseinrichtung bestimmt sind, während einer Zeitspanne, in der die Last an den lebenden Körper angelegt wird, und Zeitspannen, in denen die Last nicht angelegt wird, erfaßt wird,  
eine Einrichtung (19) zum Berechnen zeitlicher Änderungen mindestens eines von zwei wie oben an den Meßpunkten berechneten Signalen,  
eine Einrichtung (19) zum Umwandeln der zeitlichen Änderungen des Lichtsignals an jedem Meßpunkt in zeitliche Änderungen der Haemoglobinkonzentration,  
eine Anzeigesteuereinrichtung (19, 20) zum Anzeigen von Graphen der wie oben berechneten zeitlichen Änderungen der Haemoglobinkonzentration entsprechend der Ortsbeziehung zwischen der jeweiligen Lichtaussendeeinrichtung und Lichterfassungseinrichtung,  
eine Einrichtung (19, 405) zum Auswählen und Klassifizieren von Graphen, die von der Anzeigesteuereinrichtung auf einer Anzeigeeinrichtung angezeigt werden, um Gruppen (401 bis 404) von Graphen zu bilden, und  
eine Einrichtung (19) zum Mitteln von Meßwerten von Signalen einer entsprechenden von der Auswahleinrichtung gebildeten Gruppe und eine Einrichtung zum Anzeigen der gemittelten Daten (501 bis 504) der entsprechenden Gruppe, die von der Mittelungseinrichtung gemittelt wurden, auf der Anzeigeeinrichtung.
2. Vorrichtung nach Anspruch 1 mit einer Einrichtung (405) zum Anzeigen einer jeweiligen Gruppe von Graphen, die von der Auswahleinrichtung klassifiziert wurden, so daß sie von anderen Gruppen von Graphen unterscheidbar ist.
3. Vorrichtung nach Anspruch 1 mit einer Einrichtung zum Anzeigen lediglich einer bestimmten Gruppe unter den von der Auswahleinrichtung ausgewählten
- und klassifizierten Gruppen.
4. Vorrichtung nach Anspruch 1, wobei die Mittelungseinrichtung (19) eine Einrichtung zum Umwandeln der berechneten Mittelwerte in Daten von Graphen zur Anzeige auf der Anzeigeeinrichtung aufweist.
5. Vorrichtung nach Anspruch 4 mit einer Einrichtung (19) zum Berechnen einer Korrelation zwischen Standarddaten, die Charakteristiken einer wie oben ausgewählten Gruppe darstellen, und den von der Mittelungseinrichtung berechneten Daten und einer Einrichtung zum Anzeigen von Werten (601 bis 604), die die berechnete Korrelation darstellen, in der Gegend der angezeigten Graphen.
6. Vorrichtung nach Anspruch 5 mit einer Einrichtung (18) zum Speichern der Standarddaten, die Charakteristiken einer wie oben ausgewählten Gruppe darstellen, und einer Einrichtung zum Auslesen der gespeicherten Standarddaten.
7. Vorrichtung nach Anspruch 5 mit einer Einrichtung (20) zum Eingeben der Standarddaten, die Charakteristiken einer wie oben ausgewählten Gruppe darstellen.
8. Vorrichtung nach Anspruch 7, wobei die Standarddaten-Eingabeeinrichtung eine Bedienungsvorrichtung, um auf einem Schirm der Anzeigeeinrichtung mehrere Koordinatenpunkte auf einem Koordinatensystem mit zwei Achsen, die die Signalintensität und die Zeit angeben, einzugeben, eine Einrichtung zum Berechnen der Koordinatenpunkte, die in einer Ebene zwischen den entsprechenden von der Bedienungsvorrichtung eingegebenen Koordinatenpunkten liegen, durch Interpolation und eine Einrichtung zum Erzeugen eines Korrelations-Standardgraphen aus den eingegebenen Koordinatenpunkten und den durch Interpolation berechneten Koordinatenpunkten aufweist.
9. Vorrichtung nach Anspruch 8, wobei die Standarddaten-Eingabeeinrichtung eine Einrichtung zum Umwandeln der Signalintensität und Zeit der von der Bedienungsvorrichtung eingegebenen Koordinatenpunkte in numerische Werte und zum Anzeigen der numerischen Werte in Form einer Kurve aufweist.
10. Vorrichtung nach Anspruch 4 mit einer Einrichtung zum Berechnen des Differenzwerts zwischen einem Mittelwert gemessener Werte in der Zeitspanne, in der die Last an den lebenden Körper angelegt wird, und einem Mittelwert gemessener Werte in der Zeitspanne, in der die Last nicht an den lebenden Körper angelegt wird, und einer Einrichtung zum Anzeigen des von der Differenz-Berechnungseinrichtung be-

rechneten Differenzwerts in der Gegend jedes wie oben angezeigten Graphen.

11. Vorrichtung nach Anspruch 1, wobei die Lichtaussendeeinrichtung mehrere Lichtabstrahler aufweist, die auf dem Kopf eines lebenden Körpers an diskreten Stellen anzuordnen sind, um Licht abzustrahlen, die Lichtfassungseinrichtung mehrere Lichtdetektoren aufweist, die auf dem Kopf des lebenden Körpers an diskreten Stellen abwechselnd zur Lichtaussendeeinrichtung anzuordnen sind, um Licht zu erfassen, das von den Lichtabstrahlern abgestrahlt wurde und durch den lebenden Körper hindurchgetreten ist, die Belastungseinrichtung eingerichtet ist, eine Stimulation anzulegen, auf deren Anlegen der lebende Körper reagiert, und die Berechnungseinrichtung (12, 17, 19) folgendes umfaßt:
- eine Vorrichtung zum Durchführen einer Vormessung in einem Zustand, in dem die Last nicht an den lebenden Körper angelegt ist, um ein Standardsignal zu messen,
- eine eigentliche Meßeinrichtung zum Durchführen einer eigentlichen Messung mit Ruhezeitspannen, in denen keine Last an den lebenden Körper angelegt wird, und einer Belastungszeitspanne, in der von der Belastungseinrichtung eine Last an den lebenden Körper angelegt wird, und zum Messen von Signalen, die eine Intensitätsänderung des von der Lichtfassungseinrichtung erfaßten Durchleuchtens darstellen, und
- eine Einrichtung zum Berechnen relativer Veränderungen der gemessenen Signale durch Vergleichen der wie oben berechneten Signale und des Standardsignals.
12. Vorrichtung nach Anspruch 11, wobei die Lichtabstrahler und die Lichtdetektoren in Entsprechung zu hirnfunktionalen Bereichen des lebenden Körpers angeordnet sind.
13. Vorrichtung nach Anspruch 11, wobei die Vorrichtung eingerichtet ist, Signale mehrfach wiederholt mit einer vorbestimmten Zeitspanne in einem Zustand zu messen, in dem sich der lebende Körper im Bett befindet, den Mittelwert daraus zu berechnen und diesen Mittelwert als Standardwert in einer Speichereinrichtung zu speichern.
14. Vorrichtung nach Anspruch 11, wobei die eigentliche Meßeinrichtung eingerichtet ist, gemessene Signale an jedem Meßpunkt entlang dem Zeitablauf zu mitteln und die so berechneten Mittelwerte als Meßwerte zu speichern.

15. Vorrichtung nach Anspruch 1, wobei die Umwandlungseinrichtung (19) eingerichtet ist, zeitliche Veränderungen der Intensität der Durchleuchtung, die von der Lichtfassungseinrichtung (11) bei Aktivierung von Hirnfunktionen des lebenden Körpers erfaßt werden, in zeitliche Änderungen der Haemoglobinkonzentration umzuwandeln und Graphdaten der zeitlichen Änderungen der Haemoglobinkonzentration zu erzeugen.

### Revendications

1. Appareil de mesure optique pour corps vivant comprenant :
- un moyen émettant de la lumière (1) pour transmettre de la lumière à une pluralité de positions dans une zone d'examen d'un corps vivant ;
- un moyen détectant la lumière (11) pour détecter la lumière qui a été émise par ledit moyen émettant de la lumière et qui a traversé le corps vivant en une pluralité de positions dans la zone d'examen ;
- un moyen appliquant une charge pour appliquer au corps vivant une charge à laquelle le corps vivant répond ;
- un moyen (12, 17) pour calculer des signaux représentant un changement d'intensité de la transillumination détectée par ledit moyen détectant la lumière en des points de mesure déterminés d'après la relation de position entre ledit moyen émettant de la lumière et ledit moyen détectant la lumière, au cours d'une période pendant laquelle la charge est appliquée au corps vivant et de périodes pendant lesquelles la charge n'est pas appliquée ;
- un moyen (19) pour calculer les variations temporelles d'au moins un signal parmi deux signaux calculés précédemment auxdits points de mesure ;
- un moyen (19) pour convertir les variations temporelles d'un signal de lumière à chaque point de mesure en des variations temporelles de la concentration en hémoglobine ;
- un moyen de commande d'affichage (19, 20) pour afficher des courbes des variations temporelles de la concentration en hémoglobine calculées ci-dessus en correspondance avec la position de relation entre chacun desdits moyen émettant de la lumière et moyen détectant la lumière ;
- un moyen (19, 405) pour sélectionner et classer les courbes affichées par ledit moyen de commande d'affichage sur un moyen d'affichage afin de créer des groupes (401-404) de courbes ; et
- un moyen (19) pour faire la moyenne des va-

- leurs mesurées de signaux d'un groupe respectif créé par ledit moyen de sélection, et un moyen pour afficher sur ledit moyen d'affichage les données moyennes (501-504) du groupe respectif dont la moyenne a été calculée par ledit moyen de moyenne. 5
2. Appareil selon la revendication 1, comprenant en outre un moyen (405) pour afficher chaque groupe de courbes classé par ledit moyen de sélection de façon à ce qu'il puisse être distingué des autres groupes de courbes. 10
3. Appareil selon la revendication 1, comprenant un moyen pour afficher seulement un groupe particulier parmi la pluralité de groupes sélectionnés et classés par ledit moyen de sélection. 15
4. Appareil selon la revendication 1, dans lequel ledit moyen de moyenne (19) comprend un moyen pour convertir les valeurs moyennes calculées en données de courbes à afficher sur ledit moyen d'affichage. 20
5. Appareil selon la revendication 4, comprenant un moyen (19) pour calculer une corrélation entre des données standard représentant les caractéristiques d'un groupe sélectionné ci-dessus et les données calculées par ledit moyen de moyenne, et un moyen pour afficher des valeurs (601-604) représentant la corrélation calculée au voisinage des courbes affichées. 25  
30
6. Appareil selon la revendication 5, comprenant un moyen (18) pour mémoriser les données standard représentant les caractéristiques d'un groupe sélectionné ci-dessus, et un moyen pour lire les données standard mémorisées. 35
7. Appareil selon la revendication 5, comprenant un moyen (20) pour saisir les données standard représentant les caractéristiques d'un groupe sélectionné ci-dessus. 40
8. Appareil selon la revendication 7, dans lequel ledit moyen de saisie de données standard comprend un dispositif d'opération pour saisir sur un écran dudit moyen d'affichage une pluralité de points de coordonnées sur un système de coordonnées ayant deux axes indiquant l'intensité d'un signal et le temps, un moyen pour calculer par un traitement par interpolation les points de coordonnées situés dans un plan entre les points de coordonnées respectifs saisis par le dispositif d'opération, et un moyen pour générer une courbe standard de corrélation à partir des points de coordonnées saisis et des points de coordonnées calculés par le traitement d'interpolation. 45  
50  
55
9. Appareil selon la revendication 8, dans lequel ledit moyen de saisie de données standard comprend un moyen pour convertir l'intensité de signal et le temps des points de coordonnées saisis par le dispositif d'opération en valeurs numériques, et afficher les valeurs numériques sous la forme d'un tableau. 5
10. Appareil selon la revendication 4, comprenant un moyen pour calculer une valeur de différence entre une valeur moyenne de valeurs mesurées dans la période pendant laquelle la charge est appliquée au corps vivant et une valeur moyenne de valeurs mesurées dans la période pendant laquelle la charge n'est pas appliquée au corps vivant, et un moyen pour afficher la valeur de différence calculée par ce moyen de calcul de valeur de différence au voisinage de chaque courbe affichée ci-dessus.
11. Appareil selon la revendication 1, dans lequel :  
20  
25  
30  
35  
40  
45  
50  
55
- ledit moyen émettant de la lumière comprend une pluralité d'émetteurs de lumière à placer de façon discrète sur la tête d'un corps vivant pour émettre de la lumière ;  
ledit moyen détectant la lumière comprend une pluralité de détecteurs de lumière à placer de façon discrète sur la tête du corps vivant de manière alternée avec ledit moyen émettant de la lumière, pour détecter la lumière qui a été émise par lesdits émetteurs de lumière et qui a traversé le corps vivant ;  
ledit moyen appliquant une charge est adapté pour appliquer une stimulation à laquelle le corps vivant répond lorsqu'elle est appliquée ; et  
ledit moyen de calcul (12, 17, 19) comprend :
- un moyen de mesure préliminaire pour effectuer une mesure préliminaire dans un état où aucune charge n'est appliquée au corps vivant afin de mesurer un signal standard ;  
un moyen de mesure actuelle pour effectuer une mesure actuelle comportant des périodes de repos pendant lesquelles aucune charge n'est appliquée au corps vivant et une période de chargement pendant laquelle une charge est appliquée au corps vivant par ledit moyen d'application de charge, et mesurer des signaux représentant un changement d'intensité de la transillumination détectée par ledit moyen détectant la lumière ; et  
un moyen pour calculer des variations relatives des signaux mesurés dans la mesure actuelle par rapport au signal standard en comparant les signaux calculés ci-dessus et le signal standard.

12. Appareil selon la revendication 11, dans lequel lesdits émetteurs de lumière et lesdits détecteurs de lumière sont adaptés pour être disposés en correspondance avec des zones de fonctions cérébrales du corps vivant. 5
13. Appareil selon la revendication 11, dans lequel ledit moyen de mesure préliminaire est adapté pour mesurer de façon répétée des signaux plusieurs fois avec une période prédéterminée dans un état dans lequel le corps vivant est maintenu au lit, pour calculer leur valeur moyenne, et pour mémoriser cette valeur moyenne dans un moyen de stockage en tant que valeur standard. 10  
15
14. Appareil selon la revendication 11, dans lequel ledit moyen de mesure actuelle est adapté pour exécuter de façon séquentielle une mesure dans la période de repos et une mesure dans période de chargement, plusieurs fois, pour calculer la moyenne des signaux mesurés à chaque période de mesure avec le temps écoulé, et pour mémoriser les valeurs moyennes ainsi calculées en tant que valeurs mesurées. 20  
25
15. Appareil selon la revendication 1, dans lequel ledit moyen de conversion (19) est adapté pour convertir les variations temporelles d'intensité de la transillumination détectée par ledit moyen détectant la lumière (11) lorsque les fonctions cérébrales du corps vivant sont activées en des variations temporelles de la concentration en hémoglobine, et pour générer des données de courbe des variations temporelles de la concentration en hémoglobine. 30  
35

40

45

50

55

FIG.1

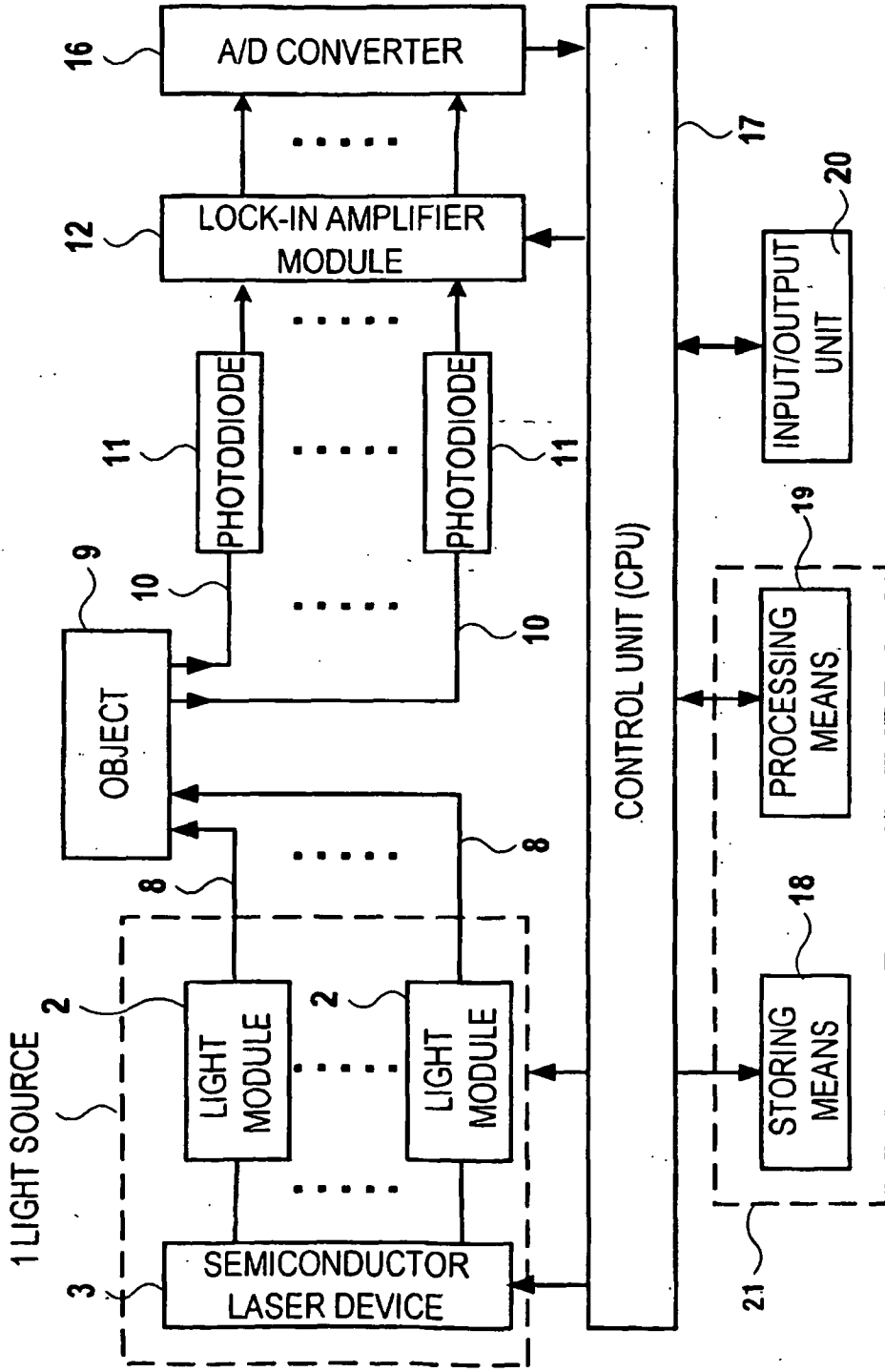

FIG.2

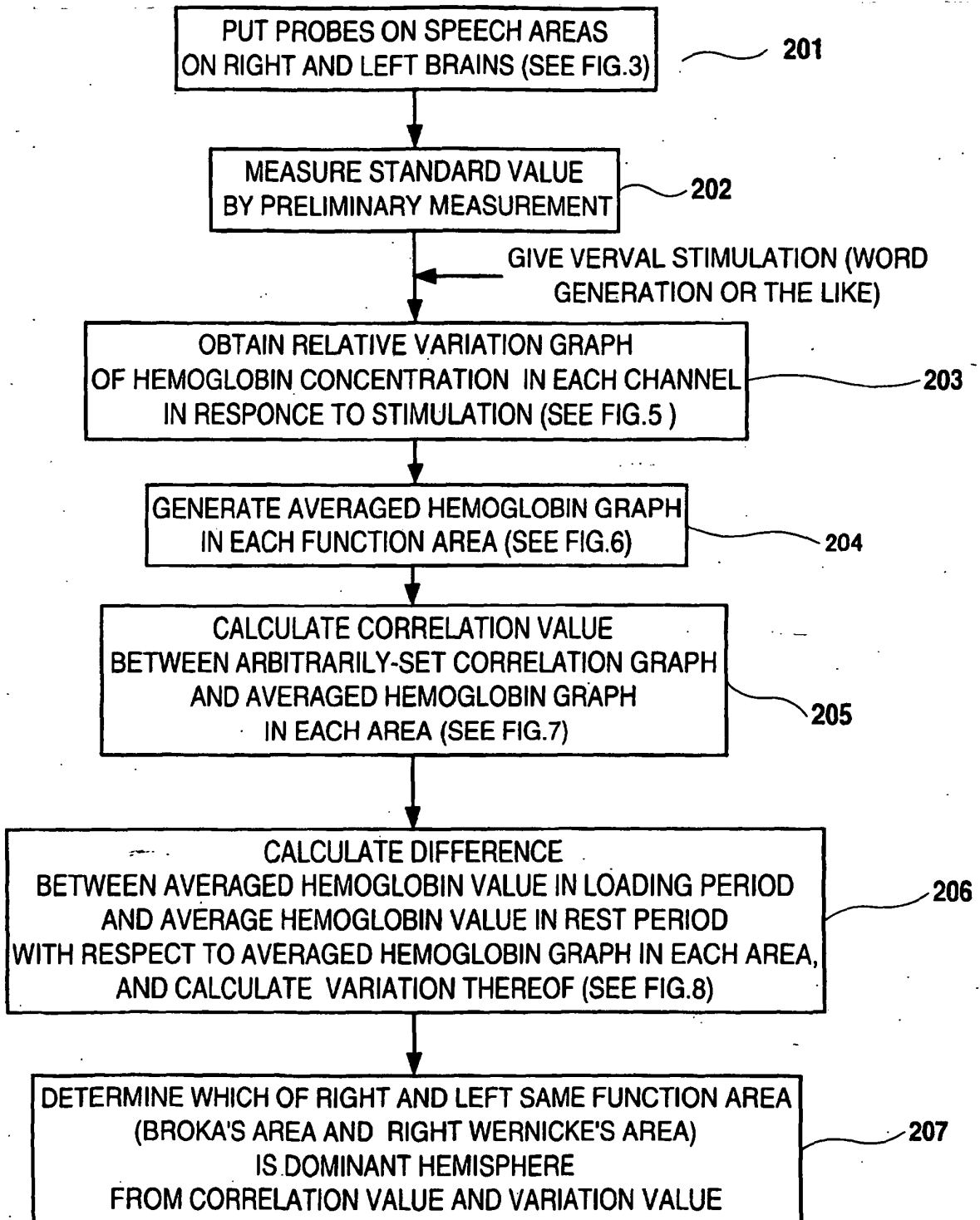

FIG.3

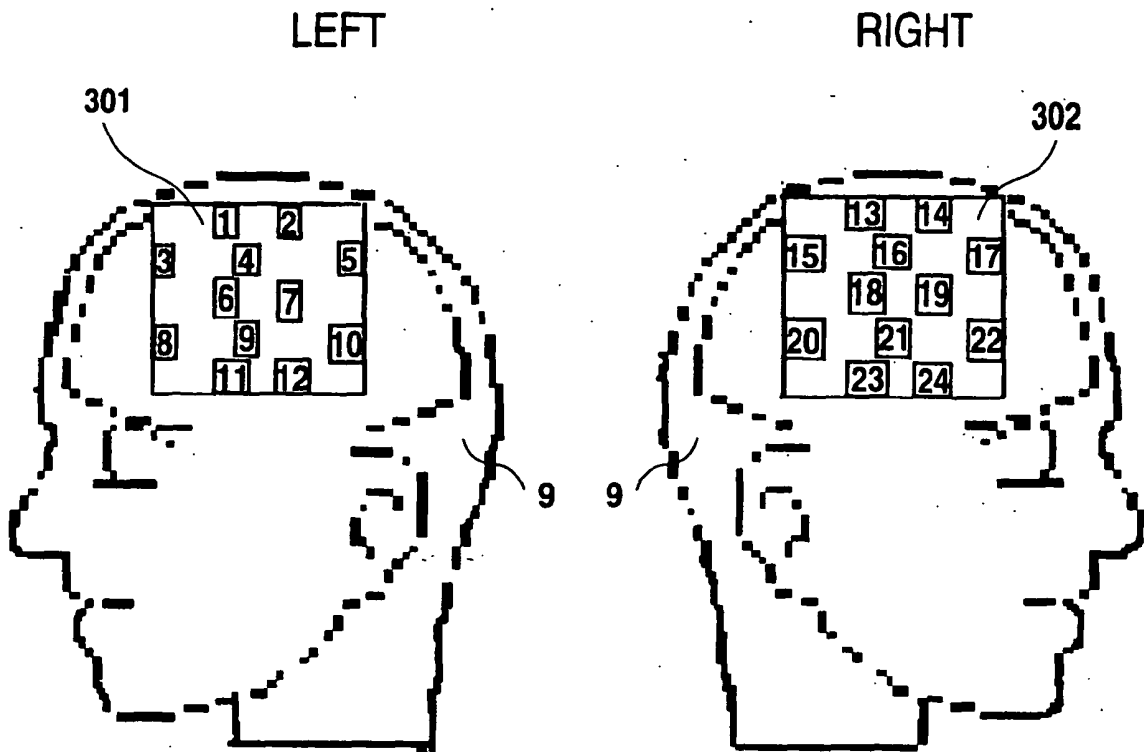

FIG.4

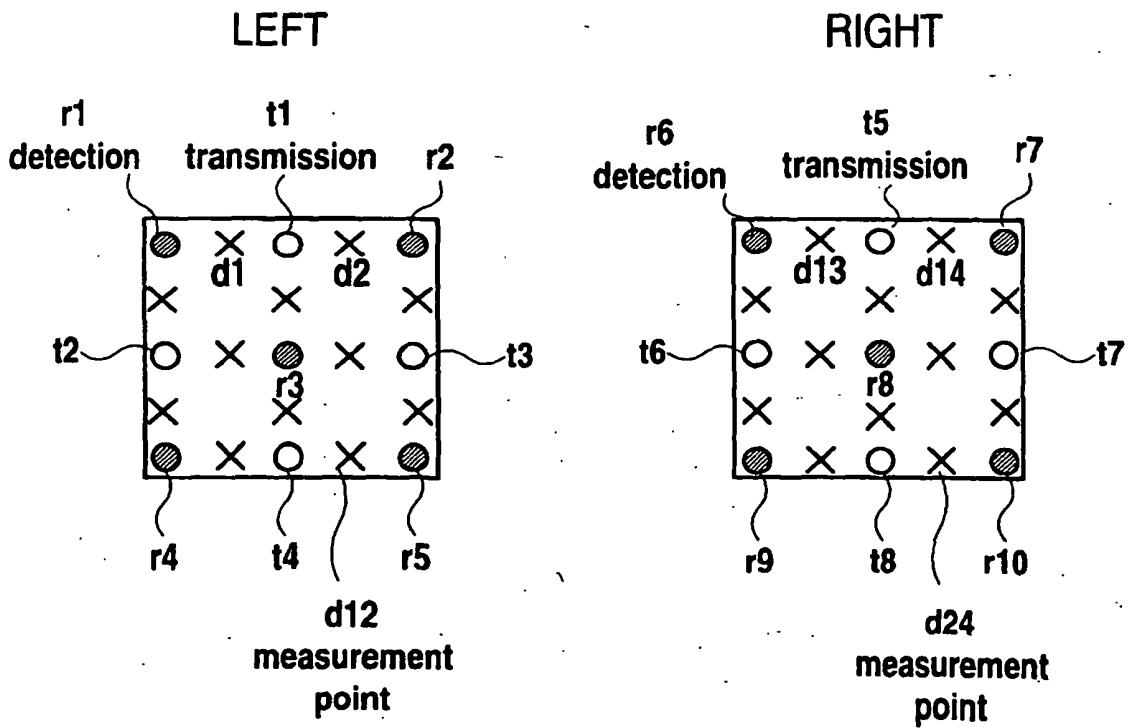

FIG.5

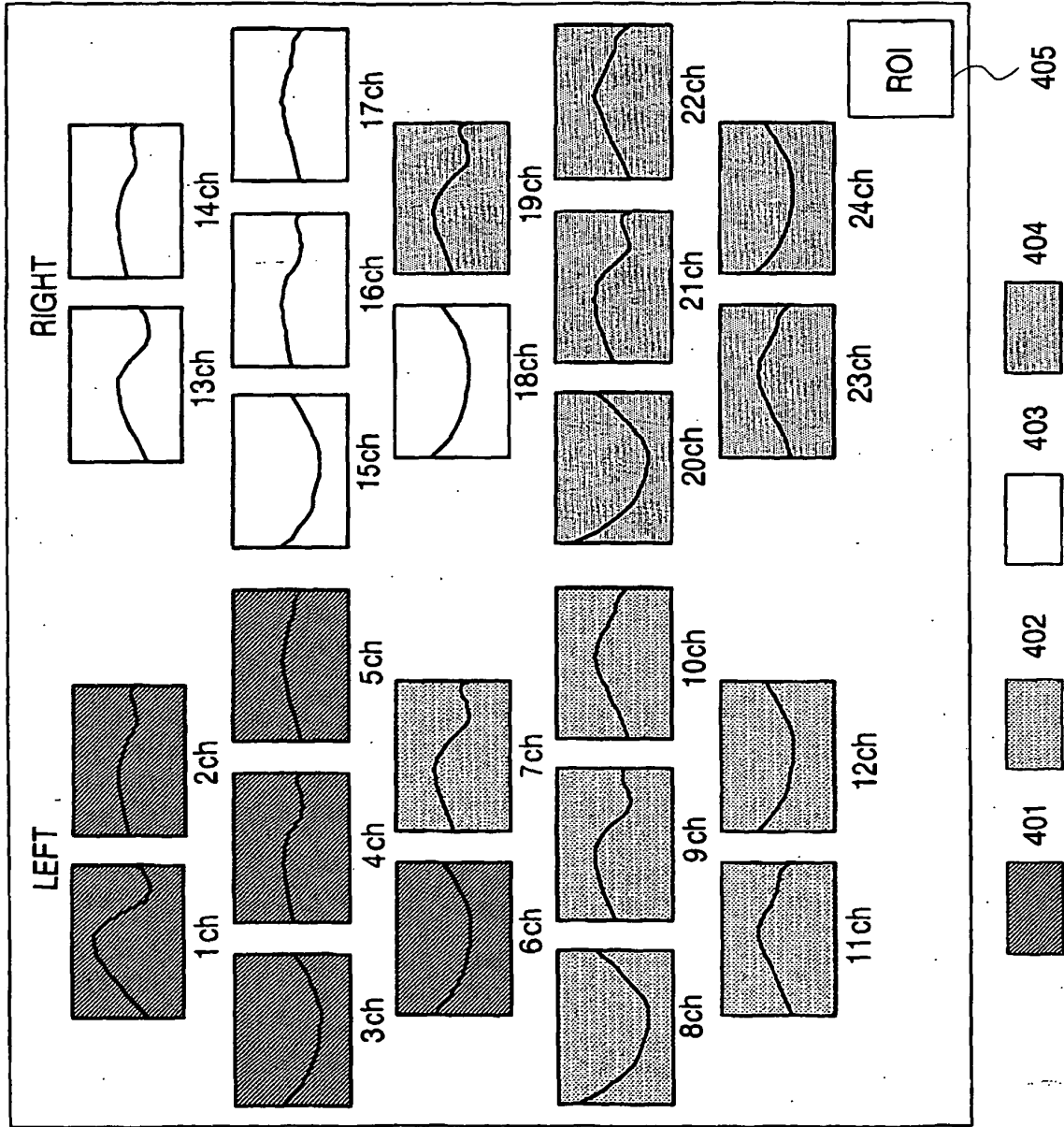

FIG.6

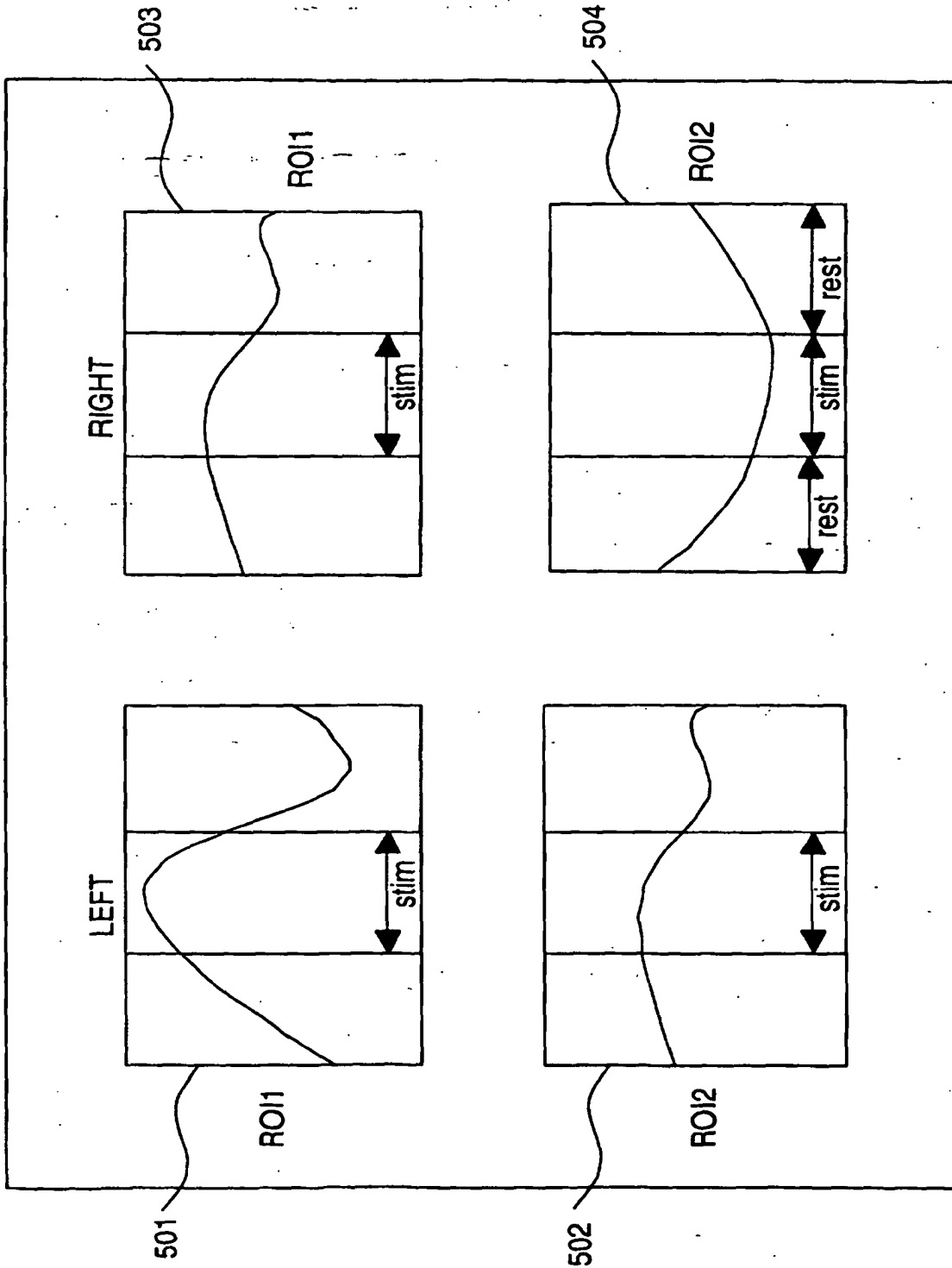

FIG.7

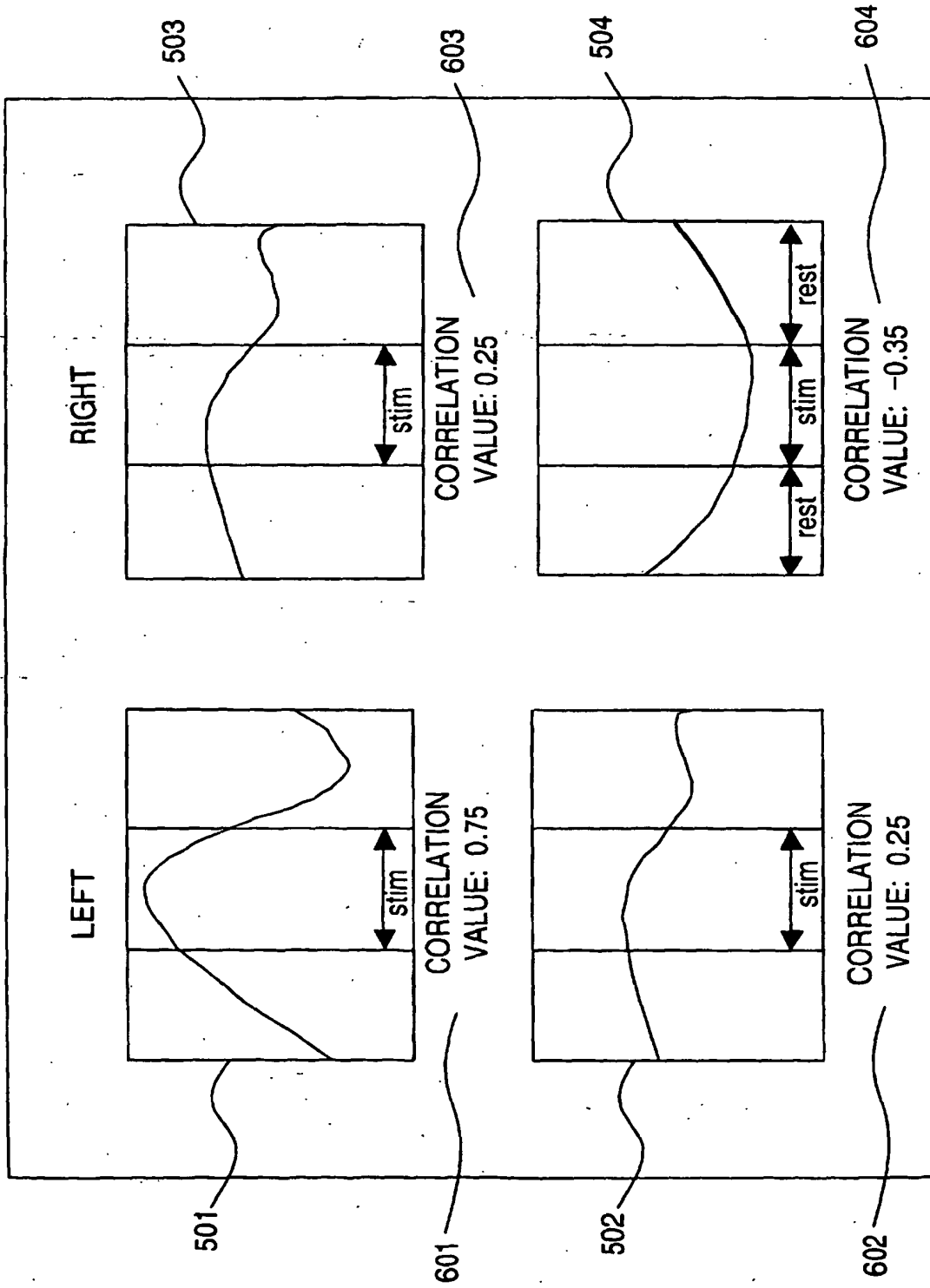

FIG. 8

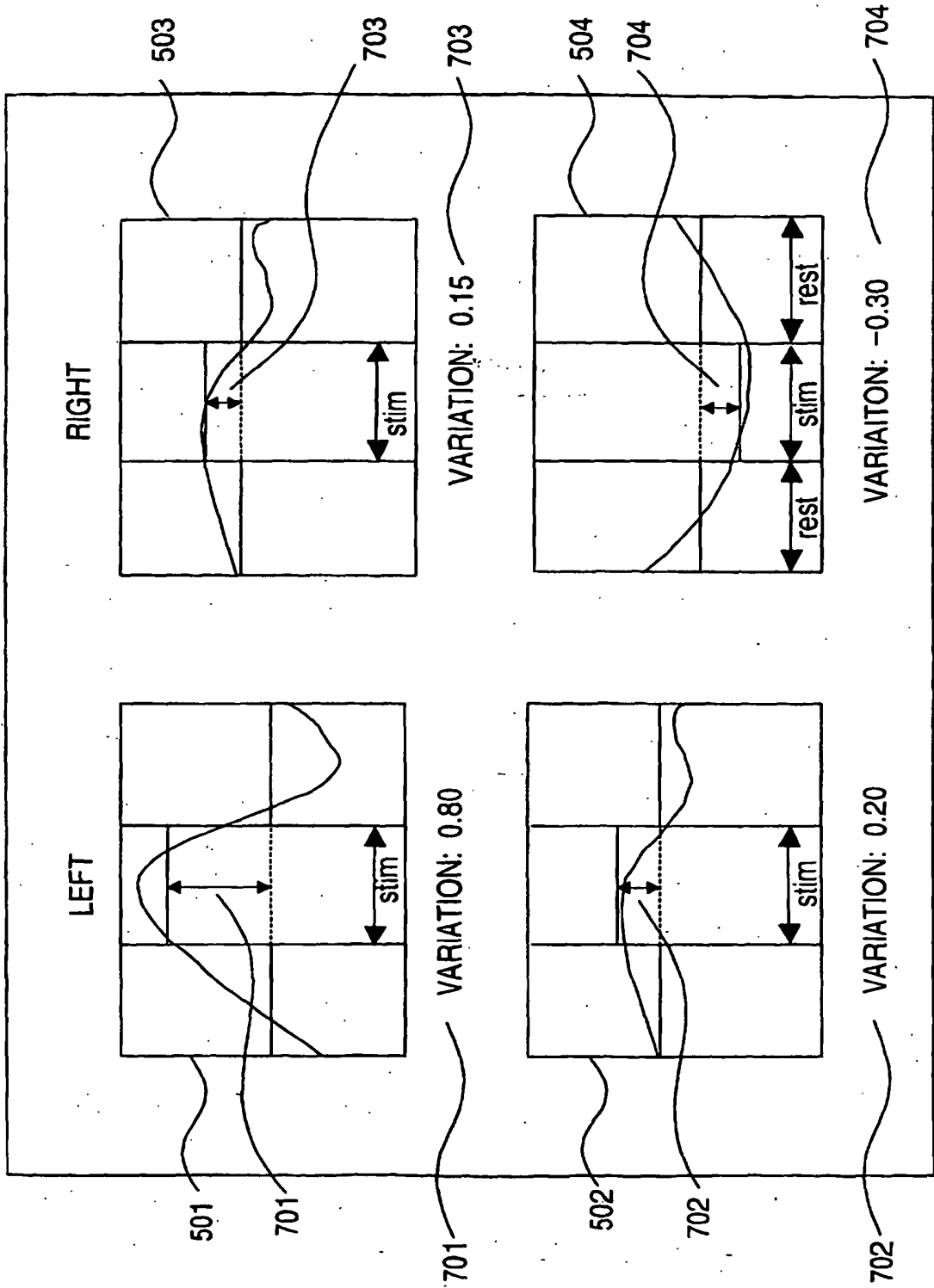
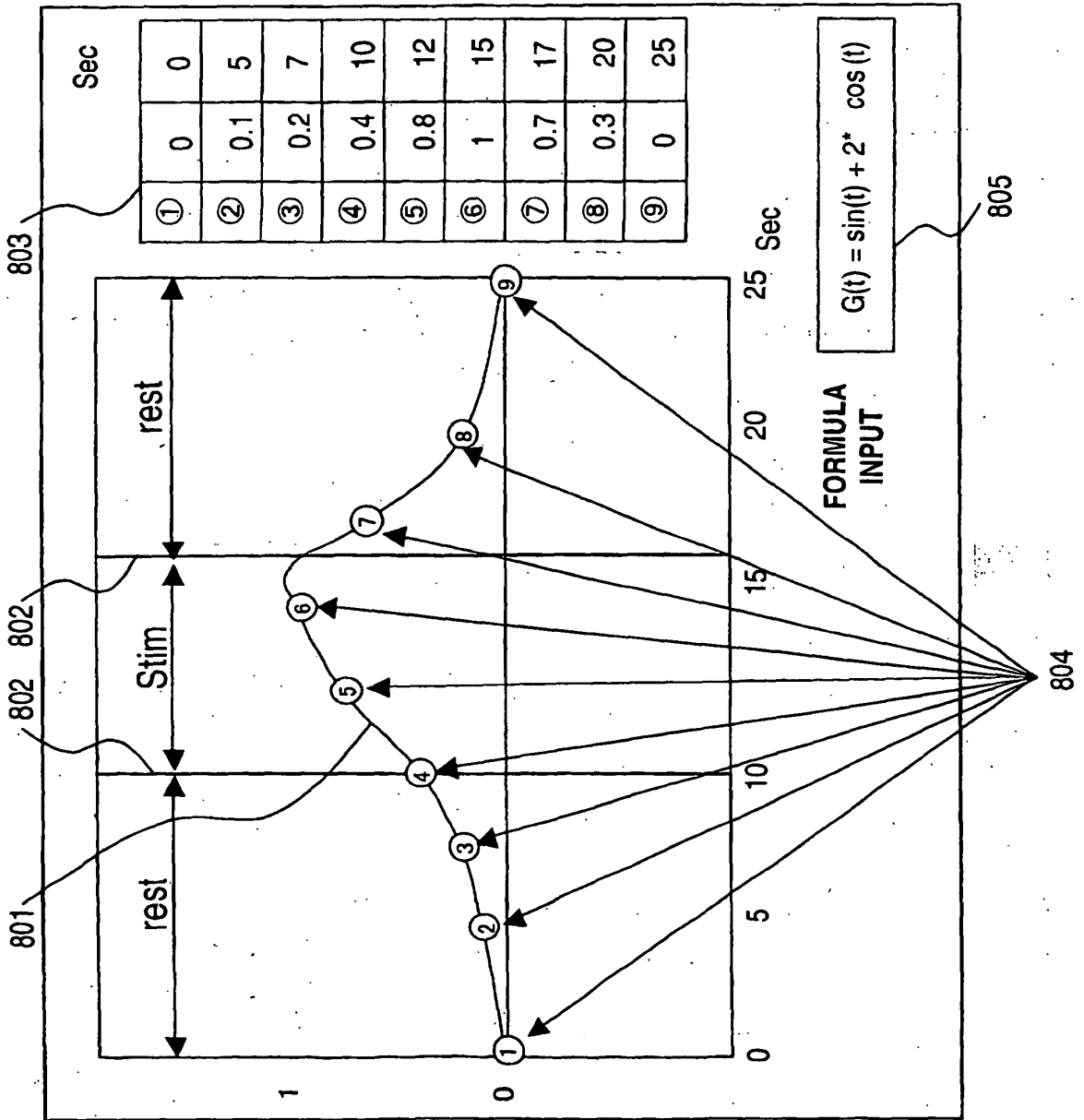

FIG.9



**REFERENCES CITED IN THE DESCRIPTION**

*This list of references cited by the applicant is for the reader's convenience only. It does not form part of the European patent document. Even though great care has been taken in compiling the references, errors or omissions cannot be excluded and the EPO disclaims all liability in this regard.*

**Patent documents cited in the description**

- JP 9098972 A [0002]

专利名称(译)	有机光学测量仪器		
公开(公告)号	<a href="#">EP1327418B1</a>	公开(公告)日	2010-05-19
申请号	EP2001974872	申请日	2001-10-16
[标]申请(专利权)人(译)	株式会社日立医药		
申请(专利权)人(译)	日立医疗器械股份有限公司		
当前申请(专利权)人(译)	日立医疗器械股份有限公司		
[标]发明人	KAWASAKI SHINGO WATANABE EIJU		
发明人	KAWASAKI, SHINGO WATANABE, EIJU		
IPC分类号	A61B10/00 A61B5/00 A61B17/00		
CPC分类号	A61B5/14553 A61B5/0048 A61B5/4094 A61B2017/00057 A61B2562/0233 A61B2562/046		
优先权	2000315115 2000-10-16 JP		
其他公开文献	EP1327418A1 EP1327418A4		
外部链接	<a href="#">Espacenet</a>		

摘要(译)

本发明公开了一种生物体光学测量装置，其具有光传输装置，用于将光传输到生物体内待检查区域的多个位置。光检测装置，用于检测由光传输装置传输并在检查区域的多个位置穿过活体的光；负荷施加装置，用于向生物体施加生物体响应的负荷；用于计算表示由光检测装置在测量点处检测到的透照强度变化的信号的装置，所述测量点是在负载施加到活体的时间段内基于每个光传输装置和光检测装置之间的位置关系确定的。以及未施加负荷的期间；用于计算上述在基于每个光发送装置和光检测装置之间的位置关系确定的测量点处计算的至少一个信号的时间变化的装置；显示控制装置，用于根据每个光发送装置和光检测装置之间的位置关系显示上述计算信号的图形。

